

# M966 TOW

## MISSILE CARRIER



### 1/35TH SCALE

### M966 험머 토우미사일형

What started out as a replacement for the famous and very familiar 4x4 utility vehicle whose name cannot be used, developed into a broad series of four wheel drive vehicles that serve the US Army in a multitude of roles. Manufactured by AM General, one of the most interesting is the M966 TOW Missile Carrier.

The M966 TOW Missile Carrier are equipped with a hardtop enclosure containing four doors, windows and rear hatch the same as the M1025 Armament Carrier, but with a 36-inch weapon ring. The launcher is attached to the ring, but supported by a floor mounted pedestal. The launcher can be removed from the vehicle and set up as a ground mounted launcher. The M966 has an internal capacity for carrying six TOW rounds. The M966 have a two-way cargo door which is used for loading missiles into the vehicle or reloading the launcher.

험머는 80년대 초까지 미군에서 사용되었던 M151 루트의 대체 차량으로 AM제너럴사에 의해 개발되었고, 1985년부터 미군에 납품되기 시작하였다. 험머의 특징은 무엇보다도 임무에 맞게 자유자재로 변형이 가능한 다용도성과 4륜 구동, 150마력의 출력을 내는 강력한 성능이다.

수많은 험머의 파생형중 하나인 M966 토우 미사일 장착형은 기본형인 M1025 무장 탑재차와 같은, 4개의 도어와 후부 햇치로 구성된 하드탑식 구조의 차체에 이루어져 있다. 단지 토우 발사기를 장착하기 위해 회전식 무장 마운트 링의 직경이 36인치로 변경된 점이 M1025와의 차이점이다. 토우 발사기는 기본적으로 무장 마운트링에 장착되고, 내측 바닥판에 고정되는 구조인데, 발사기는 마운트에서 손쉽게 제거가 가능하므로, 차내에 잠비한 삼각대에 장착하여 지면에서도 쉽게 거치하여 발사할 수 있다. M966은 차내에 총 6발의 토우 미사일을 격납할 수 있으며, 2중식 화물 도어를 통해 미사일을 재장전한다.

GRS. VEHICLE WEIGHT : 6,051 lbs. / 2,745 kg.  
 OVERALL LENGTH : 180 in. / 4.58 m.  
 OVERALL WIDTH : 85 in. / 2.16 m.  
 OVERALL HEIGHT (w/o TOW) : 72 in. / 1.83 m.  
 WHEELBASE : 130 in. / 3.29 m.  
 SPEED : 65 mph / 105 kmph  
 CRUISING RANGE : 300 mi. / 482 km.  
 MAXIMUM TOWED LOAD : 3,400 lbs. / 1,542 kg.

최대 중량 : 6,051 lbs. / 2,745 kg.  
 전장 : 180 in. / 4.58 m.  
 전폭 : 85 in. / 2.16 m.  
 전고 (TOW제외) : 72 in. / 1.83 m.  
 바퀴 축간 폭 : 130 in. / 3.29 m.  
 최고 속도 : 65 mph / 105 kmph  
 행동 반경 : 300 mi. / 482 km.  
 최대 견인 중량 : 3,400 lbs. / 1,542 kg.

■ 조립하기 전에

- 부품을 조립하기 전에 설명서를 잘 읽어본 후 조립한다.
- 부품을 지을 때에는 칼이나 니퍼로 깨끗이 잘라준다.
- 접착제를 사용할 곳과 사용하지 않는 곳에 주의하고 너무 많이 바르지 않도록 한다.
- 접착하기 전에 부품을 맞추어 확인한 후 조립한다.

- 에나멜 페인트나 접착제를 사용할 때는 창문을 열어 환기를 시키고 화기를 멀리한다.
- 사용 후 남은 부품은 어린 아이들의 손에 닿지 않도록 잘 처리한다.

1 ■ Suspension 차체 지지스프링

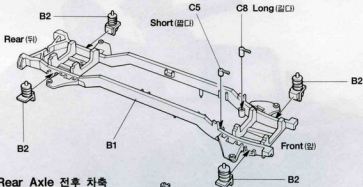

■ Front Rear Axle 전후 차축

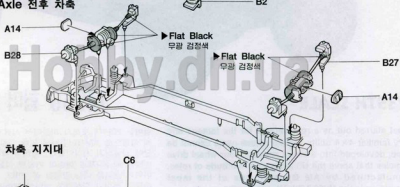

■ Axles Guide 차축 지지대

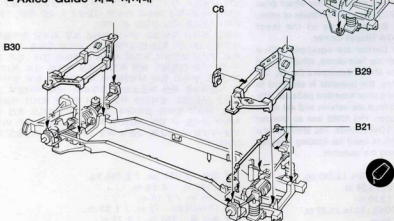

공작용 칼  
Crafts Knife  
칼  
Knife  
톱질  
Saw  
톱질  
Saw



공작용의 망치  
Crafts Hammer  
OO NOT SET  
NO USE SET  
NO USE SET  
NO USE SET  
NO USE SET  
NO USE SET  
NO USE SET



플러그  
Plug  
플러그  
Plug  
플러그  
Plug  
플러그  
Plug



오류  
Error  
오류  
Error  
오류  
Error  
오류  
Error  
오류  
Error



3  
3  
3  
3  
3  
3  
3  
3  
3  
3

이전 페이지  
Previous page  
이전 페이지  
Previous page  
이전 페이지  
Previous page  
이전 페이지  
Previous page  
이전 페이지  
Previous page

2

### ■ Engine 엔진부

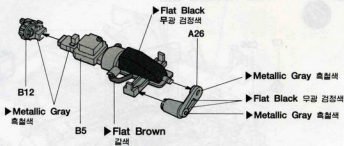

### ■ Drive Shaft 동력회전축

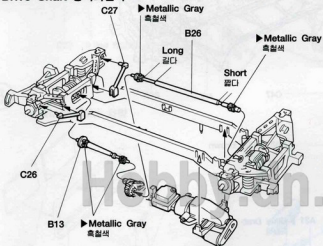

### ■ Muffler 머플러

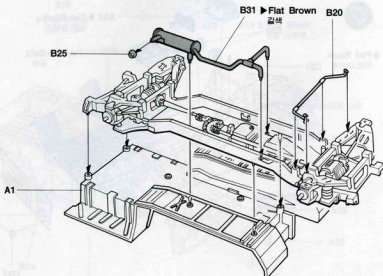

3

### ■ Fuel Tank(연료 탱크)

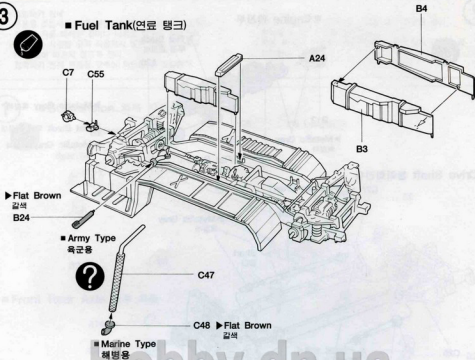

4

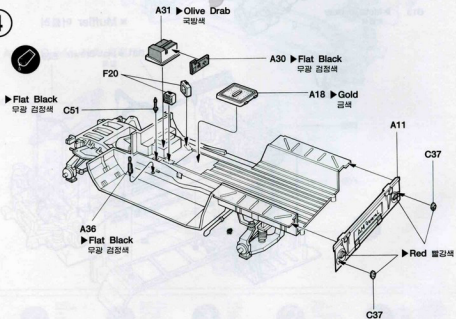

5

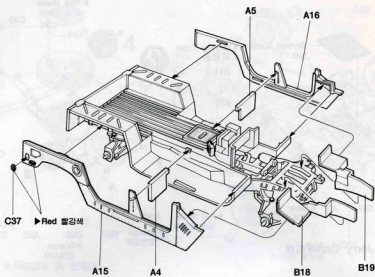

6

### ■ Windshield 차창

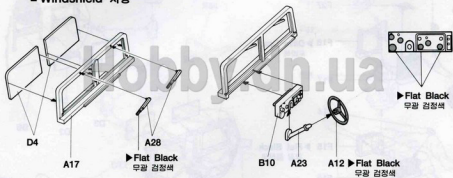

7

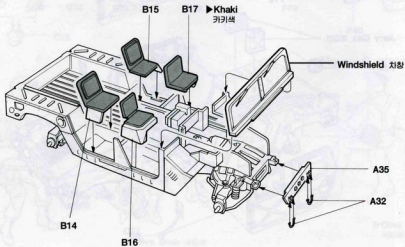

8

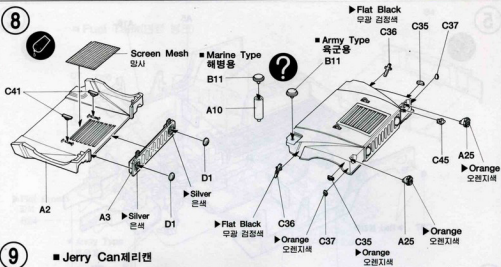

9

### Jerry Can 제리캔

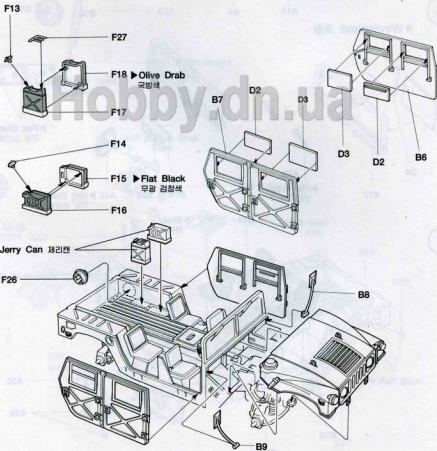

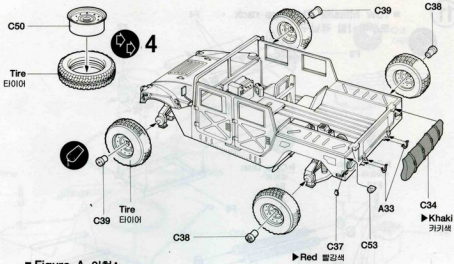

10

■ Figure A 인형A

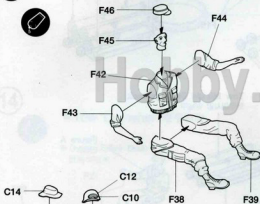

■ Figure B 인형B

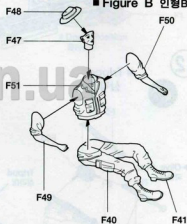

■ Figure C 인형C

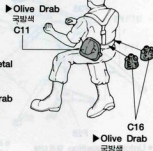
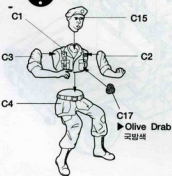

11

■ Tow Missile Storage rack  
토우미사일 격납구

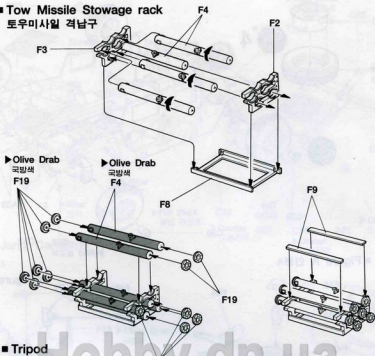

12

■ Tripod 삼각대

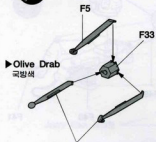

■ Folded position 접힌상태

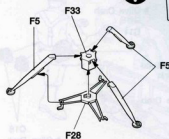

■ Unfolded position 펼친상태

※ Note the Step 15  
⑮ 참조

Tow Missile Storage rack  
토우미사일 격납구

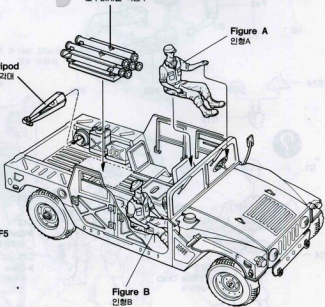
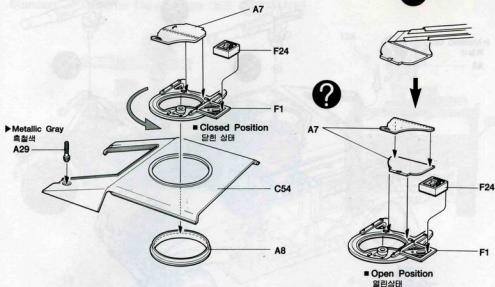

Figure A  
인형A

Figure B  
인형B



13



Hobby.dn.ua

14

■ Tow Launcher 토우런처

▶ Overall: Olive Drab  
전체: 옥망색

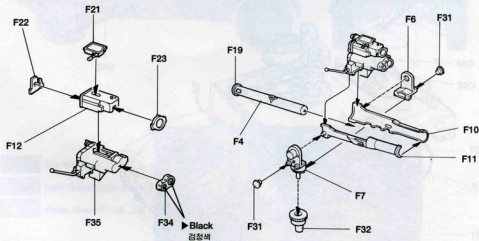

15

▶ Metallic Gray  
회색  
A6

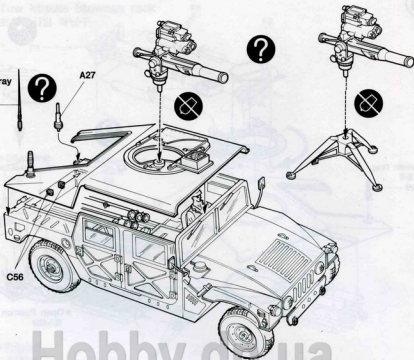

16

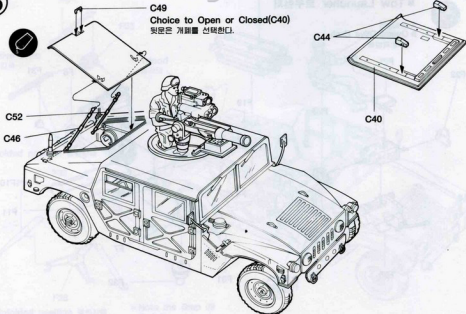

C49  
Choice to Open or Closed(C40)  
뒷문은 개폐를 선택한다.

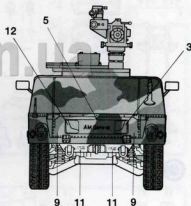
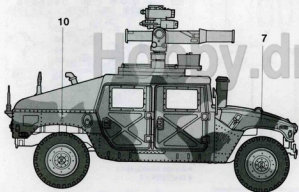
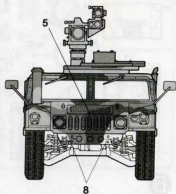
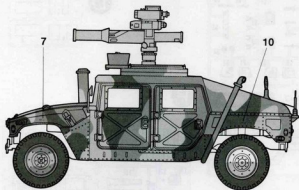

# Painting & Apply Decals 색칠 및 전사마크 붙이기

## Standard 3 Patterns Camouflage (표준 3색미채 차량)



-  Flat Black (무광 검정색)
-  Light Brown (라이트 브라운)
-  Forest Green (포리스트 그린)

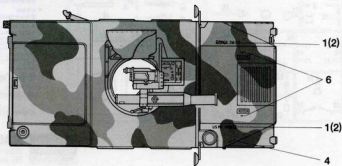

# Parts Located Diagram 부품도

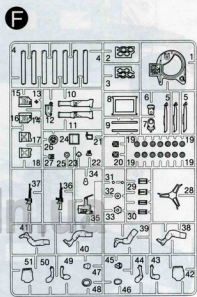
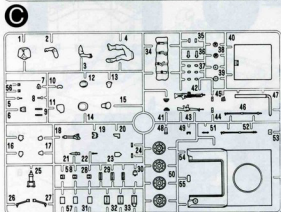
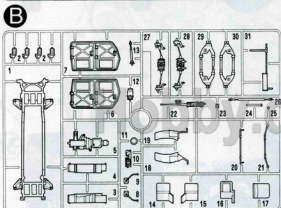
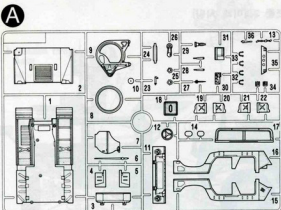

- Decal(전사지) × 1
- Screen Mesh(망사) × 1
- Tre타이어 × 4

**Unused Parts 불필요 부품**  
 A13, A19, A20, A21, A22, A34, B22, B23, C9, C18, C25, C28, C29, C30, C31, C32, C33, C42, C57, C58, F25

- 직책명 겸 A/우편번호  
 영업부 742-9299, 이물처리센터 8000-6282, 학원(주)문산학원 071-7011-4299
- A/우편번호  
 본사 808-7000(교문)147, 학원부 745-9293, 인쇄부 488-8888
- 총판명 겸 A/우편번호  
 강북아카데미 488-8884, 강북아카데미 782-0880  
 강서아카데미 311-6200, 강남아카데미 02-5596-8940  
 양주아카데미 0352744-8829, 양주아카데미 0352741-8828  
 시흥아카데미 0313810-8773, 서울아카데미 807-0840  
 아카데미(주) 02-527-8801, 강북아카데미 879-9987  
 문산아카데미 798-1254, 문산아카데미 711-8922
- 홈페이지  
<http://www.academy.co.kr>
- 고객센터 문의  
 080-969-7000
- 우 소  
 서울시 강북구 수유 2동 273-64

**ACADEMY** HOBBY MODEL KITs **ACADEMY PLASTIC MODEL CO., LTD.**  
 273-64, Suyu-dong, Kangbuk-gu, Seoul, Korea  
 TEL 82-2-908-7000 FAX 82-2-997-3003