

COURTESY U.S. BOMBERS, BY LLOYD S. JONES, AERO PUBLISHERS

**ACADEMY**

HOBBY MODEL KITS

GENERAL DYNAMICS

# F-111A

**AARDVARK**

STRATEGIC BOMBER

1/48TH SCALE

Hobby.dn.ua

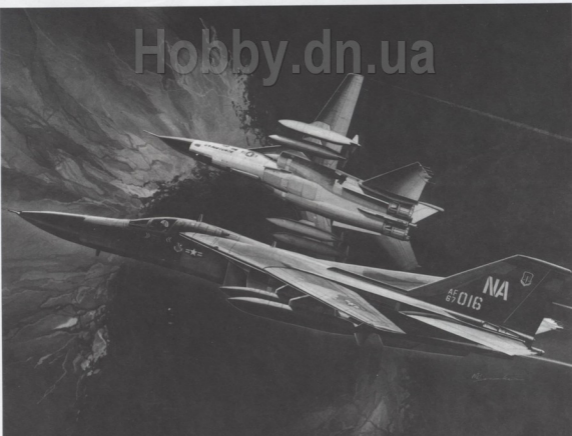



---

## THE F-111A AARDVARK

---

Designed to be a multi-service tactical strike fighter, the F-111 developed into one of the most controversial aircraft ever constructed. Its problems started with the McNamara decree that the plane be designed for use by both the Air Force and Navy. Due to weight limitations that the F-111 could never achieve, the Navy version of the F-111, after seven years of expensive development was scrapped, but the technology became part of the rapidly developed Grumman F-14 tomcat!

Once divorced from its dual service role, the Aardvark or TFX as it was called during its developmental days, became a truly fine and useful piece of hardware, but its teething problems were long and severe. More hours were spent on wind-tunnel testing, 20,000, than any other modern aircraft, but when finally accepted for operational duty, it was quickly learned that the aircraft had met or exceeded every requirement originally set forth by the Air Force.

The F-111A first saw action in Viet Nam in 1968 when its terrain-following radar was put to use. Again, teething problems and cracks in the wing box led to grounding of the aircraft, but within a year, the fixes had been made and the 250 F-111's were again put on active duty. Armed with conventional or nuclear weapons, the F-111A became known as a pilot's airplane, fiercely defended by its crews as one of the best planes flying.

Parts Locator Diagram

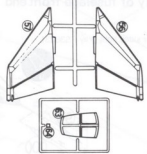
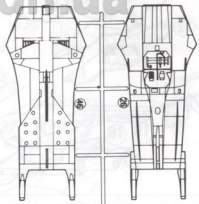
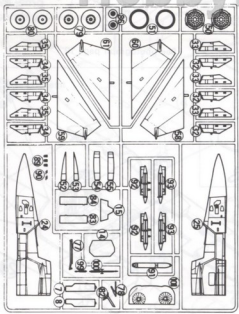
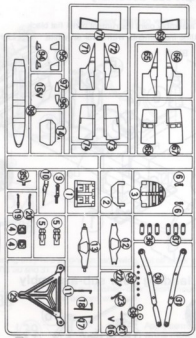
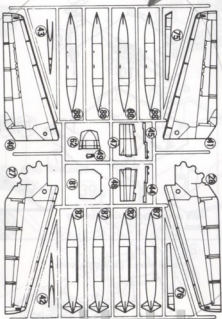



## 5 Lower half wing assembly

Engage gear teeth so wing angles are equal.

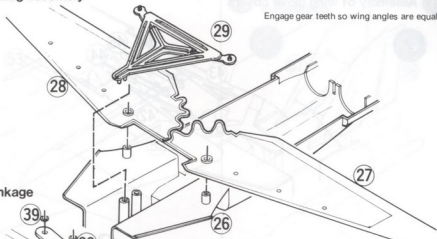

## 6 Pylon and linkage assembly

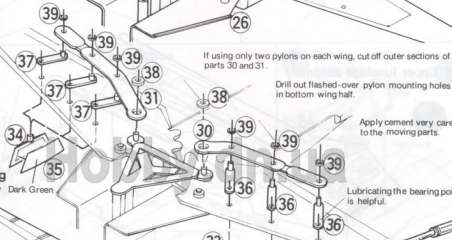

If using only two pylons on each wing, cut off outer sections of parts 30 and 31.

Drill out flashed-over pylon mounting holes in bottom wing half.

Apply cement very carefully to the moving parts.

Lubricating the bearing points is helpful.

## 7 Final wing assembly

Dark Green

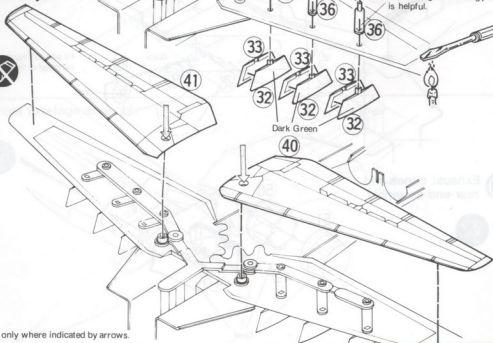

Press-fit only where indicated by arrows.

## 8 Assembly of wing glove covers

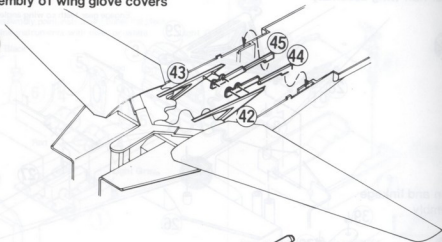

## 9 Upper fuselage assembly

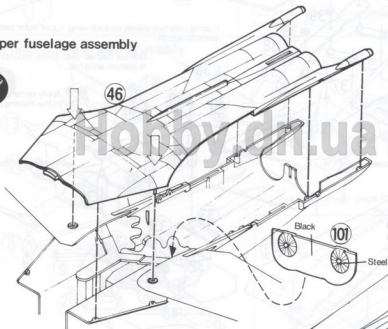

Fit part 101 tightly to point indicated or wings will bind.

Black

101

Steel

## 10 Exhaust cones and rear-end assembly

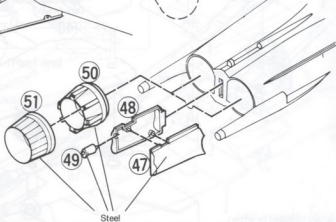

Steel

### 11 Stabilator fillet installation

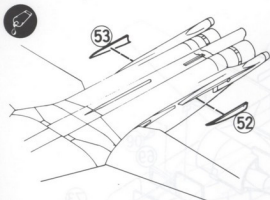

### 12 Rudder assembly and installation

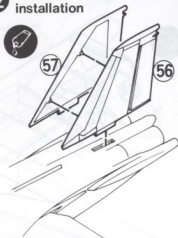

### 13 Stabilator assembly and installation

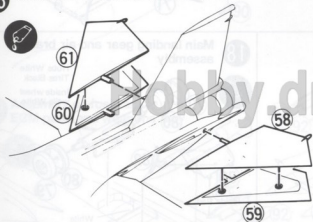

### 14 Canopy and hood assembly

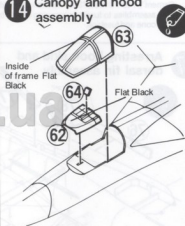

### 15 Front fuselage assembly

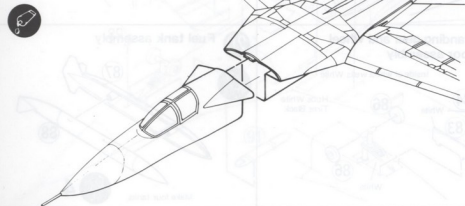

## 16 Triple-plough intake assembly

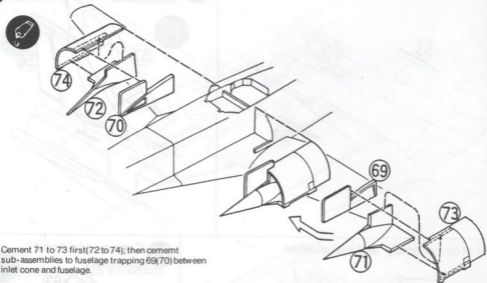

Cement 71 to 73 first(72 to 74); then cement sub-assemblies to fuselage trapping 69(70) between inlet cone and fuselage.

## 17 Arresting hook, skid and dorsal fin assembly

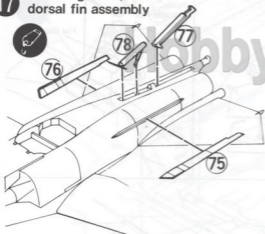

## 18 Main landing gear and air brake assembly

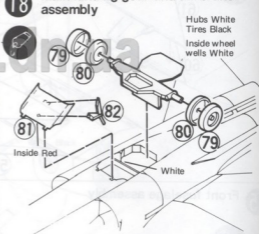

Hubs White  
Tires Black  
Inside wheel wells White

Inside Red

White

## 19 Front landing gear and wheel well door assembly



Inside of wheel wells White

Hubs White  
Tires Black

White

## 20 Fuel tank assembly



Make four tanks.

4



## 21 Antenna installation

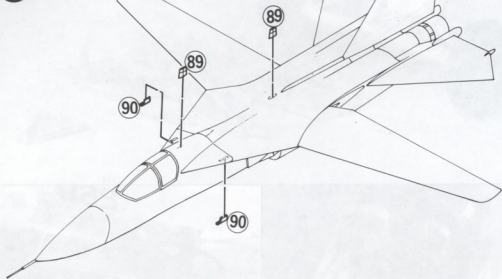

## 22 Assembly of fuel tanks, ECM pods and weapons tray

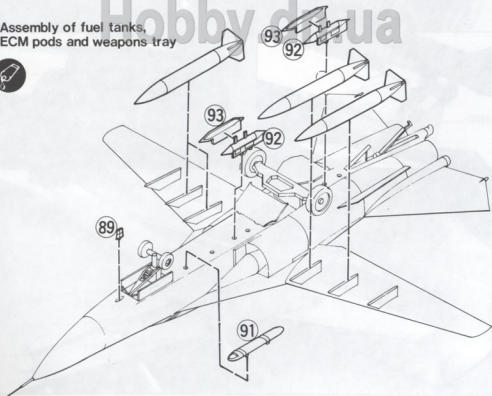

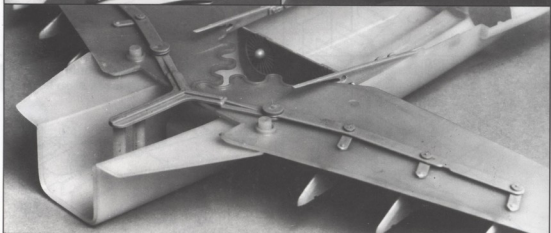
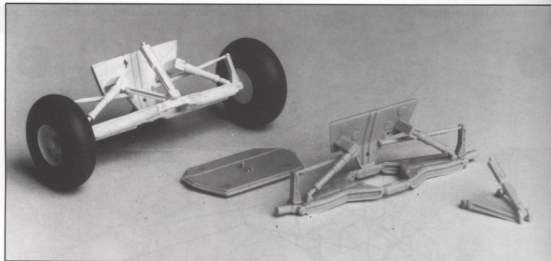

Painting and decal placement guide

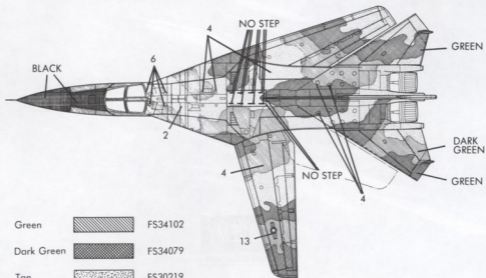
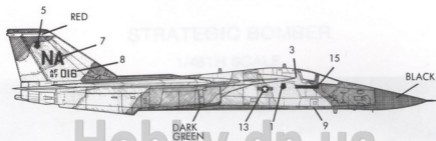
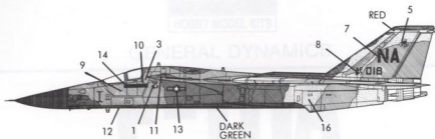

- |            |  |         |
|------------|--|---------|
| Green      |  | FS34102 |
| Dark Green |  | FS34079 |
| Tan        |  | FS30219 |
| Black      |  |         |