



SCALE 1/35 AF35191



105MM HOWITZER M101A1 & CARRIAGE M2A2



The US Army mainly used foreign cannons in WWI, and following the end of World War I, the Army convened a board to determine the future of U.S. Army artillery. Known as the Westervelt Board after its president, in 1919 the Board recommended that the 105 mm be the divisional gun. The indigenous gun will be able to projectile 30 to 35 pounds ammunition up to 12000 yards.

This 105 mm howitzer adopted modularized cannon and carriage; both of them can be used with other platforms or cannons. By 1928, the howitzer was designated as M1, now with spreadable trails, wooden wheels and shield flaps. However, due to the Great Depression, the project was suspended. By 1934, the howitzer was improved to be able to projectile fixed ammunition, designated as M2. By 1940, further improved M2A1 was introduced, with modified bolt, metal carriage and rubber tires, also electronic breaks for truck towing.

By March 1944, M2A2 was introduced. This version had electronic breaks discarded; and came with modified shield flaps and traversing mechanism. This configuration remained thereafter. In 1962 the artillery designation system was changed and the 105mm M2A1 howitzer became the M101A1. The production was well into post war up to 1953, plus authorized production in foreign countries, M101A1 continues to see service with many other countries.

第一次世界大戦で、米陸軍は外国製の火砲を使用していたが、大戦終結後、将来の米陸軍砲兵に関する検討委員会が召集された。ウェスターベルトの名称で知られる、この委員会は、1919年に口径105mmの砲を標準的な師団砲とすべきとの結論を出した。30～35ポンドの砲弾を12000ヤードの距離に打ち込むことができると判断したからである。

採用された105mm榴弾砲は、砲身と砲架を組み合わせる形で、それぞれ別の砲架への積載や、異なる砲身の搭載などができるように考慮されており、1928年までに、展開式の砲脚、木製の転輪、防御用のシールドを備えた榴弾砲が、M1の名称で設計された。しかし、世界恐慌の影響で、開発は一時延期されてしまう。1934年までに、この榴弾砲は定装式の砲弾が発射できるように改良されたM2が設計され、1940年までに、さらに改良された砲口、金属製車輪にラバータイヤ、車両牽引時のための電気遮断器などを備えたM2A1が開発されたのだった。

1944年3月までに、M2A2が開発された。この型は、電気遮断器が取り除かれ、防盾の形状変更、新砲架が採用され、これ以降この形状が維持されることとなる。1962年、火砲の設計制度の変更に伴い、105mmM2A1榴弾砲は、M101A1と改称される。生産は、大戦後の1953年まで続き、加えて他の国でも生産され、M101A1は、多くの国で運用され続けたのである。

一次世界大戰時美軍大量仰賴由國外採購而來的火砲，大戰結束後隸屬陸軍的韋斯特委員會(Westervelt Board)，負責研究大戰期間有關火砲使用的經驗與教訓，為美軍的發展政策提出建議。1919年韋斯特委員會提出建議，制定105mm口徑為未來輕型榴彈砲的標準，該火砲被要求能夠將30至35磅重的砲彈投射至一萬兩千碼的距離，並著手自力研發。

研發中的105mm榴彈砲，砲身與砲架採取模組化設計，各自保留有搭載於其他載具或安裝其他火砲的安排。到了1928年，具有可展開架尾(Trail)的砲架(Carriage)，並配置了防盾與木輪的105毫米榴彈砲被命名為M1，成為制式武器，但因為緊接著而來的經濟大蕭條，量產的計畫被暫時擱置。到了1934年，火砲經過改良能夠使用彈頭與裝藥整合在一起的定裝式彈藥(fixed ammunition)，改良後被賦予的型號為M2。1940年再改良砲門，砲架改用金屬車輪與橡膠輪胎、增加電力剎車來配合卡車牽引，成為M2A1。

1944年3月後生產的砲架捨棄了電力剎車裝置，並對防盾與方向機進行改良，新砲架的型號為M2A2，至此以後105mm榴彈砲便維持了這一構型。二戰結束後使用M2A2砲架的105mm榴彈砲被重新命名為M101A1，戰後持續生產至1953年，並供應其他國家或授權生產，目前M101A1依然服役於各國的砲兵單位中。

Illustration:圖示說明



因產品中有極精細的部件，請在標記處切除以避免損害零件。
Note: Cut off at here first to avoid damage.

CUT HERE



Method for applying decals:

1. Clean model surface with wet cloth.
2. Cut out of decal sheet and dip them in warm water for 15 seconds.
3. Place it on proper position on model.
4. Slide off base paper leaving decals on model with wet finger tip.
5. Move decals to exact position, push out excess water under decal with soft cotton cloth.
6. When decals get dry then complete.

水貼紙使用說明:

1. 將模型表面擦乾淨
2. 將貼紙剪下泡入溫水中浸泡約15秒
3. 將泡濕之貼紙取出置於欲貼處旁
4. 用指尖輕推貼紙表面使其滑出底紙
5. 將貼紙調整至適當位置並輕擦拭水份
6. 待其自然乾燥後即完成

Color list: 塗料表

Color	Brand	Gunze Sangyo			Humbrol	Revell	Lifecolor
		Hobby Color	Mr.Color	Mr.Color Spray			
Khaki green	卡其綠	H80	C54				
Steel	黑鐵	H18	C28	J28	53	91	LC76
Flat white	消光白	H11	C62	J62	34	05	LC01
Wood brown	木棕	H37	C43		169		FS12
Sail color	帆布	H85	C45		28		UA099
Bronze green	青銅綠		TC10				
Leather brown	皮革棕		TC11				
Tar black	瀝青		TC12				
Flat black	消光黑	H12	C33	J33	33	8	LC02
Brass	黃銅	H9	C9	J9	54	92	LC75
Flat red	消光紅	H13			73		LC06
Olive drab(1)	橄欖綠	H52	C12	J12	155		UA15
Radome	天線罩	H318	C318		148		DR06
Dark earth	深土	H72	C22		29	87	UA72
RLM71 Dark green	深綠	H64	C17		116		UA52
RLM80 Olive green	橄欖綠		C120				UA138

105mm Howitzer M2A1

● The howitzer was adopted by the US Army in 1939, became the standard light field howitzer for the US Army in World War II, seeing action in all theatres. 10202 were produced in WWII.

● Being a close support weapon, its shield was designed to protect operating soldier's lower portion.

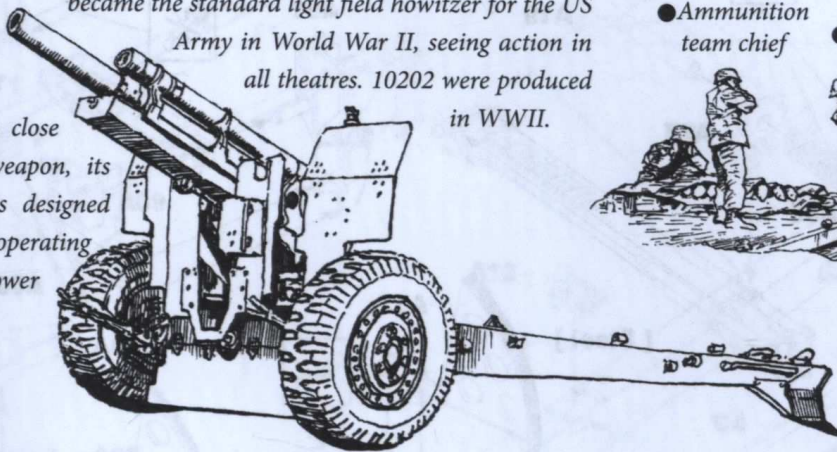

● Ammunition team chief ● Aimer ● Loader ● Gunner



● 10 personnel, towed by a 2 1/2 ton truck

● M101A1 was modified (lightened) from M2A1. Adopted by more than 70 countries after WWII. Total production number is 494.

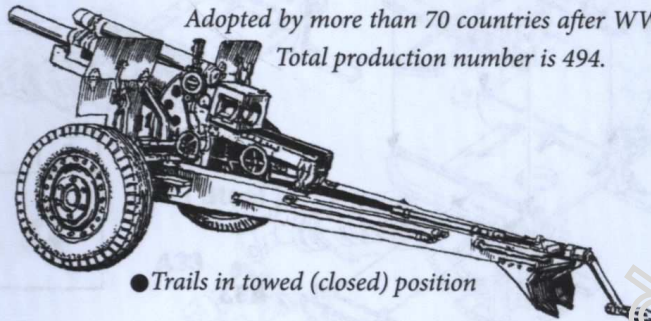

● Trails in towed (closed) position

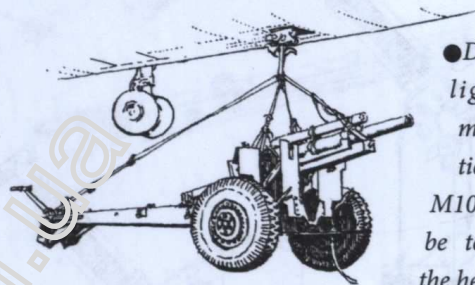

● Due to its lightened modification, the M101A1 can be towed by the helicopter.

● T19 self-propelled artillery vehicle, saw action in the North Africa theatre before M7 Priest was introduced.



● A USMC experimental short-range self-propelled vehicle

● Using M3 chassis (later also M4A3) as the platform, adopting 105mm howitzer, the new self-propelled artillery vehicle was known as M7 Priest.



shin.ueda

● M5 3-inch Anti-Tank Gun
Realizing the inadequacy of M1 57mm gun, the M5 3-inch Anti-Tank Gun was developed in short time, commenced to produced by end of 1941.

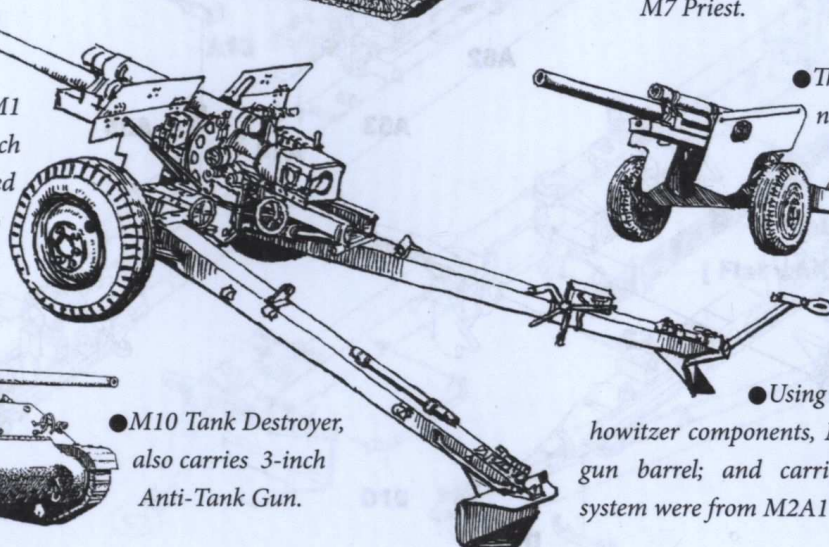

● The M5 adopted new M6 carriage.



● M10 Tank Destroyer, also carries 3-inch Anti-Tank Gun.

● Using existing 105mm howitzer components, M3 anti-aircraft gun barrel; and carriage and recoil system were from M2A1 howitzer.

1

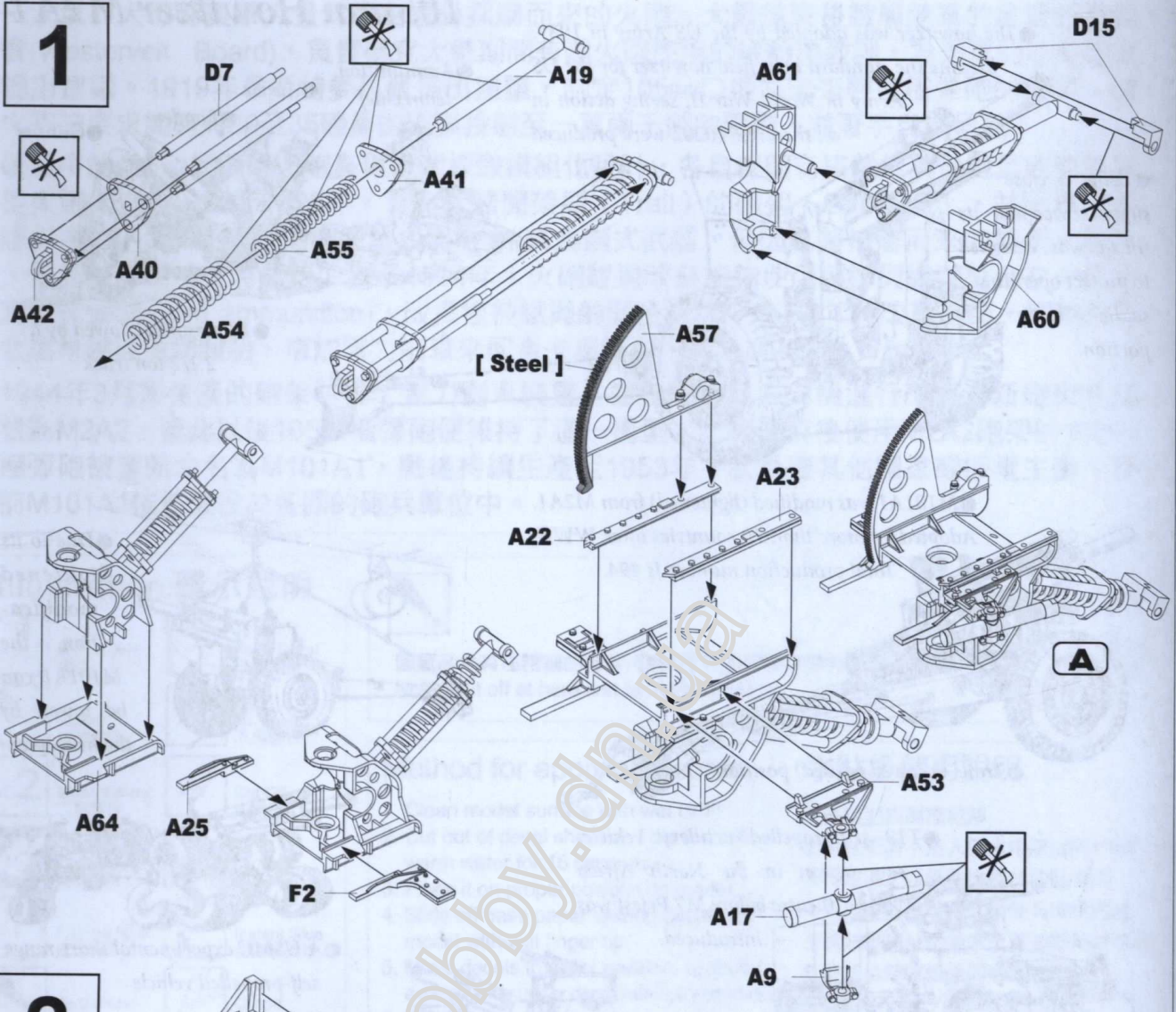

2

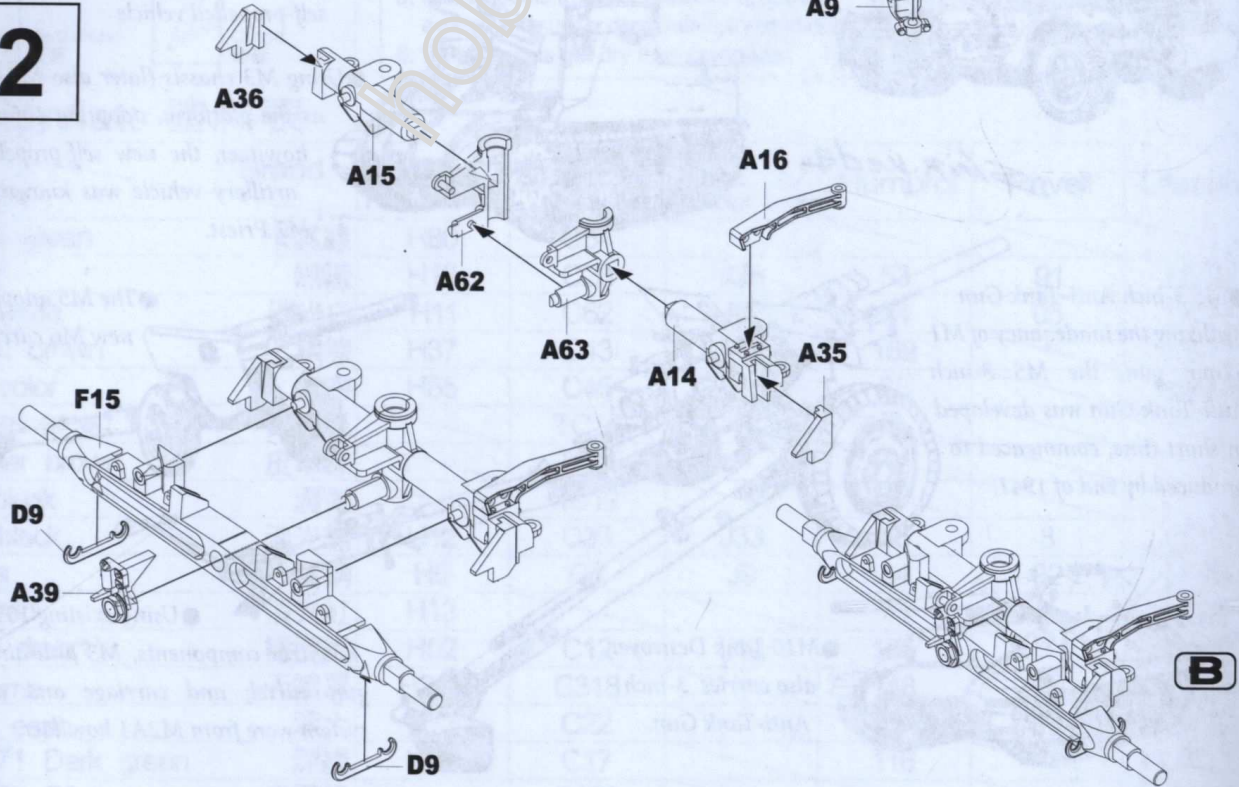

3

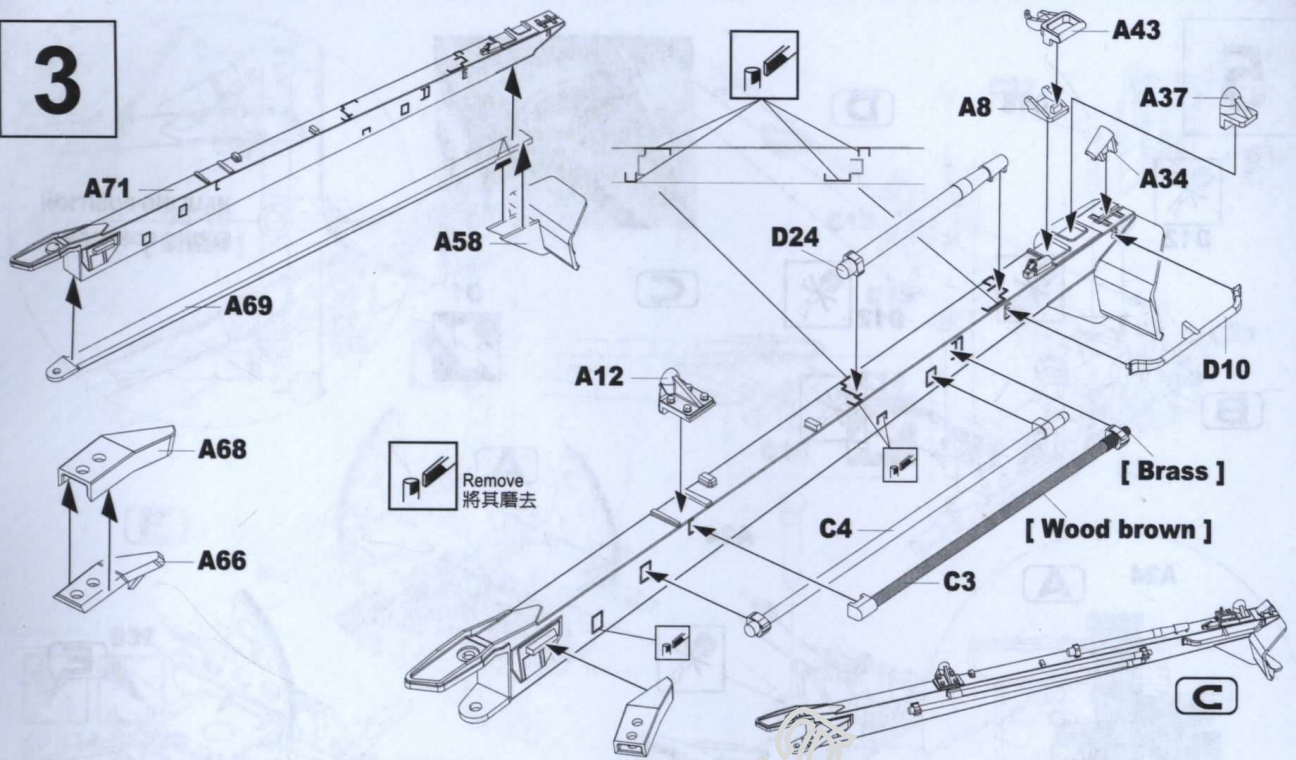

4

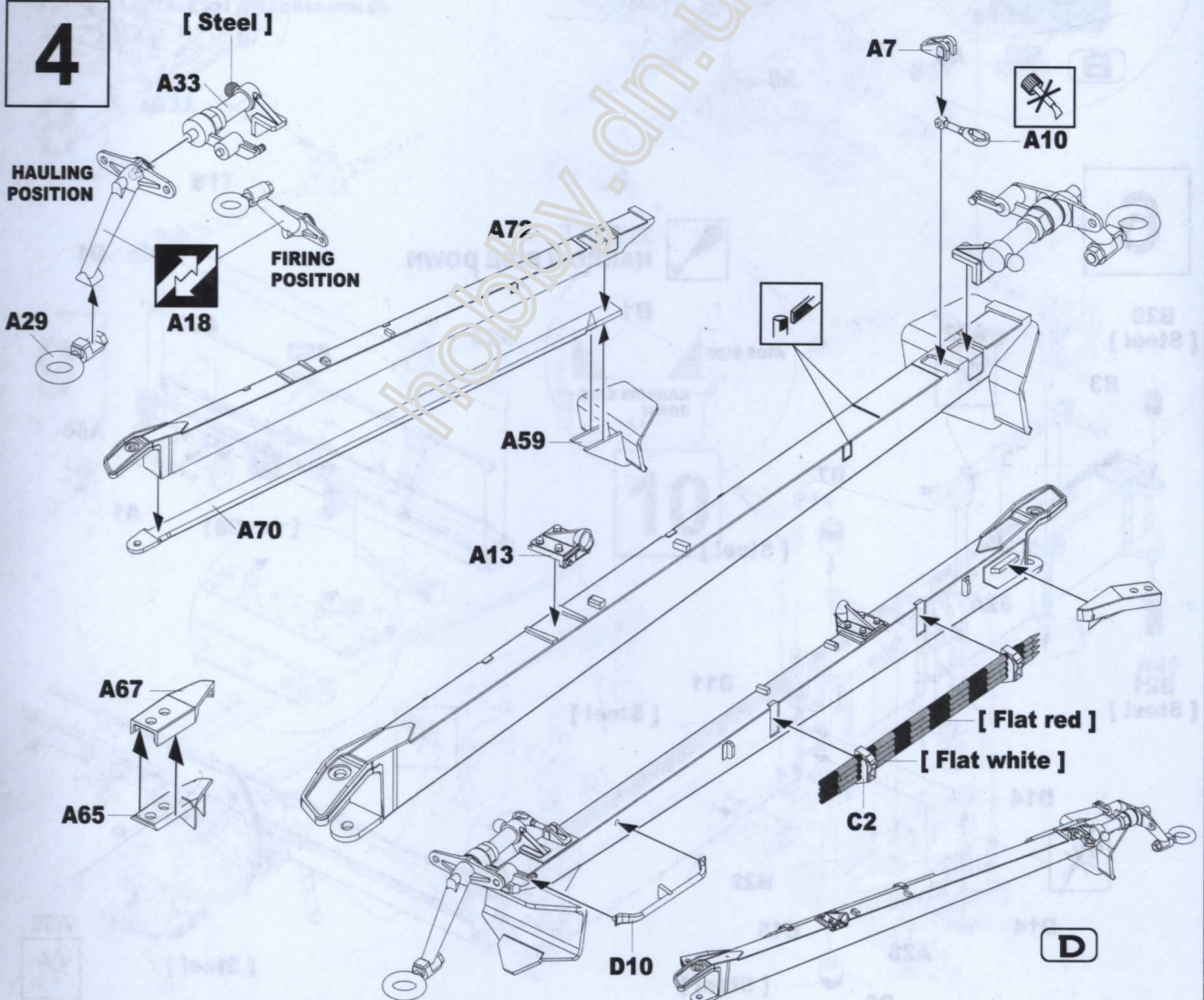

5

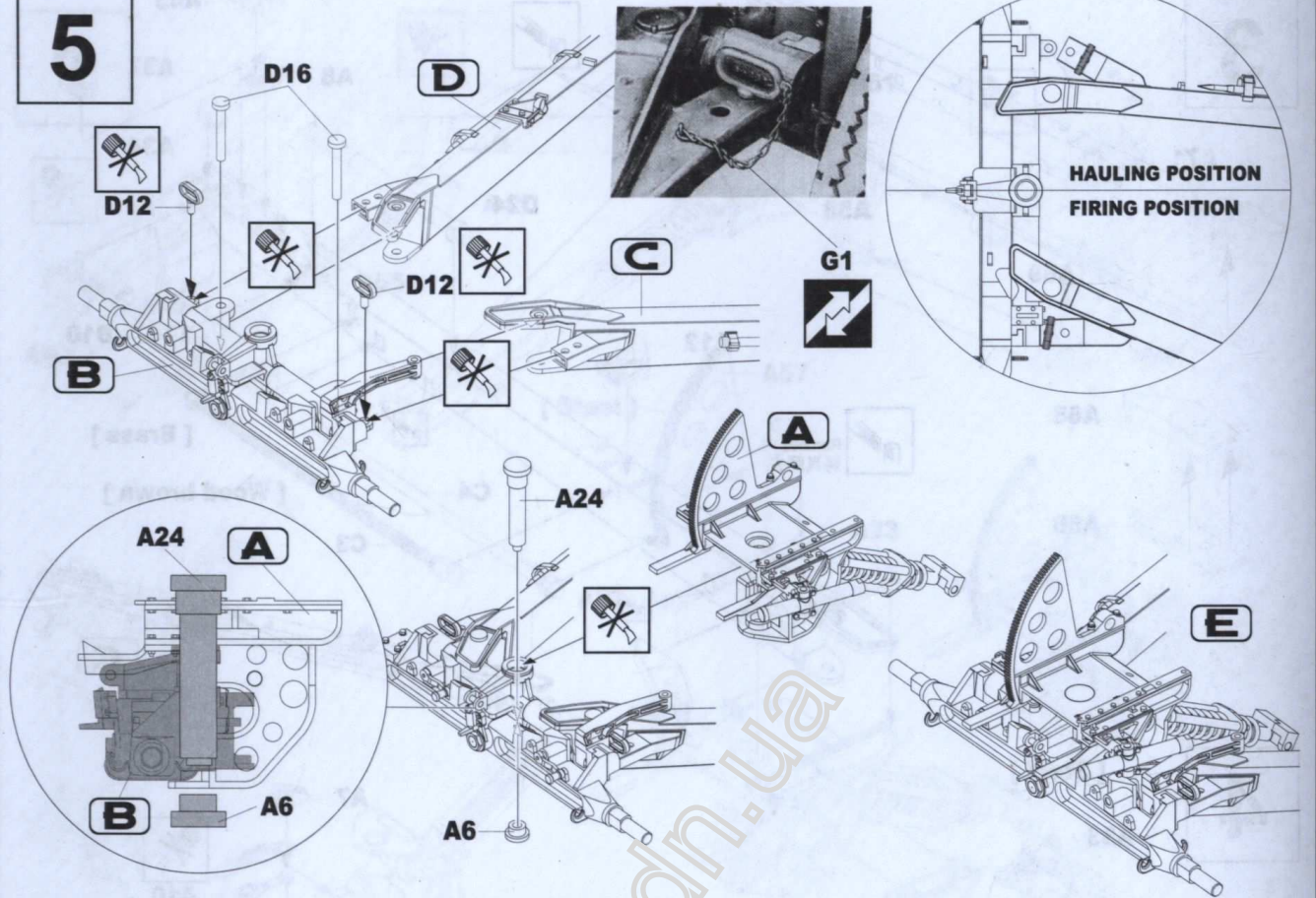

6

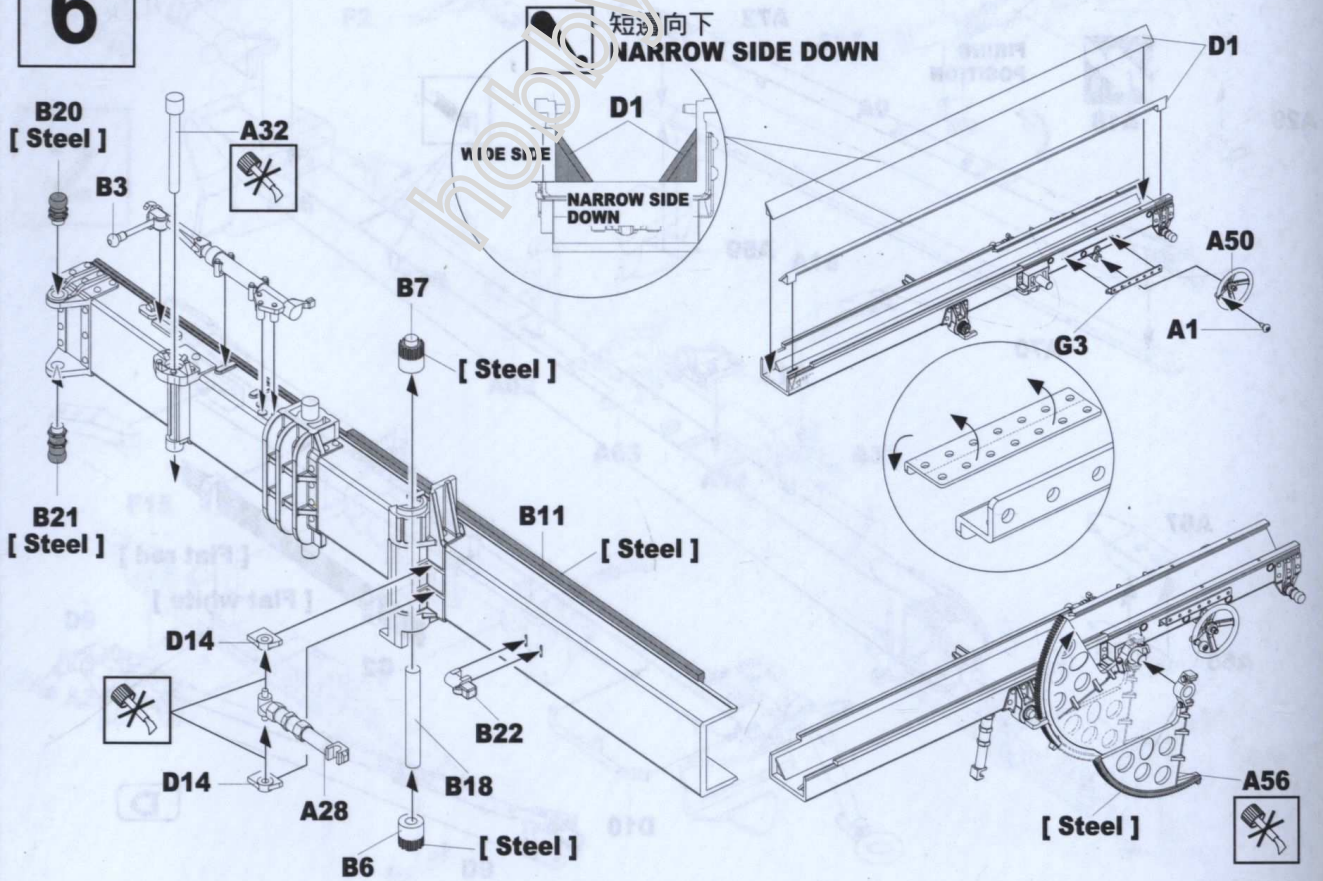

7

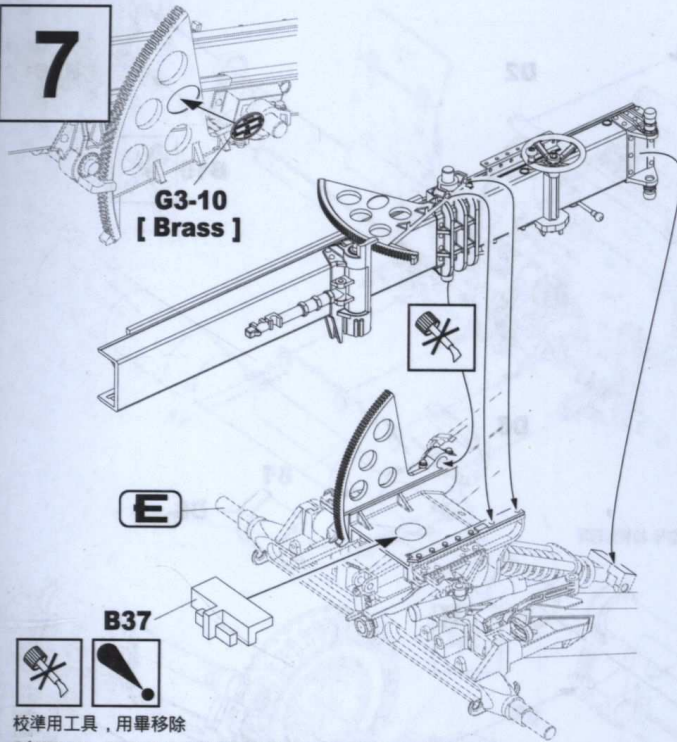

G3-10
[Brass]

E

B37



校準用工具，用畢移除

CAUTION : B37 IS A TEMPORARY PART FOR FITTING AND POSITIONING, REMOVE B37 AFTER ASSEMBLED.

8

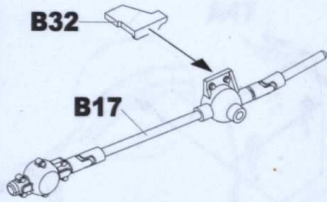

B32

B17

9

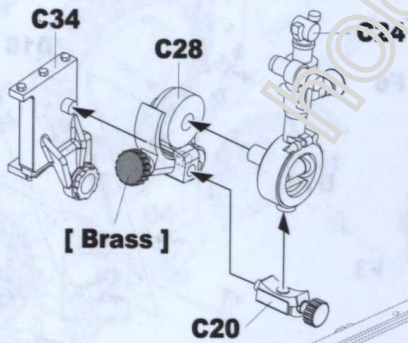

C34

C28

C24

[Brass]

C20

10

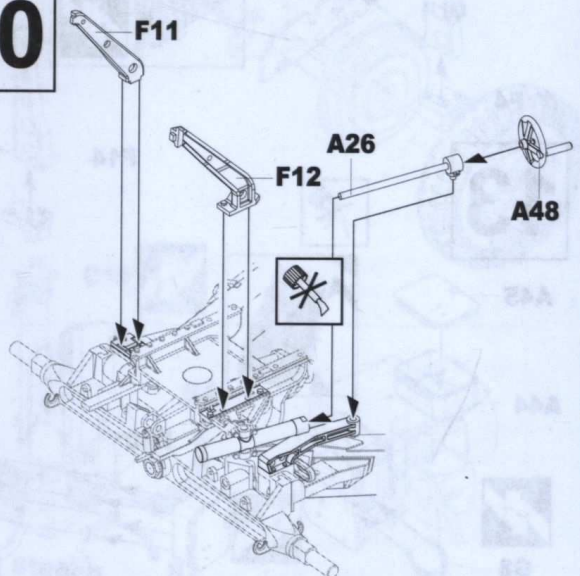

F11

F12

A26

A48

C19

C22

F

C13

C23

C14

C18



C21

F

B31

B8

11

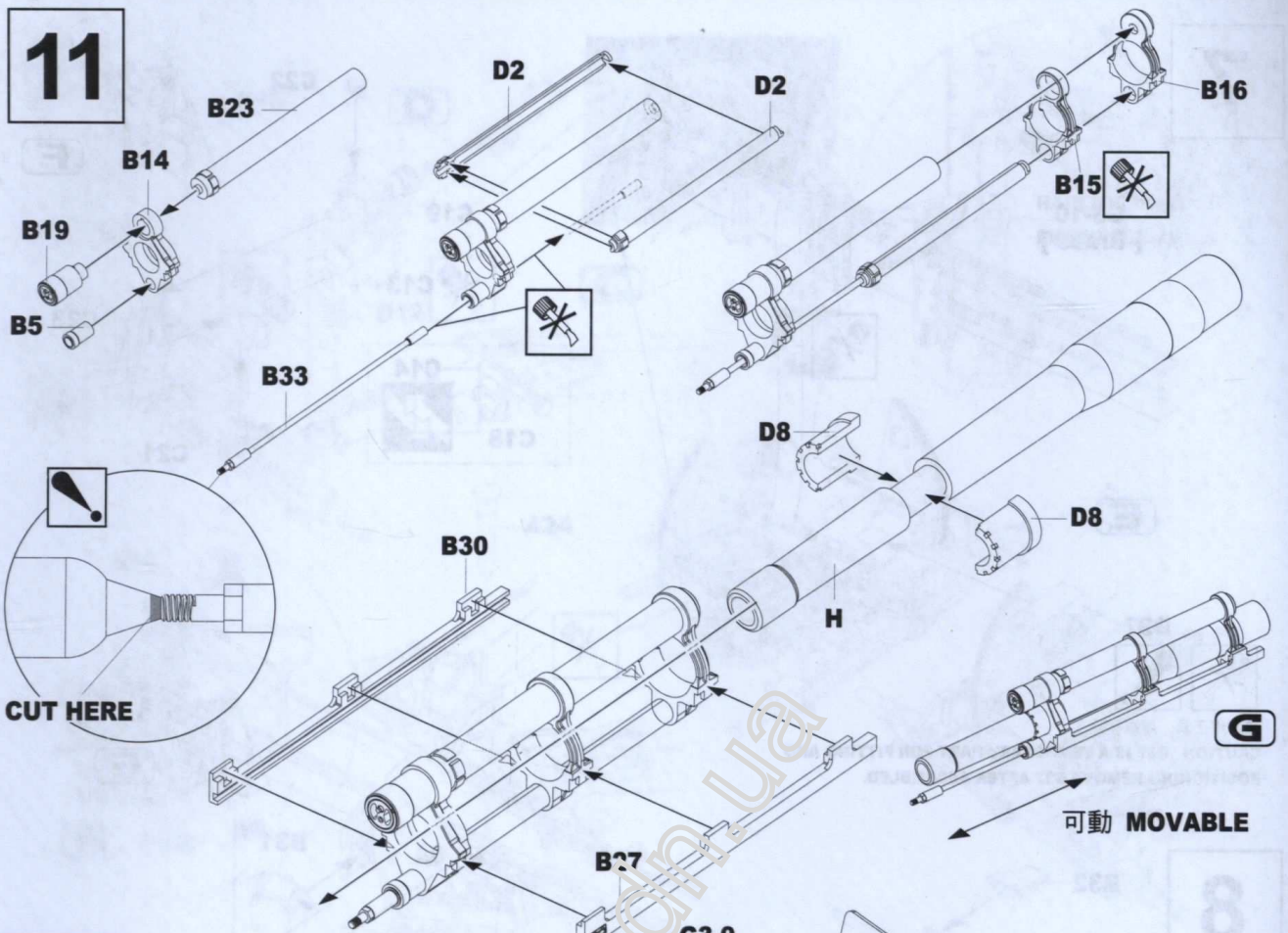

12

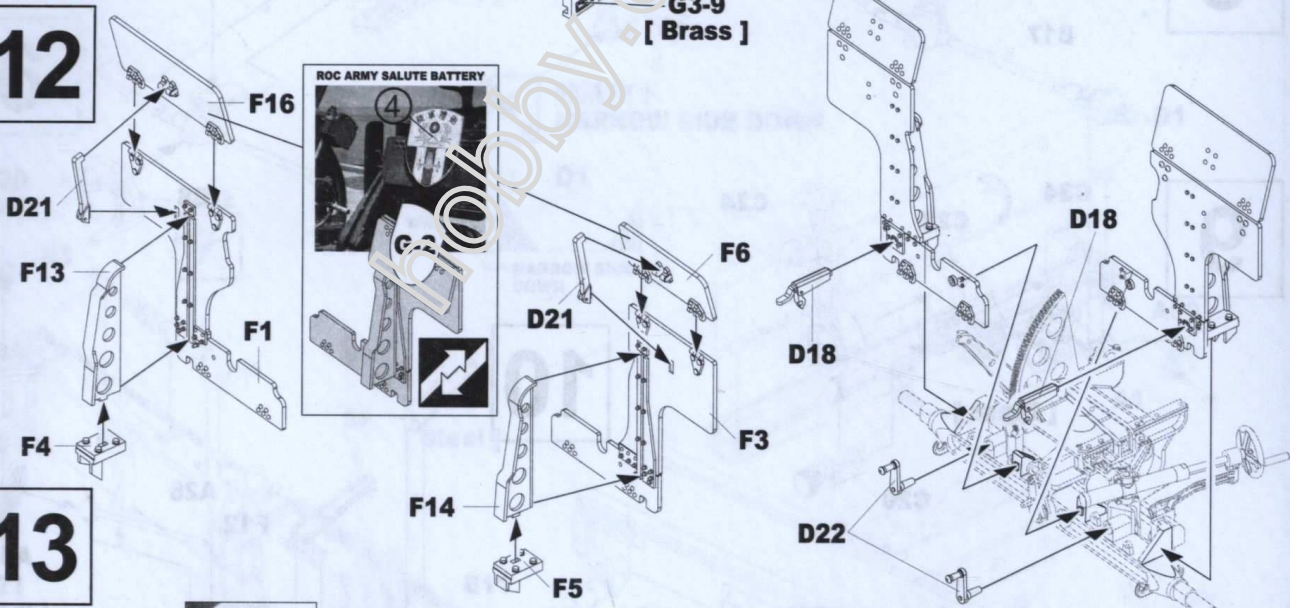

13

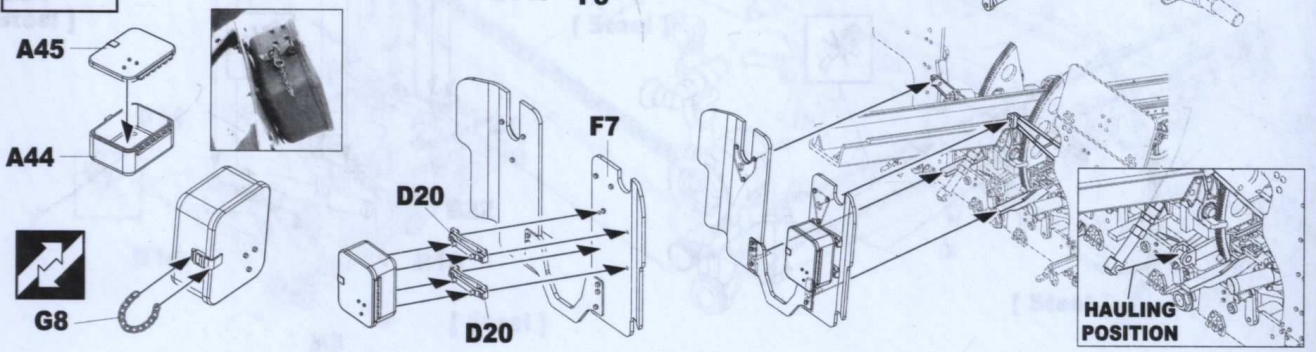

14

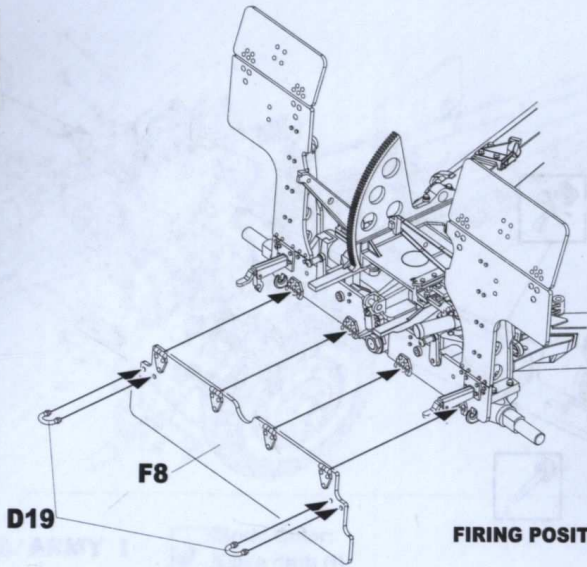

FIRING POSITION

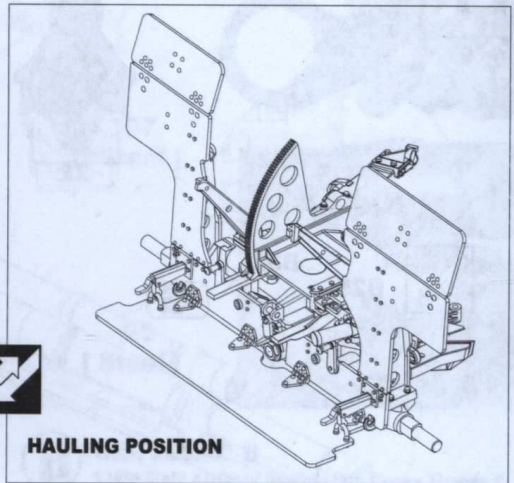

HAULING POSITION

15

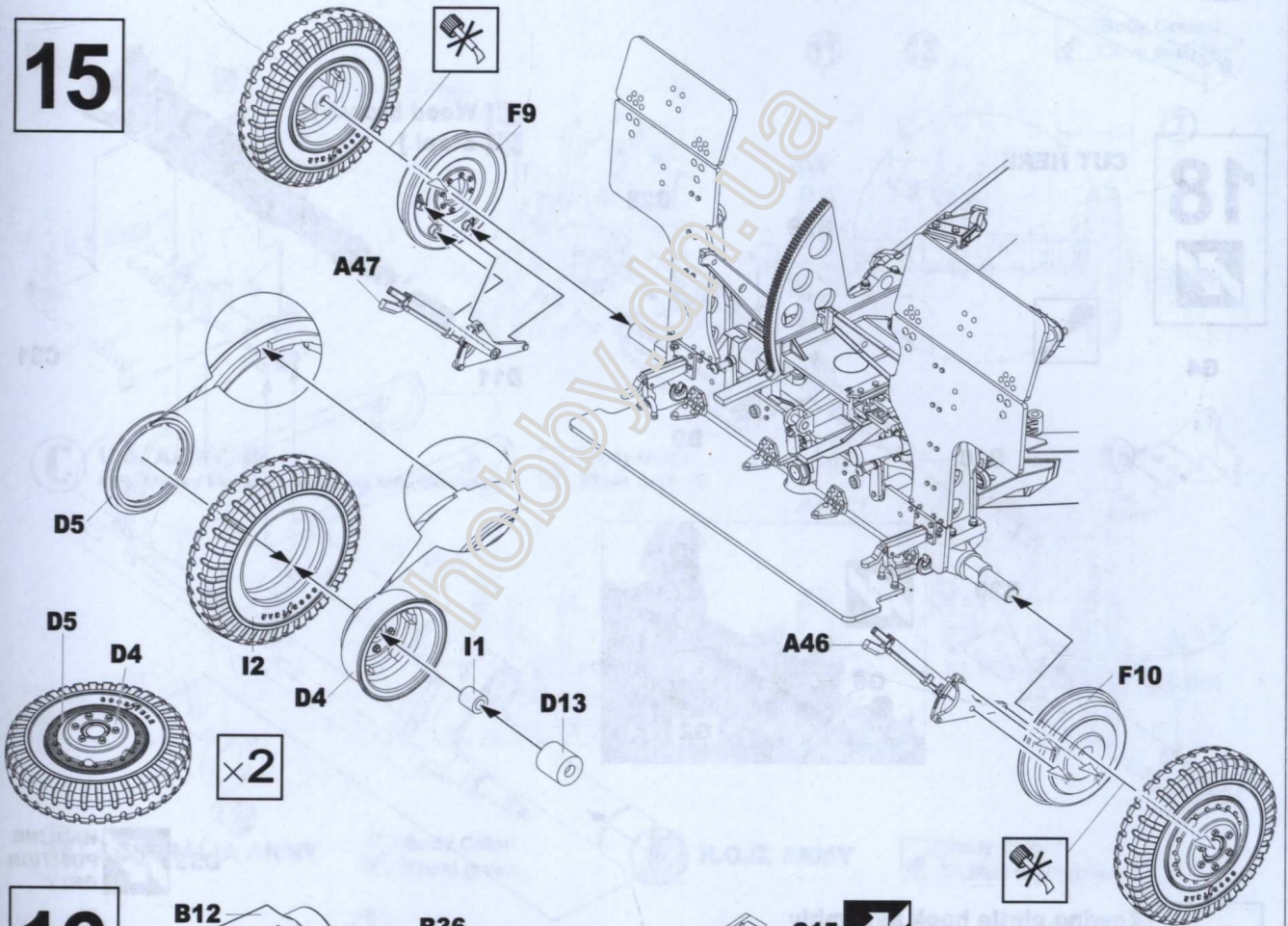

16

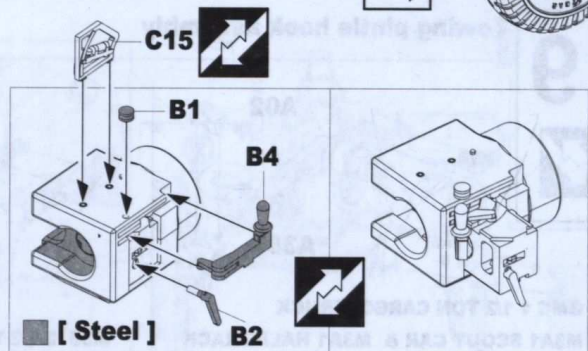
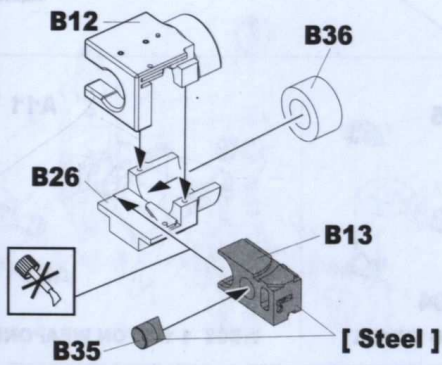

17

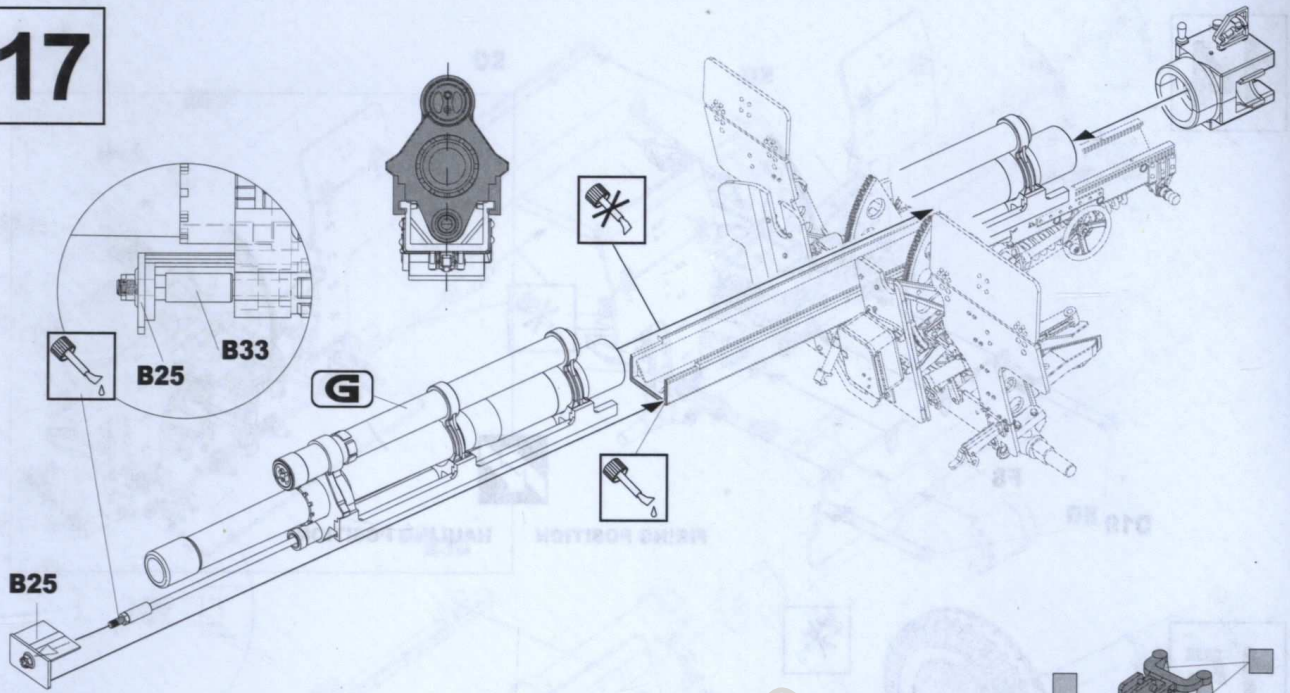

18

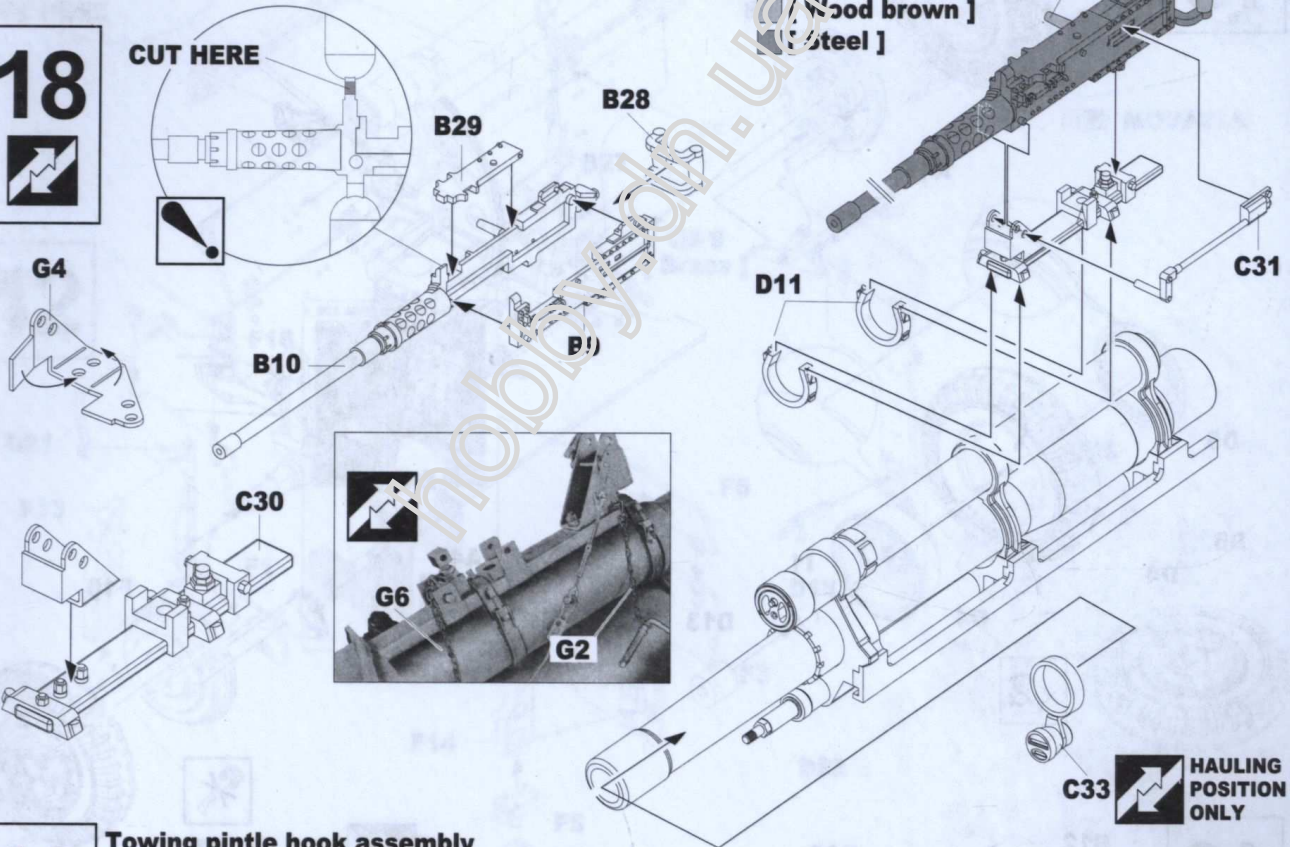

19

Towing pintle hook assembly

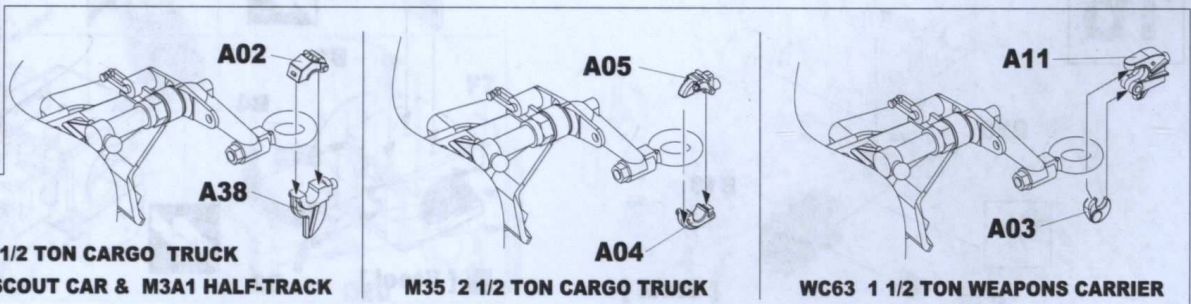

GMC 1 1/2 TON CARGO TRUCK
M3A1 SCOUT CAR & M3A1 HALF-TRACK

M35 2 1/2 TON CARGO TRUCK

WC63 1 1/2 TON WEAPONS CARRIER

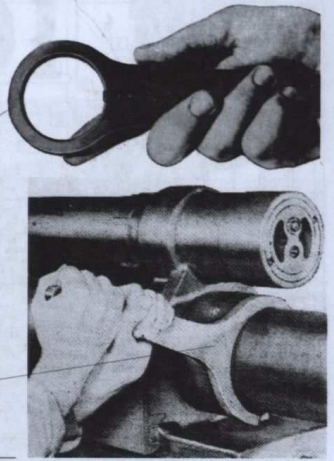
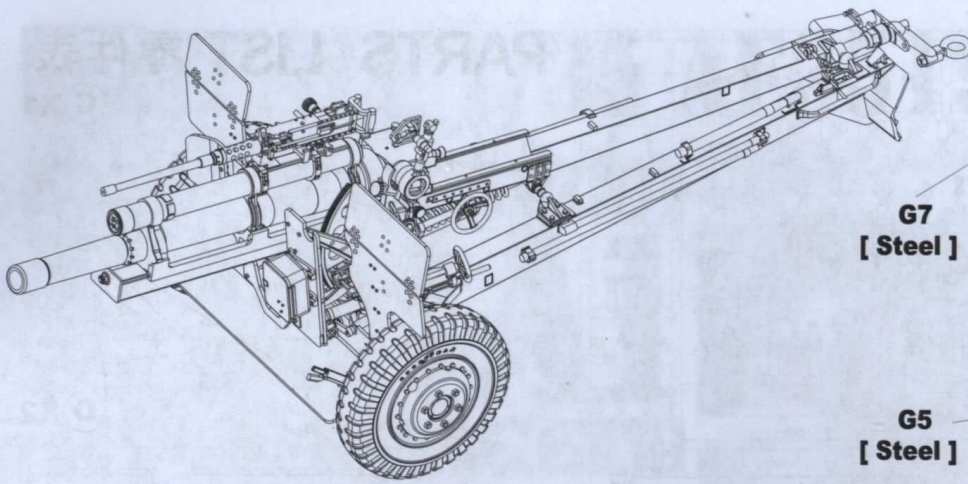

G7
[Steel]

G5
[Steel]

A U.S. ARMY I

Body Color:
Olive drab (1)

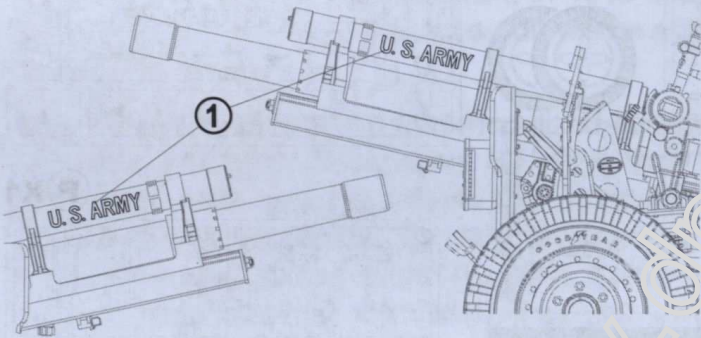

B U.S. ARMY II

138th Field Artillery Brigade "Kentucky Thunder"

Body Color:
Olive drab (1)

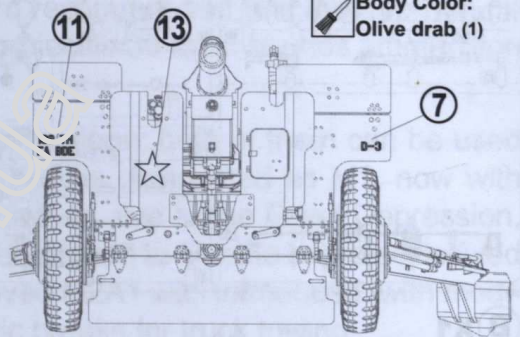

C U.S. ARMY III

45th Infantry Museum - Oklahoma City, Oklahoma

Body Color:
Olive drab (1)

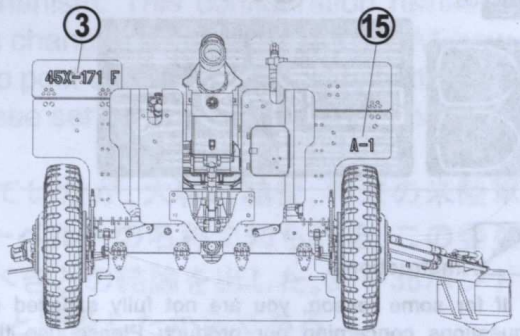
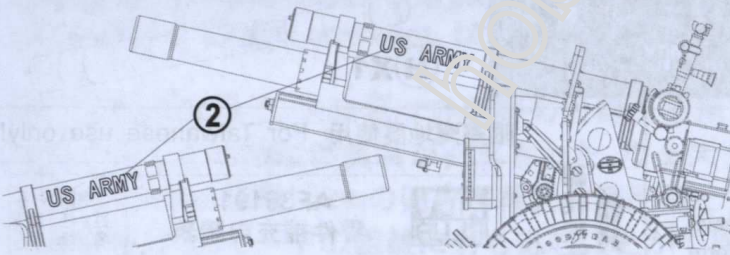

D AUSTRALIA ARMY

Body Color:
Khaki green

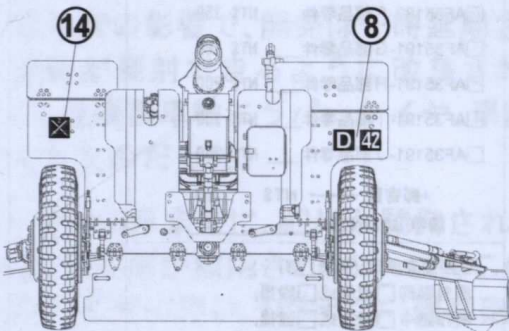

E R.O.C. ARMY

Body Color:
RLM80 Olive green

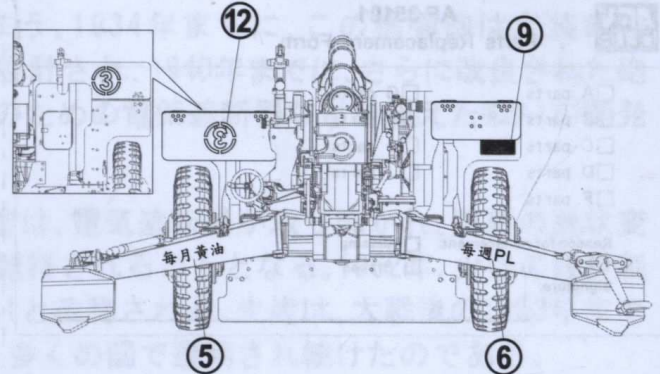

PARTS LIST 零件表

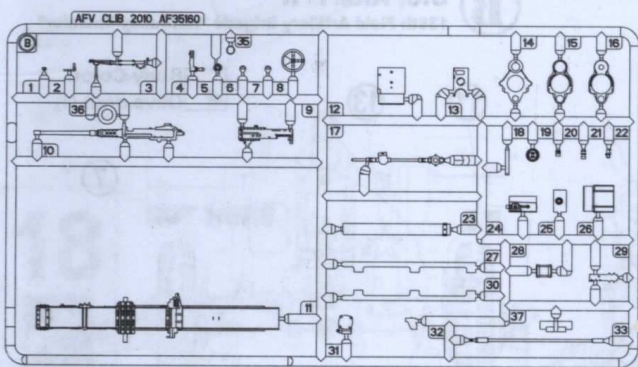
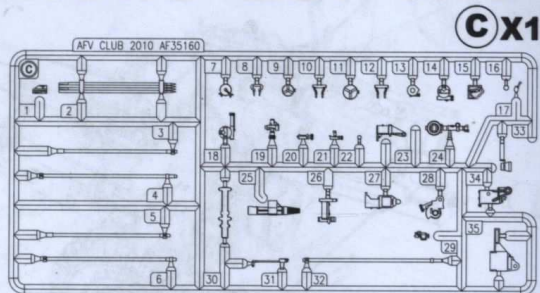
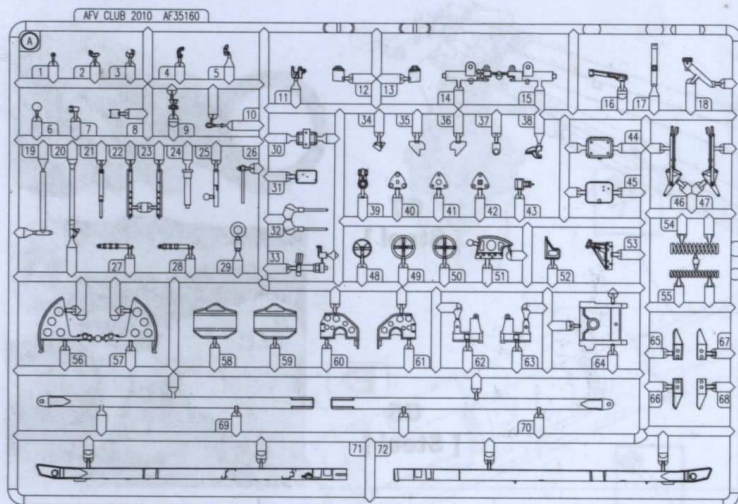

A X1

I X1

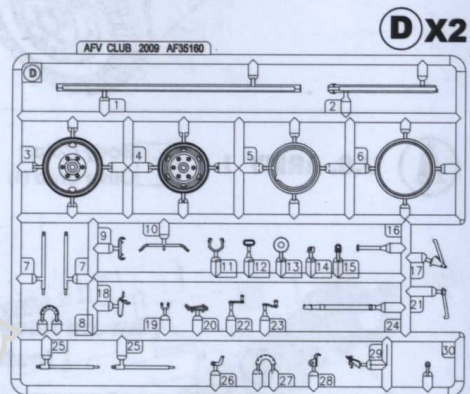
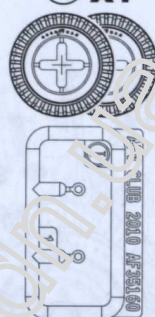

D X2

B X1

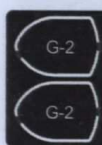

G X1

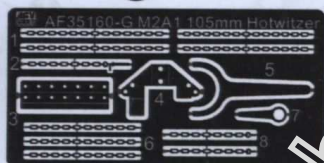

J X1

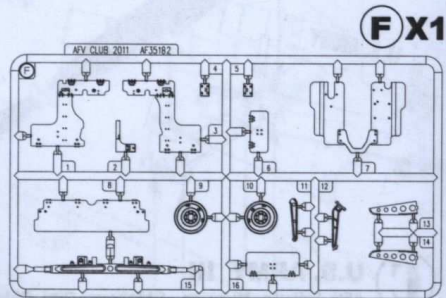

F X1

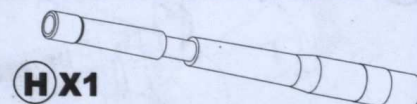

H X1



Instructions:

If for some reason, you are not fully satisfied or have questions concerning our product; Please use the form provide, and send it to our nearest representative or mail it directly to our office.

We will deal with that A.S.A.P.



AF 35191 Parts Replacement Form

- | | |
|----------------------------------|----------------------------------|
| <input type="checkbox"/> A parts | <input type="checkbox"/> G parts |
| <input type="checkbox"/> B parts | <input type="checkbox"/> H parts |
| <input type="checkbox"/> C parts | <input type="checkbox"/> I parts |
| <input type="checkbox"/> D parts | <input type="checkbox"/> J parts |
| <input type="checkbox"/> F parts | |

Reason for replacement: Missing Broken

Signature: _____

限臺灣地區使用 For Taiwanese use only!

總代理戰鷹企業客服部收本公司將儘速為您處理。
請將本表與該部品相同金額之郵政匯票一同寄至



AF35191 零件補充申請表

申請人
姓名 地址 電話

- | | |
|---|----------|
| <input type="checkbox"/> AF35160-A 部品零件 | NT\$ 250 |
| <input type="checkbox"/> AF35160-B 部品零件 | NT\$ 220 |
| <input type="checkbox"/> AF35160-C 部品零件 | NT\$ 180 |
| <input type="checkbox"/> AF35160-D 部品零件 | NT\$ 300 |
| <input type="checkbox"/> AF35182-F 部品零件 | NT\$ 150 |
| <input type="checkbox"/> AF35191-G 部品零件 | NT\$ 180 |
| <input type="checkbox"/> AF35191-H 部品零件 | NT\$ 200 |
| <input type="checkbox"/> AF35191-I 部品零件 | NT\$ 100 |
| <input type="checkbox"/> AF35191-J 部品零件 | NT\$ 200 |

+郵寄費 _____ NT\$ 80

(請填)總計NT\$ _____

零件補充原因:(請於 打)
原包裝即 遺失或 毀損,
製作途中 遺失或 毀損,
其他原因 _____



1/35 SCALE

AF35191



105MM HOWITZER M101A1

& CARRIAGE M2A2
105mm榴弹砲M101A1

COLOR INDEX



F R.O.C. ARMY SALUTE BATTERY

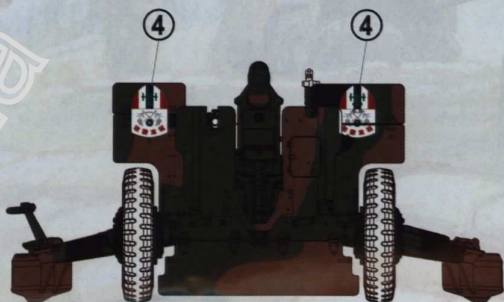
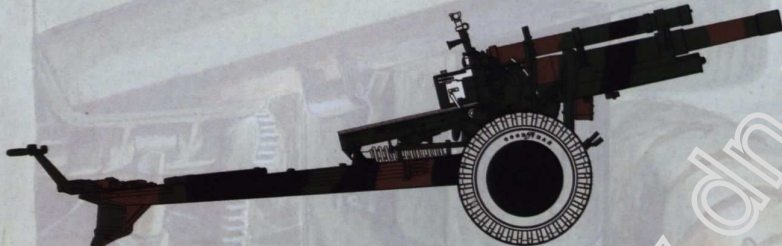
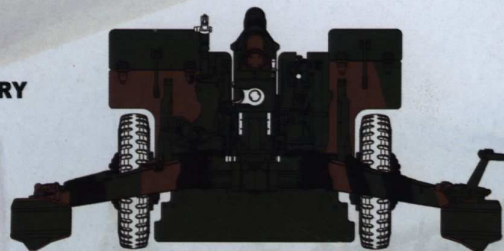

Bronze green

Leather brown



Tar black



G KOREA ARMY

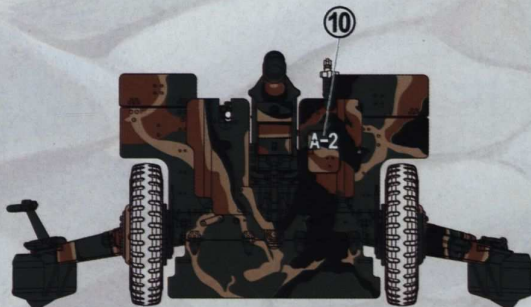
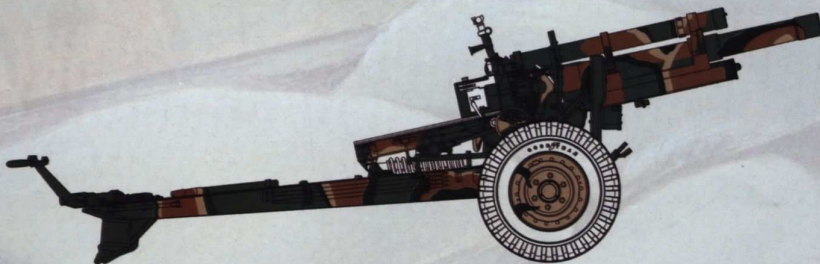
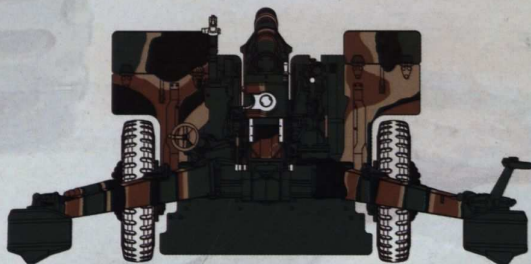

Flat black



Radome



Dark earth



RLM71 Dark green