



Schwere Panzerspähwagen
Sd.Kfz.232(8Rad)
early type

While Hitler was appointed chancellor in 1933, he got public support to withdraw Germany from League of Nations and World Disarmament Conference. New wheeled armored car designs were expedited. To meet different tactical requirements, new wheeled armored car designs covered 4-wheel and 8-wheel versions. All of them adopted independent suspension and all wheel drive, all wheel steering chassis as well as larger size tires to optimize off road capabilities and maneuverability. The armour was designed to provide protection from small arms fire and HE fragments, also future improvement possibilities.

Büssing-NAG, who was mainly a truck manufacturer, accepted the new 8-wheel specification in 1934, started this "Army new heavy off-road truck" project and completed 2 prototype heavy cars in 1935. Both cars adopted identical specification, the only difference is one of them have spare space for radio sets. The test was carried on till September 1935. Mass production commenced by end of 1934, designated as Sd.Kfz.233/234. They have dual steering at the front and rear, also the first German armored cars that come with basket turrets. By 1939, the German Army decided to replace 6-wheel versions Sd.Kfz.231/232(6-Rad) with 8-wheel version Sd.Kfz.231/232(8-Rad). The designation was carried over; differentiation is made by the addition of 6-Rad or 8-Rad. The Sd.Kfz. 232 early type added a Fu.11 SE100 set, yet the most distinguishable feature in appearance was a square antenna on top of the vehicle. Although slightly greater in weight, yet Sd.Kfz.232 enjoyed much the same maneuverability as Sd.Kfz.231.

Early Sd.Kfz.231/23 was equipped with a KwK30 L/55 20mm gun and a 7.92mm axial machine gun, same as that of on Panzer II. A total of 607 units of Sd.Kfz.231/232 were produced from 1936 until 1943. They saw services in North African and European theaters. With excellent maneuverability, they were largely used in reconnaissance and fire-covering missions.

1933年、ドイツ首相に任命されたヒトラーは、世論の支持を得て、国際連盟と世界軍縮会議から脱退する。それと同時に、新型の装輪式装甲車の開発が加速されたのであった。異なる戦術的 要求に応えるため、新型装甲車は、4輪と8輪の2つのバージョンが設計された。これらの車輛にはすべて、全輪独立懸架装置および全輪駆動、全輪ステアリング機構が採用されるとともに、大型タイヤの装備により、高速走行と路外での走破性の向上が図られていた。装甲は、小口径の火器による射撃や、榴弾の破片に耐えられるよう設計され、将来的な改良の余地を持たせてあった。

1934年、トラック製造メーカーであった、ビュッシング-NAG社は新型8輪装甲車の仕様を受け取り、「陸軍新型重路外トラック」なる秘匿名称のもと、開発をスタートさせ、1935年には2種類の試作車を完成させた。両者とも同じ規格で造られており、を完成させた。両者とも同じ規格で造られており、唯一の違いは、無線機搭載のスペースの有無のみであった。テストは1935年9月まで続けられ、Sd. Kfz233/234として1936年末に量産が開始された。この装甲車は、前と後ろに2つの操縦席を持ち、ドイツの装甲車輛として初めて砲塔内にバスケットを装備した。ドイツ陸軍は、1939年までに6輪装甲車Sd. Kfz231/232(6-Rad)を8輪装甲車Sd. Kfz231/232(8-Rad)に置き換えることを決定した。形式名称はそのまま継承されたため、「6-Rad」「8-Rad」を末尾に付け加えることで、6輪型と8輪型を区別したのだった。Sd.Kfz.232初期型は、Sd.Kfz.231にFu.11 SE100型無線器を搭載。最も大きな外見上の特徴は、車体上部に設置されたフレームアンテナであった。若干の重量増があったものの、Sd.Kfz.232は、Sd.Kfz.231とほぼ同等の高い走行性能を発揮することができたのであった。

初期型であるSd. Kfz231/232は、II号戦車と同じくKwK30 L55 20mm機関砲と7.92mm同軸機銃を装備。1936年から1943年までに607輛が製造され、ヨーロッパや北アフリカ戦線などドイツ軍のあらゆる戦場でその姿を見ることができ、卓越した機動性により、偵察任務から火力支援まで幅広く用いられ、活躍したのだった。

1933年希特勒掌權之後,德國退出國際聯盟及世界裁軍會議,並加速全新的輪型裝甲車的發展。為適應不同的戰術需要,新型輪型裝甲車包含了四輪與八輪兩種設計,均採用了獨立懸吊與全輪驅動,擁有更大尺寸的輪胎適應高速行駛並提高路外性能。車身裝甲被要求能抵禦任何角度的7.92公厘穿甲彈射擊,同時也保留了後續的升級改良空間。

以生產卡車為主的布辛納格(Bussing-NAG)在1934年初接受了以“國防軍重型越野貨車”為名義掩護的新型八輪裝甲車設計委託,在1935年完成了兩輛原型車的製造,兩部原型車採用相同的規格,差異僅在於其中一輛預留了搭載無線電的空間,測試持續至1935年9月份為止。量產則開始於1936年年底,最初賦與的制式型號為Sd.Kfz.233/234,特點為擁有前後兩組駕駛系統,具備全輪操向能力,也是最早採用砲塔吊籃的德國裝甲車輛。到了1939年,德軍決定以該八輪裝甲車汰換Sd.Kfz.231/232(6-Rad),並繼承其型號成為Sd.Kfz.231/232(8-Rad),其中Sd.Kfz.232初期型增設了Fu.11 SE100型無線電,在外觀上與Sd.Kfz.231差異最大的特徵來自車頂的方型無線電天線。Sd.Kfz.232的車身重輻稍有增加,但運動性能與Sd.Kfz.231卻相差無幾。

初期型的Sd.Kfz.231/232搭載了與II號戰車相同的KwK30 L/55 20公厘戰車砲與7.92公厘同軸機槍,由1936開始投產起至1943年Sd.Kfz.231/232停產時總共生產了607輛。在歐洲與北非的戰場中,Sd.Kfz.231/232以其優越的機動力,在裝甲部隊中稱職的擔任偵察與掩護的任務。

Illustration:圖示說明



Method For Applying Decals:

1. Clean Model Surface With Wet Cloth.
2. Cut Out Of Decal Sheet And Dip Them In Warm Water For 15 Seconds.
3. Place On proper position on model.
4. Slide off base paper leaving decals On Model With Wet Finger Tip.
5. Move Decals To Exact Position, Push Out Excess Water Under Decal With Soft Cotton Cloth.
6. When Decals Get Dry Then Complete.

水貼紙使用說明:

1. 將模型表面擦乾淨
2. 將貼紙剪下泡入溫水中浸泡約15秒
3. 將泡濕之貼紙取出置於欲貼處旁
4. 用指尖輕推貼紙表面使其滑出底紙
5. 將貼紙調整至適當位置並輕擦拭水份
6. 待其自然乾燥後即完成

Color list: 塗料表

Color	Brand	Gunze Sangyo			Humbrol	Revell	Lifecolor
		Hobby Color	Mr.Color	Mr.Color Spray			
German gray	德國灰	H32	C40	J40	92	79	UA073
Flat white	消光白	H11	C62	J62	34	05	LC01
Steel	黑鐵	H18	C28	J28	53	91	LC76
Silver	銀	H8	C8	J8	11	90	LC74
Tire black	輪胎黑	H77	C33+C62		85	302	LC02
Wood brown	木棕	H37	C43		169		FS12

1

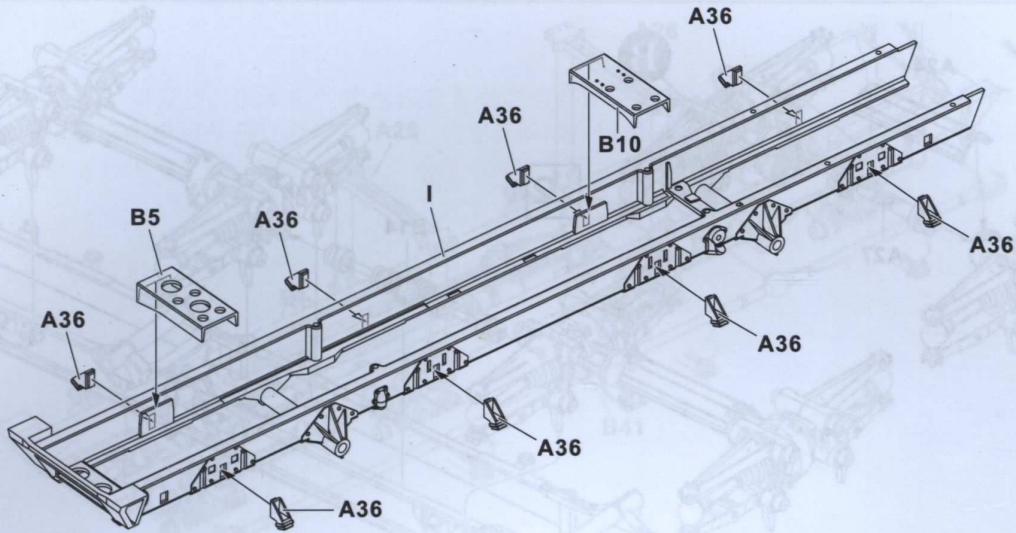

2

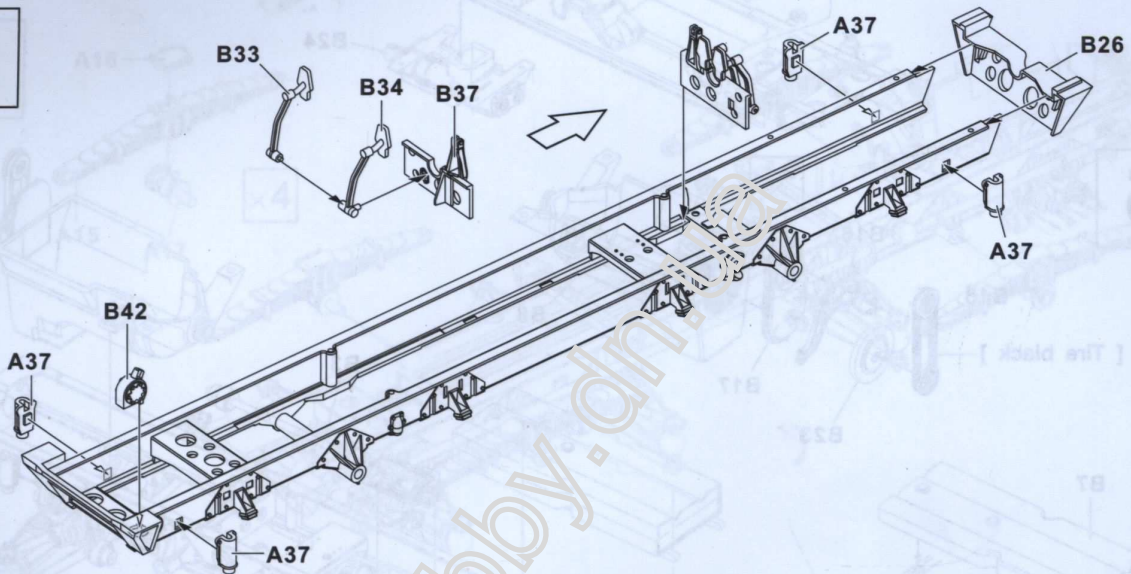

3

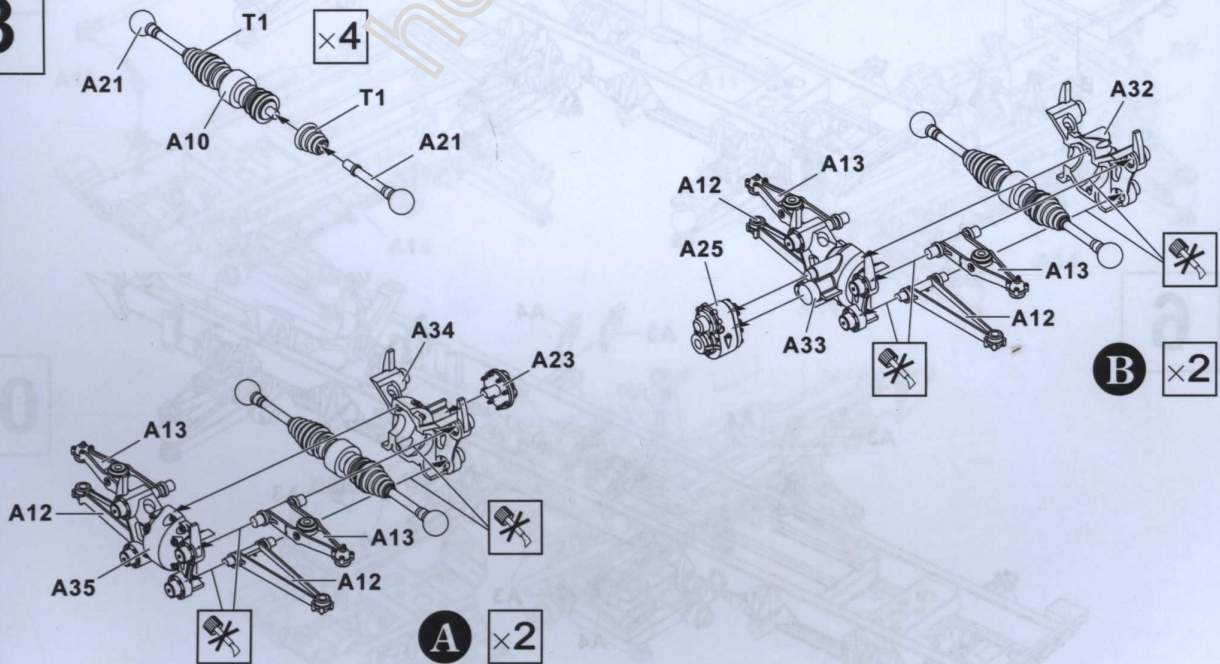

4

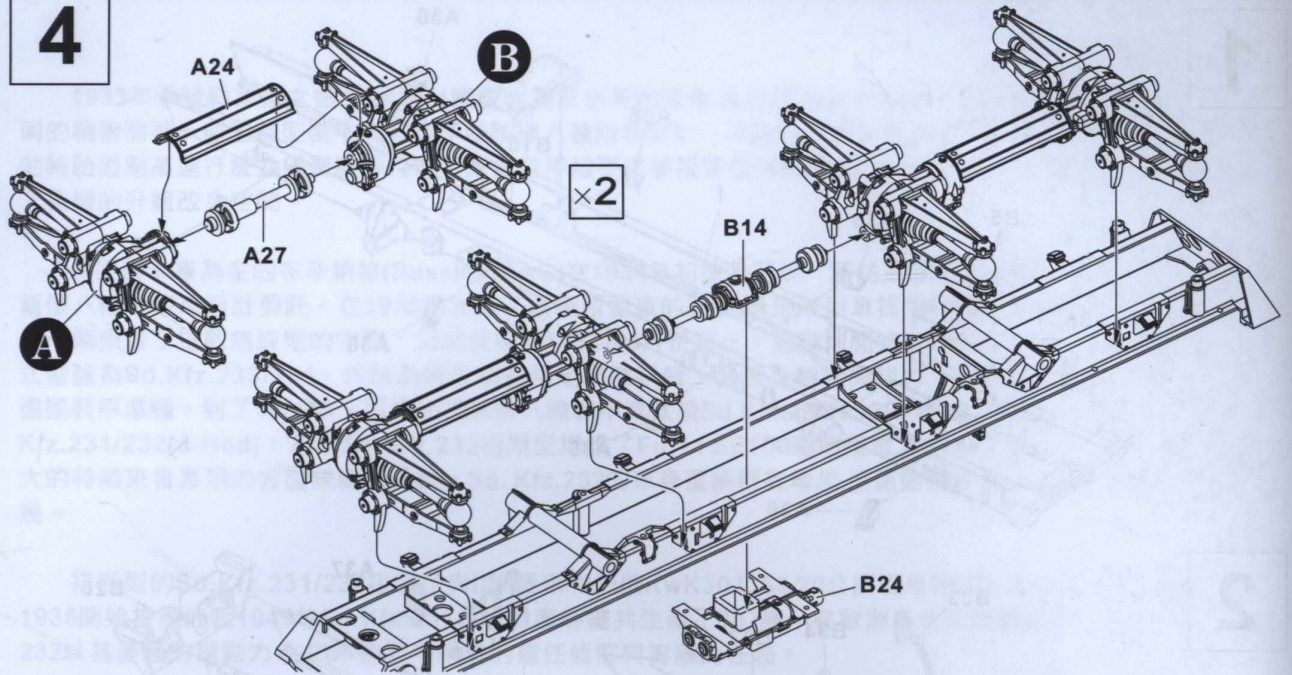

5

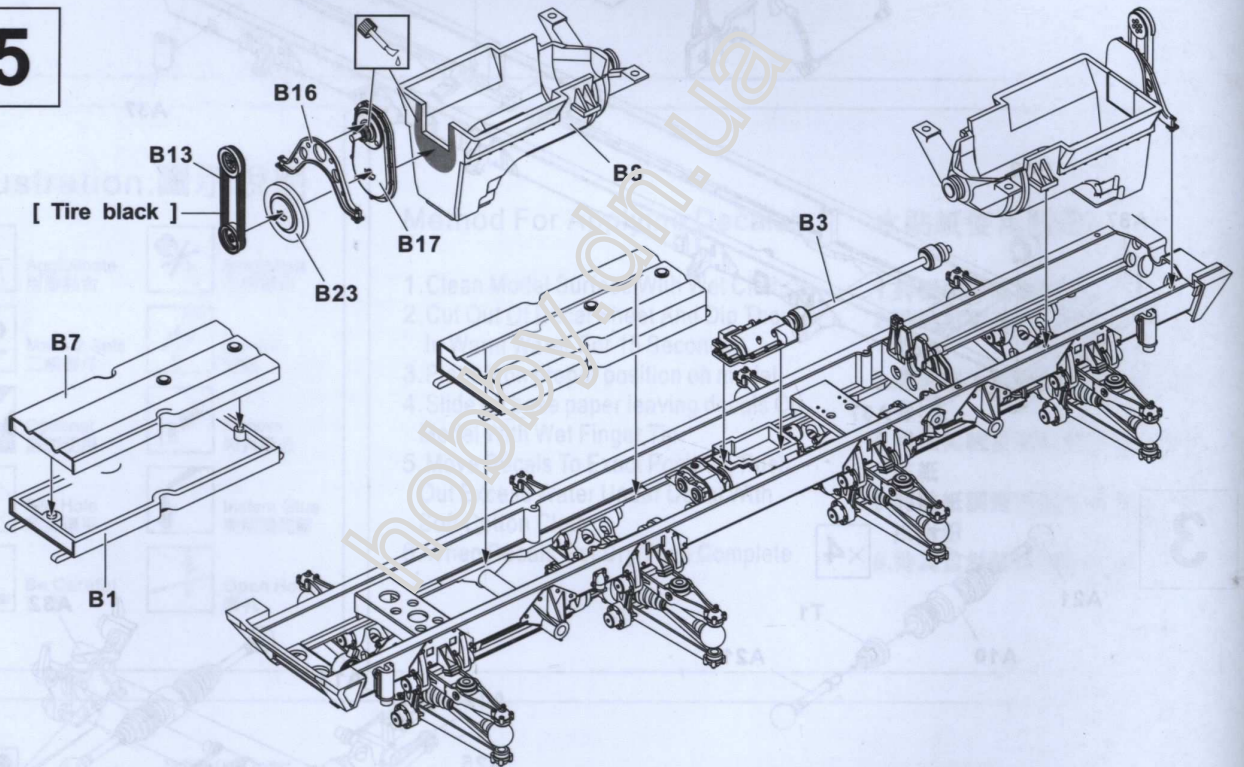

6

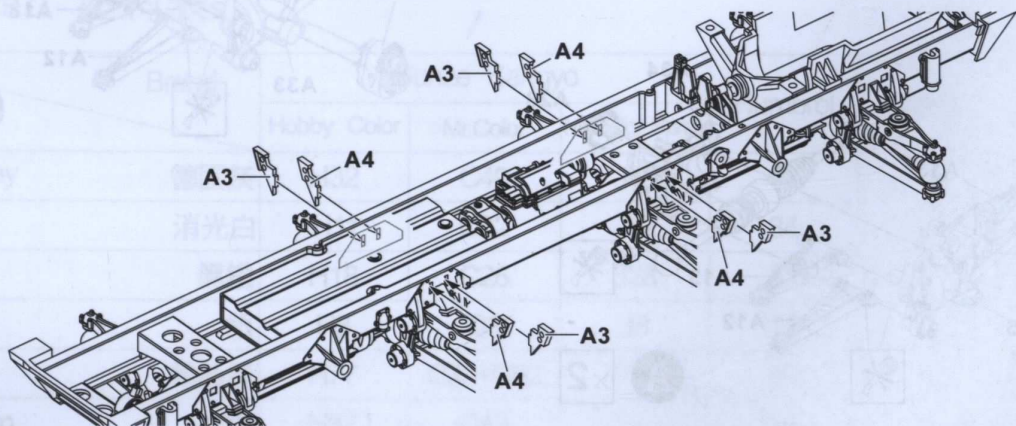

7

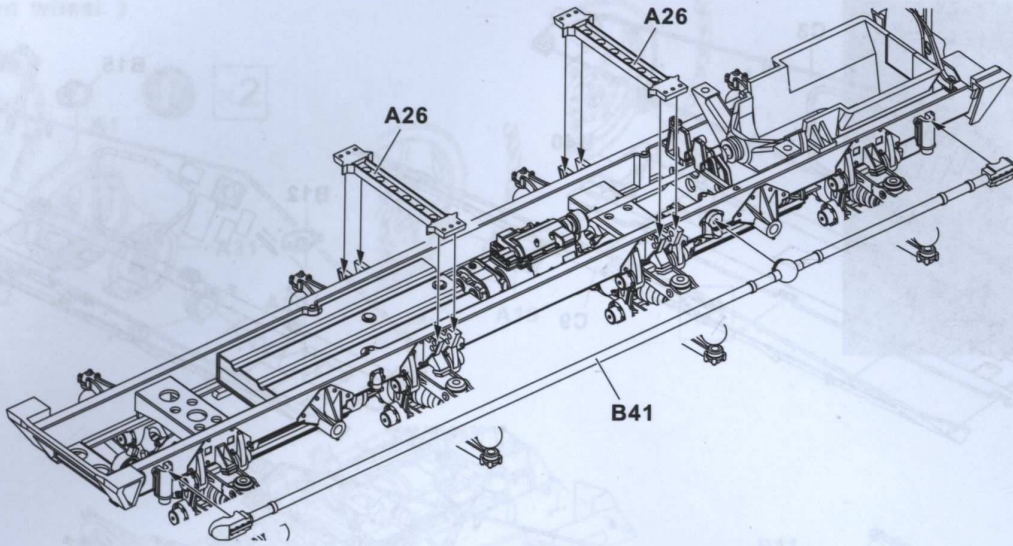

8

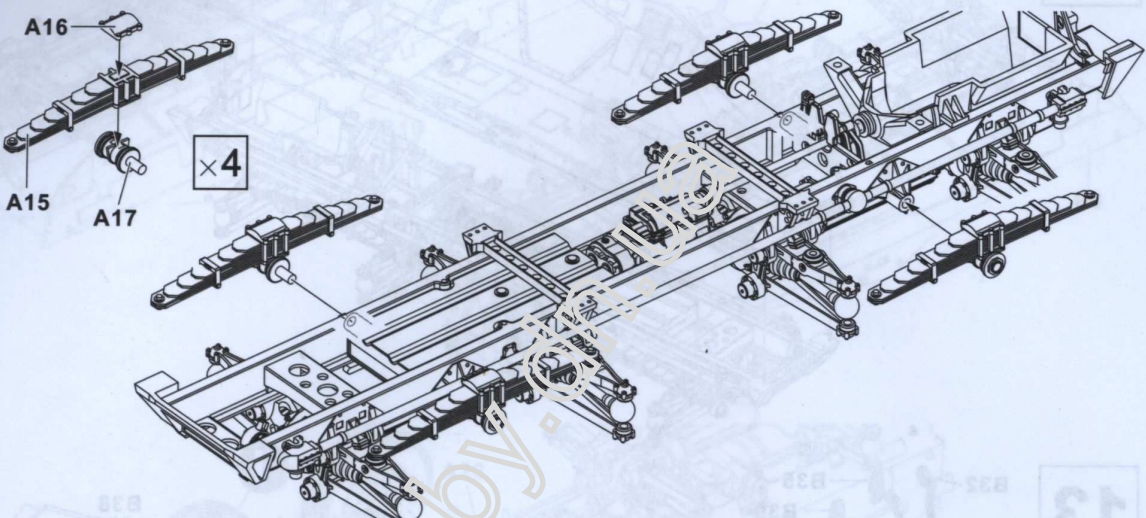

9

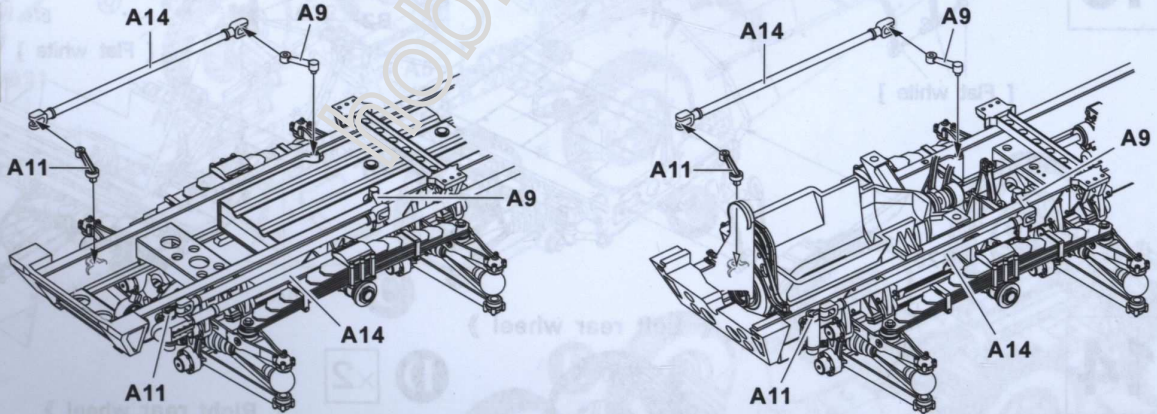

10

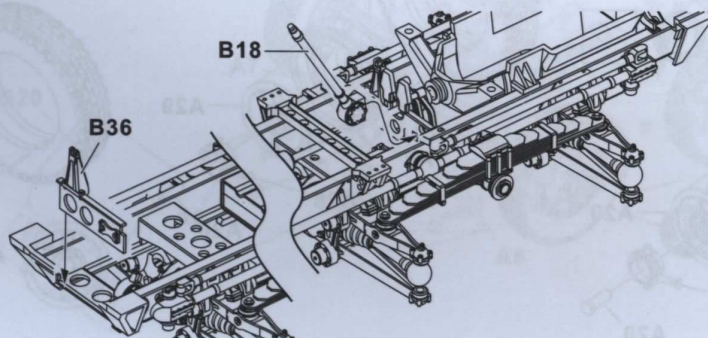

11

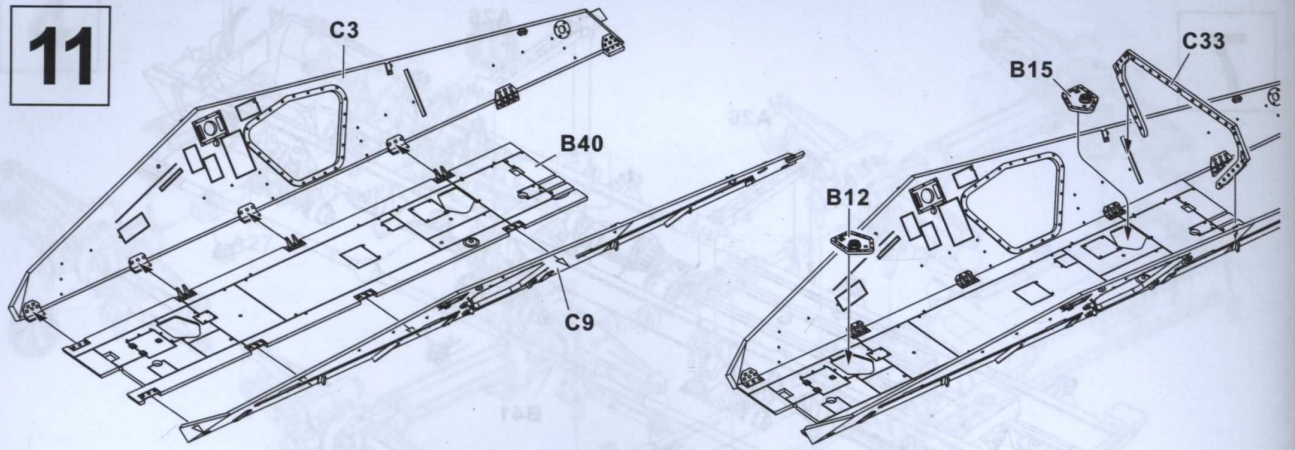

12

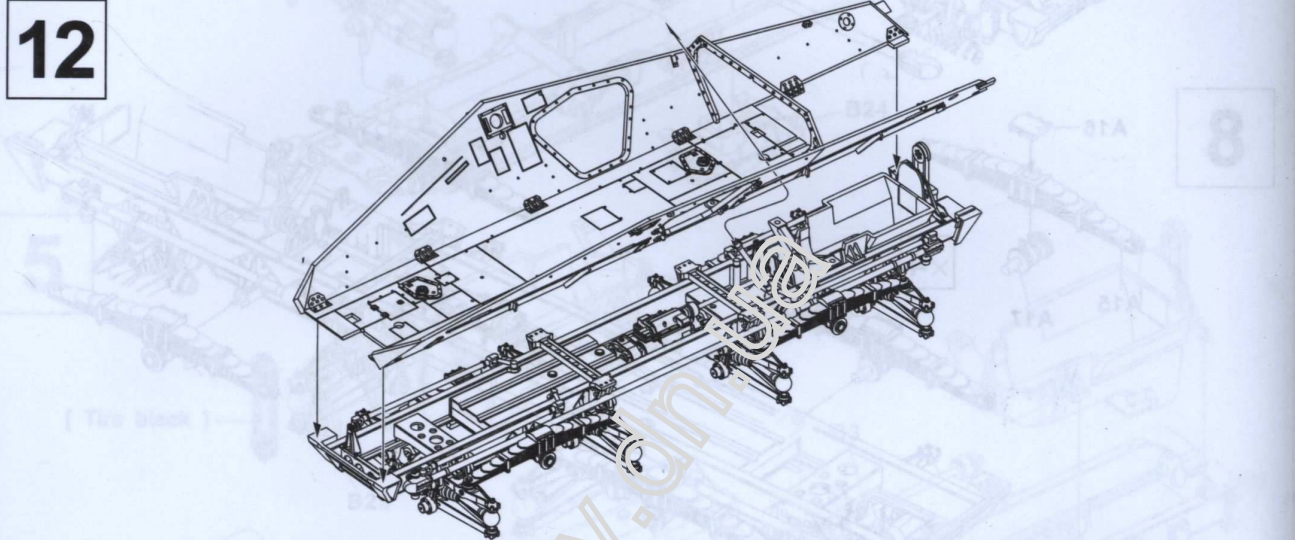

13

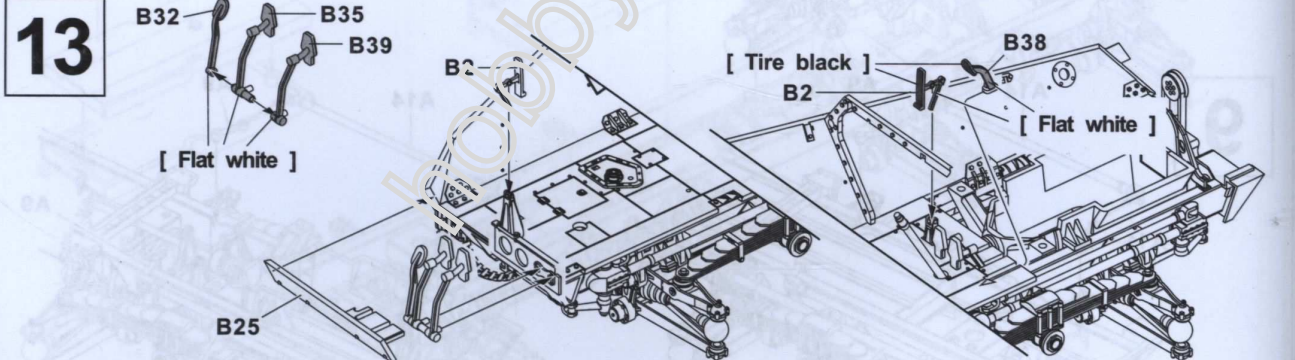

14

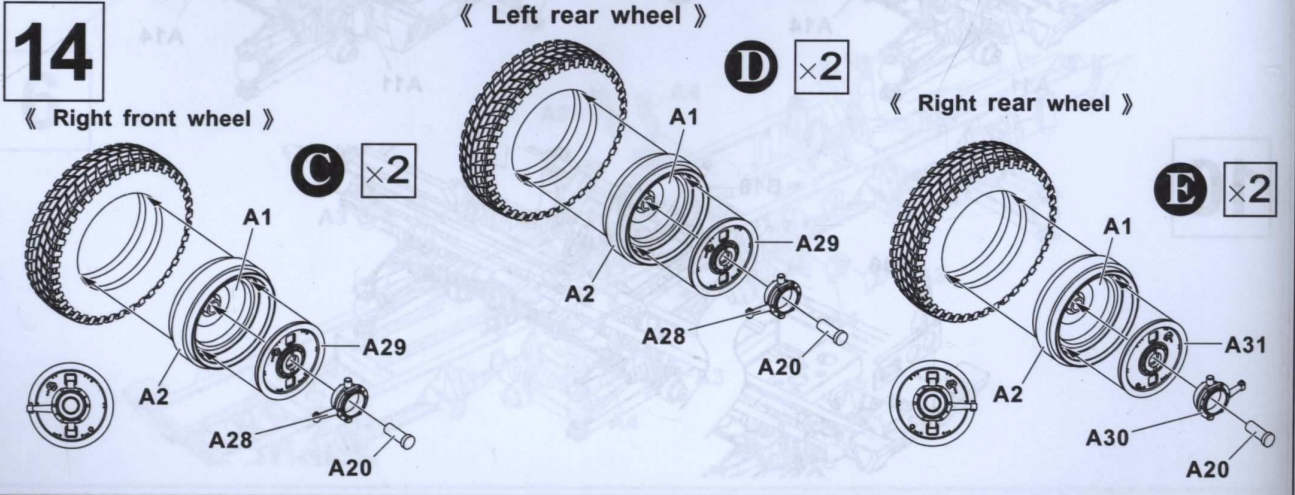

« Left front wheel »

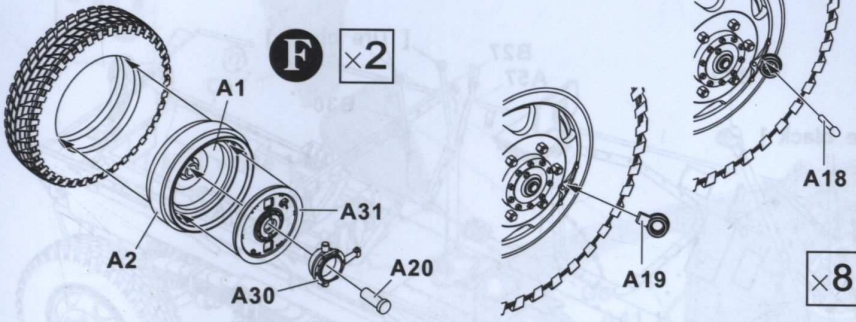

15

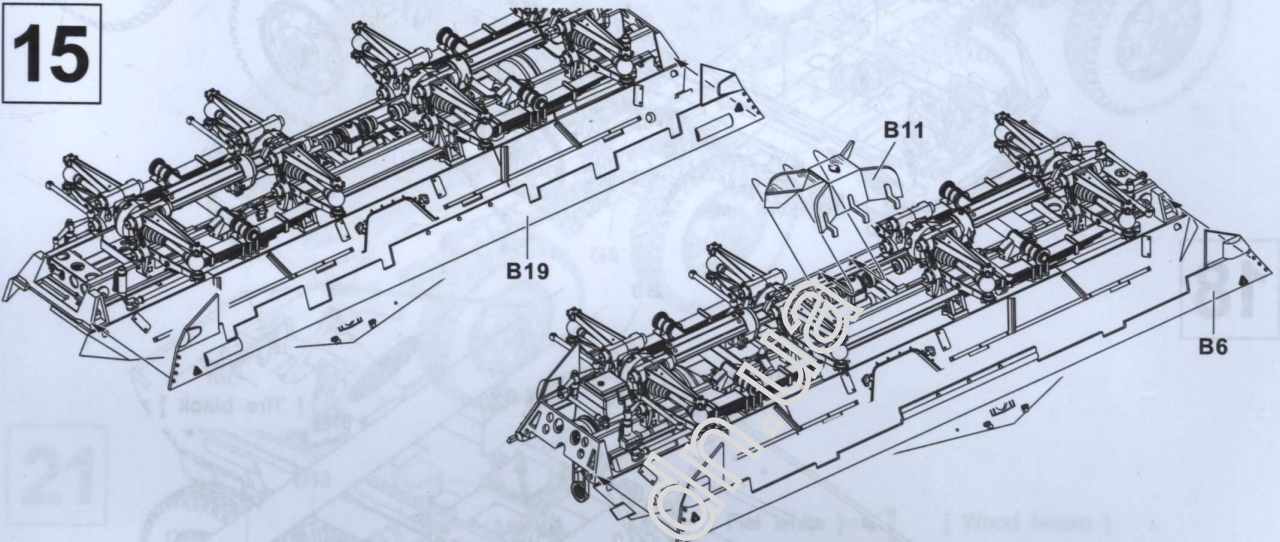

16

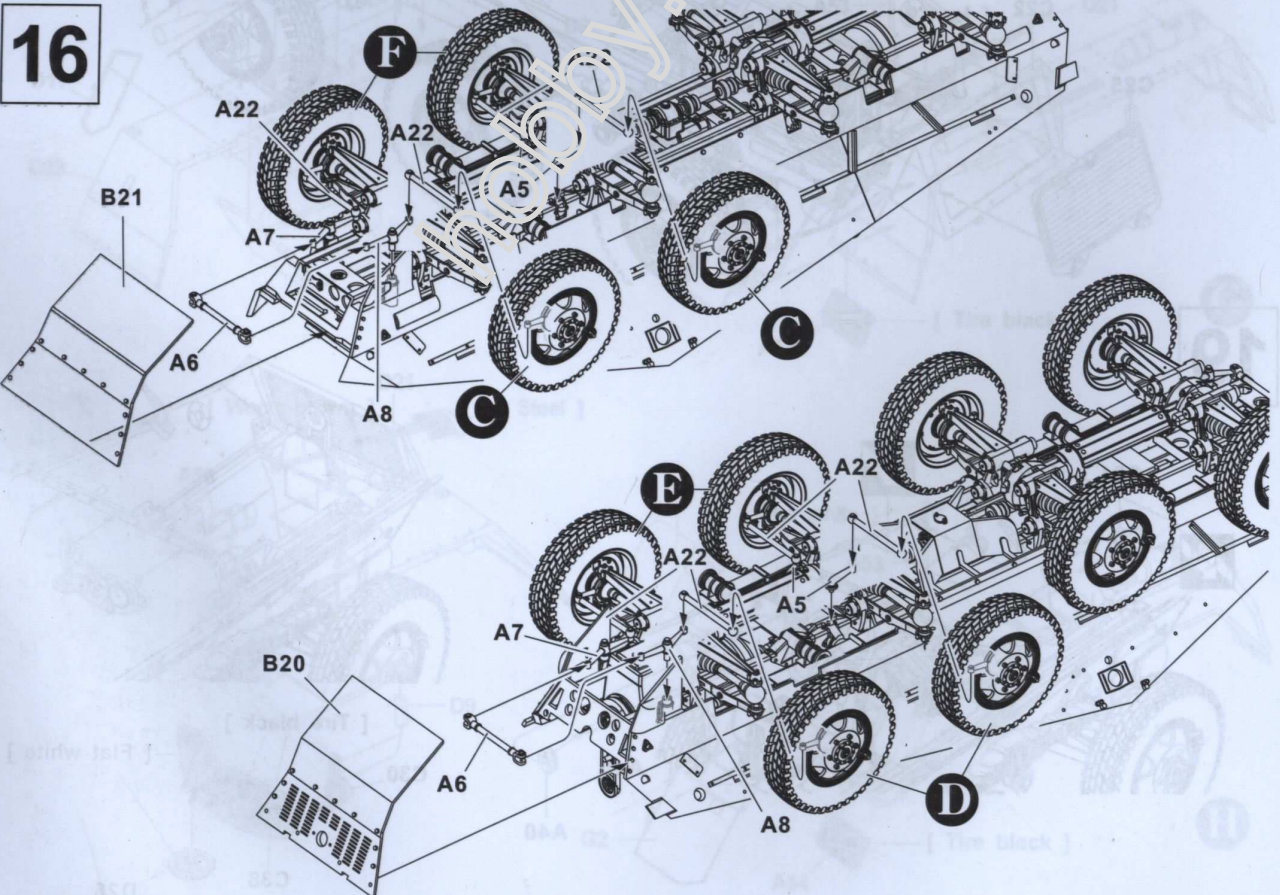

17

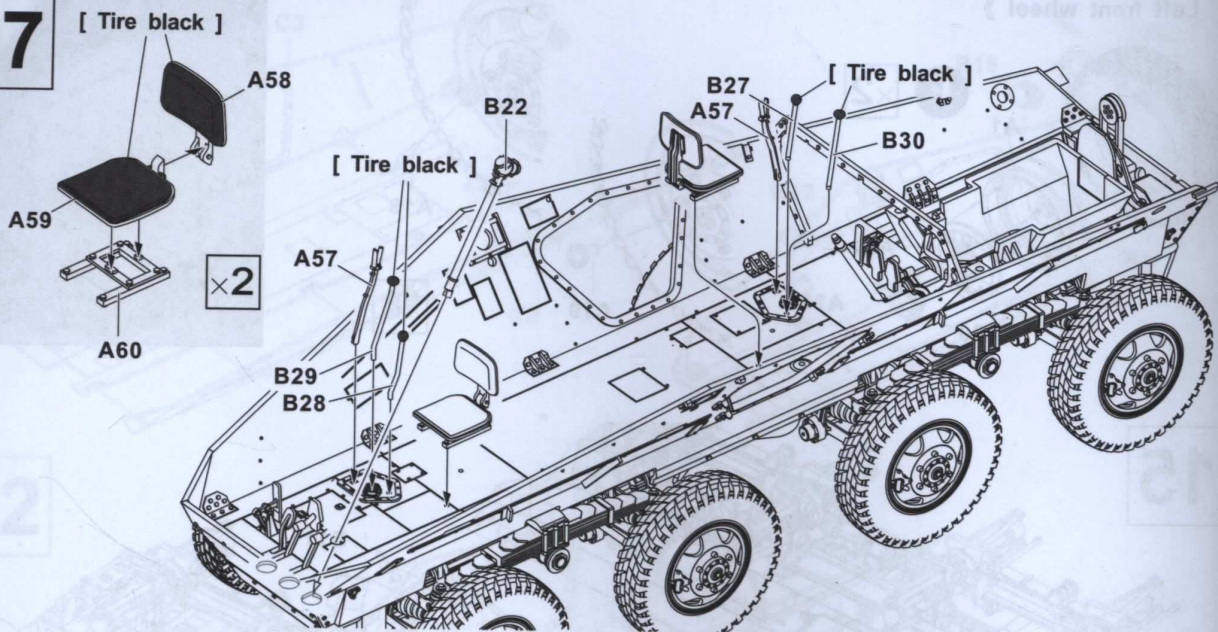

18

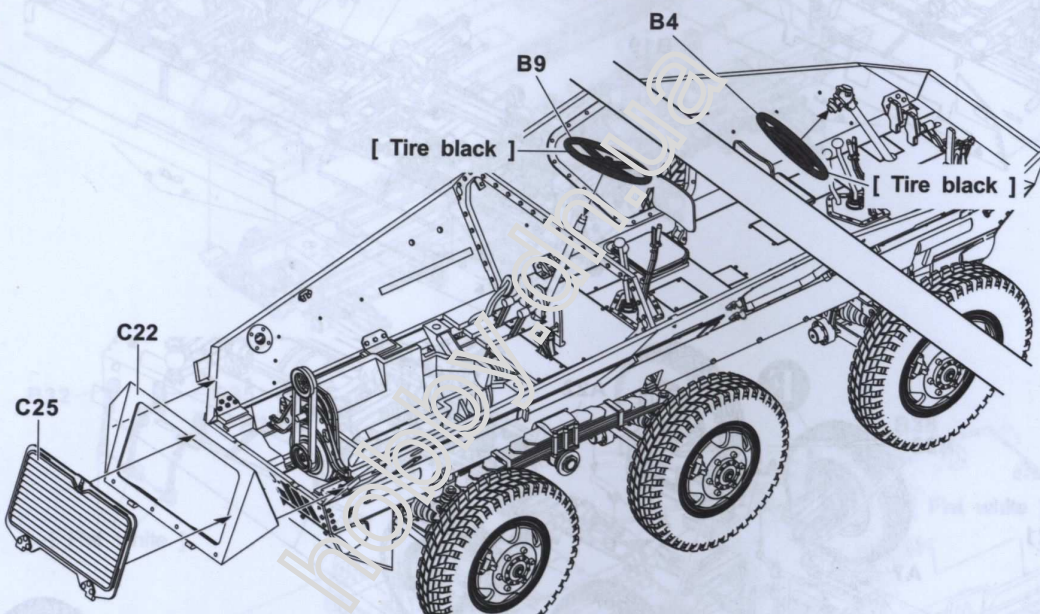

19

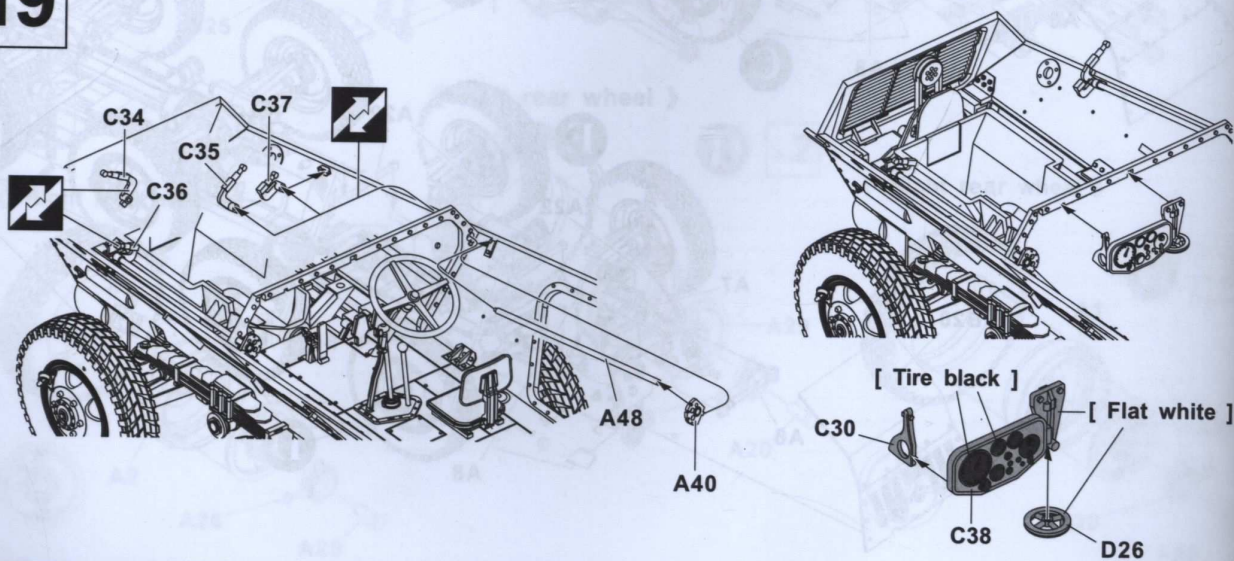

20

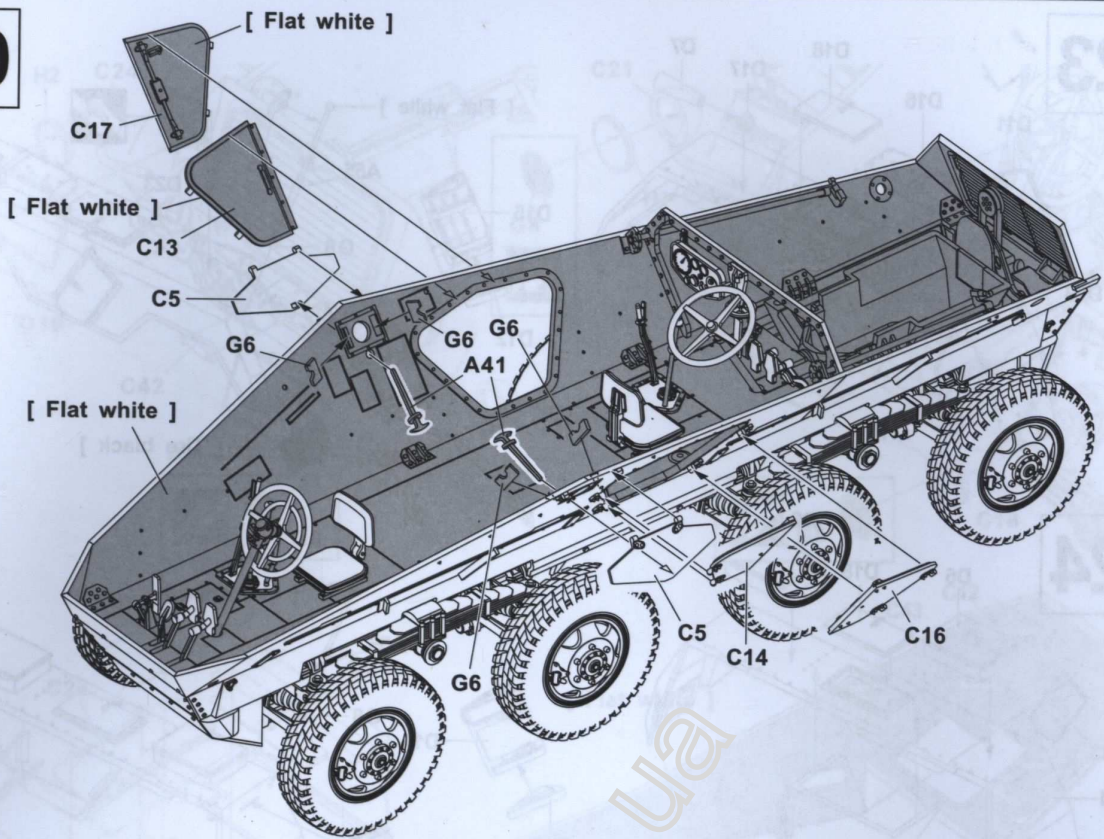

21

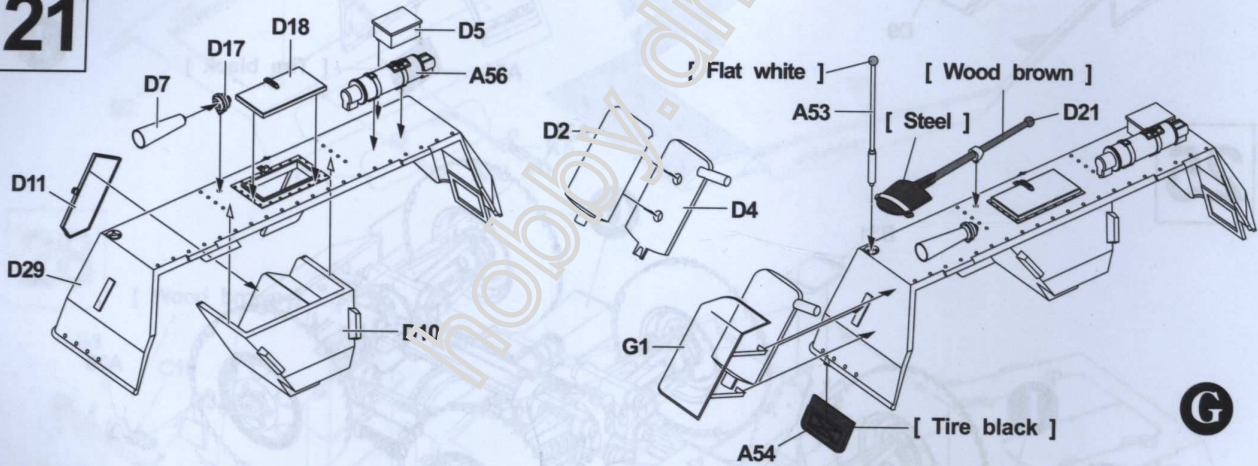

22

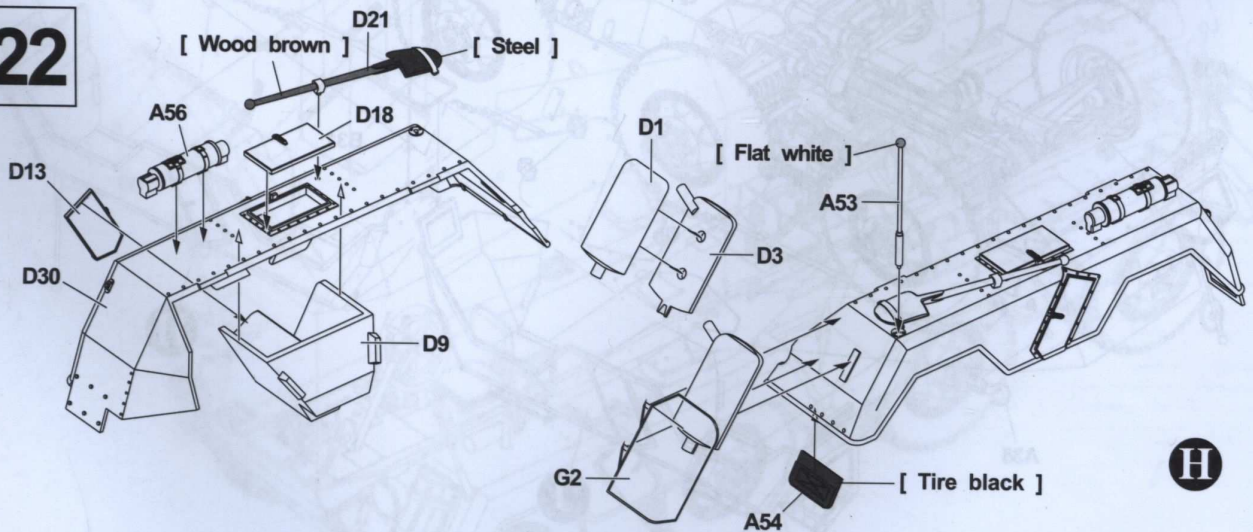

23

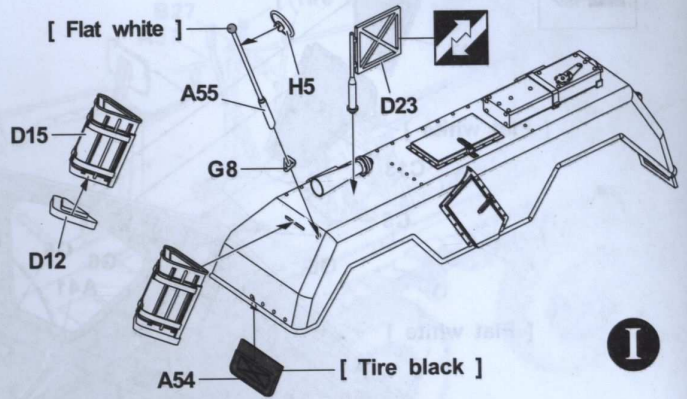
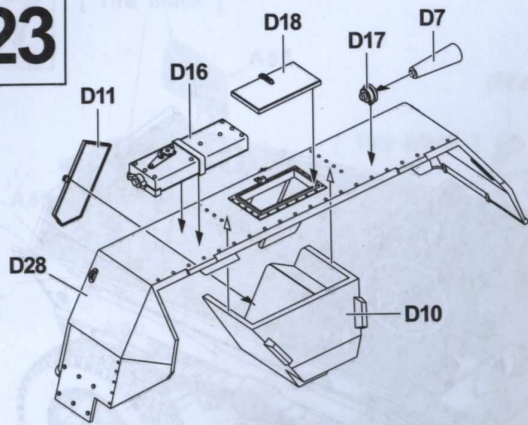

24

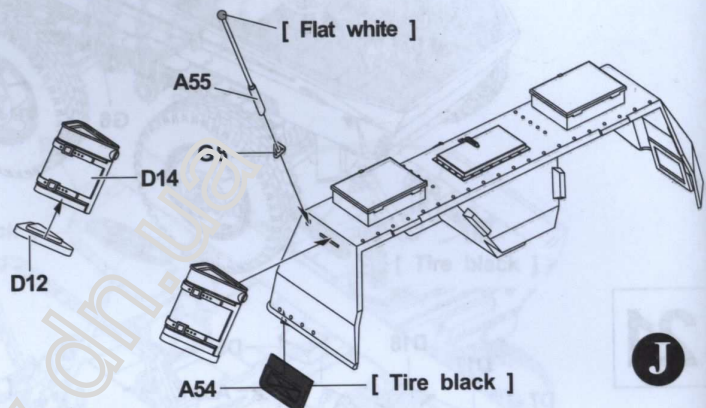
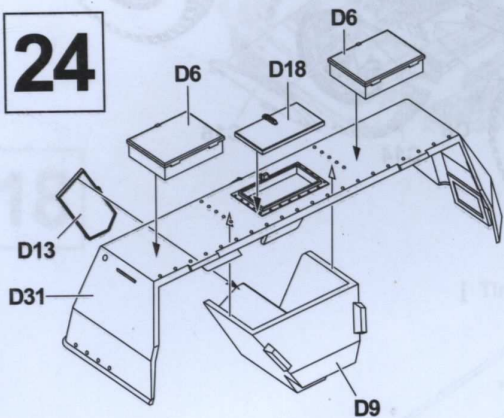

25

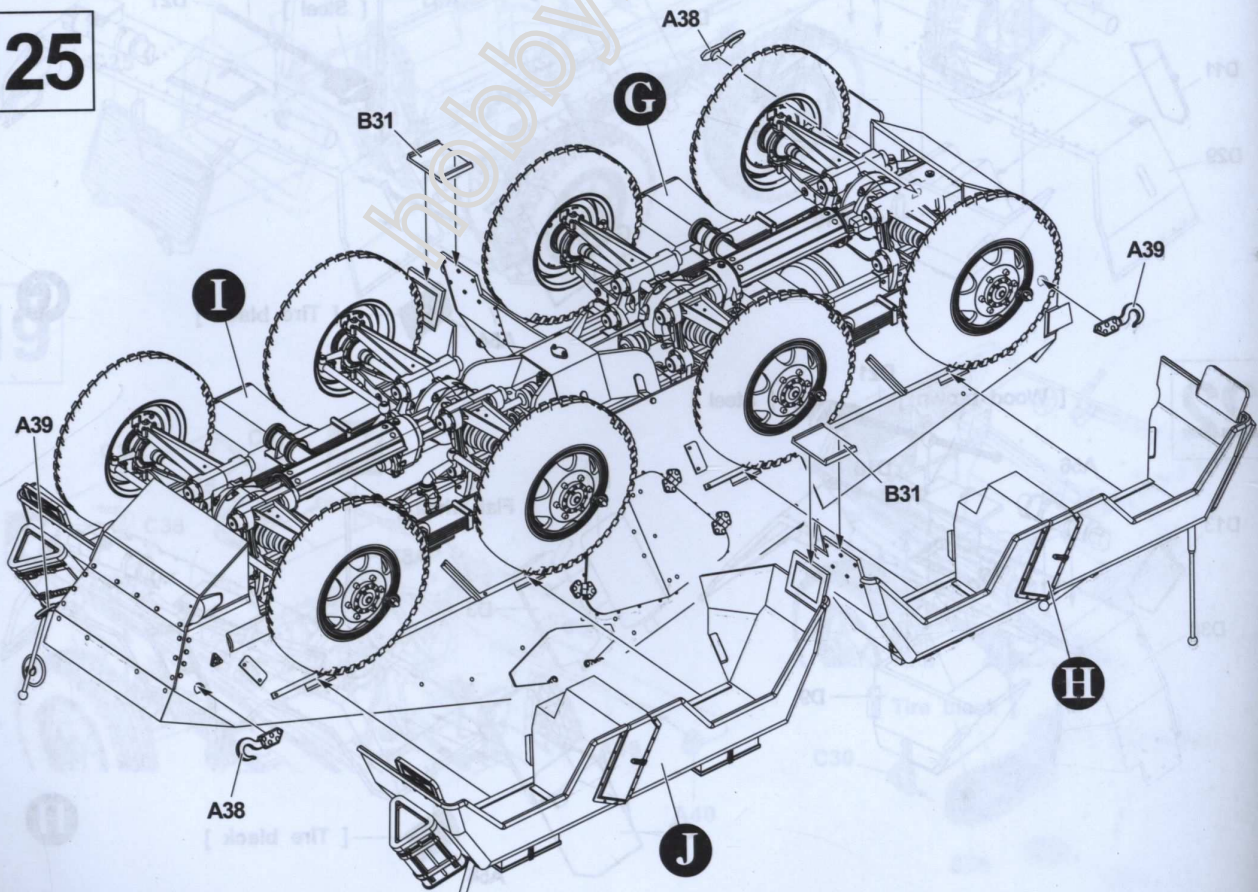

26

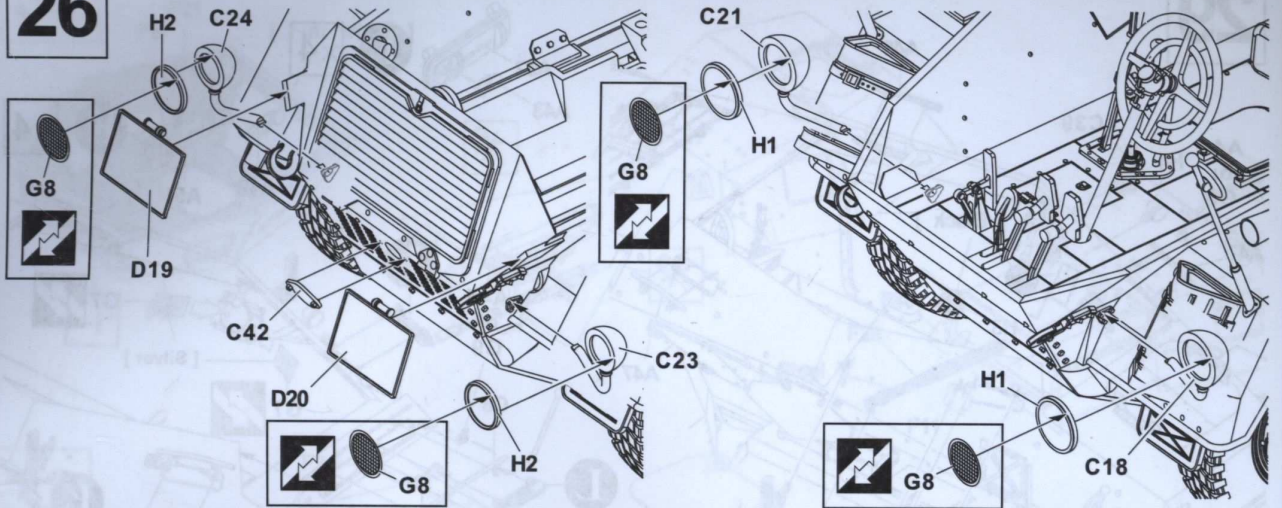

27

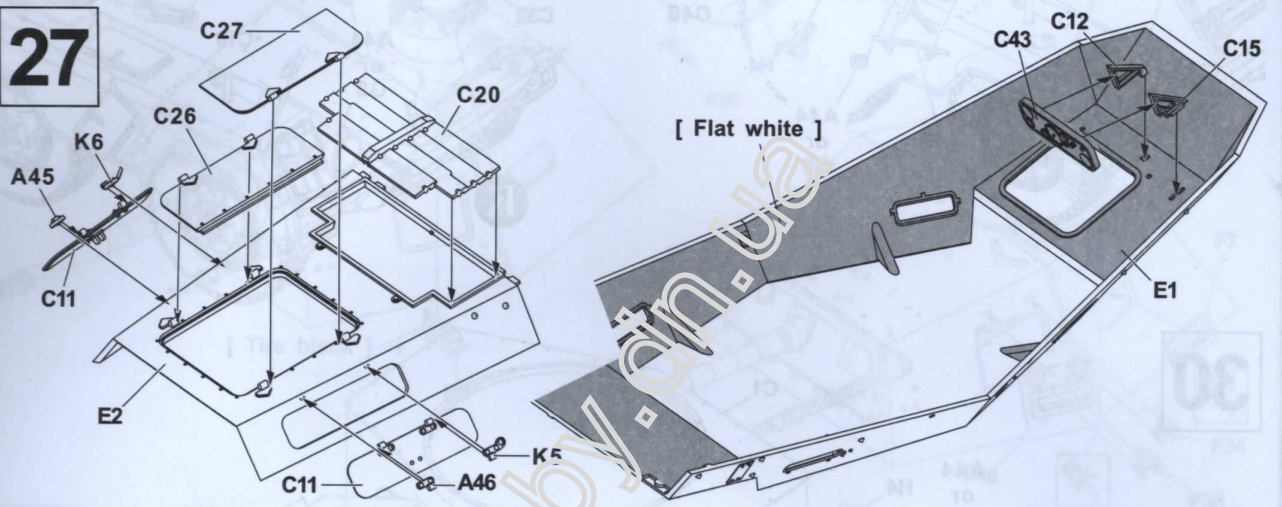

28

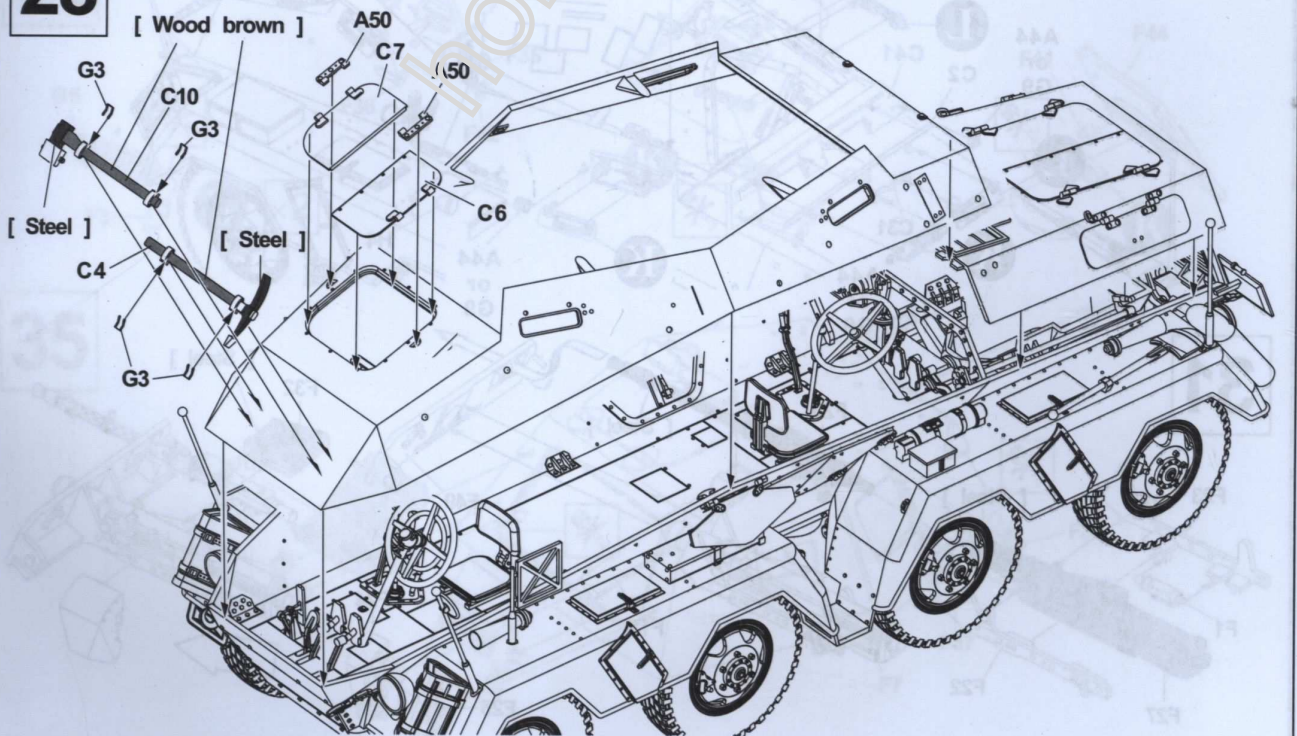

29

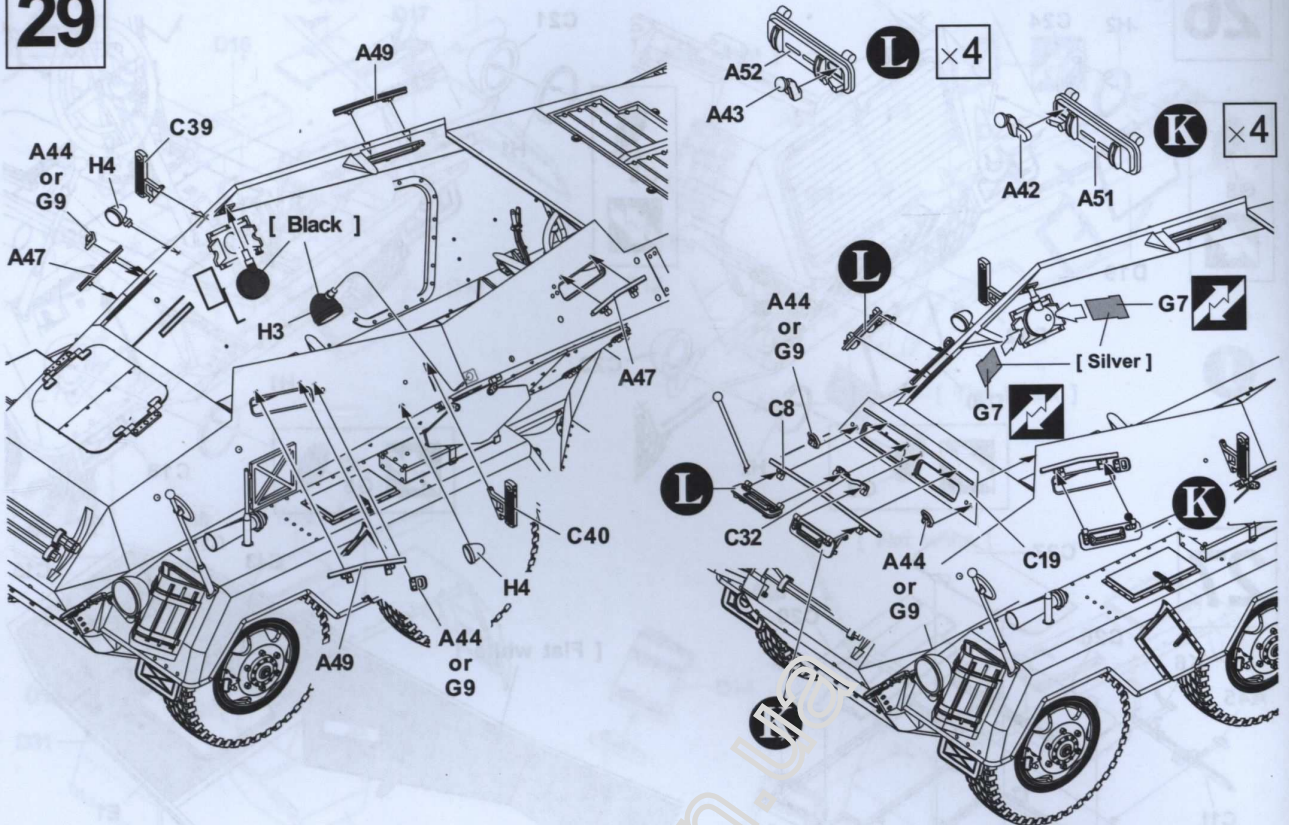

30

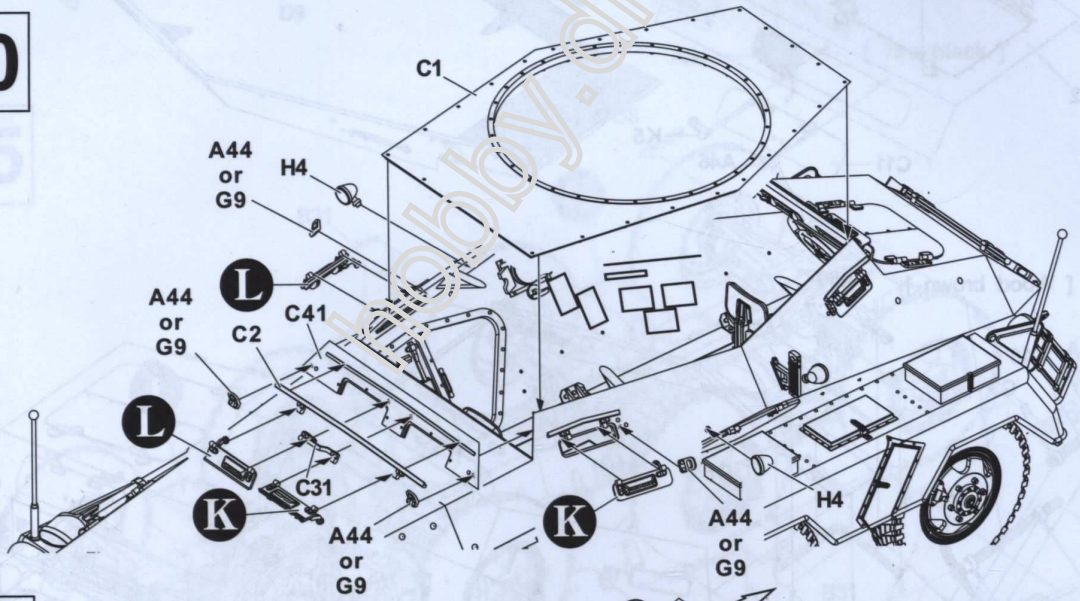

31

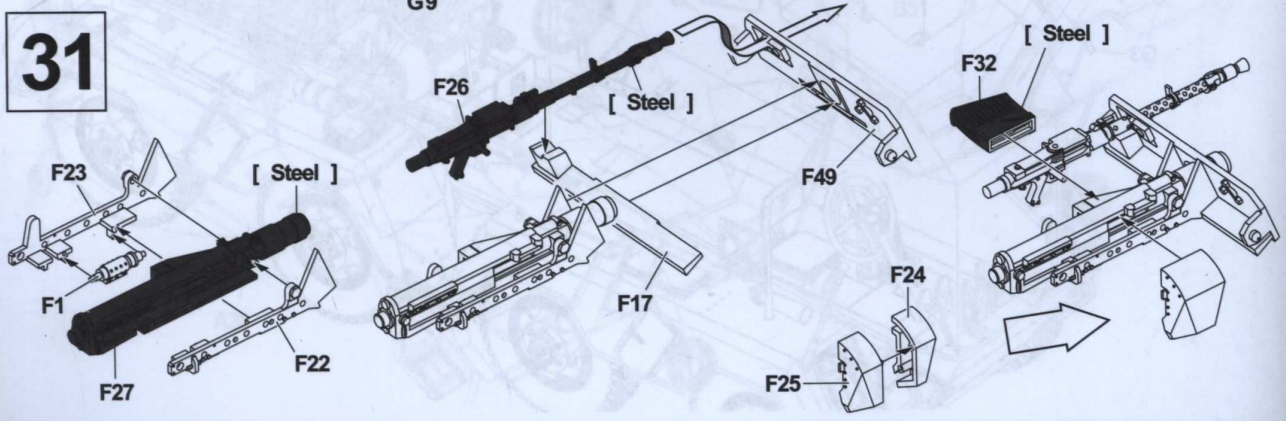

32

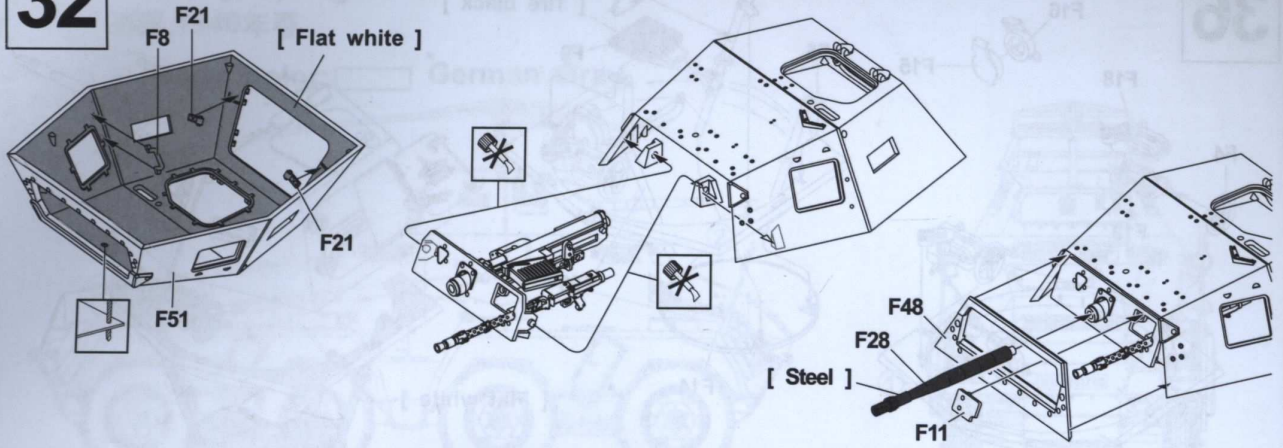

33

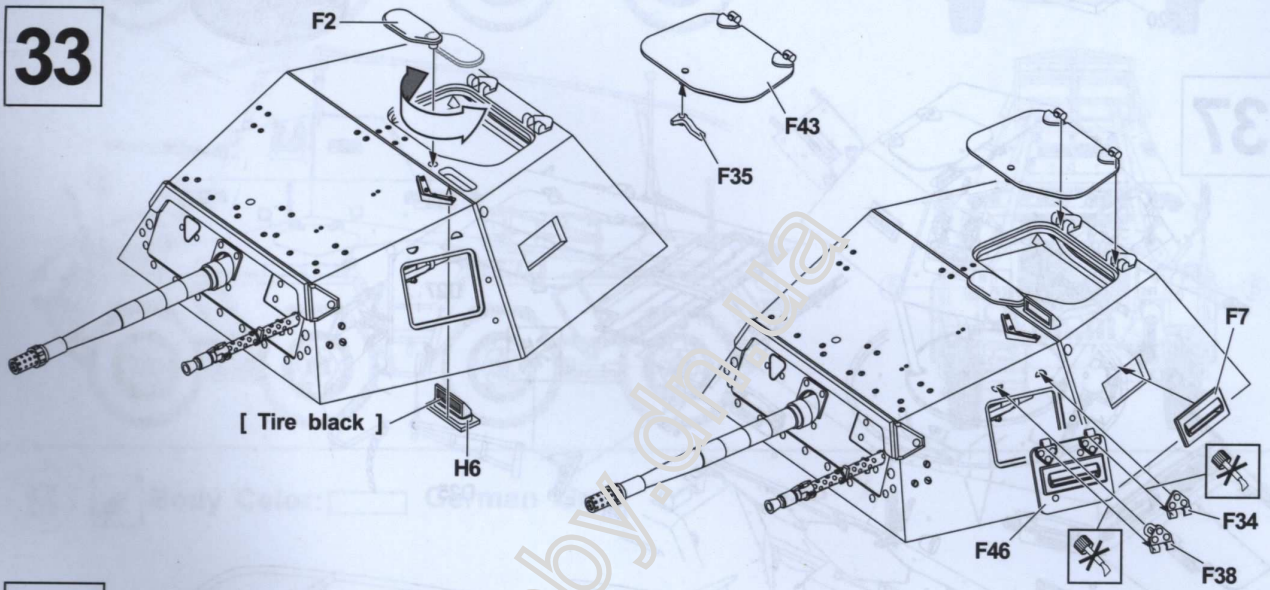

34

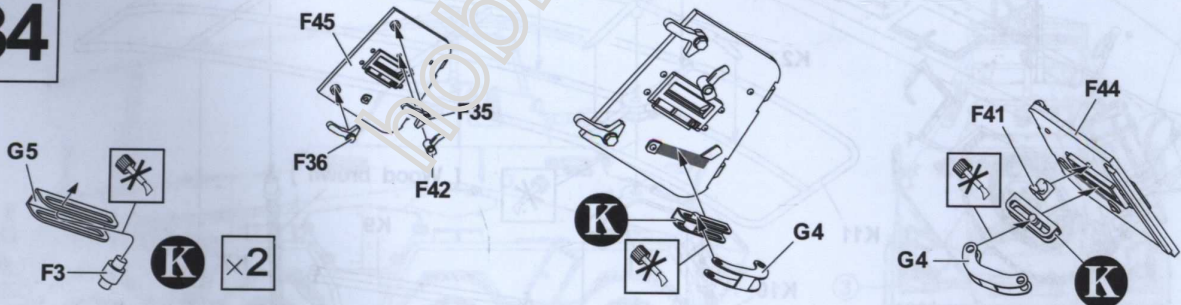

35

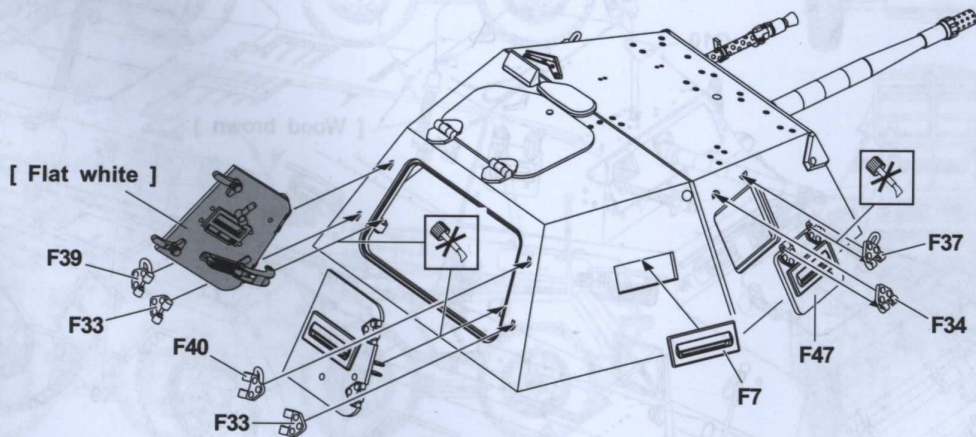

36

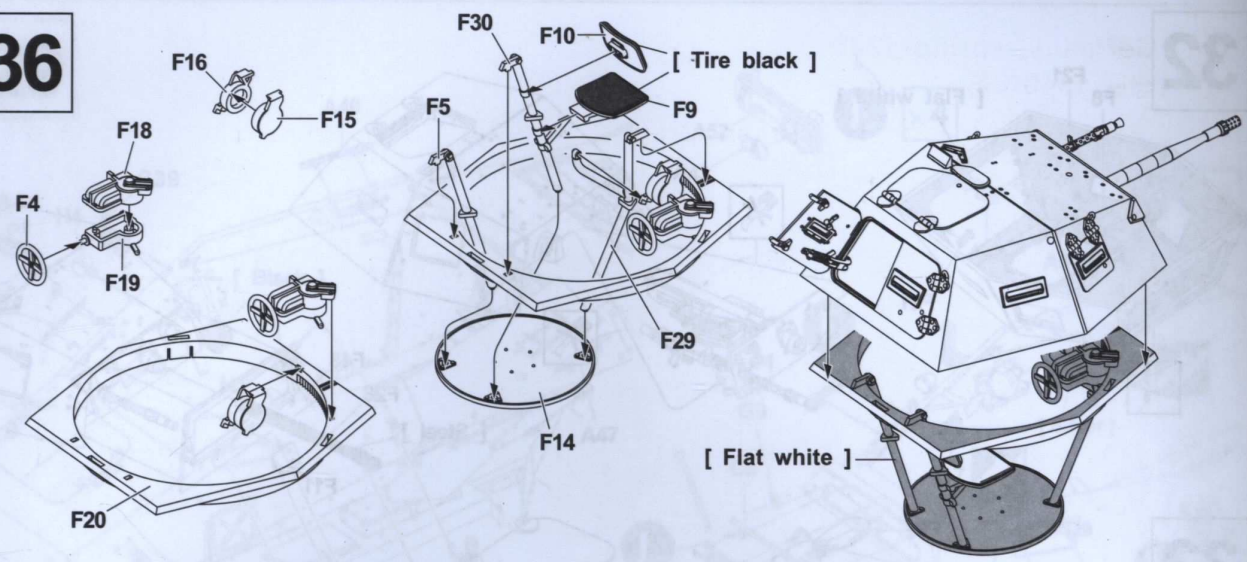

37

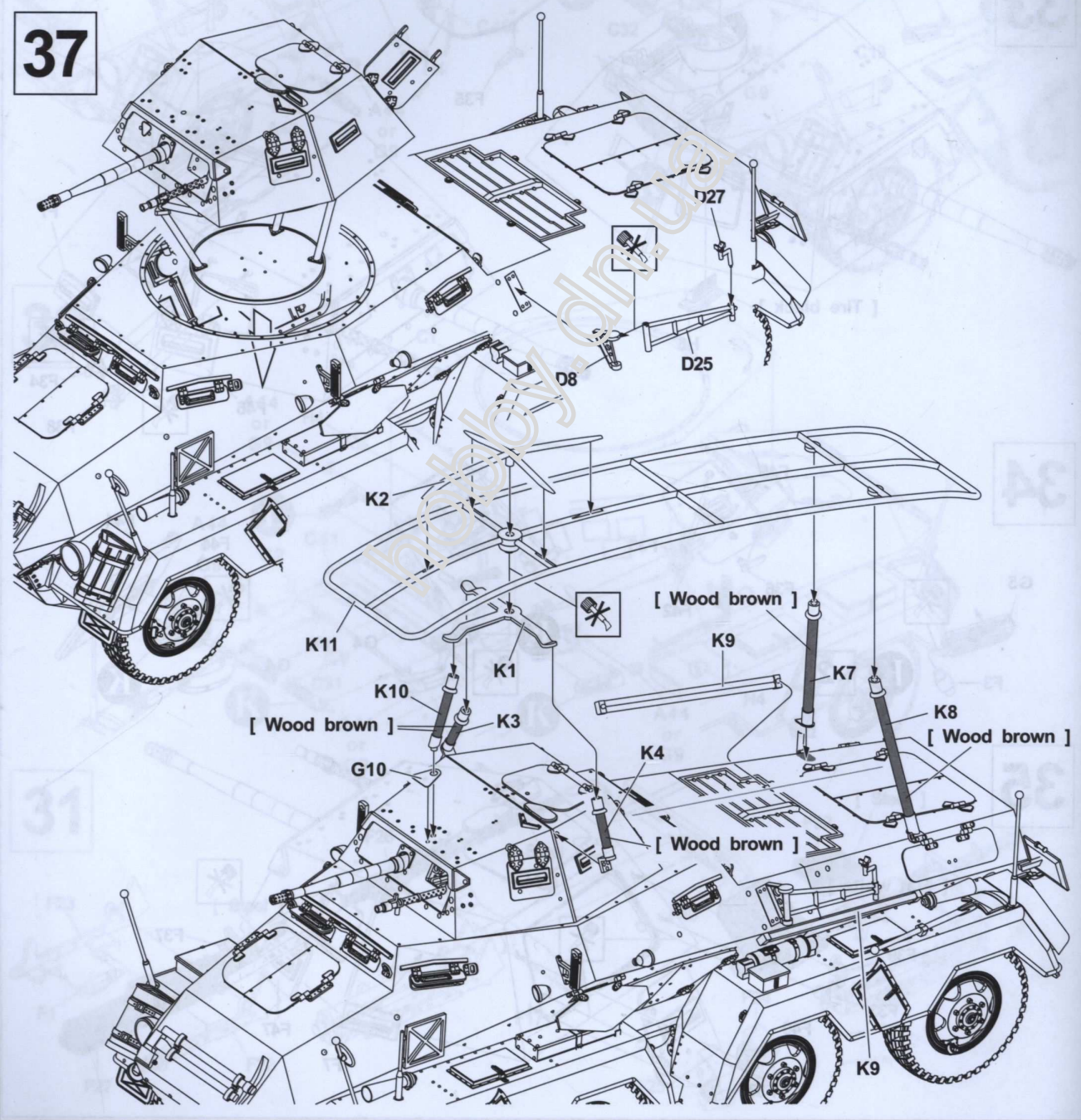

A Germany, spring 1940
德國, 1940年春

Body Color: German Gray

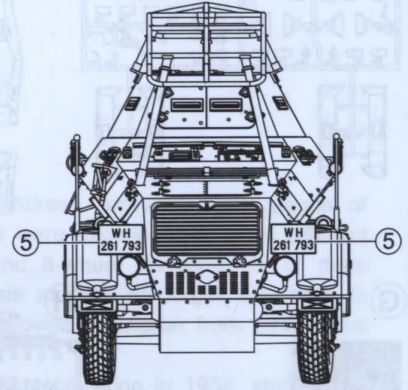
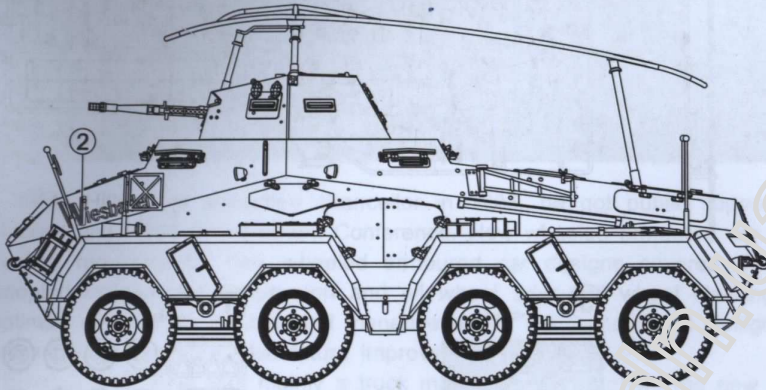
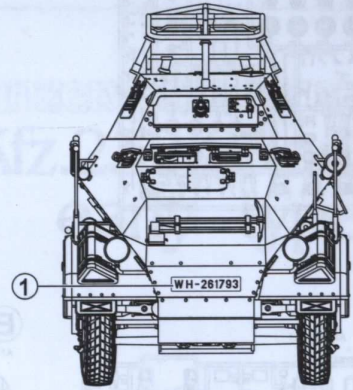
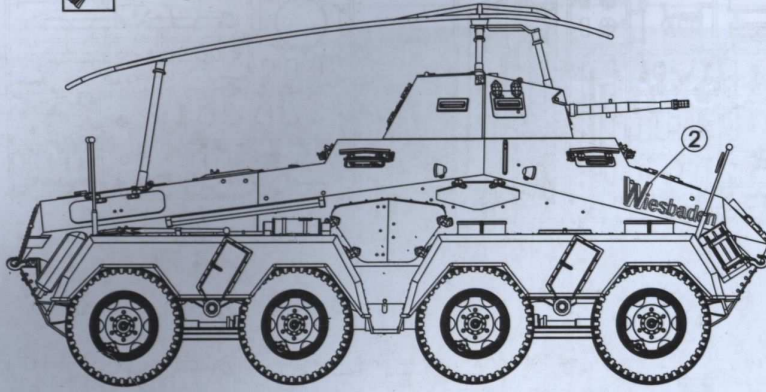

B Body Color: German Gray

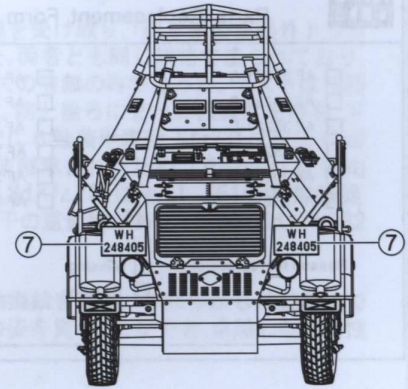
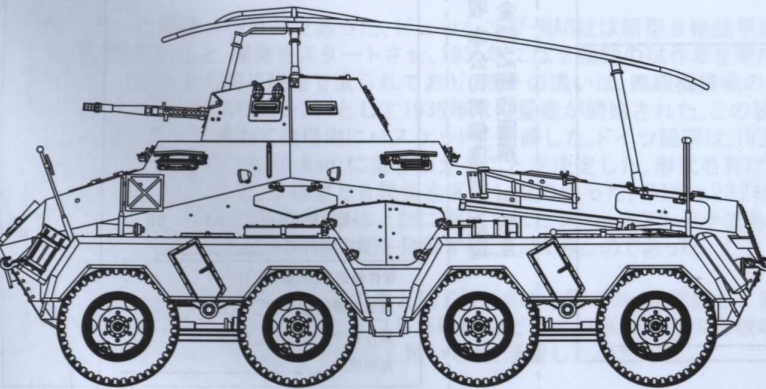
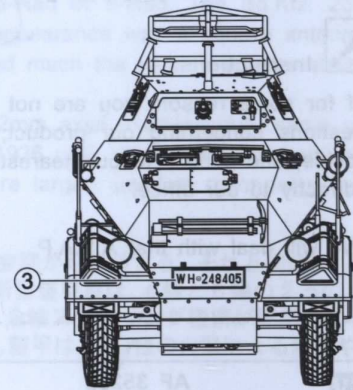
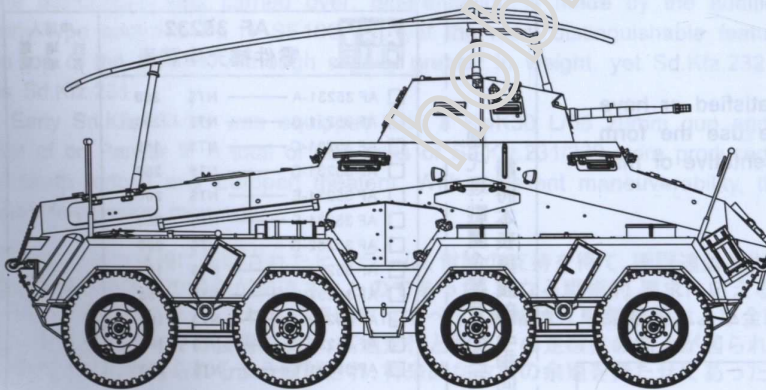

PARTS LIST 零件表

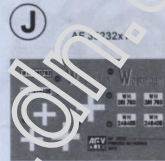
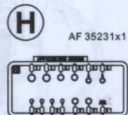
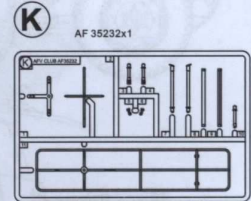
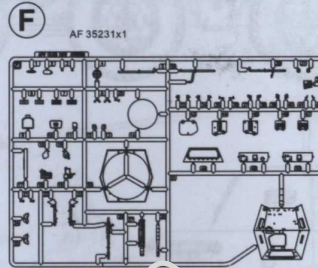
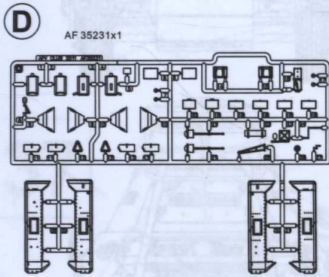
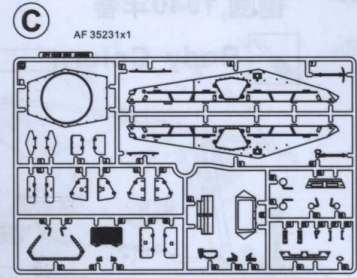
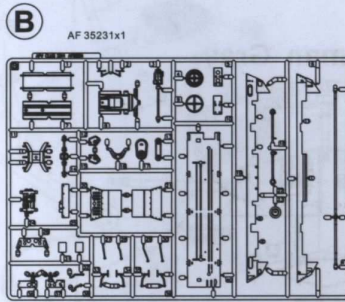
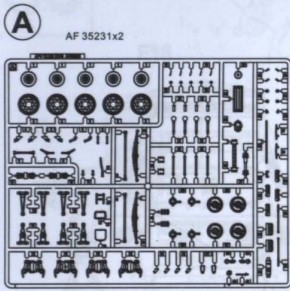

Instructions:

If for some reason, you are not fully satisfied or have questions concerning our product; Please use the form provide, and send it to our nearest representative or mail it directly to our office.

We will deal with that A.S.A.P.



AF 35232 Parts Replacement Form

- | | |
|-------------------------------------|-------------------------------------|
| <input type="checkbox"/> AF 35231-A | <input type="checkbox"/> AF 35232-G |
| <input type="checkbox"/> AF 35231-B | <input type="checkbox"/> AF 35231-H |
| <input type="checkbox"/> AF 35231-C | <input type="checkbox"/> AF 35231-I |
| <input type="checkbox"/> AF 35231-D | <input type="checkbox"/> AF 35232-J |
| <input type="checkbox"/> AF 35231-E | <input type="checkbox"/> AF 35232-K |
| <input type="checkbox"/> AF 35231-F | <input type="checkbox"/> AF 35231-T |

Reason for replacement: Missing
 Broken

Signature: _____

限臺灣地區使用 For Taiwanese use only!



AF 35232 零件補充申請表

申請人
姓 地 電
名 址 話

- | | |
|-------------------------------------|----------|
| <input type="checkbox"/> AF 35231-A | NT\$ 300 |
| <input type="checkbox"/> AF 35231-B | NT\$ 200 |
| <input type="checkbox"/> AF 35231-C | NT\$ 180 |
| <input type="checkbox"/> AF 35231-D | NT\$ 250 |
| <input type="checkbox"/> AF 35231-E | NT\$ 200 |
| <input type="checkbox"/> AF 35231-F | NT\$ 200 |
| <input type="checkbox"/> AF 35232-G | NT\$ 200 |
| <input type="checkbox"/> AF 35231-H | NT\$ 100 |
| <input type="checkbox"/> AF 35231-I | NT\$ 150 |
| <input type="checkbox"/> AF 35232-J | NT\$ 160 |
| <input type="checkbox"/> AF 35232-K | NT\$ 180 |
| <input type="checkbox"/> AF 35231-T | NT\$ 250 |

+郵寄費 _____ NT\$ 80
(請填)總計NT\$ _____

零件補充原因:(請於 打)

原包裝即 遺失或 毀損,
製作途中 遺失或 毀損,
其他原因 _____

總代理戰鷹企業有限公司收本公司將儘速為您處理。
請將本表與該部品相同金額之郵政匯票一同寄至。