



1:48 Bedford MWD

A03313 SCALE MODEL CONSTRUCTION KIT | Width: 41mm Length: 89mm | Two Decal Schemes Included | Two Build Options Included

GB The Bedford MW series was the smallest of the wartime Bedford trucks and many thousands were produced throughout the Second World War. Early models earned the nickname the 'Pneumonia Wagon' due to their small aeroscreens and open cabs. While driving the wind would scythe through them and freeze both crew and occupants. These early models helped transport the BEF (British Expeditionary Force) across France in 1940 and by the end of the summer some had found their way onto airbases to assist with

the Battle of Britain, while others did sterling work in the Middle East, against Rommel's Afrika Korps in the desert. By the middle of the war the MWD had been updated, with enclosed cabs and better weather protection for the crew. These variants were very useful on RAF bases, helping to transport crews and material to waiting aircraft. The Bedford MWD was another unsung hero of the Second World War and its contribution to motorising the logistics of the British armed forces was of vital importance.

FR Plusieurs milliers de camions de la série Bedford MW, les plus petits des véhicules Bedford, furent construits tout au long de la Deuxième Guerre mondiale. Les premiers exemplaires furent surnommés pneumonia wagons (wagons pour attraper une pneumonie) à cause de la cabine ouverte et du petit saute-vent. Pendant la conduite, le vent gelait les équipages et les occupants. En 1940, ces premiers modèles aidèrent au transport du Corps expéditionnaire britannique (BEF) à travers la France. À la fin de l'été, quelques-uns se trouvèrent sur les bases aériennes pour participer à la bataille

d'Angleterre alors que d'autres rendirent un service exceptionnel dans le désert du Moyen-Orient contre l'Afrika Korps du général Rommel. Au milieu de la guerre, le MWD avait été mis à jour et était doté d'une cabine fermée et d'une meilleure protection contre les intempéries pour le personnel. Ces variantes s'avèrent être très utiles sur les bases de la RAF, aidant à transporter les équipages et le matériel aux avions en attente. Le Bedford MWD était un héros méconnu de la Deuxième Guerre mondiale : sa contribution à la motorisation de la logistique des forces armées britanniques était d'une importance cruciale.

DE Die Fahrzeuge der Reihe Bedford MW waren zwar die kleinsten der im Zweiten Weltkrieg eingesetzten Bedford Lkws, wurden aber in viele Tausende zählenden Stückzahlen während des gesamten Kriegsverlaufs hergestellt. Ihre klein bemessene Windschutzscheibe und ihr offenes Führerhaus trug den frühen Versionen bald den Spitznamen „Pneumonia Wagon“ (Lungenentzündungswagen) ein. Die Fahrer und Beifahrer mussten nämlich bei kaltem Zugwind oft ganz jämmerlich frieren. Mit diesen frühen Modellen waren viele Soldaten des britischen Expeditionskorps (BEF) durch Frankreich transportiert worden. Bis Ende des Sommers 1940 waren viele auch bei Luftwaffenstützpunkten der RAF angekommen. Dort wurden sie zur Unterstützung der Luftschlacht um England eingesetzt,

während andere sich im Nahen Osten im Wüstenkampf gegen Rommels Afrika-Korps bewährten. Um die Kriegsmitte war dann die verbesserte Version MWD verfügbar gemacht worden, die nun mit abgeschlossenen Führerhäusern und besserem Wetterschutz für die Mannschaften ausgerüstet worden war. Diese Varianten erwiesen sich auf Stützpunkten der RAF als besonders nützlich, wo sie Kriegsmaterial und Mannschaften zu wartenden Flugzeugen beförderten. Der Bedford MWD war sicherlich einer jener unbesungenen Helden des Zweiten Weltkriegs, der für den motorisierten Nachschub der britischen Streitkräfte einen unverzichtbaren Beitrag leistete.

ES El Bedford serie MW fue el más pequeño de los camiones Bedford durante la guerra, con muchos miles de unidades producidas durante la Segunda Guerra Mundial. Los primeros modelos se ganaron el sobrenombre de 'camión pulmonía', por su pequeño parabrisas y cabina abierta. Al conducir, el viento entraba en la cabina y congelaba tanto a la tripulación como a los ocupantes. Estos primeros modelos ayudaron a transportar la Fuerza Expedicionaria Británica (BEF) hasta Francia en 1940 y, a finales de ese verano, habían llegado a las bases aéreas para realizar su aportación a la Batalla

de Inglaterra, mientras que otras unidades realizaron un brillante trabajo en los desiertos de Oriente Medio, contra el Afrika Korps de Rommel. Durante la guerra, el MWD había sido mejorado con cabina cerrada y mejor protección contra la climatología adversa para la tripulación. Estas variantes resultaron muy útiles en las bases de la RAF y ayudaron a transportar tripulaciones y material hasta los aviones. El Bedford MWD fue otro de los héroes de la Segunda Guerra Mundial cuya contribución para motorizar la logística de las fuerzas armadas británicas fue vital, pero nunca suficientemente valorada.

SE Bedford MW-serien, som producerades i tusental under det andra världskriget, var det minsta av krigstidens Bedford-fordon. Tidiga modeller gavs öknamnet "Pneumonia Wagon" (lunginflammationsvagn) på grund av deras små vindrutor och öppna förarplatser. Under transporter drabbades både föraren och passagerarna av de kalla vindar som drog genom fordonet. Dessa tidiga modeller transporterade BEF (British Expeditionary Force) genom Frankrike 1940, och i slutet på sommaren stationerades vissa fordon på flygbaser under Slaget om Storbritannien. Andra användes med framgång

i Mellanöstern och i ökenstriderna mot Rommels Afrika Korps. I krigets mellanskede hade MWD försetts med slutna förarplatser och mer effektiva vädskydd. Dessa varianter var mycket användbara för transporter av besättning och material till väntande flygplan på RAF:s baser. Bedford MWD utgör dock ett annat underskattat bidrag till det andra världskrigets ansträngningar trots att dess insatser vid transporter av förnödenheter till de brittiska styrkorna var betydande.

Airfix would like to thank John Rippingham for his assistance with this project.

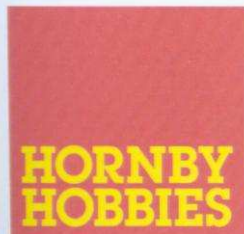

FOR BEST RESULTS:

Surfaces to be painted should be clean – before parts are removed from the sprue, wash in warm, soapy water, rinse and dry thoroughly. Stir paints thoroughly before use.

PLEASE NOTE:

Some parts in the kit may not be required to build the model specified.



ASSEMBLY INSTRUCTIONS

GB Study drawings and practice assembly before cementing parts together. Carefully scrape plating and paint from cementing surfaces. All parts are numbered. Paint small parts before assembly. To apply decals cut sheet as required, dip in warm water for a few seconds, slide off backing into position shown. Use in conjunction with box artwork. Not appropriate for children under 36 months of age, due to the presence of small detachable parts.

FR Étudier attentivement les dessins et simuler l'assemblage avant de coller les pièces. Gratter soigneusement tout revêtement ou peinture sur les surfaces à coller avant collage. Toutes les pièces sont numérotées. Peindre les petites pièces avant l'assemblage. Pour coller les décalques, découper le motif, le plonger quelques secondes dans de l'eau chaude puis le poser à l'endroit indiqué en décollant le support papier. Utiliser en même temps les illustrations sur la boîte. Ne convient pas à un enfant de moins de 36 mois - présence de petits éléments détachables.

DE Vor Verwendung des Klebers Zeichnungen studieren und Zusammenbau üben. Farbe und Plattierung vorsichtig von den Klebeflächen abkratzen. Alle Teile sind nummeriert. Vor Zusammenbau kleine Teile anmalen. Um die Abziehbilder aufzukleben, diese ausschneiden, kurz in warmes Wasser tauchen, dann abziehen und wie abgebildet aufkleben. In Verbindung mit Abbildungen auf Schachtel verwenden. Ungeeignet für Kinder unter 36 Monaten. Kleine Teilchen vorhanden die sich lösen können.

ES Estudiar los dibujos y practicar el montaje antes de pegar las piezas. Raspar cuidadosamente el plateado y la pintura en las superficies de contacto antes de pegar las piezas. Todas las piezas están numeradas. Es conveniente pintar las piezas pequeñas antes de su montaje. Para aplicar las calcomanías, cortar la hoja, sumergir en agua tibia durante unos segundos y deslizarlas en la posición debida. Ver ilustraciones en la caja. No conviene a un niño menor de 36 meses, contiene pequeñas piezas que pueden soltarse.

SE Studera bilderna noggrant och sätt ihop delarna innan du limmar ihop dem. Skrapa noggrant bort förtromning och färg från limmade delar. Alla delarna är nummerade. Mala smadelarna före ihopsättning. Fastsättning av dekaler, klipp arket. Doppa i varmt vatten några sekunder, lat baksidan glida på plats som bilden visar. Används i samband med kartongens handlitografi. Rekommenderas ej för barn under 3 år. Innehåller löstagbara smadelar.

IT Studiare i disegni e praticare il montaggio prima di unire insieme i pezzi con l'adesivo. Raschiare attentamente le tracce di smalto e cromatura dalle superfici da unire con adesivo. Tutti i pezzi sono numerati. Colorare i pezzi di piccole dimensioni prima di montarli. Per applicare le decalcomanie, tagliare il foglio secondo il caso, immergere in acqua calda per alcuni secondi, quindi sfilare la decalcomania dalla carta di supporto e piazzarla nella posizione indicata. Usare in congiunzione con l'illustrazione sulla scatola. Non adatto ad un bambino di età inferiore ai 36 mesi dovuto alla presenza di piccoli elementi staccabili.

NL Tekeningen bestuderen en delen in elkaar zetten alvorens deze te lijmen. Metaalcoating en lak voorzichtig van lijmvlakken af schrapen. Alle delen zijn genummerd. Kleine delen vóór montage verven. Voor aanbrengen van stickers, gewenste stickers uit vel knippen, een paar seconden in warm water dompelen en dan van schutblad af op afgebeelde plaats schuiven. Hierbij afbeelding op doos raadplegen. Niet geschikt voor kinderen onder 3 jaar, omdat kleine deeltjes gemakkelijk kunnen losraken.

DK Tegningerne bør studeres, og man bør øve sig i monteringen, før delene limes sammen. Pladestykker og maling skal omhyggeligt fjernes fra kloebeoverfladerne. Alle dele er nummererede. Små dele skal males før monteringen. Overføringsbillederne anvendes ved at tilklippe arket efter behov. Og dyppe det i varmt vand i nogle få sekunder. Underlaget glides af og anbringes i den viste position. Påføres ifølge brugsanvisningerne på oesken. Ikke til børn under 3 år, forekomst af små løse elementer.

PT Estudar atentamente os desenhos e experimentar a montagem. Raspar cuidadosamente as superfícies de modo a eliminar pintura e revestimento antes de colar. Todas as peças estão numeradas. Pintar as pequenas peças antes de colar. Para aplicar as decalcomanias, cortar as folhas e mergulhar em água morna por alguns segundos, depois deslizar e aplicar no respectivo lugar, como indicado nas ilustrações na caixa. Não convém a uma criança de menos de 36 meses devido à presença de pequenos elementos destacáveis.

FI Tutustu piirroksiin ja harjoittele kokoamista ennen kuin liimaat osat yhteen. Raaputa metallipäällyste ja maali varovasti pois liimattavilta pinoilta. Kaikki osat on numeroitu. Maalaa pienet osat ennen kokoamista. Siirtokuvien kiinnittämiseksi leikkaa ne arkista tarpeen mukaan. Kasta kuva lämpimään veteen muutaman sekunnin ajaksi, anna takapuolen liukua kovalle osoitettuun kohtaan. Käytetään yhdessä latikon kuvituksen kanssa. Ei suositella alle kolmivuotiaille lapsille. Paljon irrotettavia pikkuosia.

PL Przed przystąpieniem do sklepania przestudiuj uważnie rysunki i przećwicz składanie części. Osłóżnie zeskrób ze sklepanych powierzchni powłokę i farbę. Wszystkie części są ponumerowane. Drobne części pomaluj przed ich złożeniem. Celem przeniesienia odbitki wytnij ją z arkusza, zanurz na kilka sekund w letniej wodzie i zsuń z podłoża na wymagane miejsce. Używaj w połączeniu ze wzorami na pudełku. W związku z obecnością wielu drobnych, rozbiernych części, niestosowne dla dzieci poniżej 3 lat.

GR Μελετήστε προσεκτικά τα σχέδια και συναρμολογήστε για πρώτη φορά τα κομμάτια χωρίς να τα συγκολλήσετε. Αφαιρέστε επιμελώς τη μεταλλική μπογιά και την πλαστική βαφή από τις επιφάνειες τις οποίες θα συγκολλήσετε ξύνοντάς τες προσεκτικά. Όλα τα κομμάτια είναι αριθμημένα. Χρωματίστε τα μικρά κομμάτια πριν από τη συναρμολόγηση. Για να κολλήσετε τις χαλκομανίες, κόψτε γύρω από το σχέδιο όπως απαιτείται, βυθίστε το μερικά δευτερόλεπτα σε χλιαρό νερό και μετά τοποθετήστε το στη θέση που υποδεικνύεται, αφαιρώντας τη μεμβράνη που το καλύπτει. Λάβετε υπόψη σας ταυτόχρονα την εικονογράφηση του κουτιού. Ακατάλληλο για παιδιά ηλικίας κάτω των 36 μηνών λόγω ύπαρξης μικρών κομματιών που αποσπώνται.

ASSEMBLY ICON INSTRUCTIONS

<p>Assembly phase Phase de montage Montagephase Fase de montaje Monteringsfasen Fase di montaggio Montagefase Fase de montagem Monteringsfase Kokoamisvaihe Faza składowania Φάση συναρμολόγησης</p>	<p>Cement Coller Kleben Pegar Limma Incollare Lijmen Colar Klebes Limmaa Kleić Συγκολλήστε</p>	<p>Do not cement together No pas coller Nicht kleben No pegar Limma inte Non incollare Niet lijmen Não colar Sikal ikke klebes Älä limmaa Nie kleić Μη συγκολλήσετε</p>	<p>Indicates final location Indique l'emplacement final Zeigt Endposition Indica la ubicación definitiva Sede di montaggio finale Geeft uiteindeijke locatie aan Indica localização final Osoittaa lopullisen sijainnin Oznacza miejsce docelowe Υποδεικνύει τελική τοποθεσία</p>	<p>Alternative part(s) provided Autre(s) pièce(s) fournie(s) Ersatzteil(e) mitgeliefert Se incluye(n) pieza(s) alternativa(s) Alternativ(a) del(ar) ingår Uno o più componenti alternativi forniti Alternatieve onderdelen meegeleverd Peça(s) alternativa(s) fornecida(s) Alternativ(e) del(e) medfølger Vaihtoehtoiset osat pakkauskassa Dostępne części zamiennie Παρέχονται εναλλακτικά κομμάτια</p>	<p>Repeat this operation Répéter l'opération Vorgang wiederholen Repètir la operación Upprepa åtgärden Ripetere l'operazione De verrichting herhalen Repètir a operação Manøveren gentages Toista toimenpidettä Powtórzyc operację Επανάλαβε τη διαδικασία</p>	
<p>Decals Dècalcomanias Abziehbild Calcomanias Dekaler Decalcomanie Stickers Decalcomania Billedoverføring Siirtokuvat Kalkomanias Χαλκομανίες</p>	<p>Crystal part Pièce cristal Kristallteil Pieza de cristal Kristalideli Pezzo cristallo Kristallen onderdeel Peça de cristal Kristalstykke Kristalliosa Część kryształowa Κομμάτι κρυστάλλου</p>	<p>Weight Lester Beschweren Lastrar Beiaста Aplicare un peso Verzwaren Lastrar Påfør vægt Aseta vastapaino Obciążyc balastem Επιθέστε βάρος</p>	<p>Remove by filing Enlever avec une lime Abfeilen Elinar con lima Ta bort genom att fila Rimuovere con la lima Verwijderen door afvijlen Removeo limando Fjern ved at file væk Poista viilaamalla Usunaj przy użyciu pilnika □ □ □ αφαιρέστε λιμόνιες με λιμά</p>	<p>Drill or pierce Perçer Durchbohren Perforar Borra Trapanare o forare Boren of doorboren Furar Gennembor Poraa tai puhkaise Wymiercić lub przedziurawić Τρυπήστε</p>	<p>Cut Découper Schneiden Cortar Skär Tagliare Snijden Cortar Skær Leikkaa Przećiąć Κόψτε</p>	<p>Humbrol paint number No peinture Humbrol Humbrol-Farbnummer No de pintura Humbrol Humbrol färg nummer No vernice Humbrol Humbrol verfnummer No de pintura Humbrol Humbrol malingnummer Humbrol-maali numero Nr farby Humbrol Νόμερο χρώματος Humbrol</p>

A

Early Version
Build Steps 1 to 40

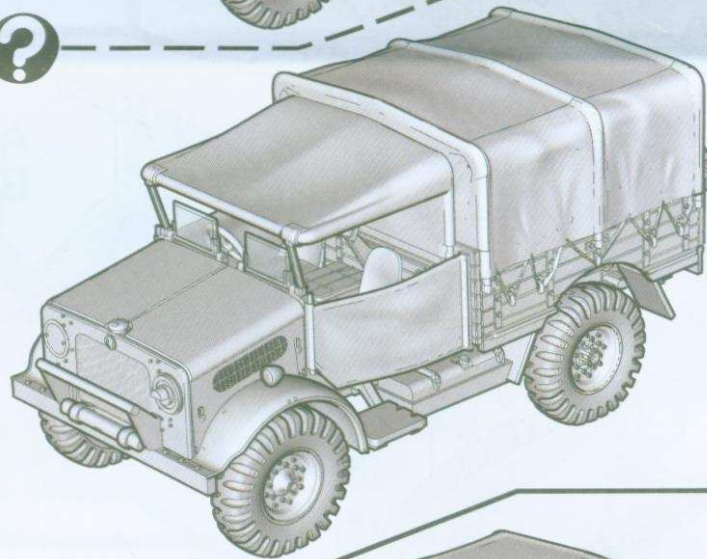
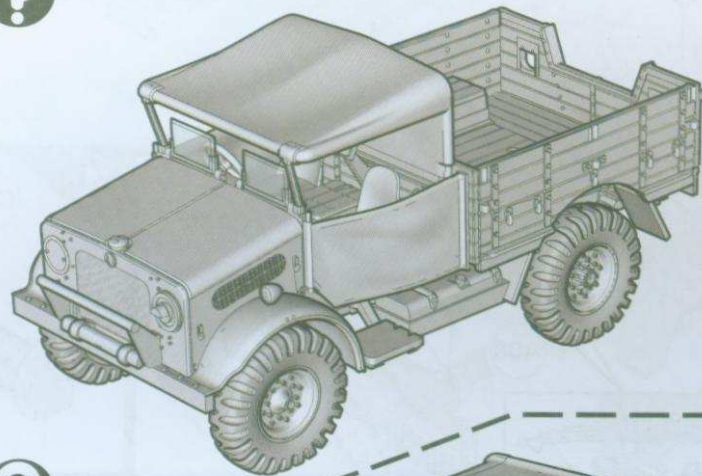
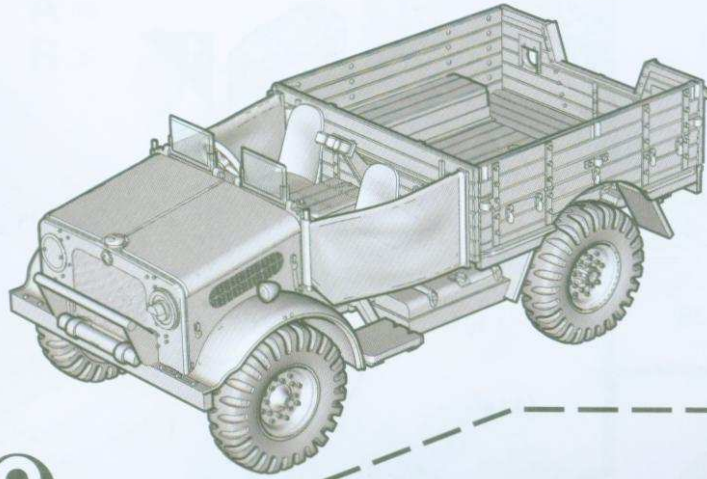

B

Late Version
Build Steps 1 to 18
Then Steps 41 to 63

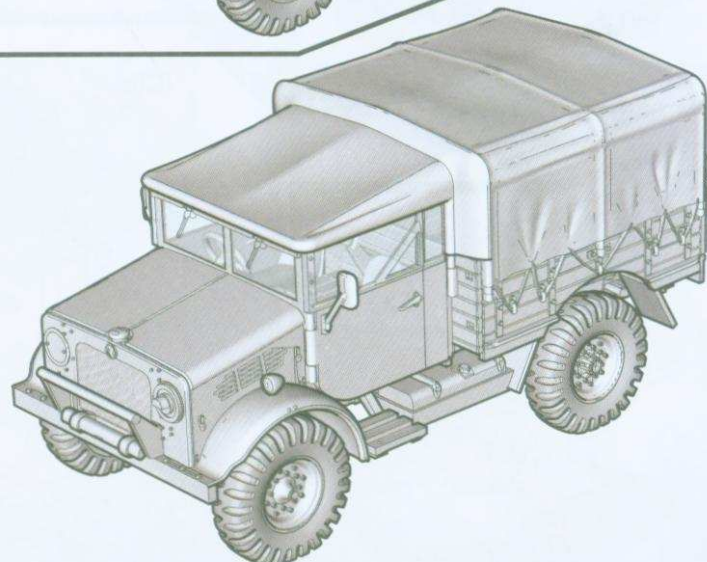

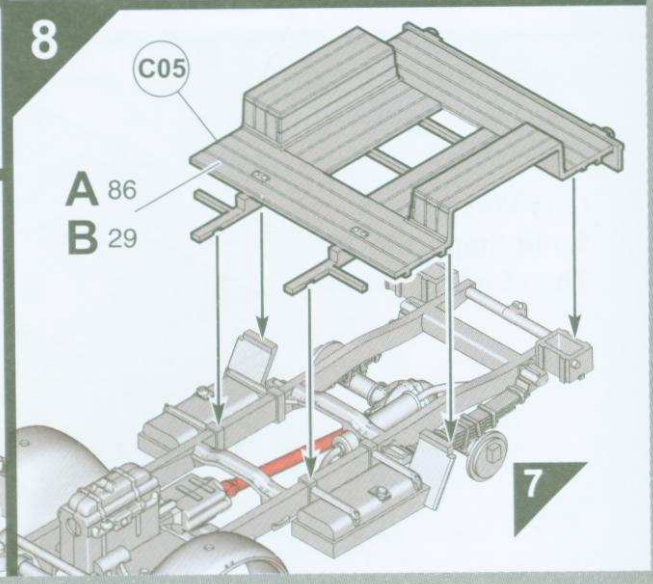
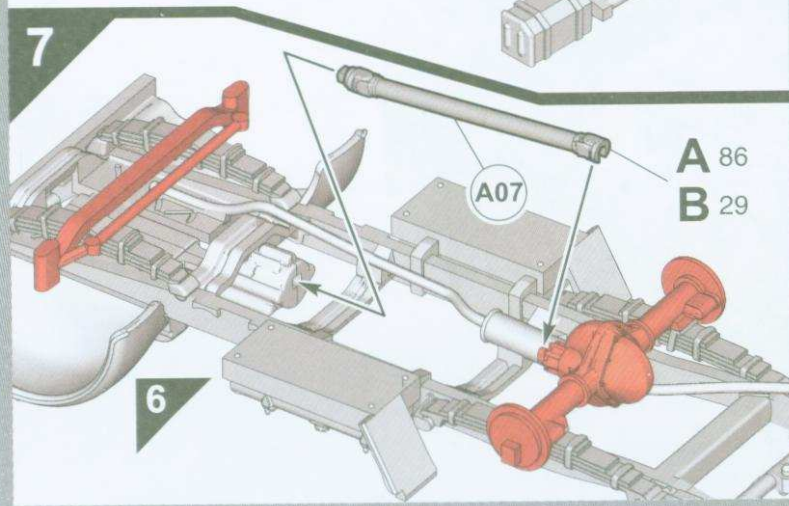
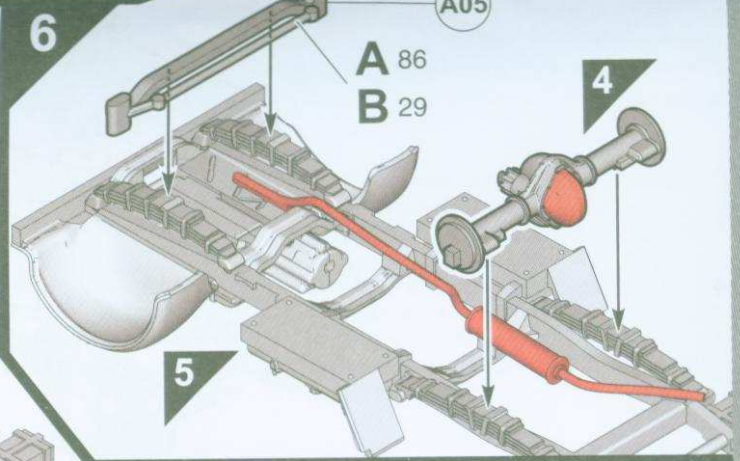
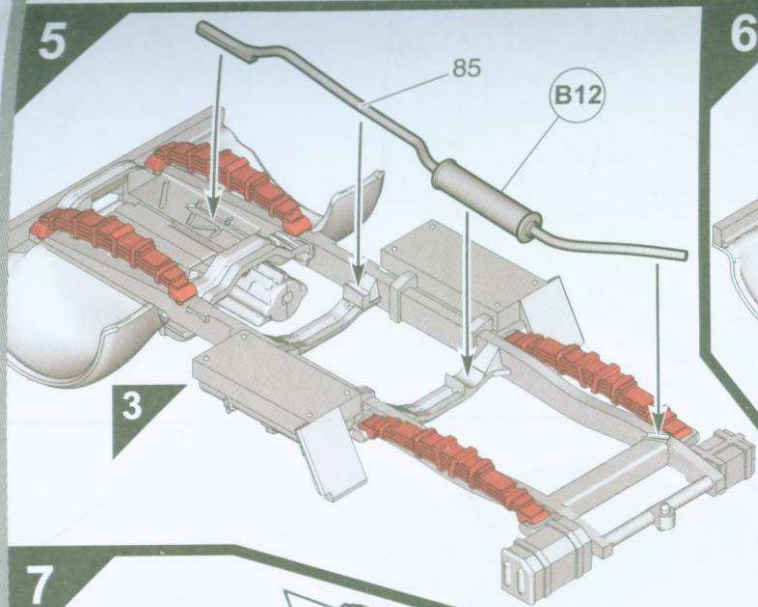
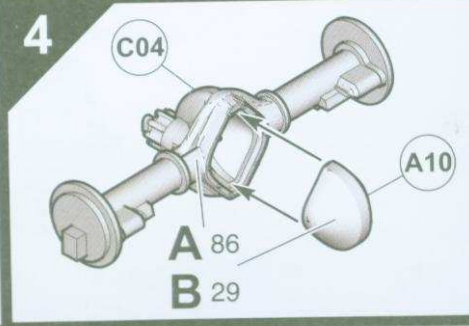
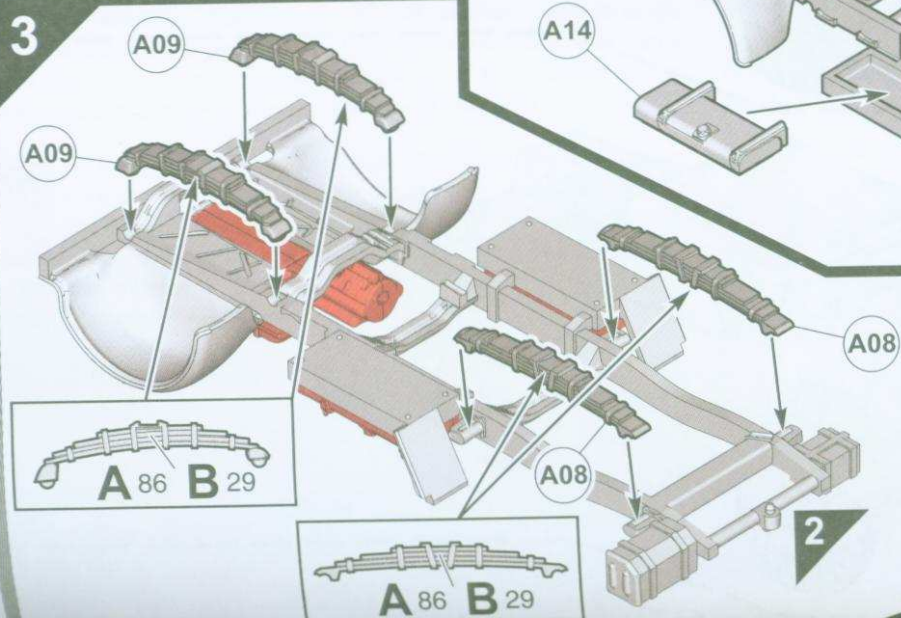
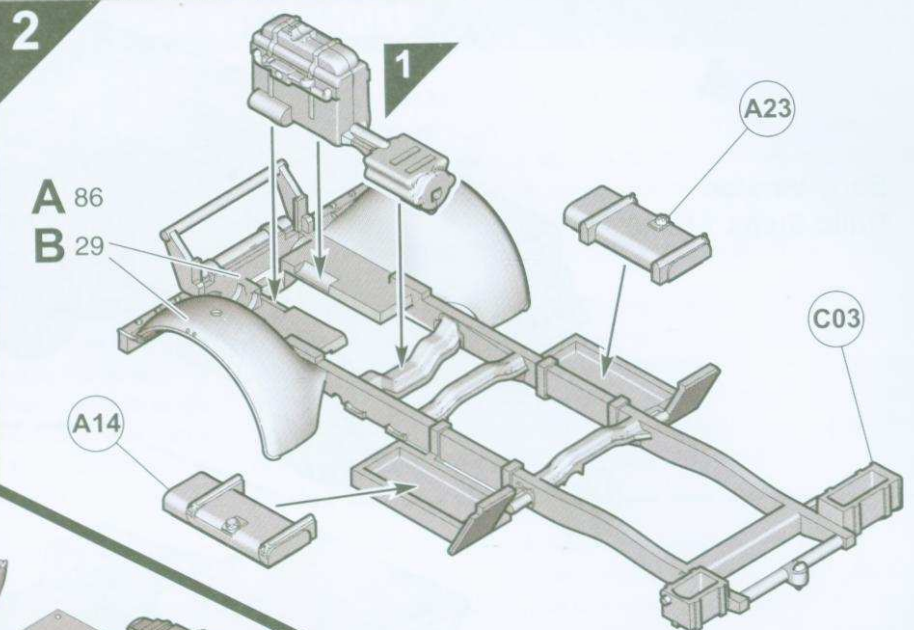
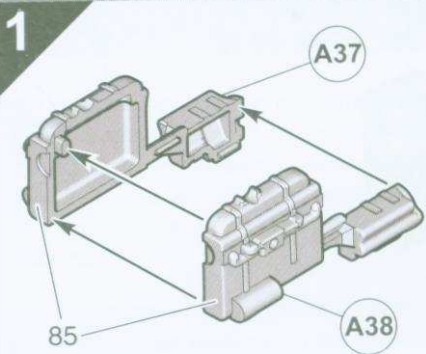

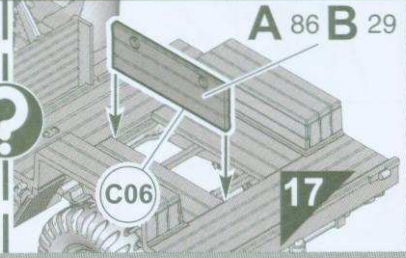
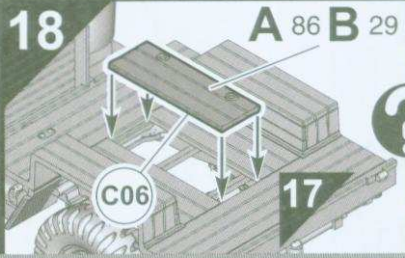
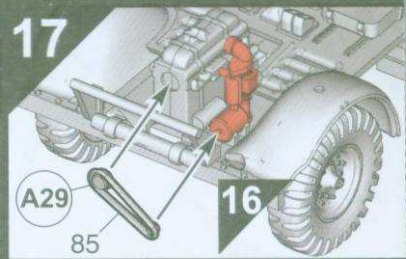
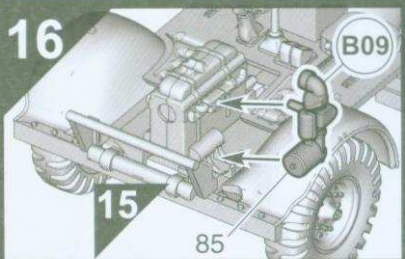
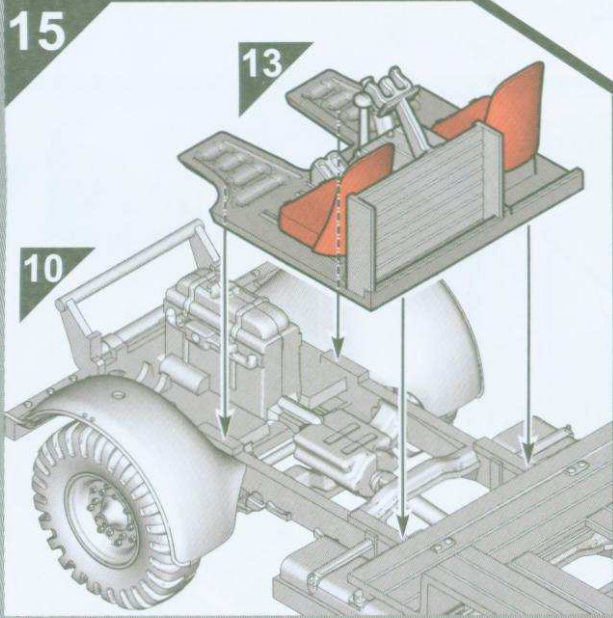
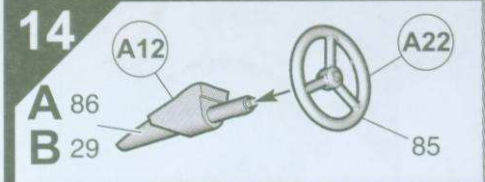
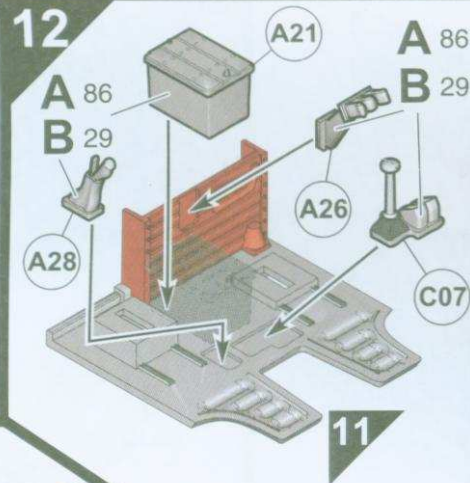
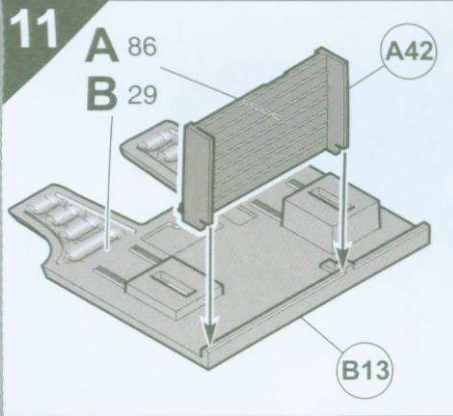
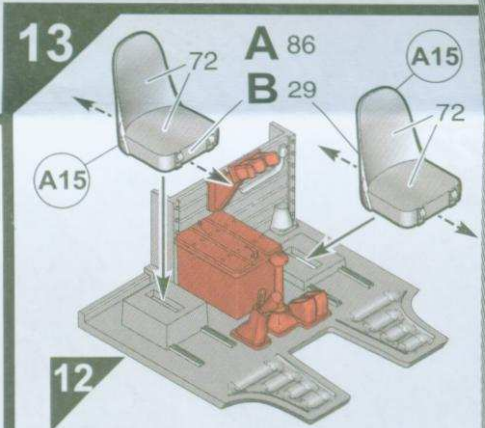
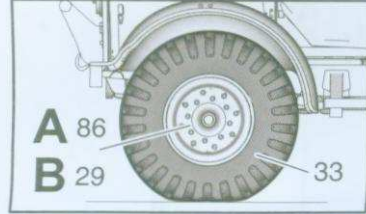
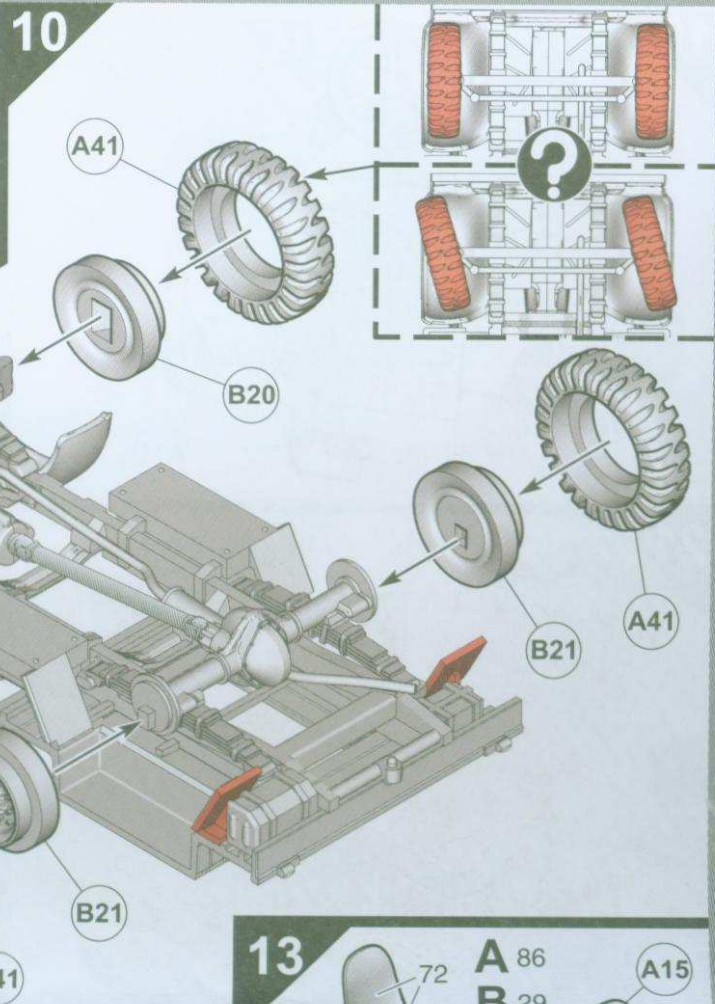
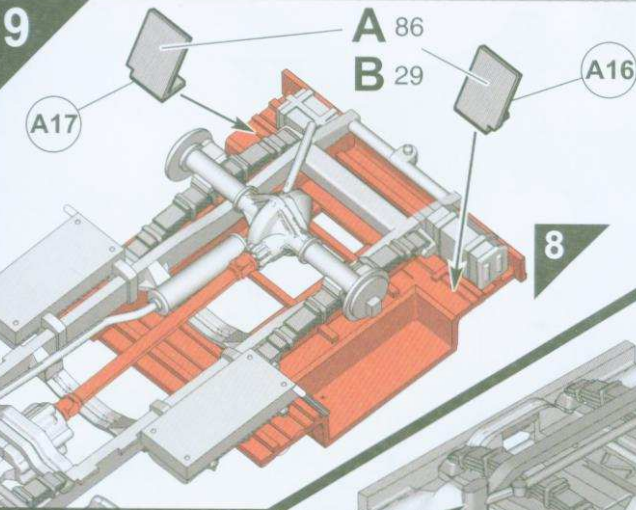
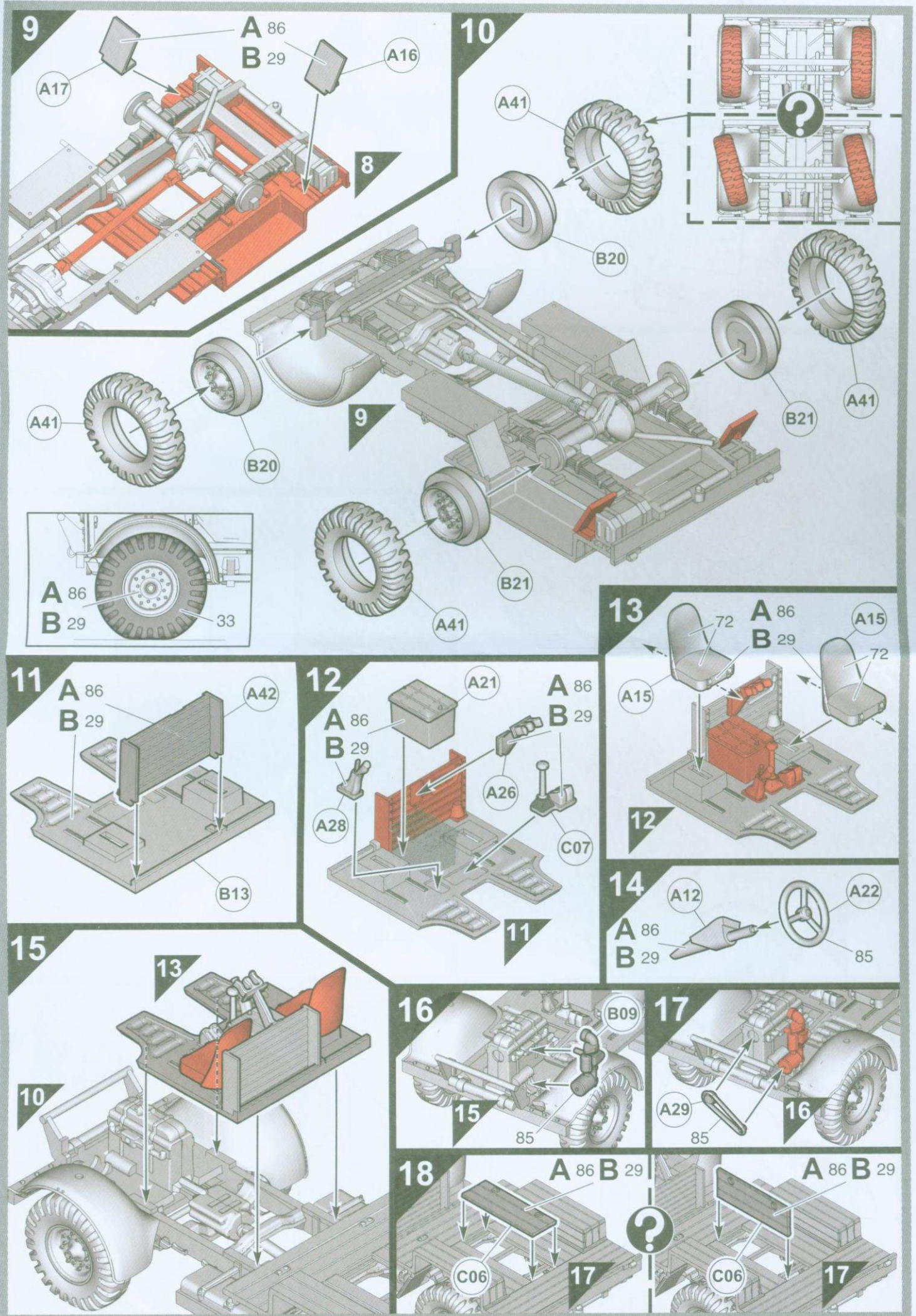

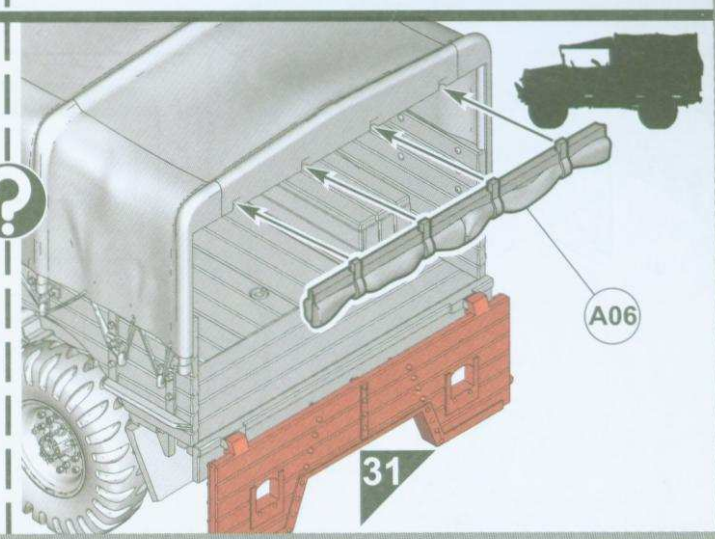
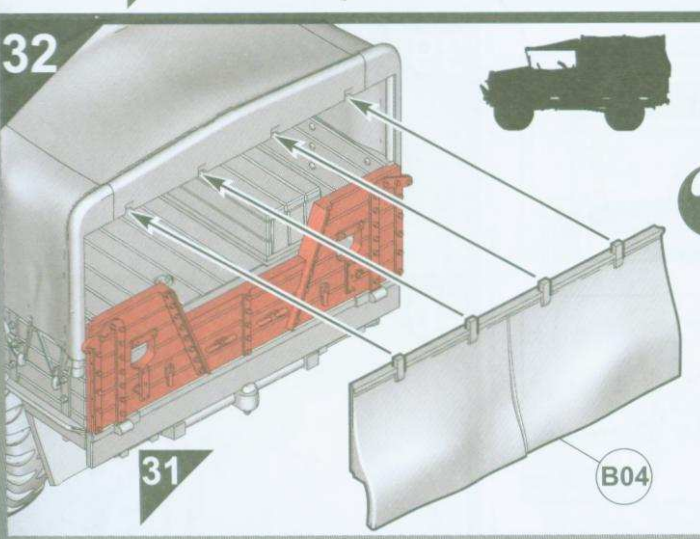
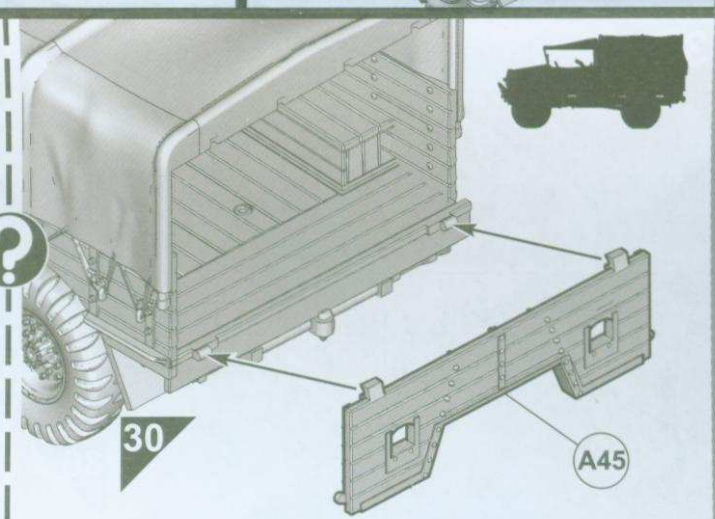
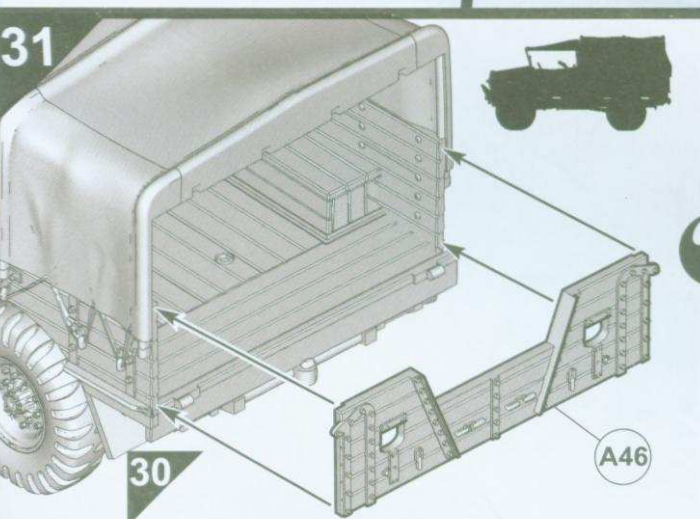
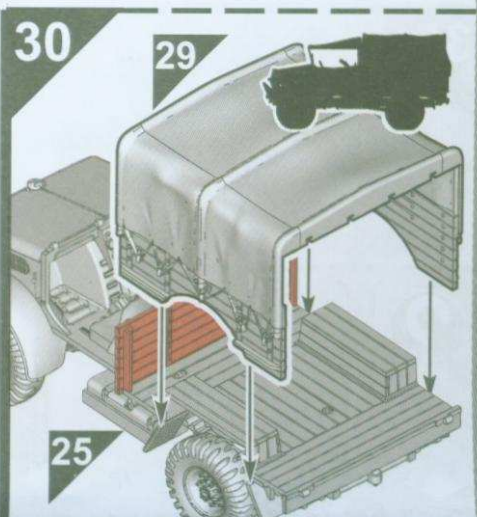
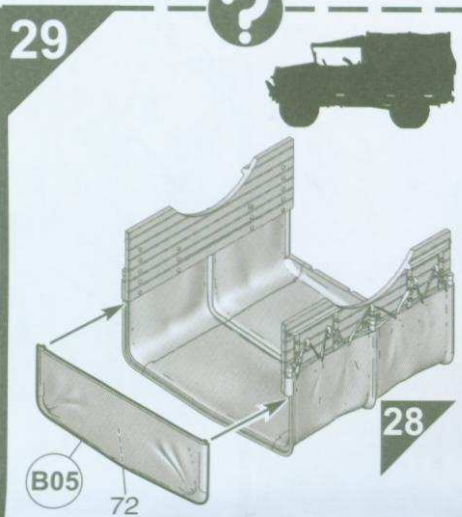
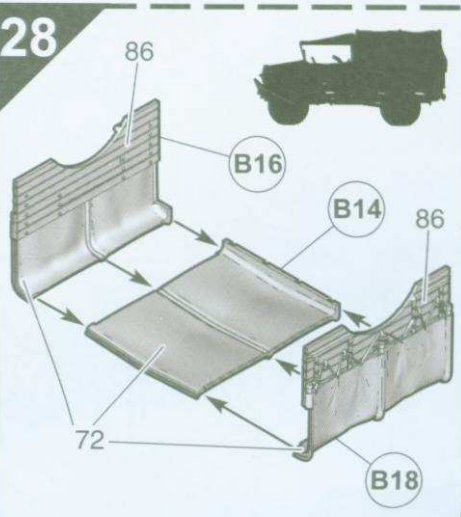
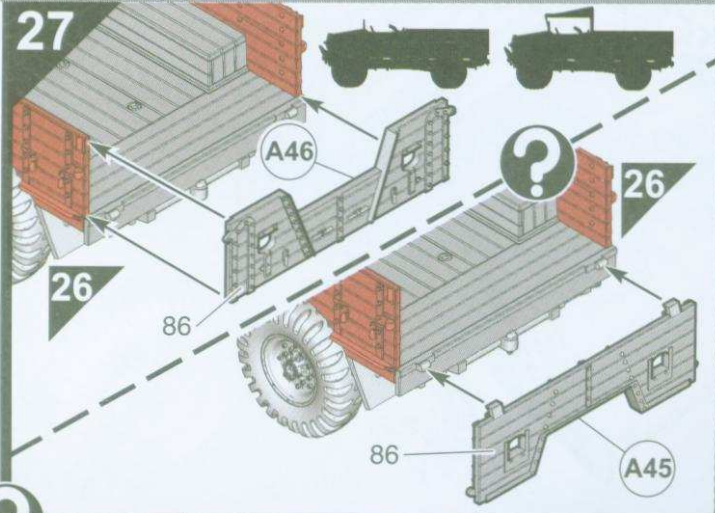
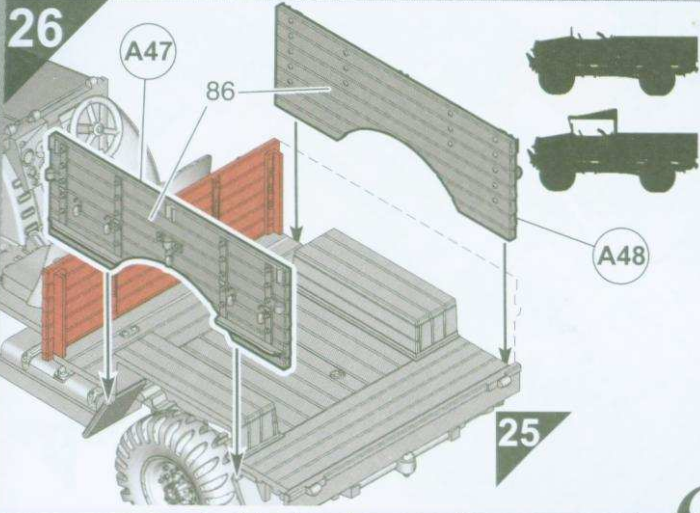

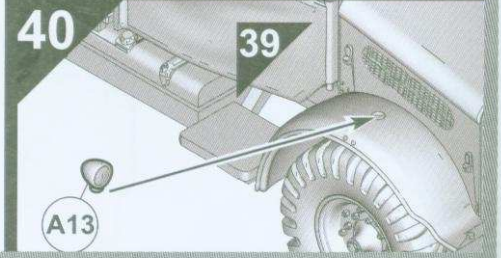
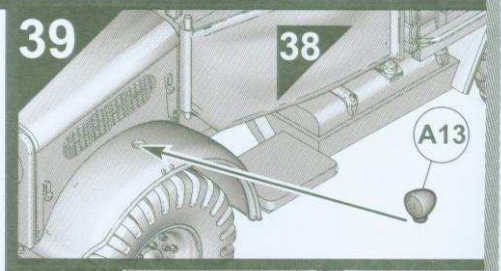
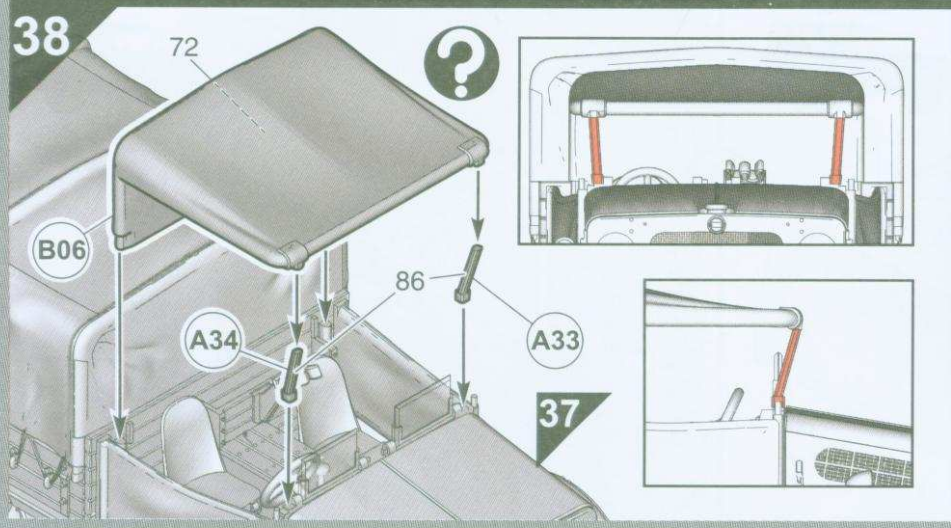
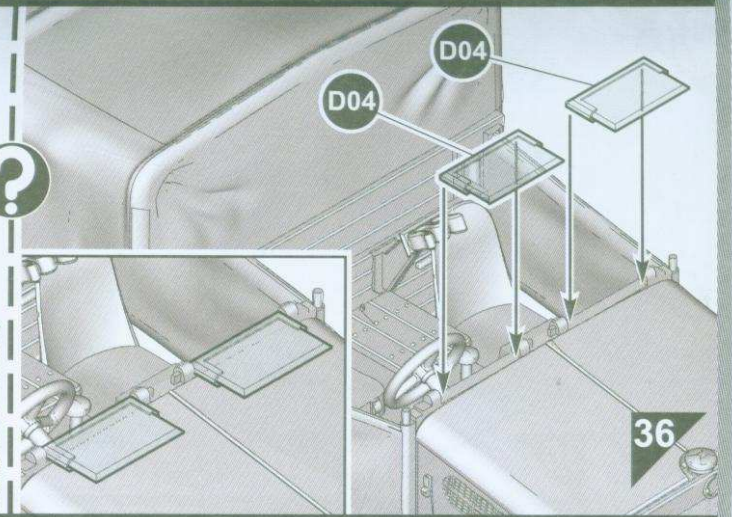
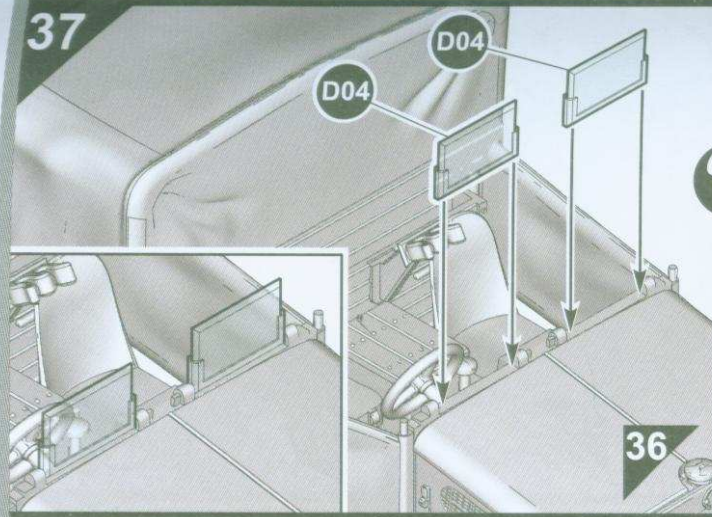
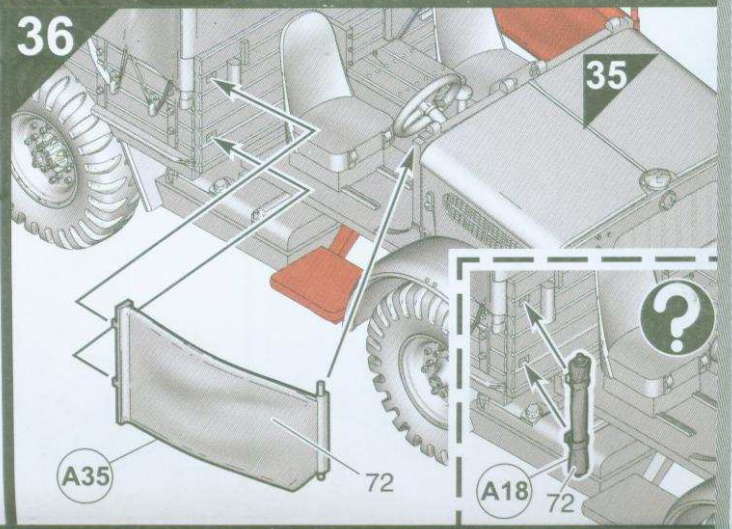
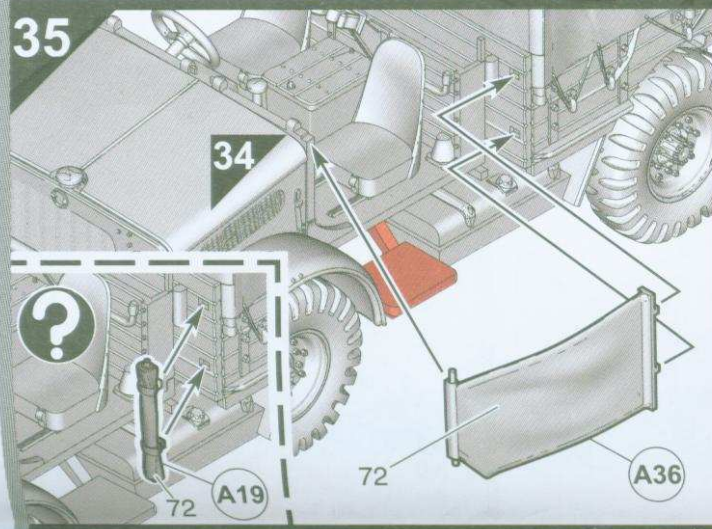
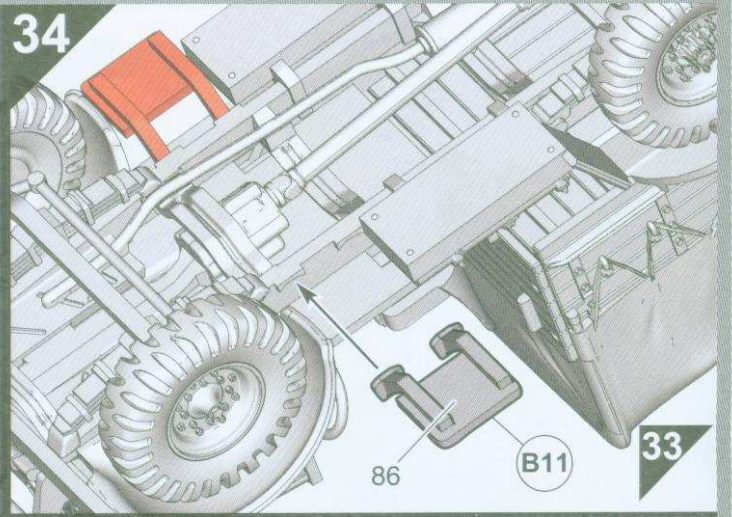
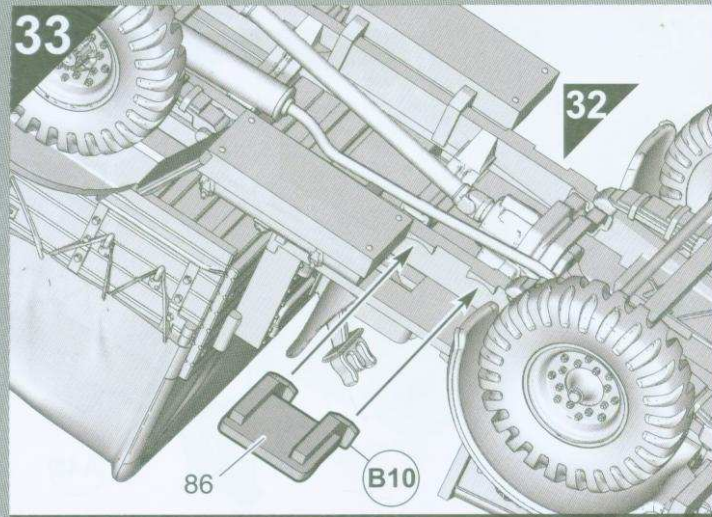

41 For the late version, build steps 1 to 18, then steps 41 to 63.

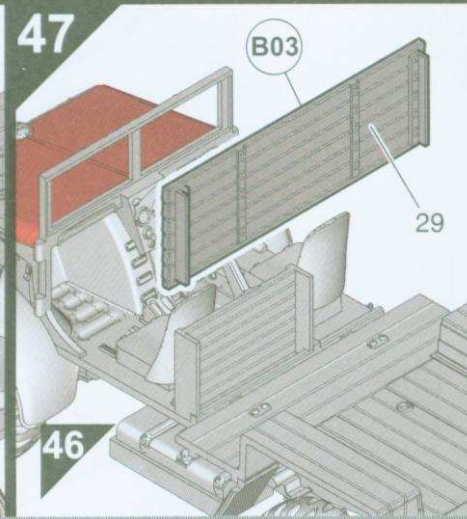
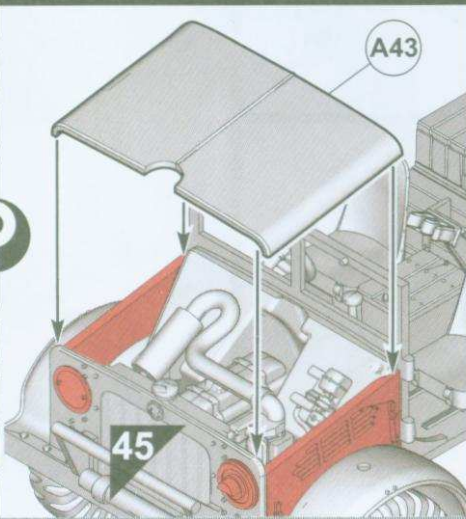
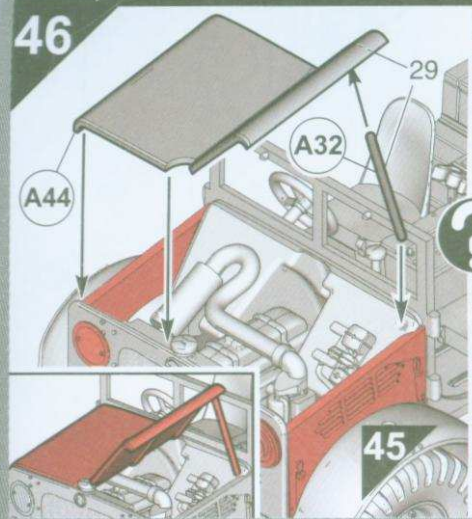
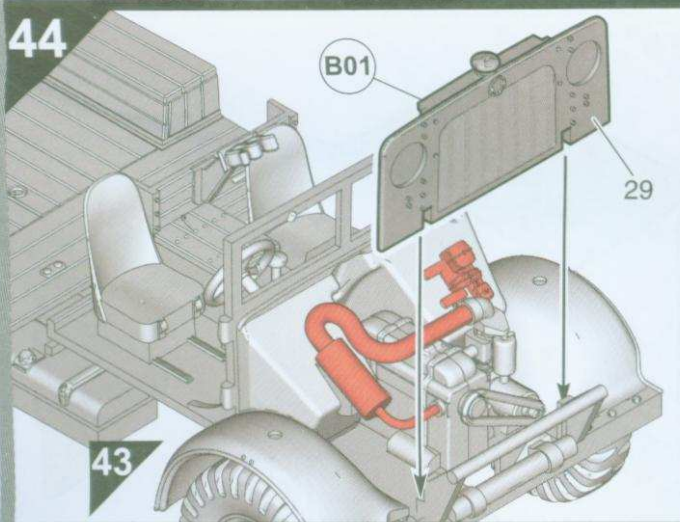
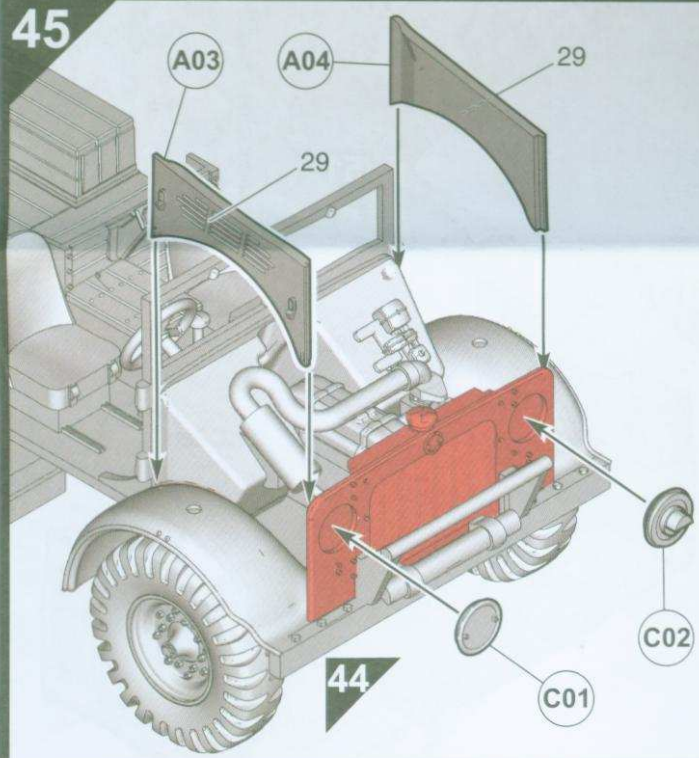
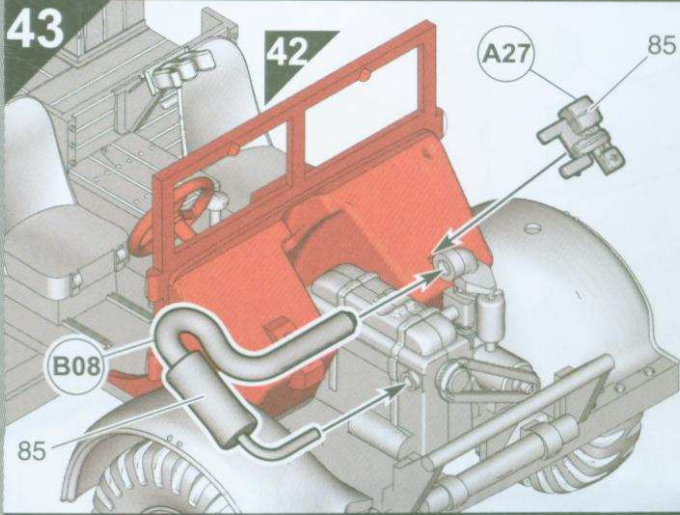
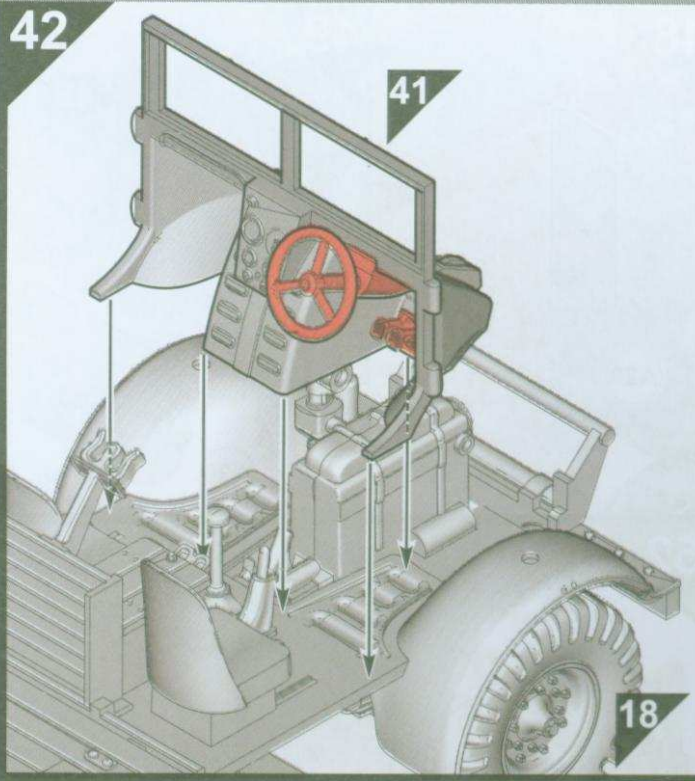
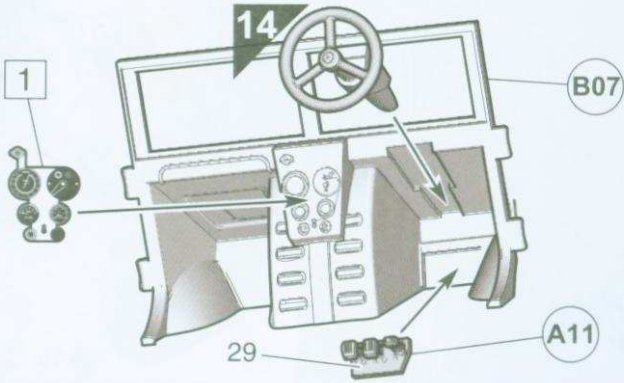

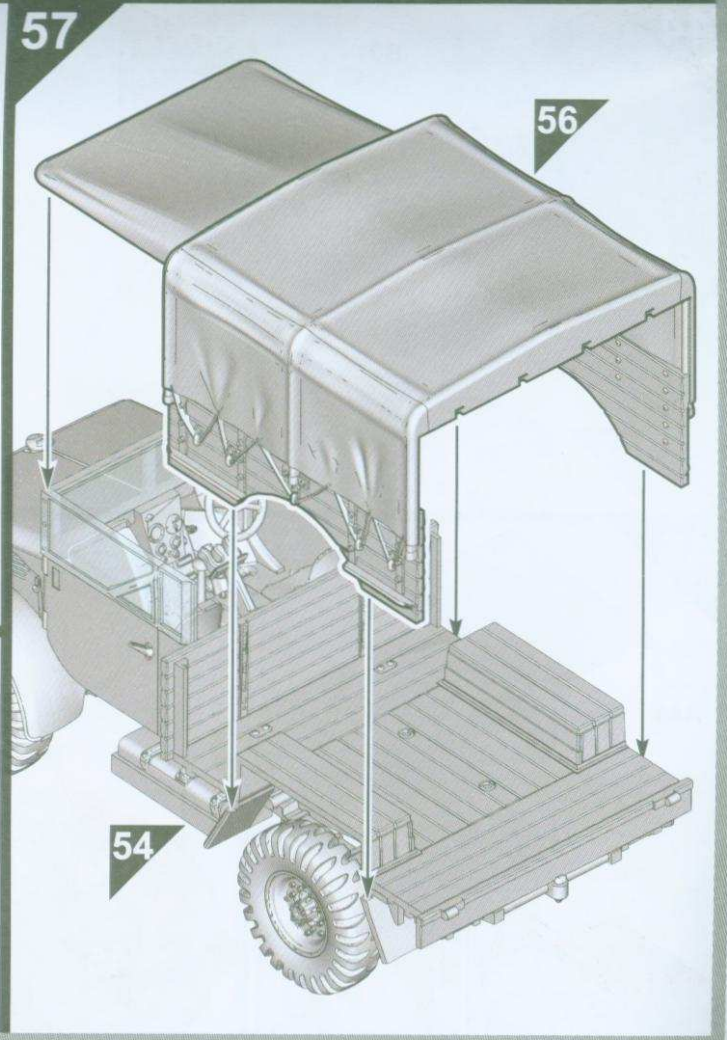
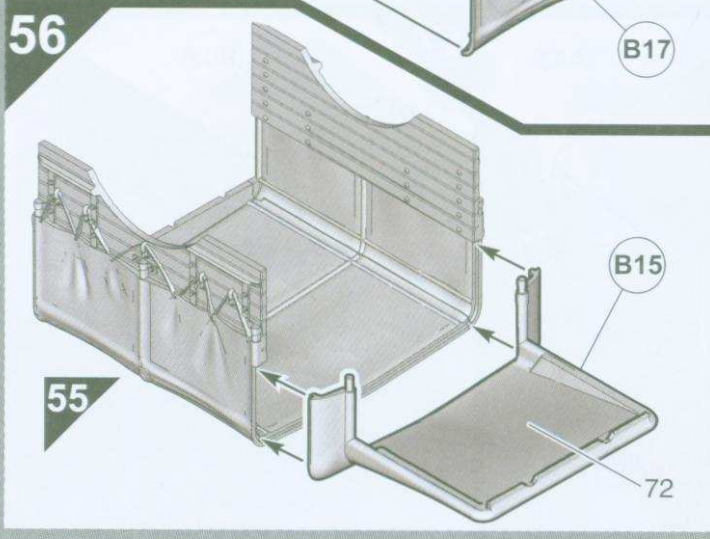
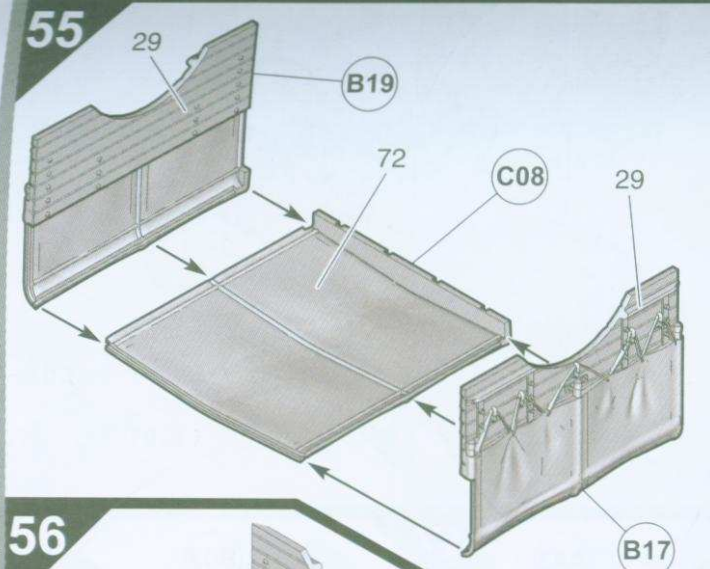
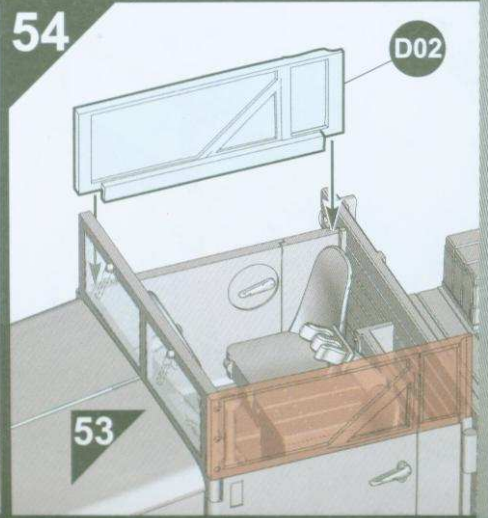
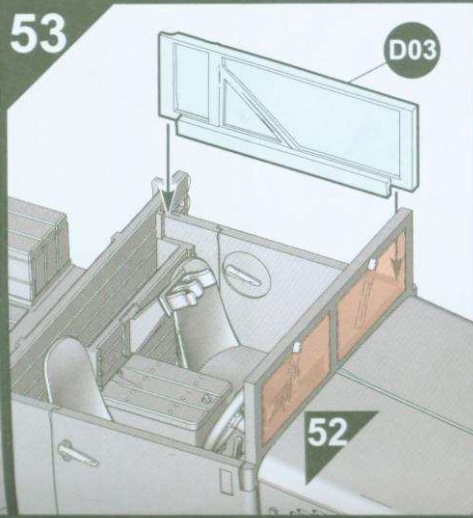
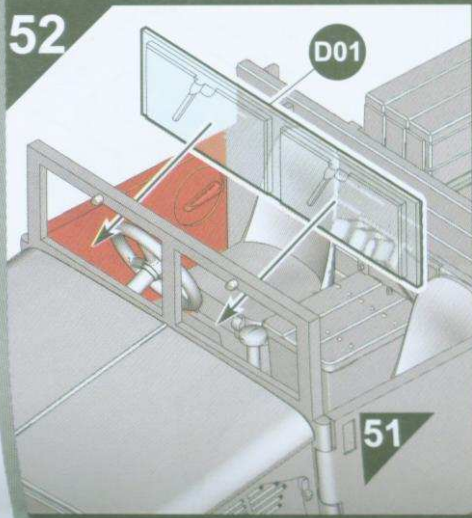
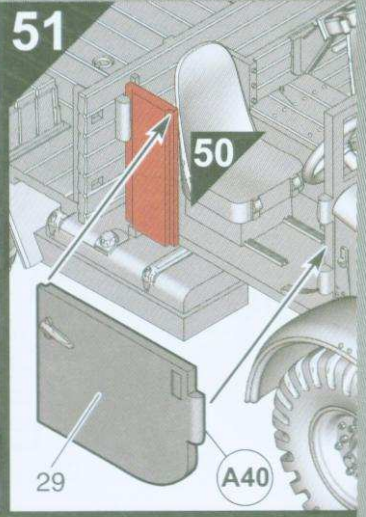
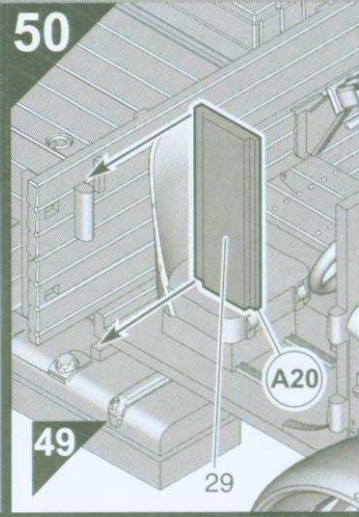
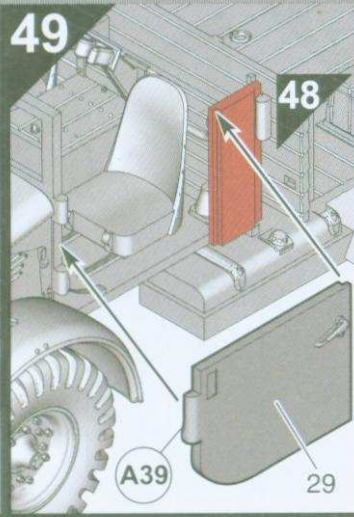
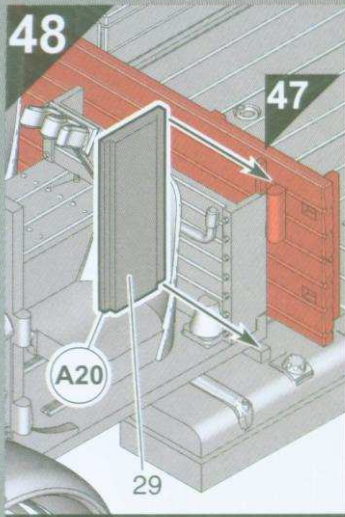

58

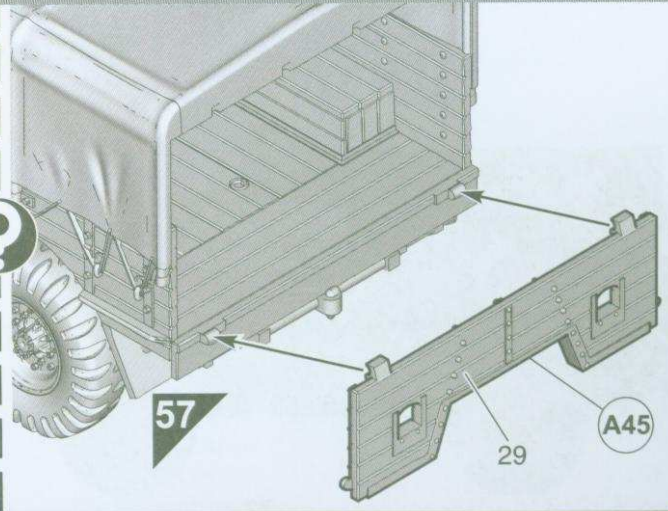
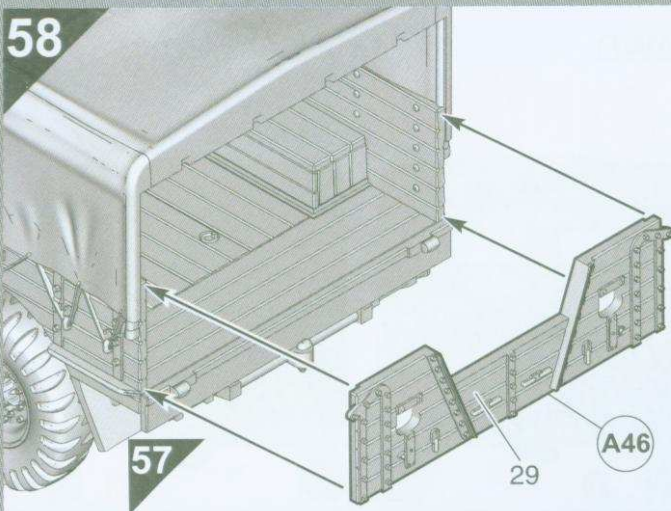

59

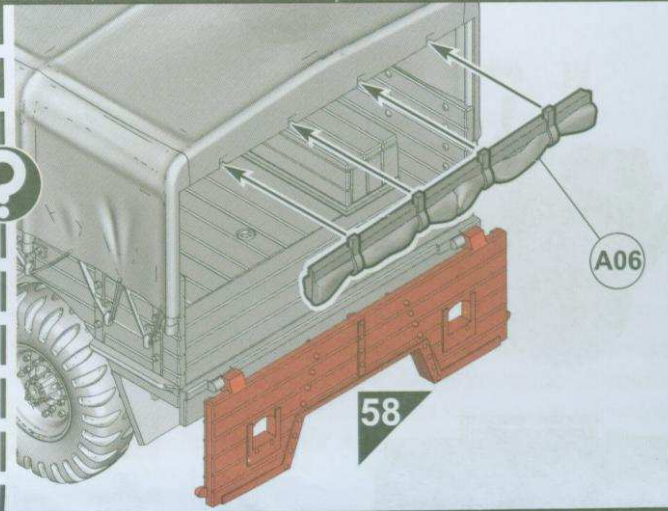
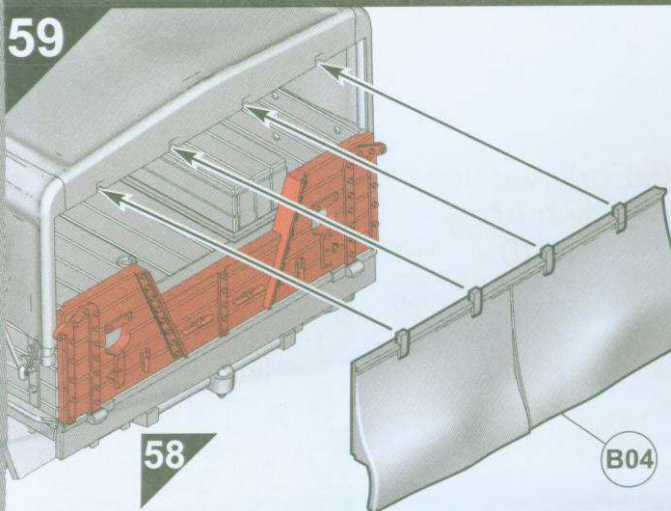

60

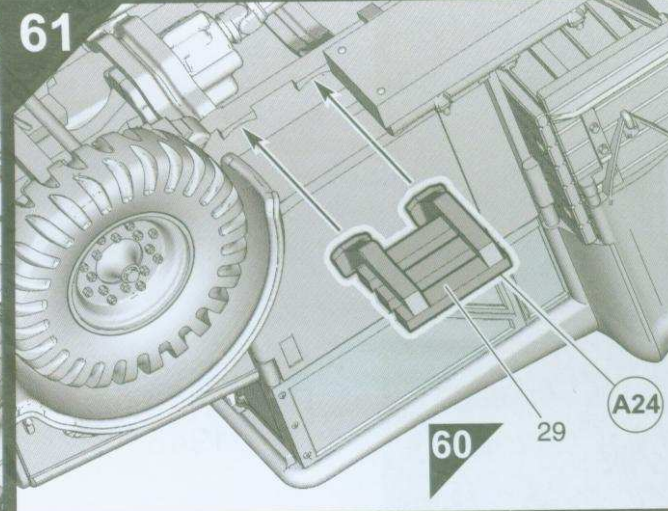
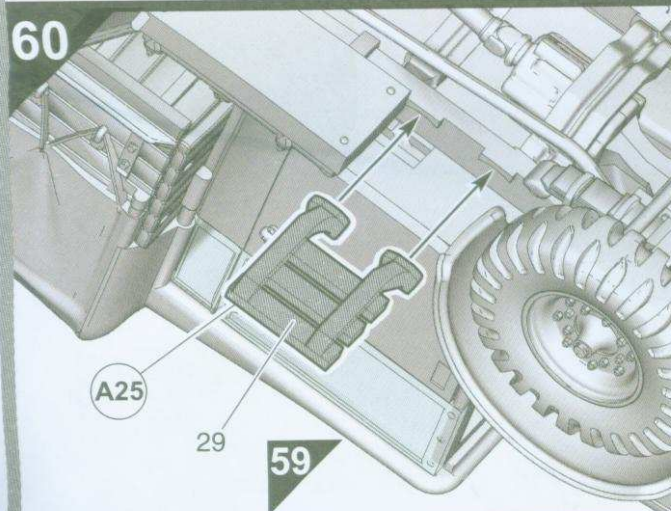

62

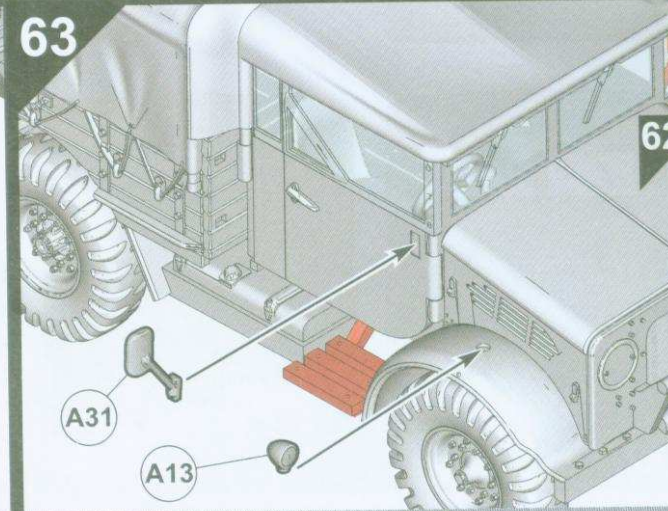
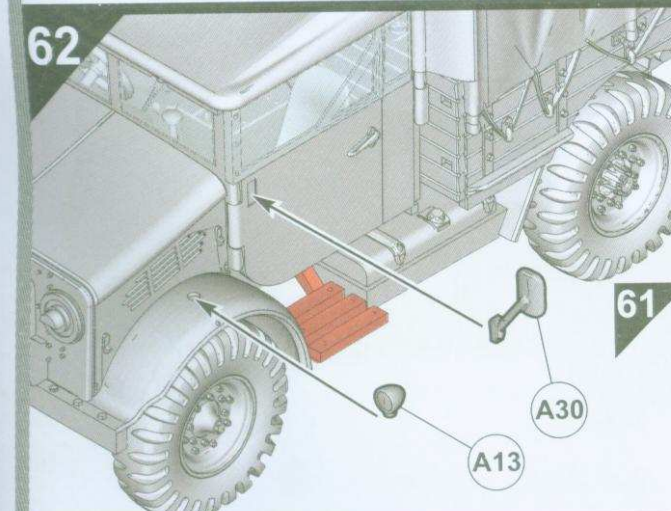

Bedford MWD

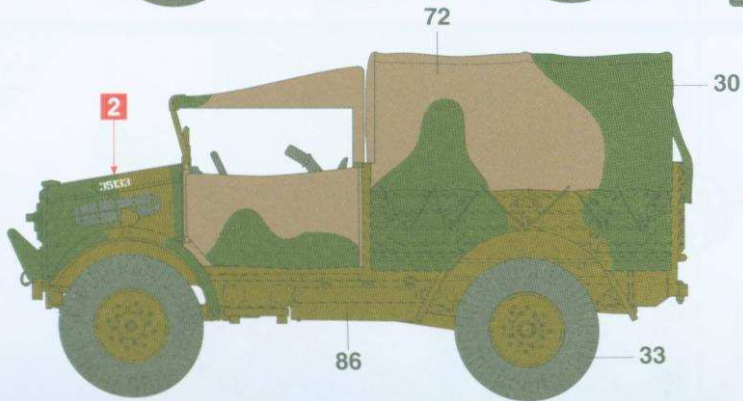
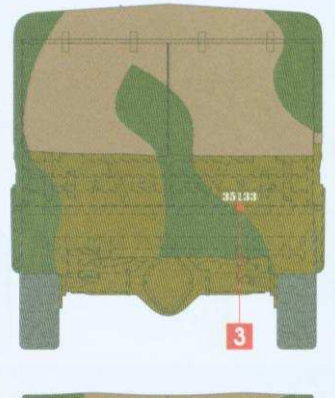
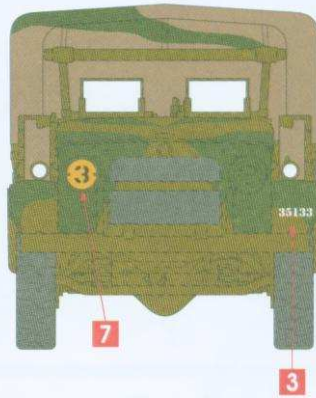
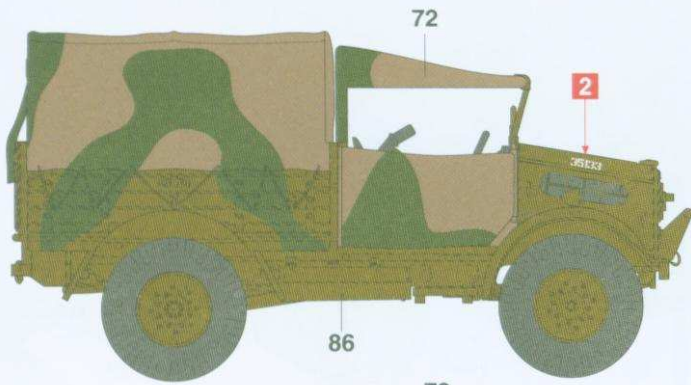

A Early version
British Army
1940



- 29 Matt Dark Earth
- 30 Matt Dark Green
- 33 Matt Black
- 72 Matt Khaki Drill
- 86 Matt Light Olive



B Late version
Royal Air Force
1943

