



# 1:48 Junkers Ju87B-1 Stuka

A07114 SCALE MODEL CONSTRUCTION KIT | Wingspan: 288mm Fuselage Length: 229mm | Two Decal Schemes Included | Two Build Options

**GB**

The Junkers Ju87 Stuka quickly became one of the most infamous, and feared weapons of the Second World War. The two-man dive bomber first saw action in the skies over Spain during the Spanish Civil War. Here the early A and B models proved themselves to be a very accurate tactical weapon and the screaming noise made by special trumpets added to the machines distinctive undercarriage spats created fear in the hearts of enemy civilians. While outdated in appearance, the Stuka did contain some modern features such as automatic dive brakes but overall the design was outmoded. Over the skies of Poland, France and the Low Countries in 1940 the Stuka was able to operate in clear skies and did so effectively but over the South of England during the Battle of Britain, the Stuka came up against staunch RAF fighter opposition, and suffered as a result. After being withdrawn from this front the Stuka was used in the Balkans and the Western Desert, and continued to serve in Russia, as a tank destroyer, until the end of the Second World War.

**FR**

Le Junkers Ju87 Stuka est rapidement devenu l'une des armes les plus infâmes et redoutées de la Deuxième Guerre mondiale. Ce bombardier en piqué biplace entra en action dans les cieux au-dessus de l'Espagne pendant la guerre civile espagnole. C'est là où les premières variantes A et B s'avèrent être une arme tactique très précise. Son bruit strident produit par des sirènes spéciales ainsi que son train d'atterrissage à pantalons caractéristique semaient la terreur parmi les civils ennemis. Même s'il avait l'air démodé, le Stuka disposait de certaines particularités modernes, dont notamment des freins de piqué automatiques, mais dans l'ensemble sa conception était dépassée. En 1940 en Pologne, en France et aux Pays-Bas, les Stuka opérèrent efficacement dans les cieux vides mais au-dessus du sud de l'Angleterre lors de la bataille d'Angleterre ils souffrirent beaucoup en se heurtant à la féroce opposition des chasseurs de la RAF. Après leur retrait de cette première ligne, les Stuka furent utilisés aux Balkans et dans le désert de l'Ouest puis en Russie comme chasseurs de chars jusqu'à la fin de la Deuxième Guerre mondiale.

**DE**

Die Junkers Ju 87 Stuka war eines der bekanntesten und gefürchtetsten Kriegsgeräte des Zweiten Weltkriegs. Die für eine Besatzung von zwei Mann als Sturzkampfflugzeug konzipierte Maschine wurde erstmals im Spanischen Bürgerkrieg eingesetzt. Dabei bewährten sich die bis dahin geheim gehaltenen Versionen A und B als präzise operierende taktische Waffen. Der demoralisierende Heulton ihrer als Jericho-Trompete bekannt gewordenen Sirene und ihre von Weitem erkennbaren Radverkleidungen am Fahrwerk verbreiteten bei feindlichen Zivilisten Angst und Schrecken. Obwohl äußerlich veraltet wirkend, war die Ju 87 mit mehreren modernsten Einrichtungen ausgestattet, beispielsweise mit automatischen Sturzflugbremsen. Ihre Grundkonstruktion war jedoch nicht mehr auf dem letzten technischen Stand. Im Luftraum über Polen, Frankreich und den Niederlanden operierte die Stuka 1940 bei klarem Himmel mit gutem Effekt. In der Luftschlacht um England, die im Süden des Landes ausgefochten wurde, war sie den Jägern der gegnerischen RAF in vieler Hinsicht unterlegen und musste große Verluste hinnehmen. Nach ihrer Zurücknahme von der englischen Front wurde die Stuka dann im Balkan und in der westlichen

**ES**

El Junkers Ju87 Stuka no tardó en convertirse en una de las armas más temidas y tristemente célebres de la Segunda Guerra Mundial. El bombardero en picado biplaza entró por primera vez en acción durante la Guerra Civil española, donde los primeros modelos A y B demostraron su elevado nivel de precisión táctica. El ensordecedor alarido que producían sus características sirenas montadas en los distintivos faldales inferiores contribuía a sembrar el temor entre los civiles del bando enemigo. Aunque un tanto desfasado en su apariencia general, el Stuka contaba con características modernas, como los frenos de picado automáticos. En 1940, sobre los cielos despejados de Polonia, Francia y los Países Bajos, el Stuka pudo operar sin obstáculos, pero durante la Batalla de Inglaterra, tropezó con la obstinada resistencia de los cazas de la RAF. Tras ser retirado de este frente, el Stuka se utilizó en los Balcanes y en el desierto occidental y también prestó servicio como destructor de tanques en Rusia hasta el final de la guerra.

**SE**

Junkers Ju87 Stuka blev snabbt ett av de mest ökända och fruktade vapnen under det andra världskriget. Den tvåsitsiga störtbombaren användes först under det spanska inbördeskriget i vilket de tidiga A- och B-modellerna visade sig vara mycket precisionsmässiga taktiska vapen, och de luftdrivna sirenerna som monterades på flygplanens distinkta landställan satte skräck i fiendens civilbefolkning. Stukas visuella design var föråldrad, men planet var utrustat med vissa moderna funktioner som automatbromsar under störtbombning. 1940 användes Stuka effektivt på klar himmel över Polen, Frankrike, Nederländerna, Belgien och Luxemburg, men över södra England under Slaget om Storbritannien mötte Stuka kraftigt motstånd från RAF:s jaktplan och åsamkades förluster. Efter att ha dragits tillbaka från fronten användes Stuka på Balkan och i det västra ökenområdet, och användes för pansarbekämpning över Ryssland fram till slutet på andra världskriget.

## Specification

Maximum Speed: 242 mph (390km/h)

Range: 311 miles (500 km)

Wingspan: 45 ft 3.3 in (13.8 m)

Length: 36 ft 1.07 in (11.0 m)

Armament: 3 x 7.92mm machine guns 1 x 250kg (550lb) bomb under the fuselage, 4 x 50kg (110lb) bombs two under each wing.

## Spécification:

Vitesse maximale: 390 km/h

Autonomie: 500 km

Envergure: 13,8 m

Longueur: 11,0 m

Armement: trois mitrailleuses de 7,92 mm, une bombe de 250 kg sous le fuselage, quatre bombes de 50 kg dont deux sous chaque aile.

Wüste von Nordafrika eingeeetzt. Außerdem war sie in der Sowjetunion bis Kriegsende als Panzerjäger in Verwendung.

## Spezifikation:

Höchstgeschwindigkeit: 390 km/h

Reichweite: 500 km

Spannweite: 13,8 m

Länge: 11,0 m

Bewaffnung: drei 7,92 mm MG; eine 250 kg Bombe unter dem Rumpf; vier 50 kg Bomben unter den Flügeln (zwei an jeder Seite).

## Especificación:

Velocidad máxima: 390 km/h

Autonomía: 500 km

Envergadura: 13,8 m

Longitud: 11,0 m

Armamento: 3 ametralladoras de 7,92 mm; 1 bomba de 250 kg bajo el fuselaje; 4 bombas de 50 kg, dos bajo cada ala.

## Specifikation:

Maximal hastighet: 390 km/h

Räckvidd: 500 km

Spännvidd: 13,8 m

Längd: 11,0 m

Bestyckning: 3 st. 7,92 mm-kulsprutor, 1 st. 250 kg-bomb under skrovet och 4 st. 50 kg-bomber, två under vardera vingen.

## FOR BEST RESULTS:

Surfaces to be painted should be clean – before parts are removed from the sprue, wash in warm, soapy water, rinse and dry thoroughly. Stir paints thoroughly before use.

## PLEASE NOTE:

Some parts in the kit may not be required to build the model specified.

**HORNBY  
HOBBIES**



# Assembly Instructions

**GB** Study drawings and practise assembly before cementing parts together. Carefully scrape paint from cementing surfaces. All parts are numbered. Paint small parts before assembly. To apply decals cut sheet as required, dip in warm water for a few seconds, slide off backing into position shown. Use in conjunction with box artwork. Not appropriate for children under 36 months of age, due to the presence of small detachable parts.

**FR** Étudier attentivement les dessins et simuler l'assemblage avant de coller les pièces. Gratter soigneusement toute peinture sur les surfaces à coller. Toutes les pièces sont numérotées. Peindre les petites pièces avant l'assemblage. Pour coller les décalcomanies, découper le motif, le plonger quelques secondes dans de l'eau chaude puis le poser à l'endroit indiqué en décollant le support papier. Utiliser conjointement avec les illustrations sur la boîte. Ne convient pas aux enfants de moins de 36 mois - présence de petits éléments détachables.

**DE** Vor dem Zusammenkleben der Teile die Zeichnungen sorgfältig ansehen und die zu verklebenden Teile zur Vermeidung möglicher Fehler versuchsweise zusammenfügen. Dann an den Klebeflächen vorhandene Farbbeschichtung vor dem Zusammenkleben vorsichtig abkratzen. Alle Bestandteile sind mit Nummern versehen. Kleine Teile vor dem Zusammenbau bemalen. Abziehbilder wie gewünscht ausschneiden. Vor dem Anbringen einige Sekunden in warmes Wasser tauchen und dann vom Trägerpapier in ihre vorgesehene Position schieben. Dabei die Abbildungen auf der Schachtel beachten. Nicht für Kinder unter 36 Monaten geeignet, da abnehmbare bzw. lose angebrachte Kleinteile enthalten sind.

**ES** Estudiar los dibujos y practicar el montaje antes de pegar las piezas. Raspar cuidadosamente la pintura en las superficies de contacto antes de pegar las piezas. Todas las piezas están numeradas. Es conveniente pintar las piezas pequeñas antes de su montaje. Para aplicar las calcomanías, cortarlas de la hoja, sumergirlas en agua tibia durante unos segundos y deslizarlas a la posición indicada. Utilizar en conjunción con la ilustración de la caja. No es adecuado para niños menores de 36 meses, ya que contiene piezas pequeñas que podrían soltarse.

**IT** Studiare i disegni ed esercitarsi a montare i vari pezzi prima di fissarli con la colla. Raschiare con cura le tracce di vernice dalle superfici da incollare. Tutti i pezzi sono numerati. Verniciare i pezzi di piccole dimensioni prima di montarli. Per applicare le decalcomanie, ritagliare il foglio nel modo richiesto, immergere in acqua calda per alcuni secondi, quindi staccare la decalcomania dalla carta di supporto e posizionarla nel punto desiderato. Usare le decalcomanie come indicato nell'illustrazione riportata sulla confezione. Non adatto a bambini di età inferiore a 36 mesi per la presenza di componenti di piccole dimensioni che potrebbero staccarsi.

**DK** Studér tegningerne nøje og forsøg at sætte delene sammen, inden de klæbes sammen. Skrab forsigtigt malingen af de overflader, der skal klæbes sammen. Alle dele er nummererede. Små dele skal males, før de monteres. Overføringsbillederne påføres ved at klippe dem ud af arkene, som påkrævet, dyppe dem i varmt vand i nogle få sekunder, hvorefter underlaget glides af i de viste positioner. Påføres ifølge illustrationerne på æsken. Ikke egnet til børn under 3 år på grund af tilstedeværelse af små aftagelige dele.

**NL** Tekeningen bestuderen en delen in elkaar zetten alvorens deze te lijmen. Lak voorzichtig van lijmvlakken afschrapen. Alle delen zijn genummerd. Kleine delen vóór montage verven. Voor aanbrengen van stickers, gewenste stickers uit het vel knippen, een paar seconden in warm water dompelen en dan van het schutblad af op afgebeelde plaats schuiven. Hierbij afbeelding op doos raadplegen. Niet geschikt voor kinderen onder 3 jaar, omdat kleine deeltjes gemakkelijk kunnen losraken.

**SE** Studera bilderna noggrant och sätt ihop delarna innan du limmar ihop dem. Skrapa försiktigt bort färg från limmade delar. Alla delarna är numrerade. Måla smådelarna före ihopsättning. Sätt fast dekalerarna genom att klippa ark, doppa i varmt vatten några sekunder och låta baksidan glida på plats som bilden visar. Använd enligt bildanvisningarna på kartongen. Rekommenderas ej för barn under 3 år. Innehåller löstagbara smådelar.

**FI** Tutustu piirroksiin ja harjoittele kokoamista, ennen kuin liimaat osat yhteen. Raaputa maali varovasti pois liimattavilta pintoilta. Kaikki osat on numeroitu. Maalaa pienet osat ennen kokoamista. Siirtokuvien kiinnittämisessä leikkaa ne arkista tarpeen mukaan. Kasta kuva lämpimään veteen muutaman sekunnin ajaksi, mutta takapuolen liukka kuvalle osoitetun kohtaan. Käytetään yhdessä laatikon kuvituksen kanssa. Ei sovelleta alle kolmivuotiaille lapsille. Paljon irotettavia pikkusasia.

**PT** Estudar atentamente os desenhos e experimentar a montagem. Raspar cuidadosamente as superfícies de modo a eliminar pintura antes de colar. Todas as peças estão numeradas. Pintar as pequenas peças antes de colar. Para aplicar as decalcomanias, cortar as folhas e mergulhar em água morna por alguns segundos, depois deslizar e aplicar no respectivo lugar, como indicado nas ilustrações na caixa. Não convém a uma criança de menos de 36 meses devido à presença de pequenos elementos destacáveis.

**PL** Przed przystąpieniem do sklepania przestuduj uważnie rysunki i przećwicz składanie części. Ostrożnie zeskrub ze sklepanych powierzchni farbę. Wszystkie części są ponumerowane. Drobnе części pomaluj przed ich złożeniem. Celem przeniesienia kalkomanii wytnij ją z arkusza, zanurz na kilka sekund w letniej wodzie i zsuń z podłoża na wyznaczone miejsce. Używaj w połączeniu ze wzorami na pudełku. W związku z obecnością wielu drobnych, rozbiernych części, nieodpowiednie dla dzieci poniżej 3 lat.

**EL** Μελετήστε προσεκτικά τα σχέδια και συναρμολογήστε για πρώτη φορά τα κομμάτια χωρίς να τα συγκολλήσετε. Αφαιρέστε επιμελώς την πλαστική βαφή από τις επιφάνειες τις οποίες θα συγκολλήσετε. Όλα τα κομμάτια είναι αριθμημένα. Χρωματίστε τα μικρά κομμάτια πριν από τη συναρμολόγηση. Για να κολλήσετε τις καλκομανίες, κόψτε γύρω από το σχέδιο όπως απαιτείται, βυθίστε το μερικά δευτερόλεπτα σε χλιαρό νερό και μετά τοποθετήστε το στη θέση που υποδεικνύεται, αφαιρώντας τη μεμβράνη που το καλύπτει. Λάβετε υπόψη σας ταυτόχρονα την εικονογράφηση του κουτιού. Ακατάλληλο για παιδιά ηλικίας κάτω των 36 μηνών λόγω ύπαρξης μικρών κομματιών που αποσπώνται.

## ASSEMBLY ICON INSTRUCTIONS

<p><b>Assembly phase</b> Phase de montage Montagephase Fase de montaje Monteringsfasen Fase di montaggio Montagefase Fase de montagem Monteringsfase Kokoomisvaihe Faza składowania Φάση συναρμολόγησης</p>	<p><b>Cement</b> Coller Kleben Pegar Limma Incollare Lijmen Collar Klæbes Liimaa Kleć Συγκολλήστε</p>	<p><b>Do not cement together</b> No pas coller Nicht kleben No pegar Limma inte Non incollare Niet lijmen Não colar Skal ikke klæbes Äls liimaa Nie kleć Μη συγκολλήσετε</p>	<p><b>Indicates final location</b> Indique l'emplacement final Zeigt Endposition Indica la ubicación definitiva Anger slutmonteringsplats Sede di montaggio finale Geeft uiteindeelijke locatie aan Indica localização final Viser endelig placering Osoittaa lopullisen sijainnin Oznacza miejsce ostatecznego umieszczenia Υποδεικνύει τελική θέση</p>	<p><b>1 / 2 / 3 / 4 / 5 / 6 / 7 / 8 / 9 / 10 / 11 / 12 / 13 / 14 / 15 / 16 / 17 / 18 / 19 / 20 / 21 / 22 / 23 / 24 / 25 / 26 / 27 / 28 / 29 / 30 / 31 / 32 / 33 / 34 / 35 / 36 / 37 / 38 / 39 / 40 / 41 / 42 / 43 / 44 / 45 / 46 / 47 / 48 / 49 / 50 / 51 / 52 / 53 / 54 / 55 / 56 / 57 / 58 / 59 / 60 / 61 / 62 / 63 / 64 / 65 / 66 / 67 / 68 / 69 / 70 / 71 / 72 / 73 / 74 / 75 / 76 / 77 / 78 / 79 / 80 / 81 / 82 / 83 / 84 / 85 / 86 / 87 / 88 / 89 / 90 / 91 / 92 / 93 / 94 / 95 / 96 / 97 / 98 / 99 / 100</b> part(s) provided part(s) fournie(s) mitgeliefert pieza(s) alternativa(s) del(ar) ingår componenti alternativ forniți onderdelen meegeleverd formada(s) medföljer osot pakkauksessa zamiennie αντικαταστάσιμα κομμάτια</p>	<p><b>x2</b> Repeat this operation Répéter l'opération Vorgang wiederholen Repetir la operación Upprepa åtgärden Ripetere l'operazione De verrichting herhalen Repetir a operação Manovren gentages Toista toimenpite Powtórz operację Επανάλαβε τη διαδικασία</p>	
<p><b>Decals</b> Décalcomanies Abziehbild Calcomanias Dekaler Decalcomanie Stickers Decalcomania Billedoverføring Siirtokuvat Kalkomanie Χαλκομανίες</p>	<p><b>Crystal part</b> Pièce cristal Kristallteil Pieza de cristal Kristallid Pezzo cristallo Kristallen onderdeel Peça de cristal Krystalstykke Kristalliosa Частина кристаллова Κομμάτι κρυστάλλου</p>	<p><b>Weight</b> Lester Beschweren Lastrar Belasta Applicare un peso Verzwaren Lastrar Påfør vægt Aseta vastapaino Obciążać balastem Επιθέστε βάρος</p>	<p><b>Remove by filling</b> Lester Abfellen Elir Ta borras Abfillen Abfüllen Aseta vastapaino Uitvullen Αφαιρέστε λιμάροντας με λίμα</p>	<p><b>Drill or pierce</b> Percer Durchbohren Perforar Borra Trapanare o forare Boren of doorboren Furar Gennembor Poraa tai puhkaise Wywierć lub przedziurawić Τρυπήστε</p>	<p><b>Cut</b> Découper Schneiden Cortar Skär Tagliare Snijden Cortar Skær Leikkaa Przeciąć Κόψτε</p>	<p><b>Humbrol paint number</b> No peinture Humbrol Humbrol-Farbnummer No de pintura Humbrol Humbrol färg nummer No vernice Humbrol Humbrol verfnummer No de pintura Humbrol Humbrol målingsnummer Humbrol-maalain numero Nr farby Humbrol Νόμepo χρώματος Humbrol</p>

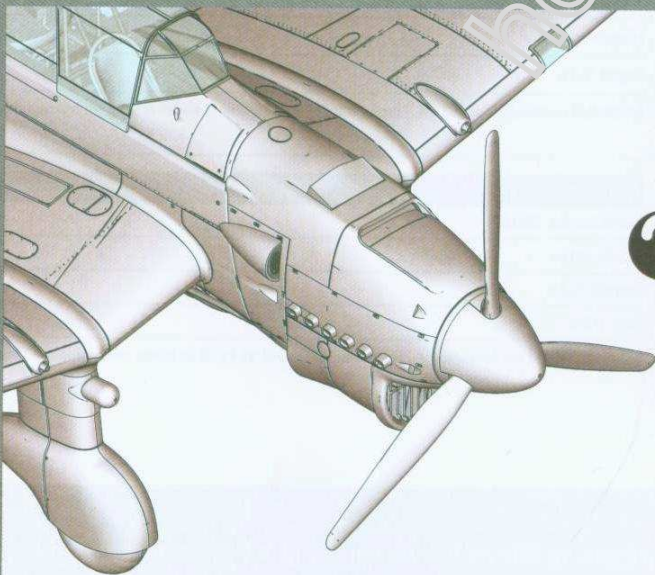

To build the model with the engine cowlings in place miss out steps 34 to 52.

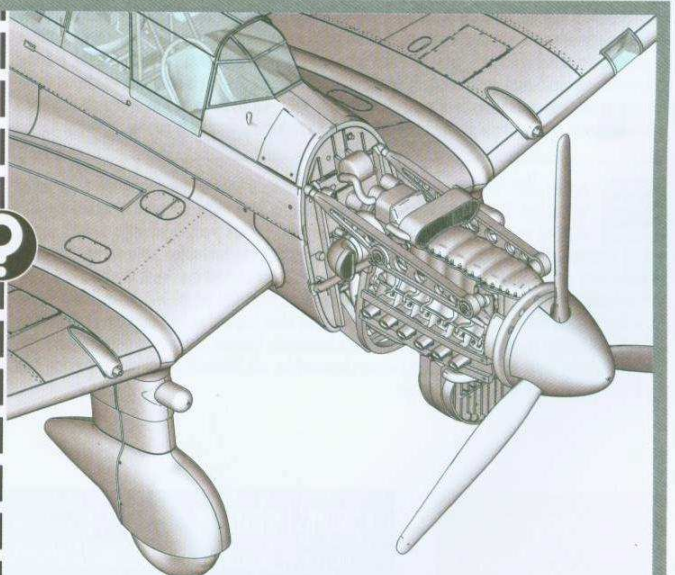

To build the model with the engine in place miss out steps 53 to 65.

**Note:** The engine cowling panels shown in Steps 53 to 65 will not fit over the engine.

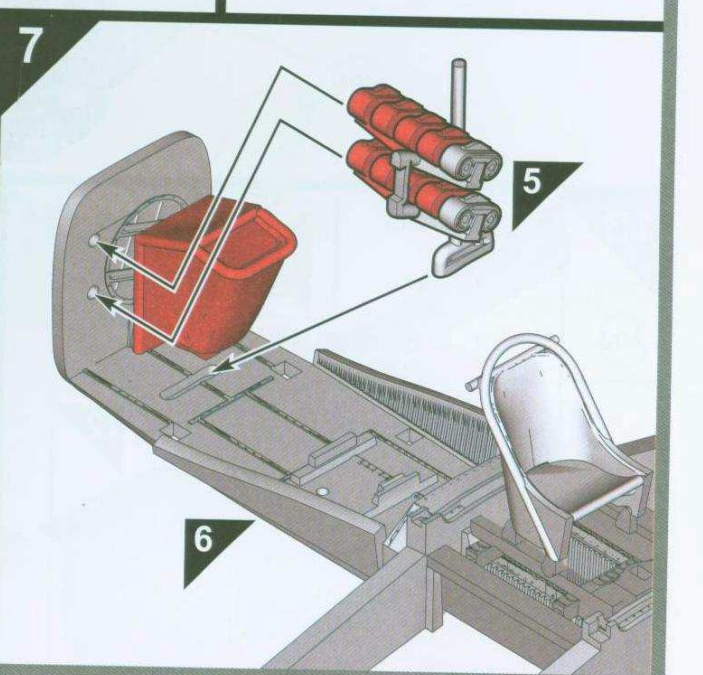
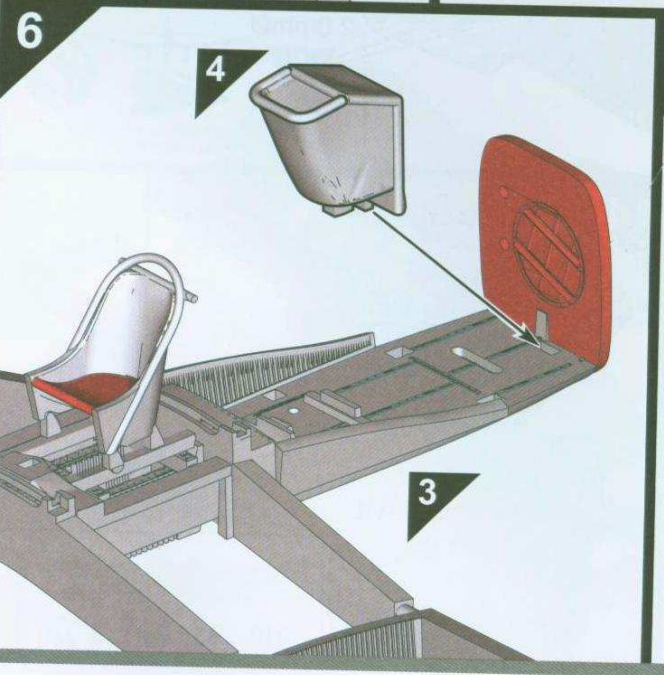
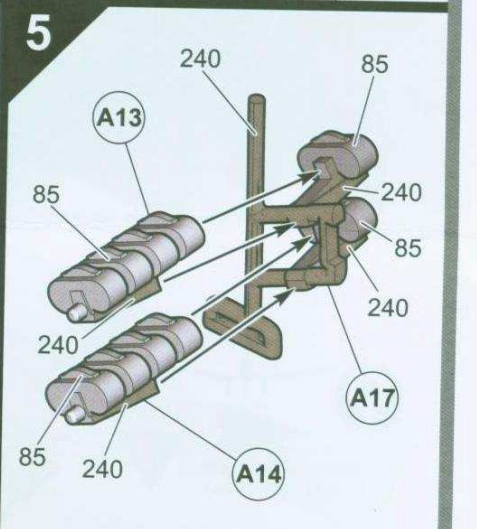
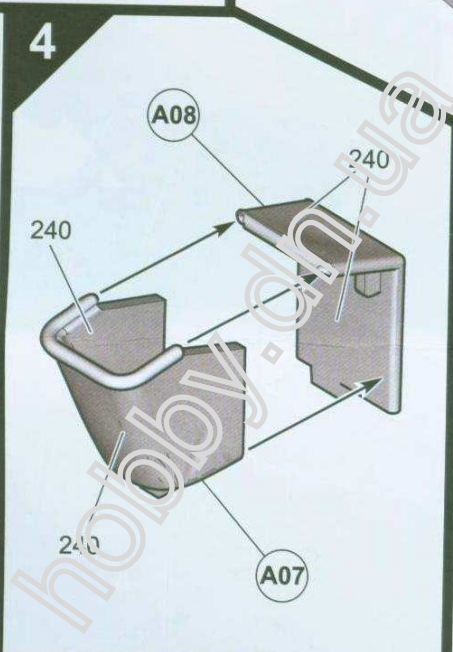
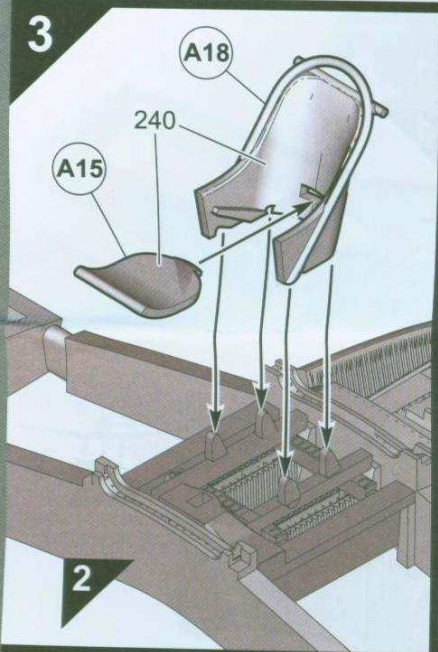
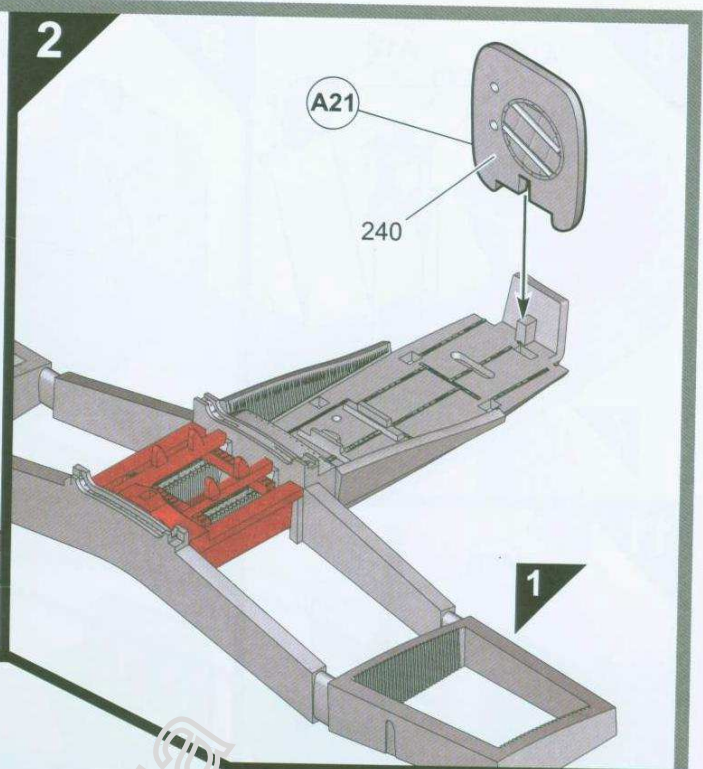
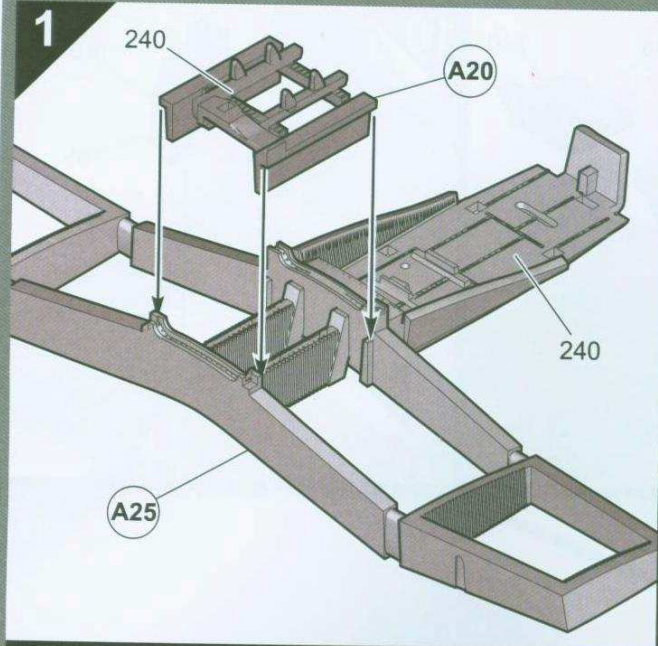

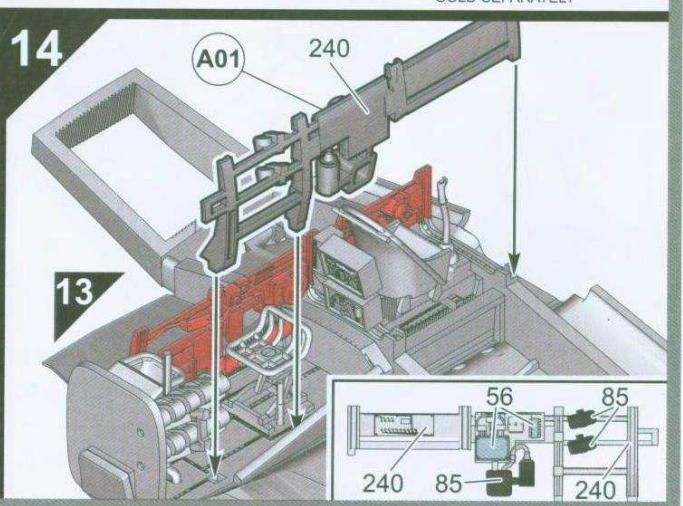
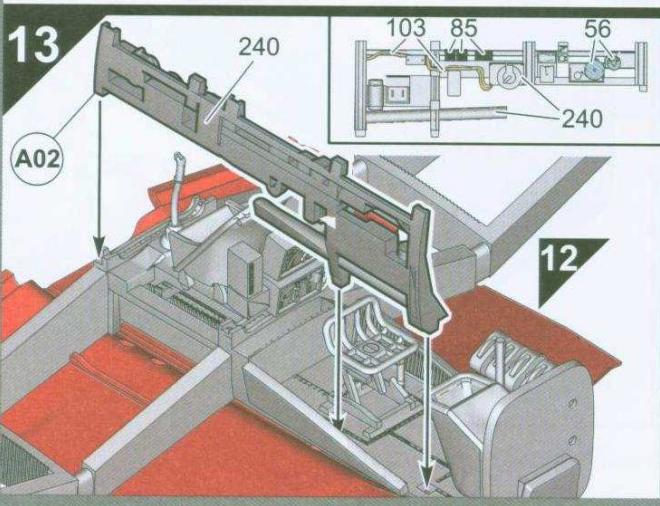
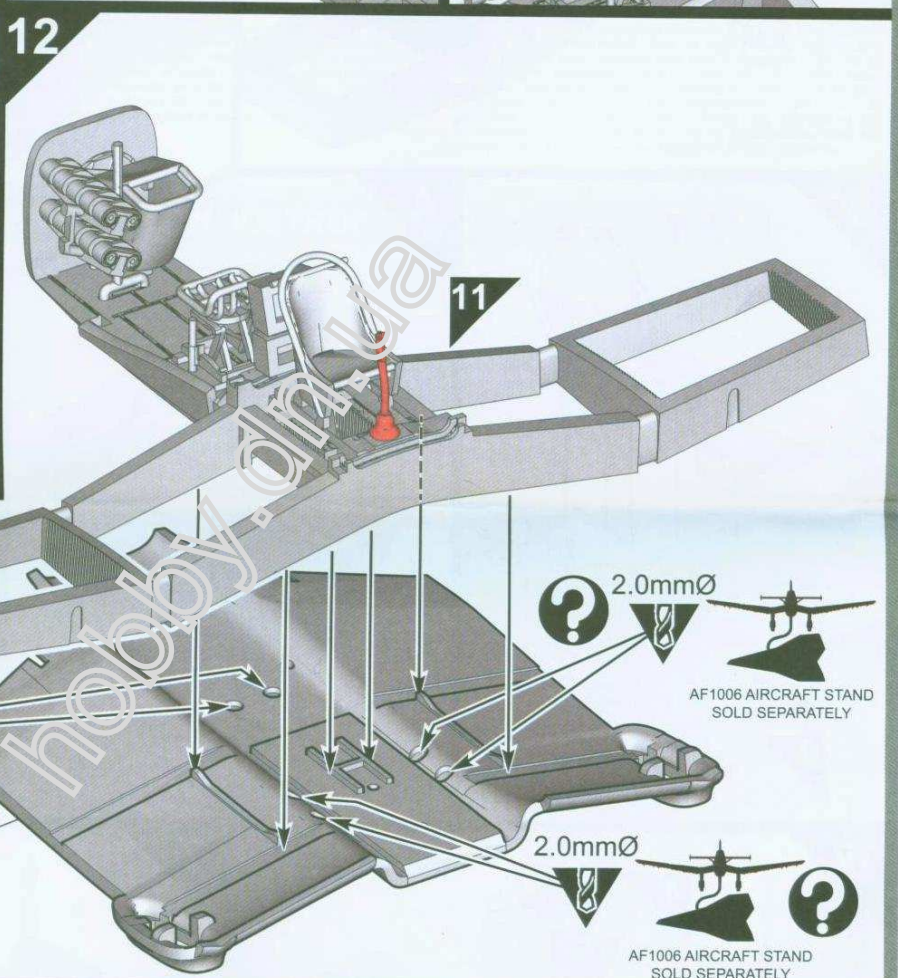
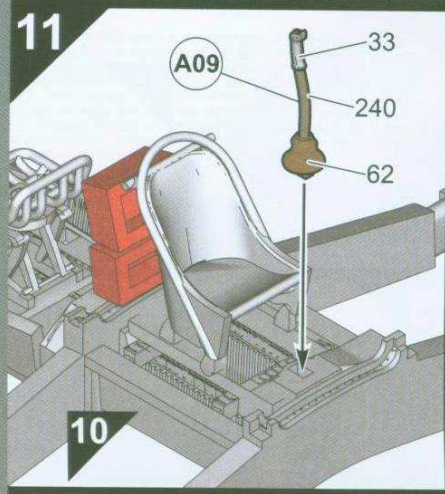
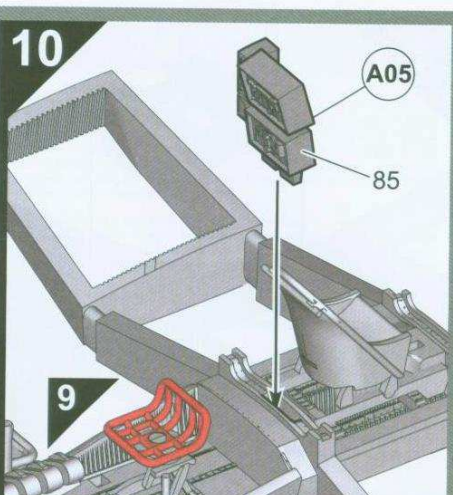
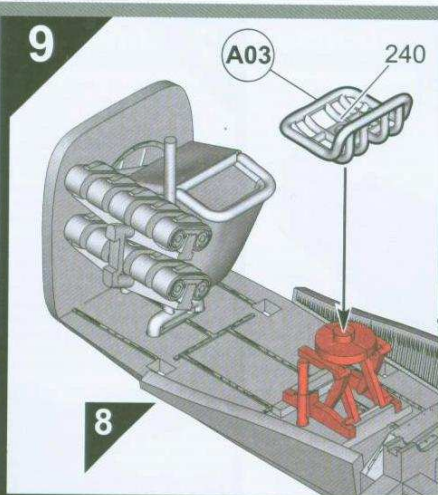
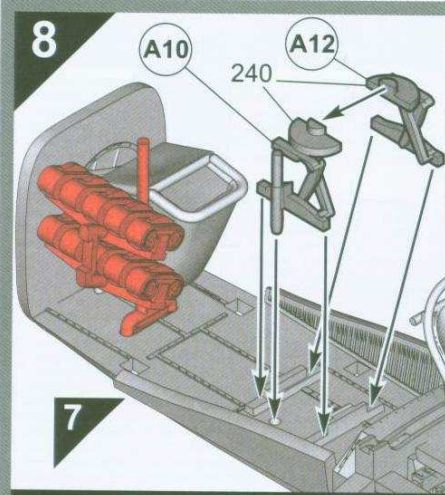

15

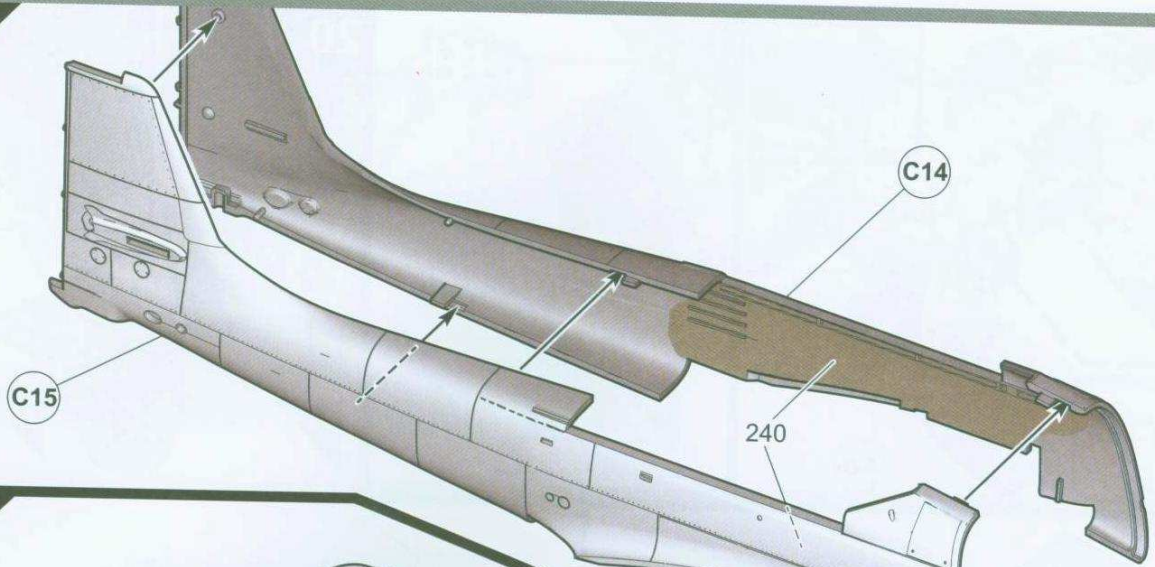

16

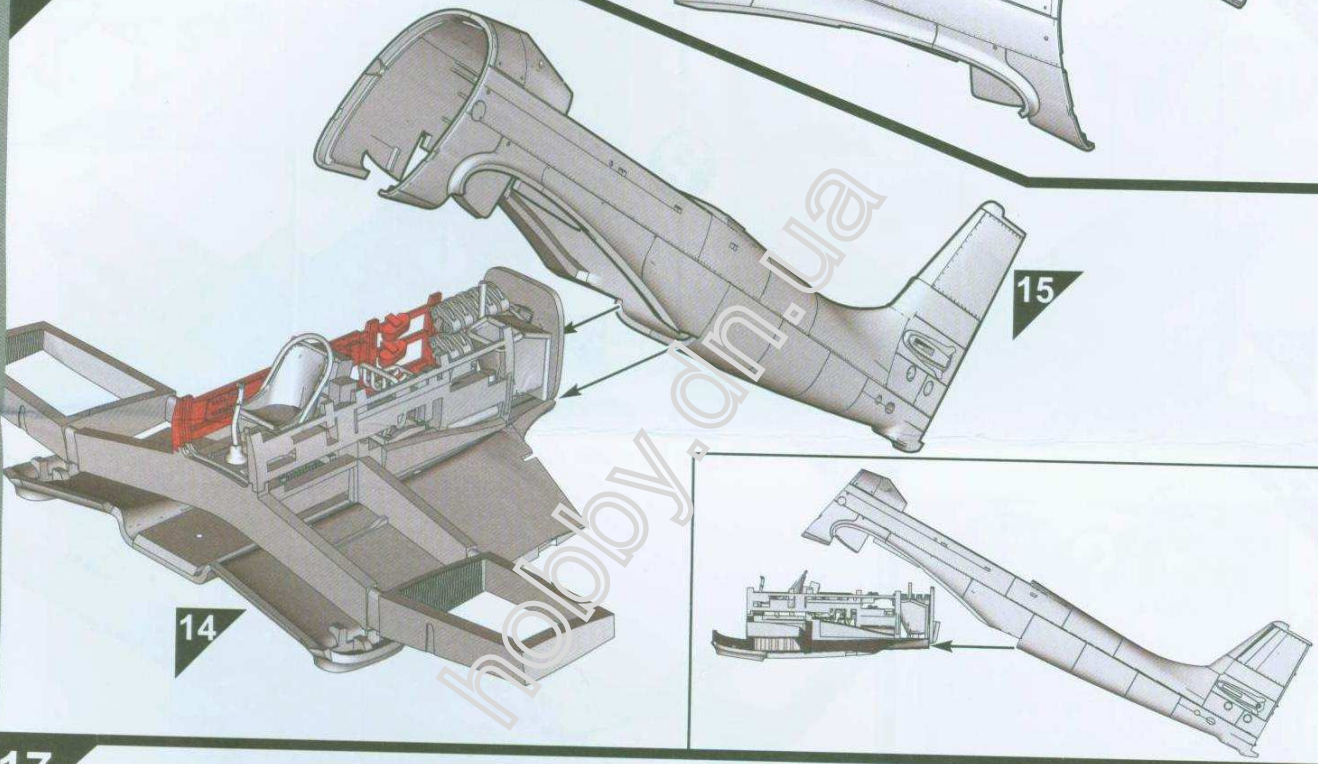

17

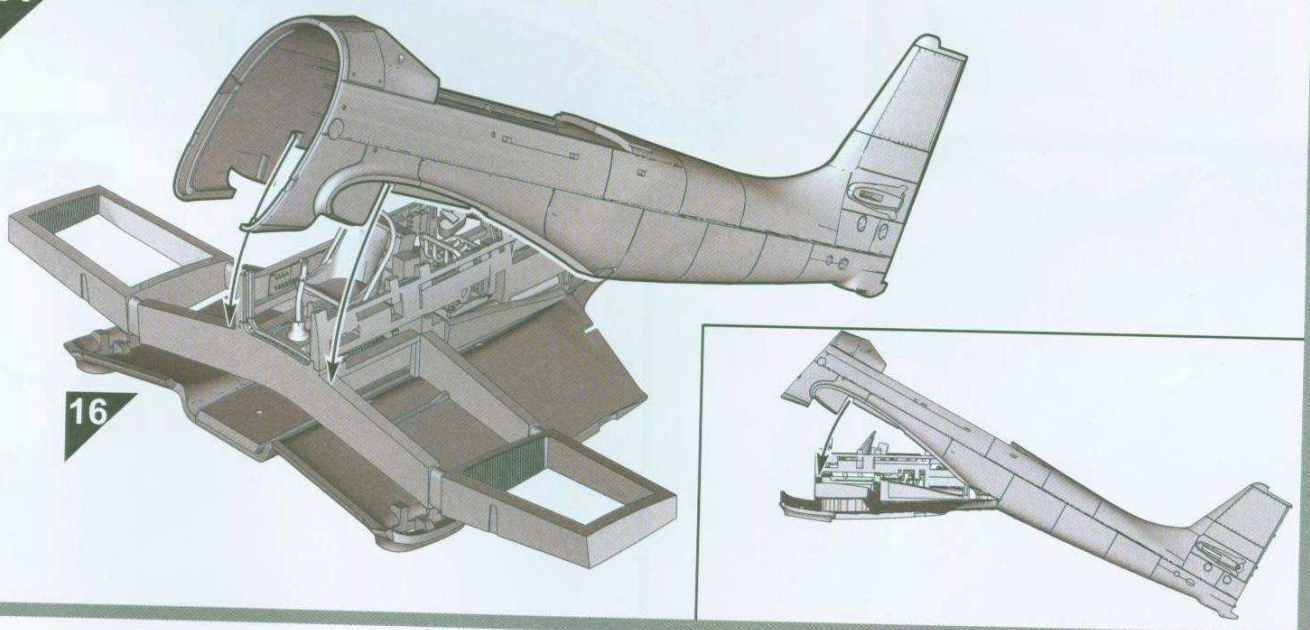

18

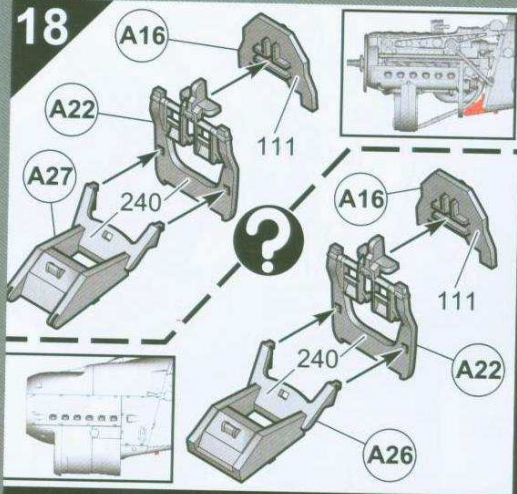

19

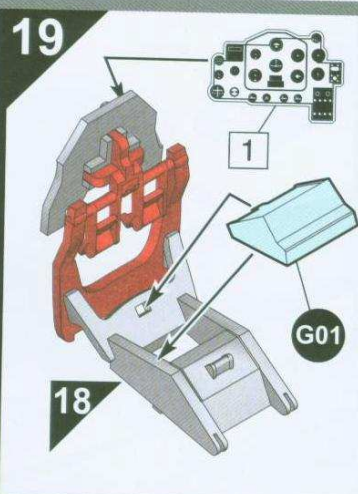

20

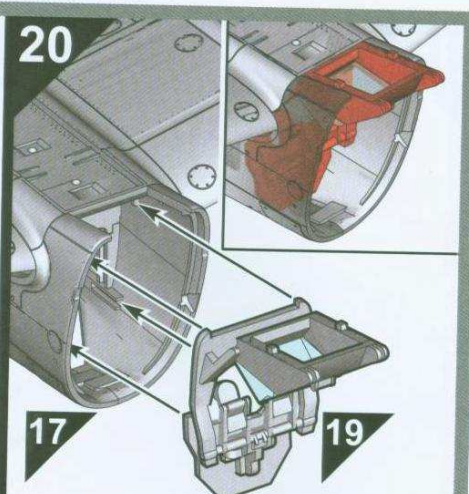

21

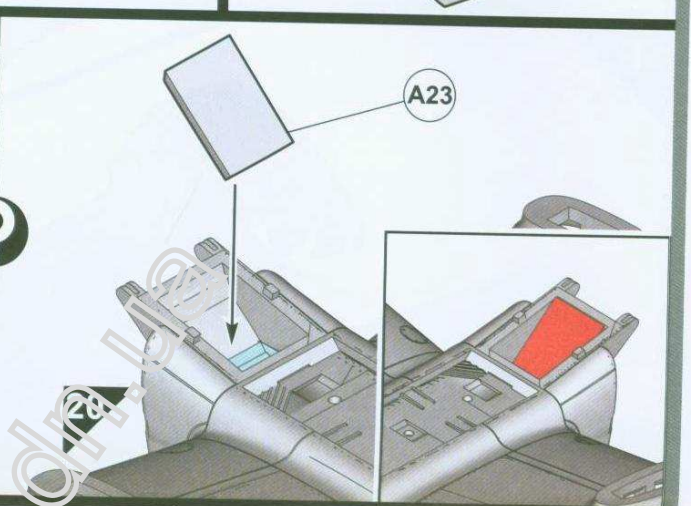
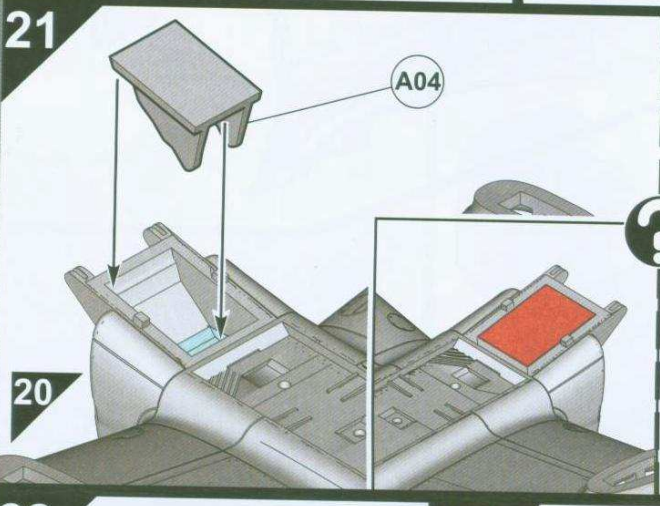

22

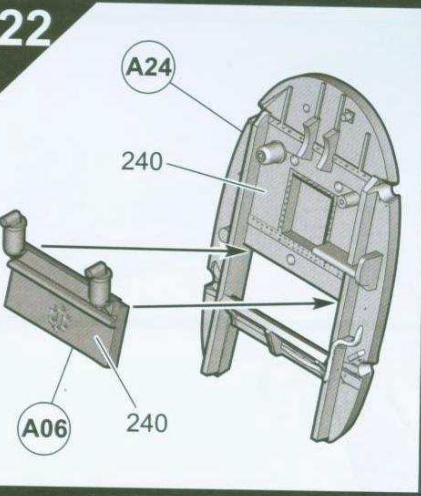

24

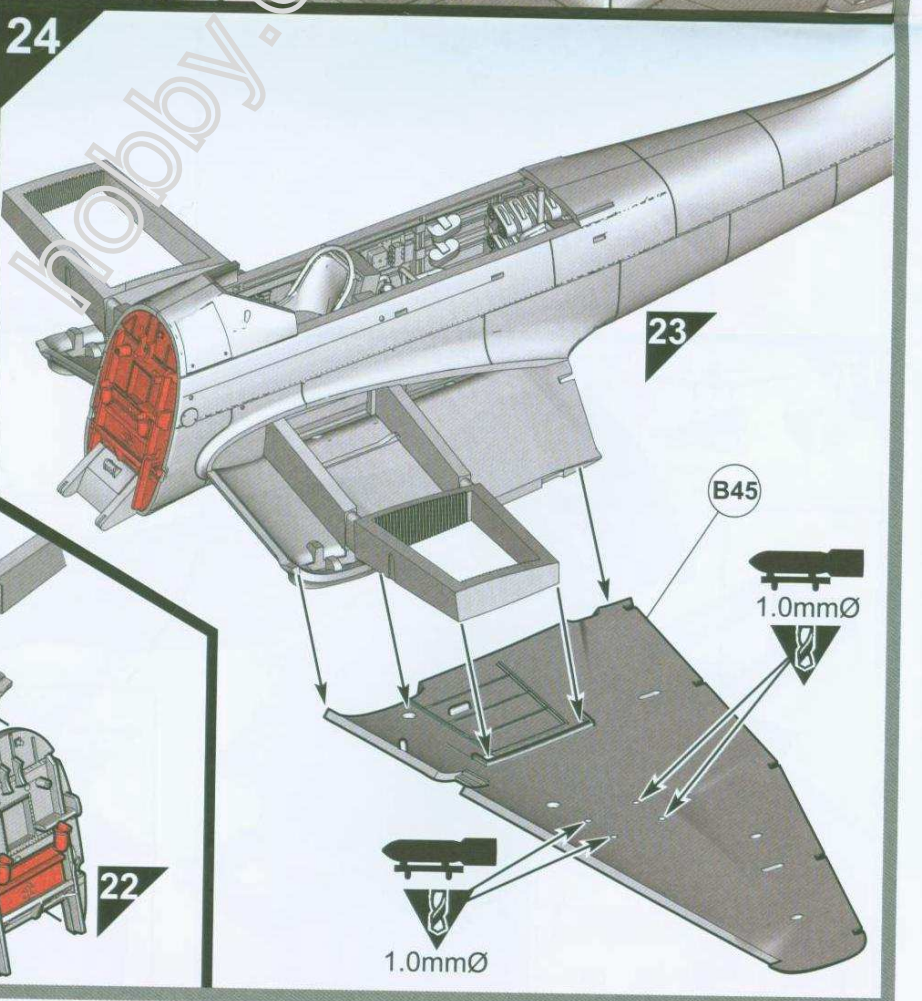

23

23

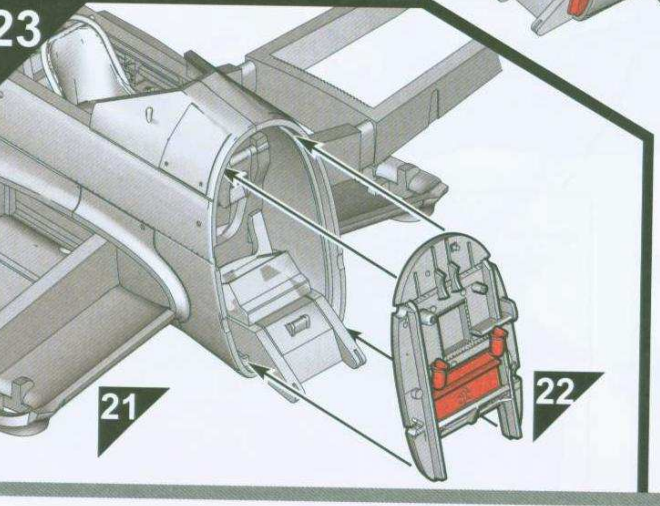

25



26

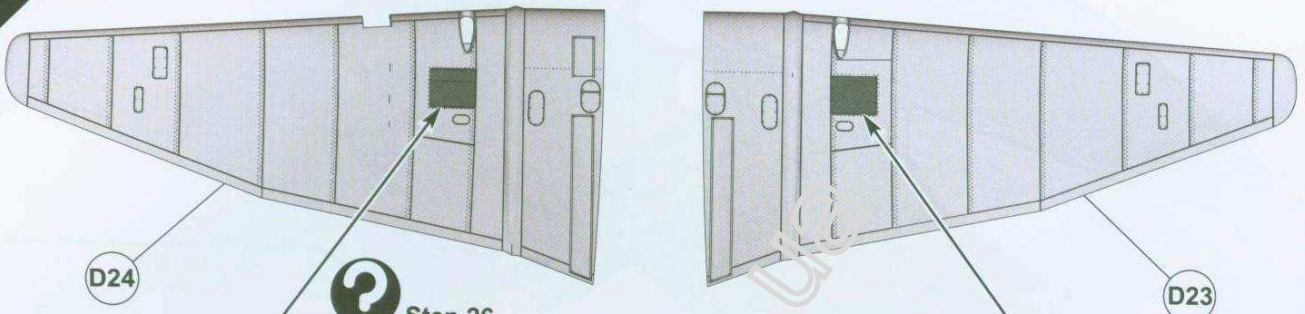

**Step 26**

Option 1: For open gun bays, cut out the access panels shown here and fit the gun breeches shown in Steps 27 and 28.

Option 2: To leave the gun bays covered do not cut out the access panels and miss out Steps 27 and 28.

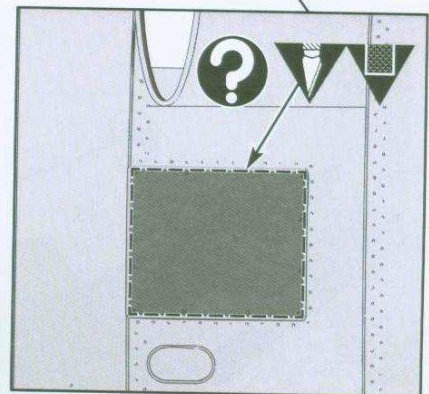
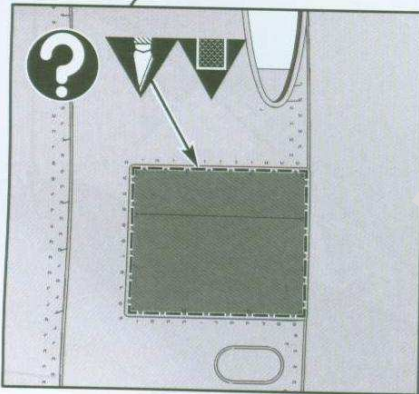

27

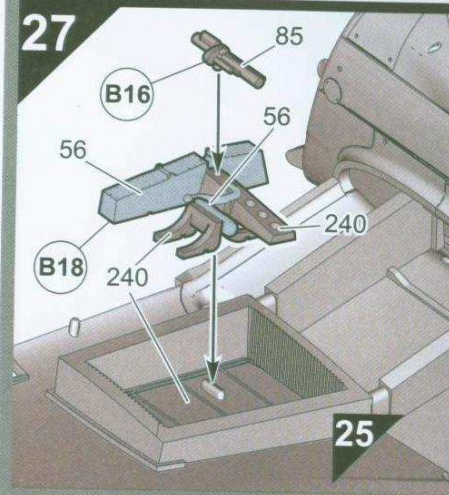

28

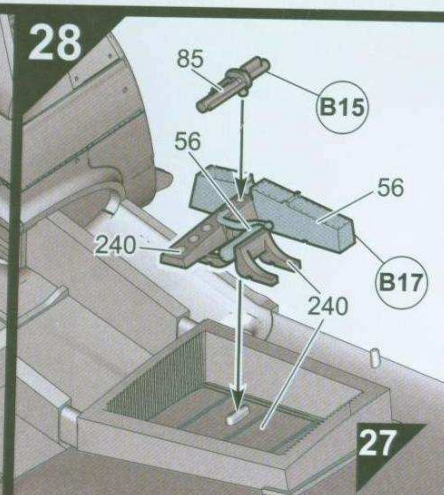

29

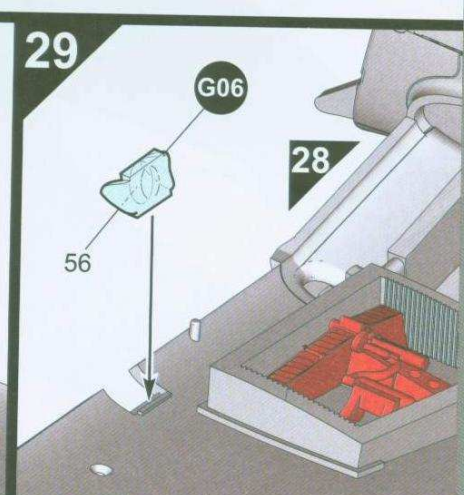

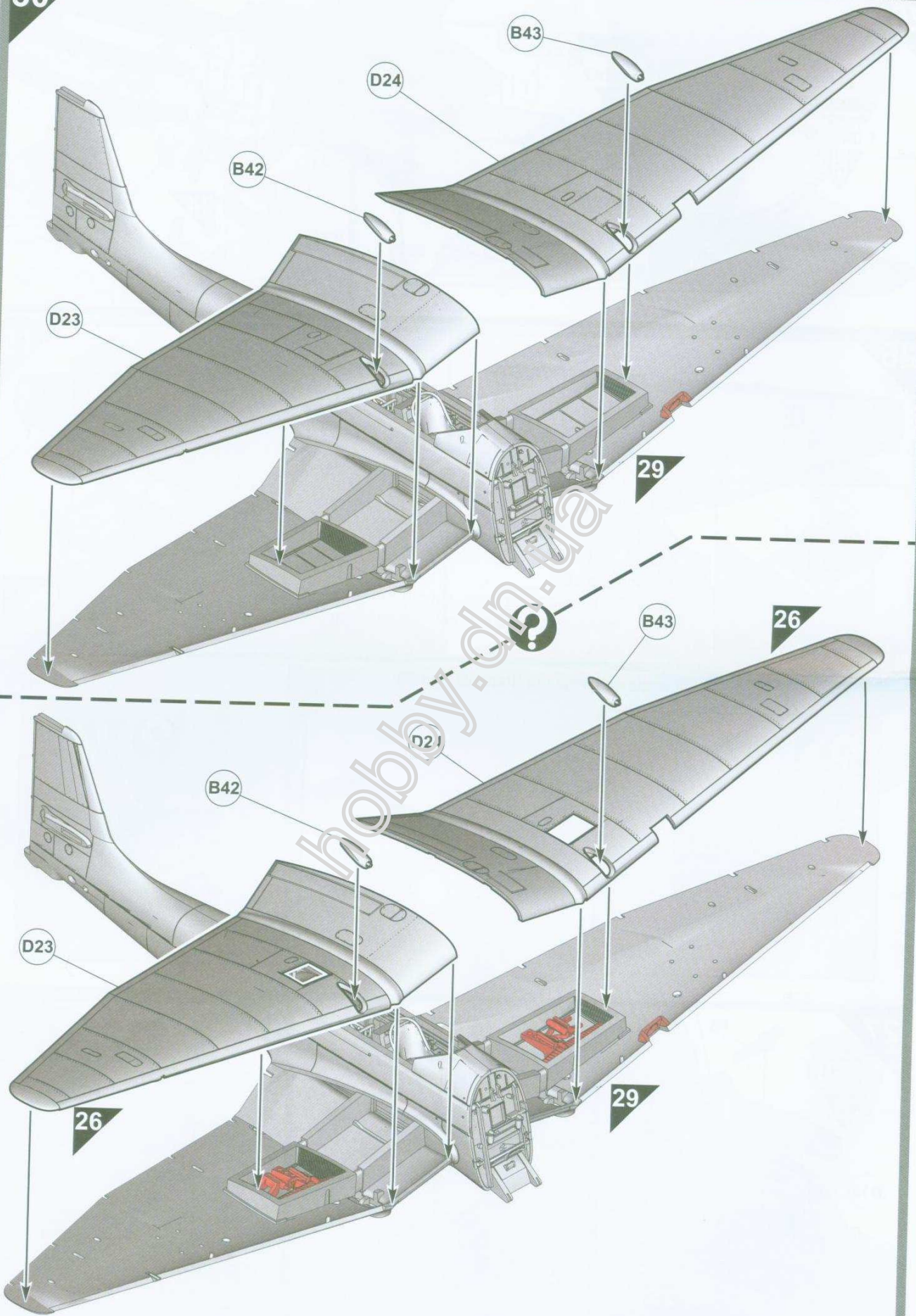



31

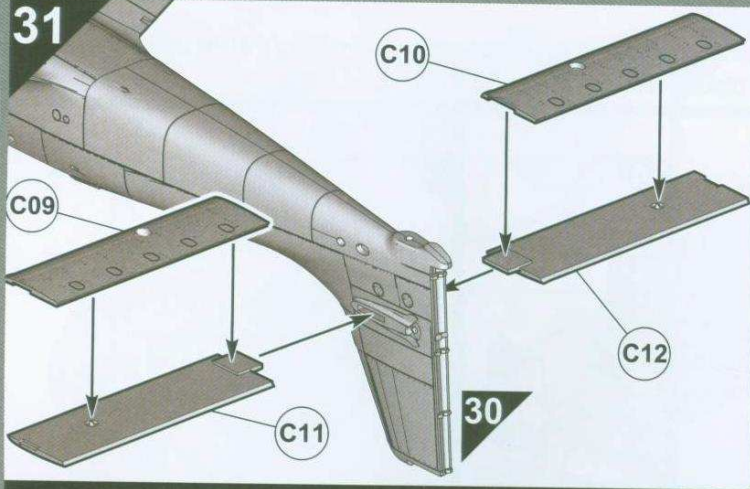

32

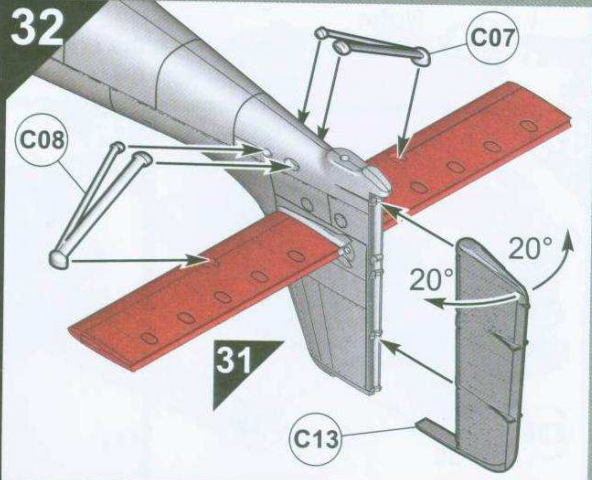

33

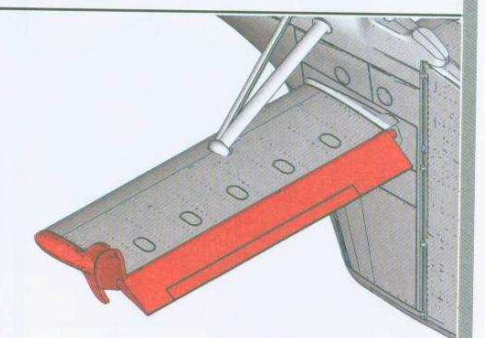
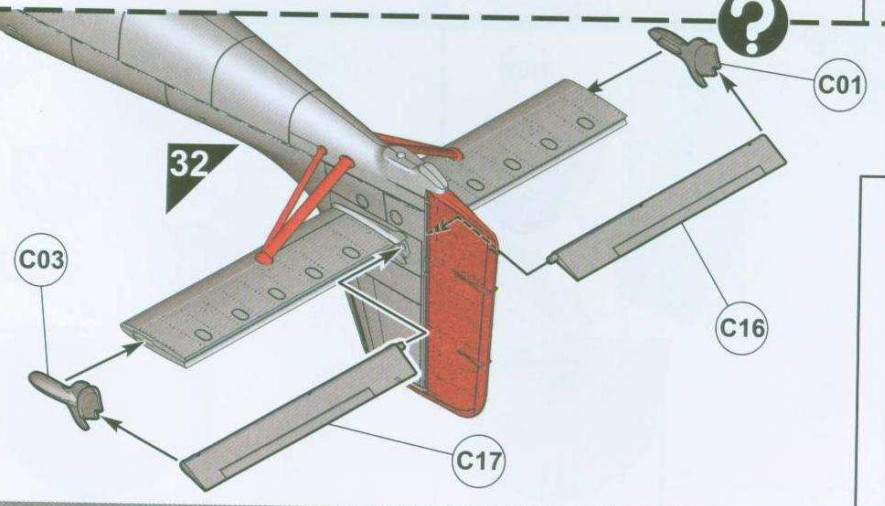
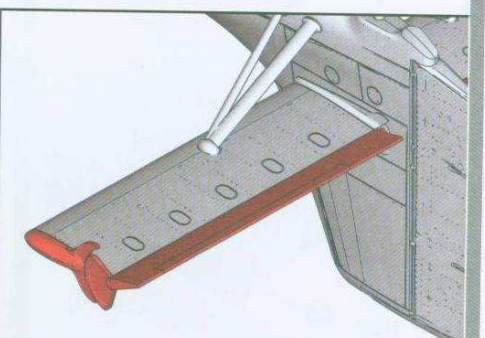
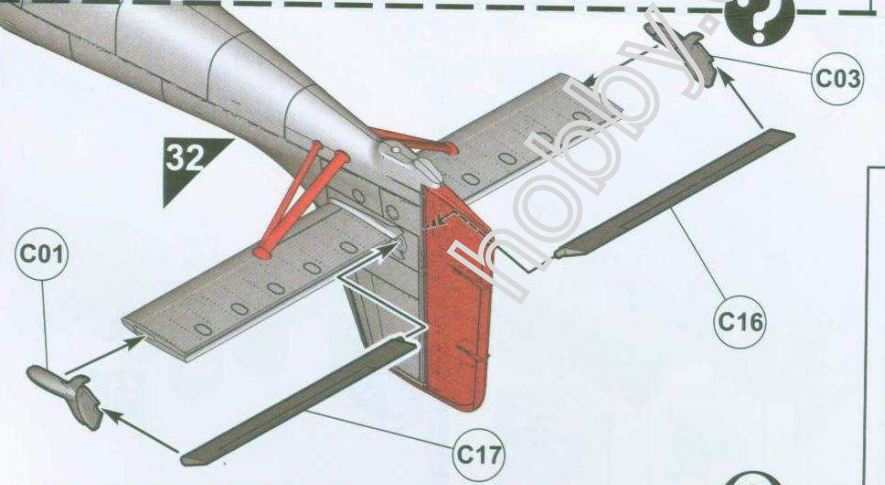
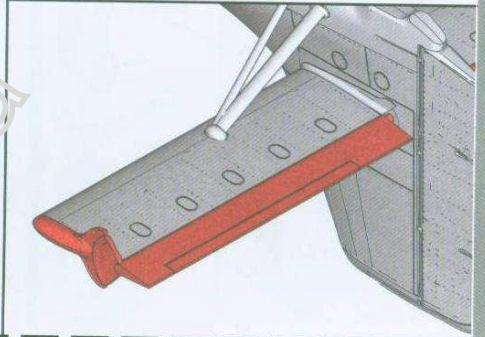
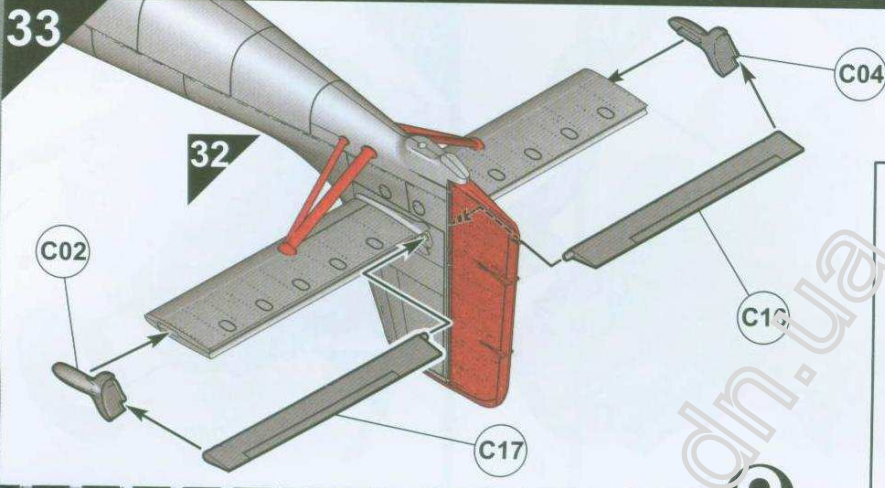



**Note:**  
 To build the model with the engine cowlings in place miss out steps 34 to 52 go straight to Step 53.  
 To build the model with the engine in place miss out steps 53 to 65.

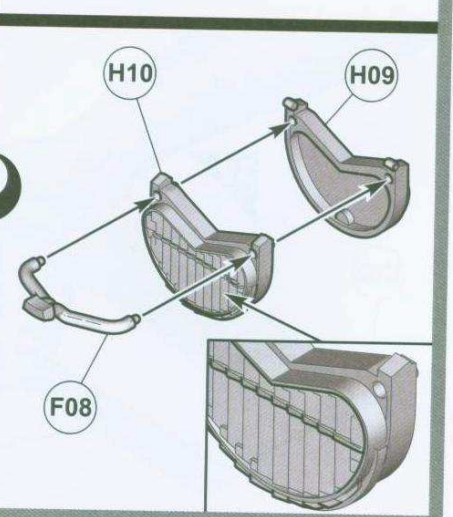
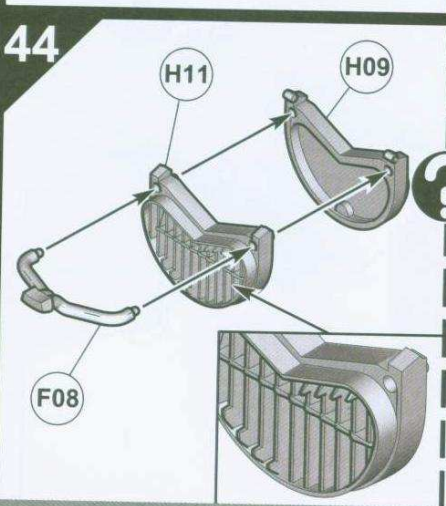
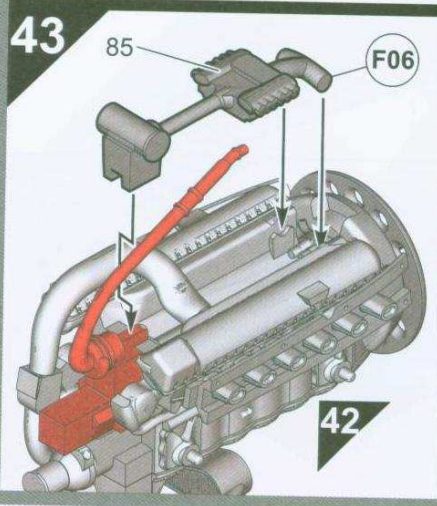
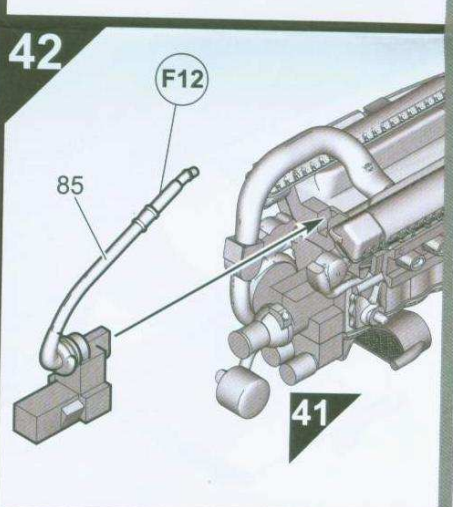
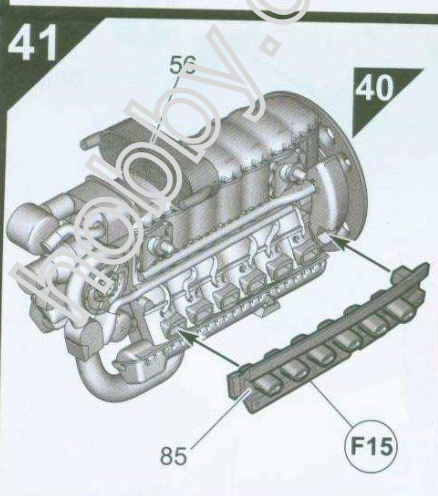
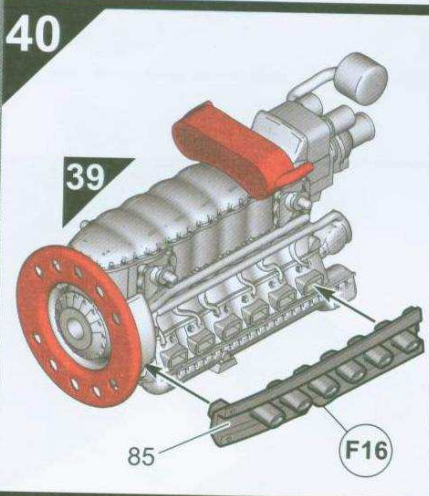
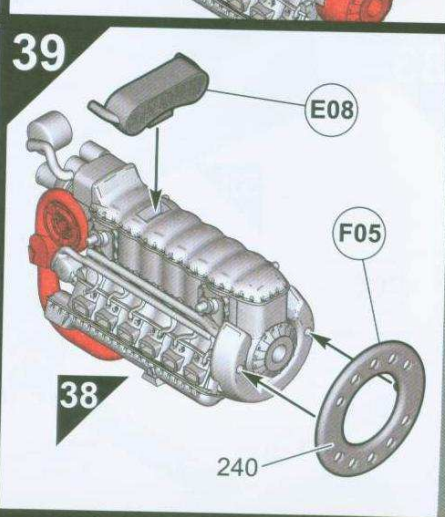
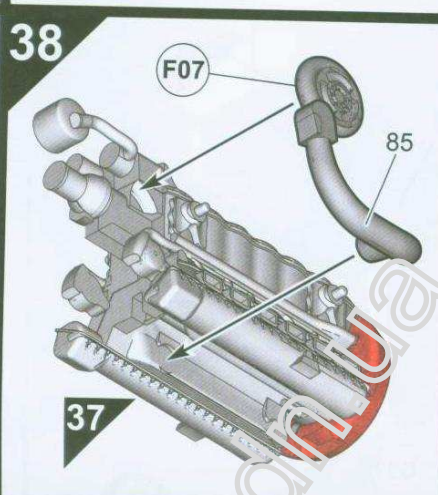
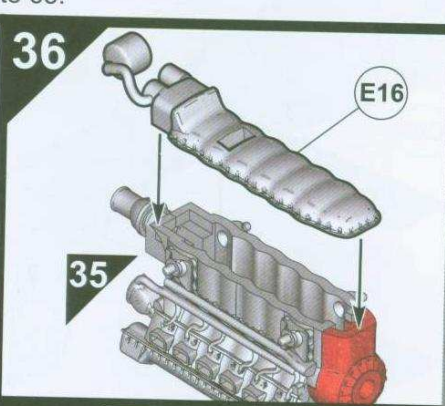
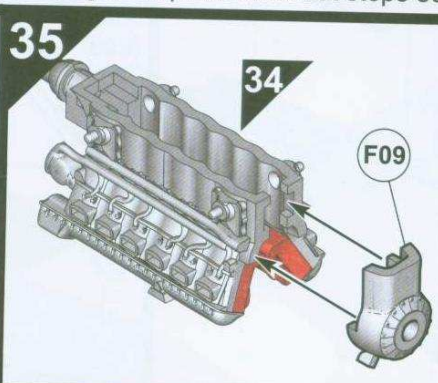
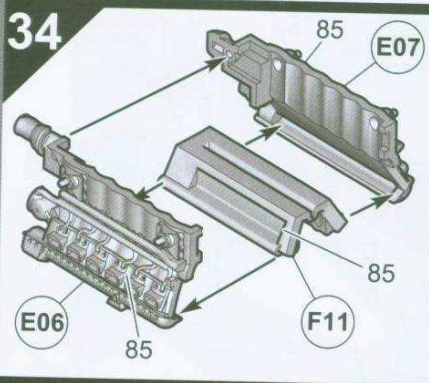

45

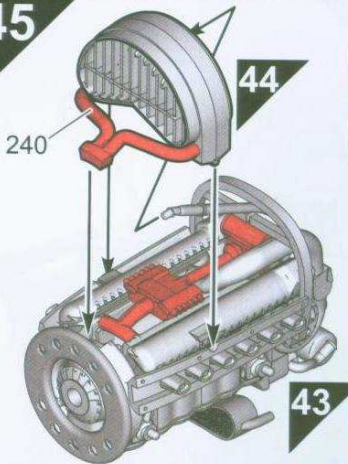

46

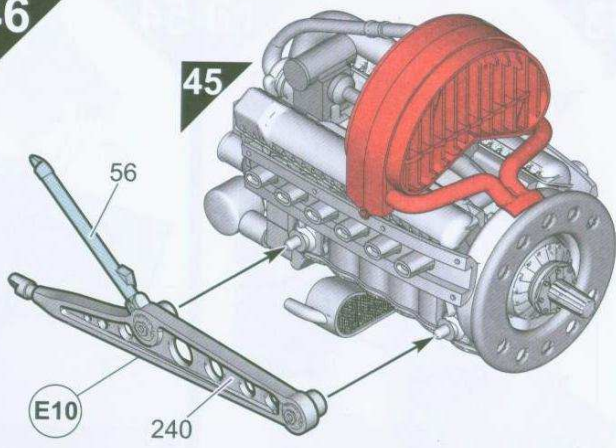

47

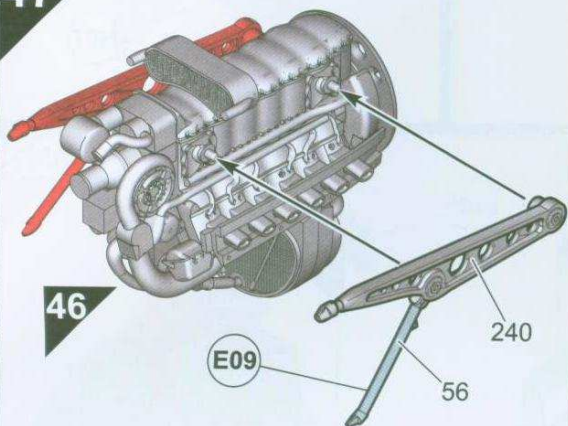

48

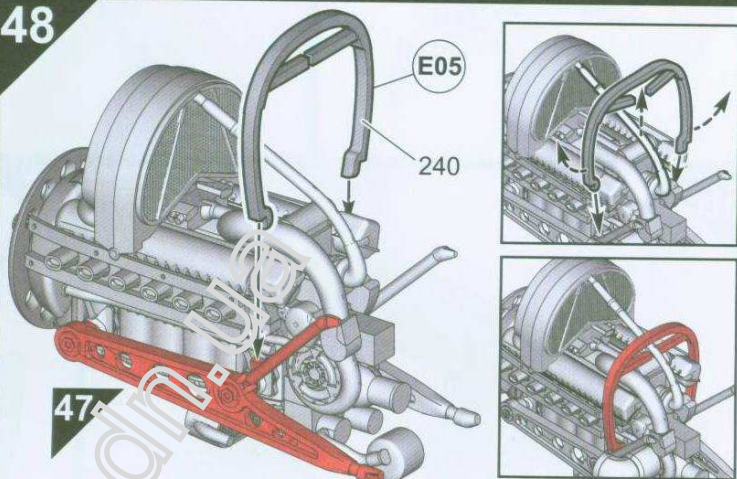

49

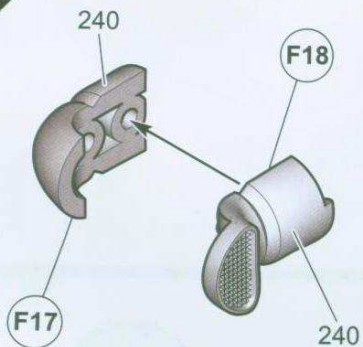

50

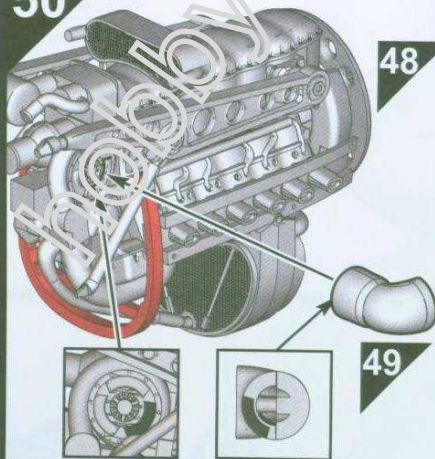

51

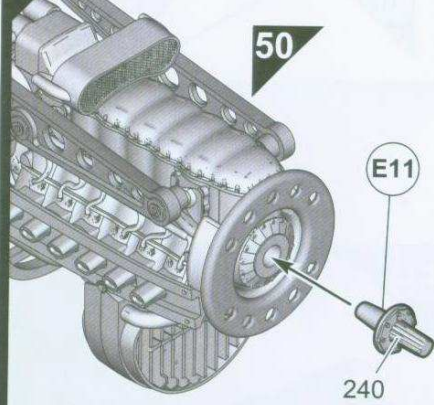

52

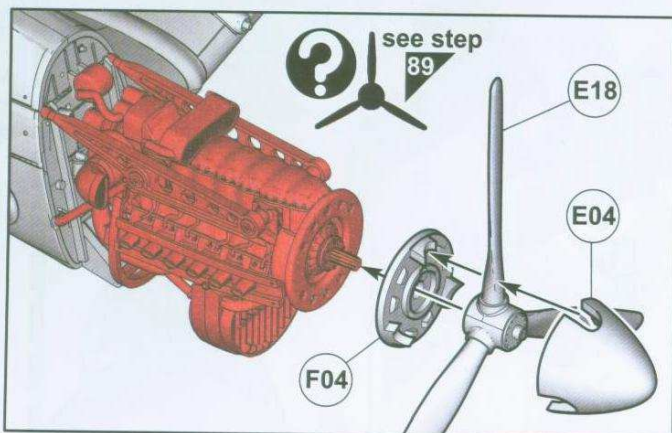
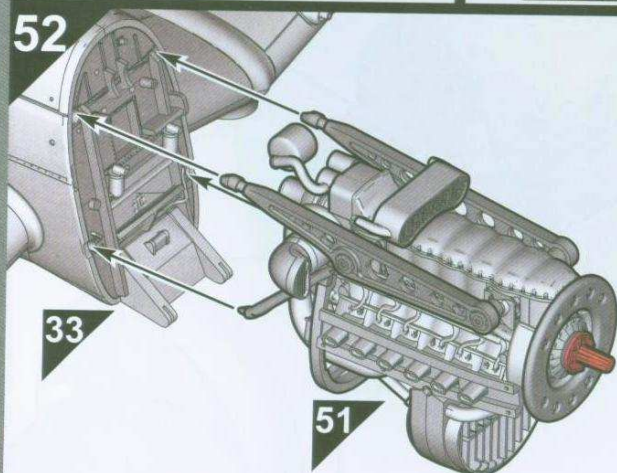

53

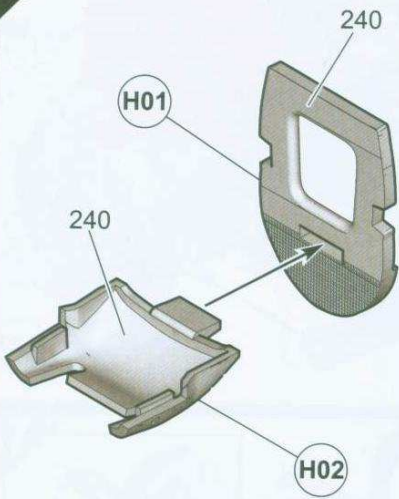

54

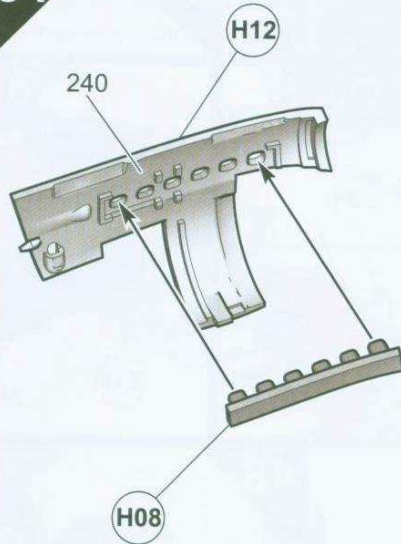

55

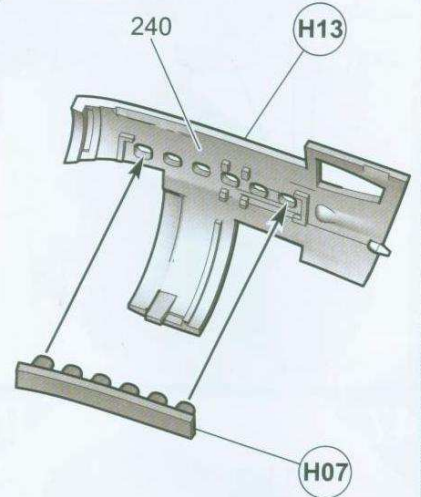

56

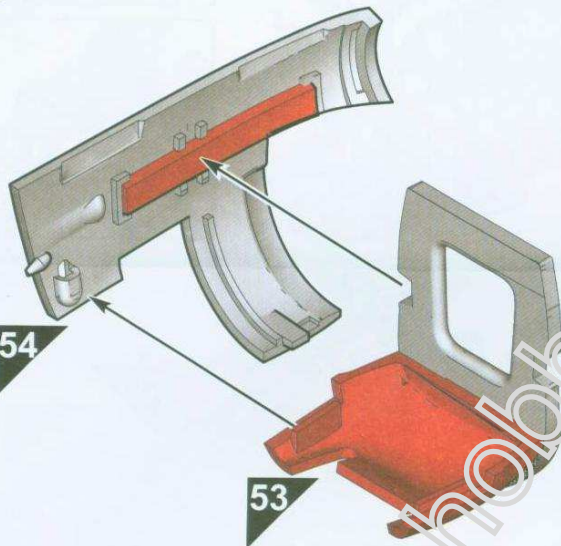

57

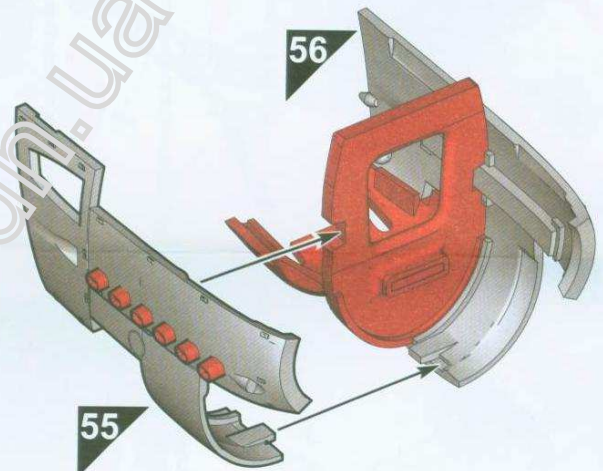

58

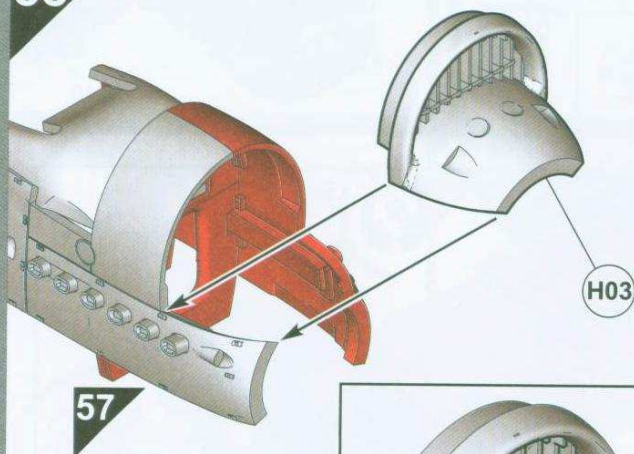

?

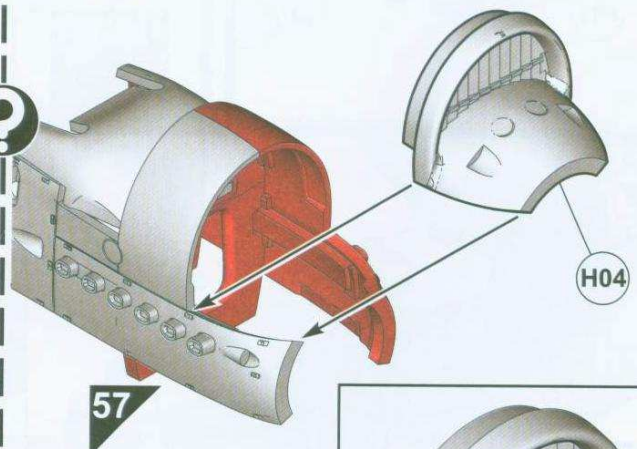

59

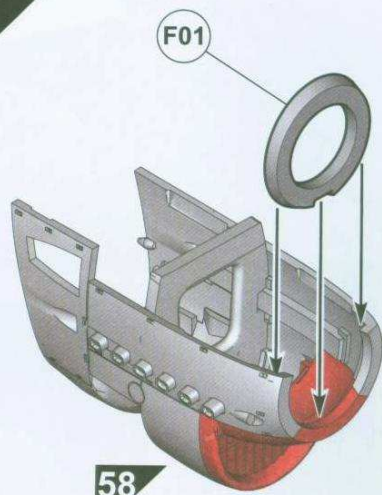

58

60

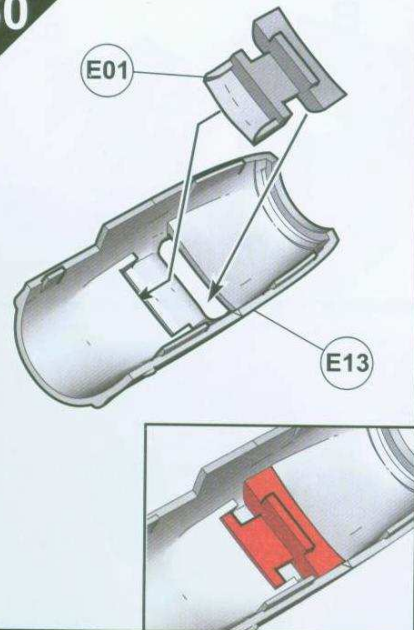

E13

61

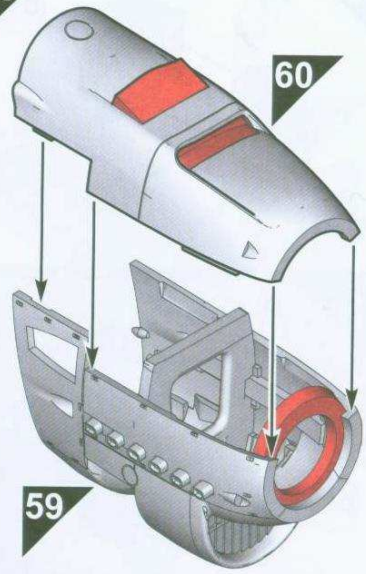

59

62

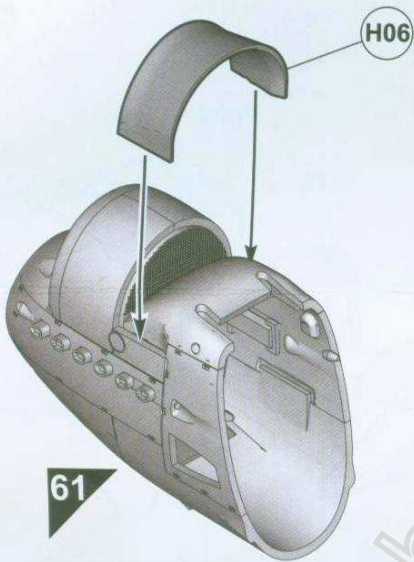

61

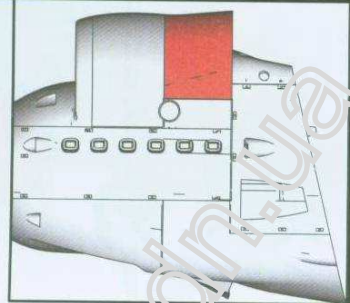

63

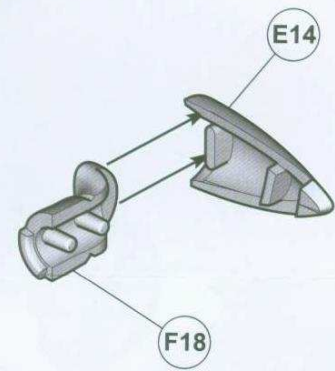

F18

64

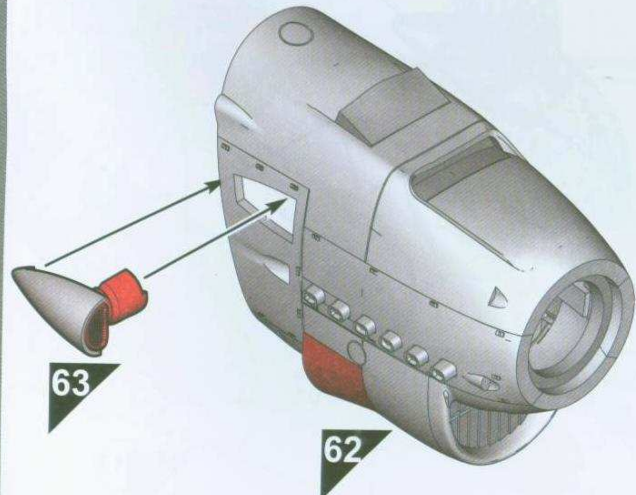

63

62

65

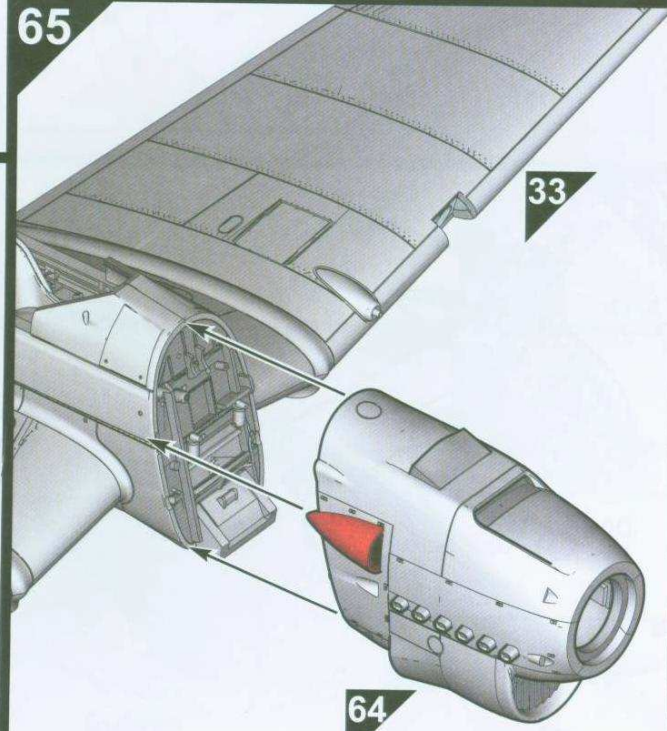

33

64

66

A

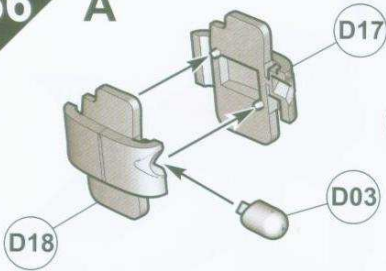

B

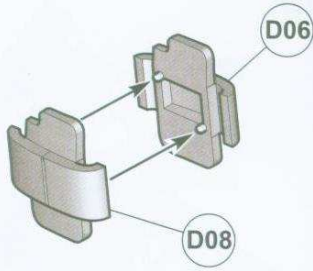

67

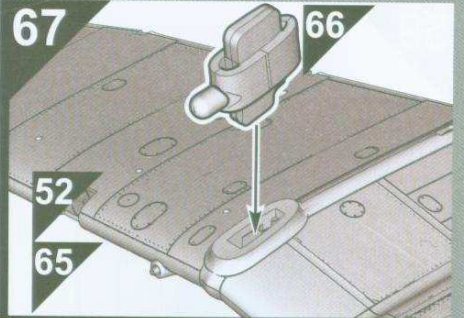

68

A

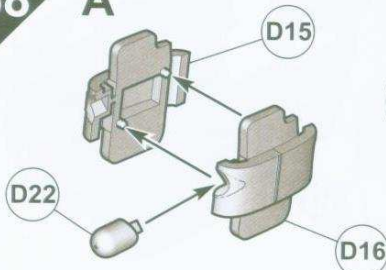

B

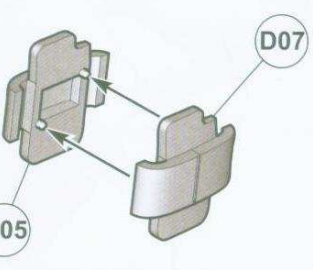

69

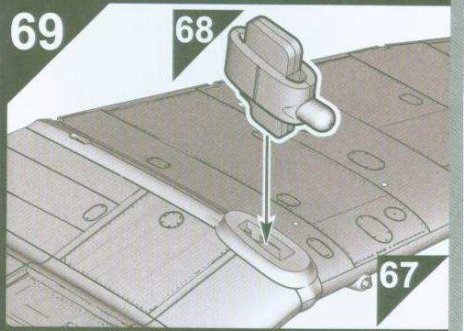

70

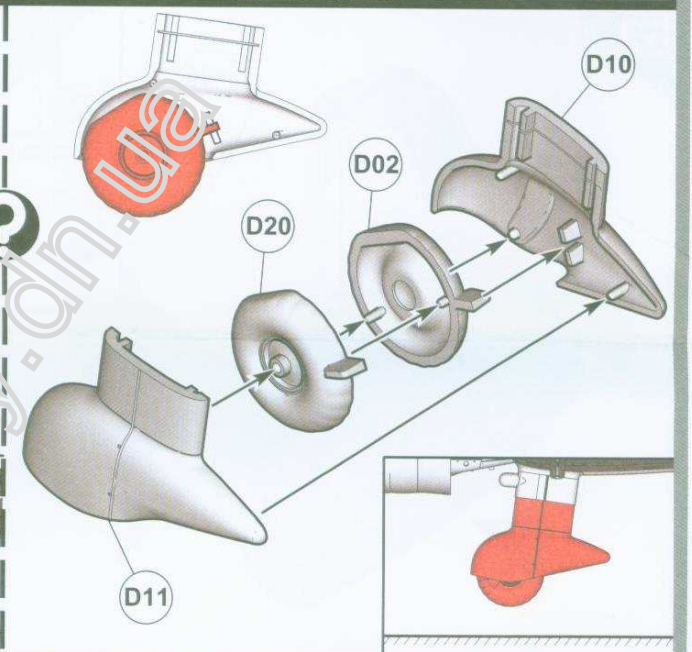
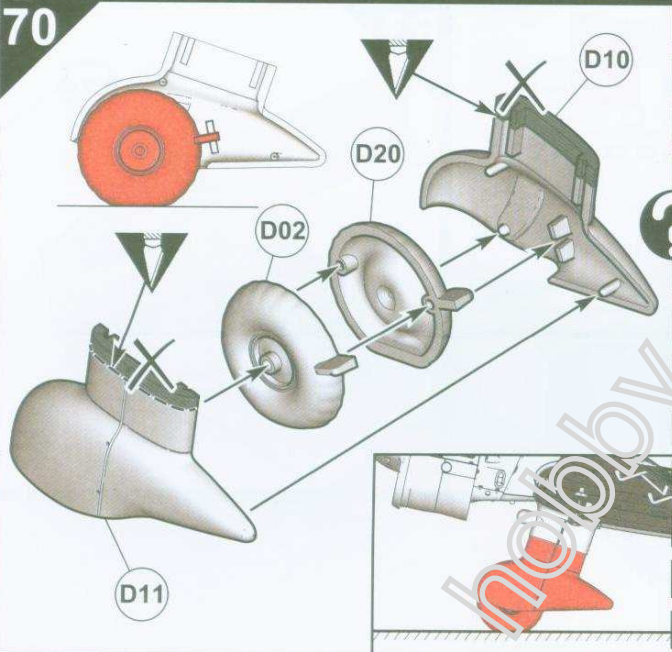

71

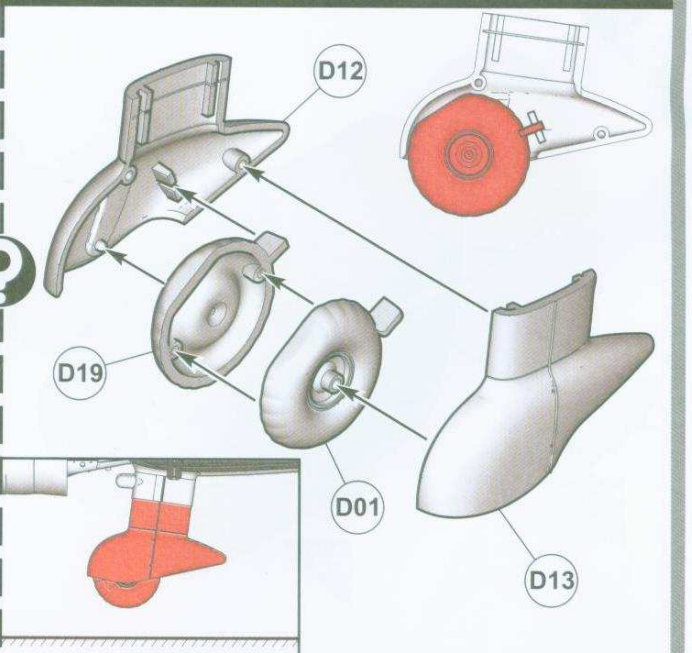
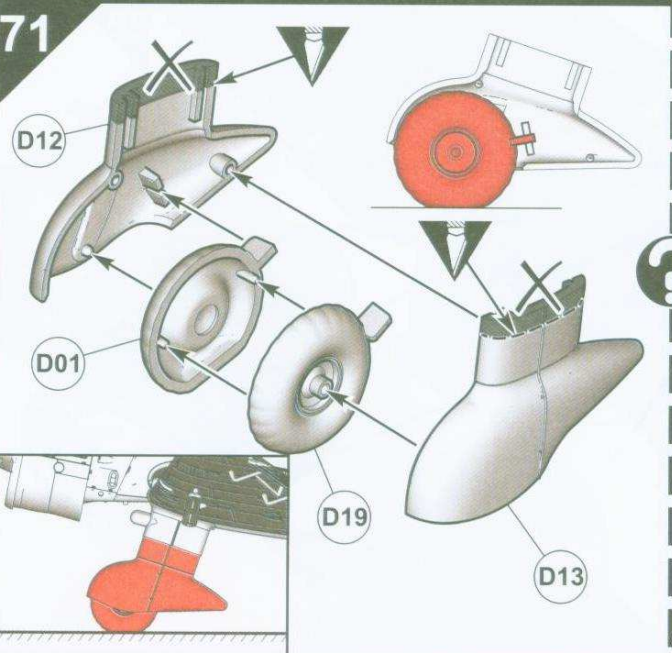

72

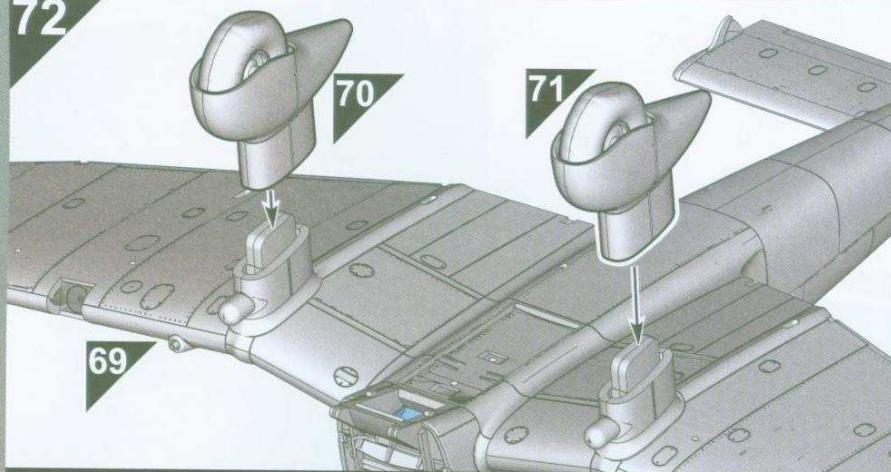

73

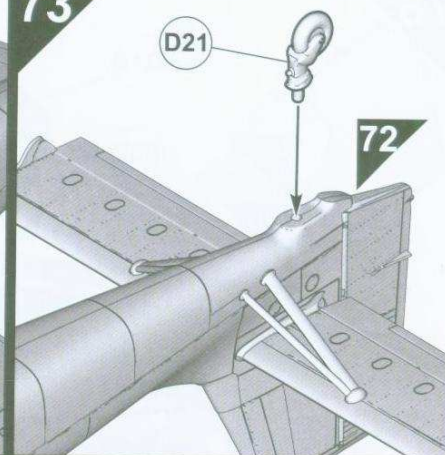

74

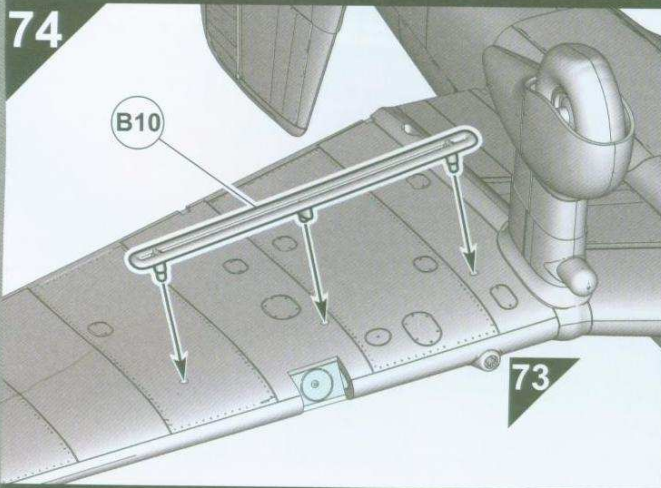

75

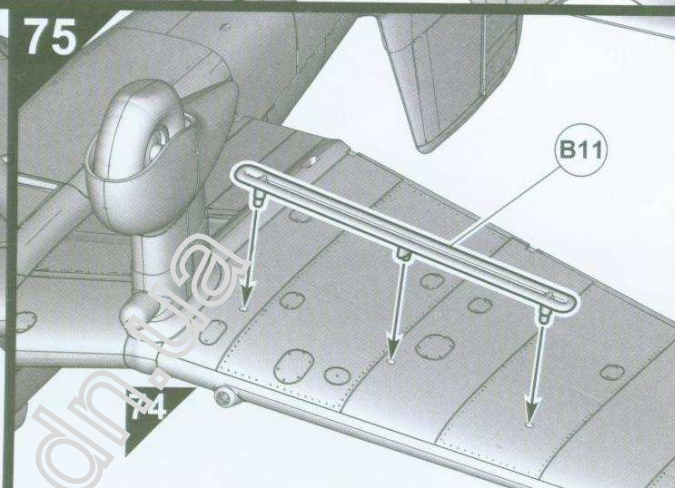

76a

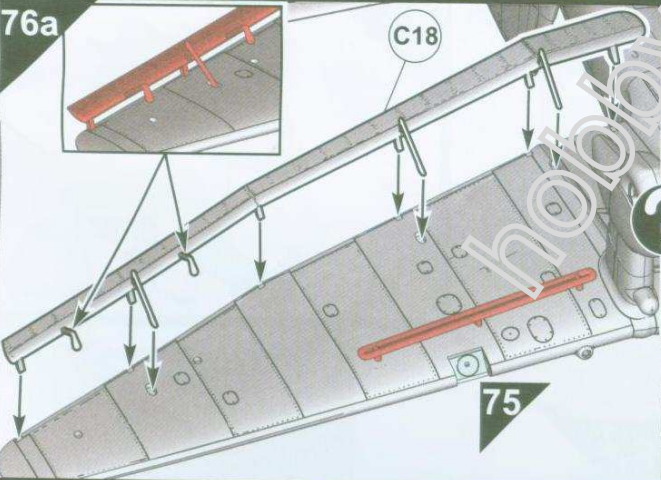

76b

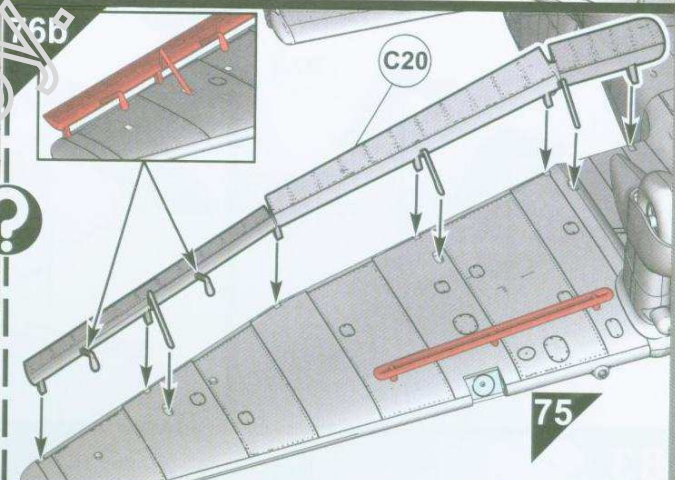

77a

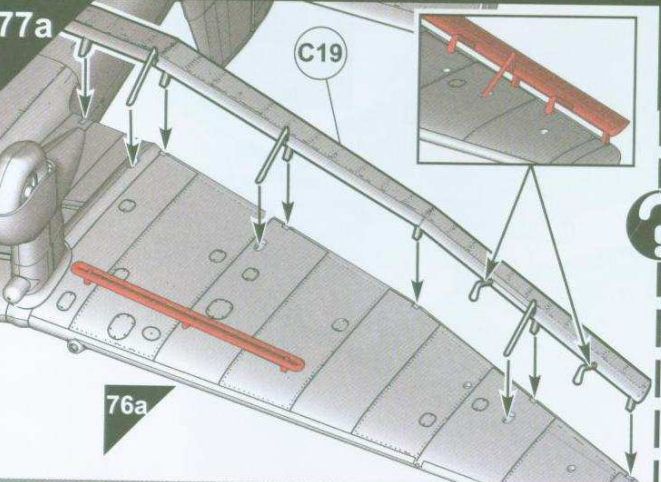

77b

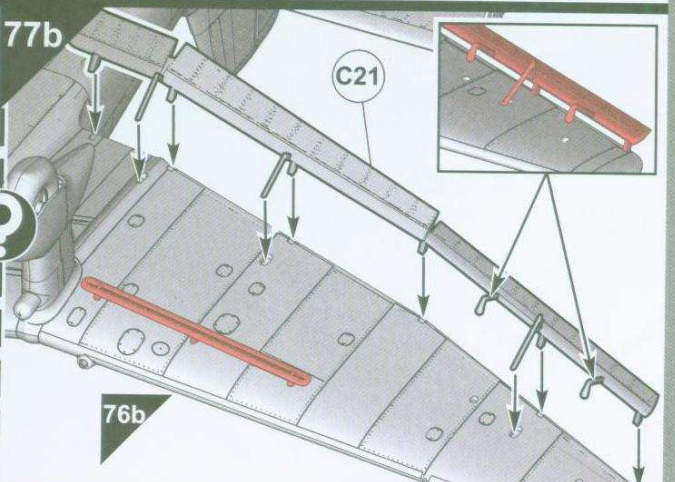

78

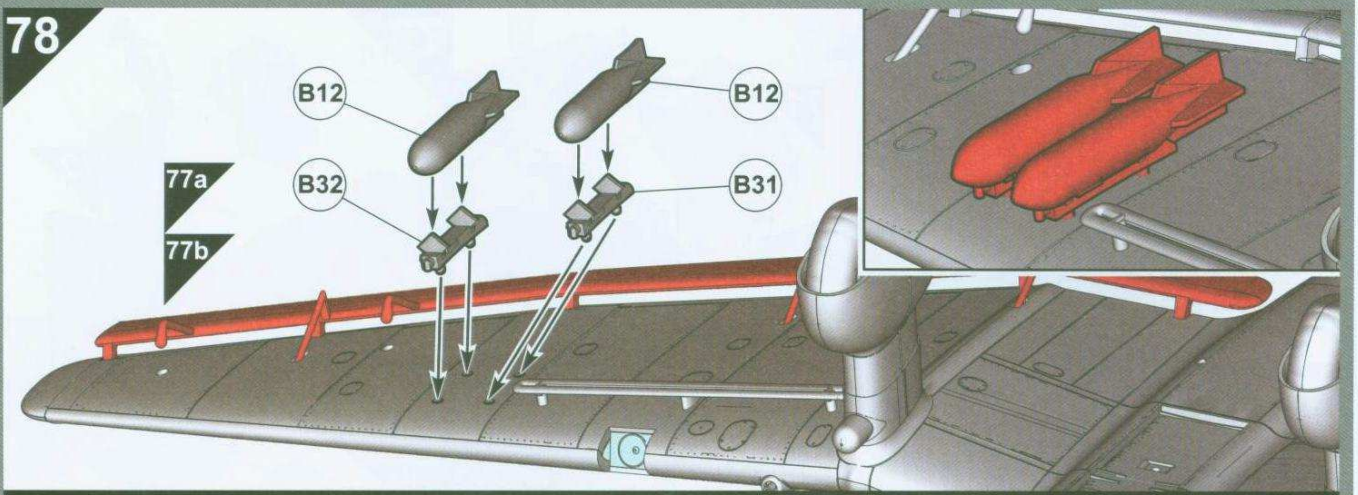

79

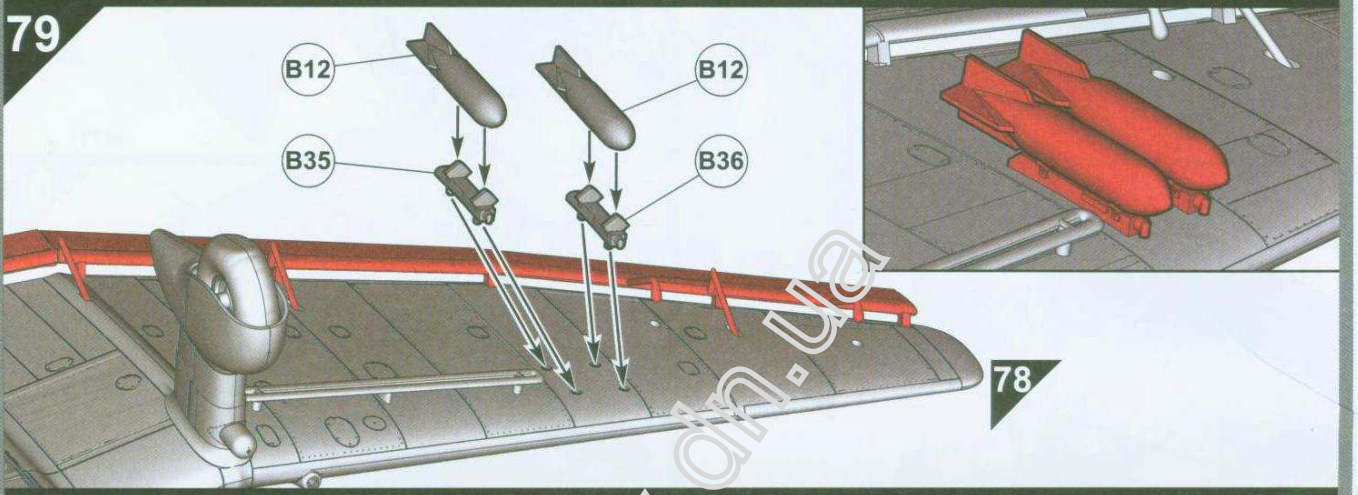

80

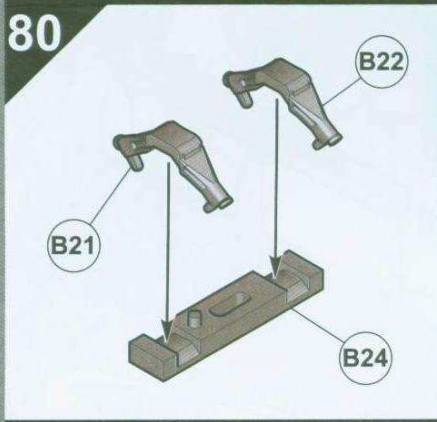

81

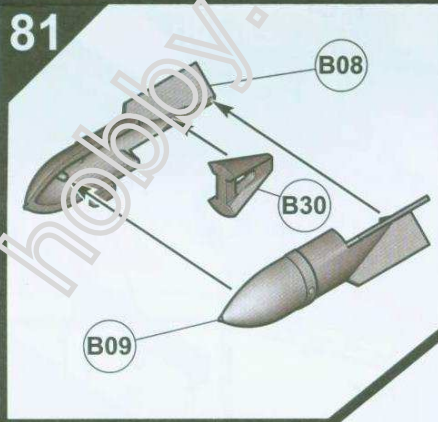

82

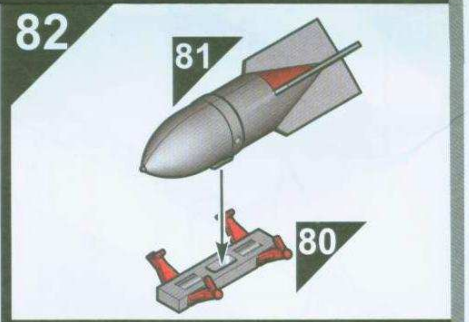

83

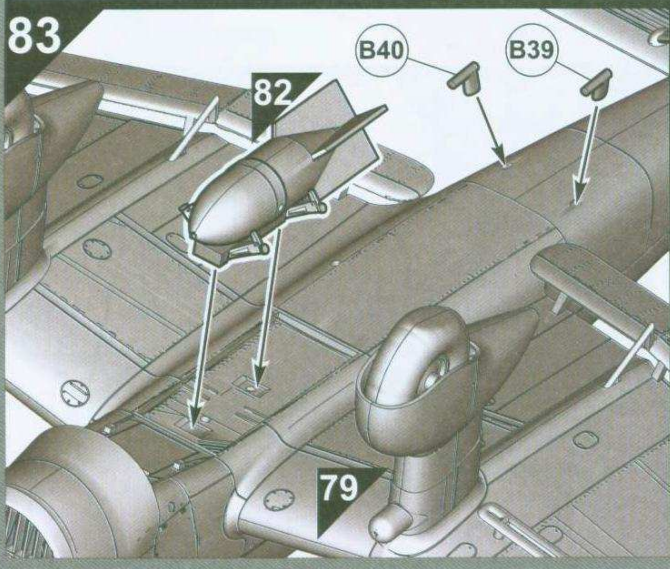

84

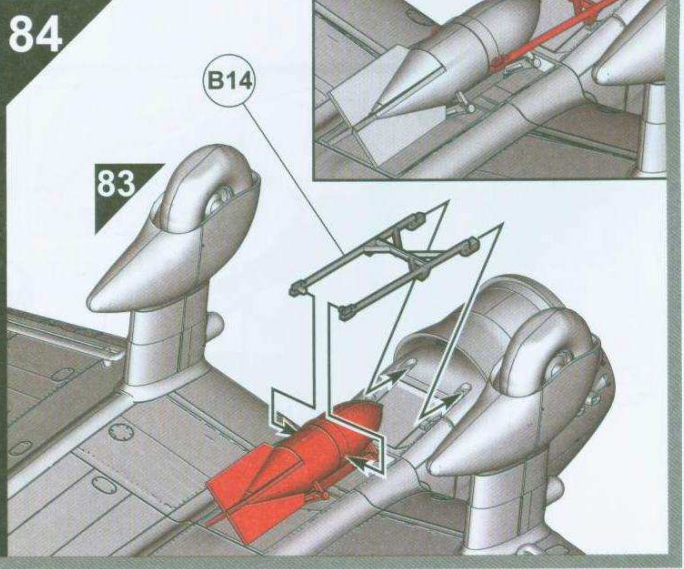



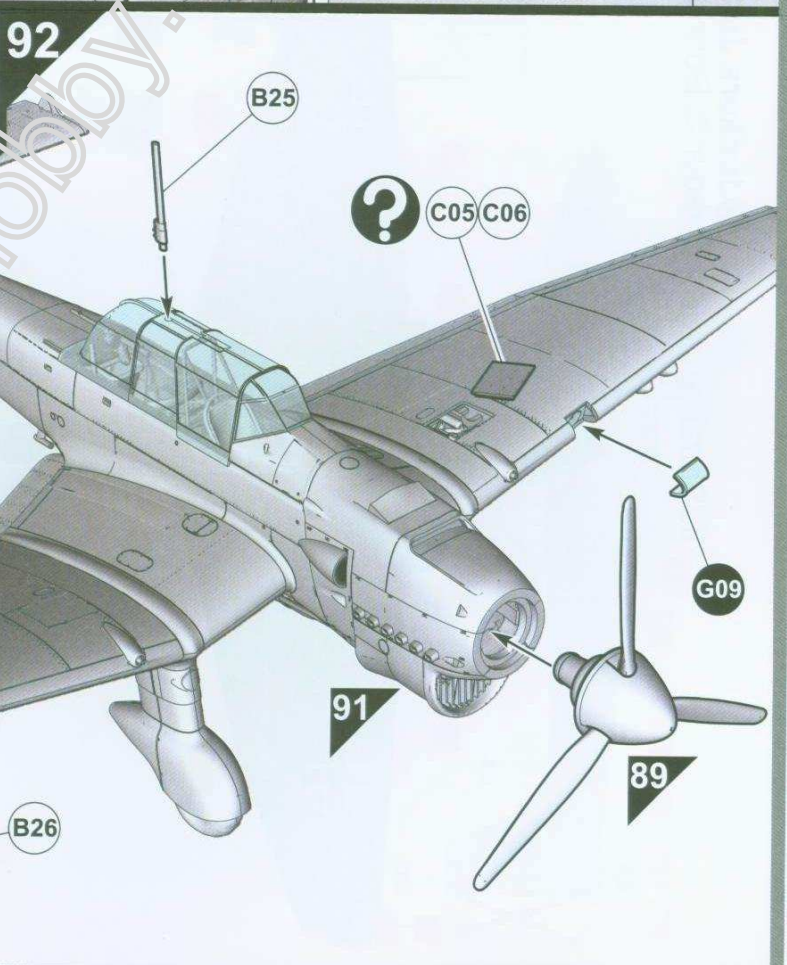
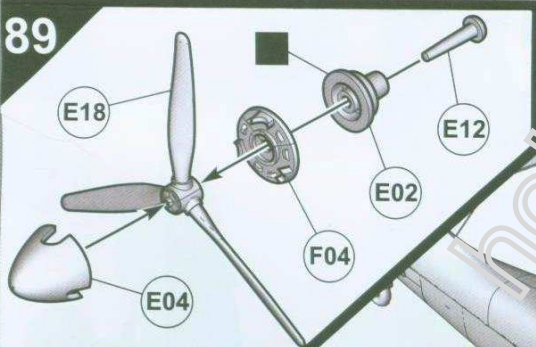
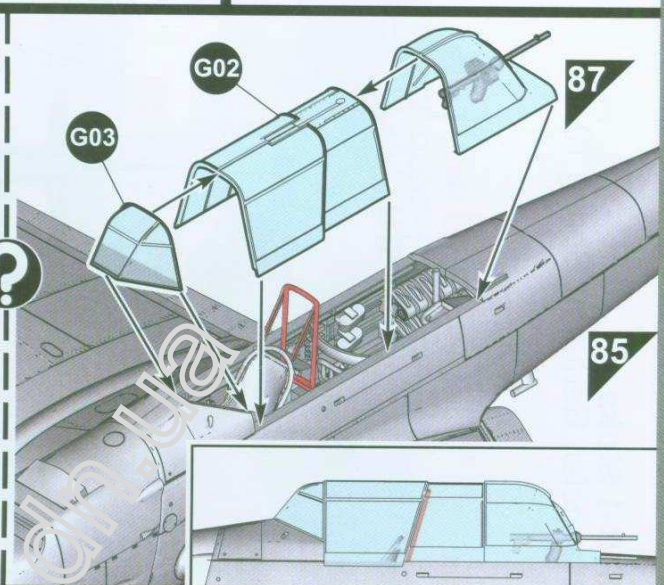
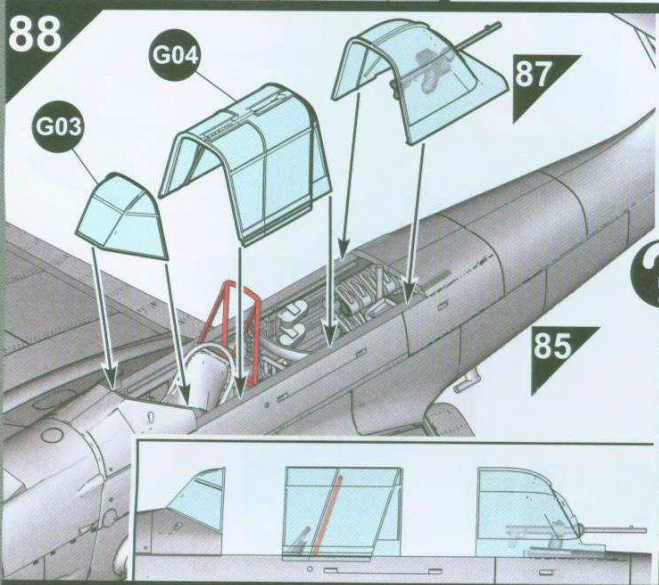
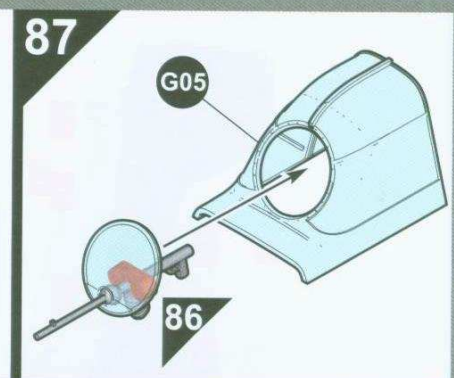
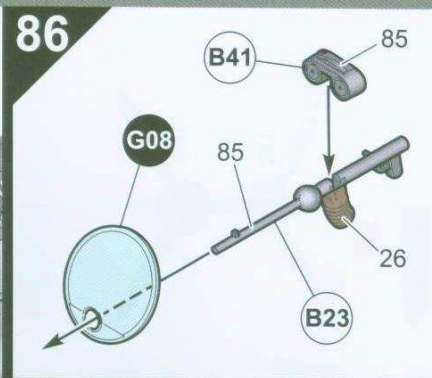
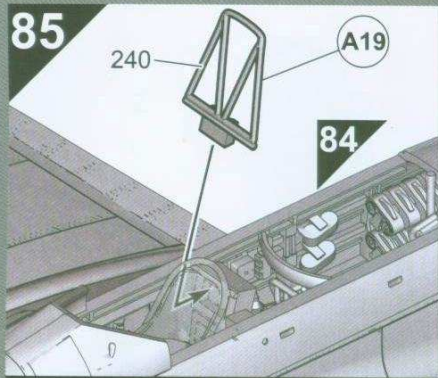

**A** Junkers Ju 87B-1 Stuka  
 II./Sturzkampfgeschwader 2, Bonn-Hangelar, Germany, Spring 1940.

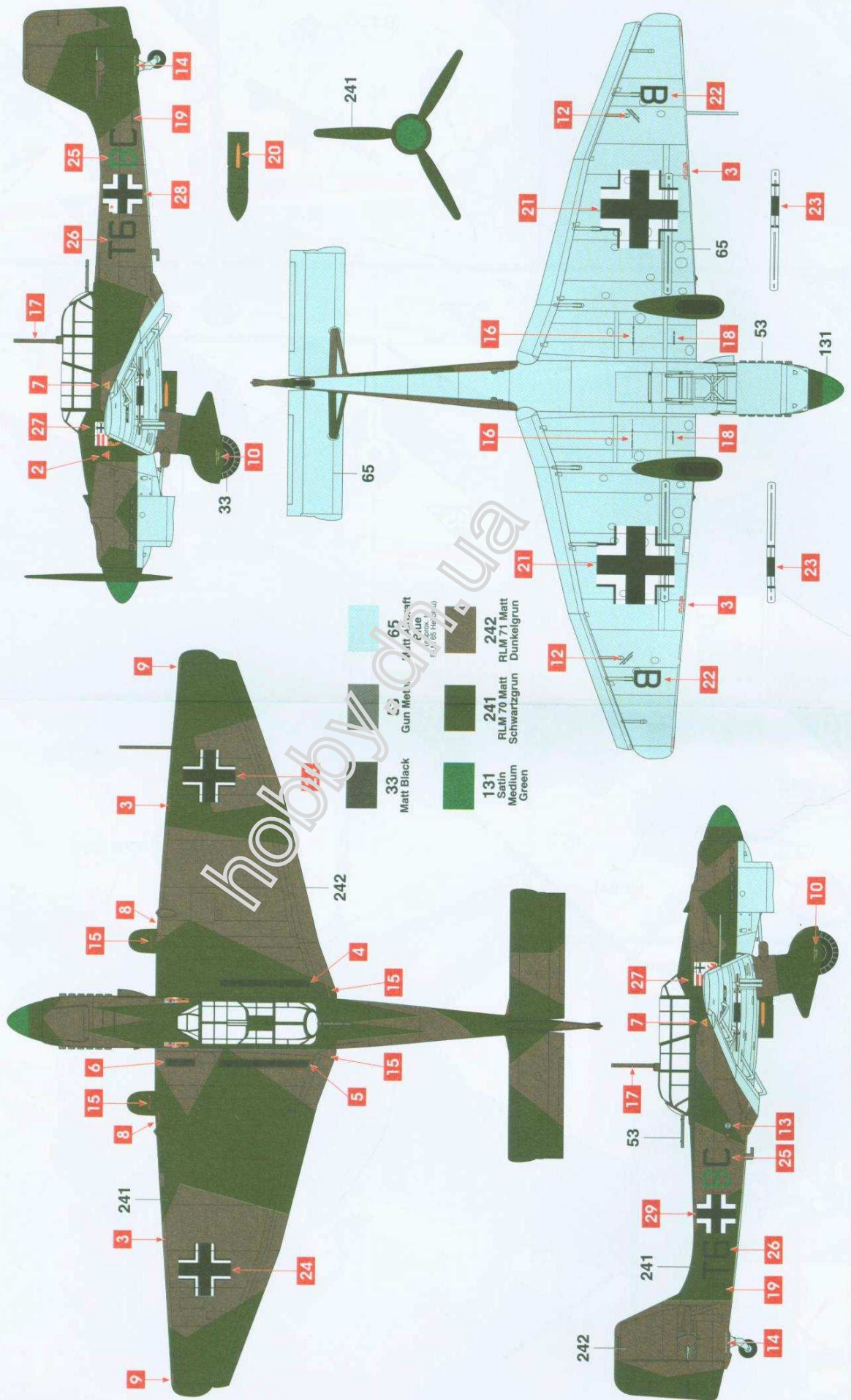

**B** Junkers Ju 87B-1 Stuka  
 Kampfgruppe 88, Legion Condor, Spain, 1938.

