



1:72 Handley Page Victor B.Mk.2 (BS)

A12008 SCALE MODEL CONSTRUCTION KIT | Wingspan: 508mm Fuselage Length: 486mm | Two Decal Schemes Included

GB The Handley Page (HP) Victor was a jet-powered, strategic bomber which, alongside the other 'V' bombers, the Avro Vulcan and Vickers Valiant, formed an essential part of Britain's nuclear deterrent during the early part of the Cold War. The Victor was designed to carry out long-range, low-altitude attacks, but was later relegated to an aerial refuelling role when it was no longer deemed effective as a strategic bomber. Subject to the RAF's requirements for greater tactical manoeuvrability and a higher ceiling, the B.2 variant with much more powerful Rolls Royce Conway engines was developed in 1959. Thirty-four were produced in total, of which several were later converted for reconnaissance and aerial refuelling purposes. Two RAF squadrons formed on the B.2 after it entered service in 1962, but it was soon succeeded by the B.2R, a conversion which allowed 'Blue Steel' nuclear missiles to be carried in addition to free-fall nuclear payloads. Following the introduction of submarine-launched Polaris missiles in 1969, the Victor was gradually relieved of its role as a nuclear deterrent but it remained a valuable asset to the RAF as a tanker up to its retirement in 1993.

FR Le Handley Page (HP) Victor était un bombardier à réaction stratégique. Avec l'Avro Vulcan et le Vickers Valiant, il faisait partie du trio des V-bombers qui constituaient un élément essentiel de la force de dissuasion nucléaire britannique pendant les premières années de la Guerre froide. Conçu pour effectuer des attaques à long rayon d'action et à haute altitude, le Victor fut converti plus tard en avion ravitailleur car il ne pouvait plus atteindre les performances souhaitées d'un bombardier stratégique. Pour satisfaire aux besoins de la RAF en matière de manoeuvrabilité tactique accrue et d'un plafond plus élevé, la variante B.2 propulsée par les plus puissants réacteurs Rolls Royce Conway fut développée en 1959. Trente-quatre exemplaires furent fabriqués en total dont plusieurs furent ensuite utilisés pour le ravitaillement aérien ainsi que pour la reconnaissance. Après être entré en service au sein de deux escadrons de la RAF en 1962, le B.2 fut bientôt suivi par le B.2R, une conversion qui permettait l'emport des missiles nucléaires 'Blue Steel' en plus des charges utiles nucléaires à chute libre. Après l'introduction en 1969 des missiles

DE Die Handley Page (HP) Victor war ein strategischer Bomber mit Strahltrieb und, neben den anderen „V“-Bombern (Avro Vulcan und Vickers Valiant), zu Beginn des Kalten Krieges ein unverzichtbarer Bestandteil der nuklearen Abschreckung Großbritanniens. Die Victor war für Distanzangriffe im Tiefflug ausgelegt; einige Zeit später wurde sie jedoch nicht mehr als wirksamer strategischer Bomber angesehen und daher zu einem Luftbetankungsflugzeug umfunktioniert. Dem Bedarf der RAF an besserer taktischer Manövrierfähigkeit und einer größeren Höhe entsprechend wurde 1959 die B.2-Variante mit wesentlich leistungsfähigeren Rolls-Royce Conway-Triebwerken entwickelt. Insgesamt 34 Stück wurden produziert, von denen später mehrere für Aufklärungs- und Luftbetankungszwecke umgebaut wurden. Zwei B.2-Geschwader der RAF entstanden nach der Inbetriebstellung im Jahre 1962; dem folgte jedoch bald die B.2R, ein Umbau, der neben frei fallenden Nuklearladungen das Mitführen von „Blue Steel“-Nuklearraketen ermöglichte. Nach Einführung der U-Boot-gestützten Polaris-Raketen (1969) wurde die Victor peu à peu nicht mehr als nukleares Abschreckungsmittel eingesetzt, blieb aber bis zu ihrer Außerdienststellung

ES El Handley Page (HP) Victor fue un bombardero estratégico de propulsión a chorro, junto con los otros bombarderos "V" (Avro Vulcan y Vickers Valiant), constituyeron un elemento esencial de la fuerza de disuasión nuclear británica en los primeros años de la Guerra Fría. El Victor fue diseñado para llevar a cabo ataques a poca distancia y desde baja altitud, pero quedaría relegado a tareas de repostaje aéreo al dejar de considerarse eficaz como bombardero estratégico. En 1959 se desarrolló la variante B.2, con sujeción a los requisitos de la RAF de mayor maniobrabilidad táctica y a un techo más elevado, así como con motores Rolls Royce Conway de potencia muy superior. En total se produjeron treinta y cuatro aparatos, varios de los cuales serían reconvertidos para tareas de reconocimiento y repostaje aéreo. Tras su entrada en servicio en 1962, se formaron dos escuadrones de la RAF sobre el B.2, que pronto sería reemplazado por el B.2R, una variante que permitía transportar misiles nucleares "Blue Steel" además de tres cargas nucleares de caída libre. Con la introducción de los misiles Polaris lanzados desde submarinos en 1969, el Victor fue apartado gradualmente de su papel de disuasión nuclear, pero siguió utilizándose como

SE Handley Page (HP) Victor var ett jetdrivet strategiskt bombplan som tillsammans med de andra "V"-bombplanen Vulcan och Vickers Valiant utgjorde en väsentlig del av Storbritanniens kärnvapenvärskräkning under det kalla krigets tidiga skede. Victor var utformat för attacker på låg höjd och med lång räckvidd, men relegerades senare till flygtankningsuppdrag när det inte längre ansågs vara effektivt som strategiskt bombplan. I takt med RAF:s förändrade krav på bättre taktisk manöverbarhet och utökad maxflyghöjd utvecklade man 1959 varianten B.2 som hade mycket mer kraftfulla Rolls Royce Conway-motorer. 34 plan tillverkades, av vilka ett antal sedermera konverterades till spanings- och tankningsplan. Två RAF-skvadroner bildades runt B.2 efter att det sattes i tjänst 1962, men planet ersattes snart av B.2R, en vidareutveckling som möjliggjorde bestyckning med "Blue Steel"-kärnvapenrobotar tillsammans med nukleära fällbomber. Efter introduktionen av ubåtsavfyrate Polaris-robotar 1969 förlorade Victor gradvis sin roll som kärnvapenvärskräkning, men fortsatte att utgöra ett värdefullt inslag som tankflyg

Specification
Maximum Speed: 645 mph (1038km/h)
Range: 4,600 miles (7,400 km) with maximum fuel
Wingspan: 120 ft 0 in (37.00m)
Length: 114 ft 11.0 in (34.78 m)
Armament: Up to 35 x 1000 lb (450 kg) bombs or 1x blue steel nuclear missile

Polaris lancés par sous-marin, le Victor cessa progressivement de jouer son rôle de dissuasion nucléaire mais il resta un atout précieux de la RAF en tant que citerne volante jusqu'à sa retraite en 1993.

Spécification:
Vitesse maximale: 1038 km/h
Autonomie: 7.400 km avec carburant maximum
Envergure: 37,00 m
Longueur: 34,78 m
Armement: Jusqu'à 35 bombes de 450 kg ou un missile nucléaire Blue Steel

im Jahre 1962 ein für die RAF wertvolles Betankungsflugzeug.

Spesifikation:
Maximal hastighet: 1038 km/h
Räckvidd: 7400 km med full tank
Spännvidd: 37,00 m
Längd: 34,78 m
Bestyckning: Upp till 35 st. 450 kg bomber eller 1 Blue Steel-kärnvapenrobot

Airfix would like to thank: Dennis Robinson, John Adams, Arthur Bentley, Andre Tempest, Ian Finch and all at Yorkshire Air Museum (www.YorkshireAirMuseum.org)

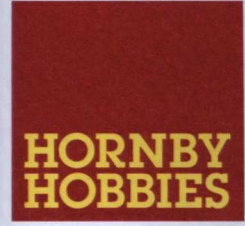

FOR BEST RESULTS:
Surfaces to be painted should be clean — before parts are removed from the sprue, wash in warm, soapy water, rinse and dry thoroughly. Stir paints thoroughly before use.

PLEASE NOTE:
Some parts in the kit may not be required to build the model specified.

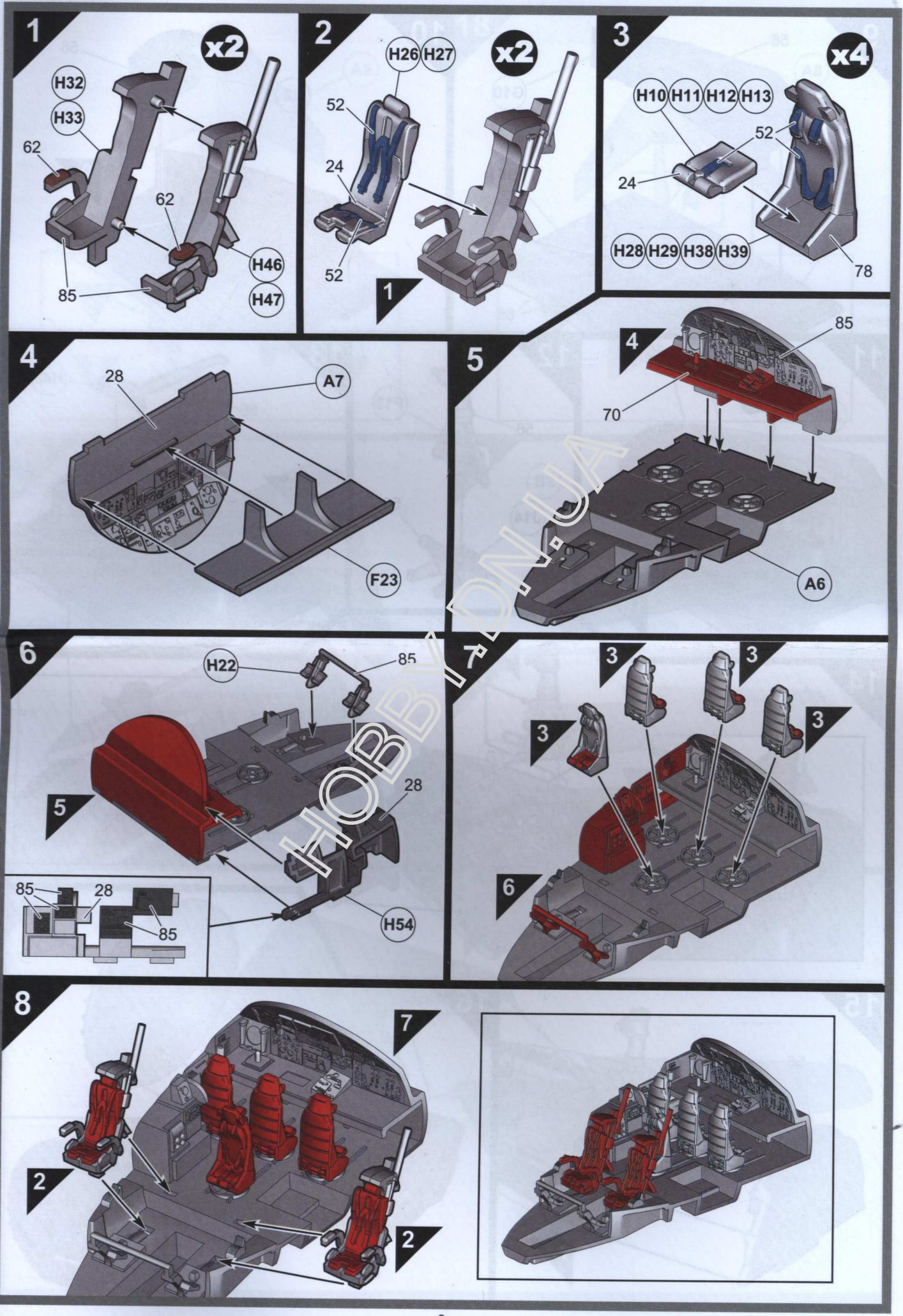

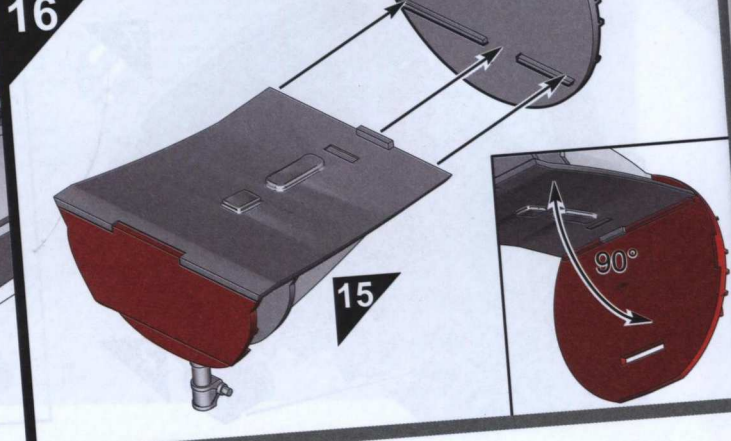
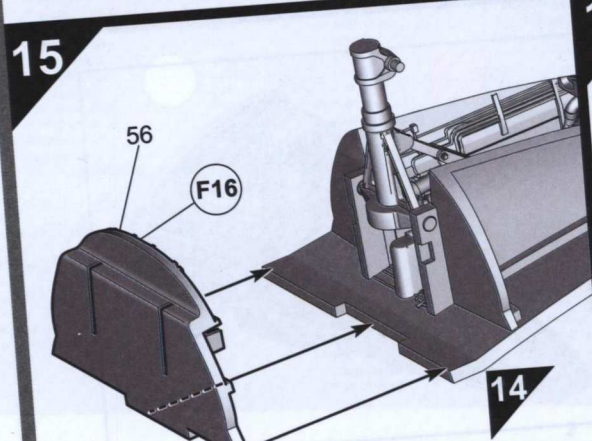
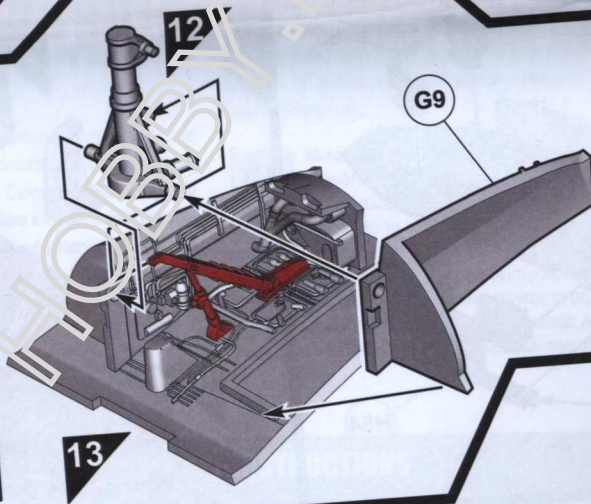
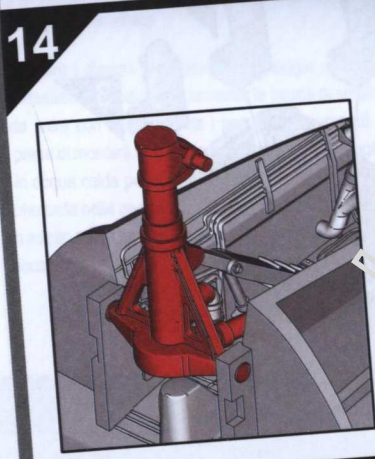
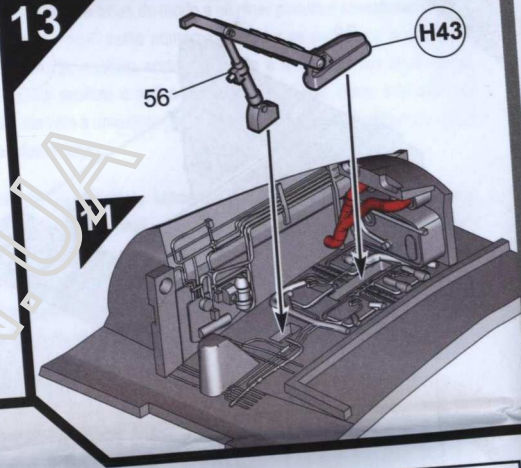
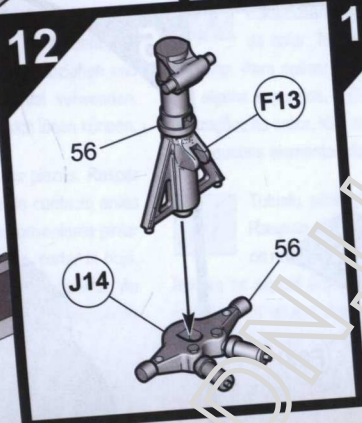
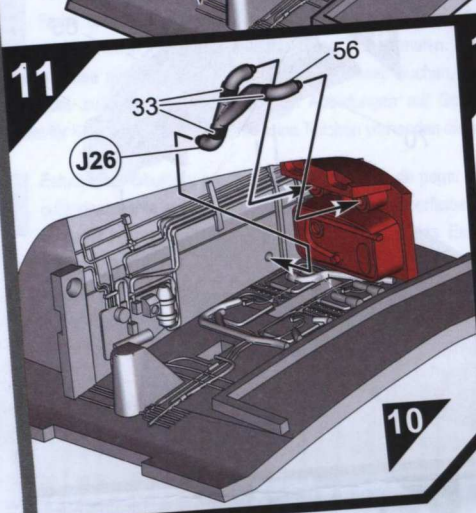
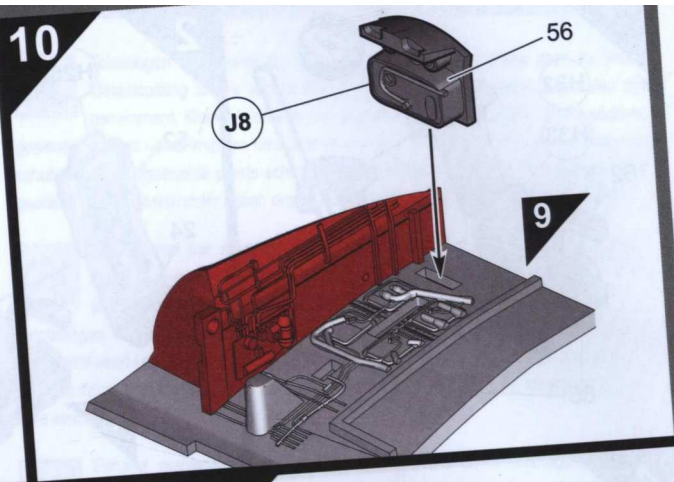
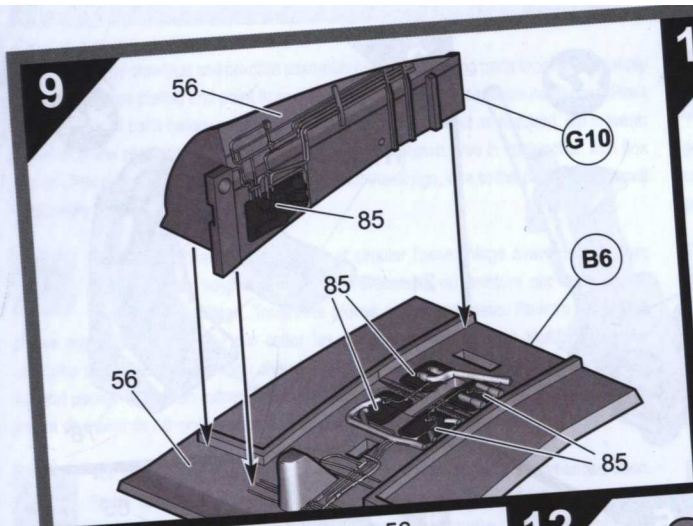

17

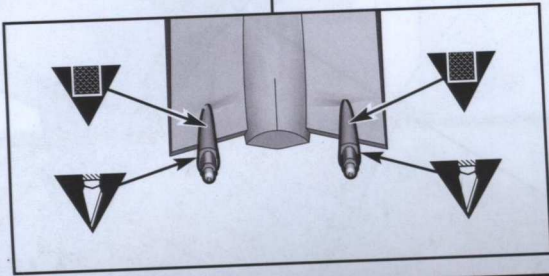
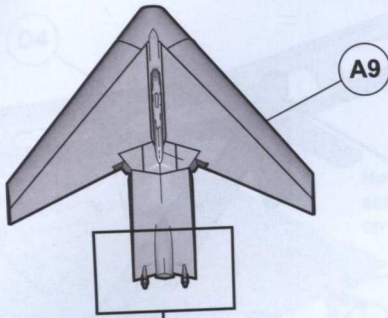

18

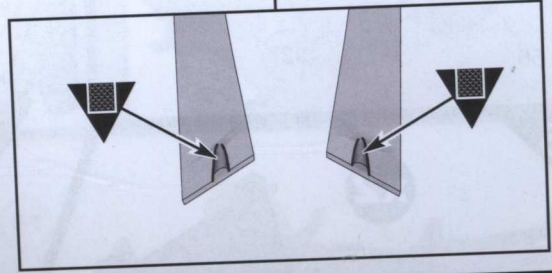
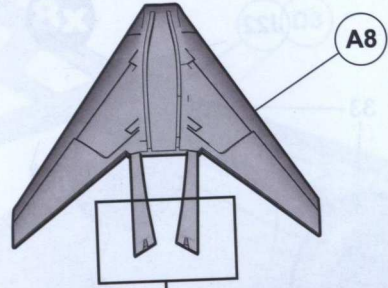

19

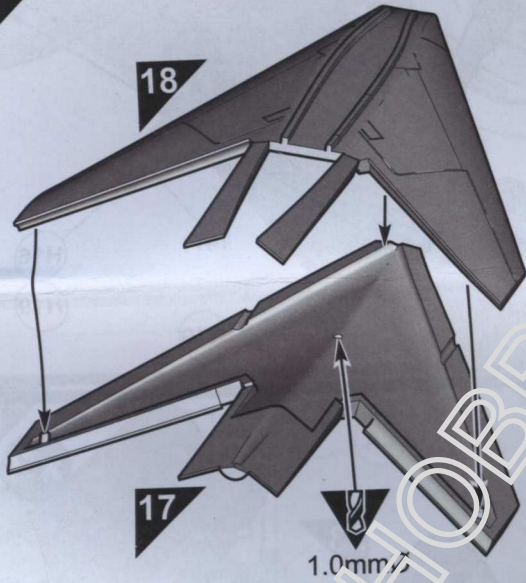

20

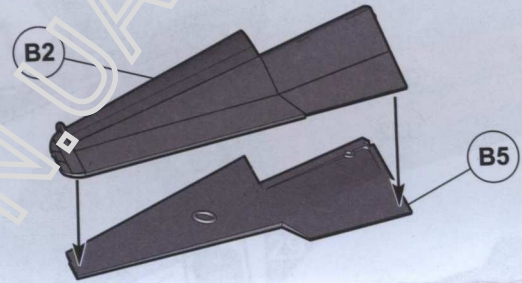

21

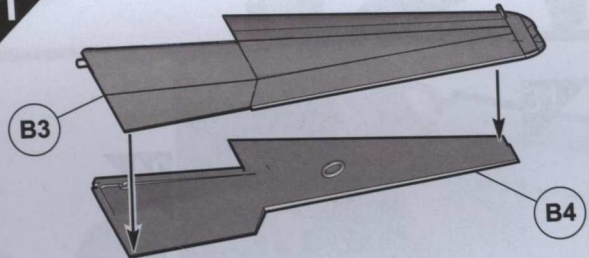

22

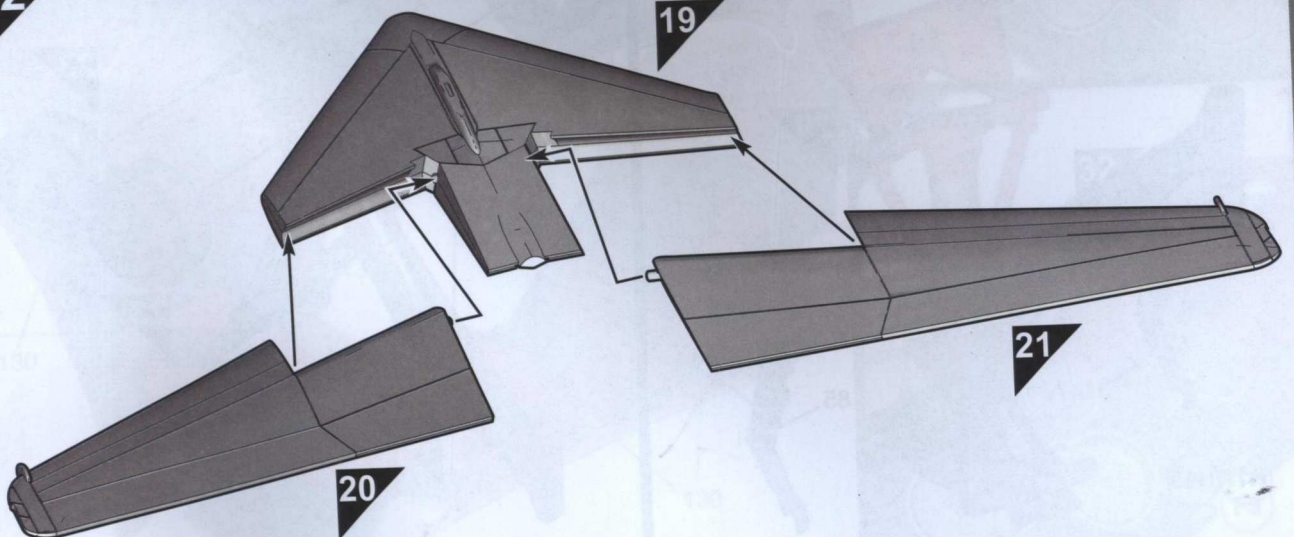

23

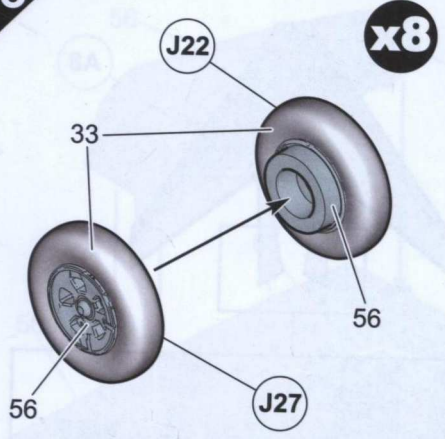

24

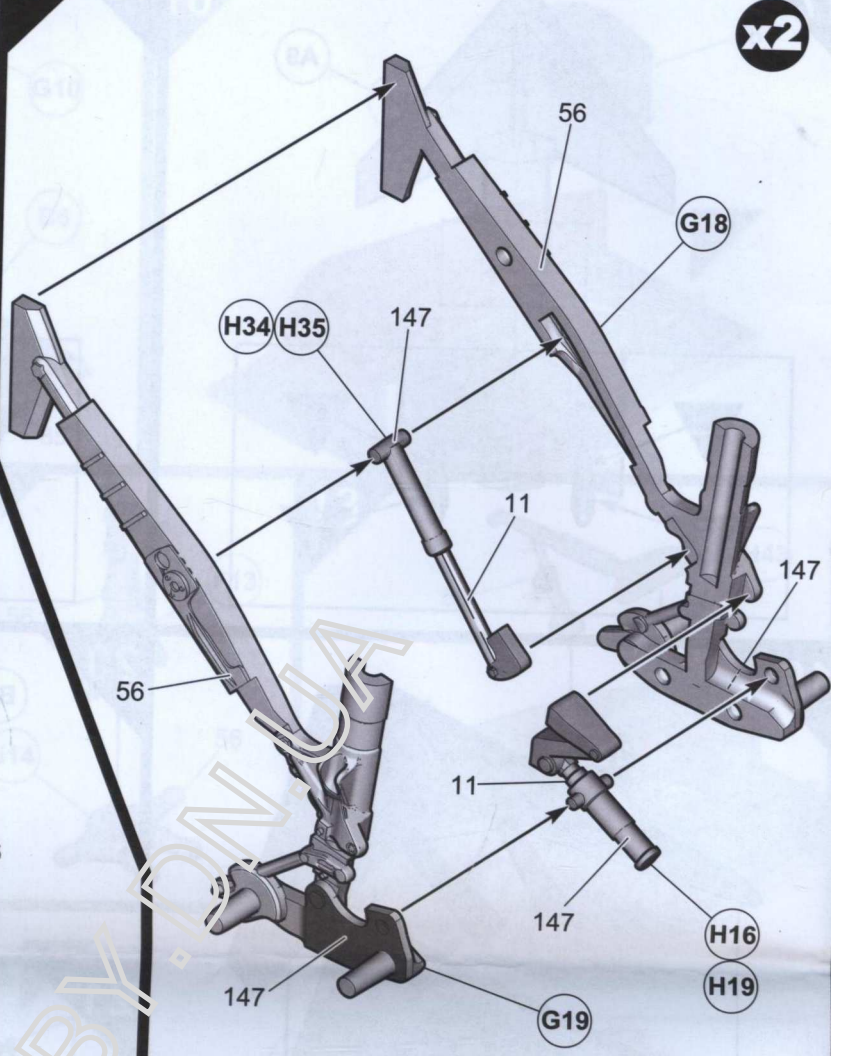

25

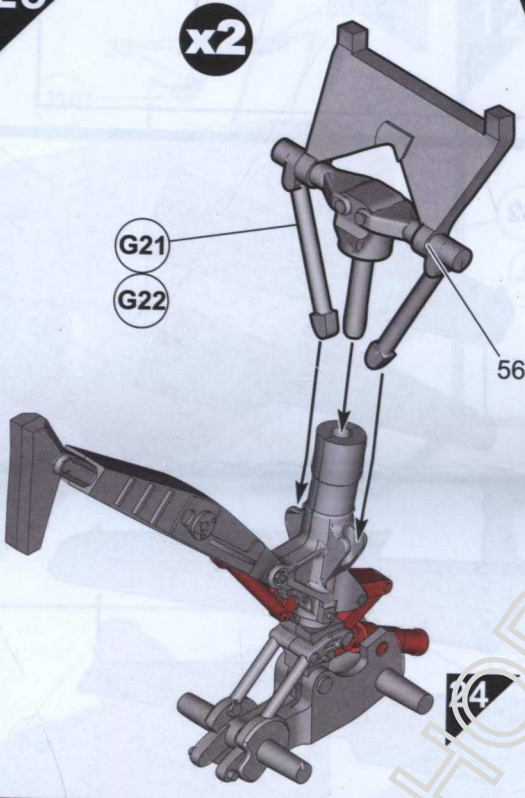

27

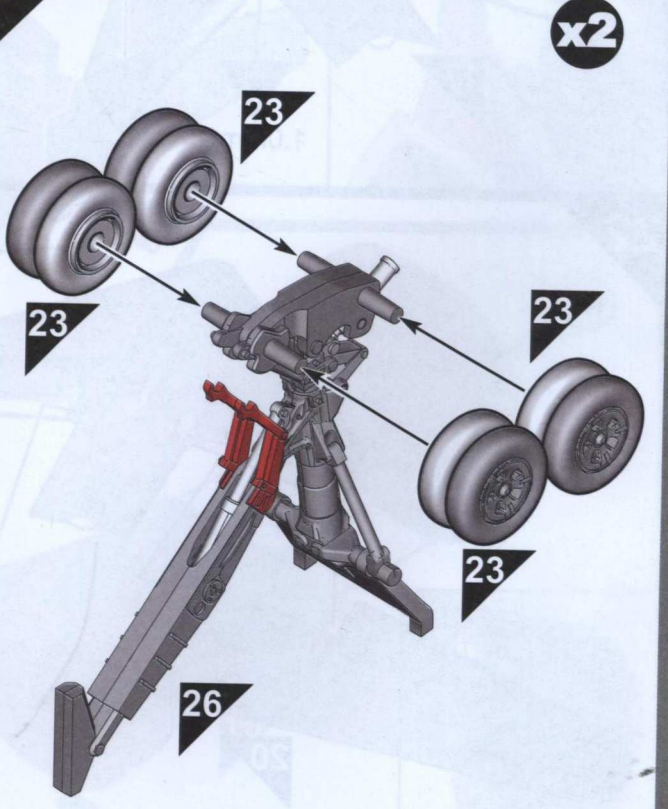

26

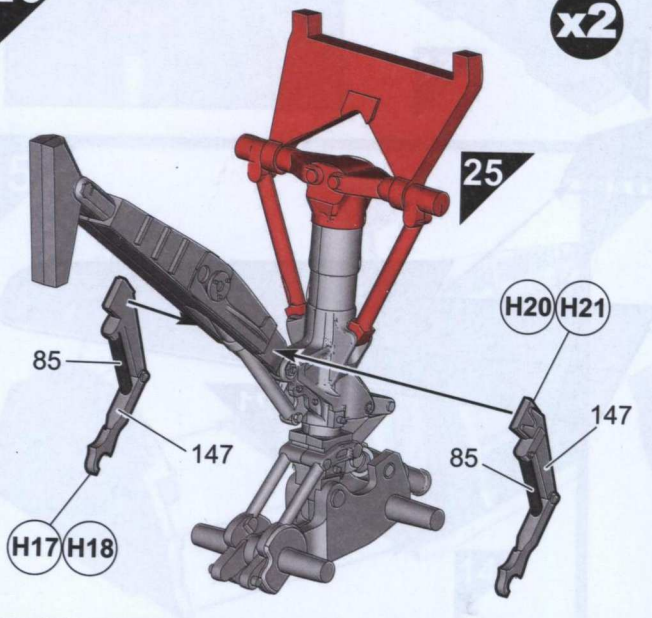

28

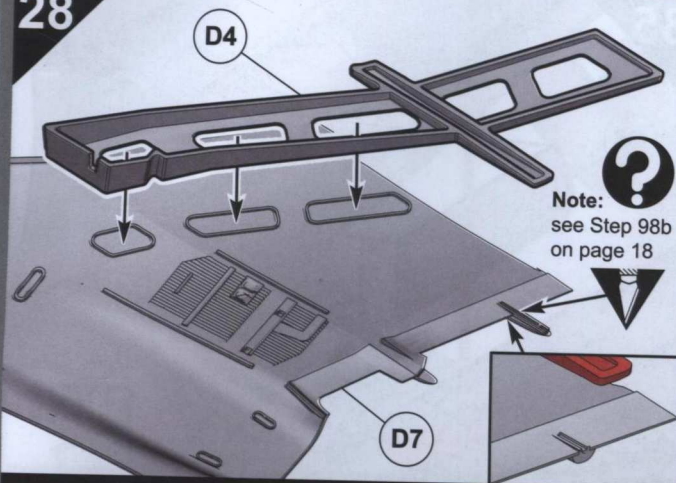

29

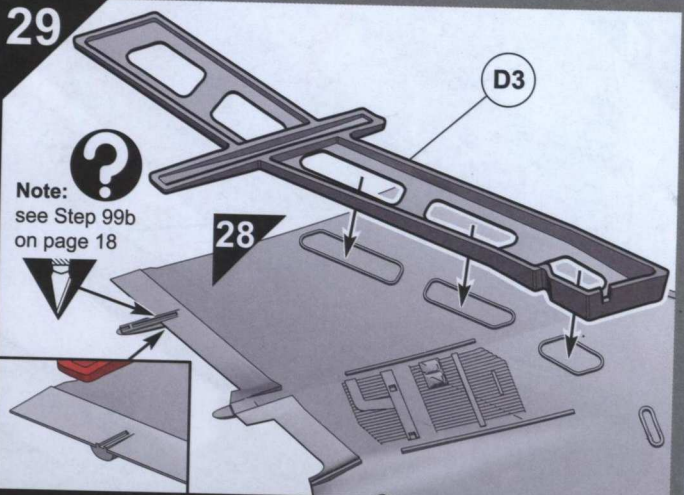

30

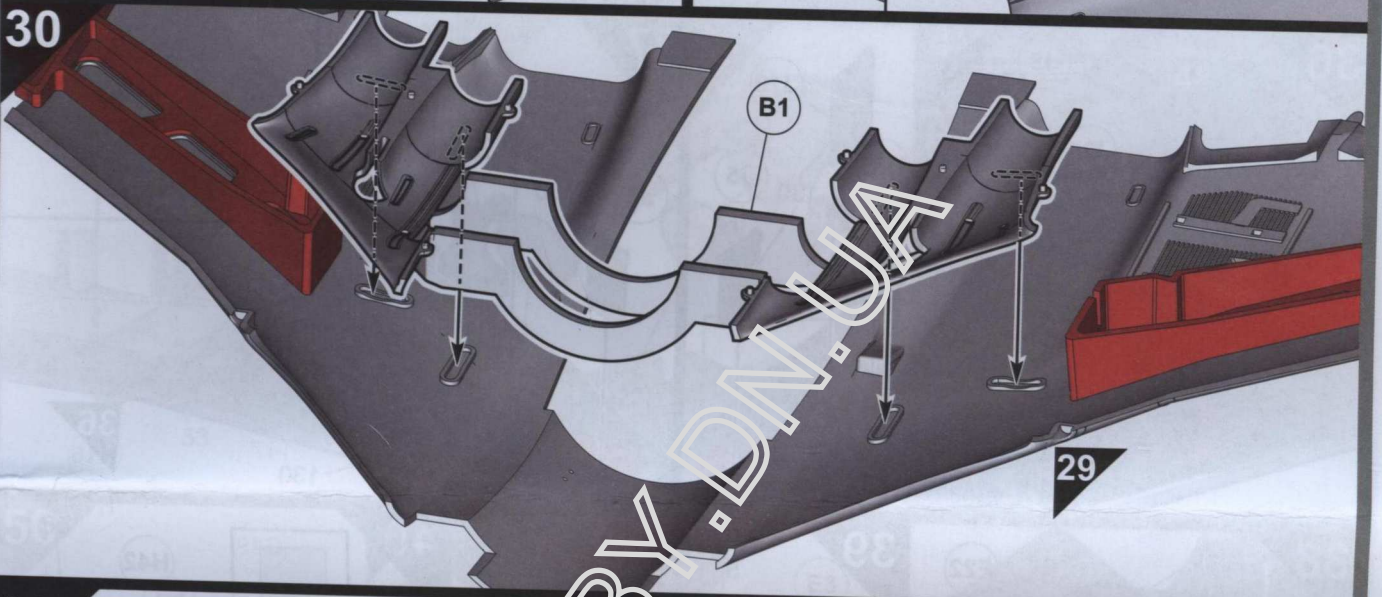

31

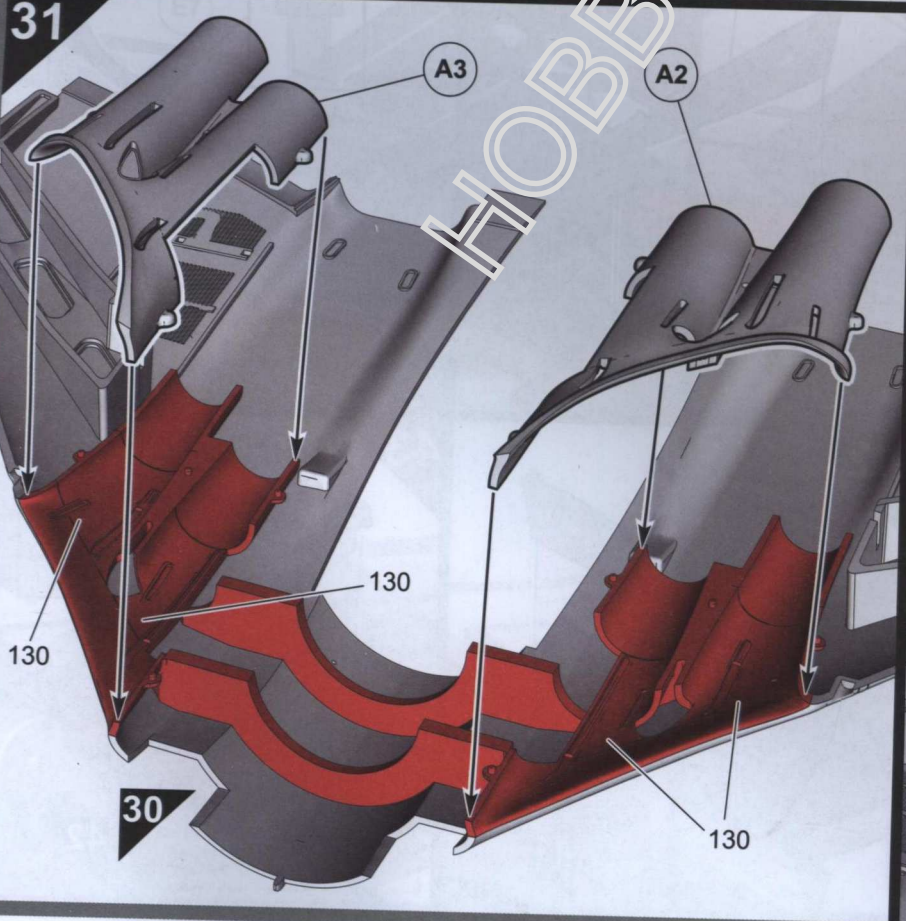

32

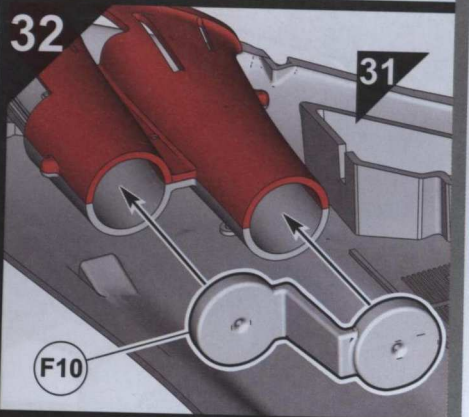

33

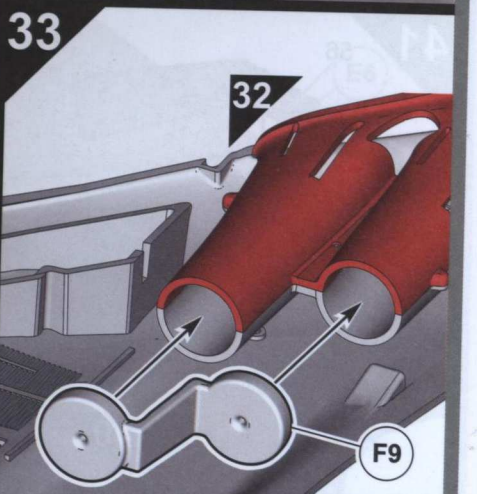

34

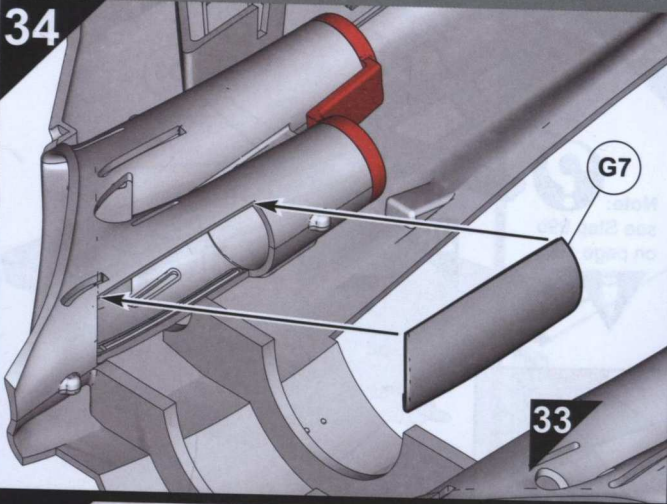

35

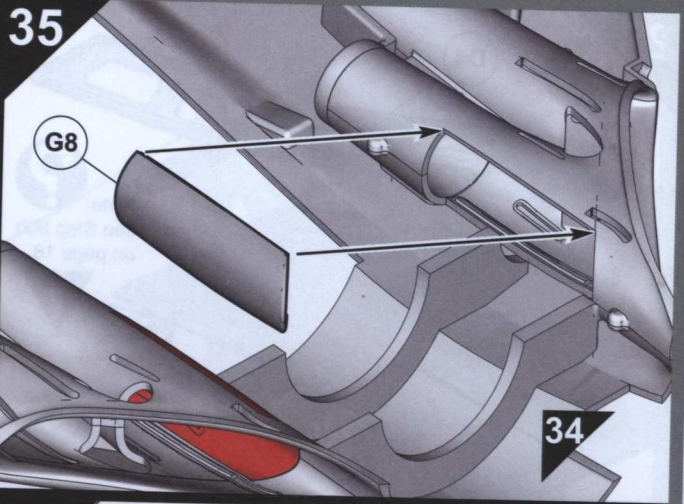

36

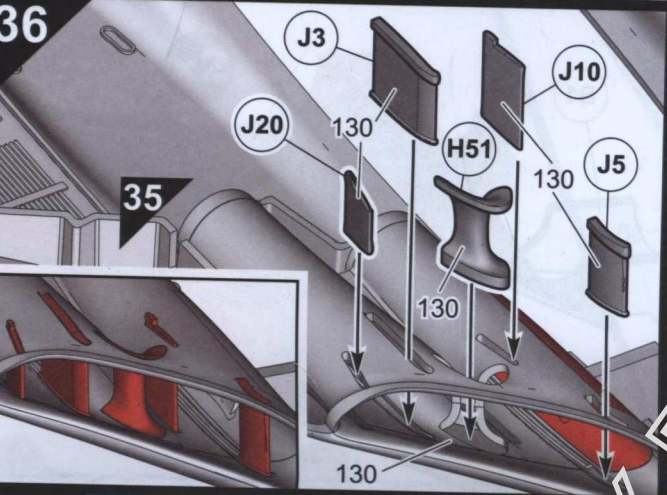

37

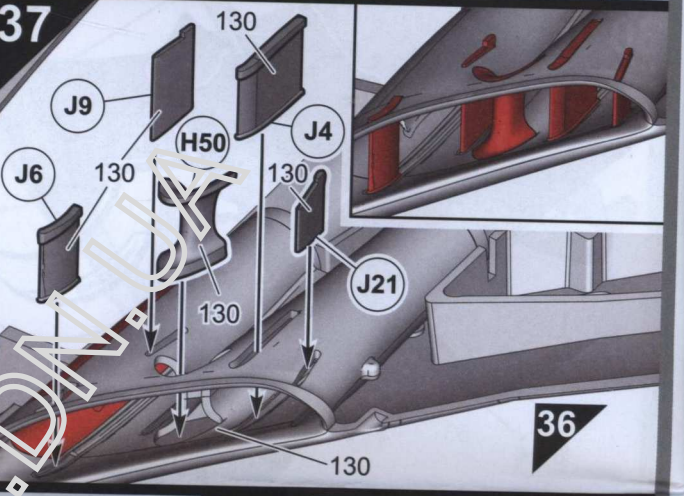

38

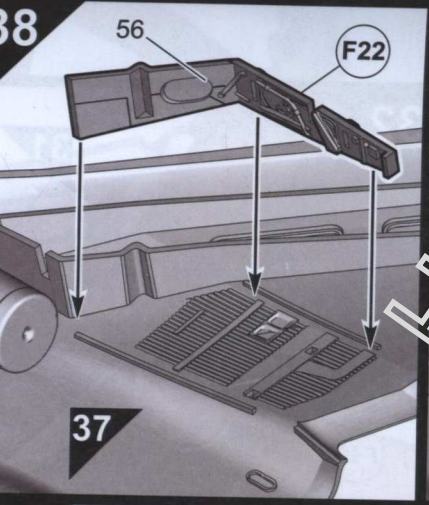

39

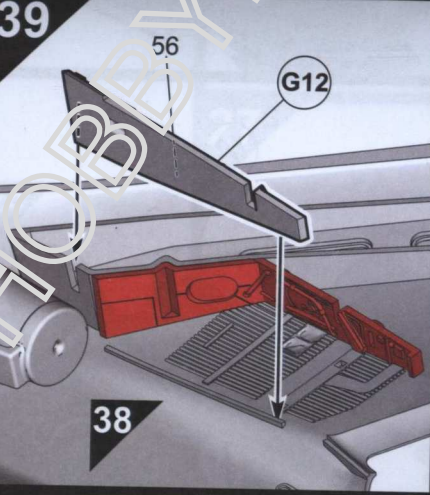

40

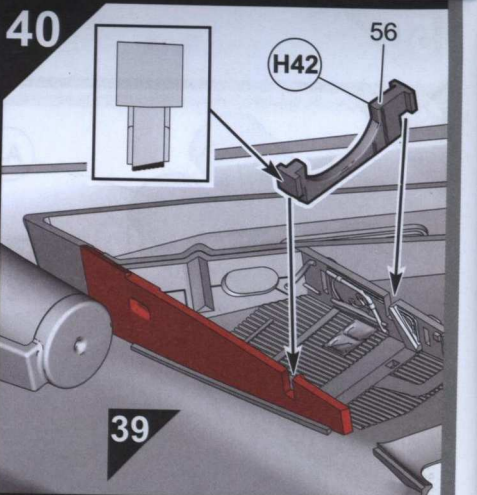

41

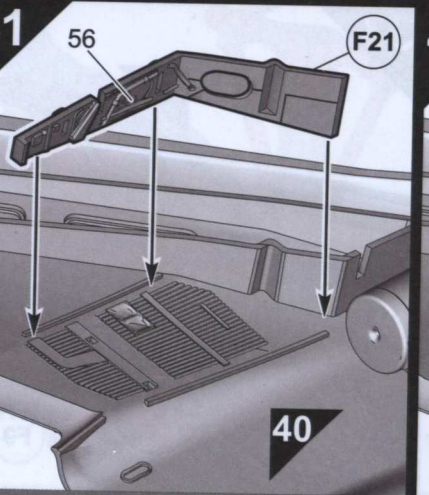

42

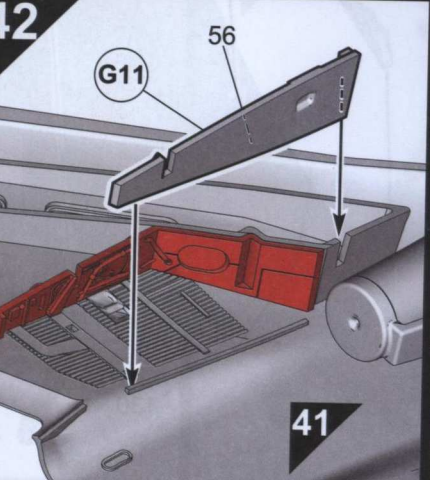

43

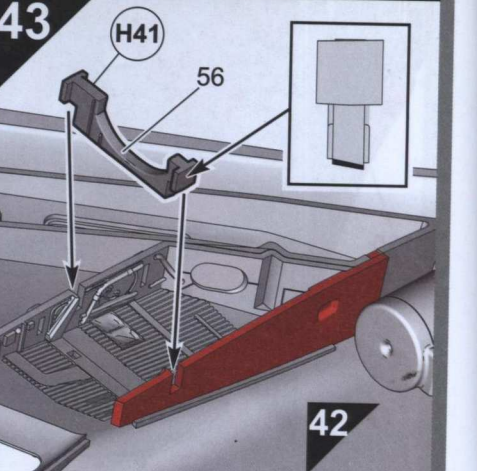

44

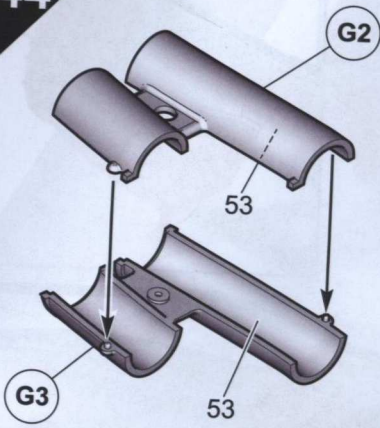

45

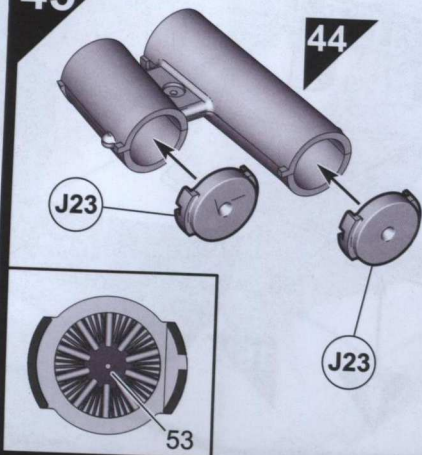

46

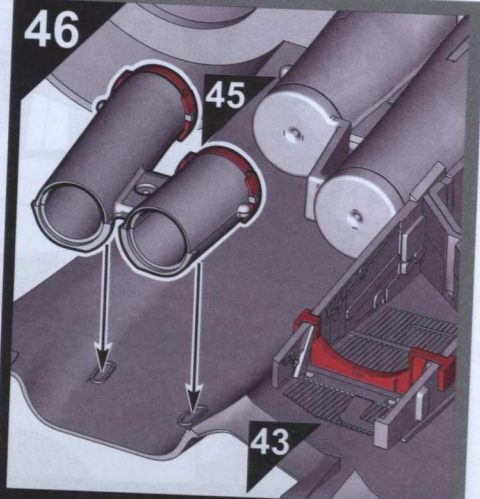

47

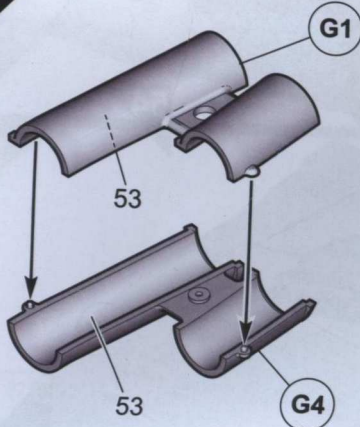

48

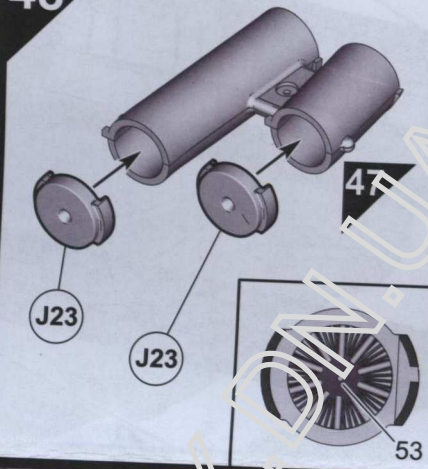

49

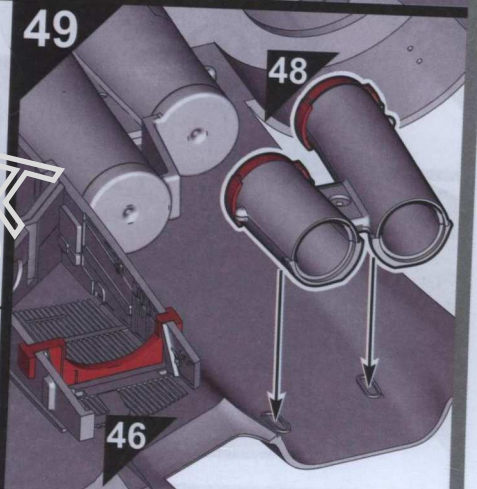

50

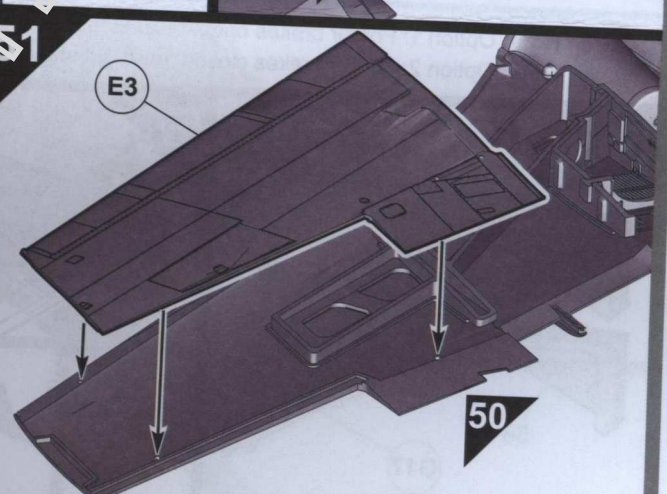
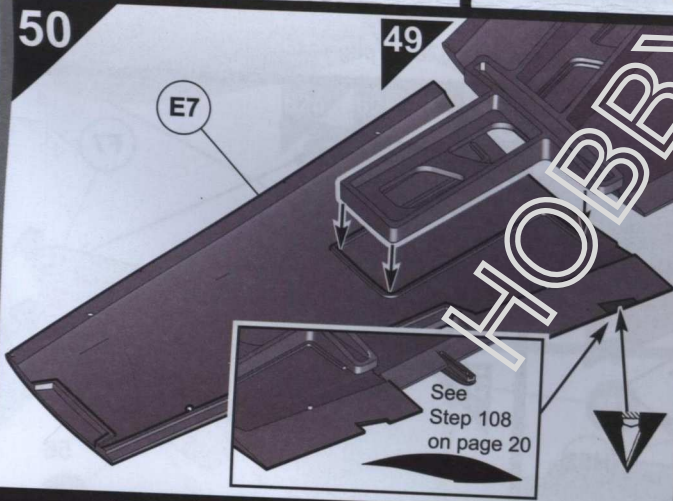

52

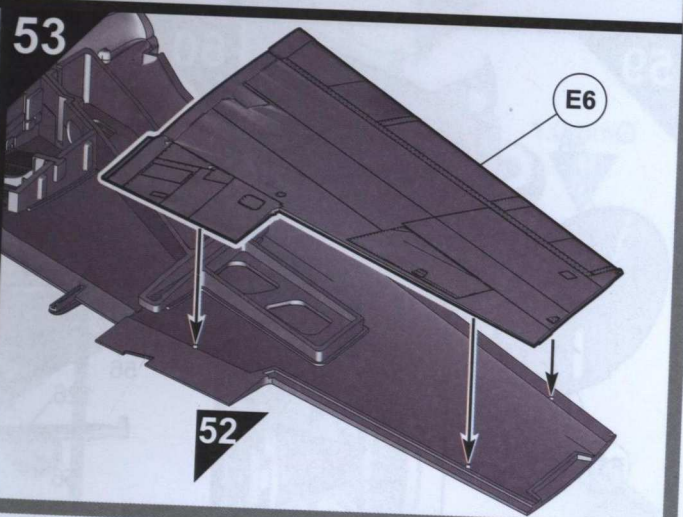
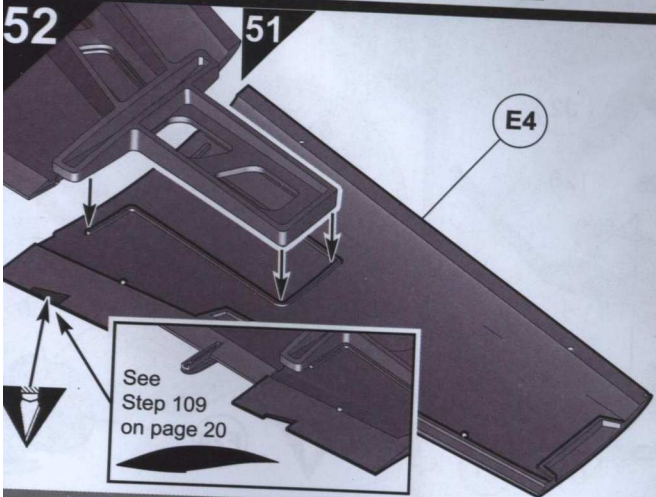

54

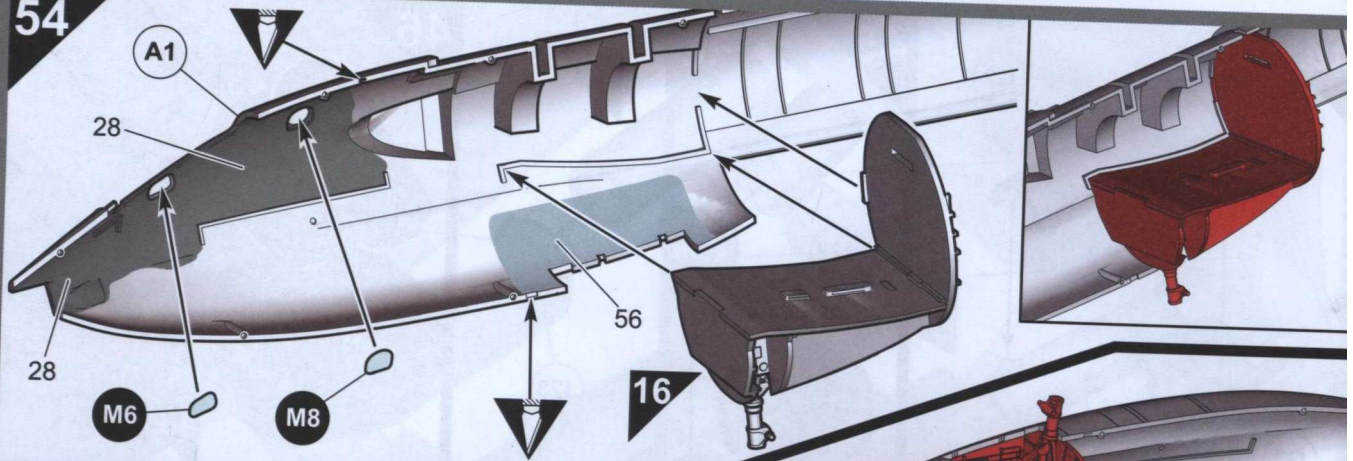

55

1.0mmØ



See Step 115 page 21

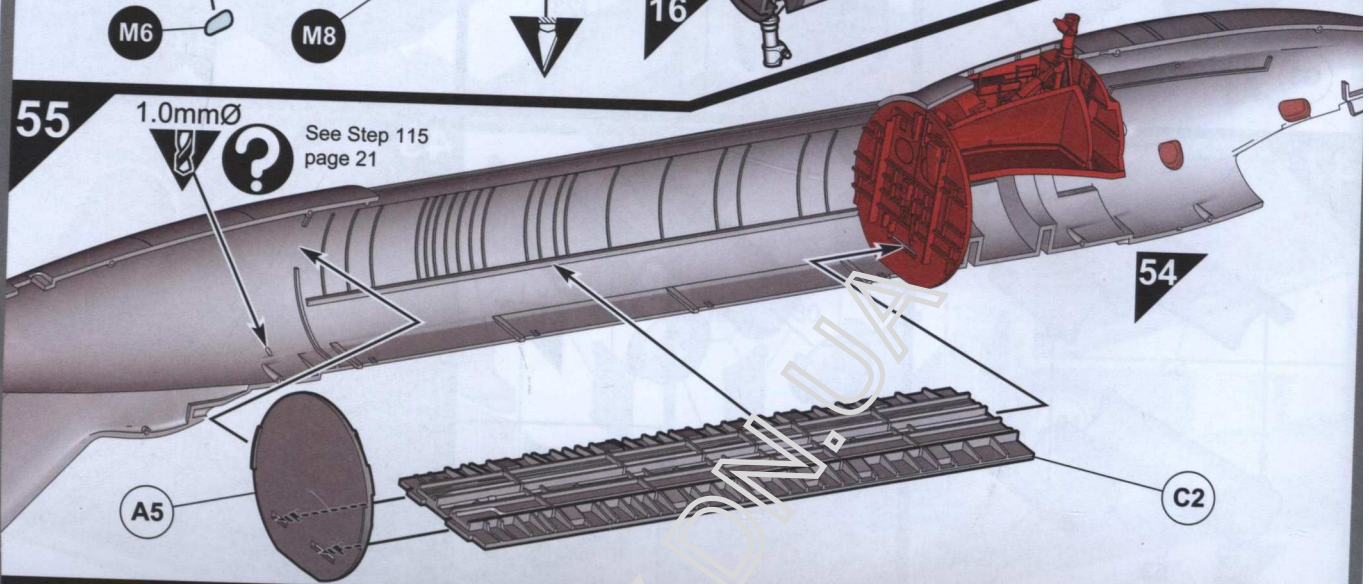

Note: Option 1: For air brakes open, build steps 56 to 62a.

Note: Option 2: For air brakes closed, miss out steps 56 to 62a and refer to step 62b on page 11.

56

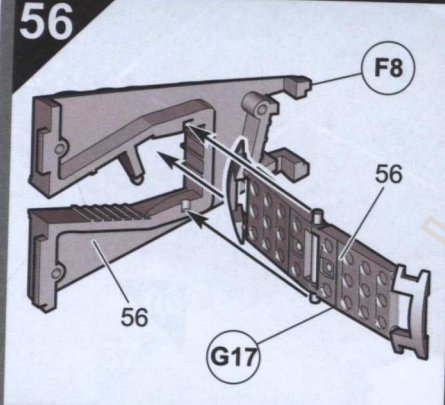

57

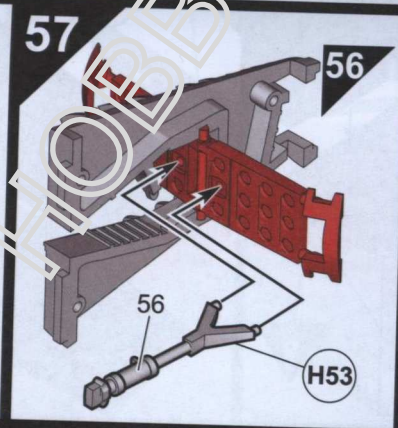

58

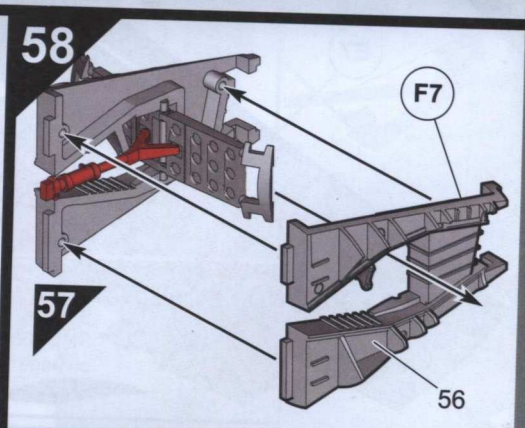

59

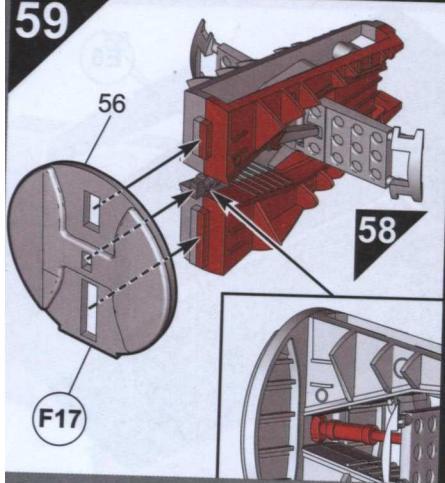

60

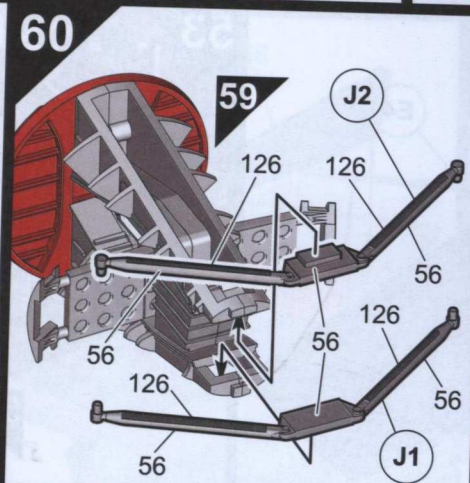

61

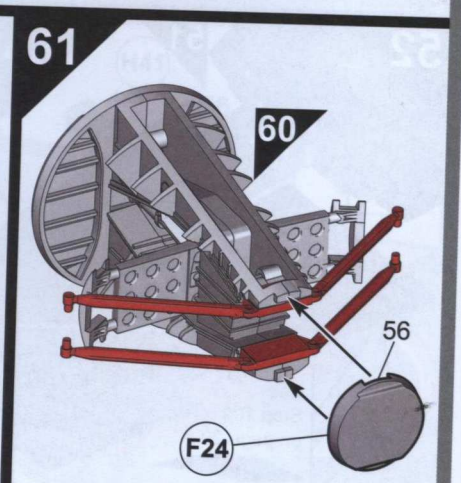

62a

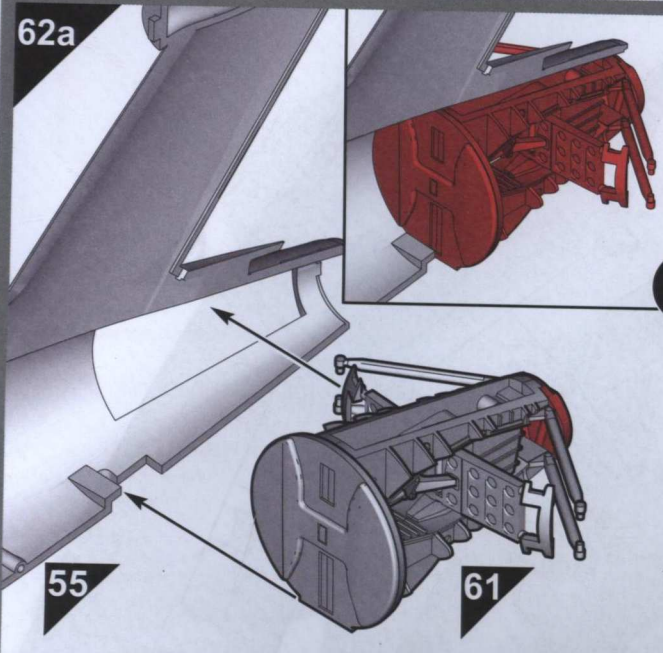

62b

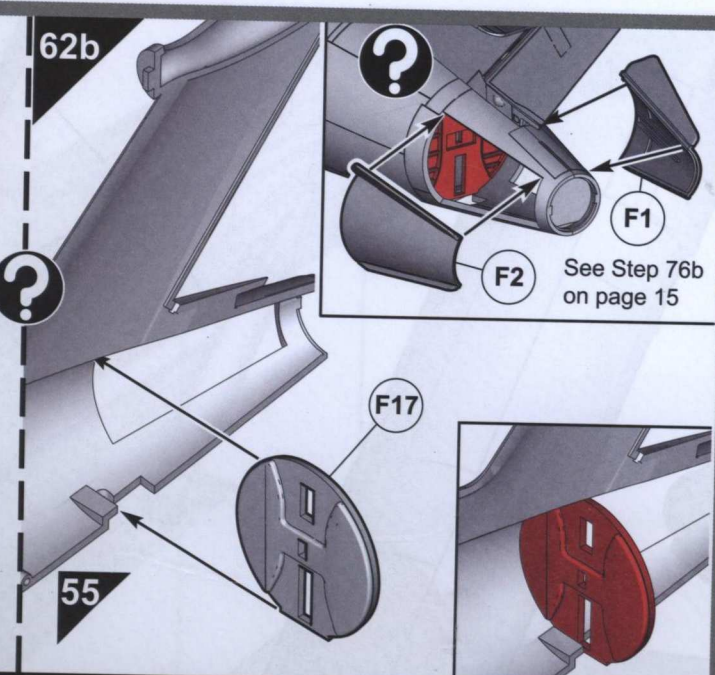

63

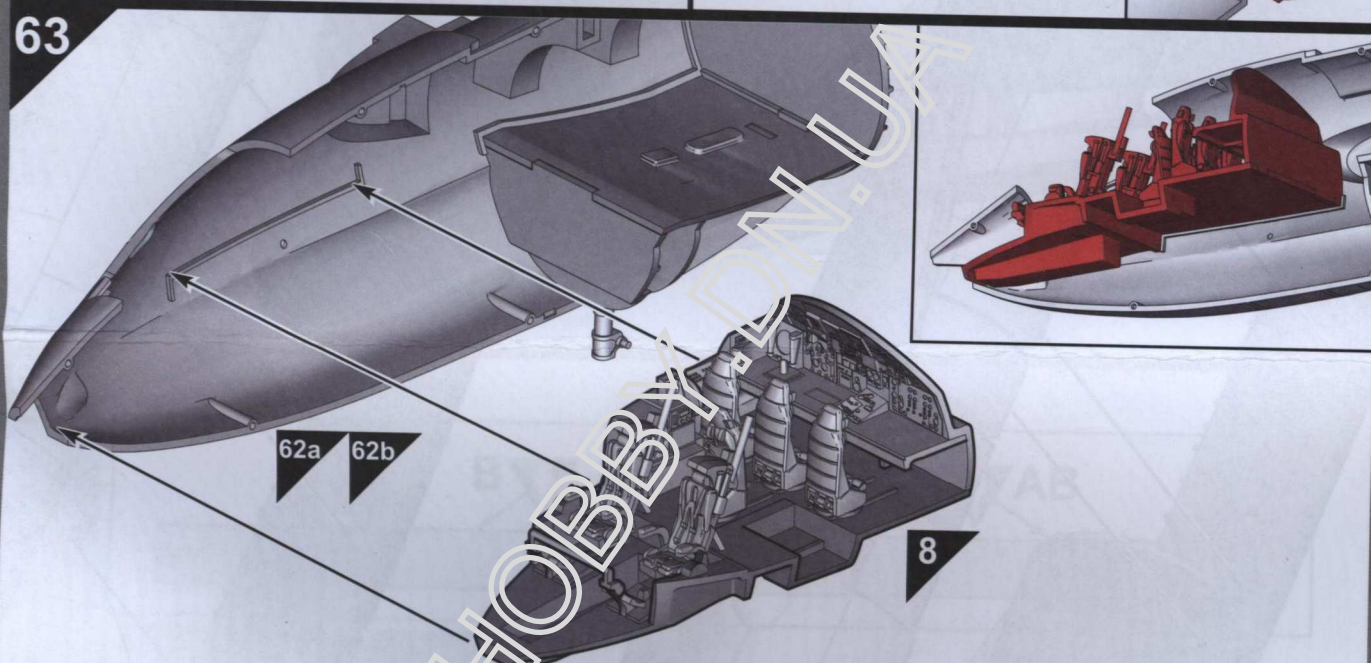

64

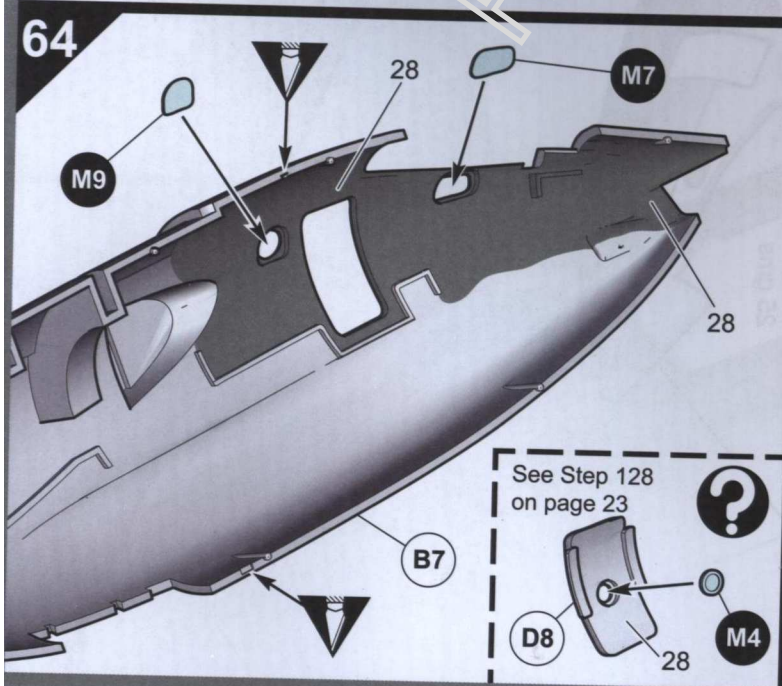

65

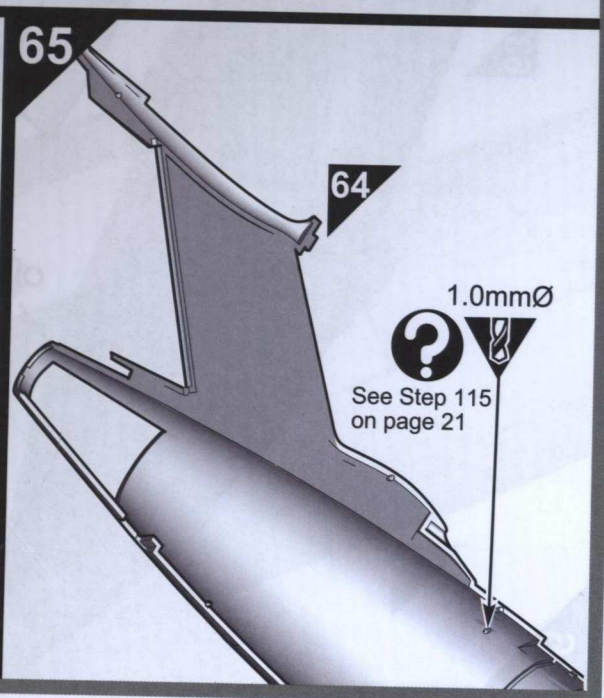

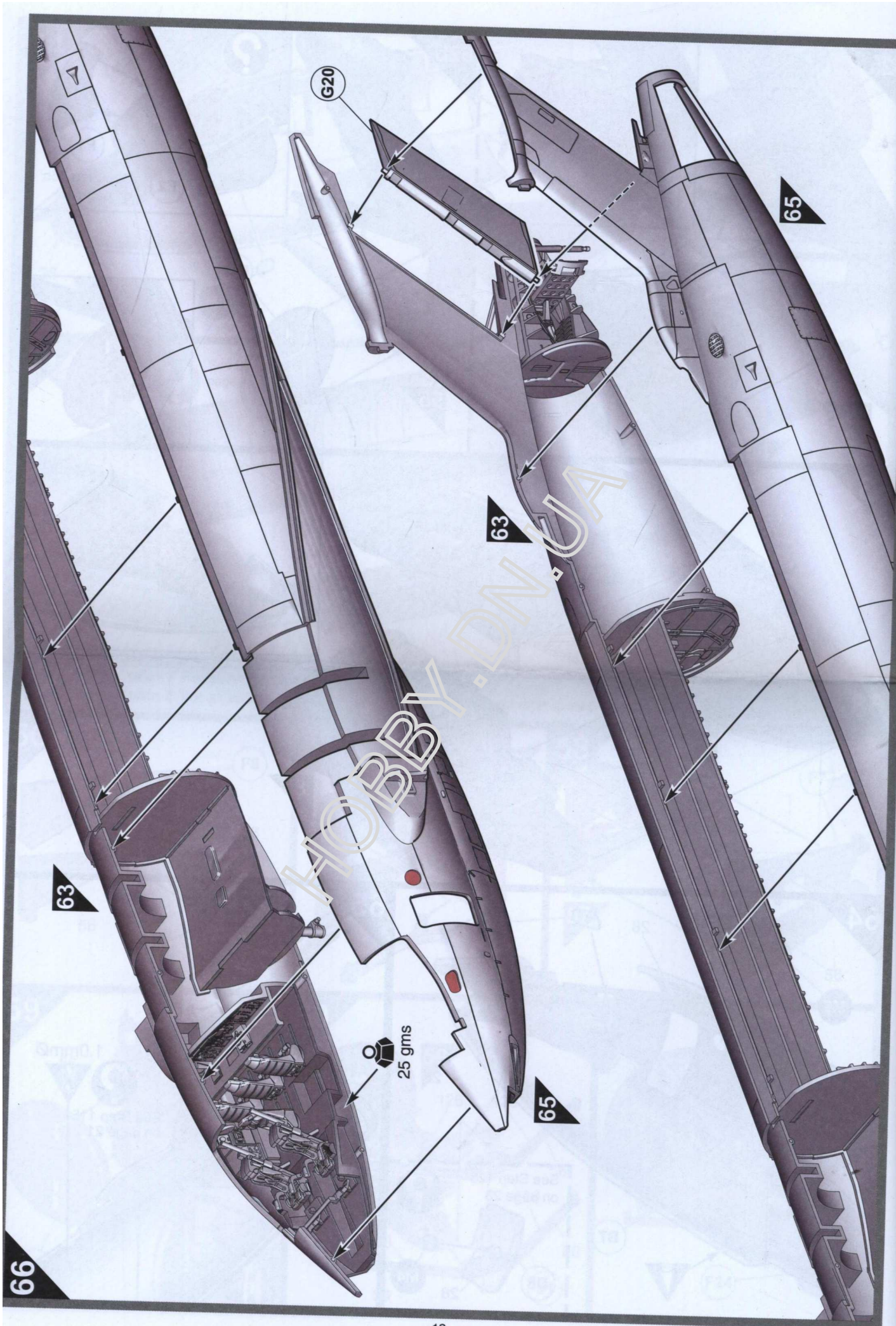

67

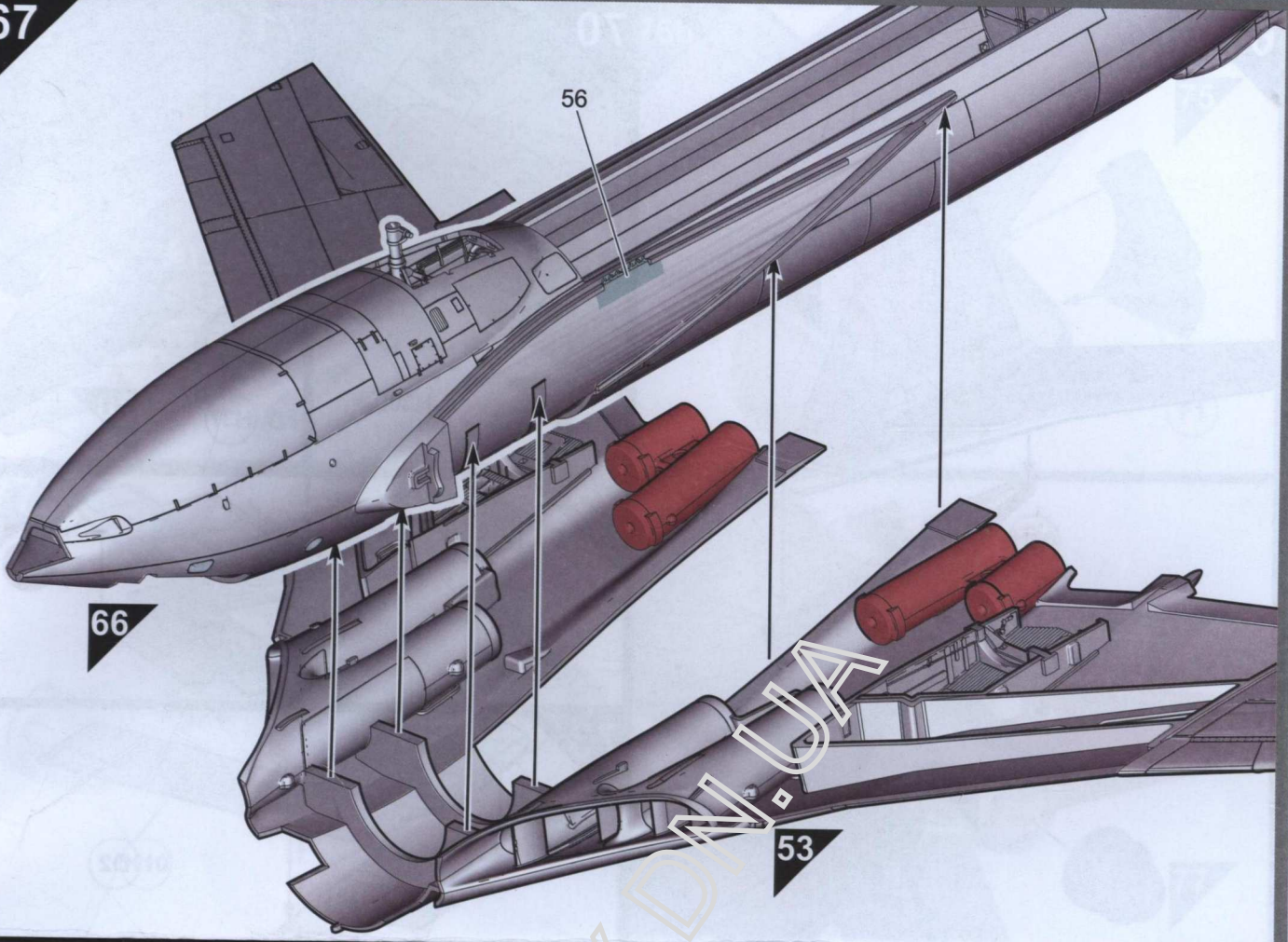

68

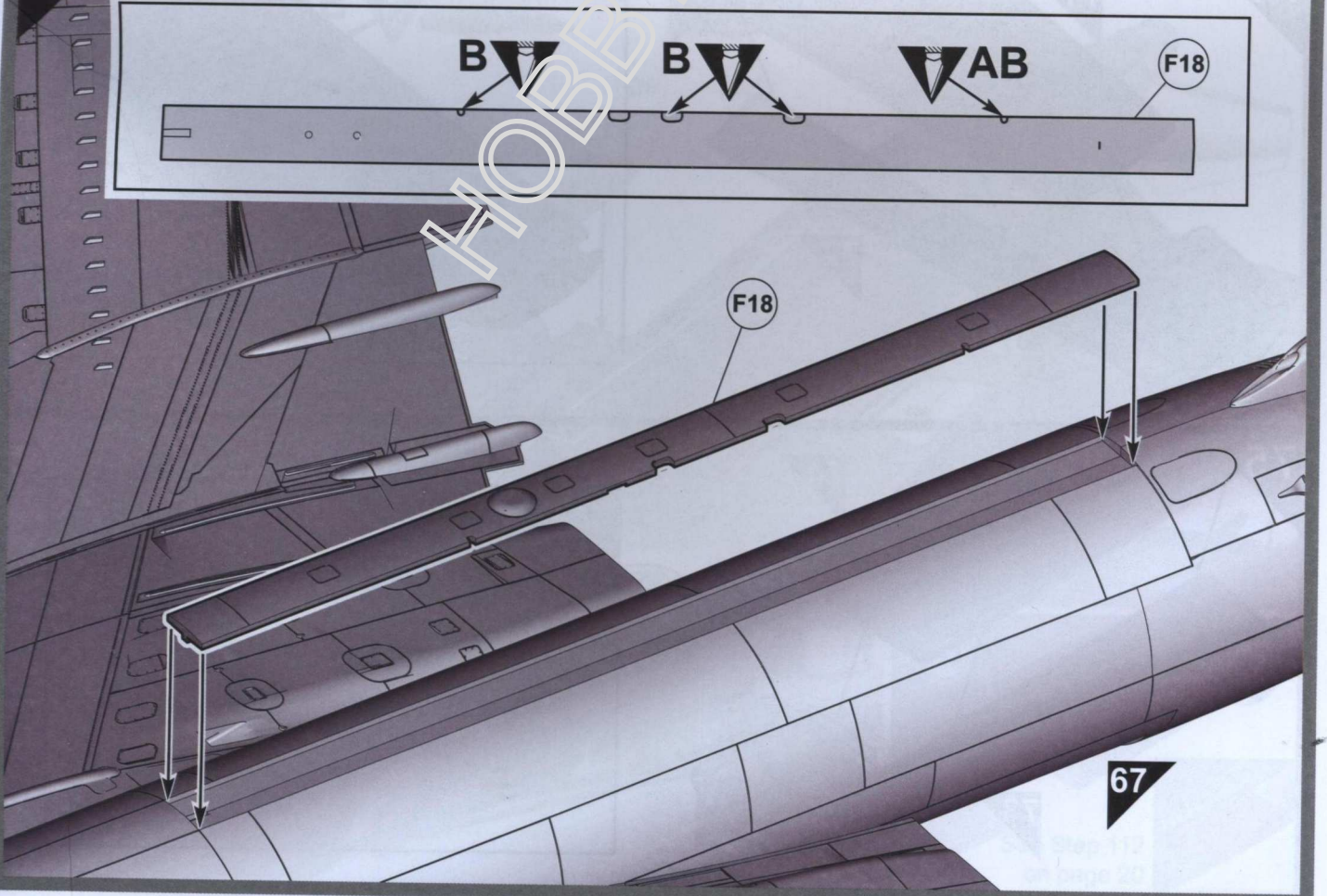

69

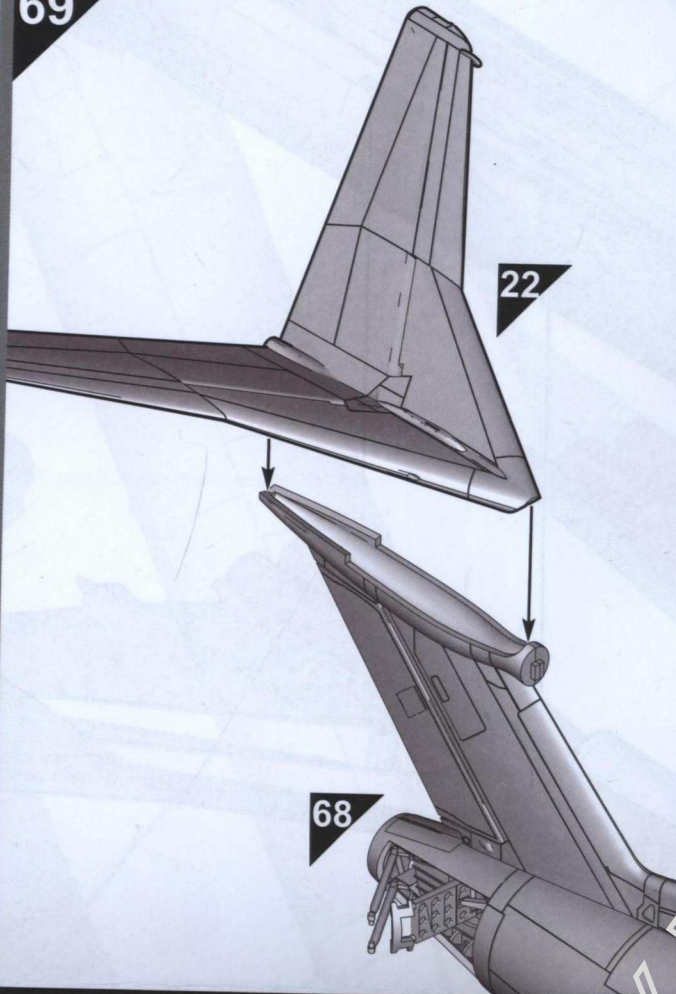

70

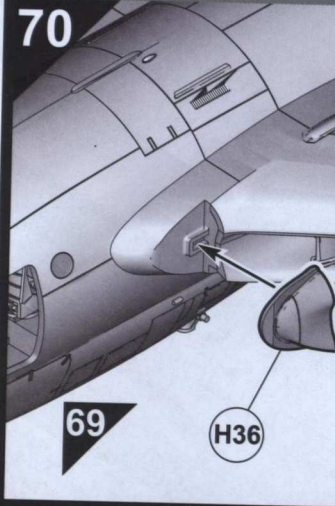

71

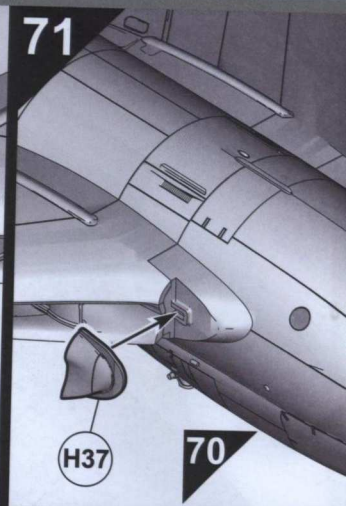

72

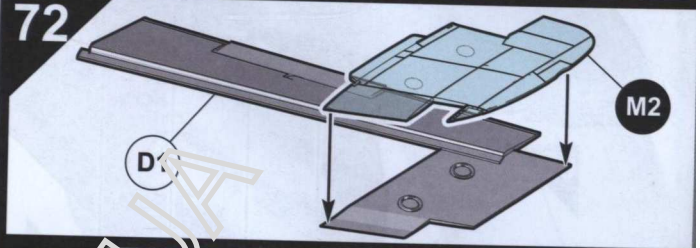

73

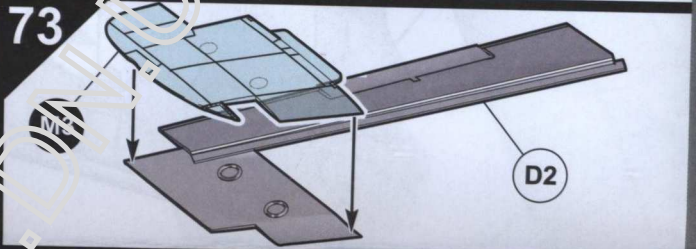

74

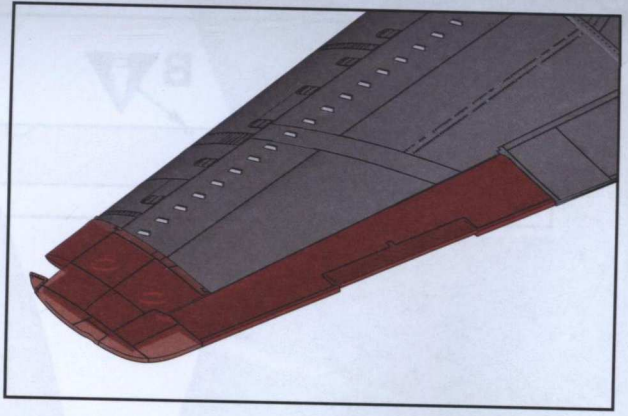
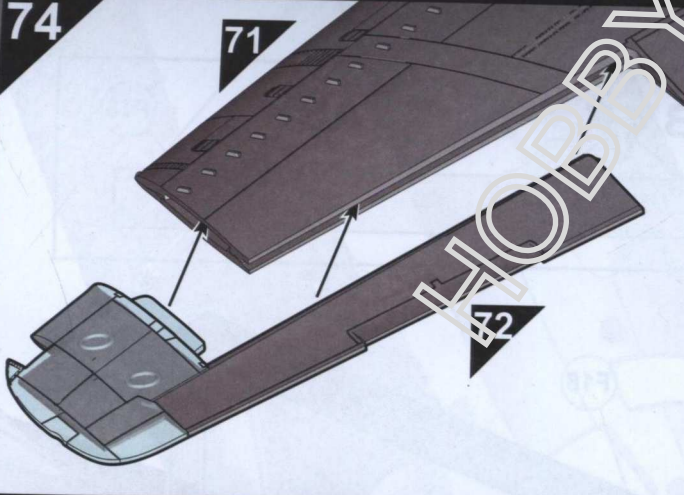

75

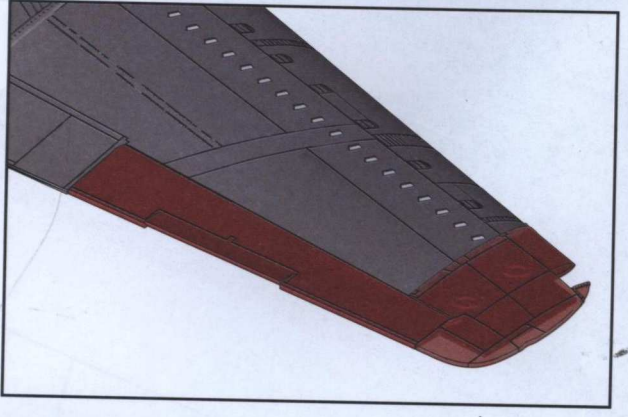
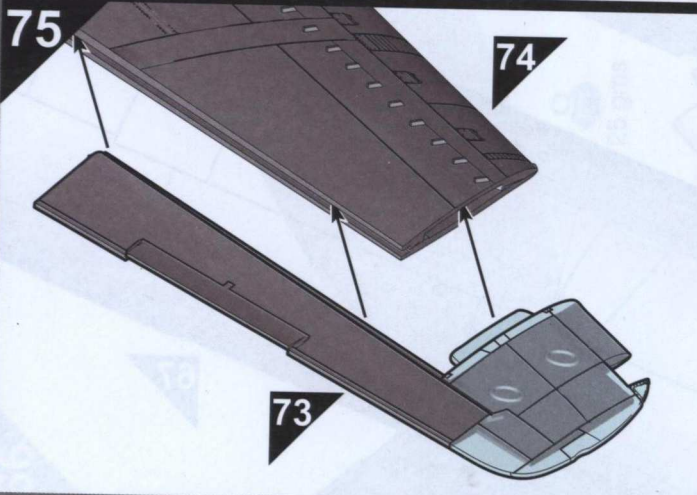

76a

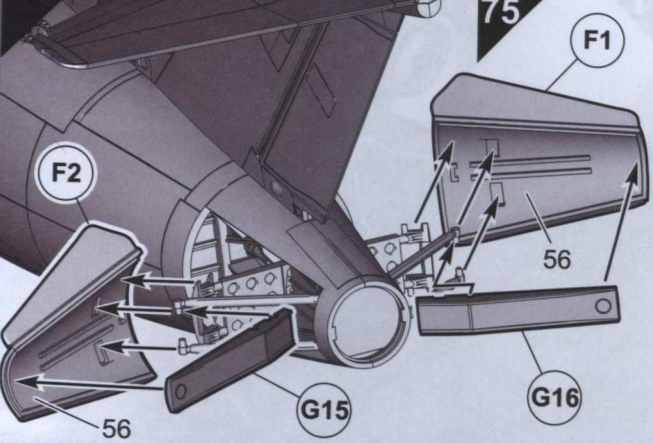

76b

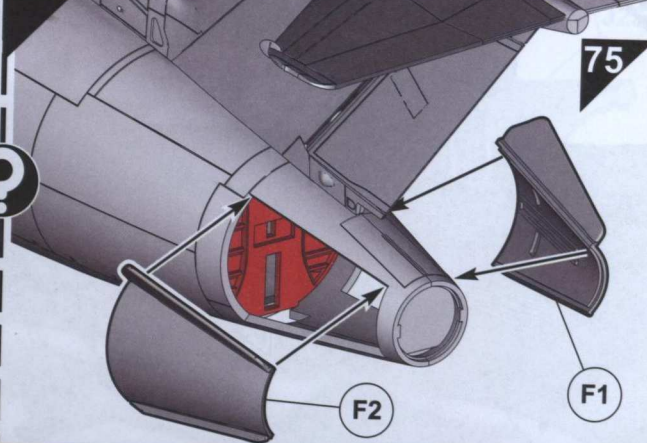

77

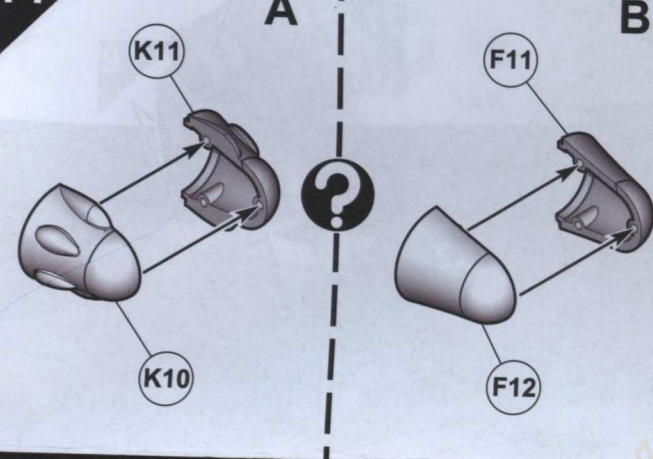

78

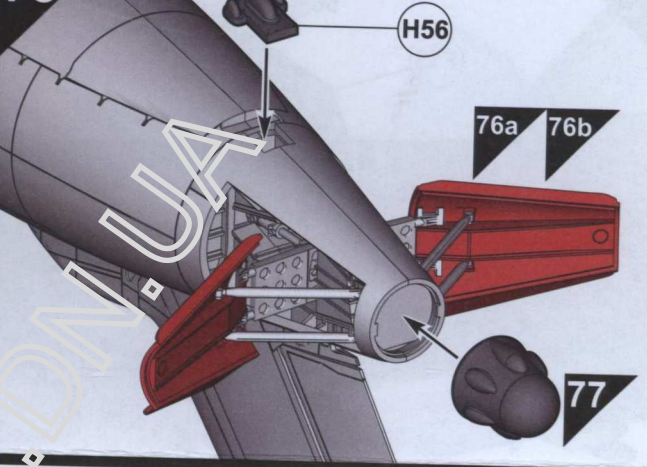

79

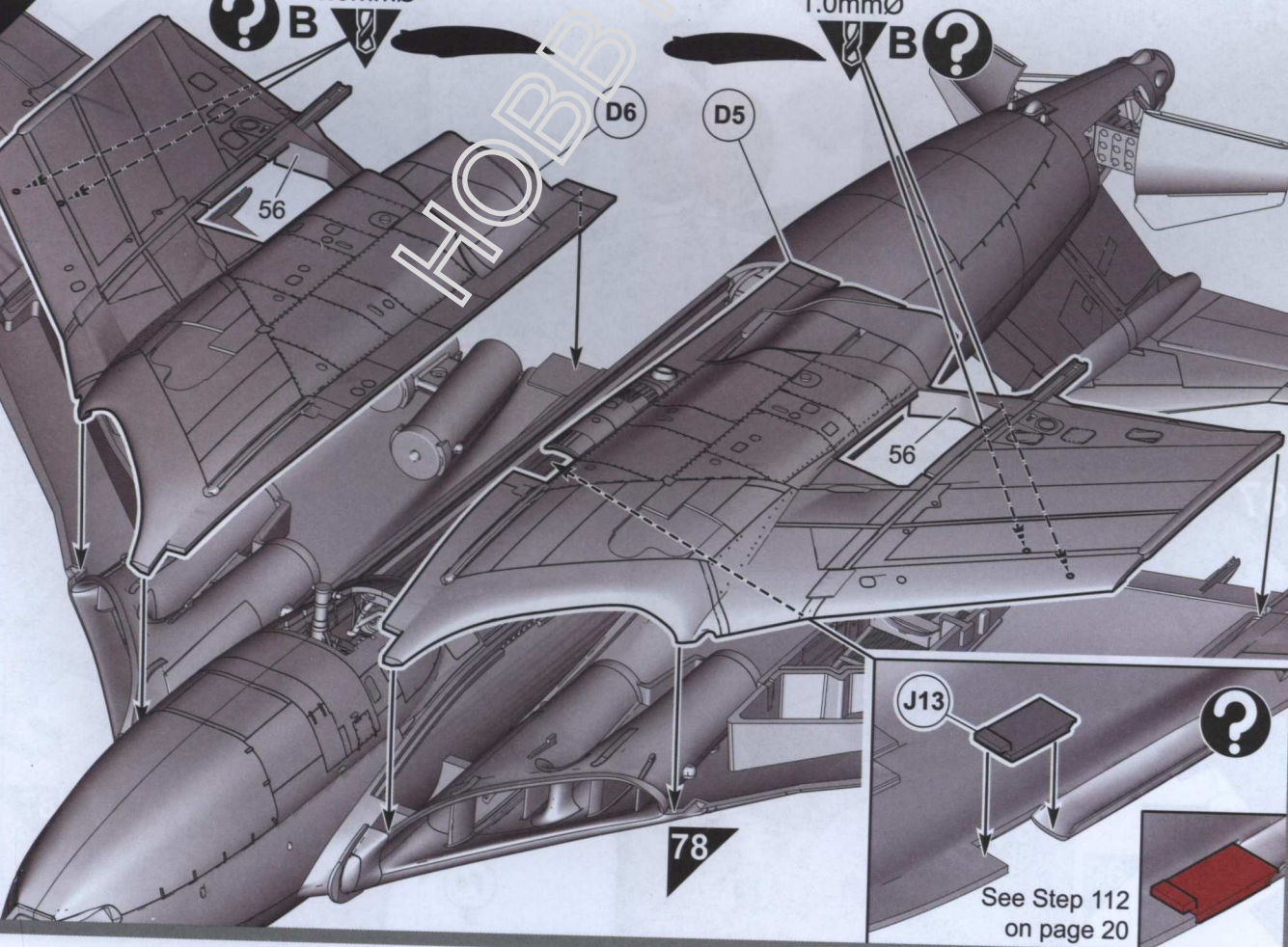

80

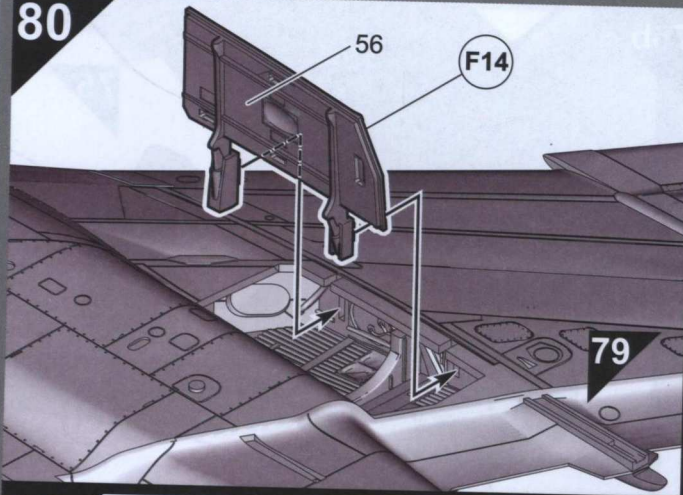

81

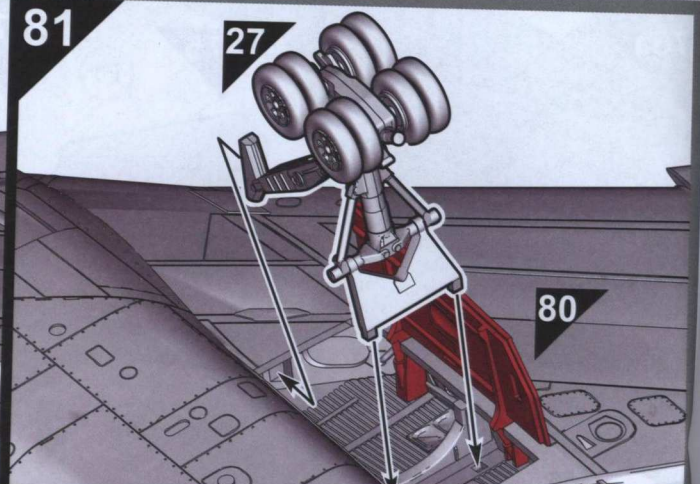

82

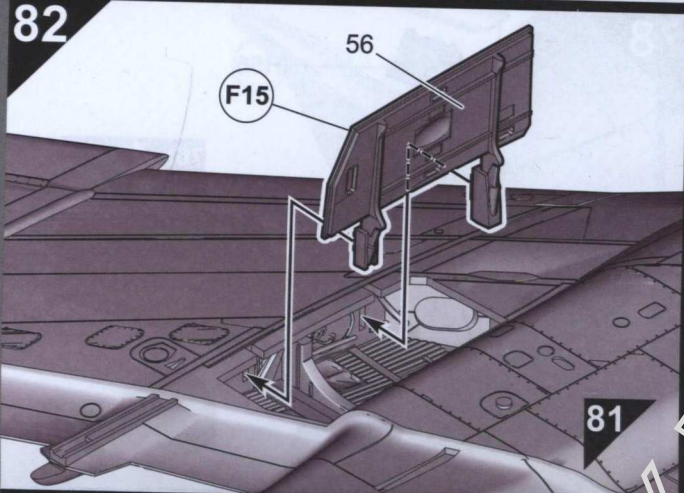

83

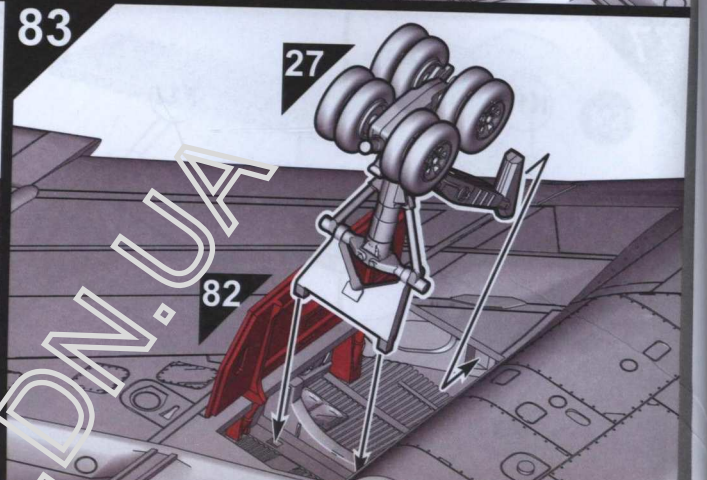

84

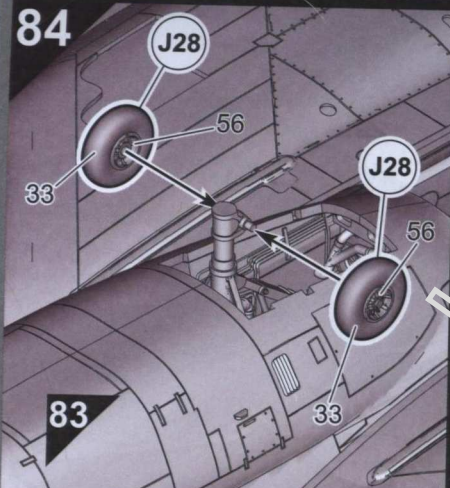

85

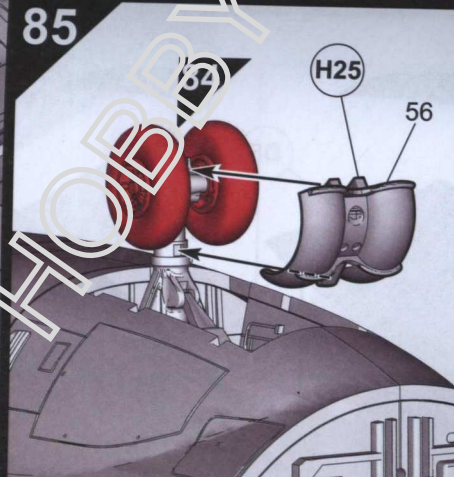

86

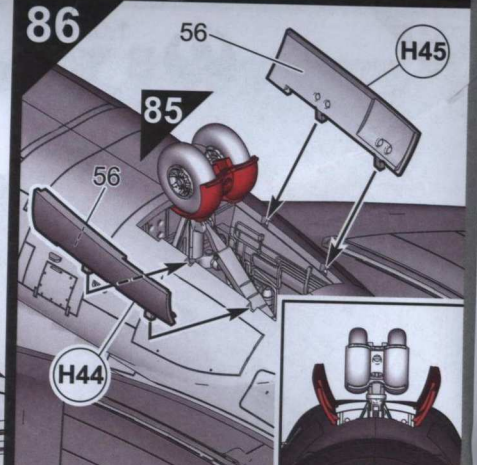

87

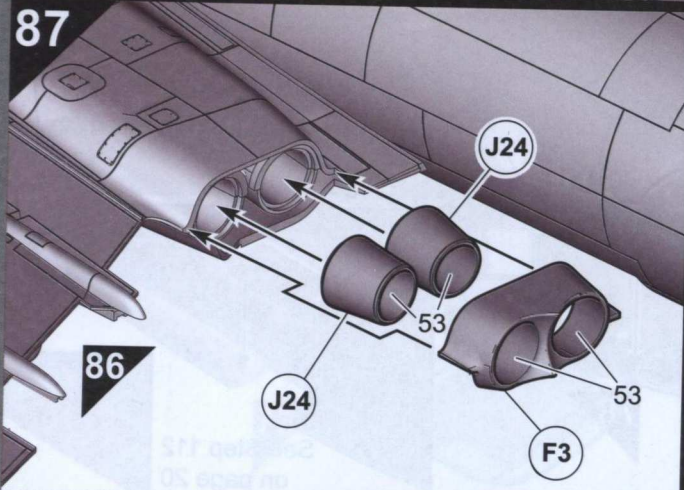

88

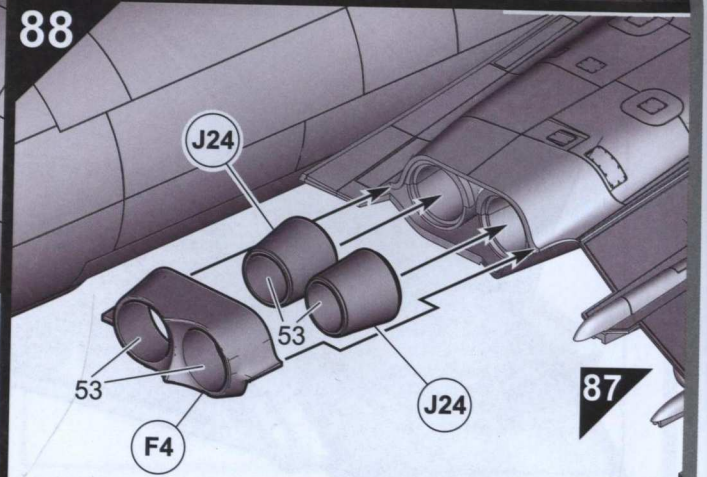

89

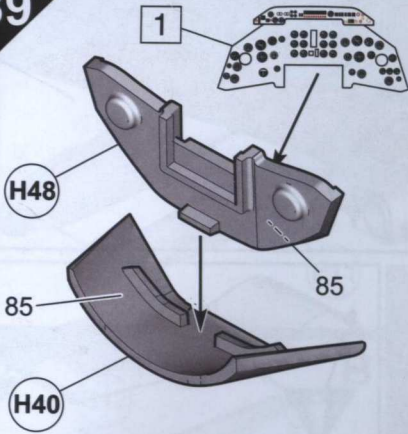

90

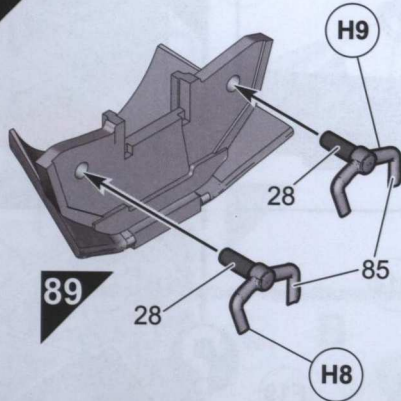

91

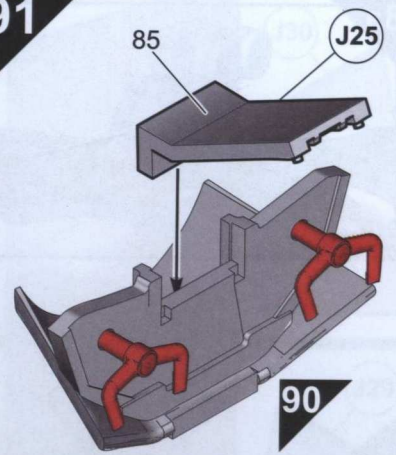

92

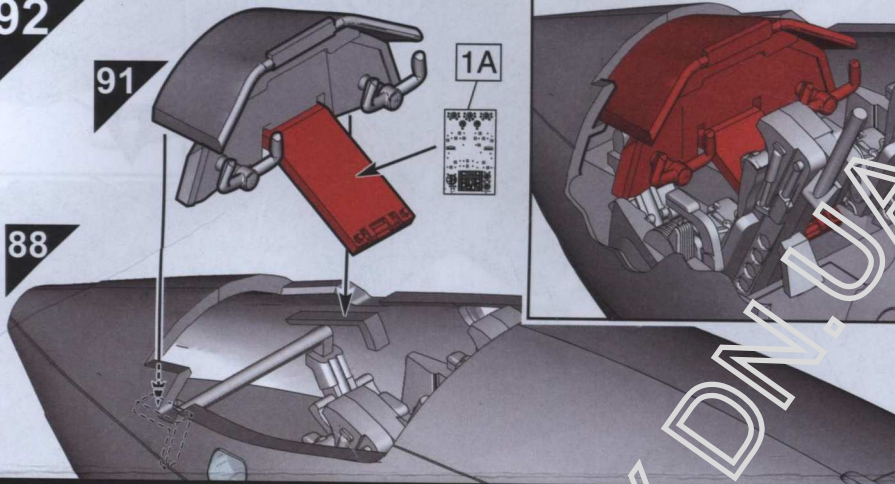

93

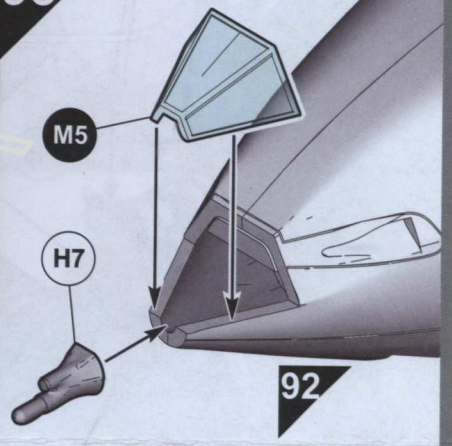

94

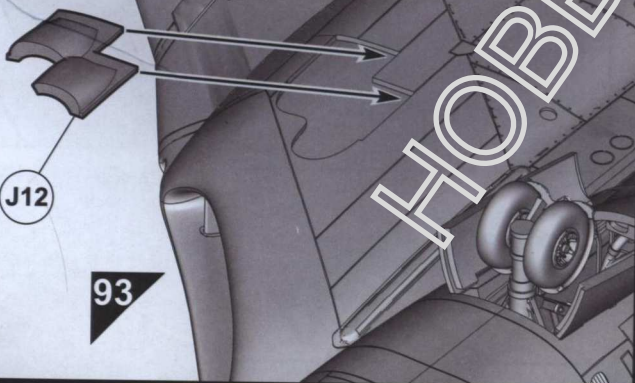

95

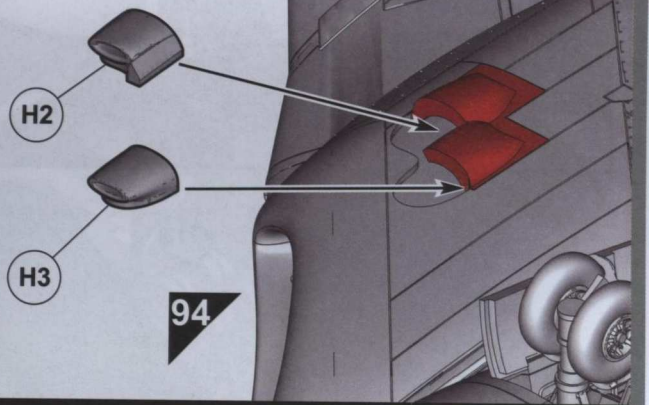

96

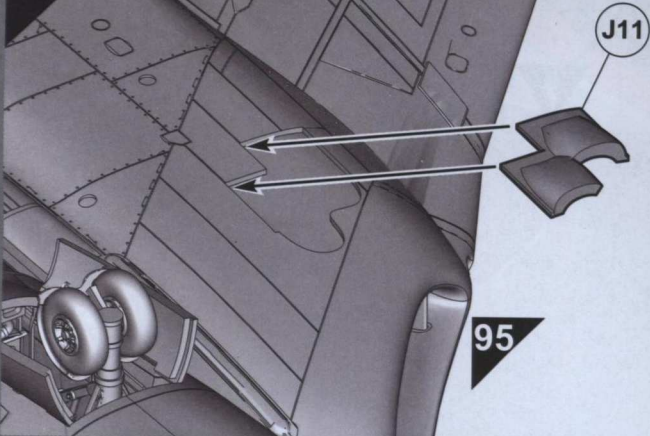

97

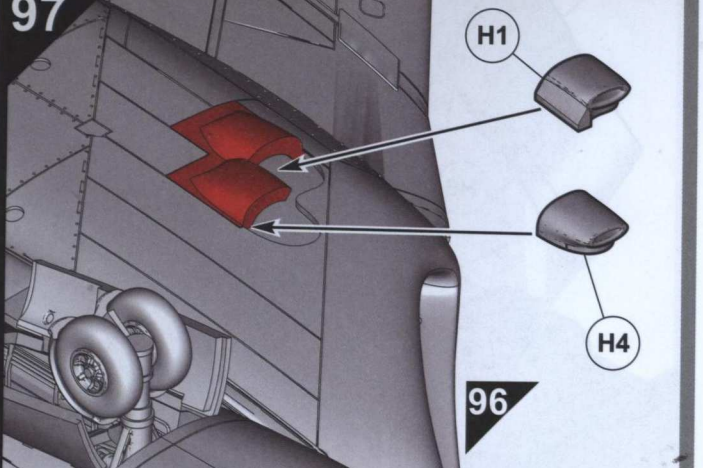

98a

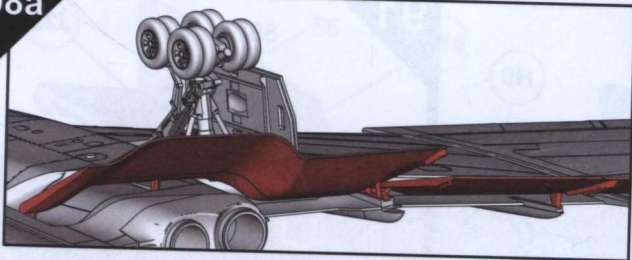

98b

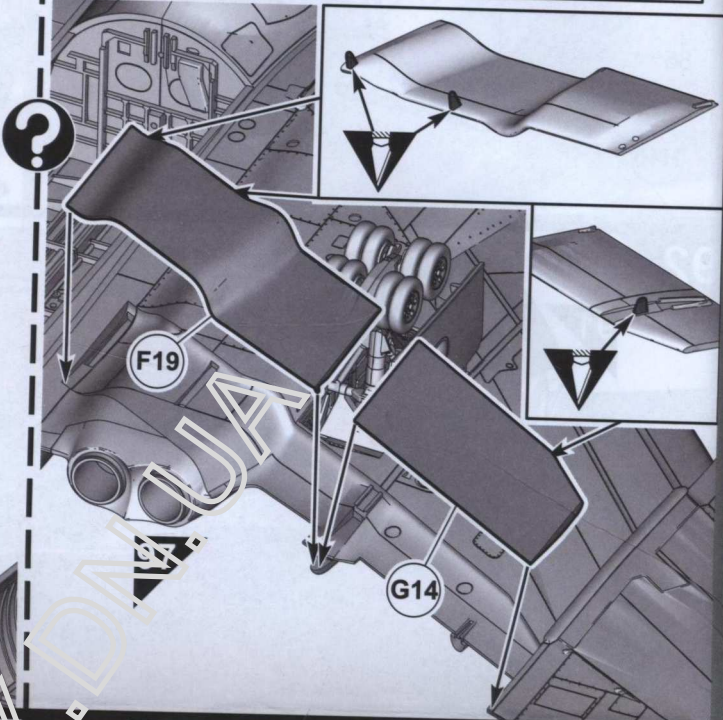
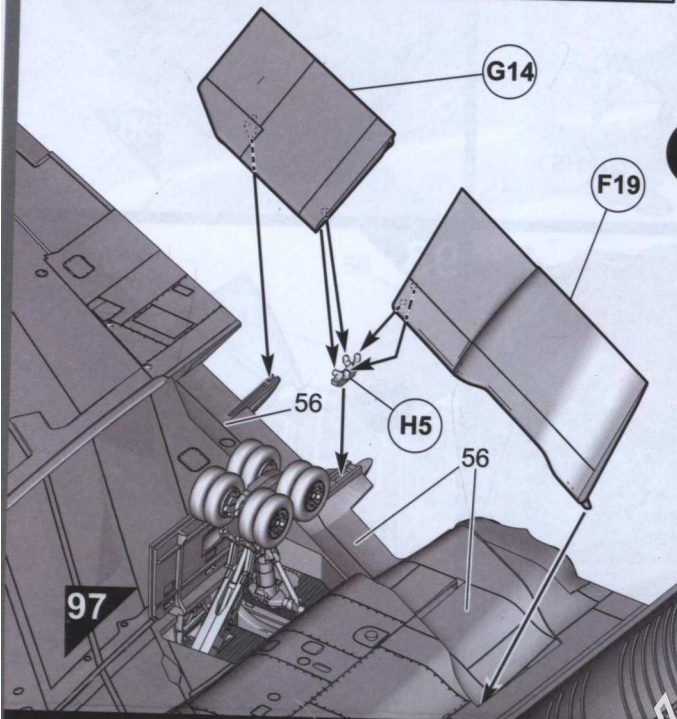
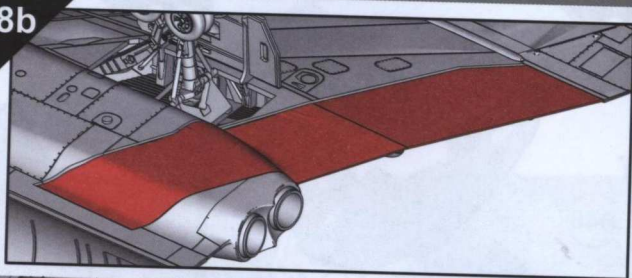

99a

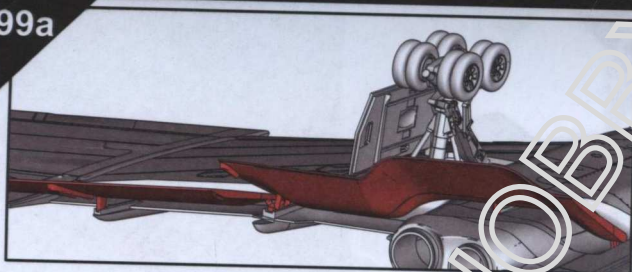

99b

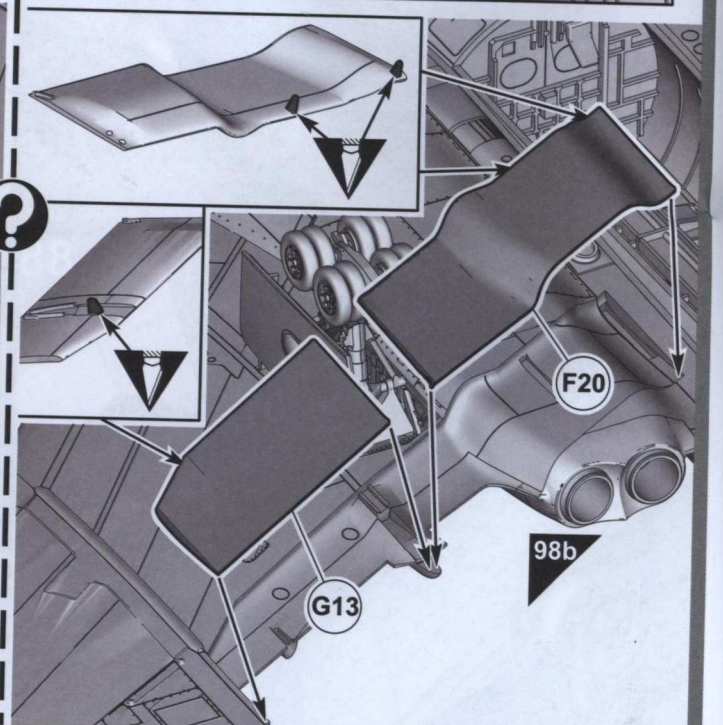
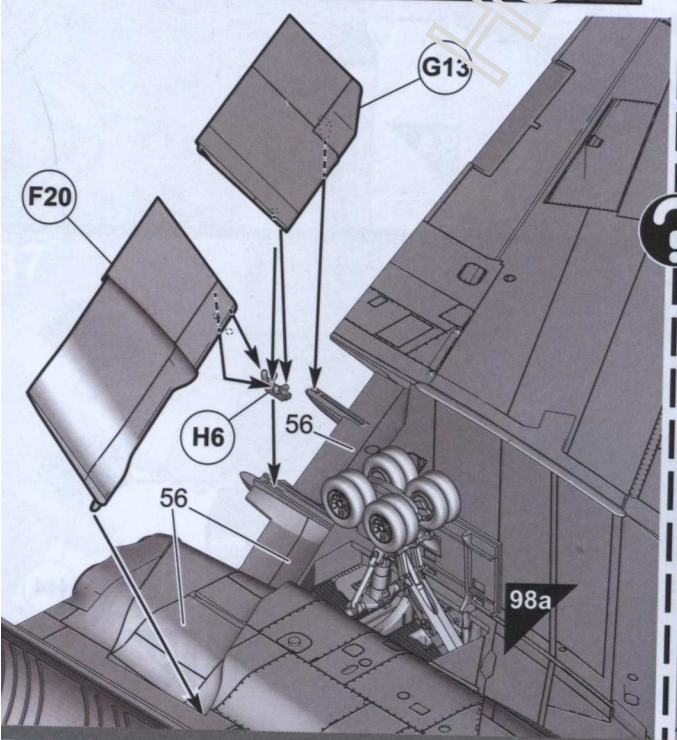
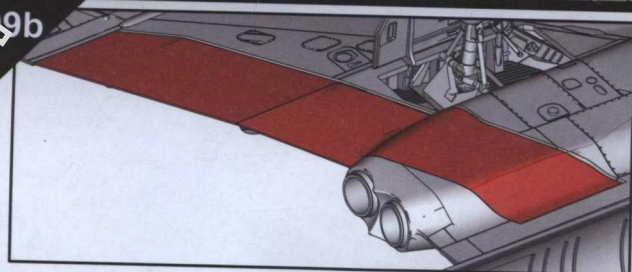

100

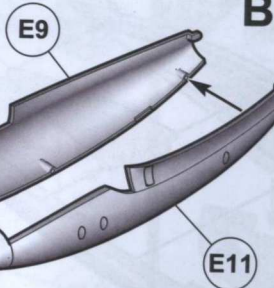

101

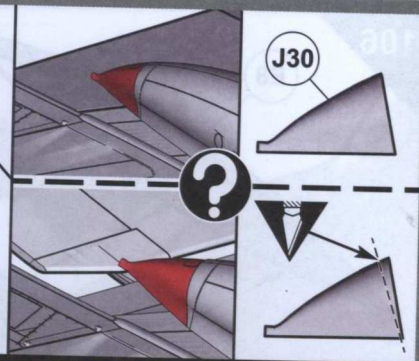
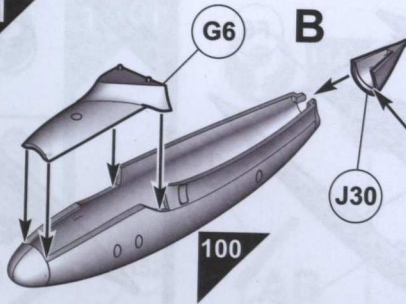

102

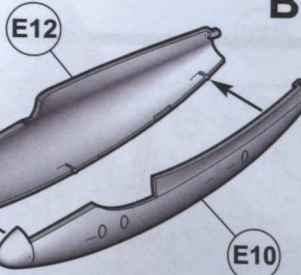

103

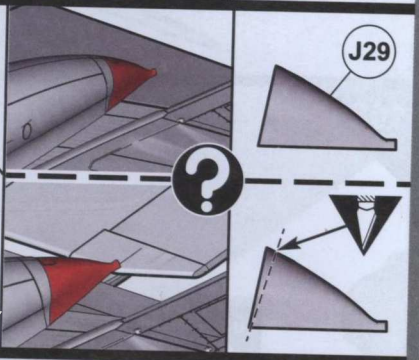
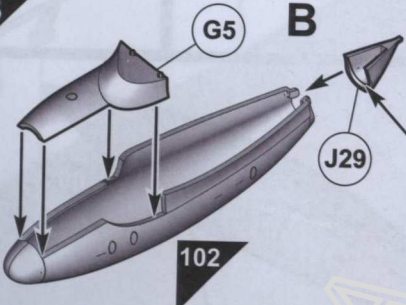

104

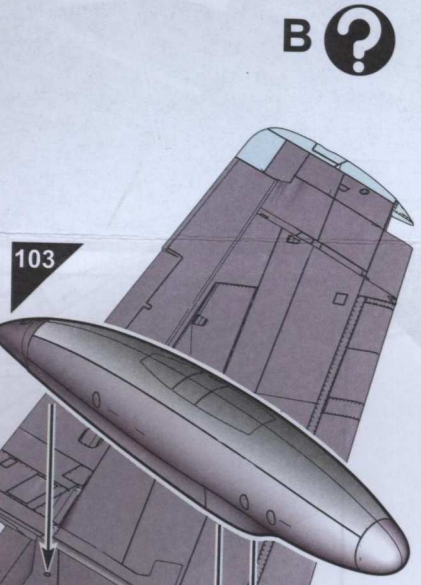
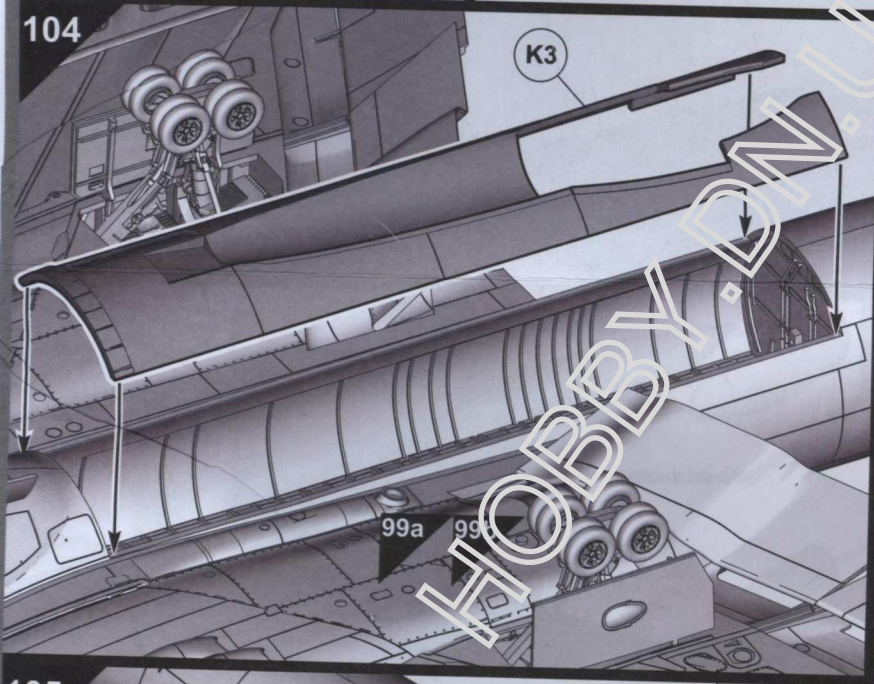

105

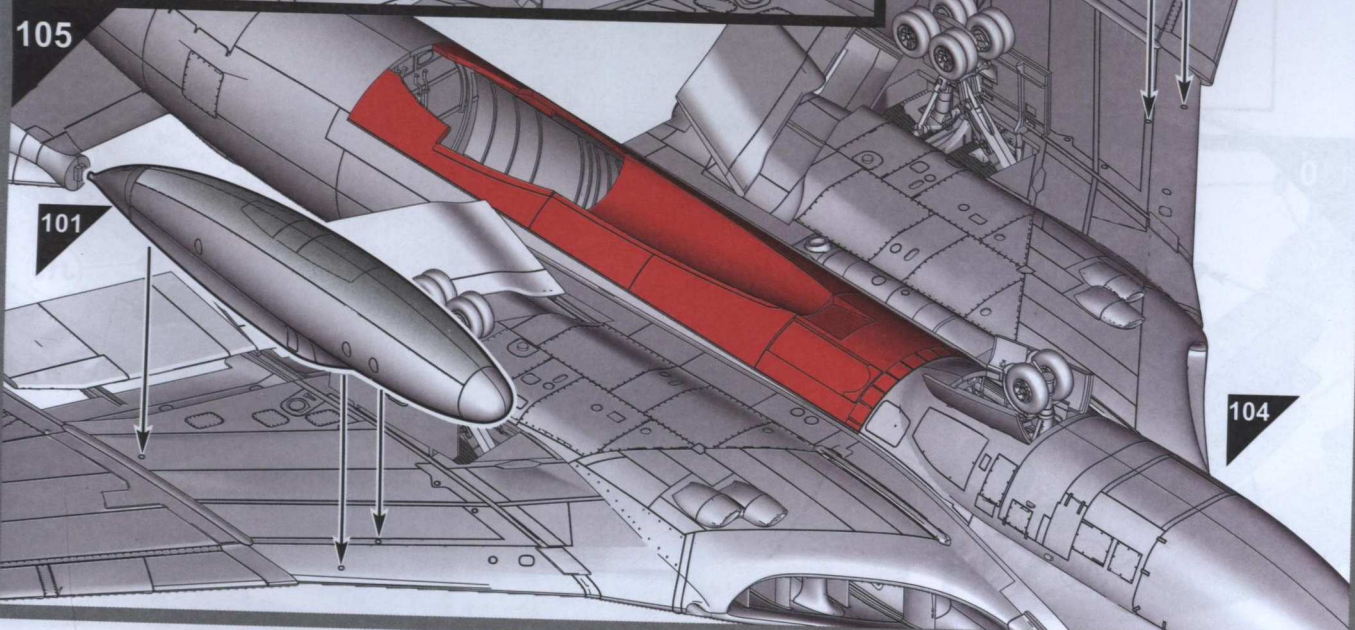

106

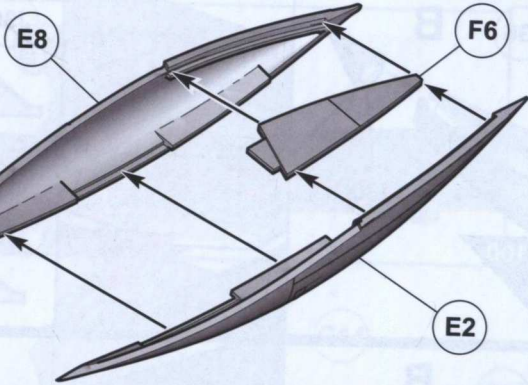

107

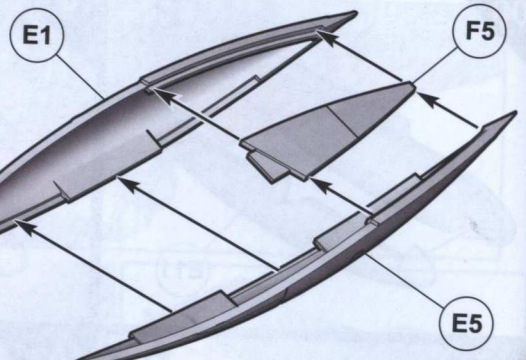

108

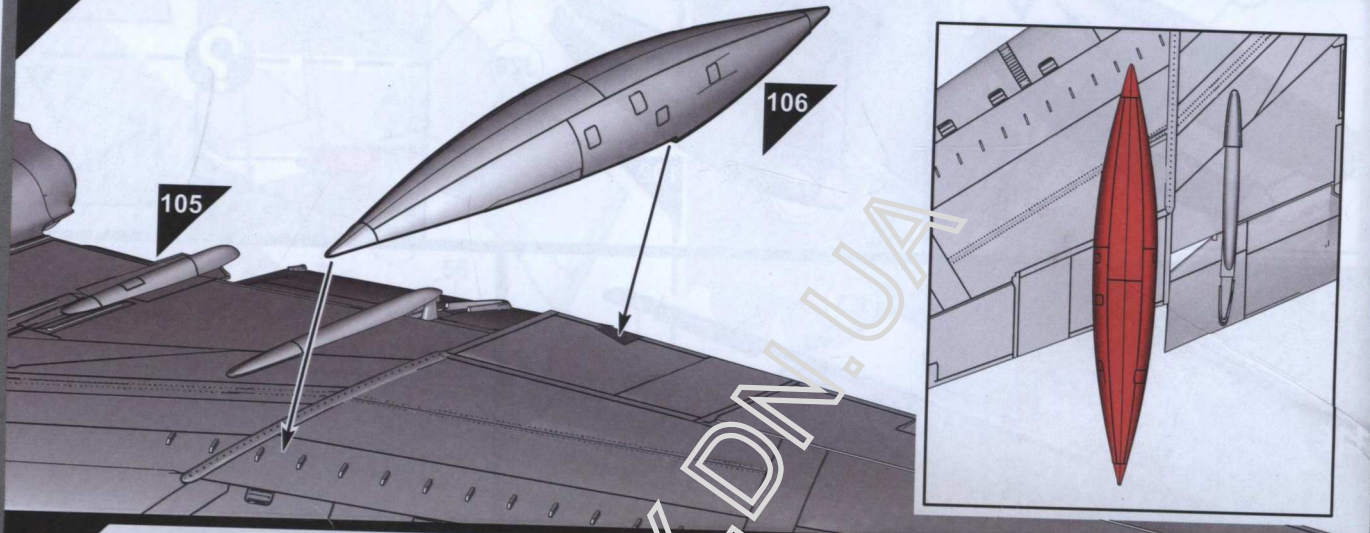

109

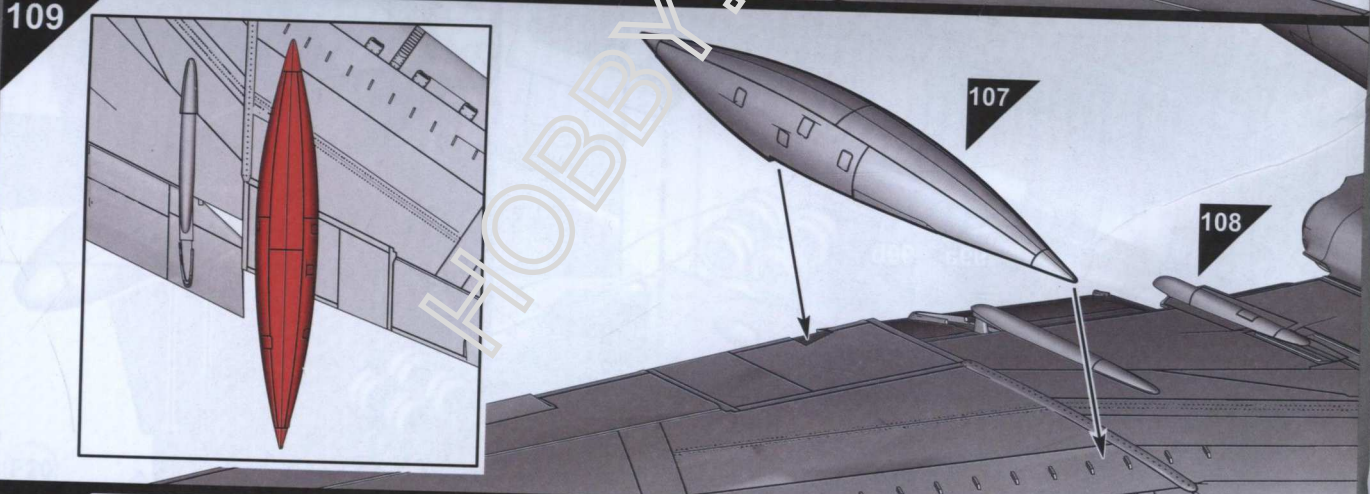

110

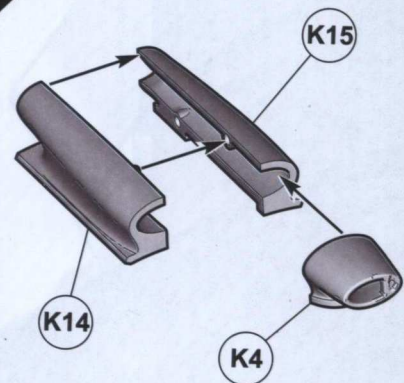

111

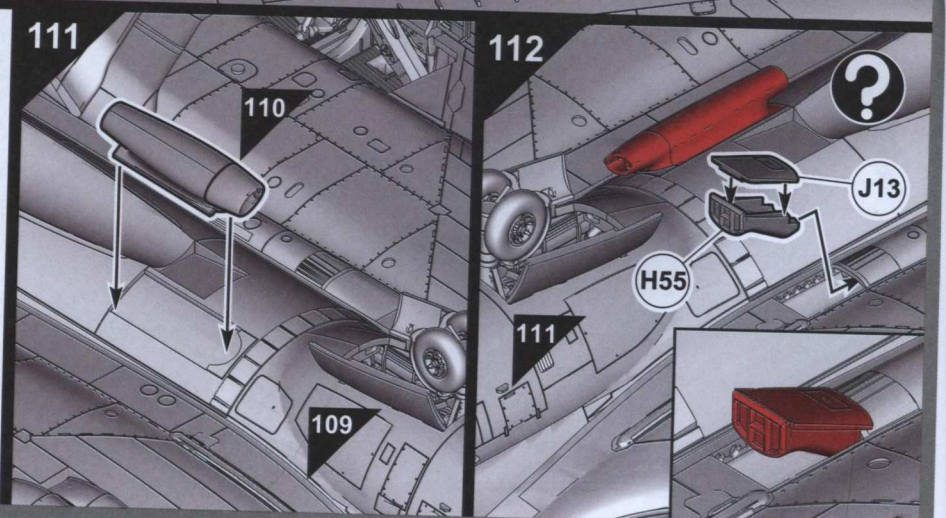

112

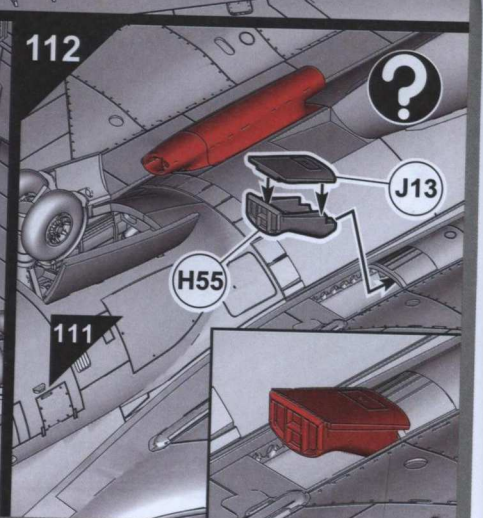

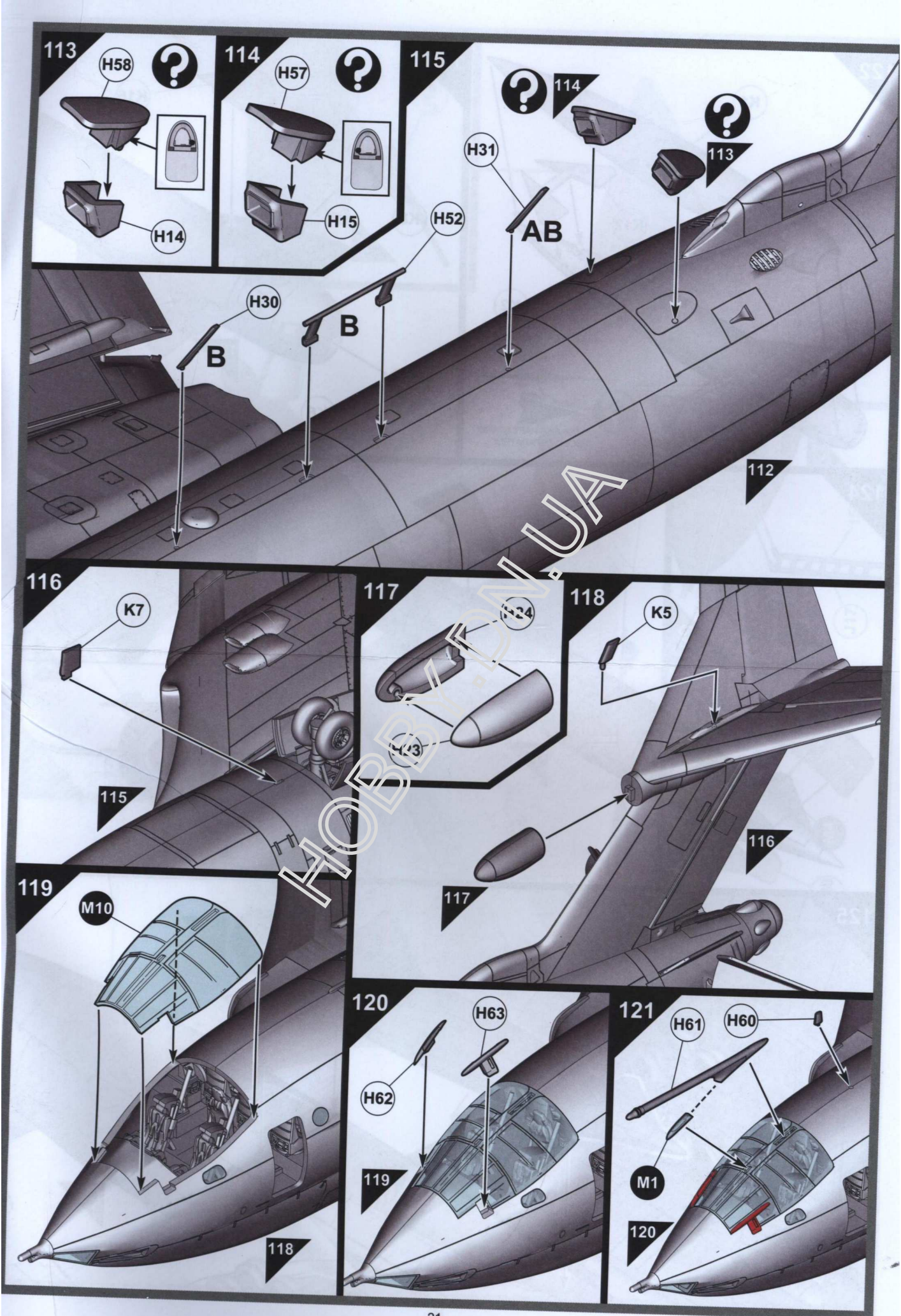

122

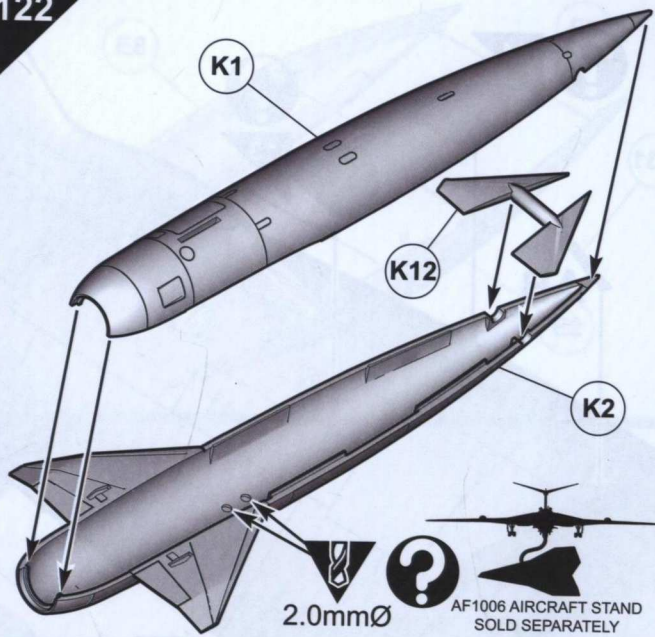

123

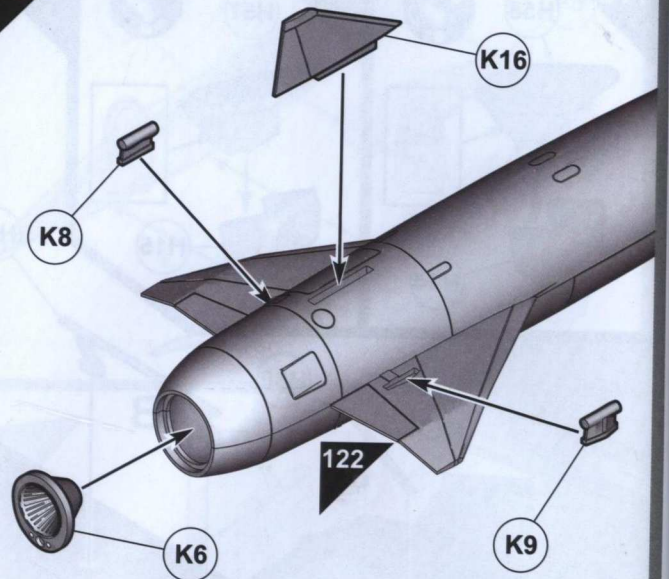

124

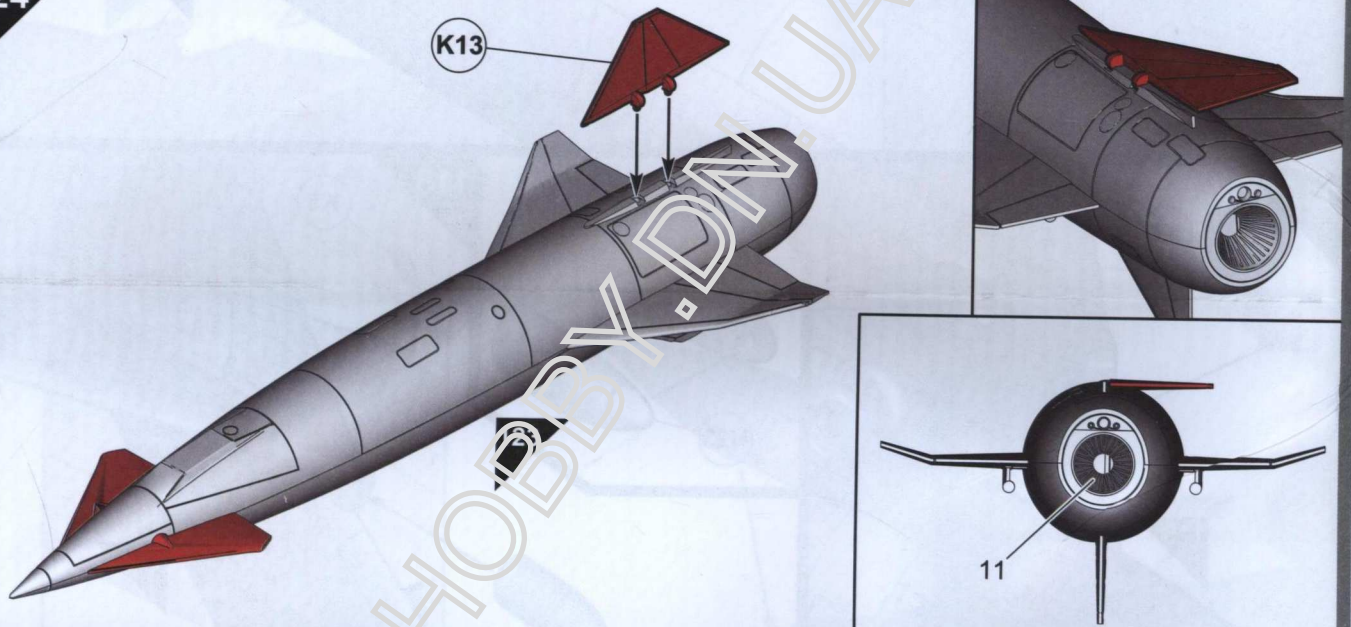

125

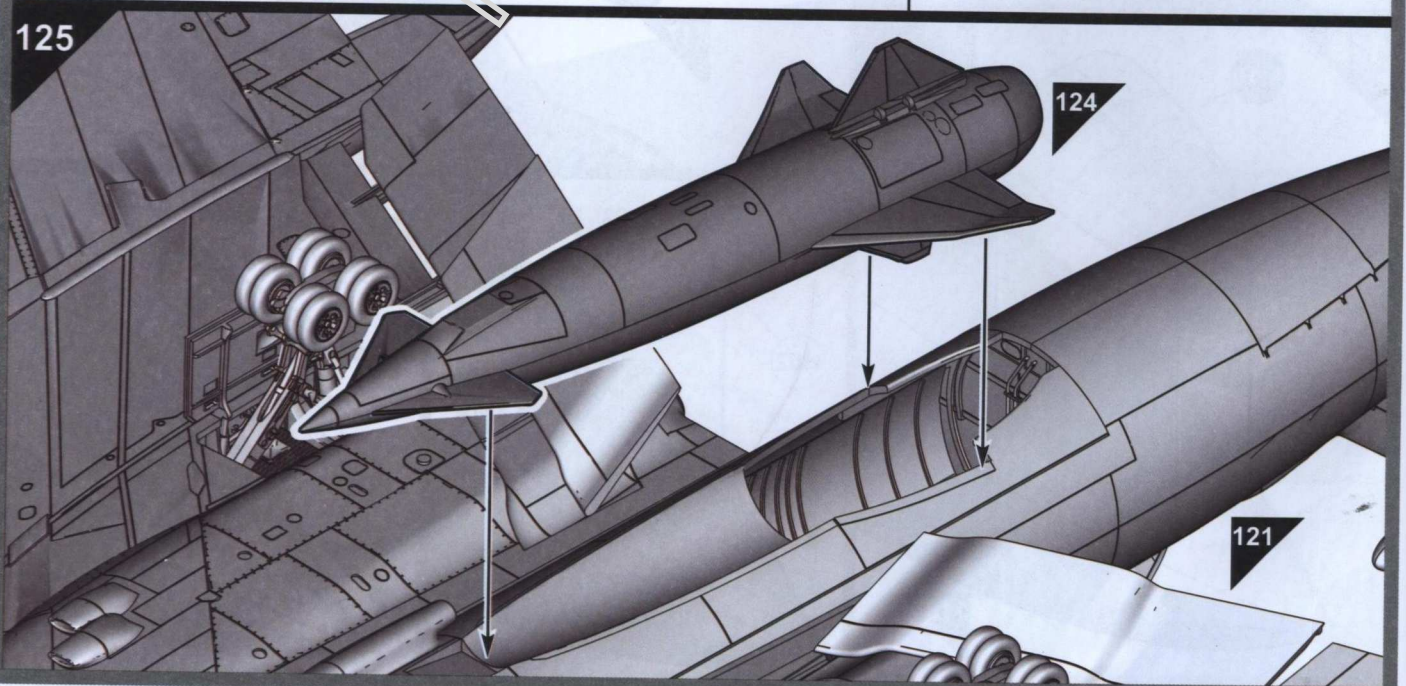

HOBBY.DM.UA

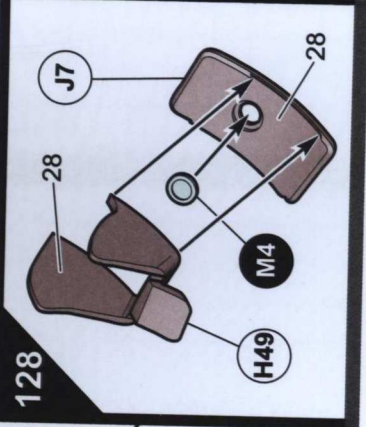
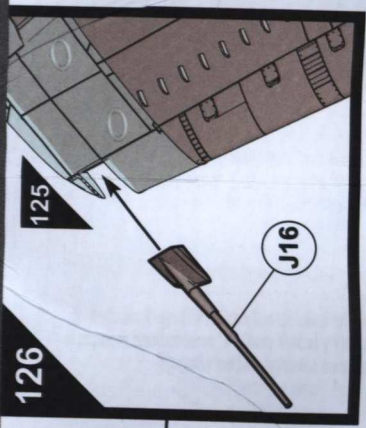
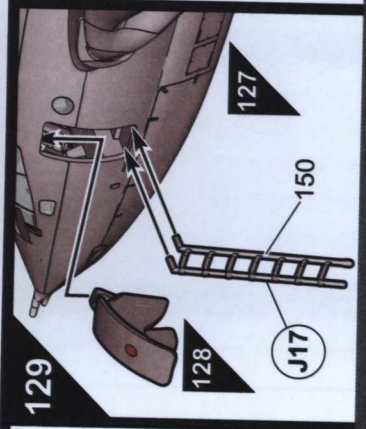
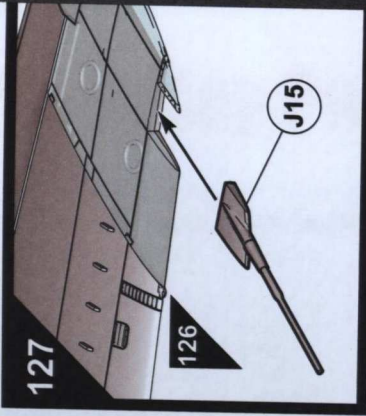
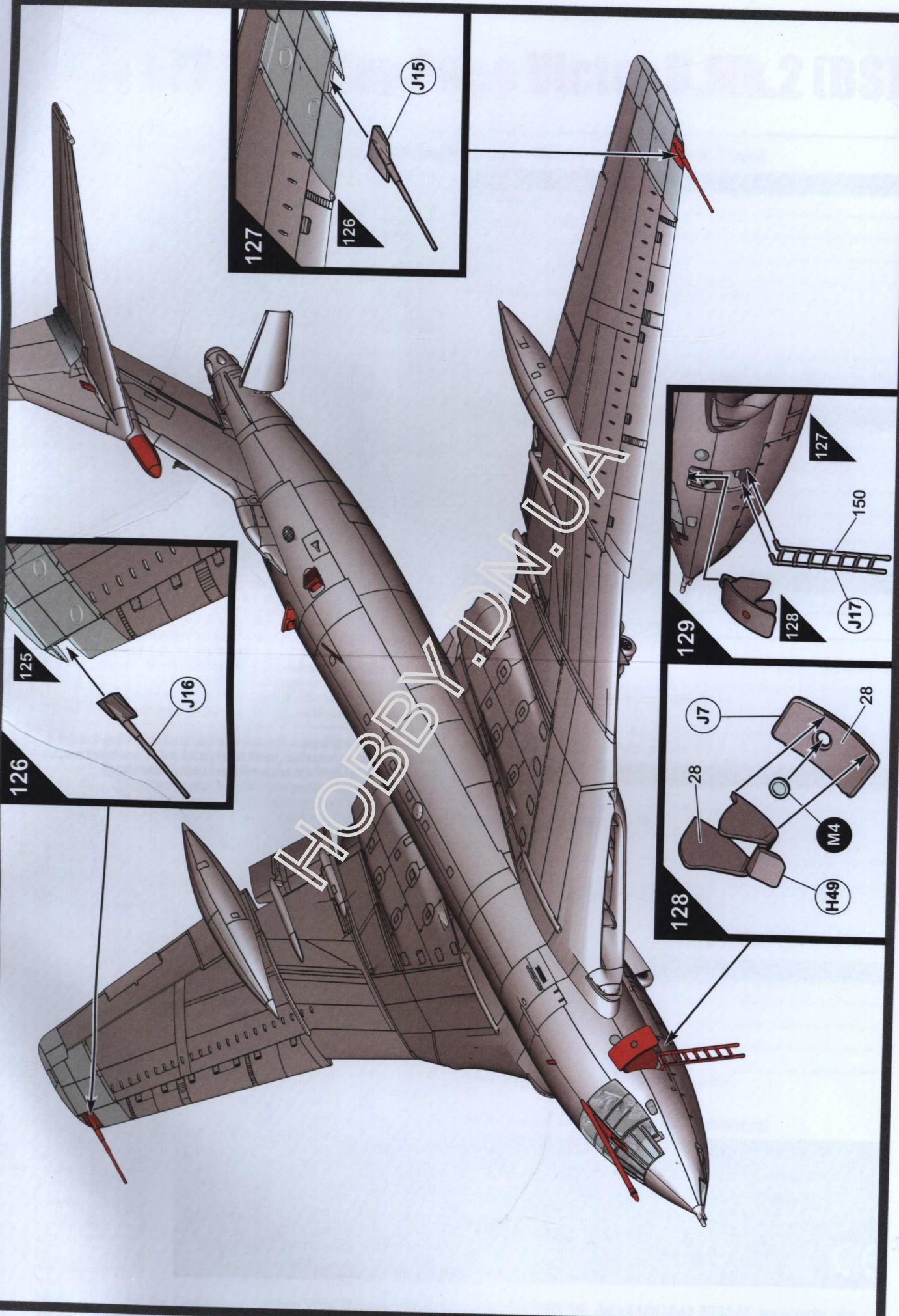

Handley Page Victor B.Mk.2(BS)
 Victor Training Flight, Royal Air Force Wittering, England, 1968.

- | | | | |
|--------------------------|----------------------------------|-----------|-------------|
| 11 | 33 | 53 | 130 |
| Silver | Matte Black | Gun Metal | Satin White |
| 163 | 165 | | |
| Dark Green
BS381C 641 | Medium
Sea Grey
BS381C 637 | | |

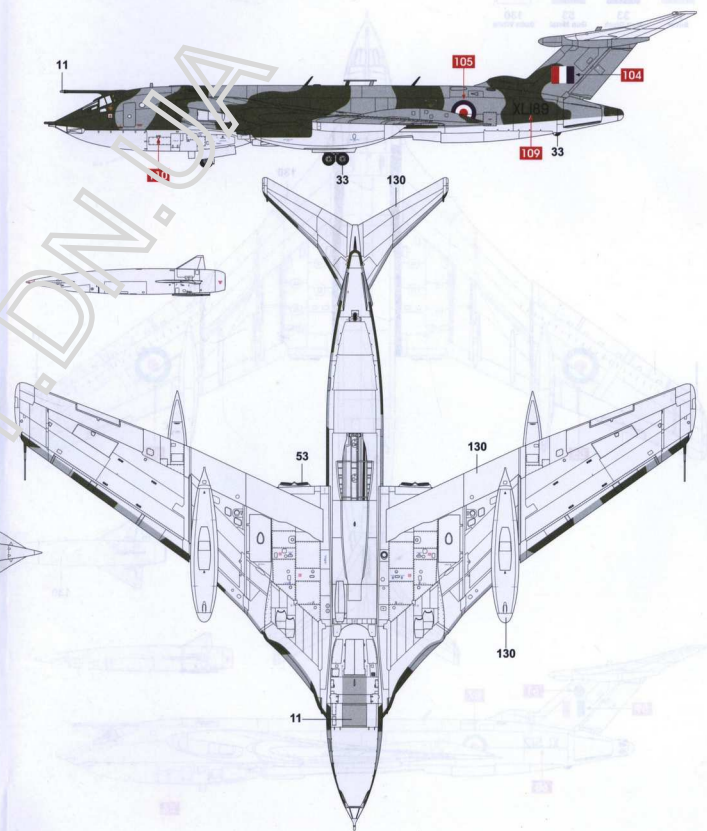

Handley Page Victor B.Mk.2(BS)
 No.139 Squadron, Royal Air Force Wittering, England, 1963-64.

- 11 Silver
- 33 Matt Black
- 53 Gun Metal
- 130 Satin White

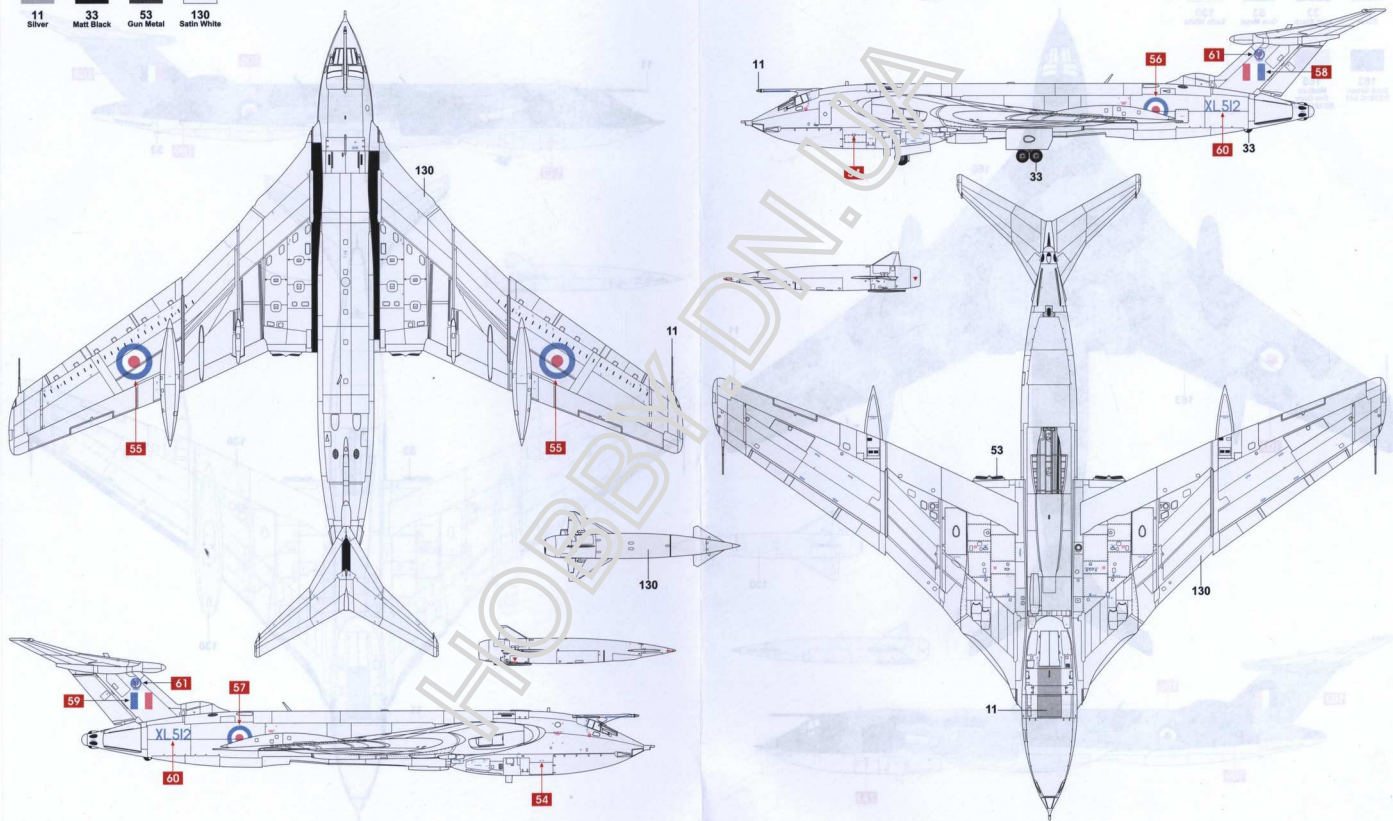

Ⓐ Handley Page Victor B.Mk.2(BS)
Position of stencil data.

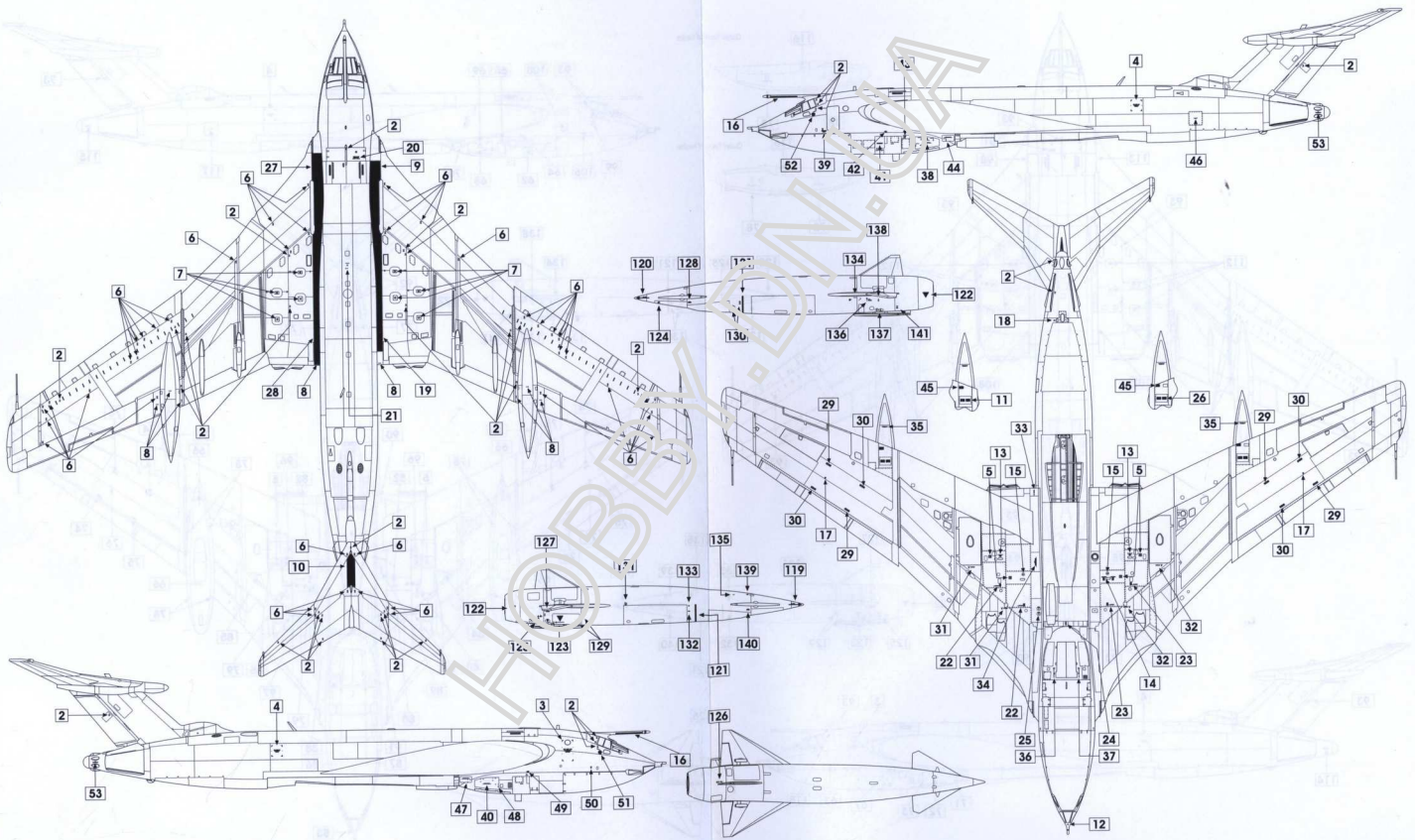

© Handley Page Victor B.Mk.2(BS)
Position of stencil data.

