



# 1:72 Eighth Air Force - Boeing B-17G™ and Bomber Resupply Set

## A12010 SCALE MODEL CONSTRUCTION KIT

**GB** The United States Army Air Force (USAAF) Eighth Air Force was created during World War II to support the Allied invasion of German occupied Europe by flying day-time strategic bombing missions from bases in Eastern England.

By late 1944 the Eighth Air Force's air war over occupied Europe was at its height. Everyday hundreds of Boeing B-17 Flying Fortress and Consolidated B-24 Liberator bombers would head over German held territory, braving flak, German fighters and the weather to deliver bombs onto targets. Damage to returning aircraft was commonplace which often led to the cannibalisation of badly damaged airframes to keep others flying. The silver port wing on the B-17G depicted in this kit is an example of this practice and it is a testament to the skill and hard work of the ground crews that so many aircraft were kept serviceable in this way.

Also included in this set are some of the ground vehicles vital to the refuelling and rearming of the bombers: Autocar U-7144-T 4X4 tractor unit and F-1 fuel trailer. The U-7144-T was used extensively by the US military from 1942 onwards and was certainly found on most, if not all USAAF airfields in Britain, particularly in conjunction with the standard F-1 fuel trailer. With many aircraft requiring refuelling on a daily basis, it was usual for each base to have numerous examples of the U-7144-T available at any one time.

Chevrolet M6 bomb service truck and M5 bomb trailer. This utility 4X4 truck was capable of carrying a small

**FR** La Huitième Armée de l'air américaine (8th USAAF) fut établie pendant la Deuxième Guerre mondiale pour soutenir l'invasion alliée de l'Europe occupée par les Allemands. Elle effectuait des missions de bombardement stratégique de jour à partir de bases dans l'est de l'Angleterre.

À la fin de 1944, la 8th USAAF était au plus fort de son activité au-dessus de l'Europe occupée. Chaque jour, des centaines de bombardiers Boeing B-17 Flying Fortress et Consolidated B-24 Liberator survolaient le territoire défendu par les Allemands, tout en bravant le tir antiaérien, les chasseurs ennemis et les intempéries pour larguer des bombes contre leurs cibles. De retour, les composants des cellules endommagées durent souvent être récupérés pour permettre l'opération d'autres avions. L'aile gauche argentée du B-17G illustré dans ce coffret en est un exemple typique, témoignant des compétences et du travail acharné des équipes au sol qui maintenaient en service tant d'appareils de cette façon.

De plus, ce coffret contient quelques véhicules terrestres essentiels au ravitaillement et au réarmement des bombardiers :

Tracteur Autocar U-7144-T 4X4 et remorque à carburant F-1. À partir de 1942, les forces armées américaines utilisaient beaucoup les U-7144-T qui se trouvaient sur la plupart des aérodromes USAAF en Grande-Bretagne, surtout avec la remorque à carburant F-1 standard. Chaque base aérienne disposait habituellement de plusieurs exemplaires du tracteur U-7144-T disponible à tout moment car de nombreux avions avaient besoin d'être ravitaillés quotidiennement.

**DE** Die United States Army Air Force (USAAF) Eighth Air Force wurde im Zweiten Weltkrieg als Teilstreitkraft zur Unterstützung der Alliierten Invasion der von Deutschland besetzten Gebiete in Europa geschaffen. Zu diesem Zweck wurden strategische Bombenangriffe von Luftstützpunkten im Osten von England aus geflogen.

Ende 1944 waren die Luftkämpfe der Eighth Air Force im besetzten Europa dann auf ihrer Höhe. Tag für Tag flogen damals vor allem schwere Bomber vom Typ Boeing B-17 Flying Fortress und Consolidated B-24 Liberator über deutsche Machtgebiete, wo sie oft heftigem Flakfeuer, Jagdflugzeugen der Wehrmacht und dem Wetter ausgesetzt waren, um dort Bomben möglichst zielgenau abzuwerfen. Beim Rückflug wurden die Flugzeuge daher häufig beschädigt. Deshalb mussten schwerbeschädigte Flugwerke oft als Ersatzflieger benutzt werden, um leichter zu Schaden gekommene Maschinen wieder flugtauglich zu machen. Die in diesem Bausatz wiedergegebene silberne Tragflächenhälfte einer B-17G dient als Beispiel dafür. Sie repräsentiert die Fähigkeiten und hohen Leistungen der Bodenmannschaften, die dazu sorgten, dass die Flugzeuge einsatzbereit halten konnten.

Außerdem enthält dieses Set Modelle von Bodenfahrzeugen, die zum Auftanken sowie auch zu Beladung mit Waffen der Bomber entscheidend waren:

Autocar U-7144-T 4X4 Zugmaschine und F-1 Kraftstofftrailer. Die Amerikaner setzten ab 1942 Zugfahrzeuge vom Typ U-7144-T ein, die bald auf den meisten wenn nicht allen USAAF-Flugfeldern in Großbritannien zu finden waren, ganz besonders in Verbindung mit dem normalerweise damit verwendeten F-1 Kraftstofftrailer.

Airfix would like to express their thanks to IWM Duxford, The Smithsonian, Lynn Ritger, Jon Brawner, Karl Hauffe, Roy Sutherland and Jan Zdiarský for their help with the development of this product.



**B-17 Flying Fortress™**

Produced under License. Boeing, B-17 Flying Fortress, the distinctive Boeing logos, product markings and trade dress are trademarks of The Boeing Company.



### FOR BEST RESULTS:

Surfaces to be painted should be clean — before parts are removed from the sprue, wash in warm, soapy water, rinse and dry thoroughly. Stir paints thoroughly before use.

### PLEASE NOTE:

Some parts in the kit may not be required to build the model specified.



number of bombs in its own right, but was more commonly used in conjunction with the M5 bomb trailer. Up to five fully loaded M5 bomb trailers could be towed.

Cushman Model 39 Package Car. This light, three wheeled utility vehicle was used for a multitude of light duties on USAAF bases. A development of a motor scooter design, the single wheel at the back provided the power for the vehicle, which allowed a small cargo box to be fitted at the front.

### Specification

Maximum Speed: 287 mph (462km/h)

Range: 2,000 miles (3,219 km)

Wingspan: 103 ft 9 in (31.67m)

Length: 74 ft 9 in (22.83 m)

Armament: 13 x .50 in (12.7mm) Browning machine guns (2 in the chin turret, 2 on nose cheeks, 2 staggered waist guns, 2 in the upper Sperry turret, 2 in the ball turret, 2 in the tail and one in the radio compartment). 8000 lb of bombs

Camion de service porte-bombes Chevrolet M6 4X4 et remorque à bombes M5. Ce camion était capable de lui seul de transporter un petit nombre de bombes mais il était plus communément utilisé avec la remorque à bombes M5. Il permettait de transporter jusqu'à cinq remorques à bombes M5 en pleine charge.

Véhicule utilitaire léger Cushman Model 39 à trois roues. Développé d'une conception de scooter motorisé et utilisé pour de nombreux travaux sur les bases aériennes USAAF, ce véhicule était propulsé par sa seule roue arrière ce qui permettait de charger sur le devant d'une petite boîte à cargaison.

### Spécification:

Vitesse maximale: 462 km/h

Autonomie: 3 219 km

Envergure: 31,67 m

Longueur: 22,83 m

Armement: 13 mitrailleuses Browning de 12,7 mm dont deux dans la tourelle de menton, deux de 'joue' montées sur chaque côté du nez, deux sans les sabords latéraux, deux dans la tourelle supérieure Sperry, deux dans la tourelle ventrale, deux à l'arrière et une à l'emplacement du poste radio. 3.630 kg de bombes

Da viele Flugzeuge täglich aufgetankt werden mussten, waren gewöhnlich jederzeit mehrere U-7144-T Zugmaschinen auf jedem Stützpunkt verfügbar.

Chevrolet M6 Bomb Service Truck und M5 Bomb Trailer. Dieses leichte Zugfahrzeug mit Allradantrieb konnte einige Bomben befördern, wurde jedoch meistens zusammen mit dem Bombenkarren M5 verwendet. Dabei konnten bis zu fünf dieser Karren voll beladen gezogen werden.

Cushman Model 39 Package Car. Dieses leichte dreirädrige Nutzfahrzeug wurde auf USAAF-Stützpunkten für vielfältige Aufgaben eingesetzt. Auf einer Motorrollerkonstruktion basiert, sorgte ein hinten angeordnetes Rad für den Antrieb des Fahrzeugs, wobei vorne ein kleiner Transportkasten montiert war.

### Spezifikation:

Höchstgeschwindigkeit: 462 km/h

Reichweite: 3.219 km

Spannweite: 31,67 m

Länge: 22,83 m

Bewaffnung: 13 Browning-Maschinengewehre 12,7 mm (2 im Kinnerturm, 2 an Bugwangen, 2 seitlich versetzt angeordnet, 2 im oberen Sperry-Turm, 2 im Kugelturm, 2 im Heck und 1 im Funkabteil). 3600 kg an Bomben

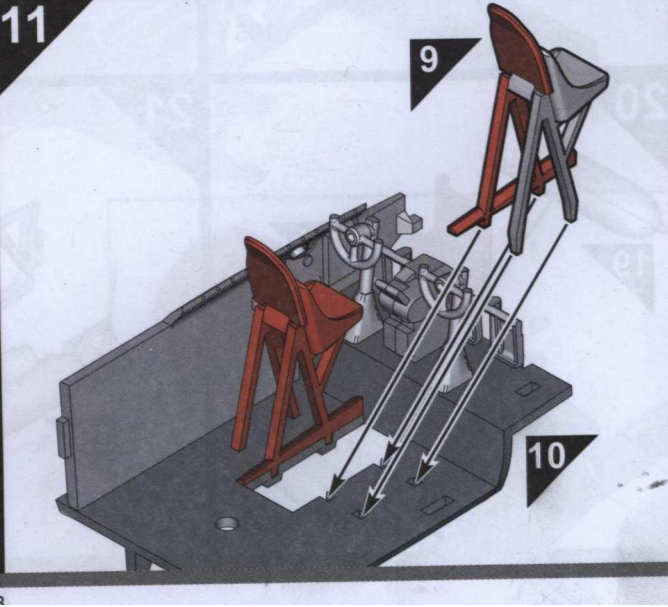
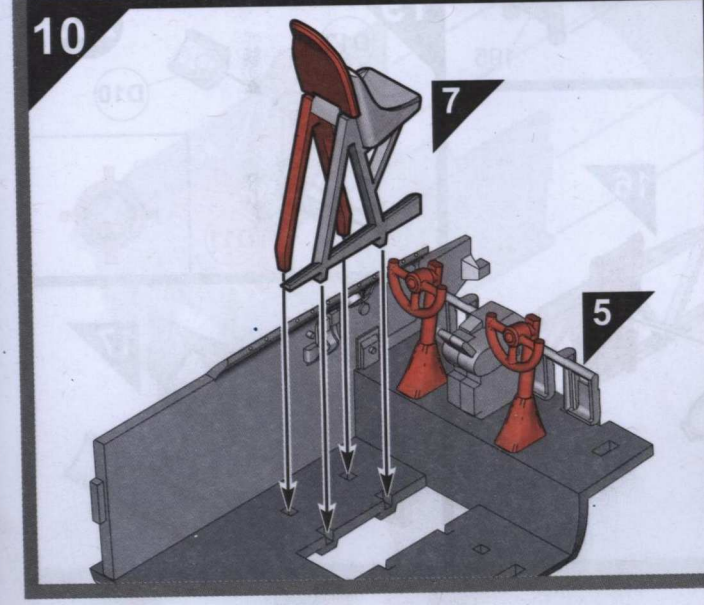
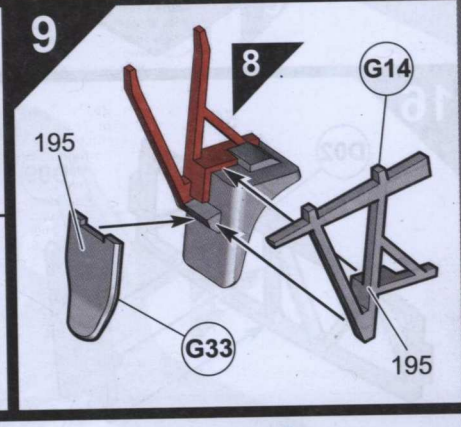
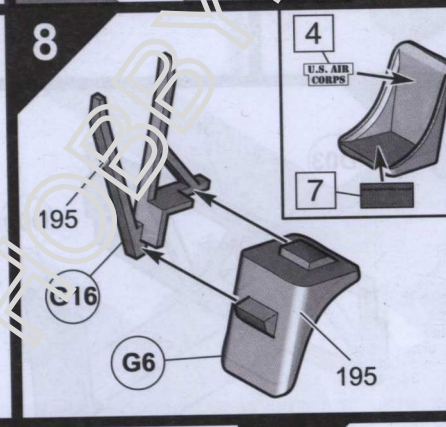
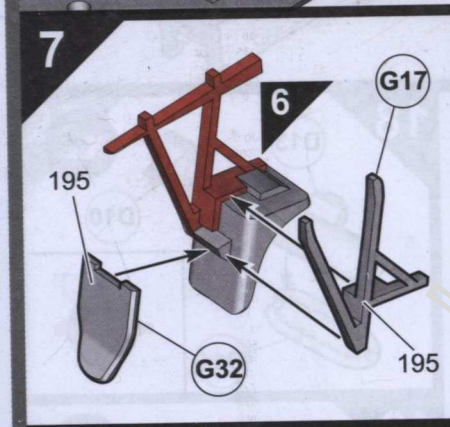
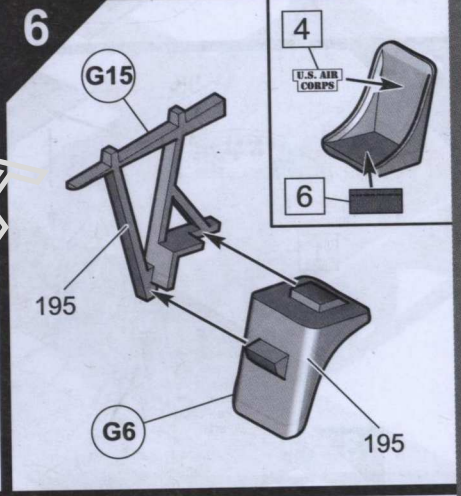
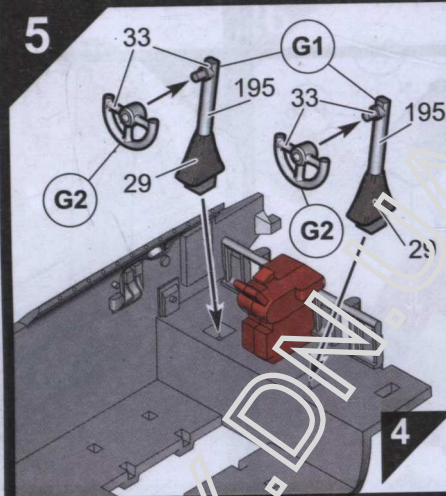
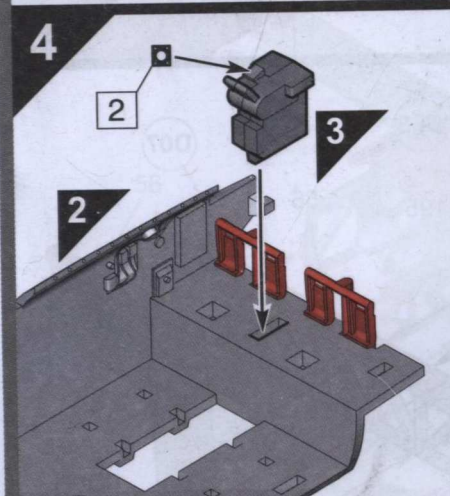
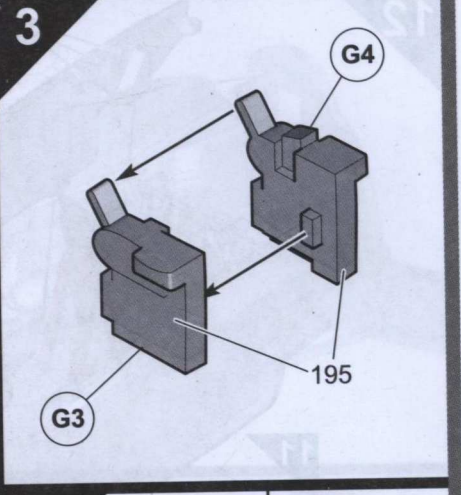
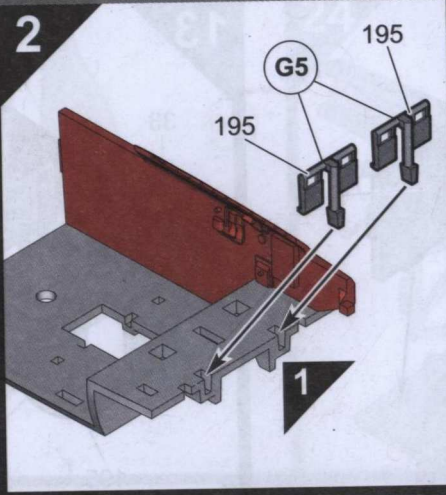
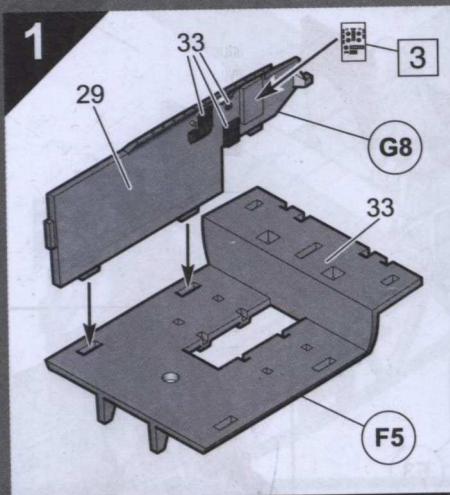

12

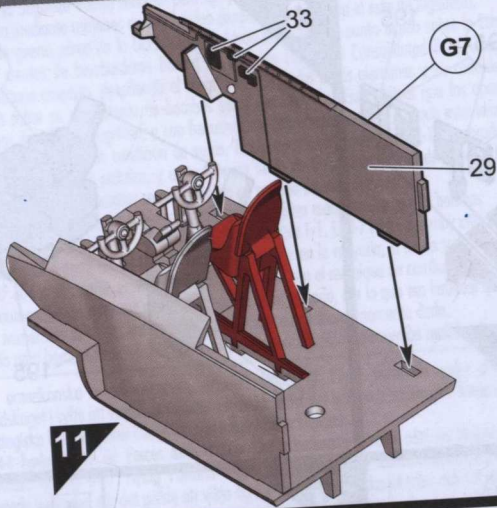

13

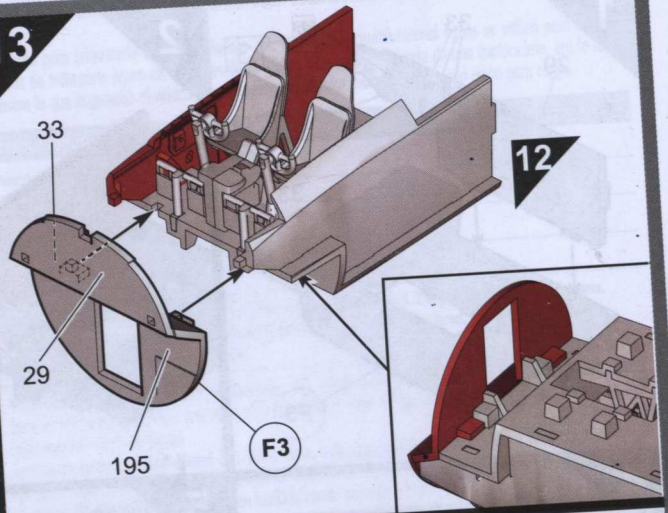

14

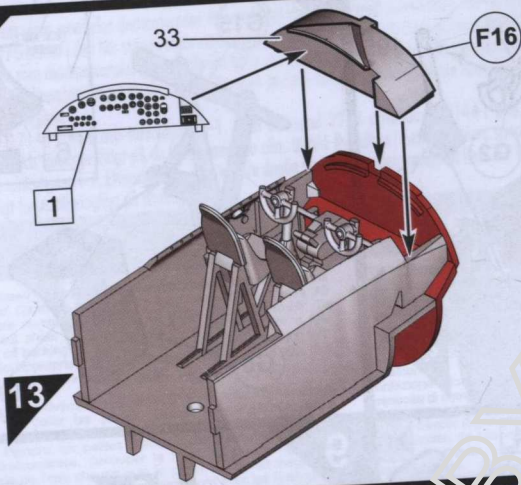

15

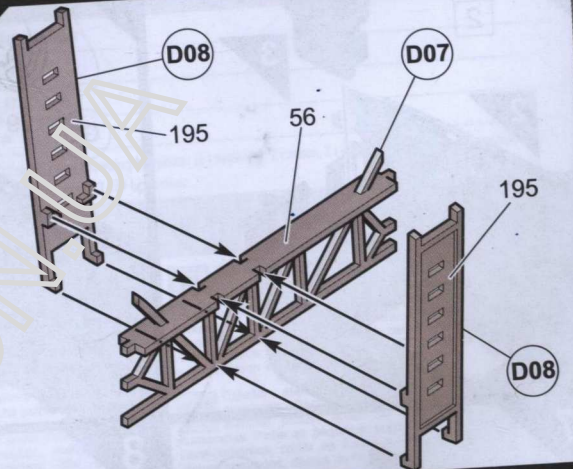

16

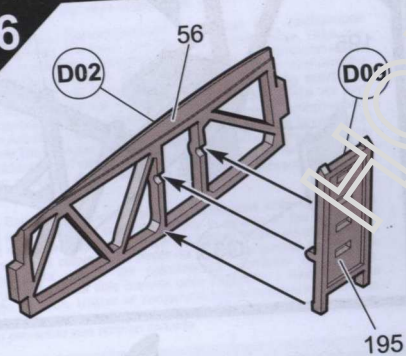

17

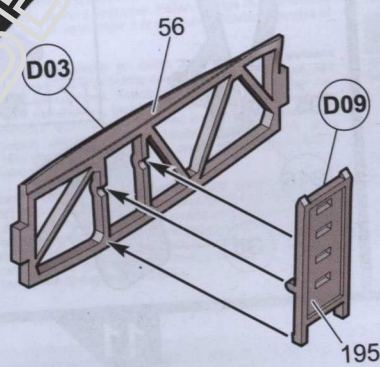

18

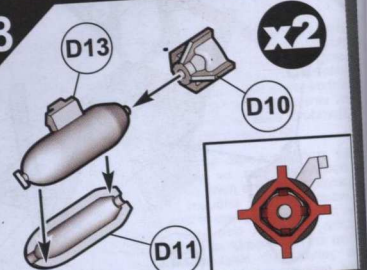

19

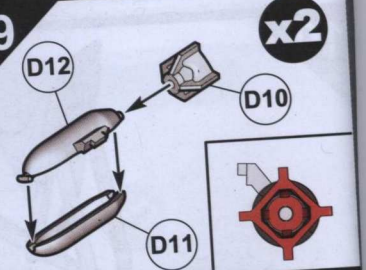

20

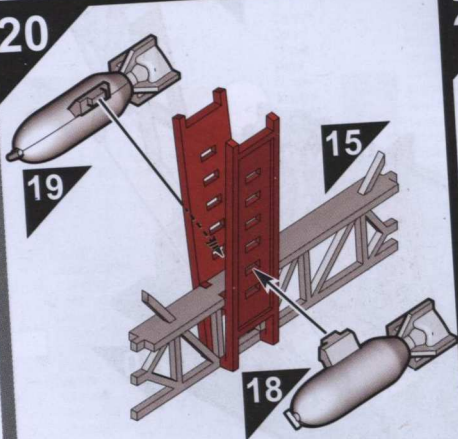

21

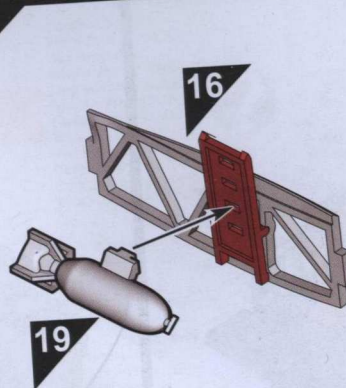

22

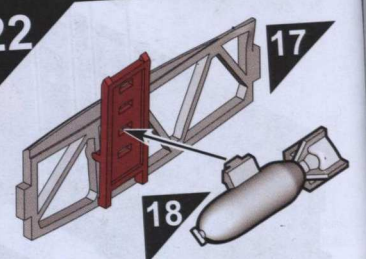

23

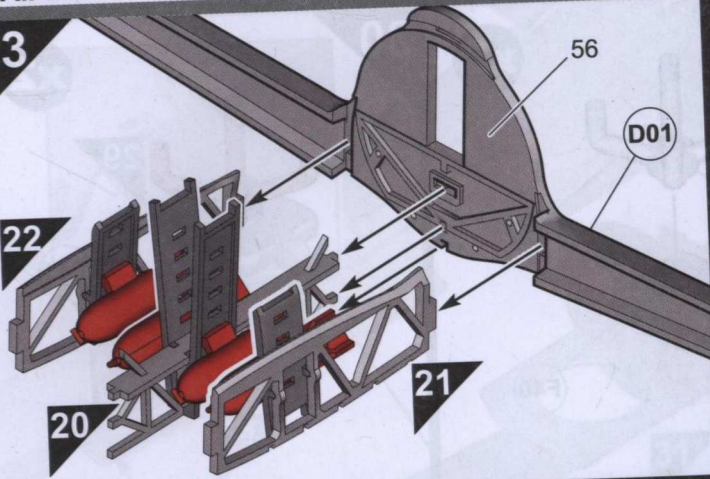

24

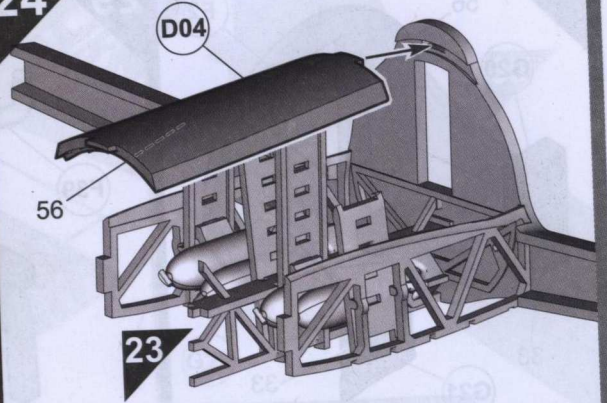

25

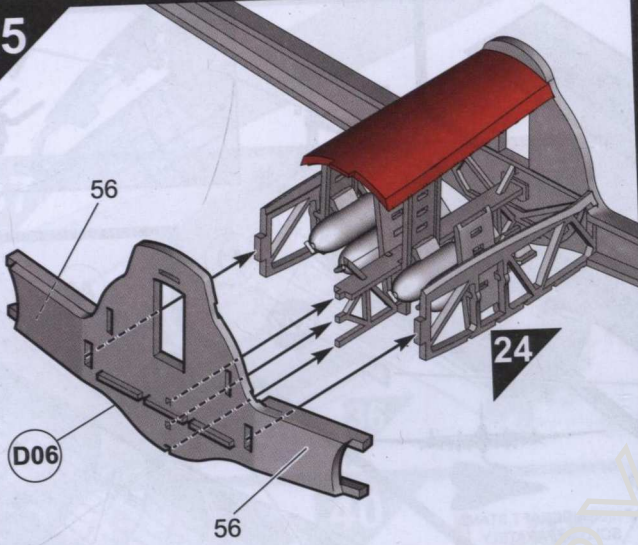

26

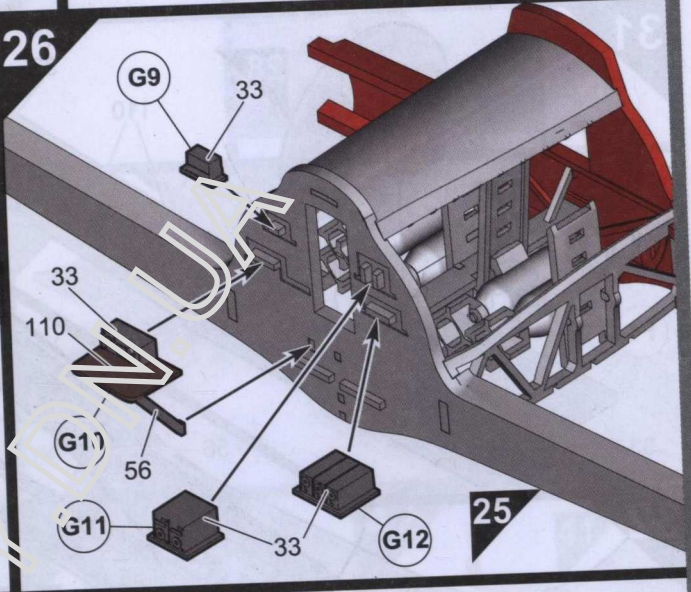

27

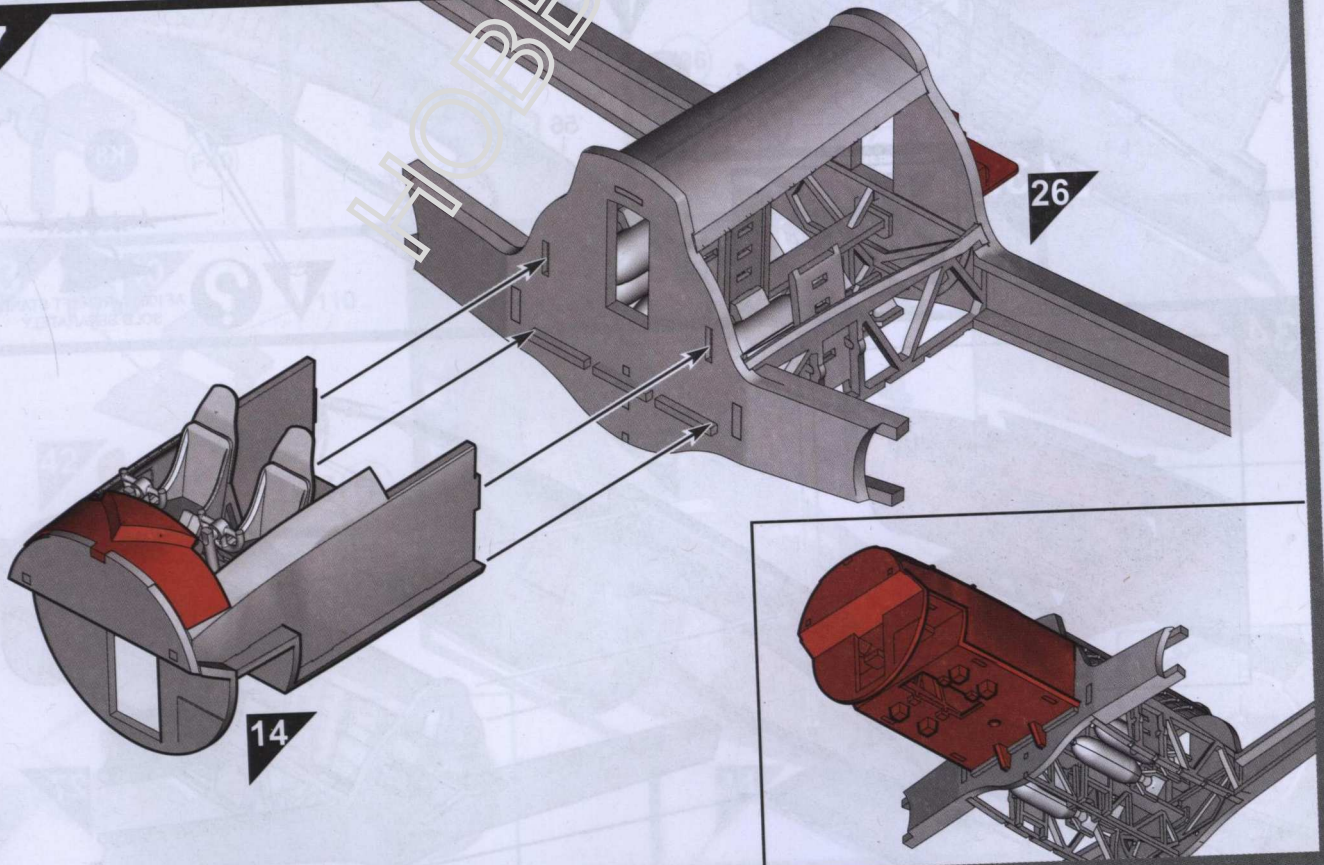

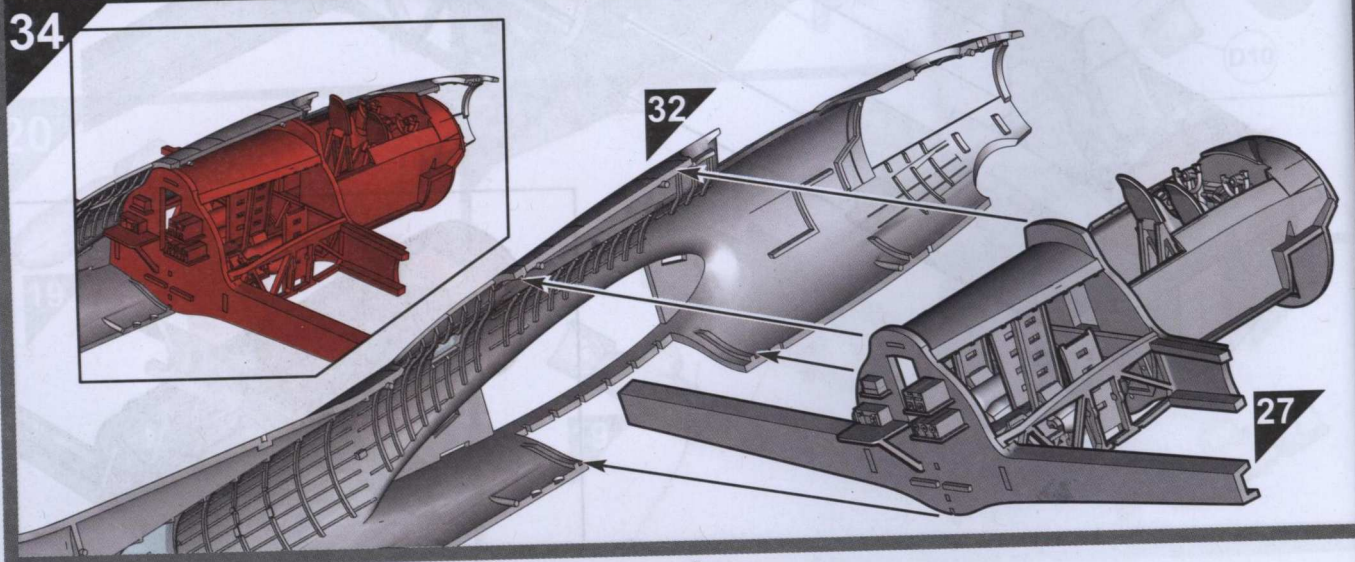
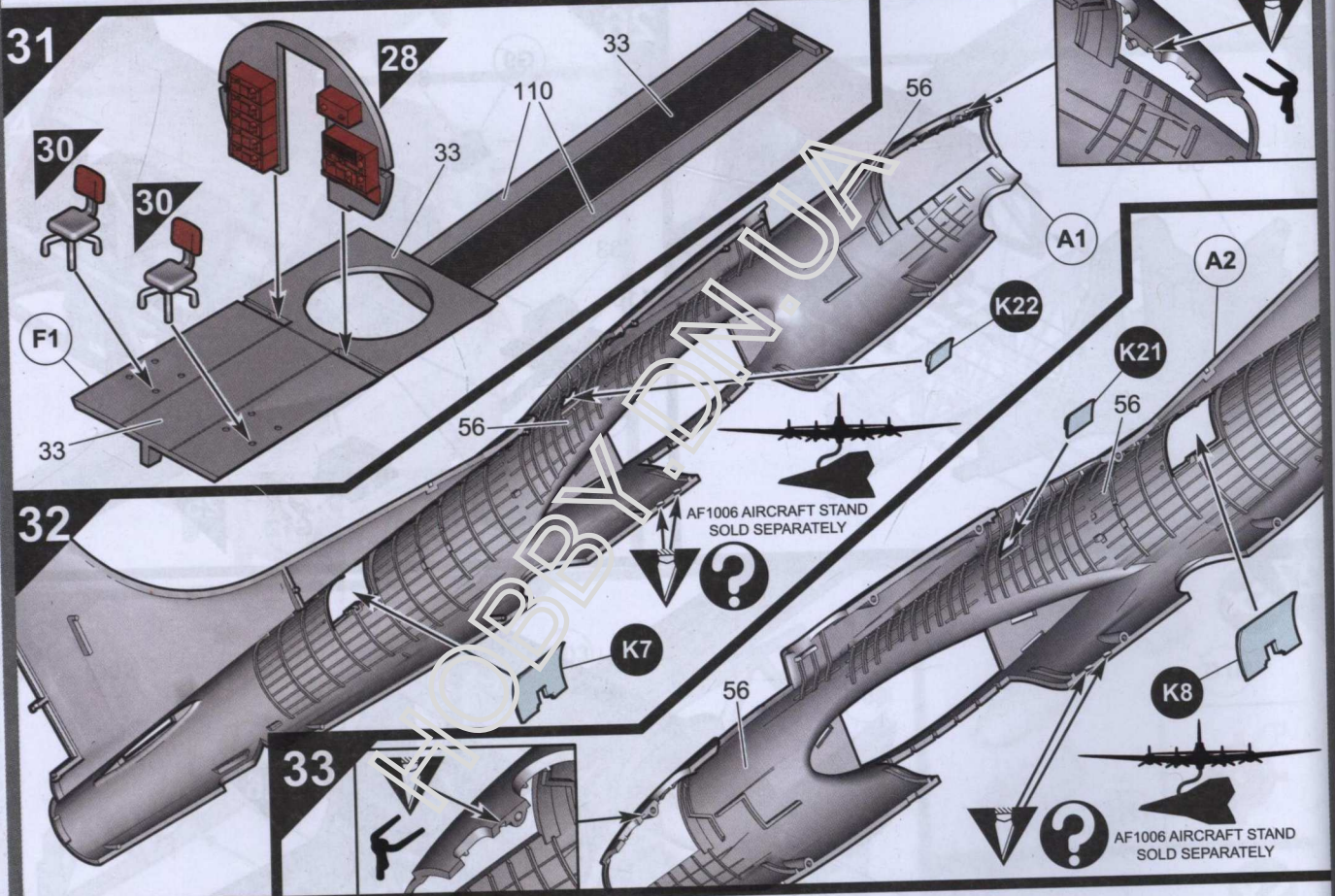
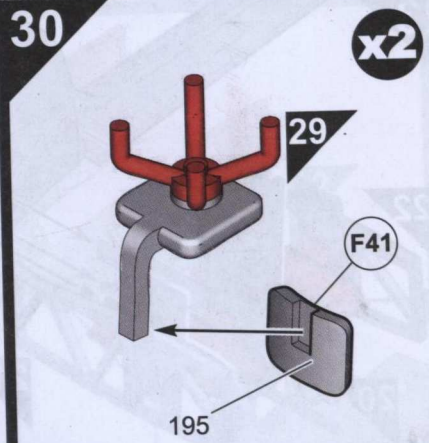
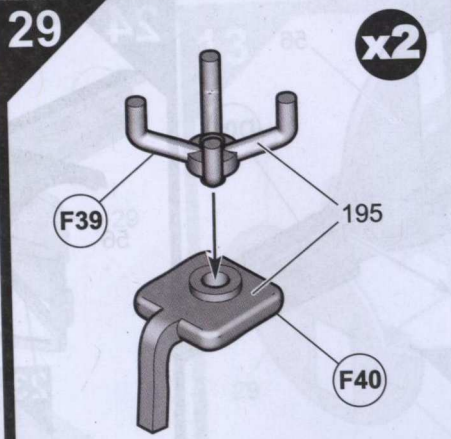
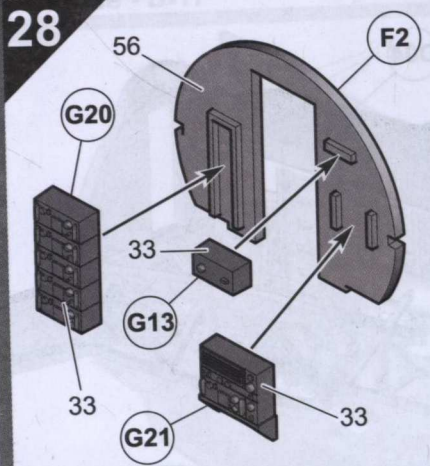

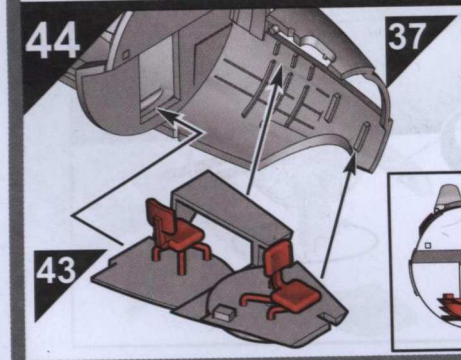
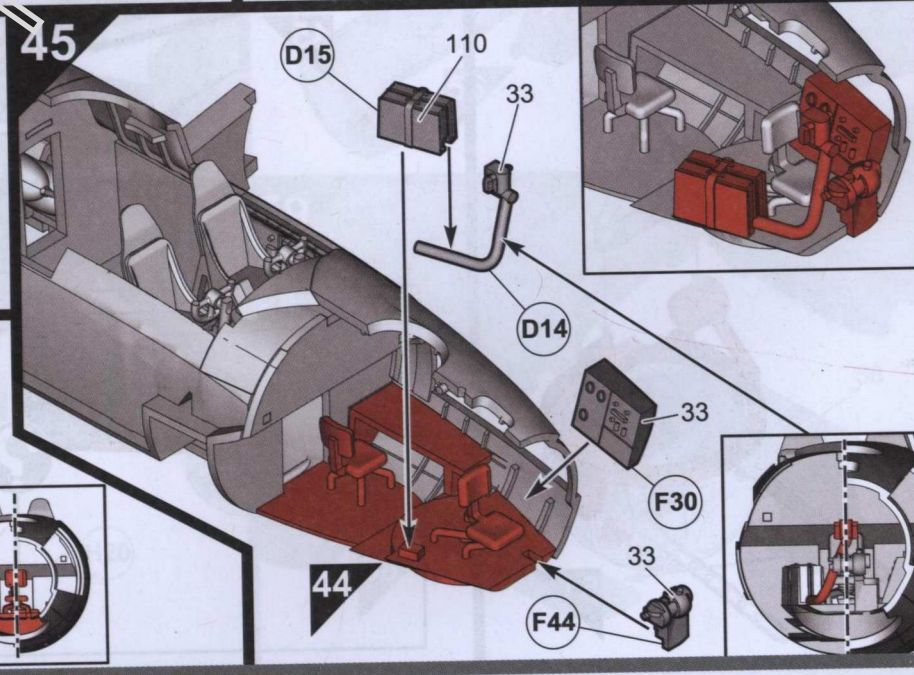
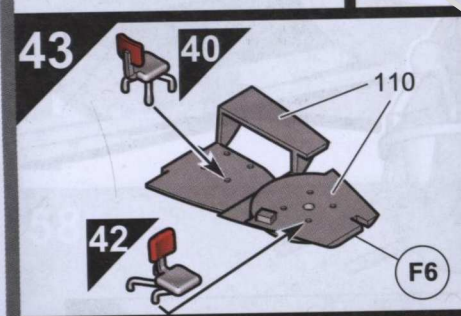
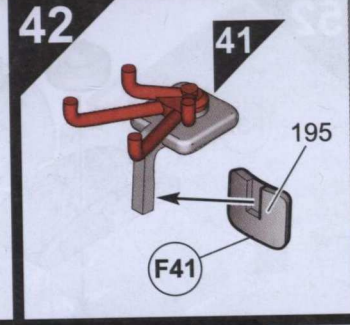
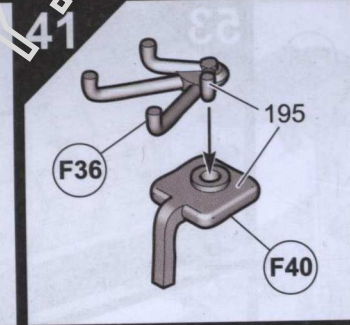
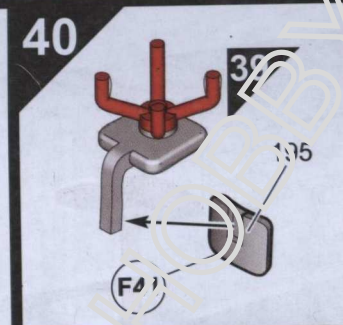
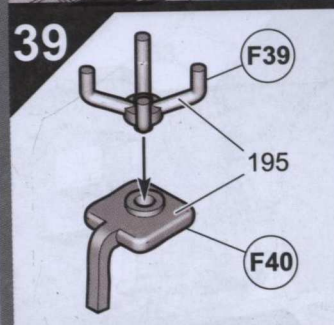
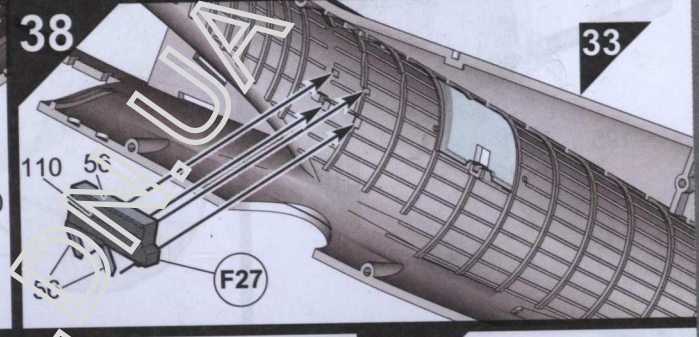
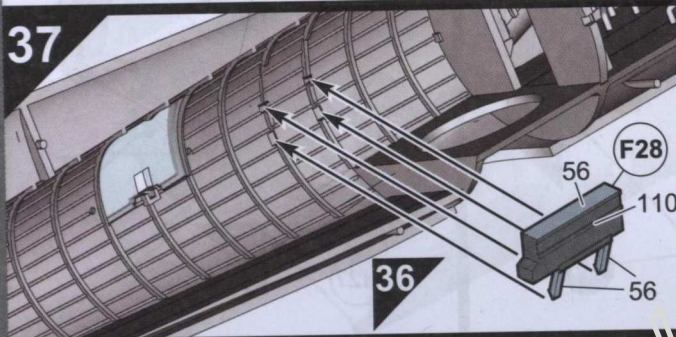
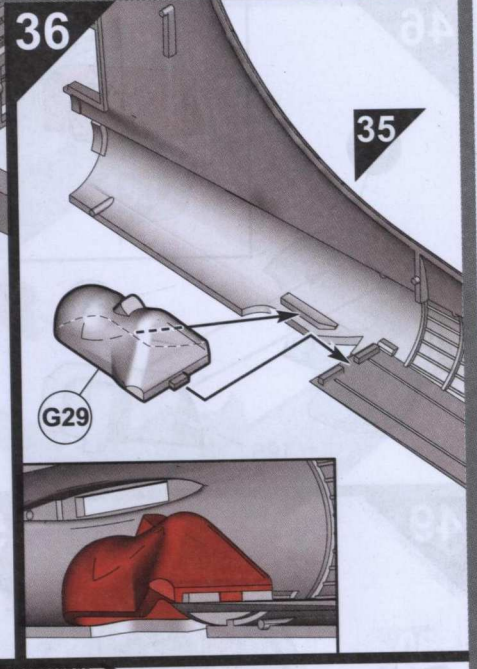
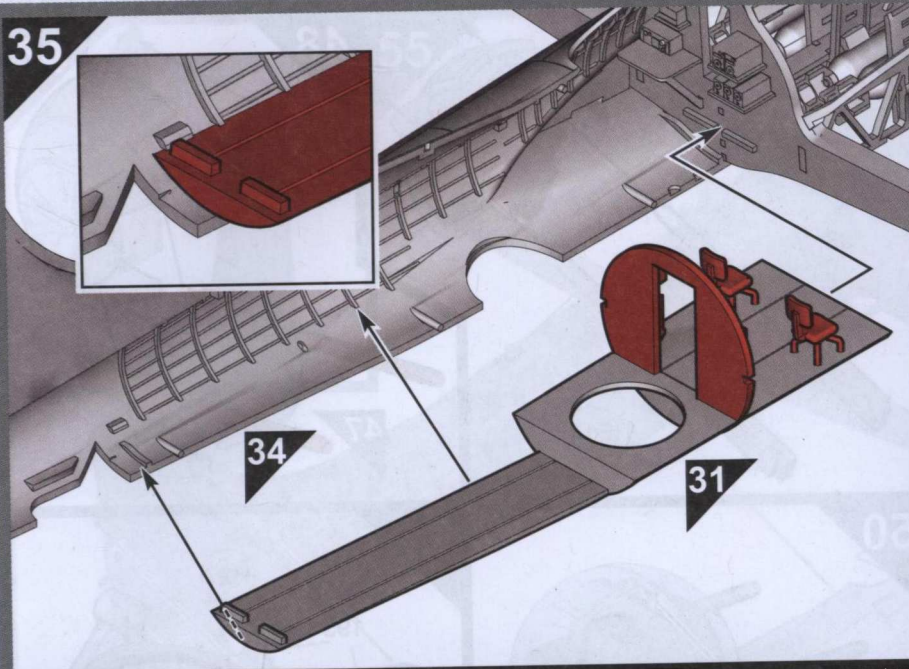

46

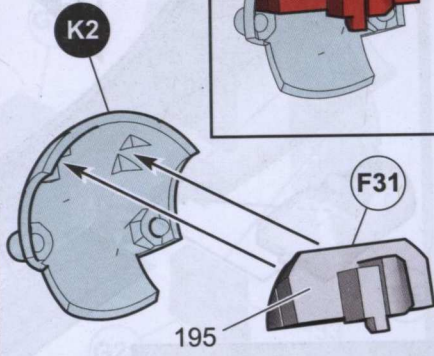

47

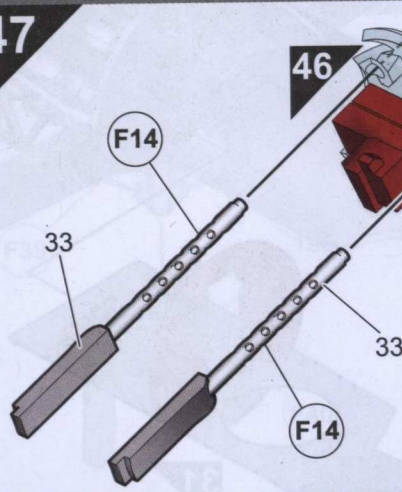

48

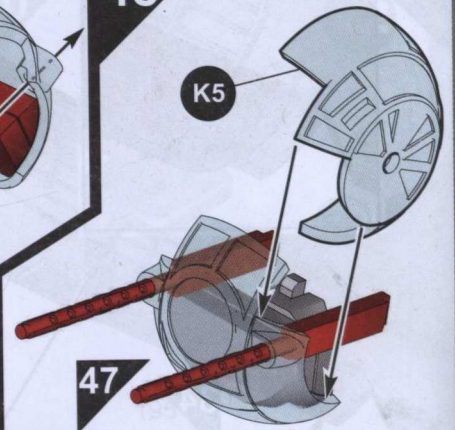

49

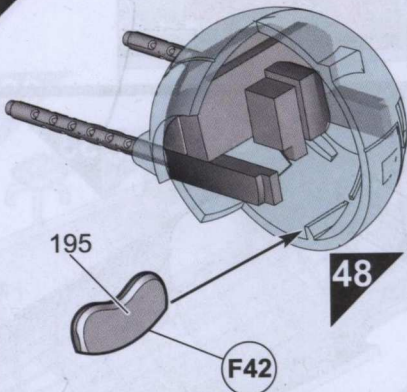

50

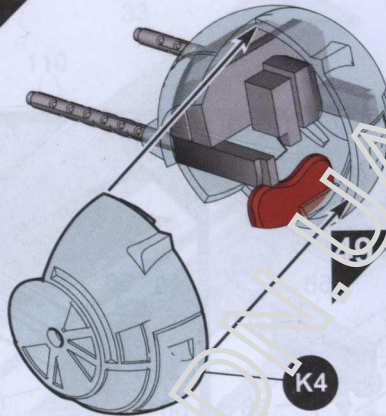

51

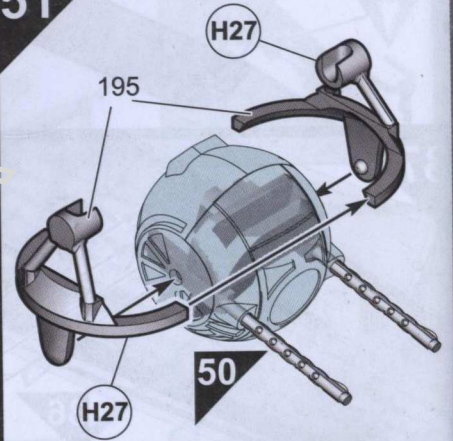

52

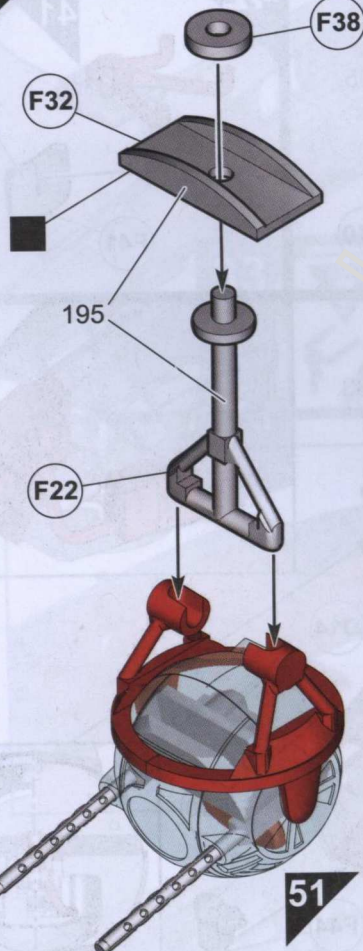

53

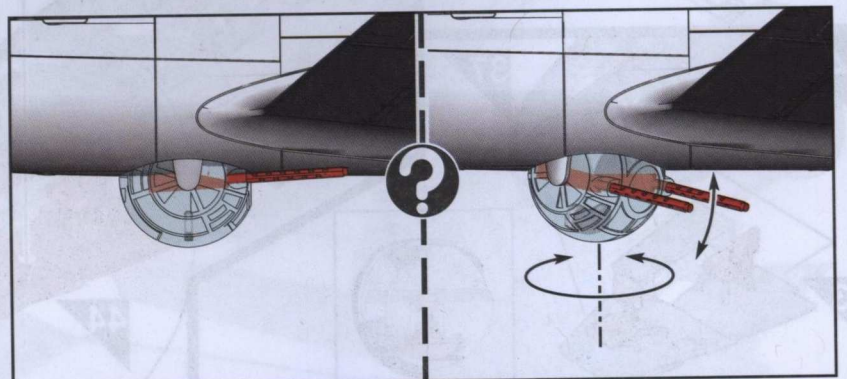
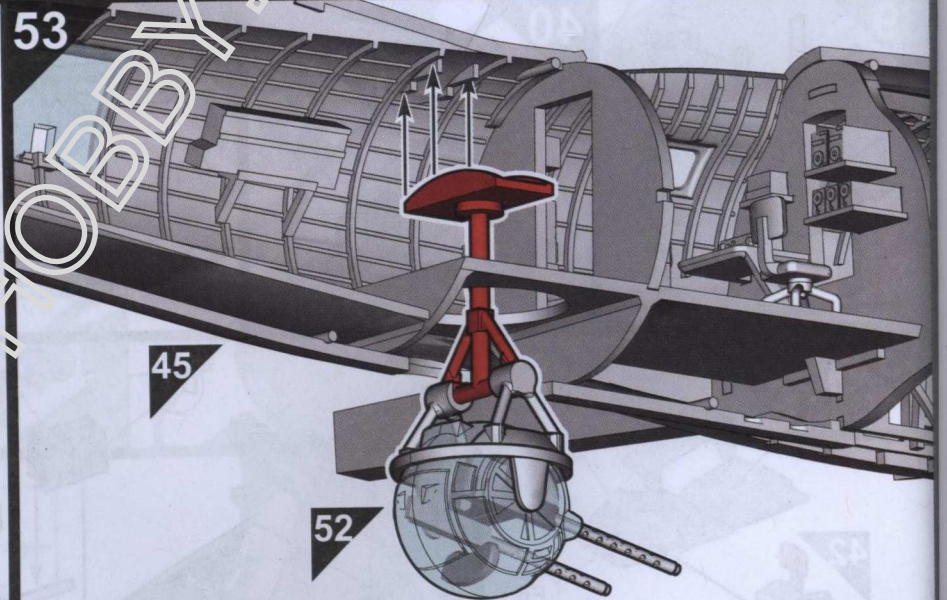

54

B04

55

08

B03

53

54

58

22°

22°

56

33

57

C02

56

H17

H16

56

56

58

59

56

H20

57

56

H13

58

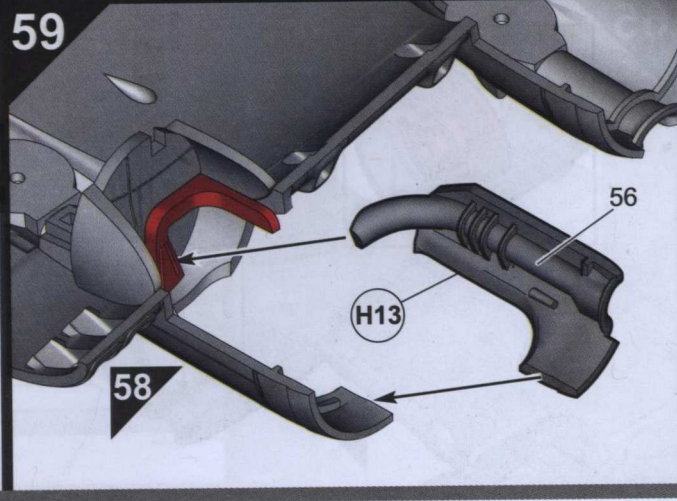
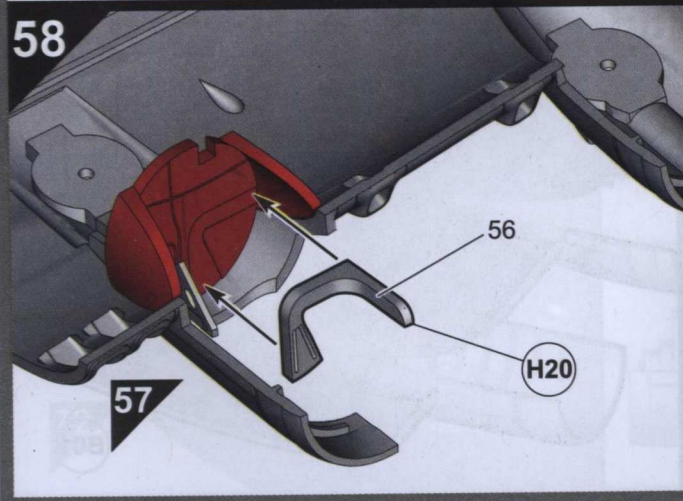
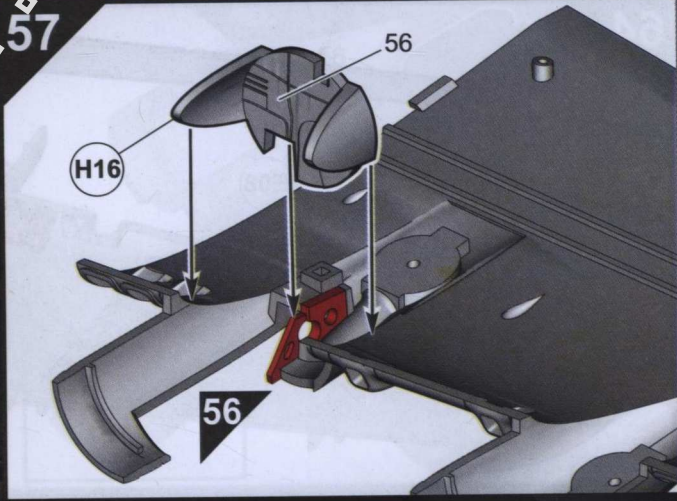
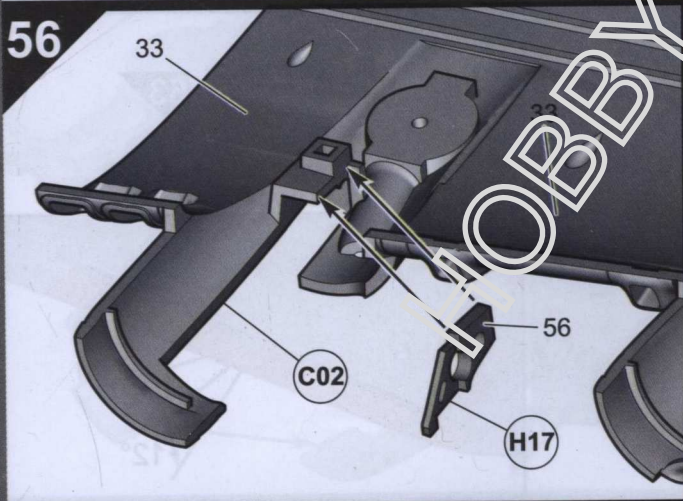
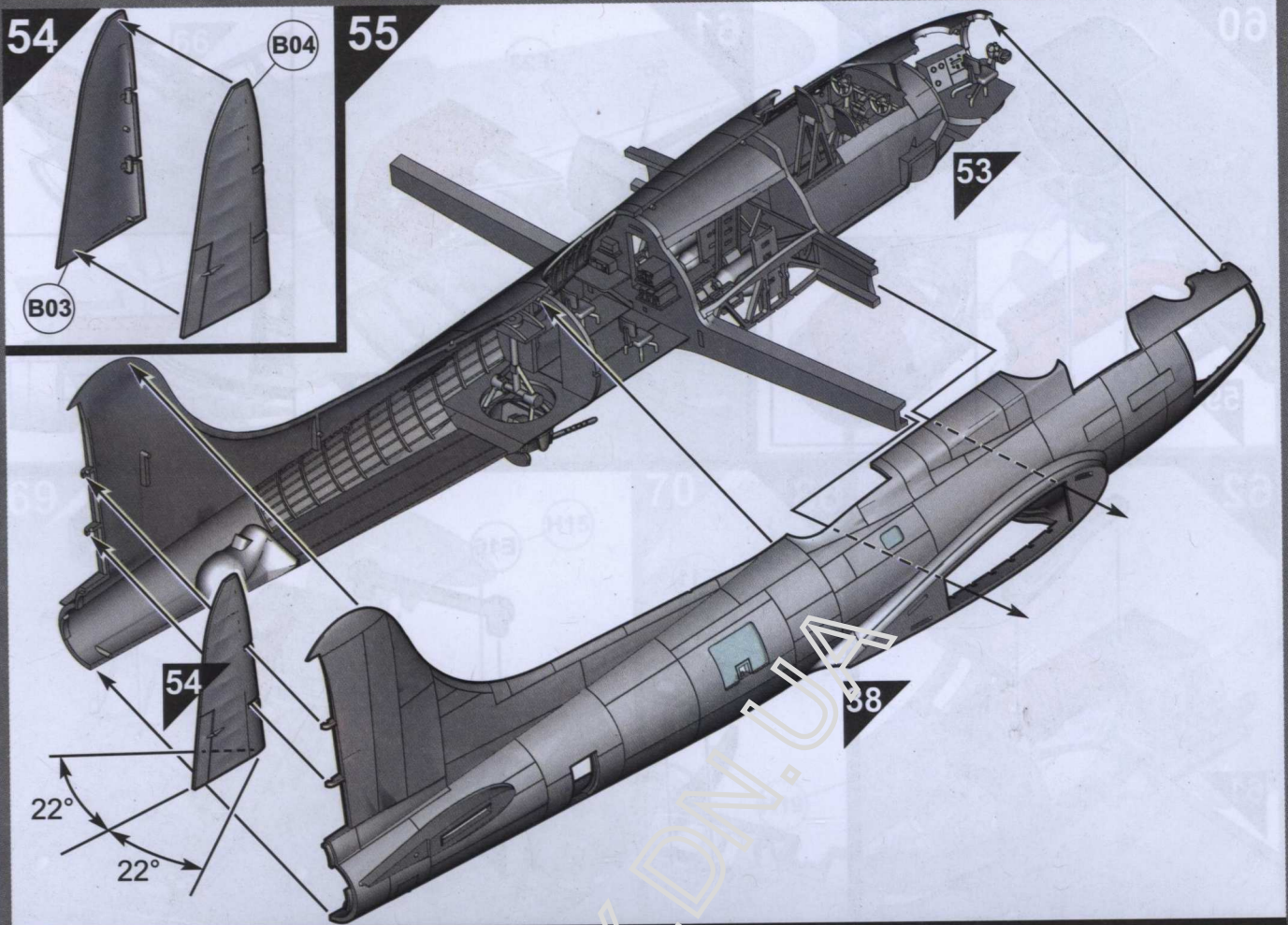



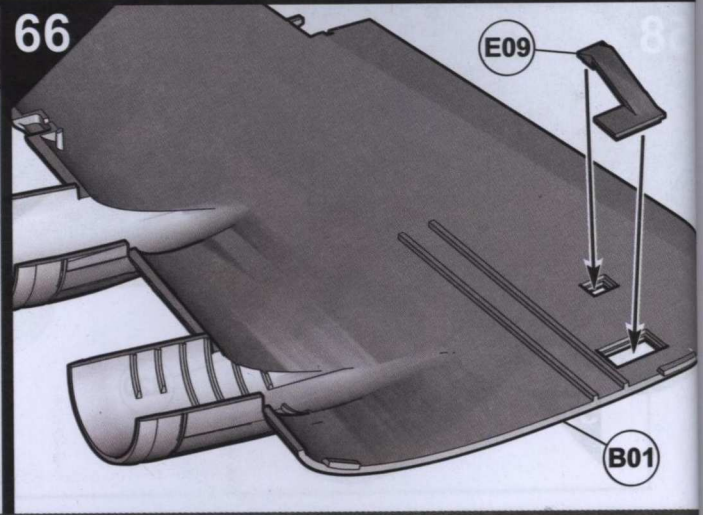
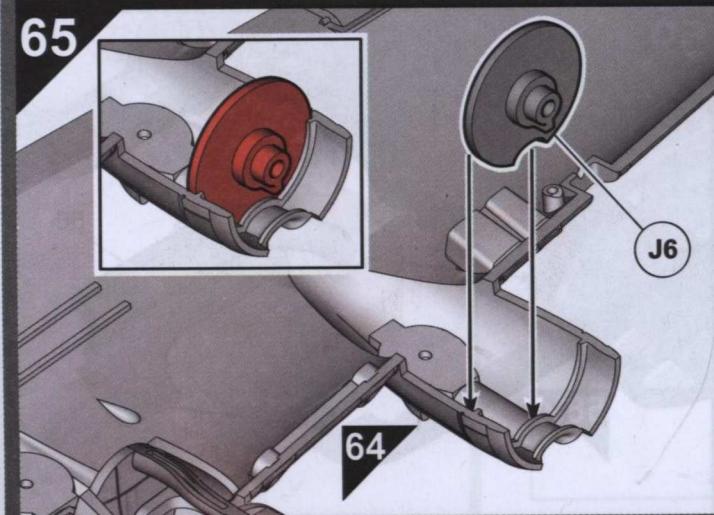
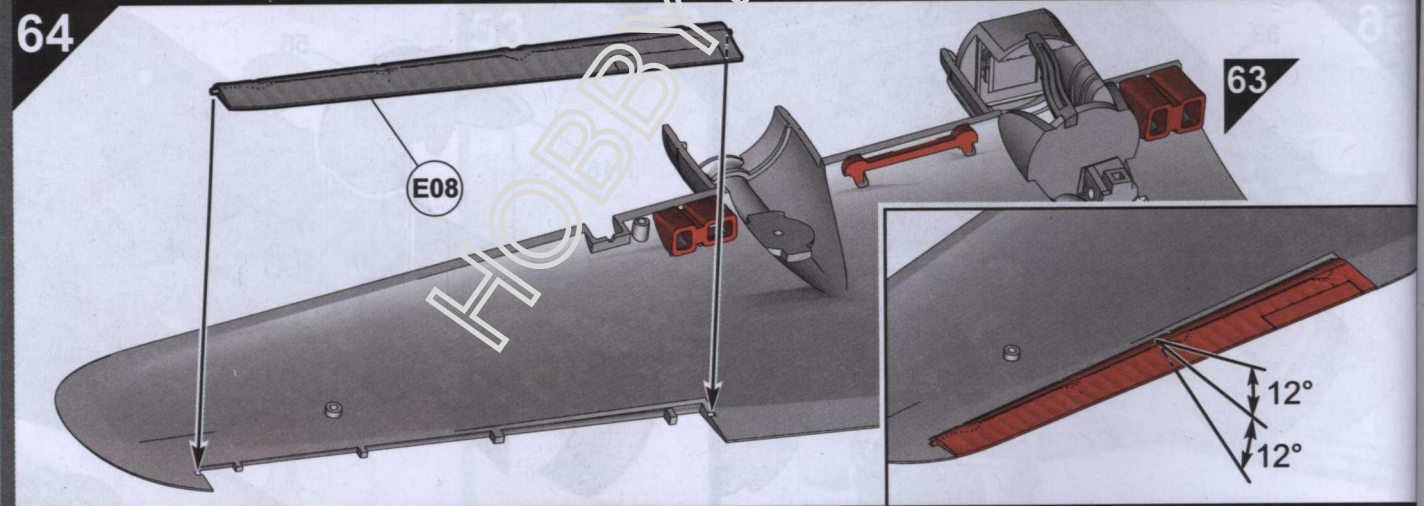
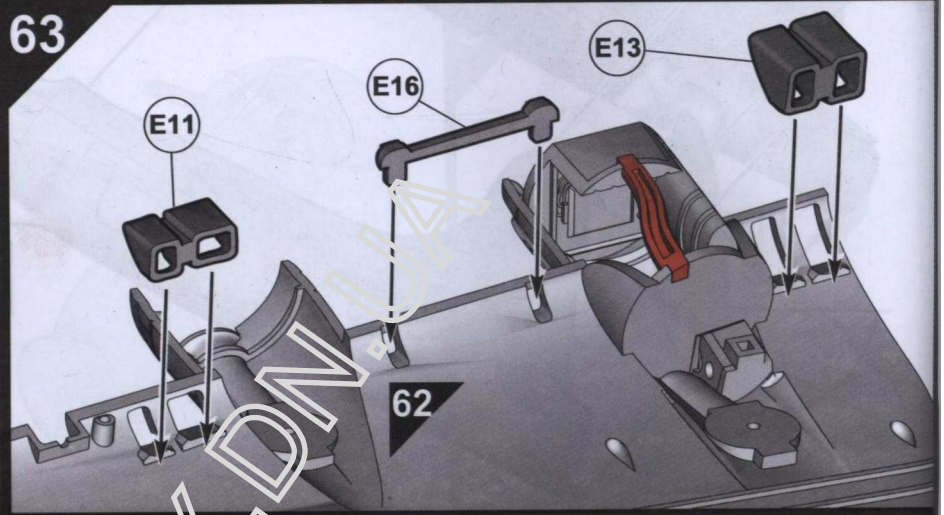
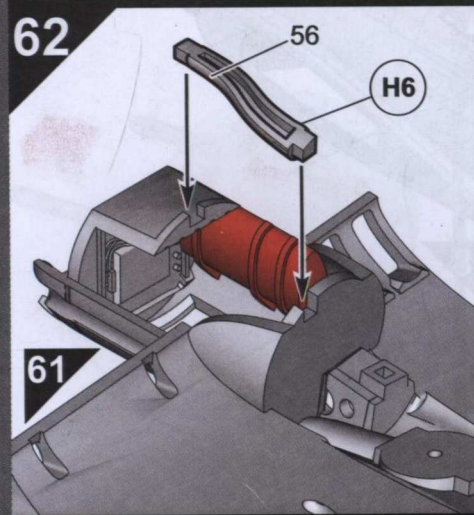
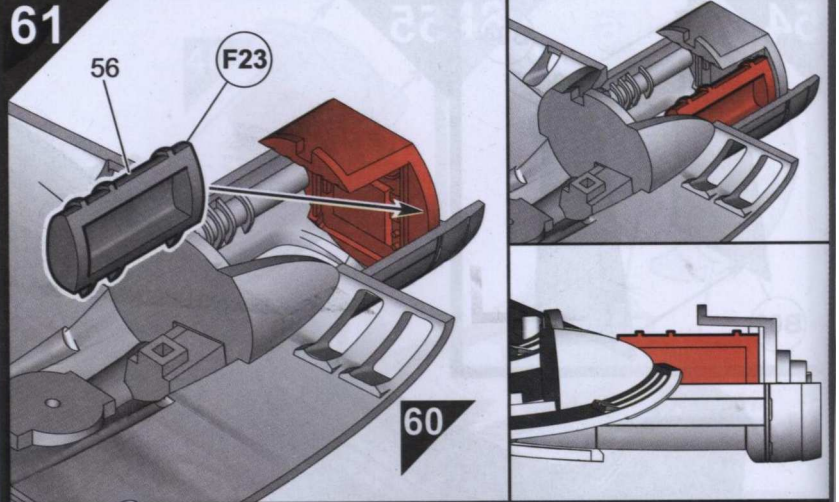
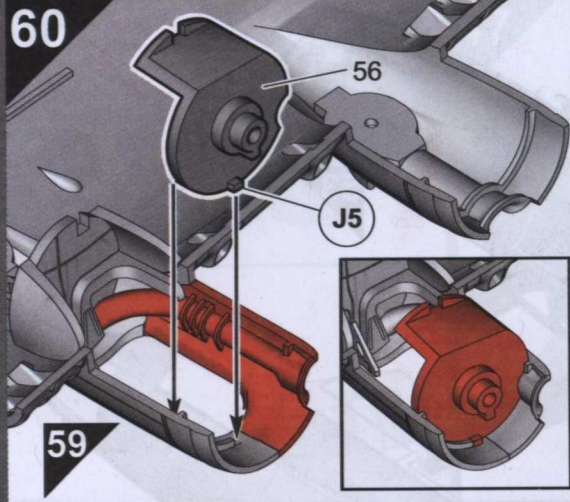

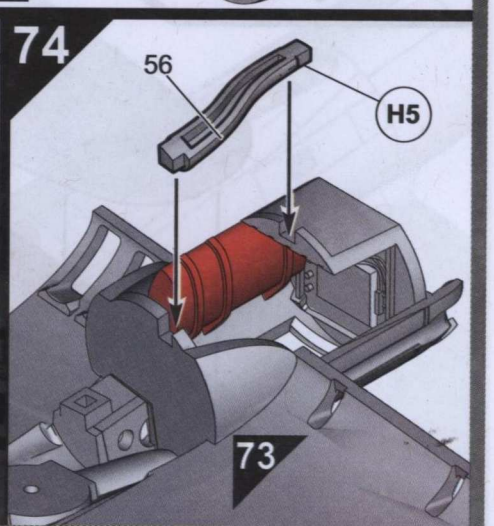
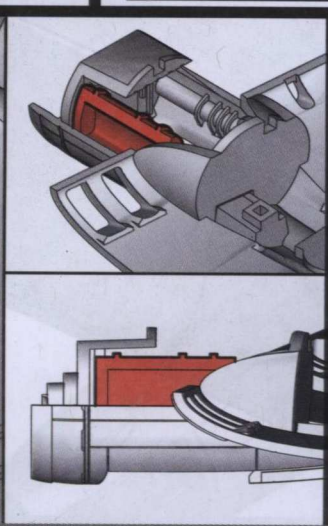
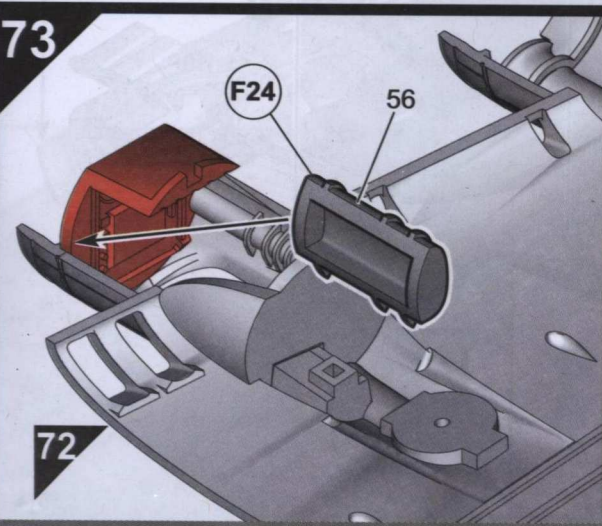
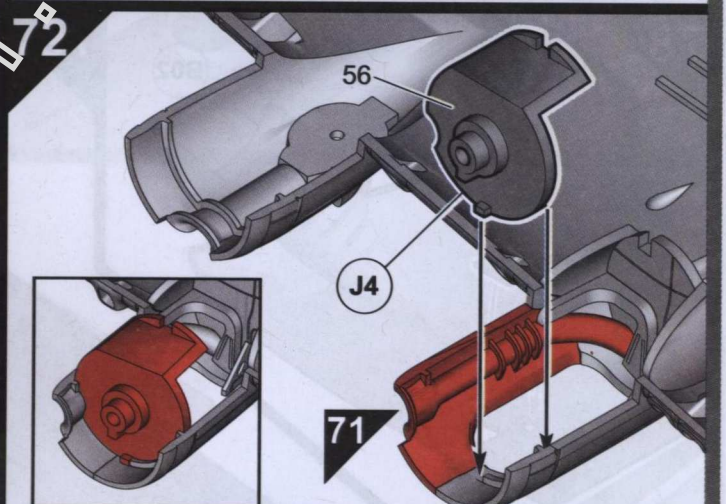
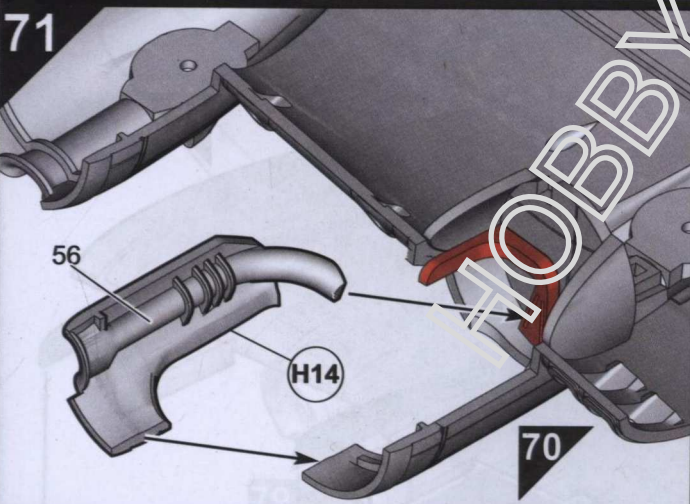
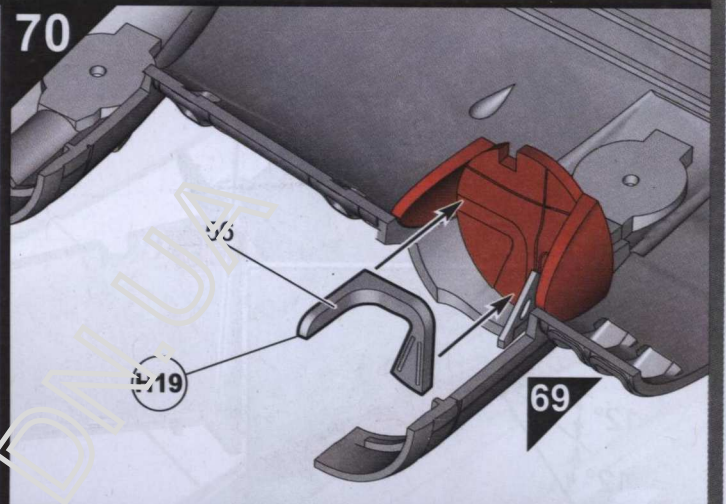
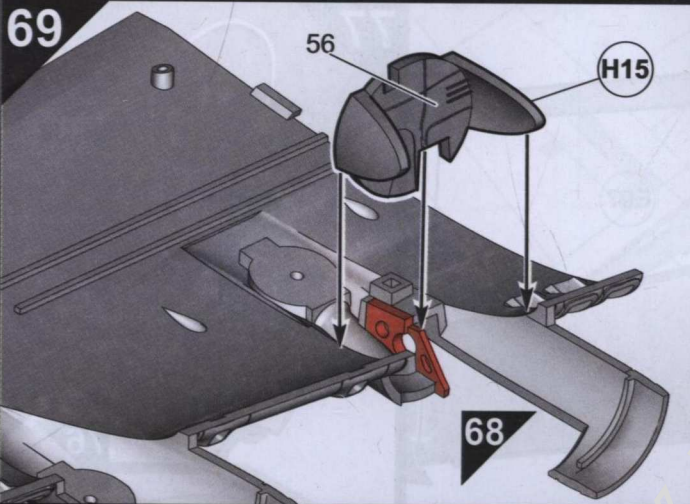
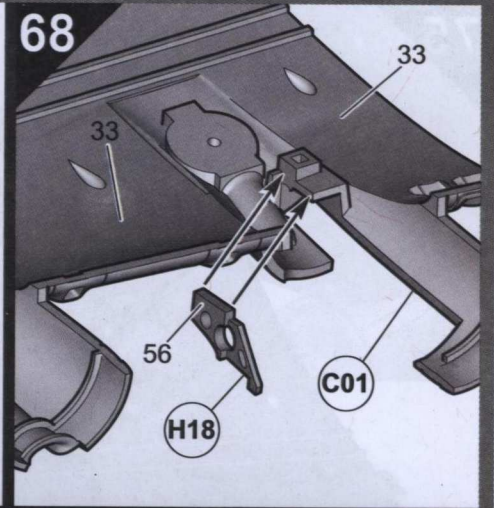
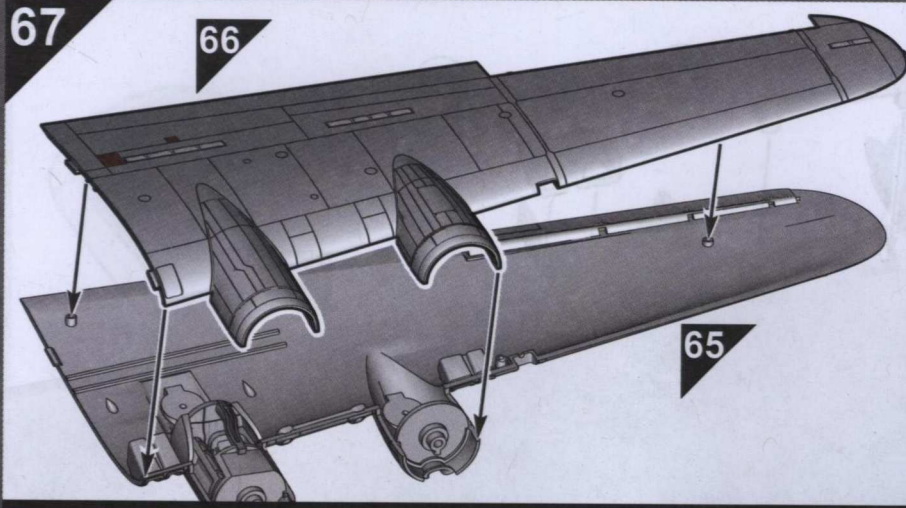

75

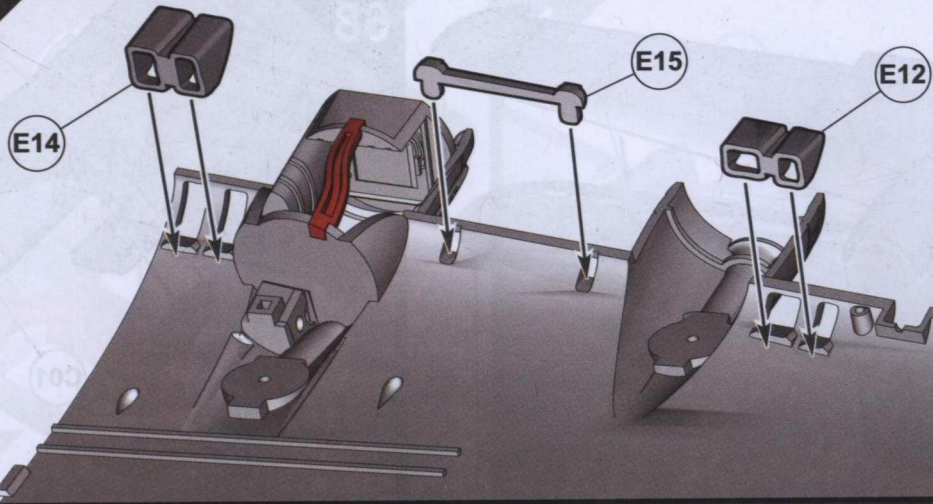

76

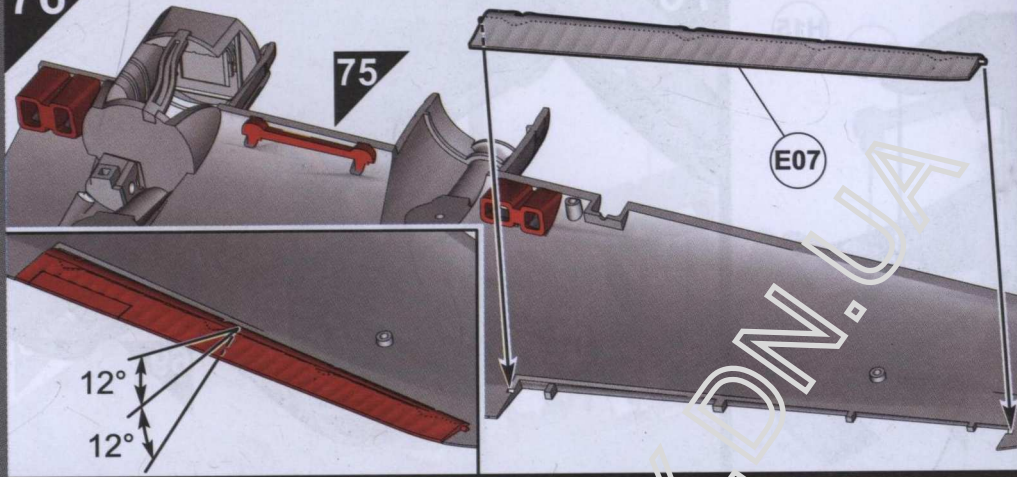

77

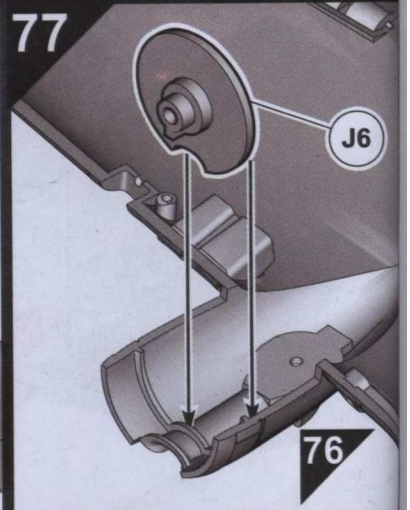

78

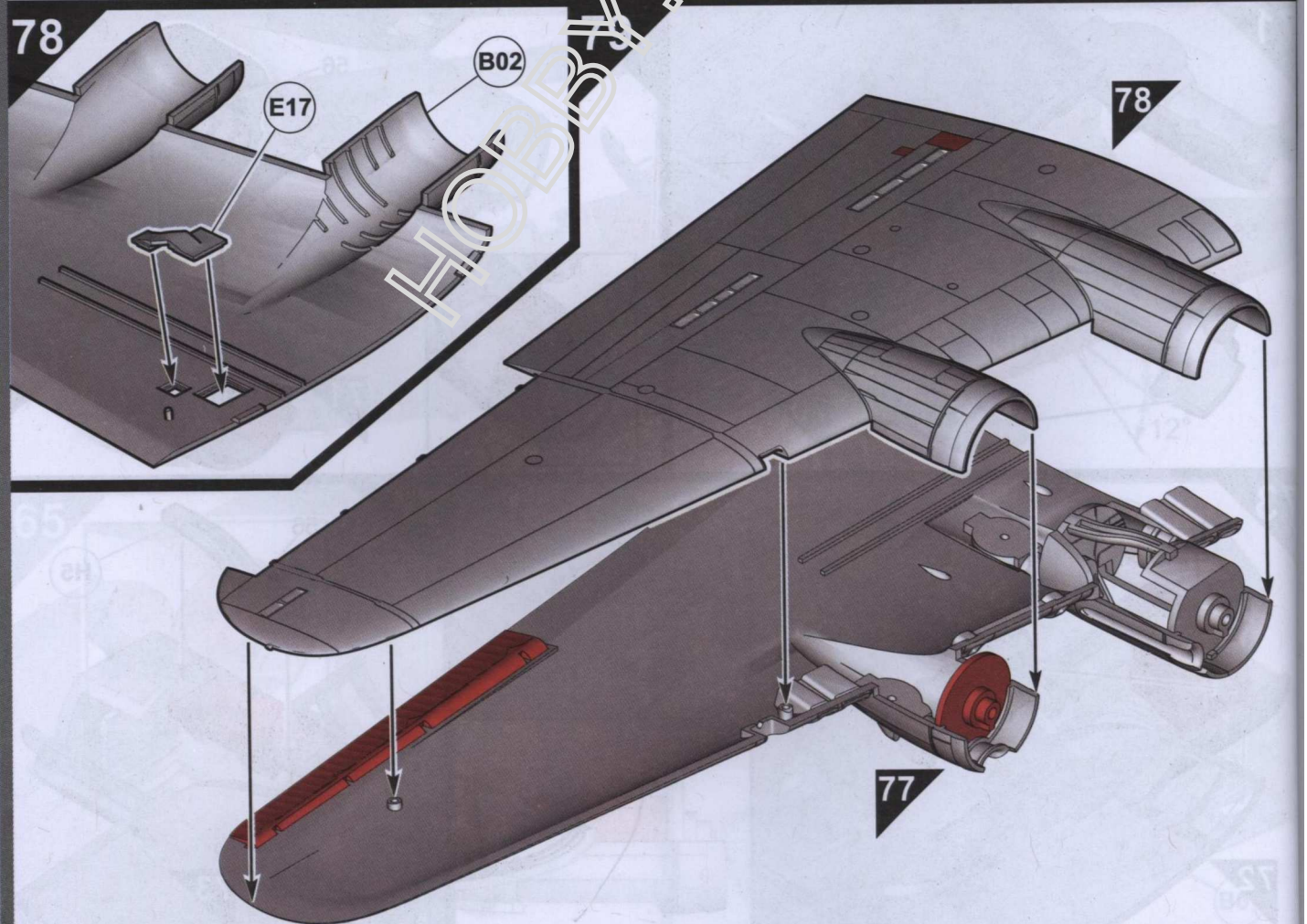

80

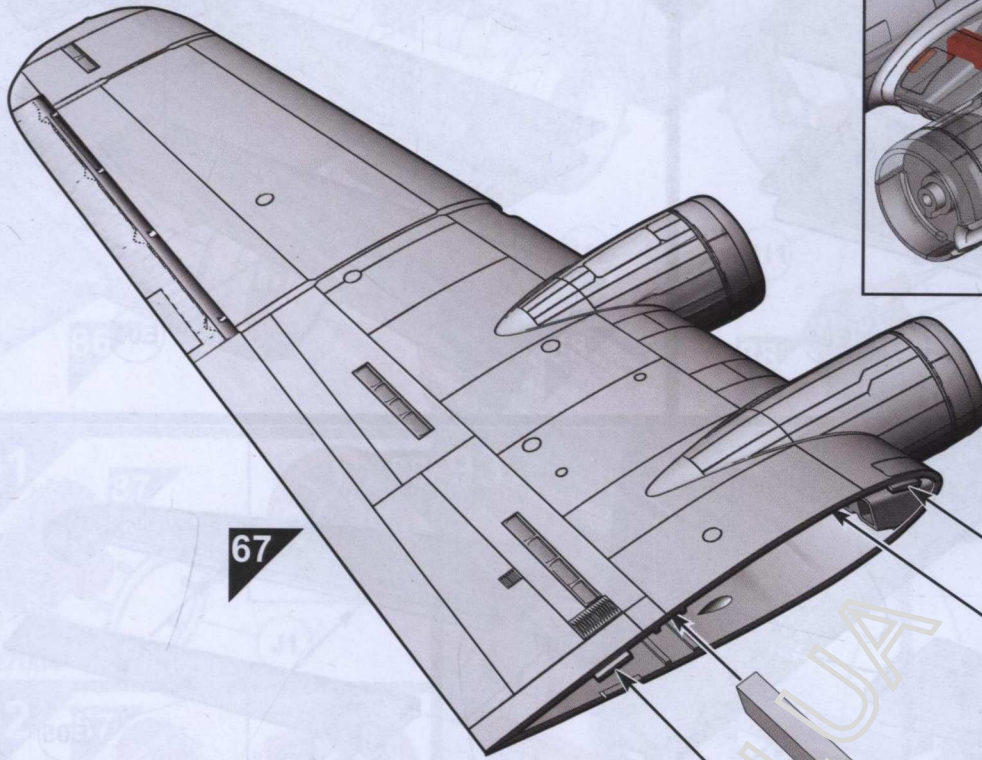
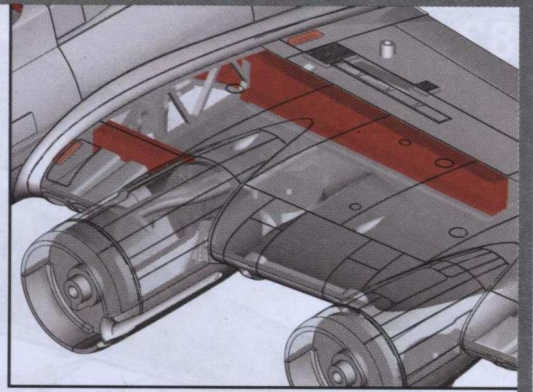

81

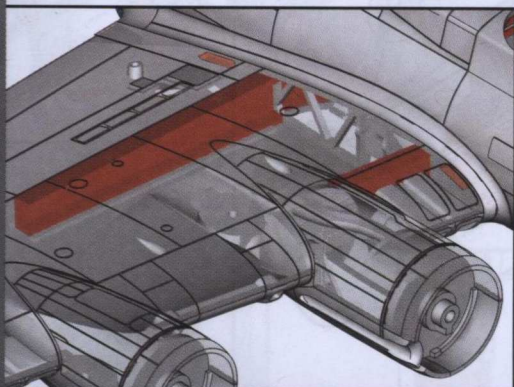
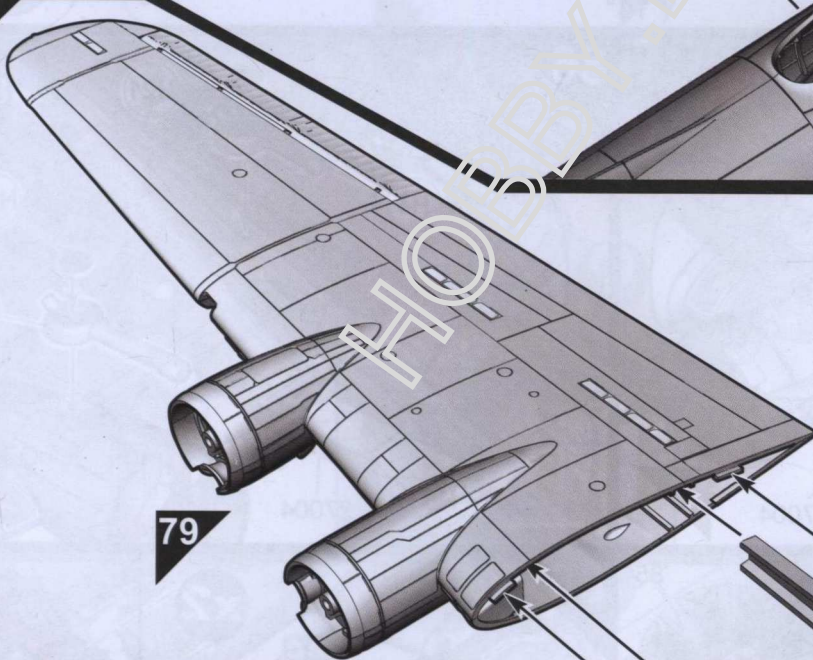

82

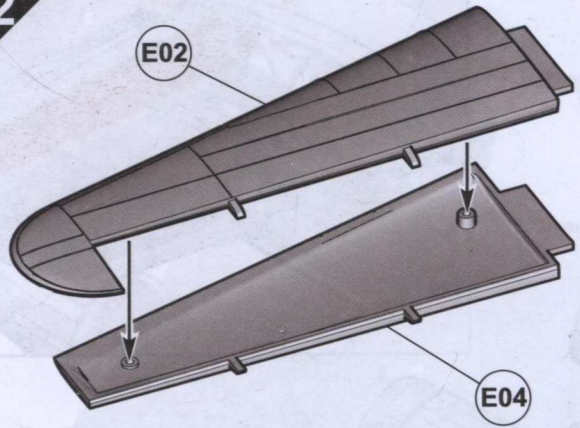

83

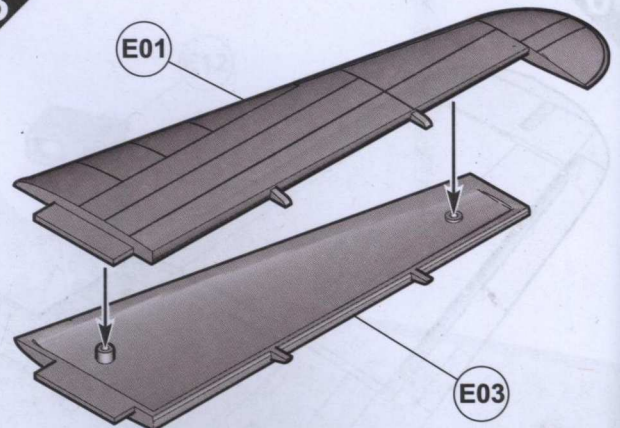

84

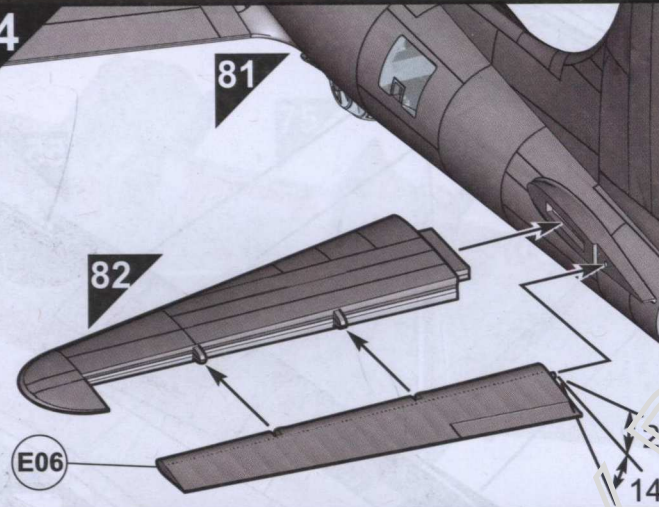

83

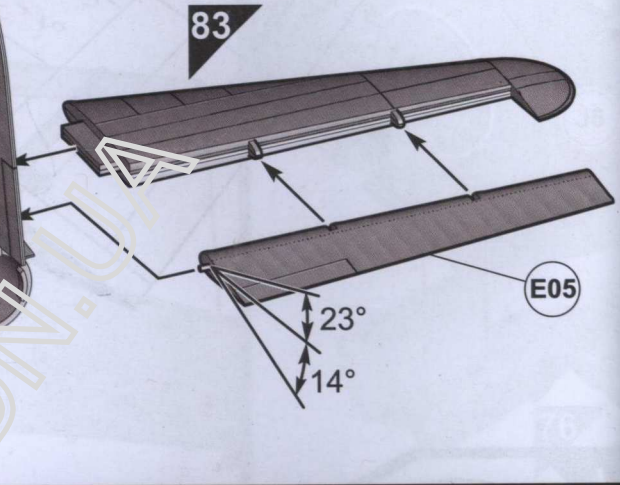

85

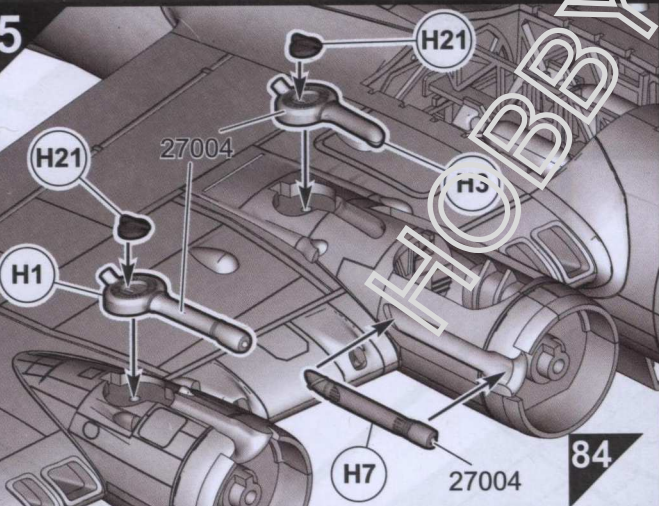

86

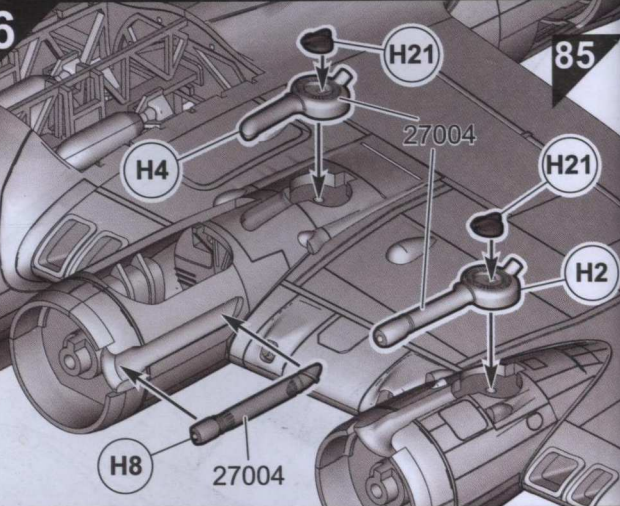

87

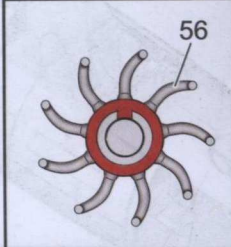
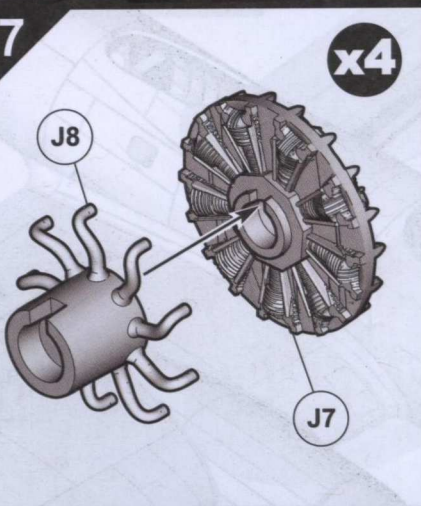

88

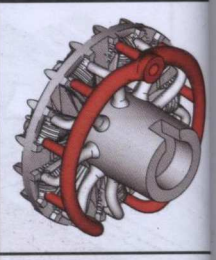
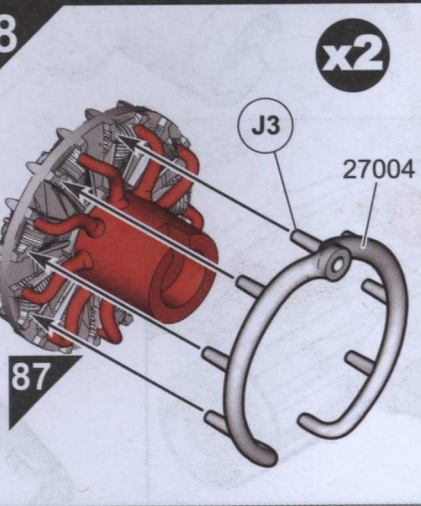

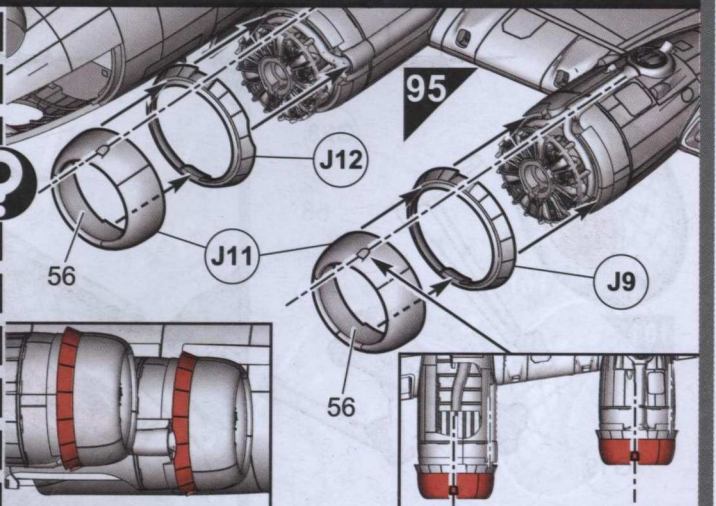
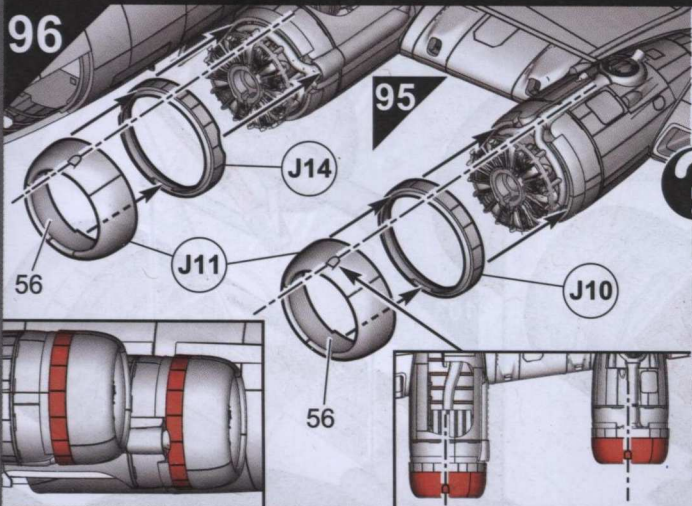
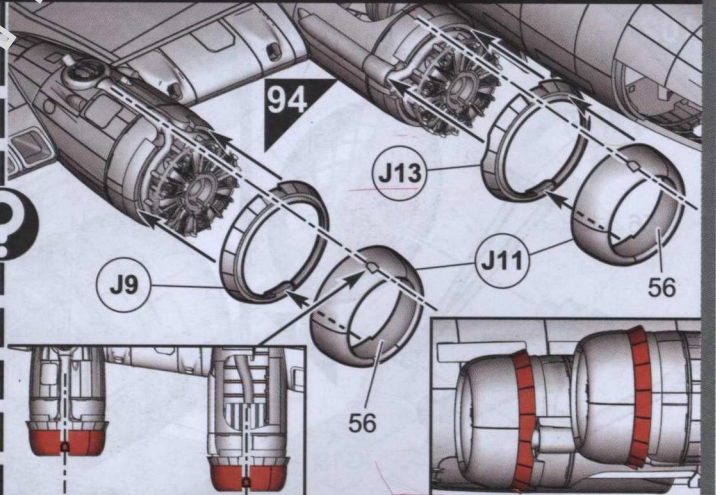
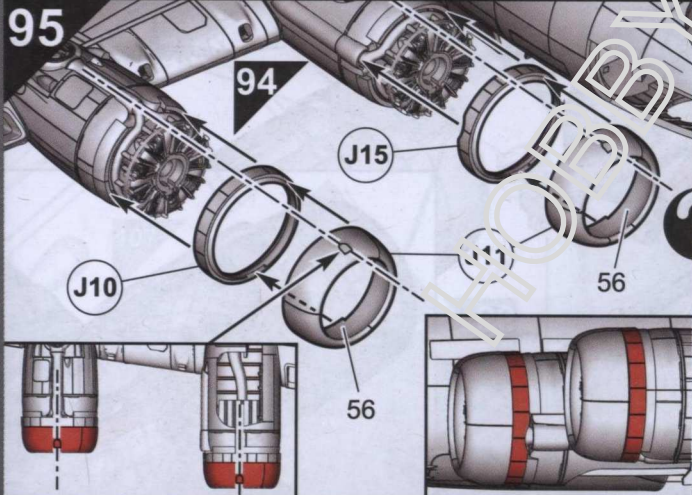
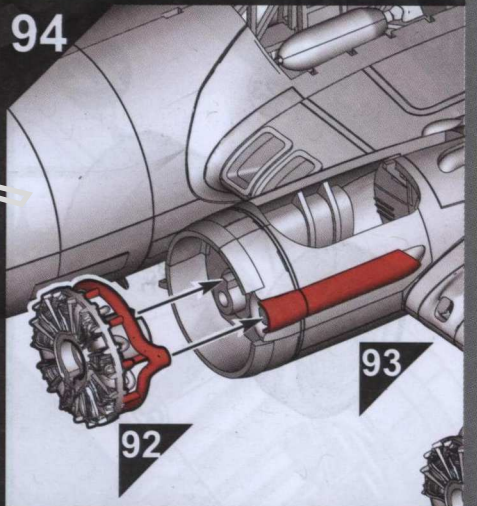
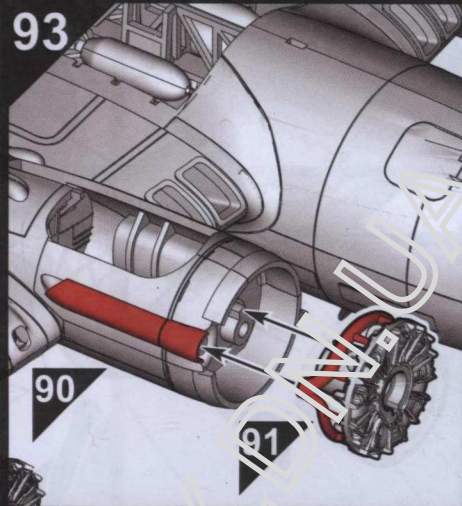
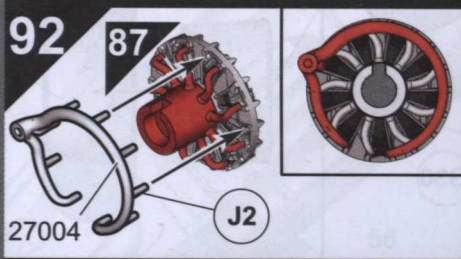
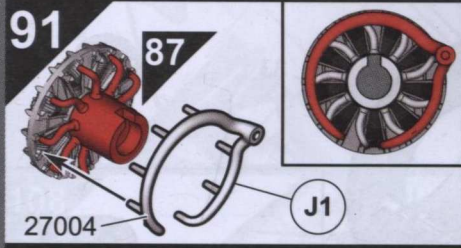
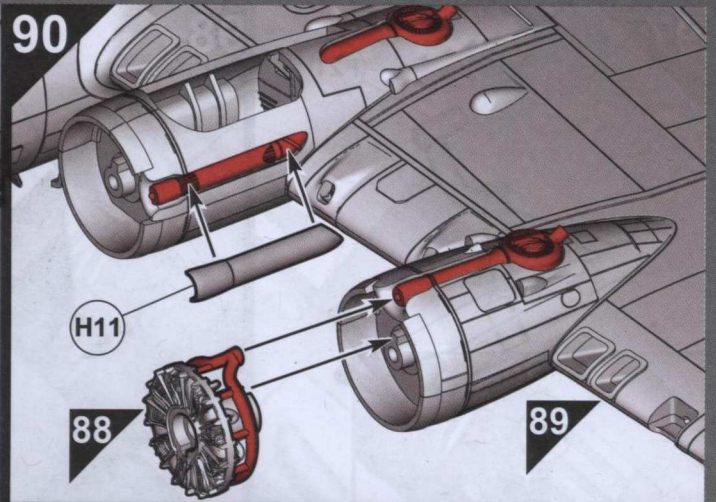
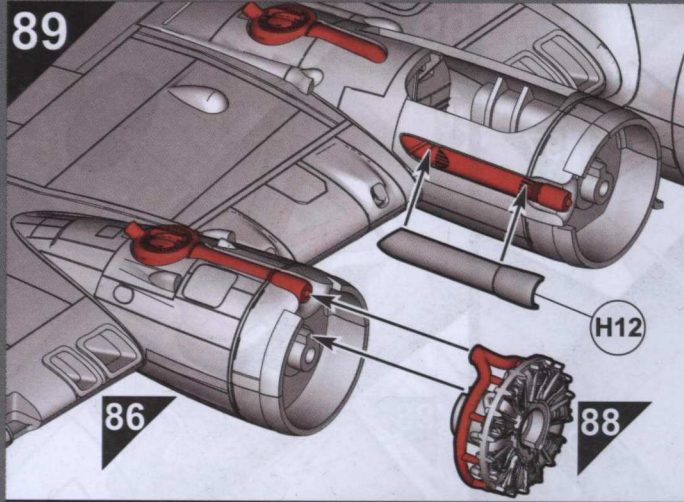

97

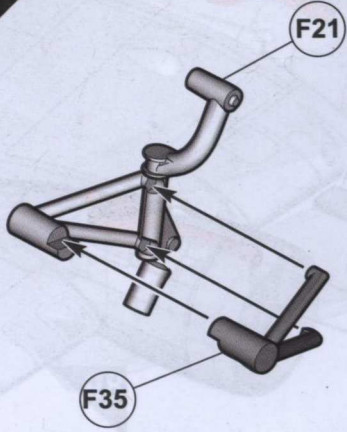

98

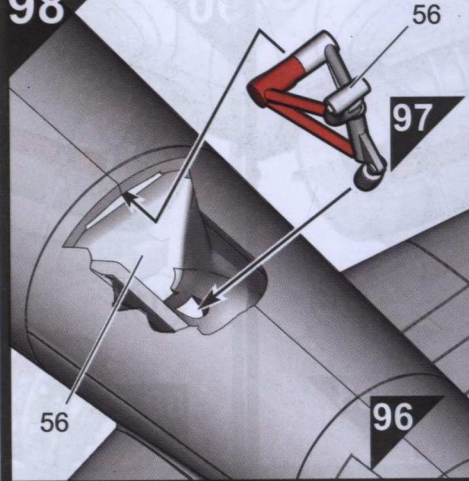

99

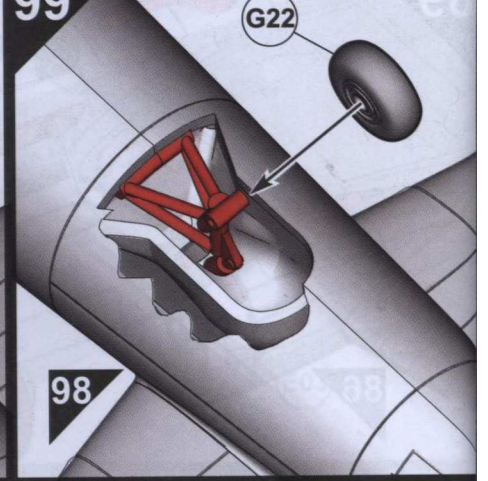

100

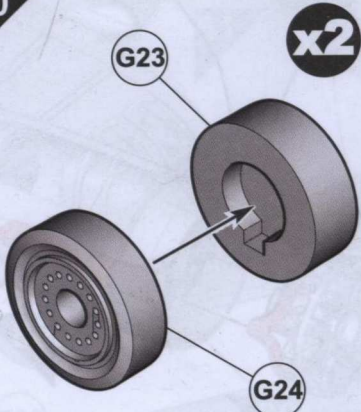

101

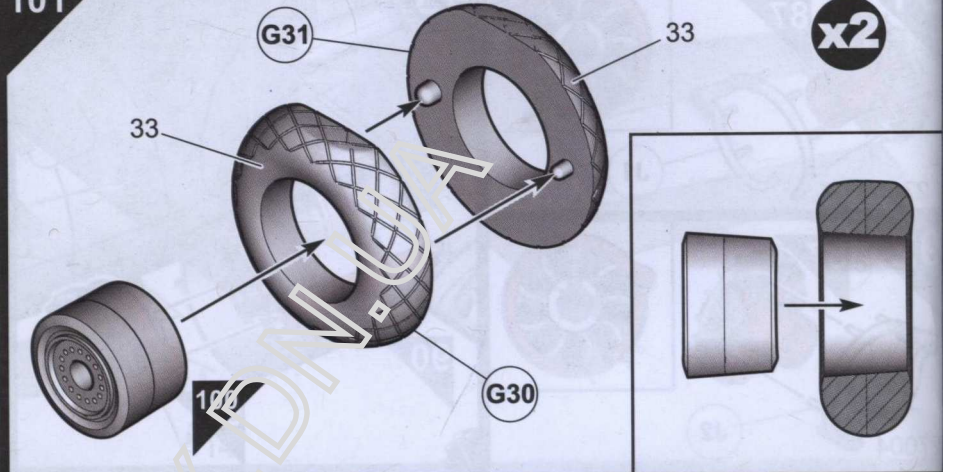

102

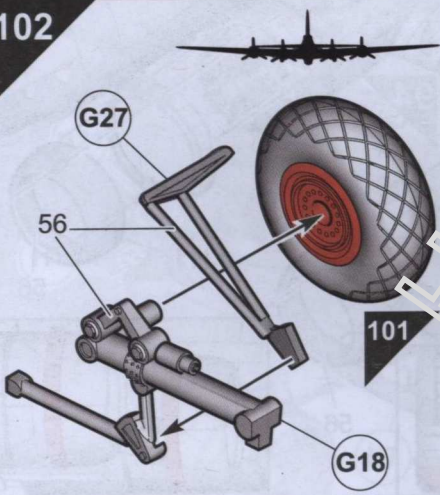

103

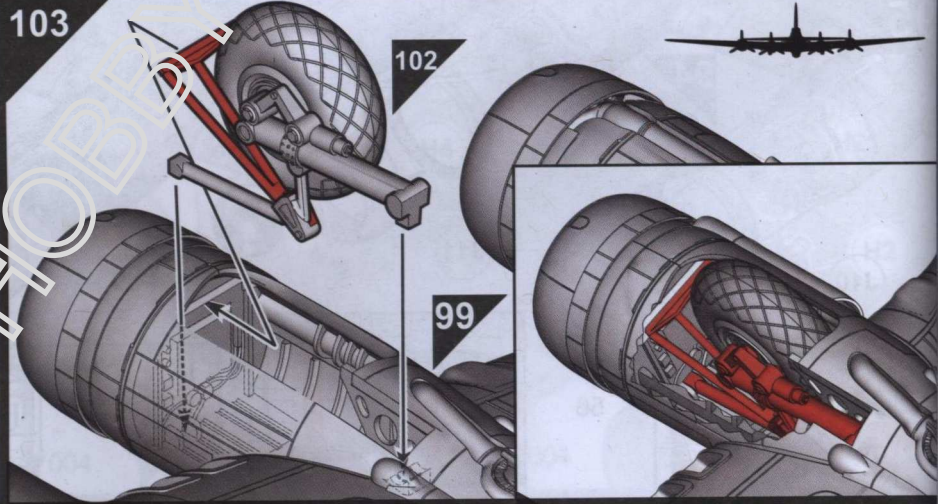

104

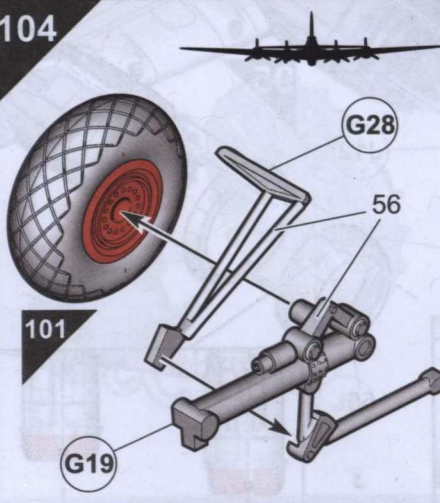

105

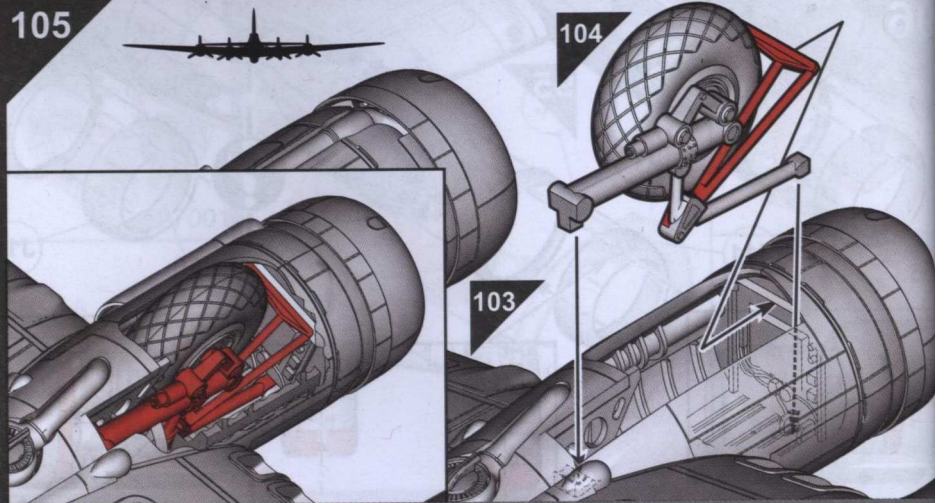

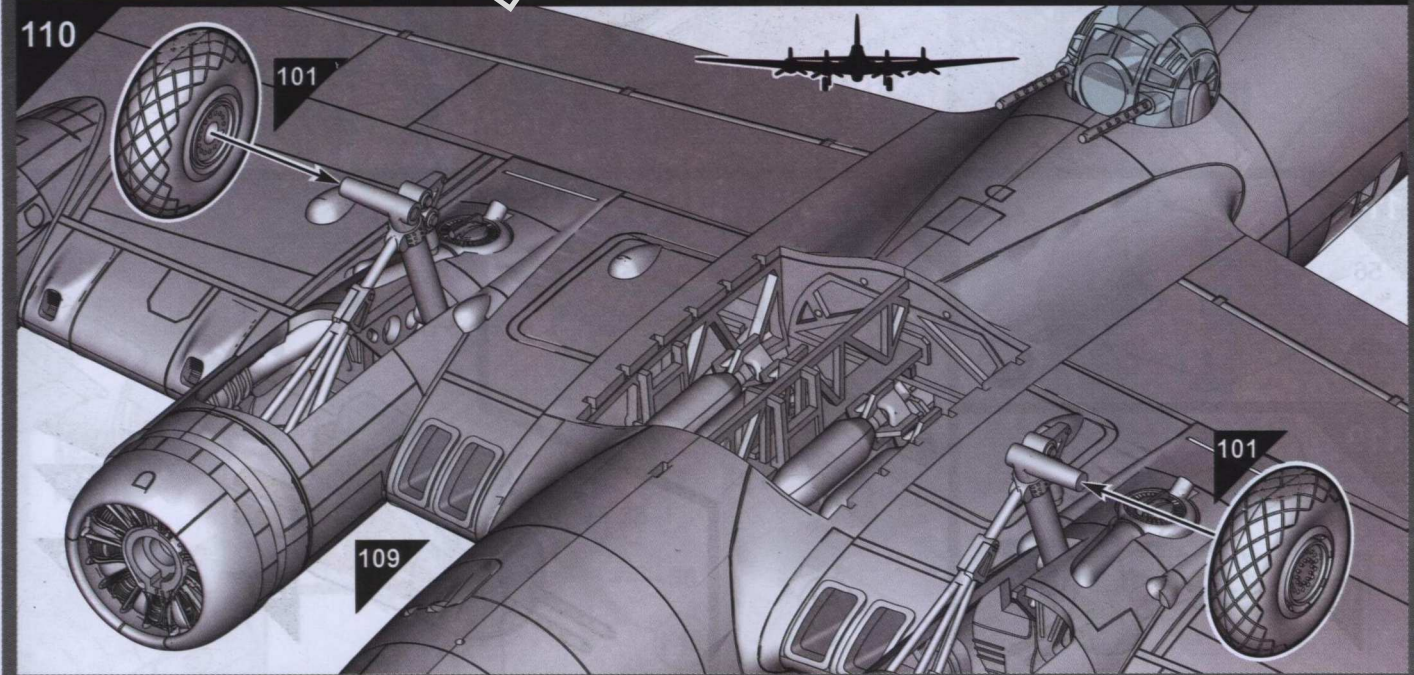
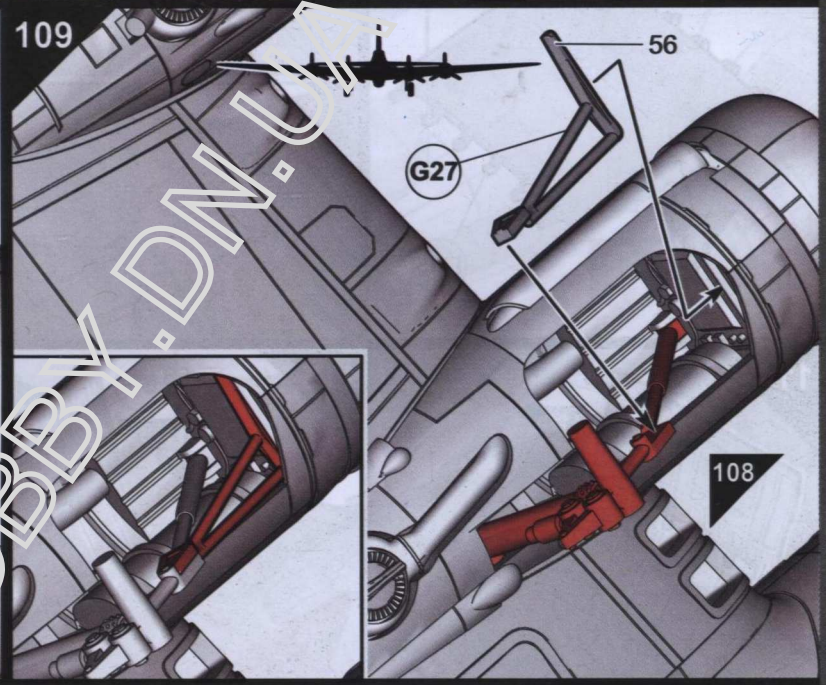
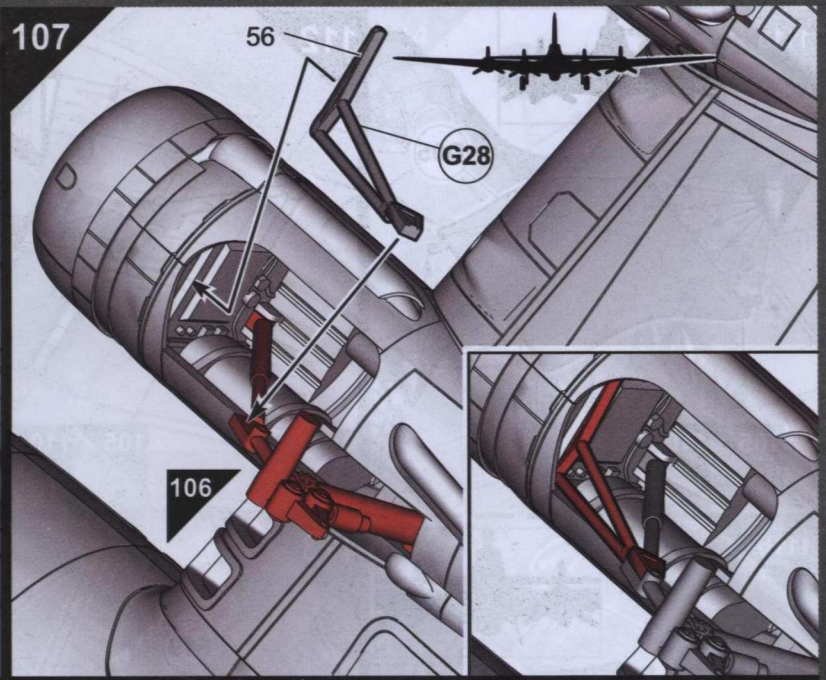
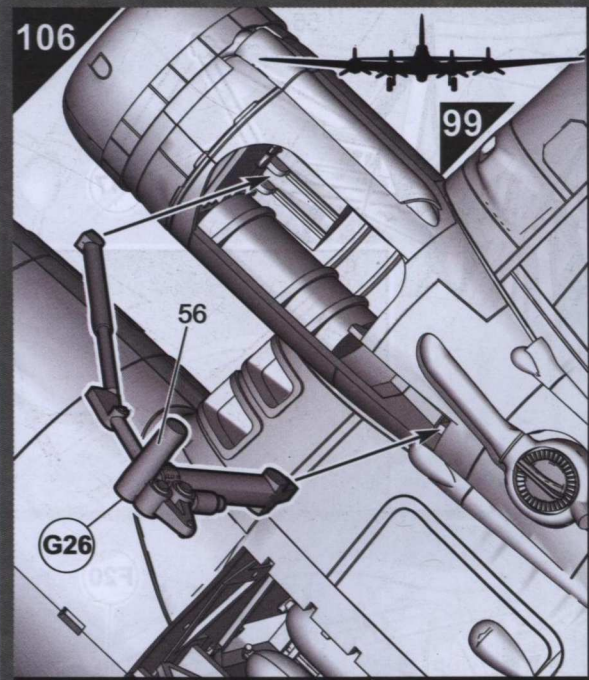



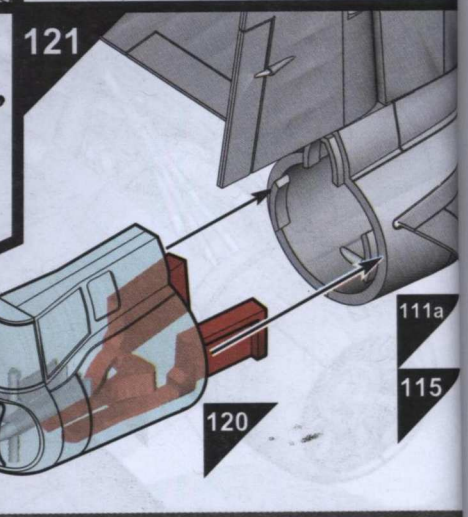
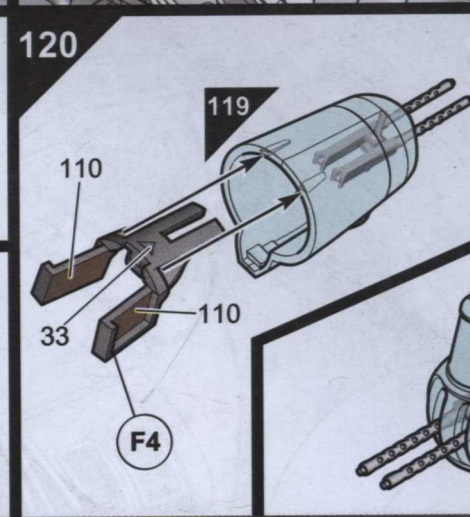
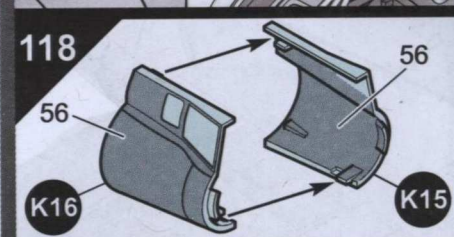
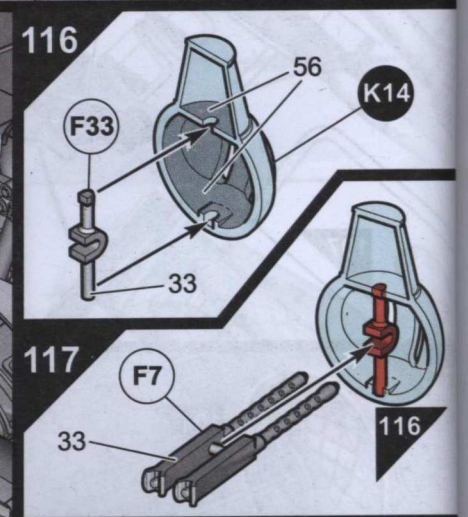
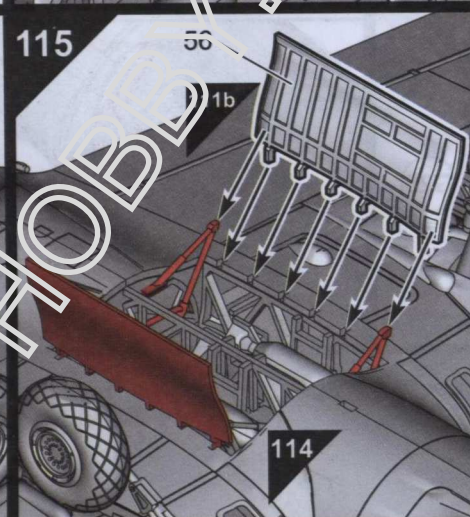
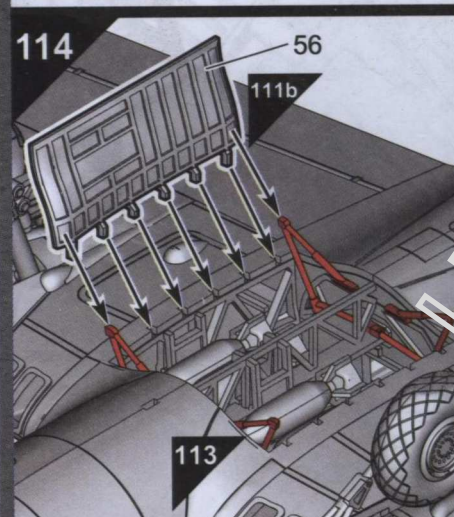
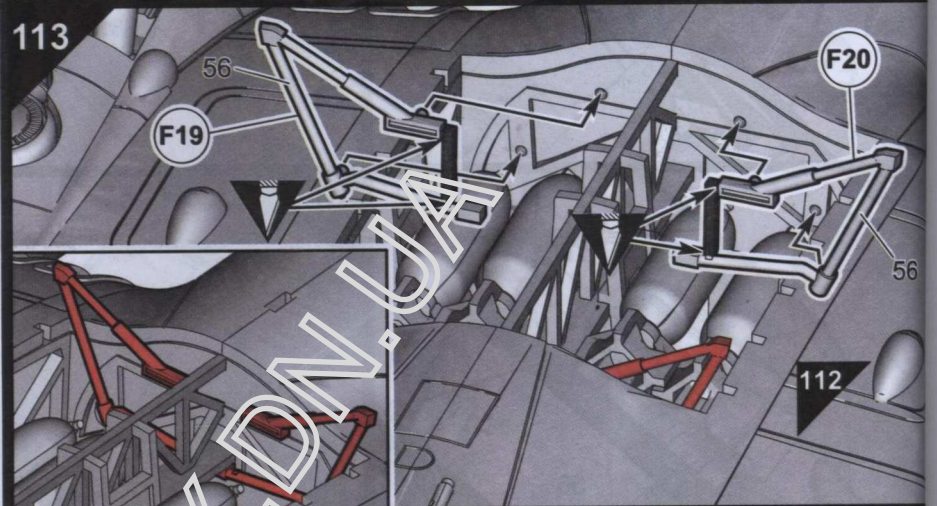
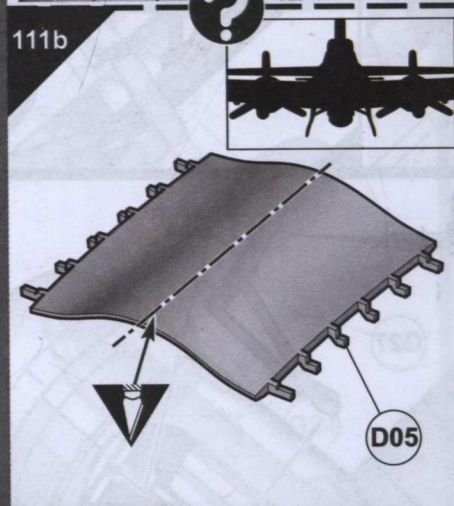
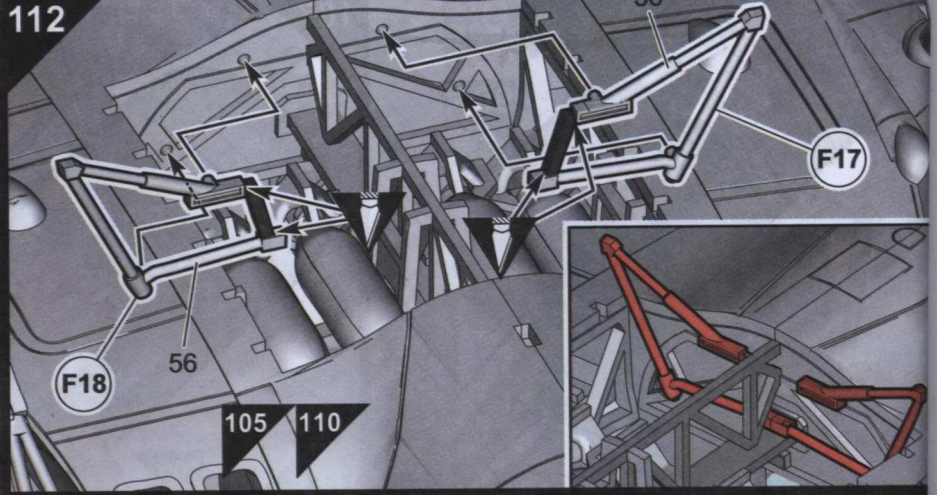
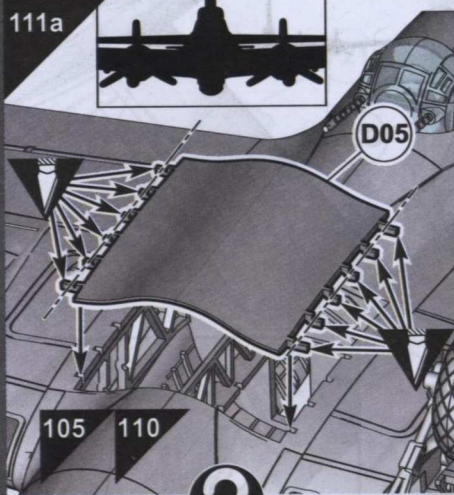

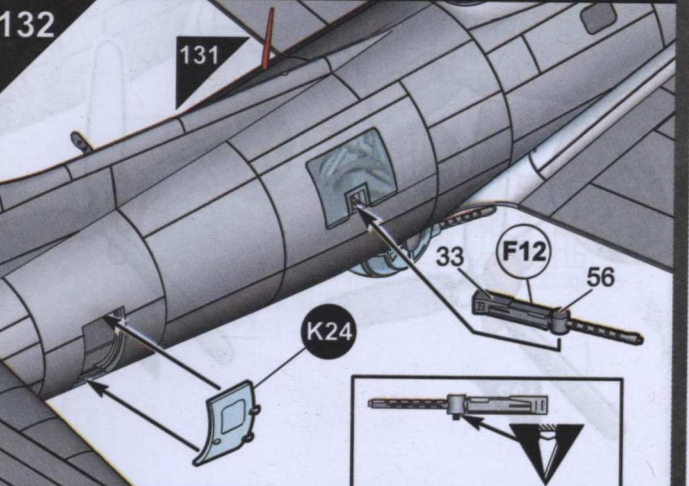
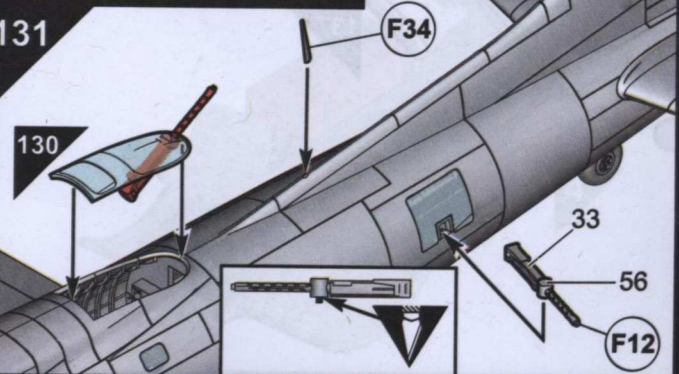
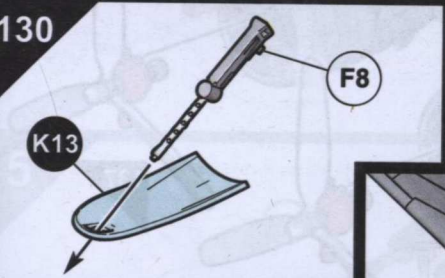
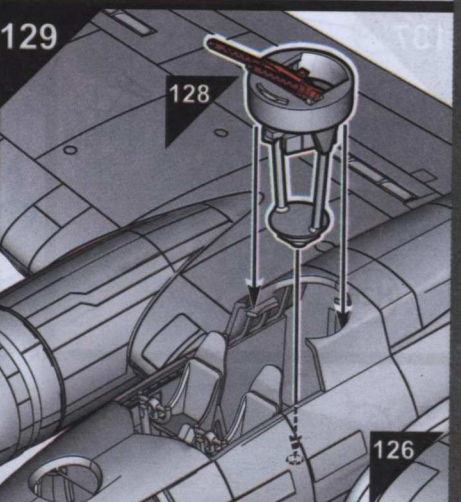
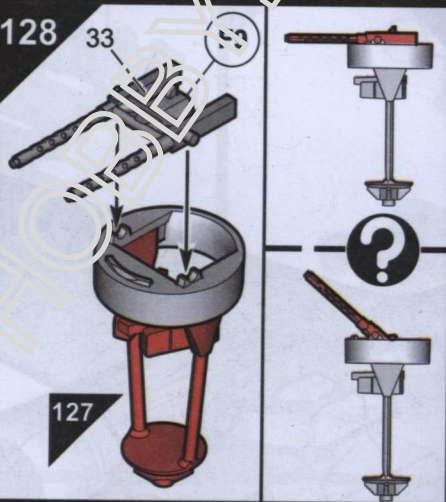
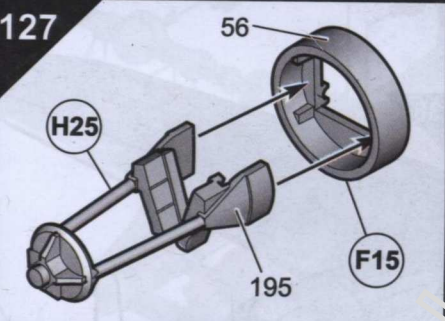
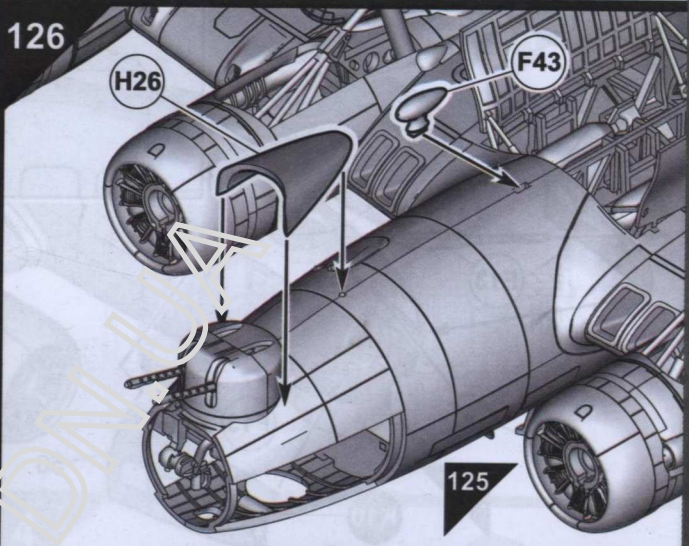
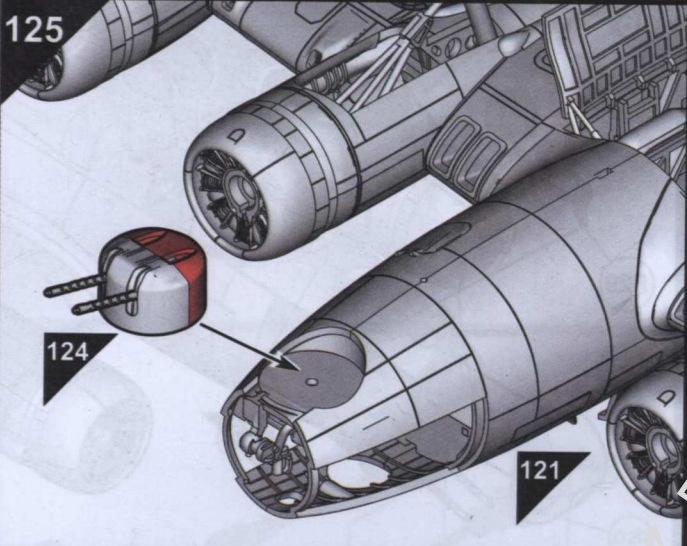
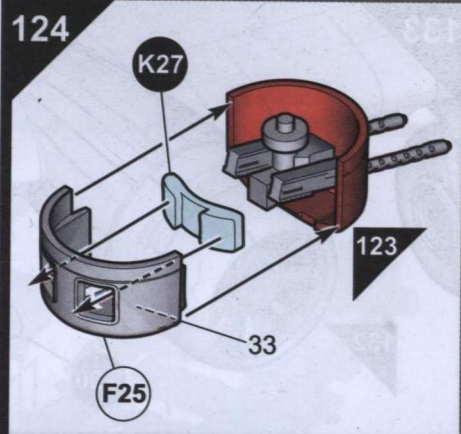
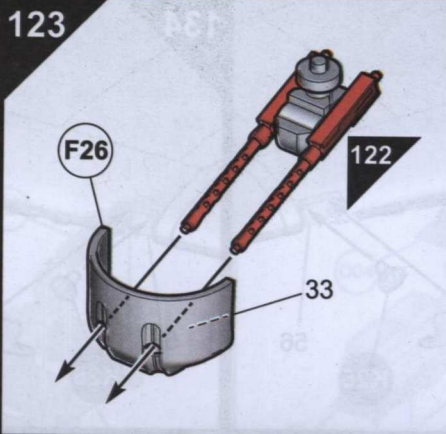
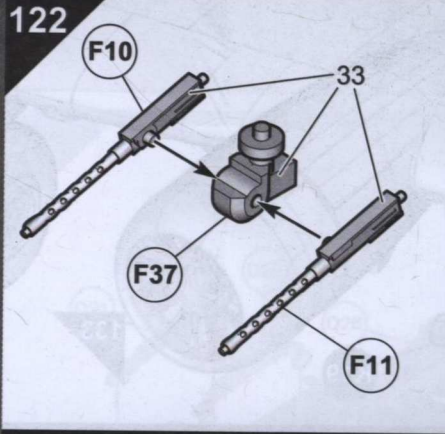

133

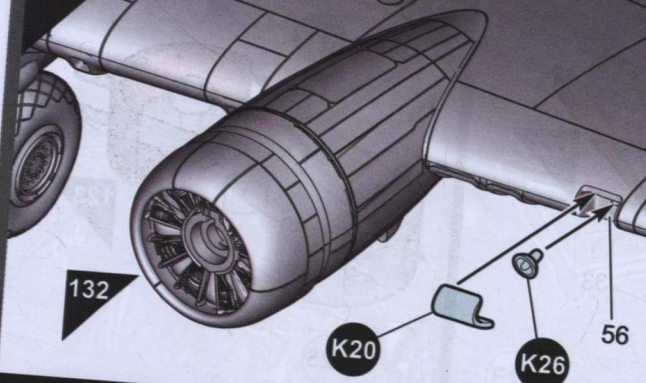

134

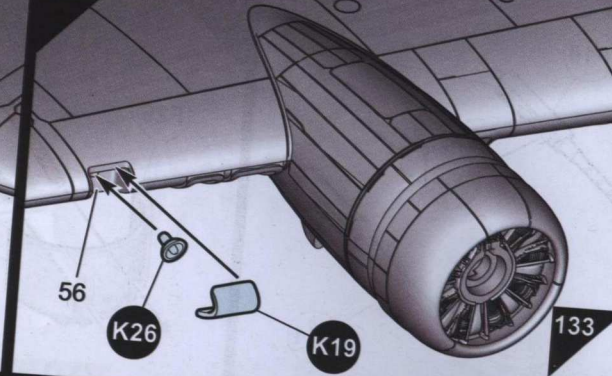

135

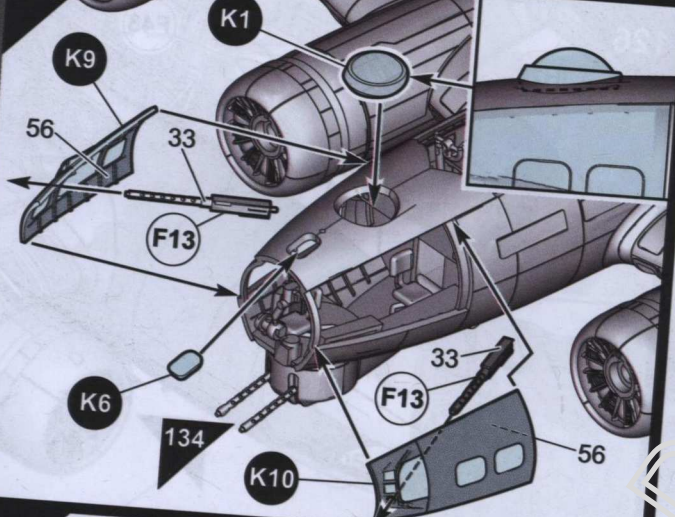

136

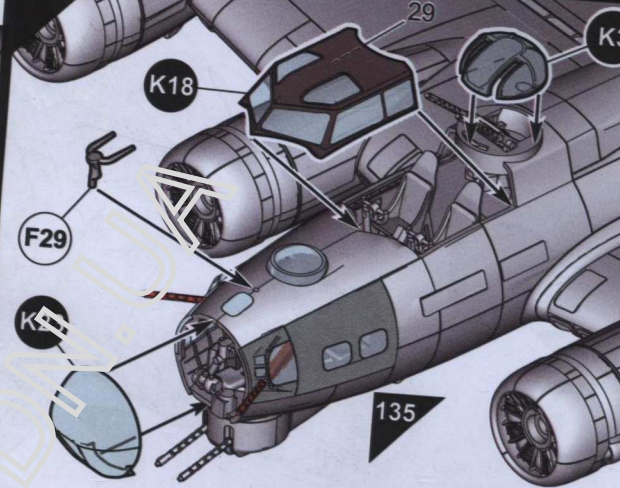

137

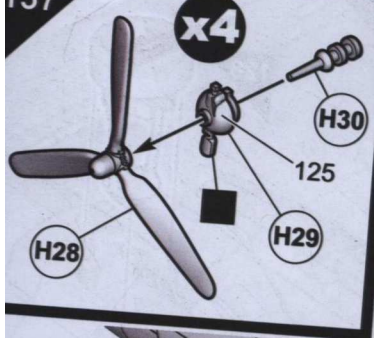

138

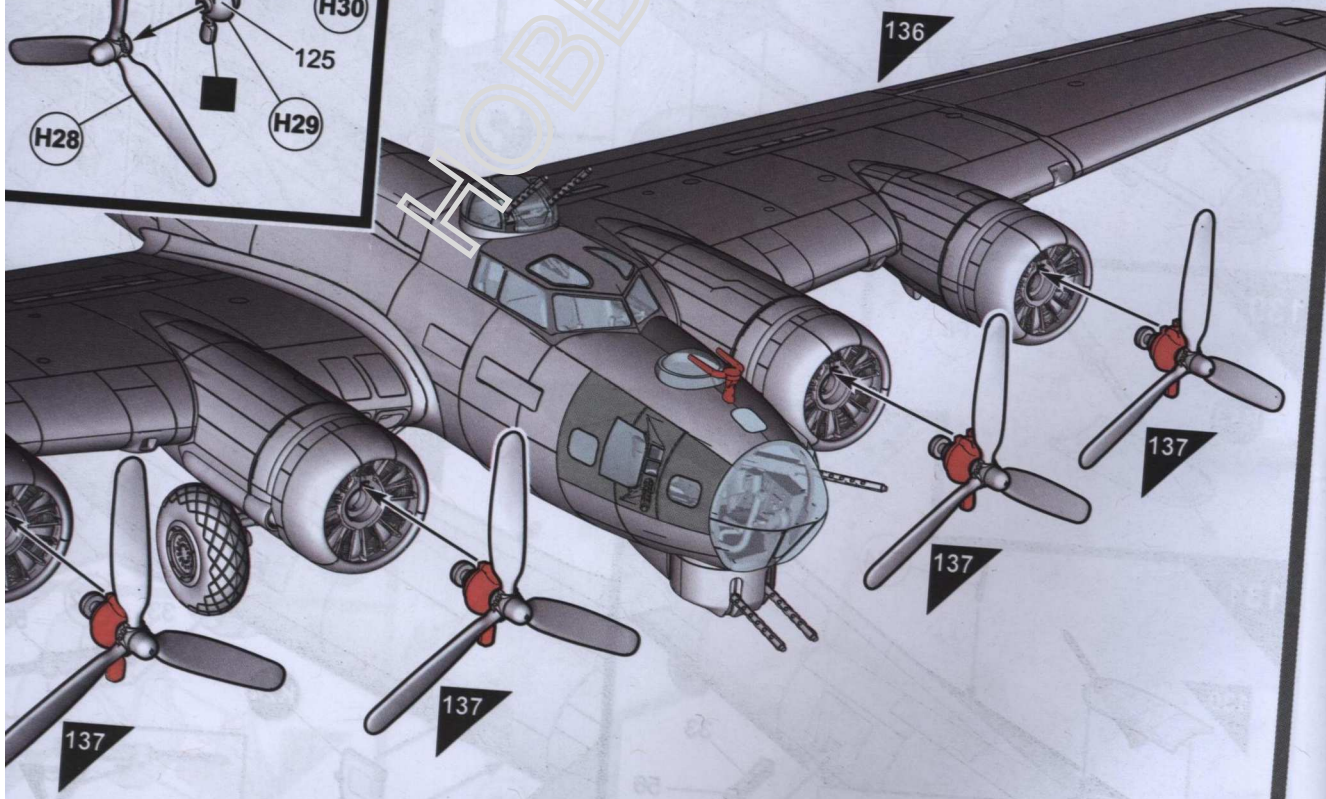

# Autocar U-7144-T

1

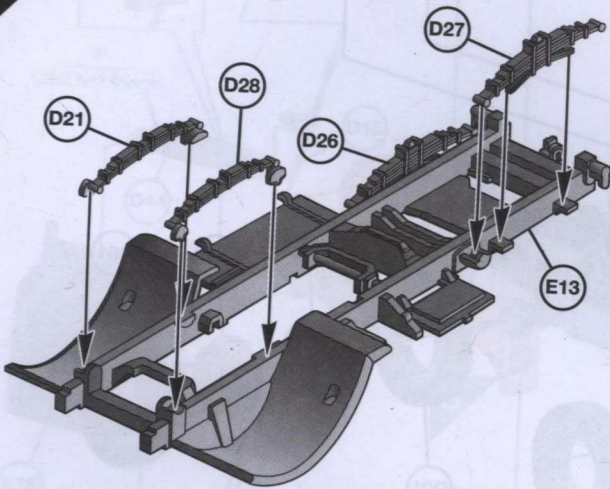

2

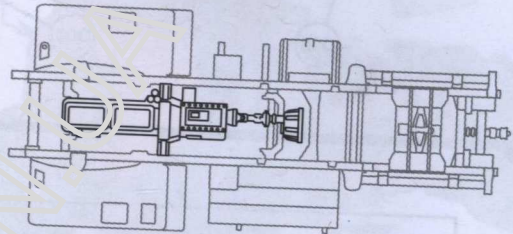
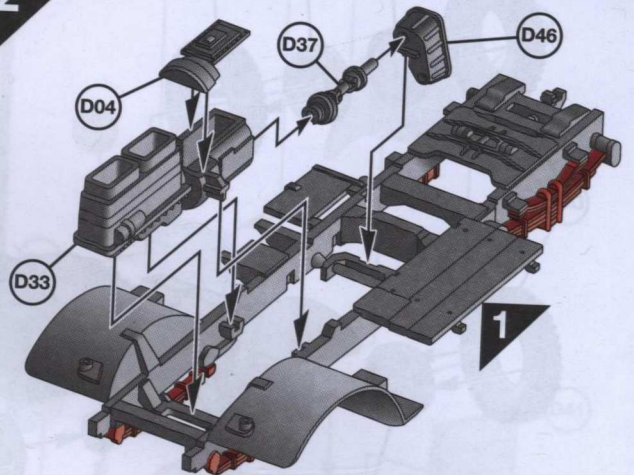

3

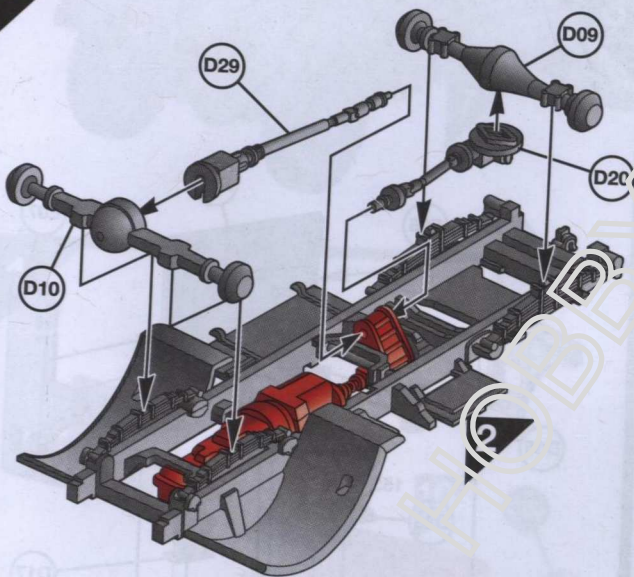

4

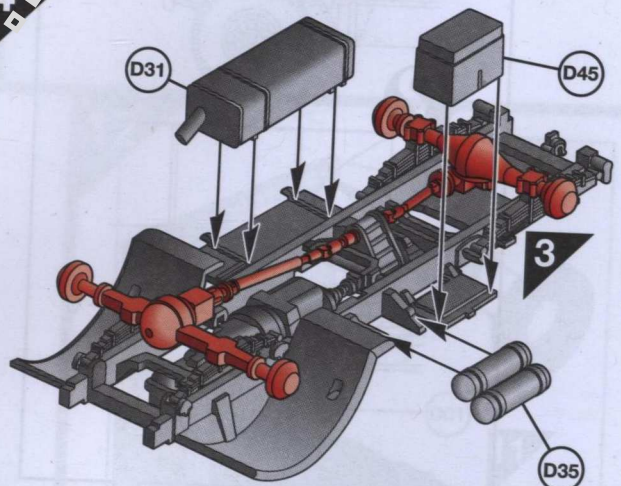

5

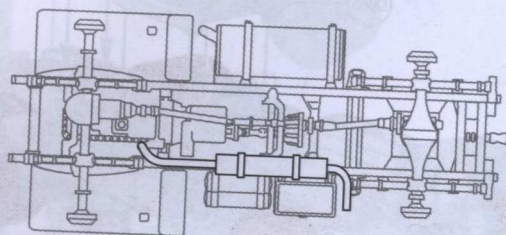
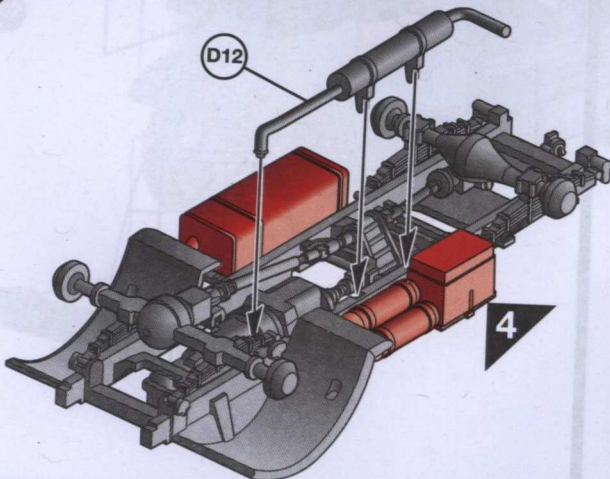

6

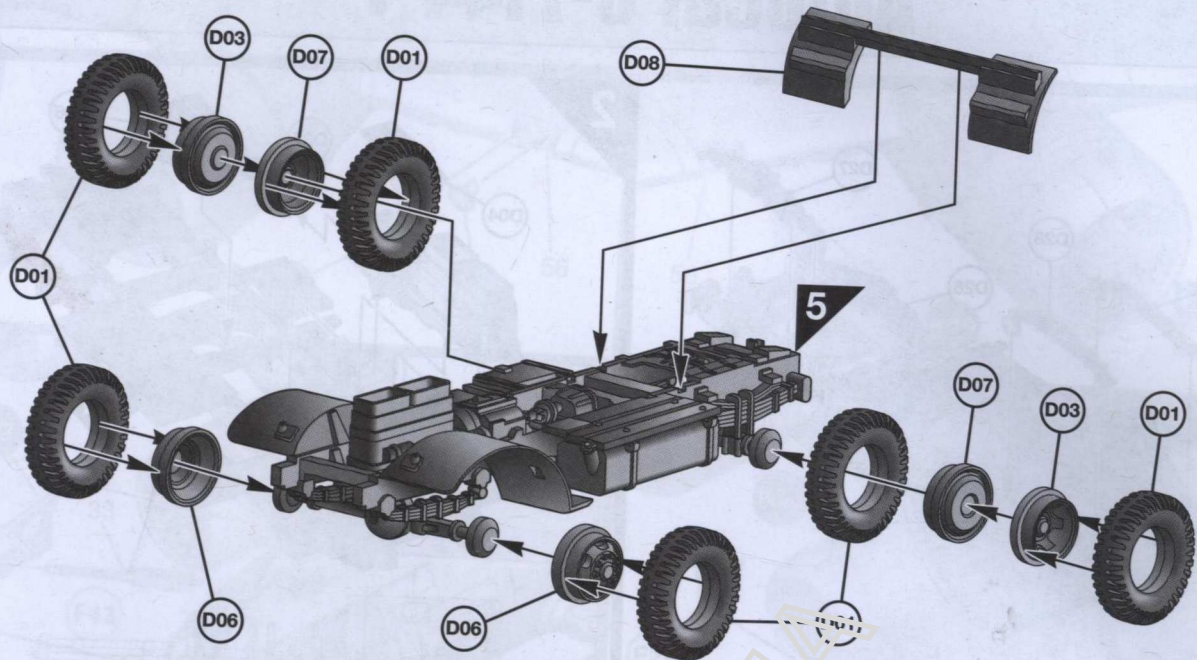

7

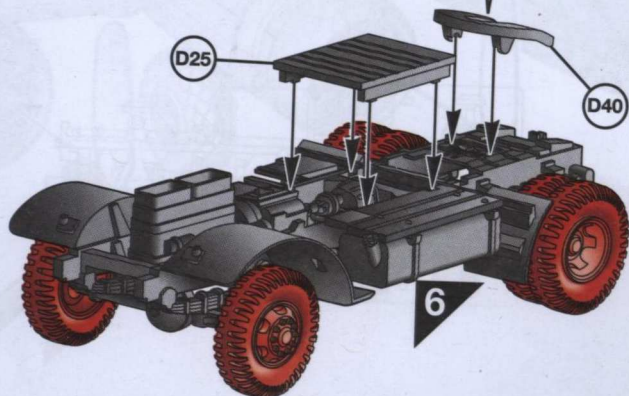
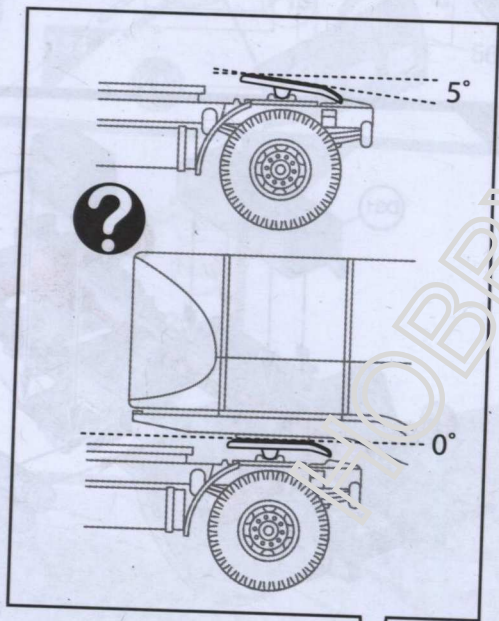

8

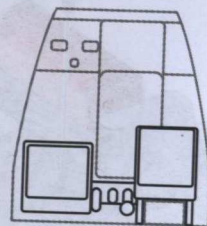
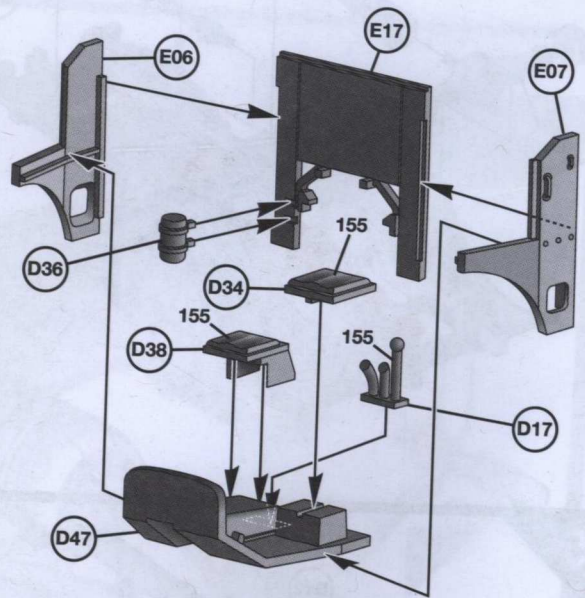

9

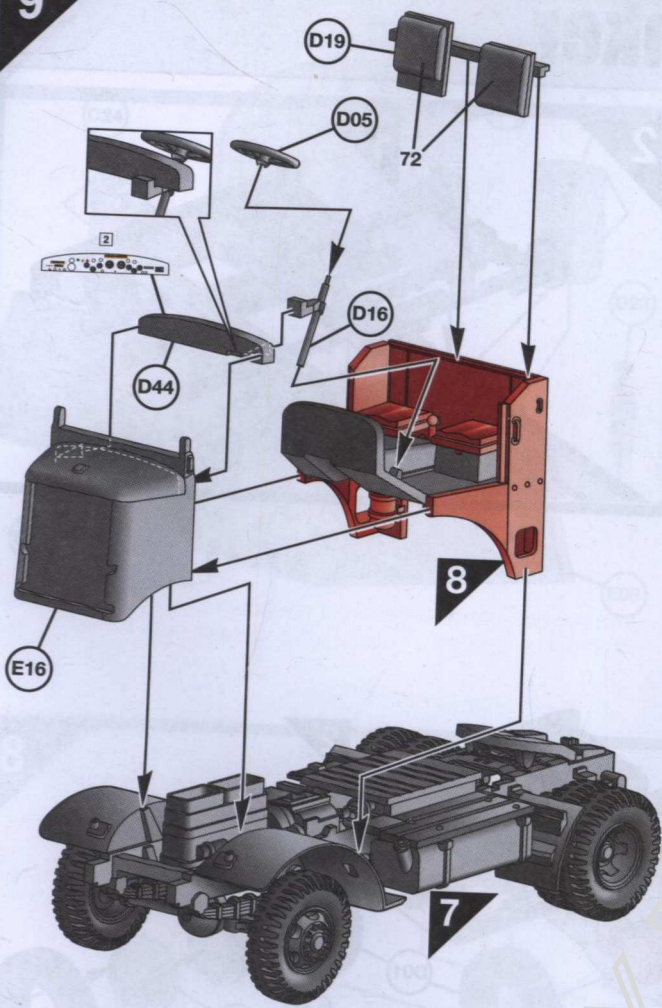

10

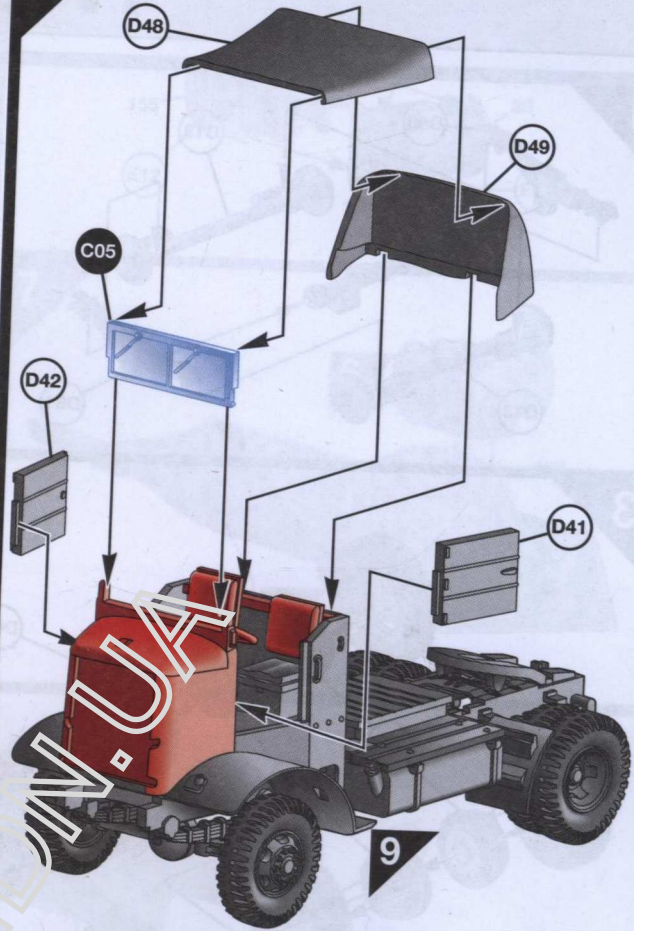

11

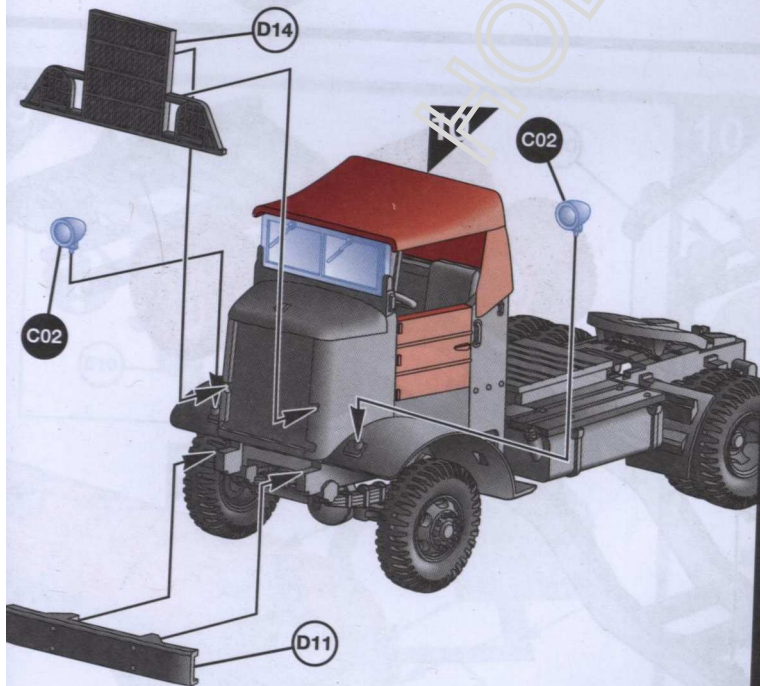

12

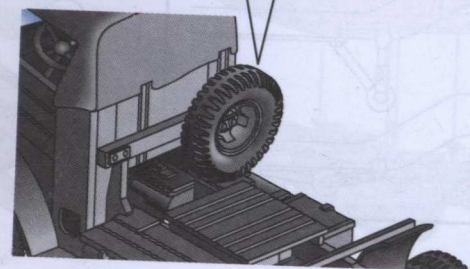
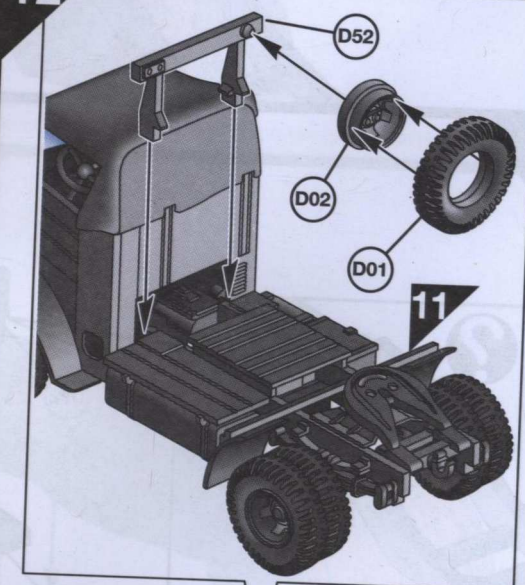

# F1 Tanker

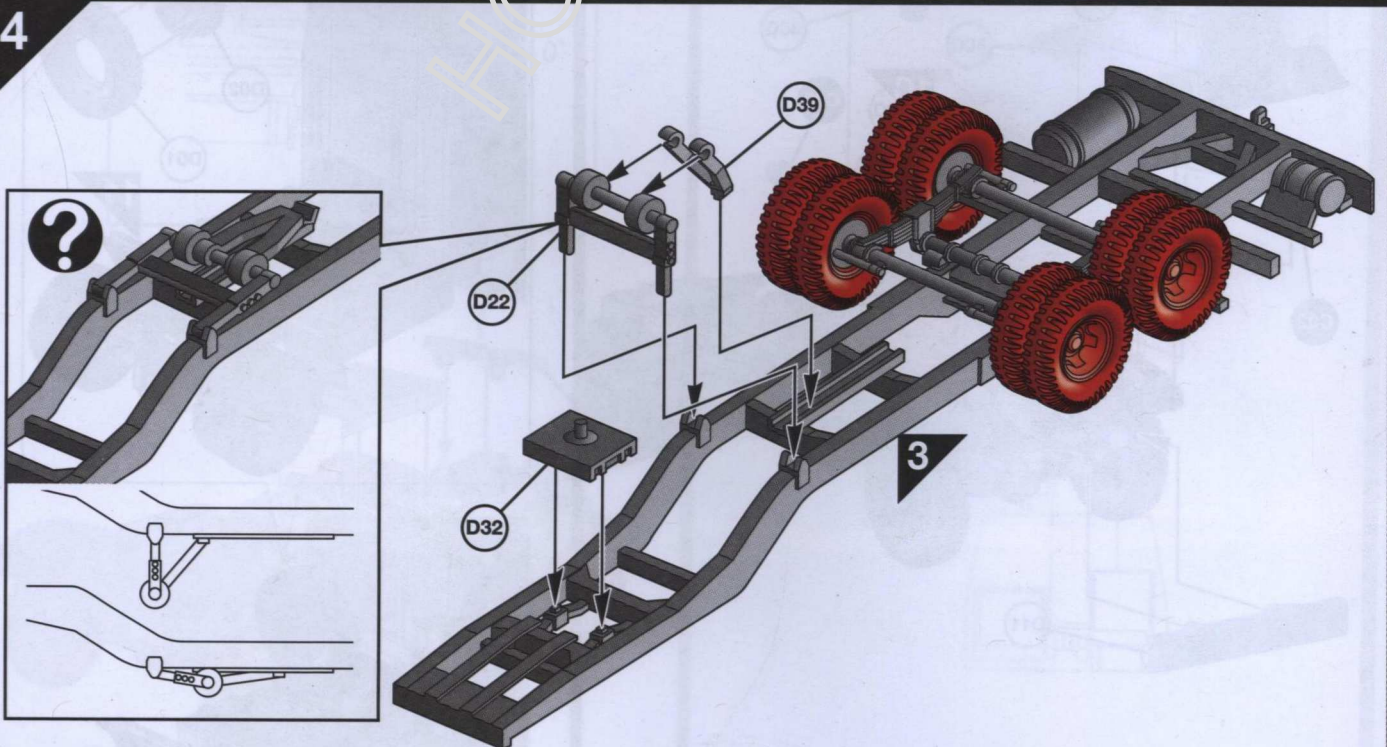
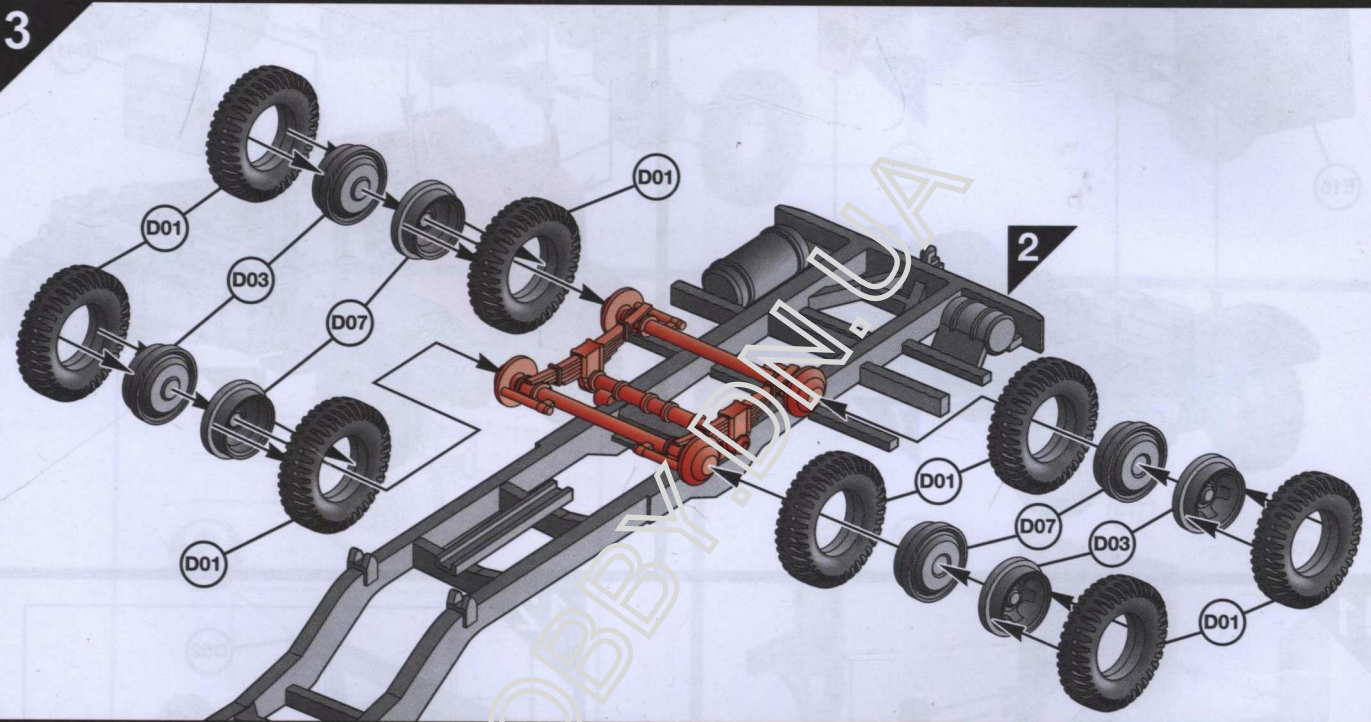
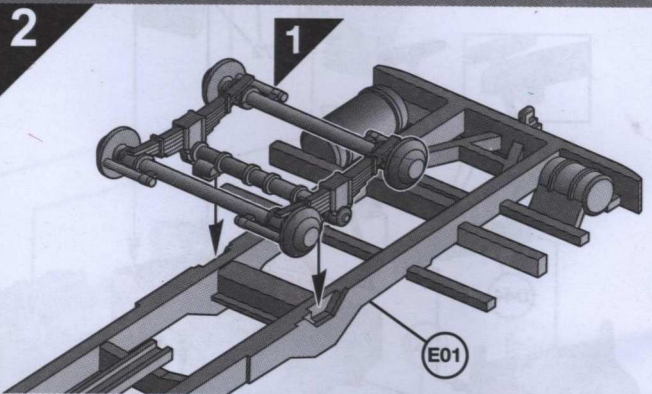
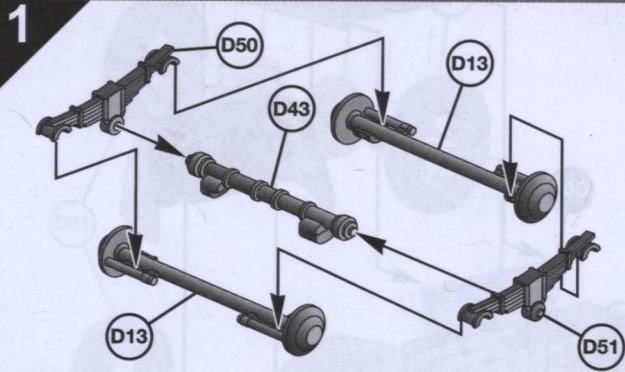

5

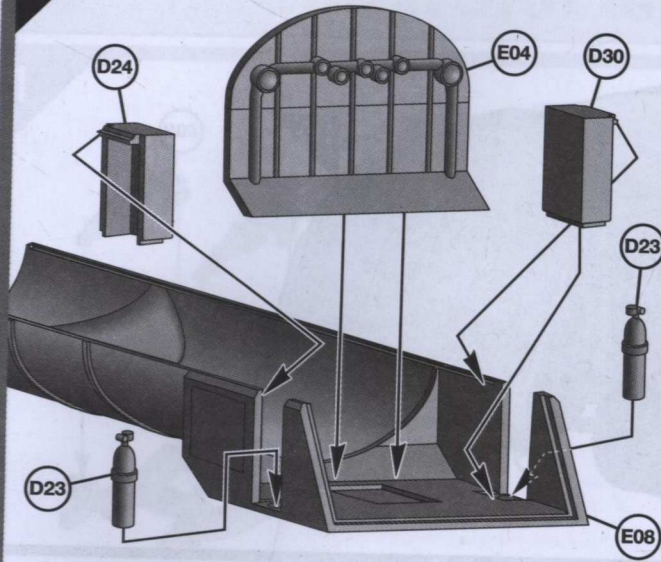

6

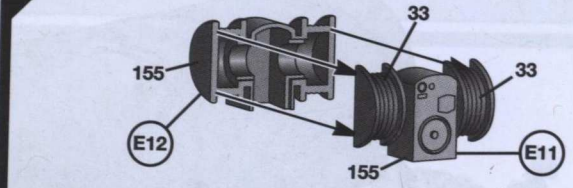

7

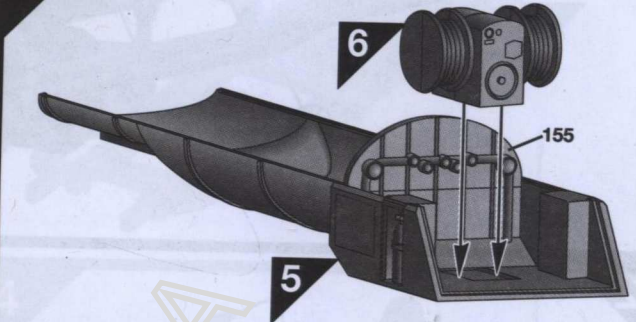

8

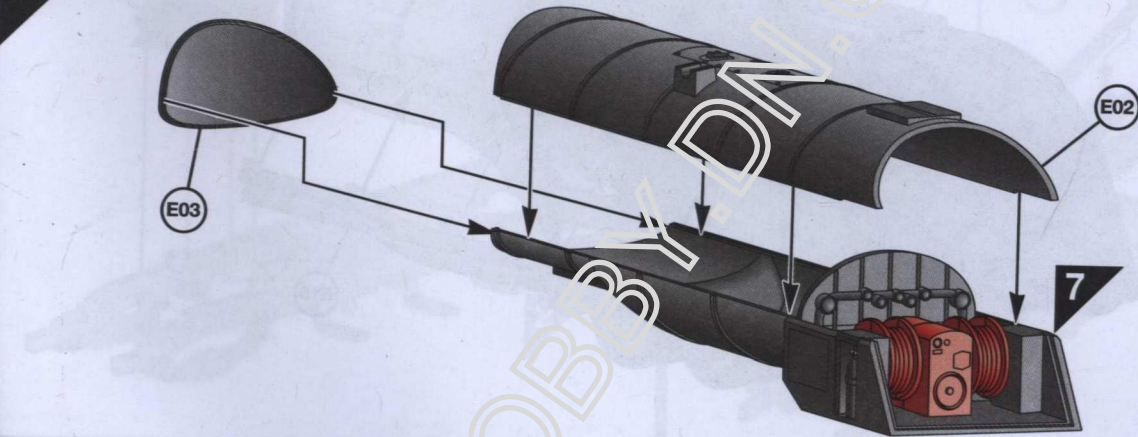

9

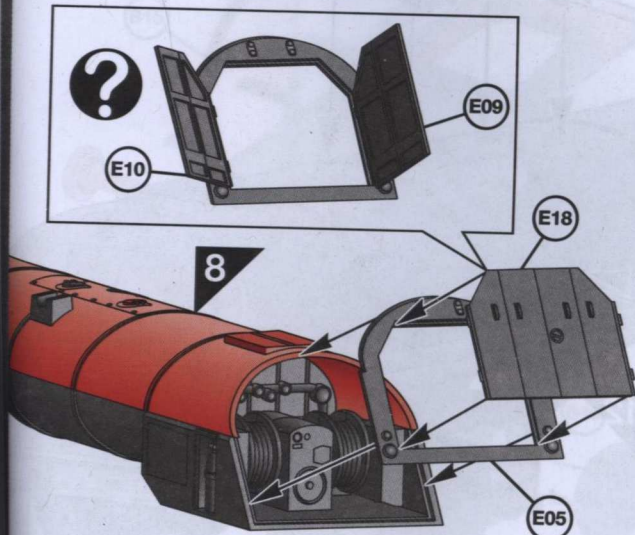

10

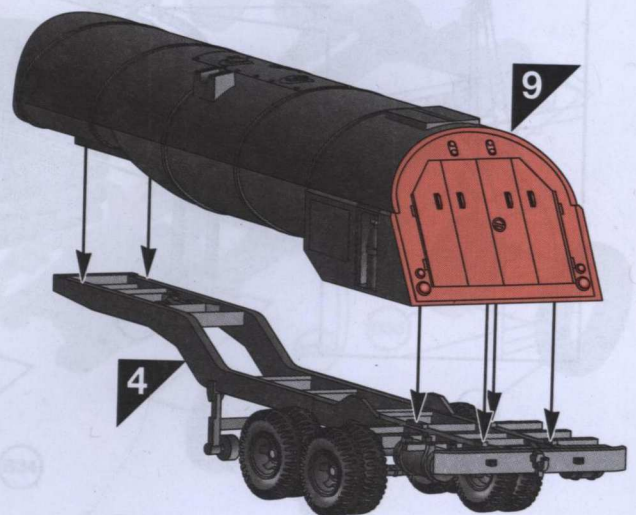



11



12

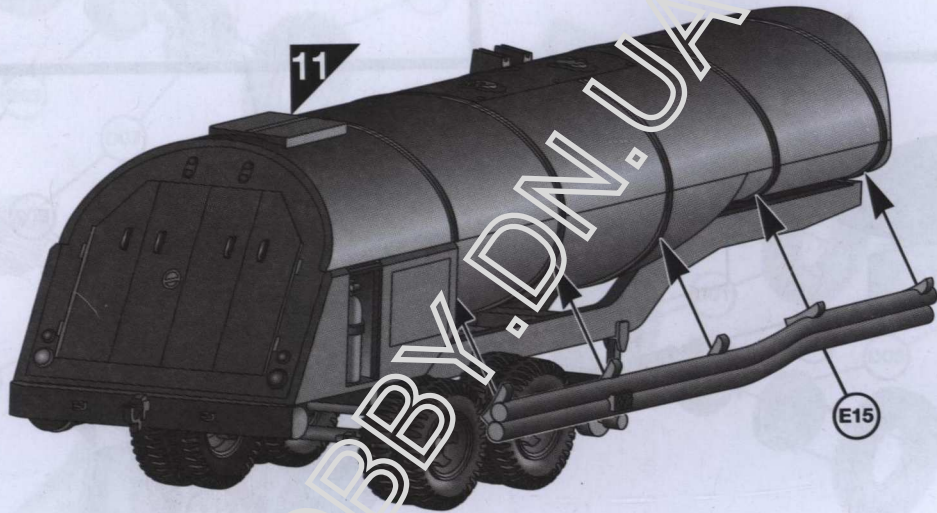

13

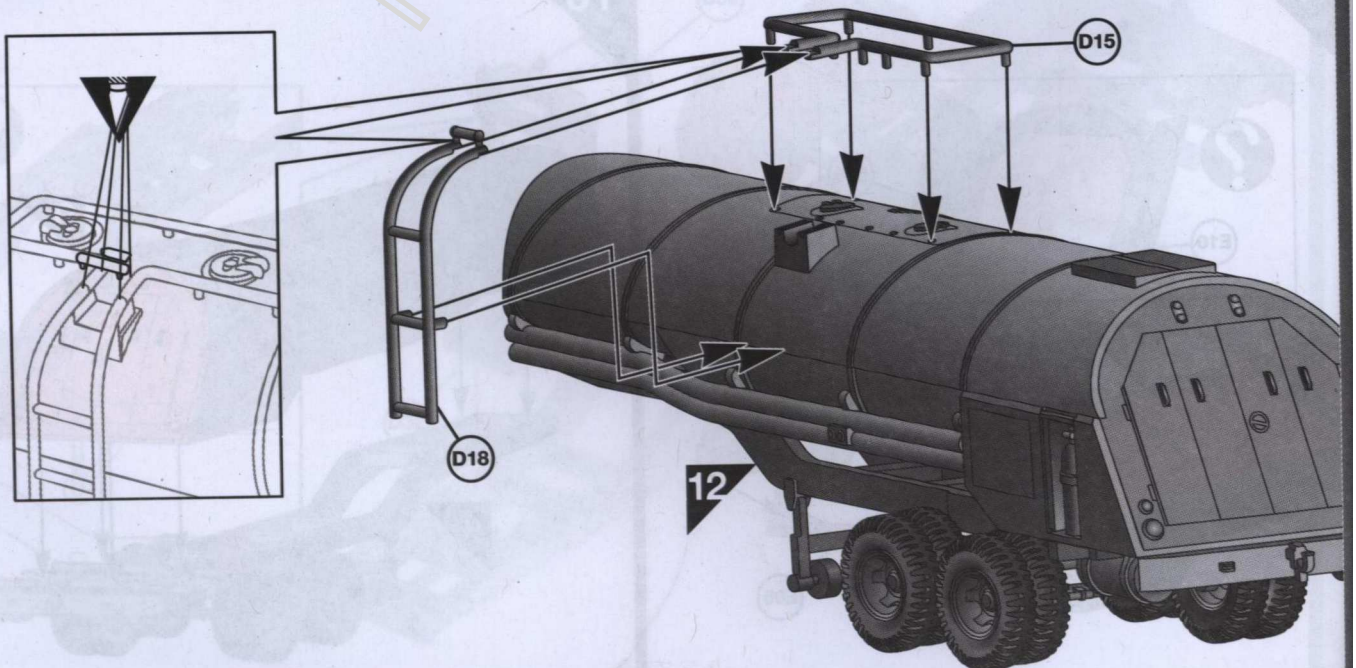

# Chevrolet M6 Bomb Truck

1

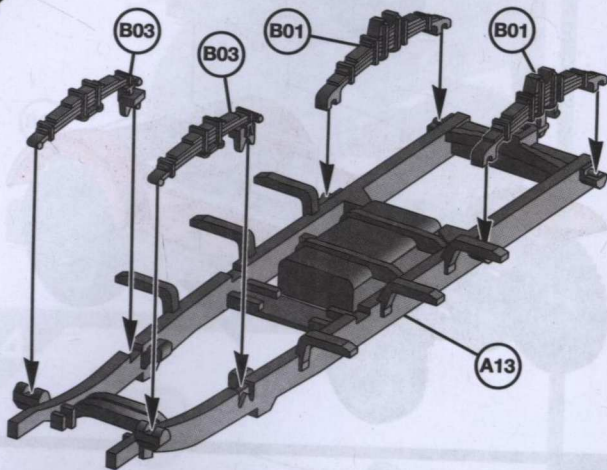

2

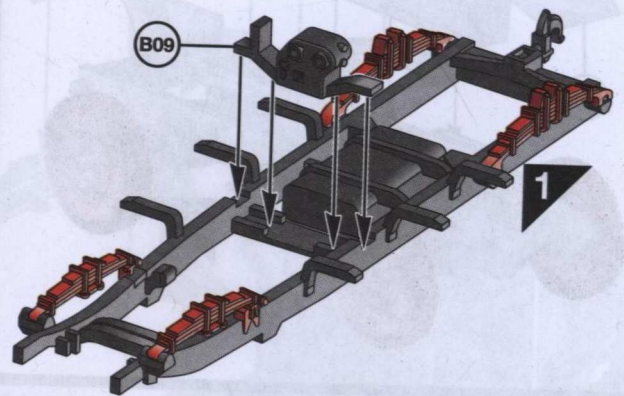

3

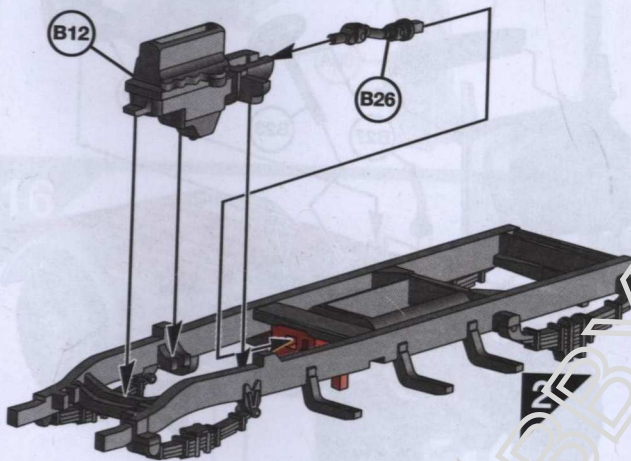

4

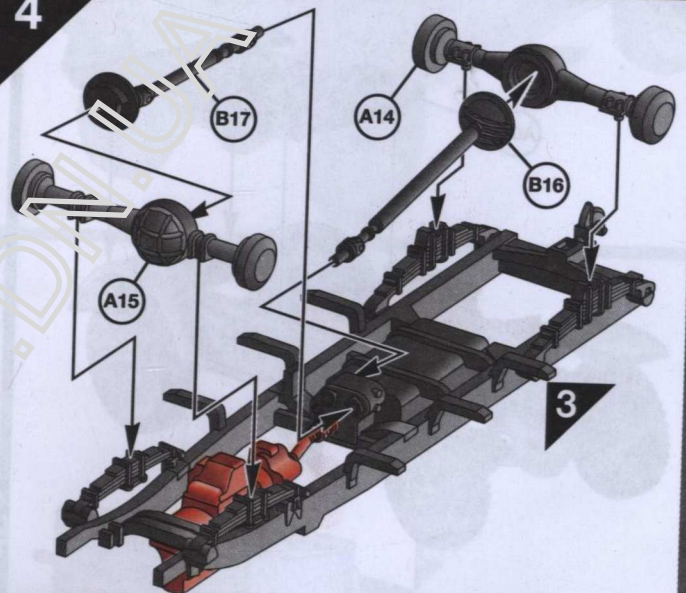

5

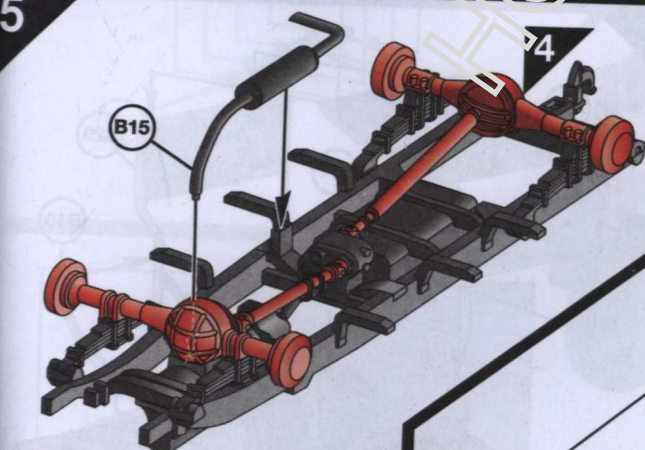

6

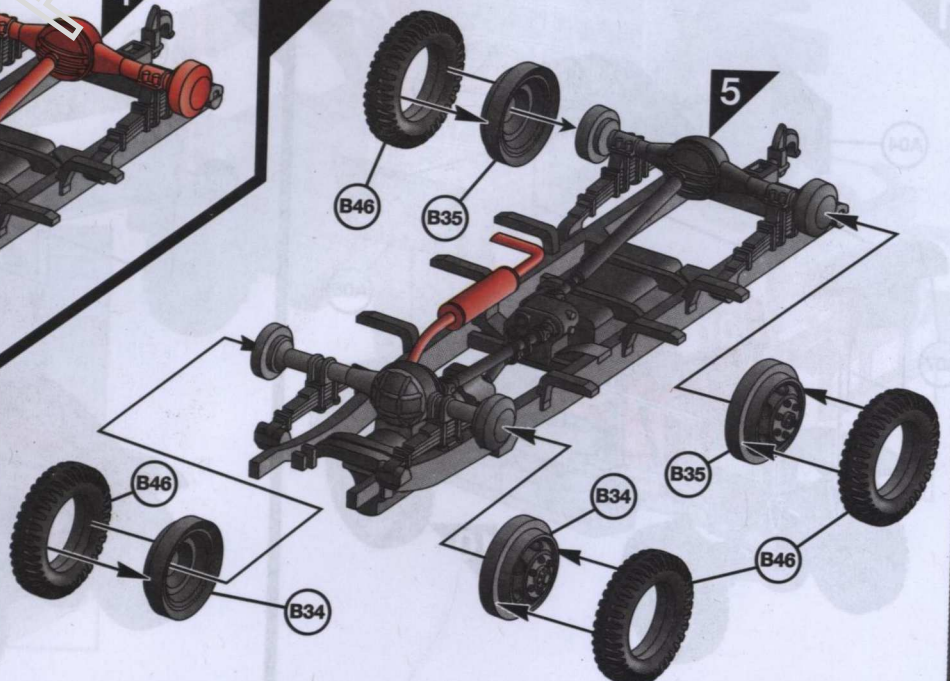

Chevrolet M6 Bomb Truck

7

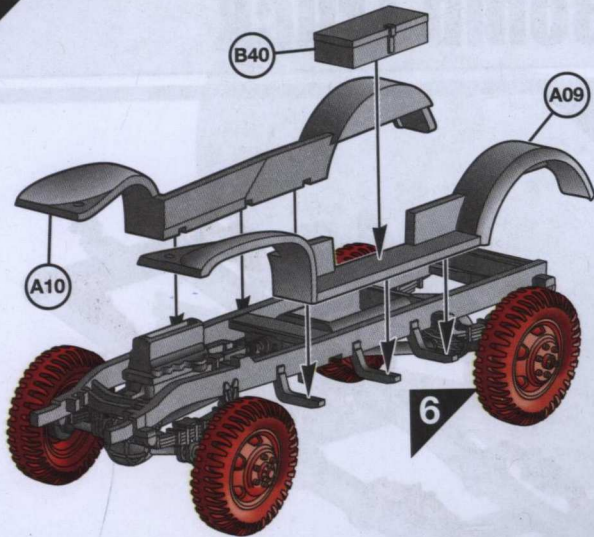

8

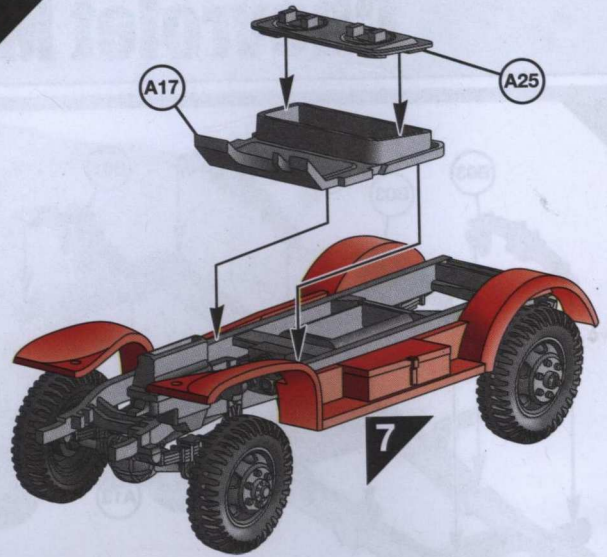

9

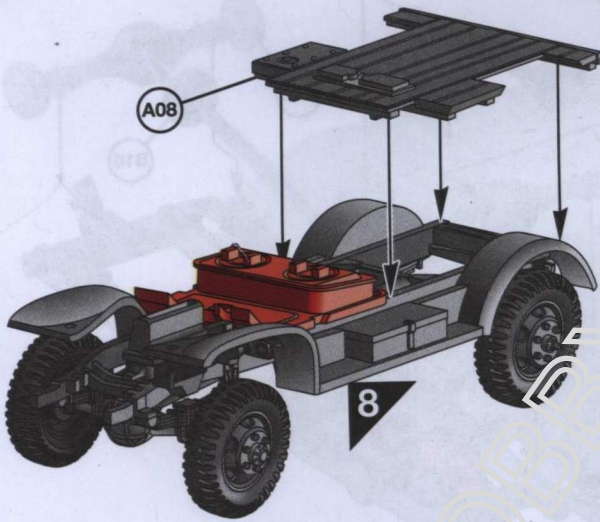

10

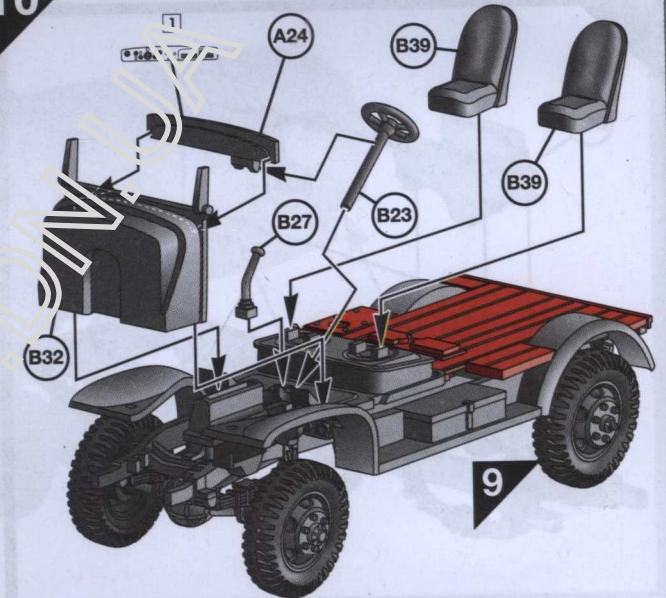

11

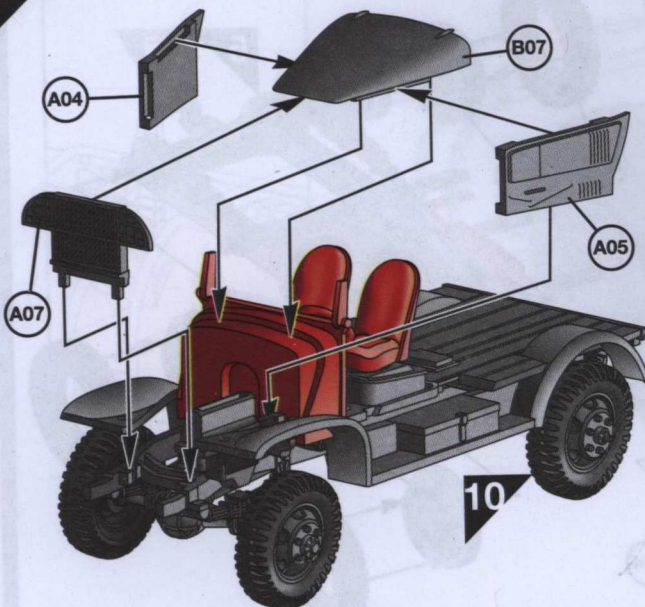

12

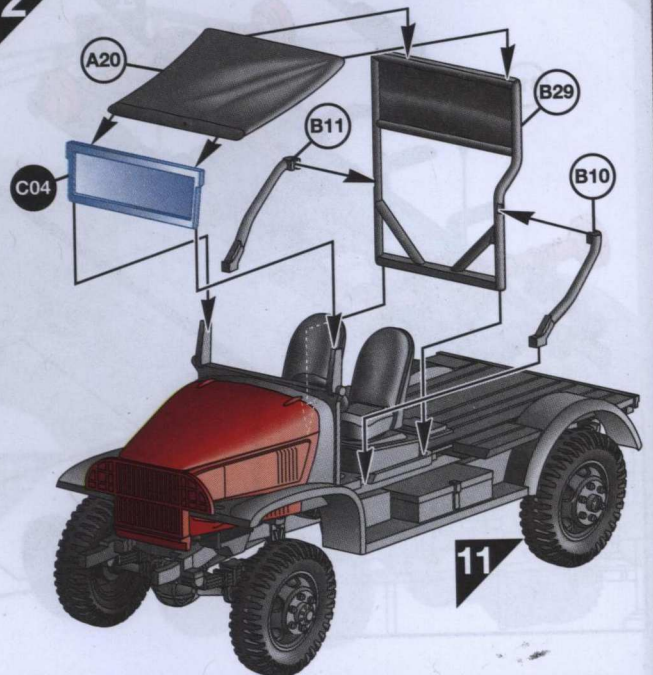

# Chevrolet M6 Bomb Truck

13

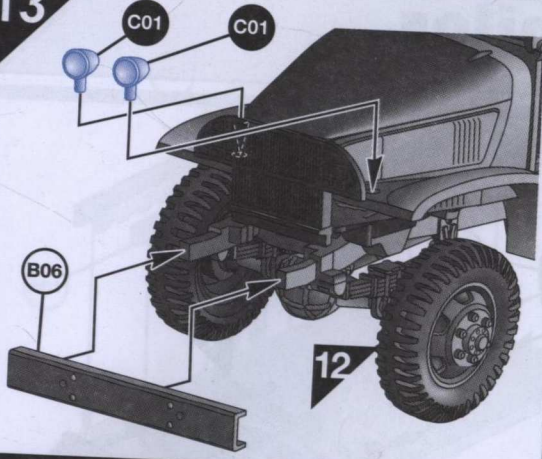

15

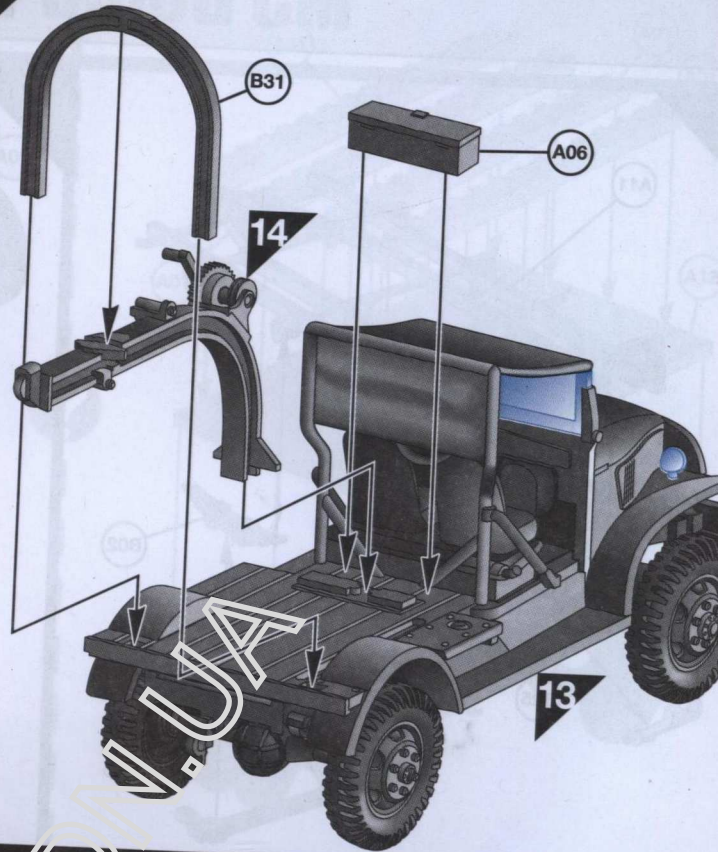

14

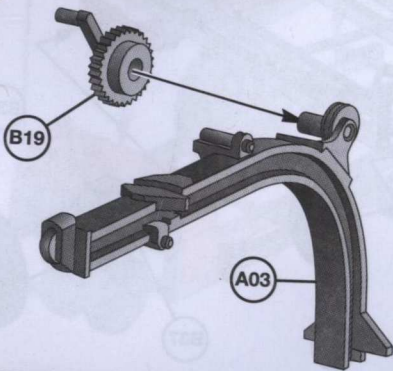

16

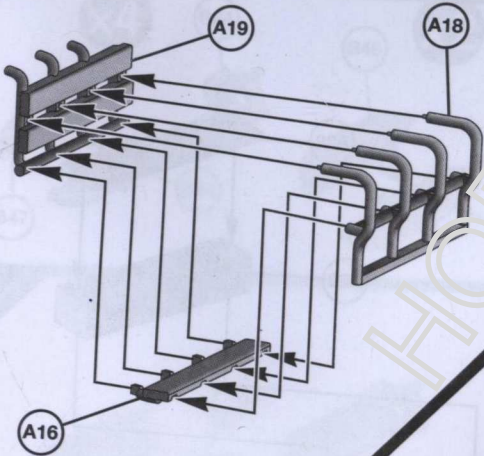

17

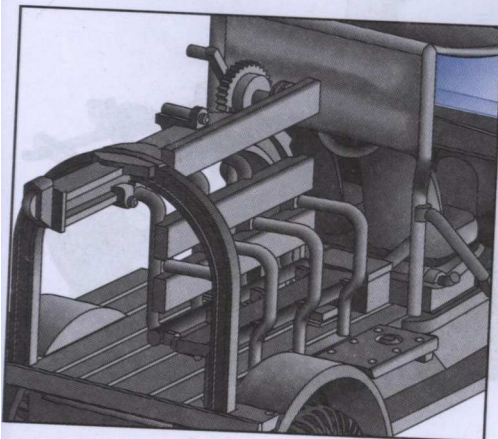
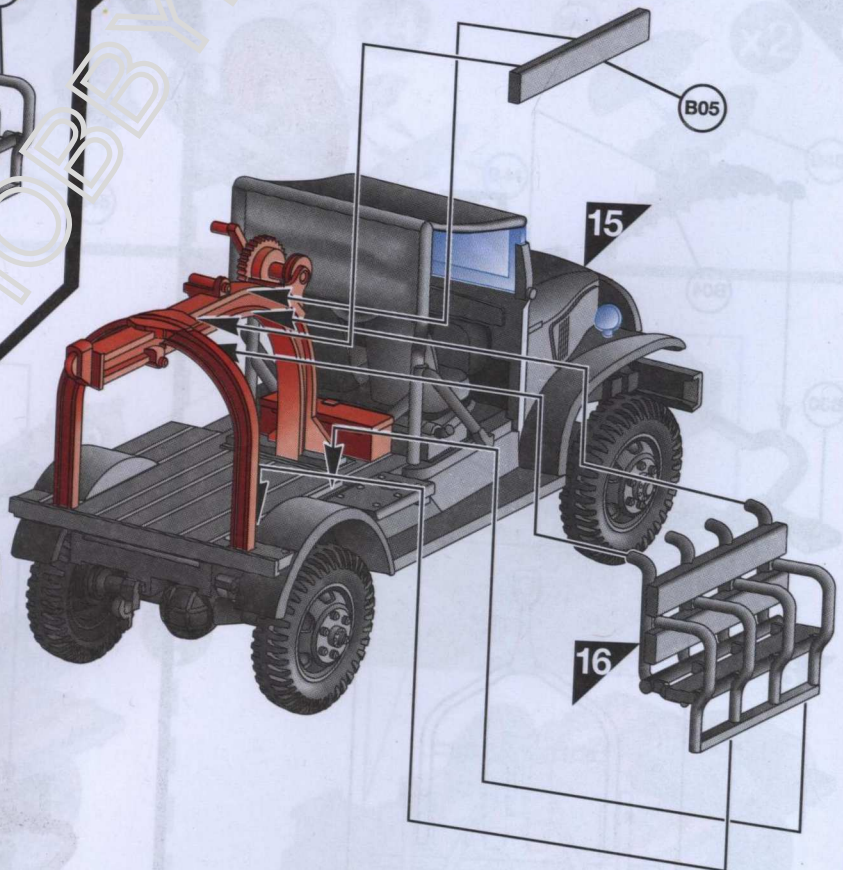

# M5 Bomb Trailer

1

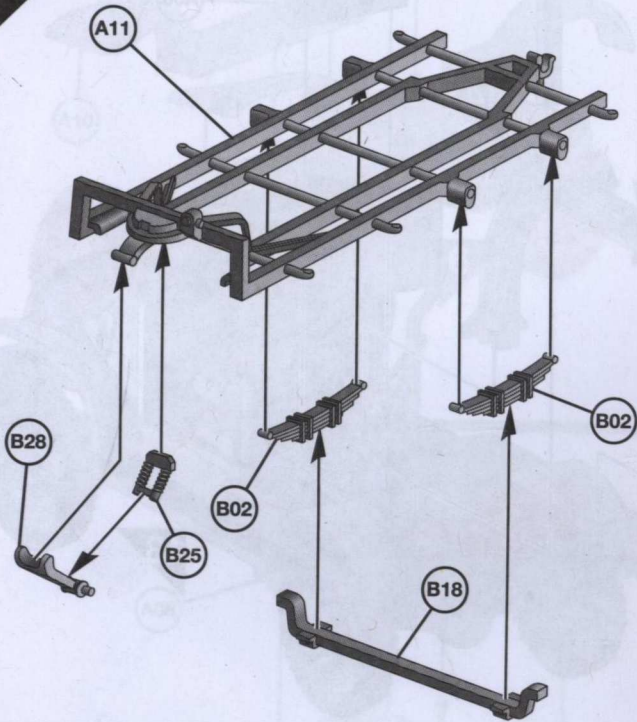

2

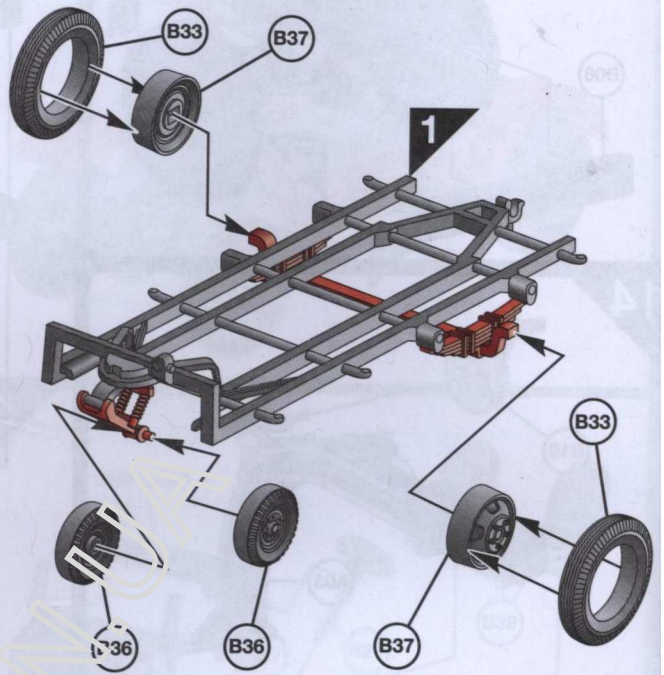

3

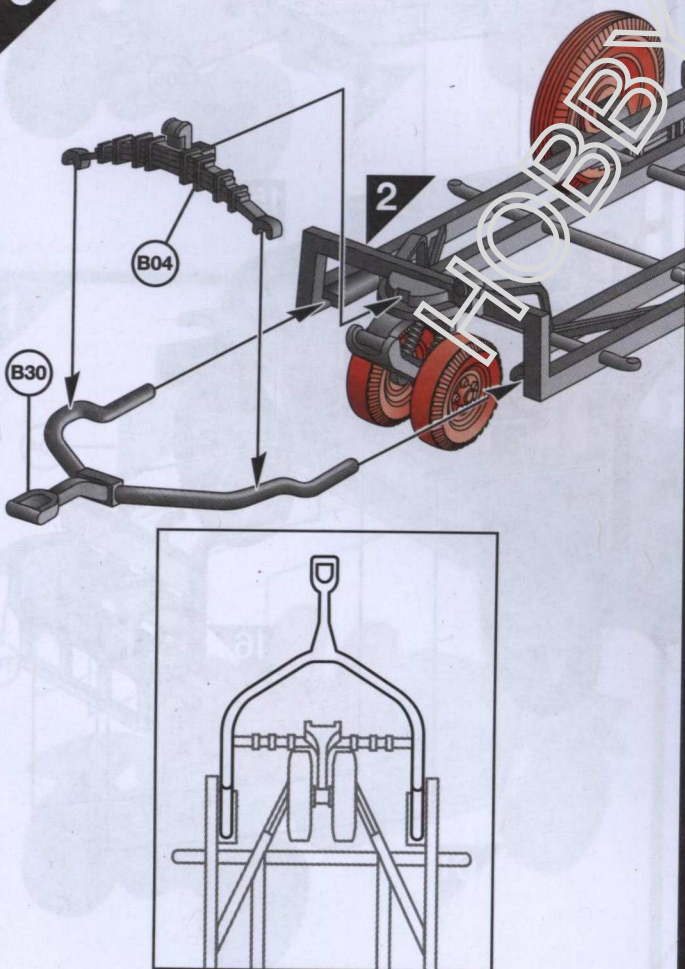

4

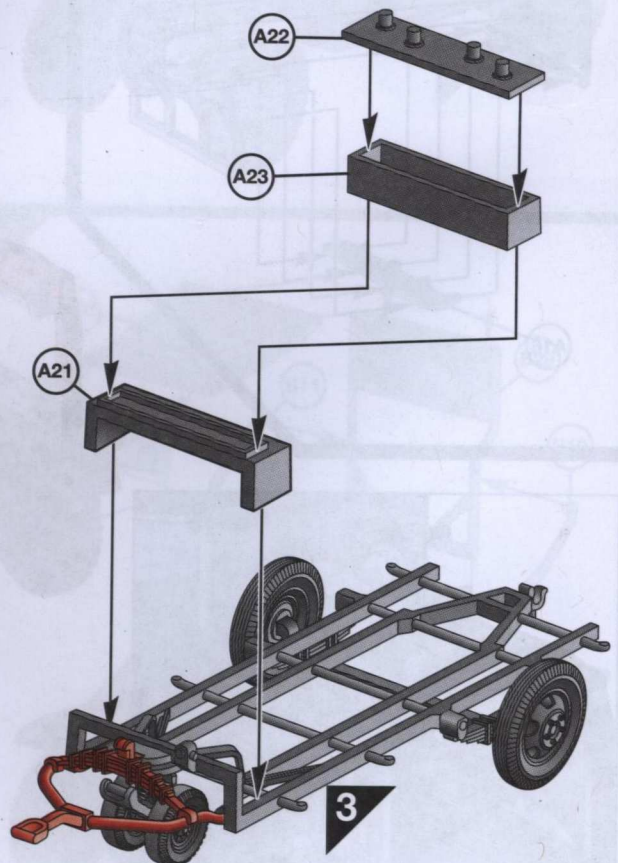

M5 Bomb Trailer

5

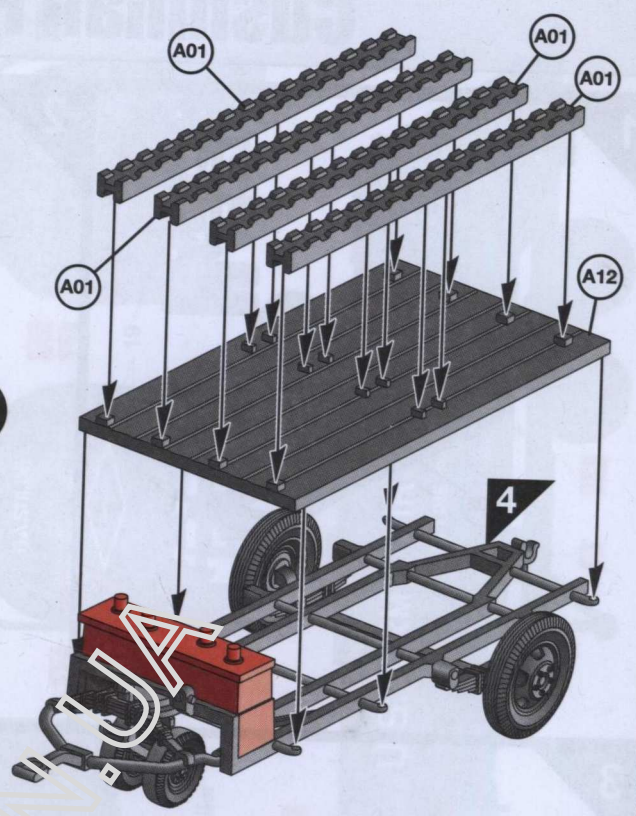
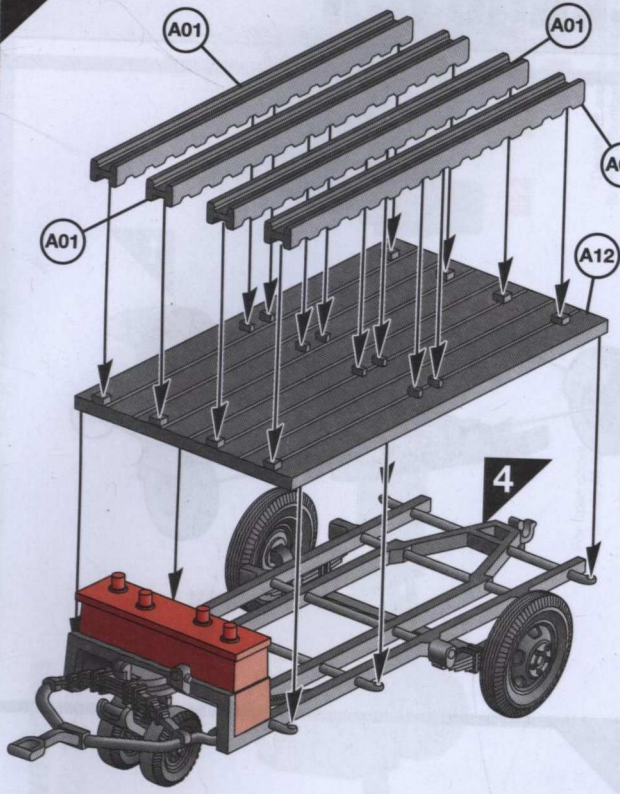

?

6

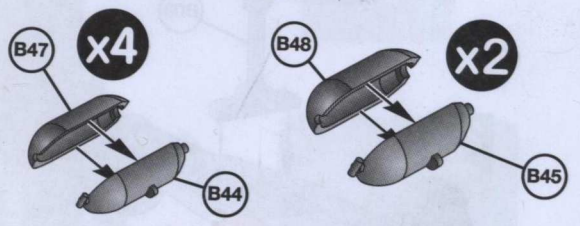
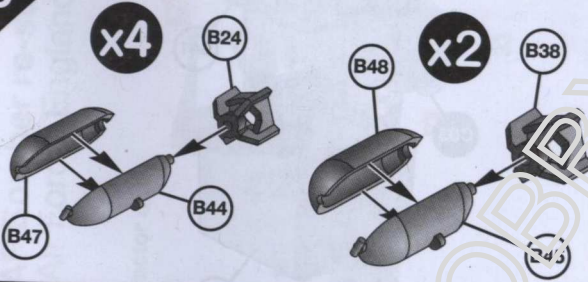

?

7

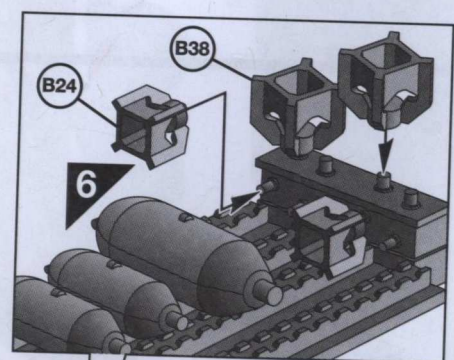
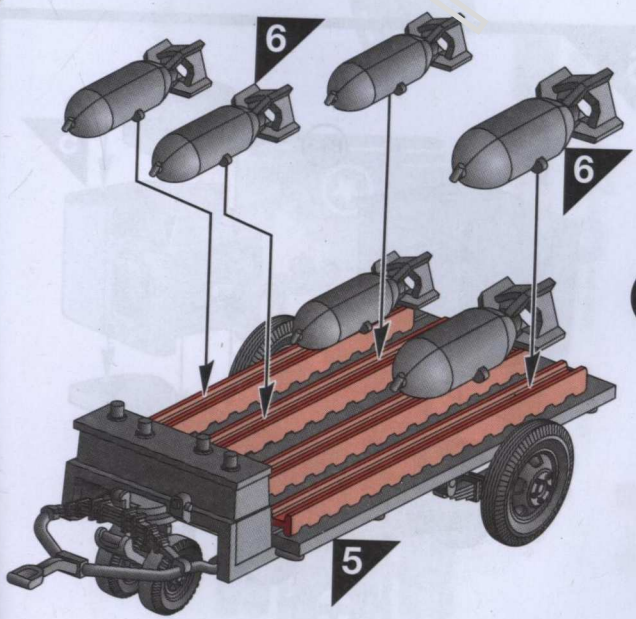

?

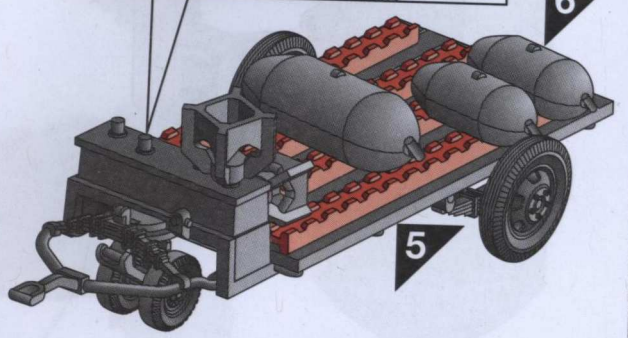

# Cushman Package Car

1

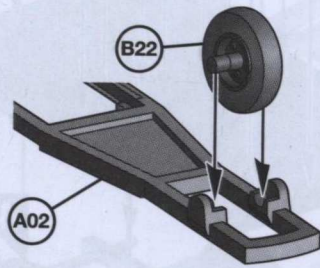

2

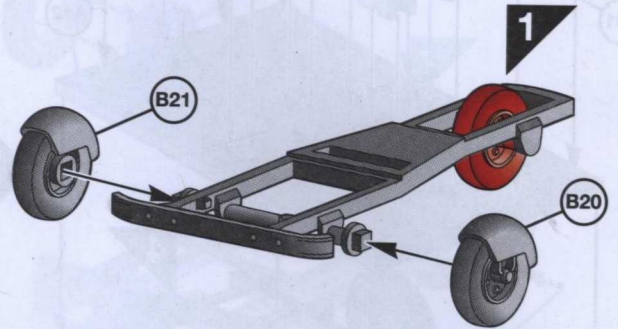

3

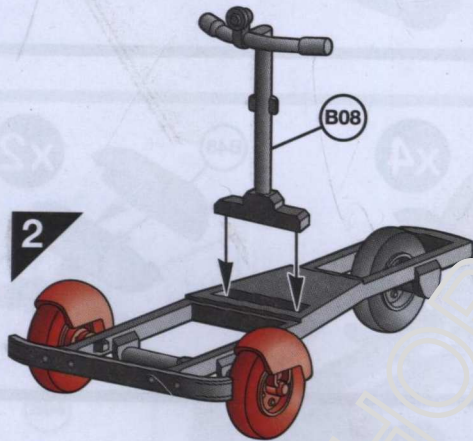

4

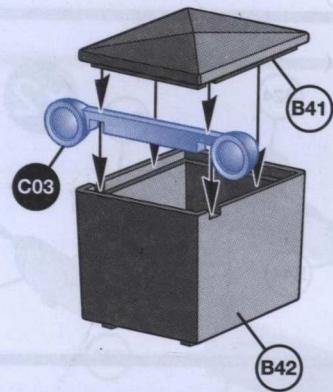

5

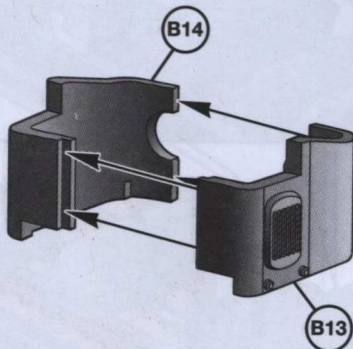

6

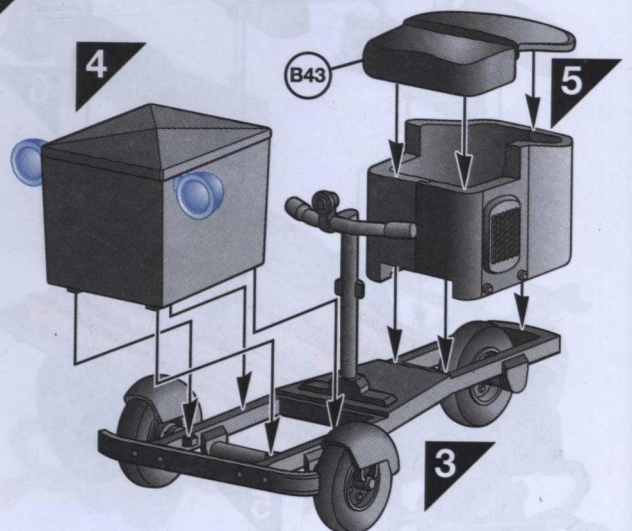

# USAAF Bomber re-supply vehicles 8th Air Force, England, 1942-1944

Autocar U-7144-T 4X4 tractor unit



155

10

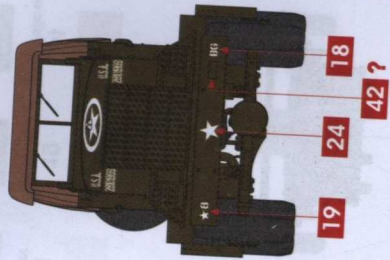
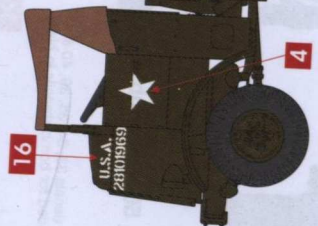
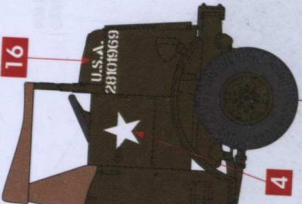
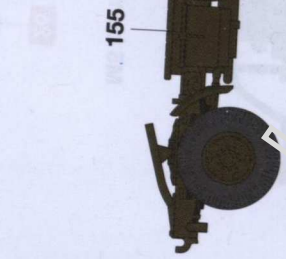
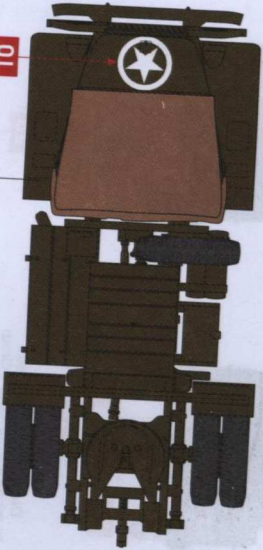

- 19 Gloss Red
- 33 Matt Black
- 72 Matt Khaki Drill
- 155 Matt Olive Drab

72

3

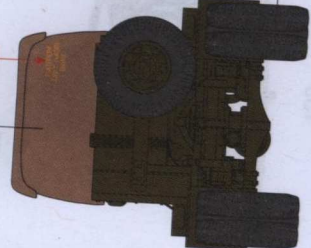

155



20

15

8

For open doors use decals 44 & 45

8



17

17

19

For open door, use decals 11, 12, 13

17

14



17

Decals 42 are provided to create Bombardment Group numbers, i.e. 92BG etc...

42 ?

19

24

18

155



20

F-1 fuel trailer

7



8

15



# USAAF Bomber re-supply vehicles 8th Air Force, England, 1942-1944

Cushman Model 39 Package Car

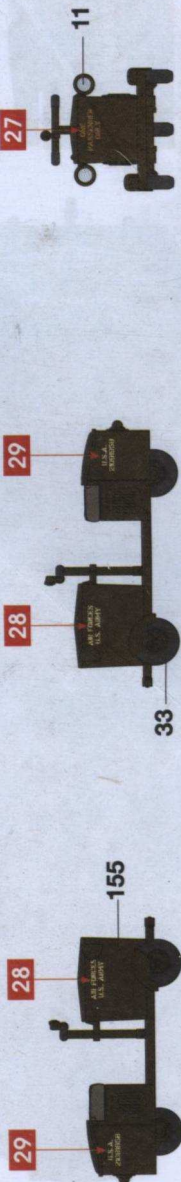

Chevrolet M6 bomb service truck



M5 bomb trailer

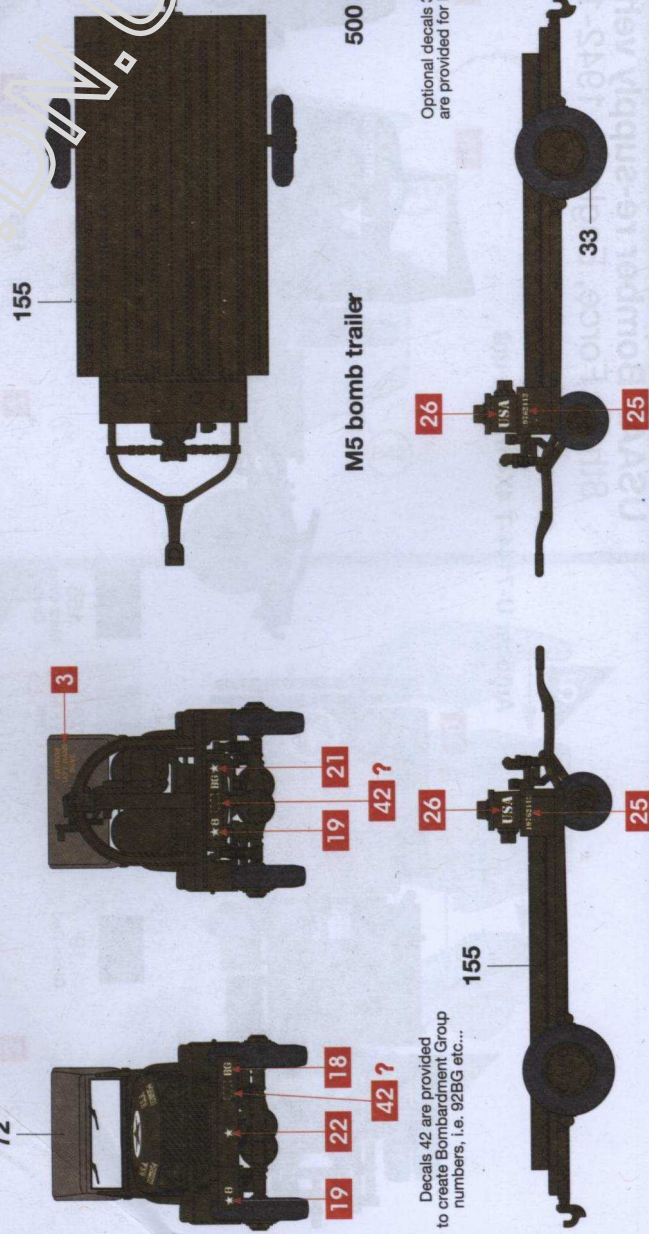

Decals 42 are provided to create Bombardment Group numbers, i.e. 92BG etc...

500 lb bomb

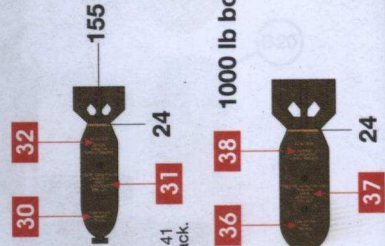

1000 lb bomb

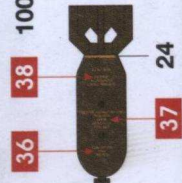

Optional decals 33, 34, 35, 39, 40 & 41 are provided for bomb stencils in black.

- 11 Silver
- 19 Gloss Red
- 24 Matt Yellow
- 33 Matt Black
- 72 Matt Khaki Drill
- 155 Matt Olive Drab

**B-17G Flying Fortress™**  
 Position of common stencil data

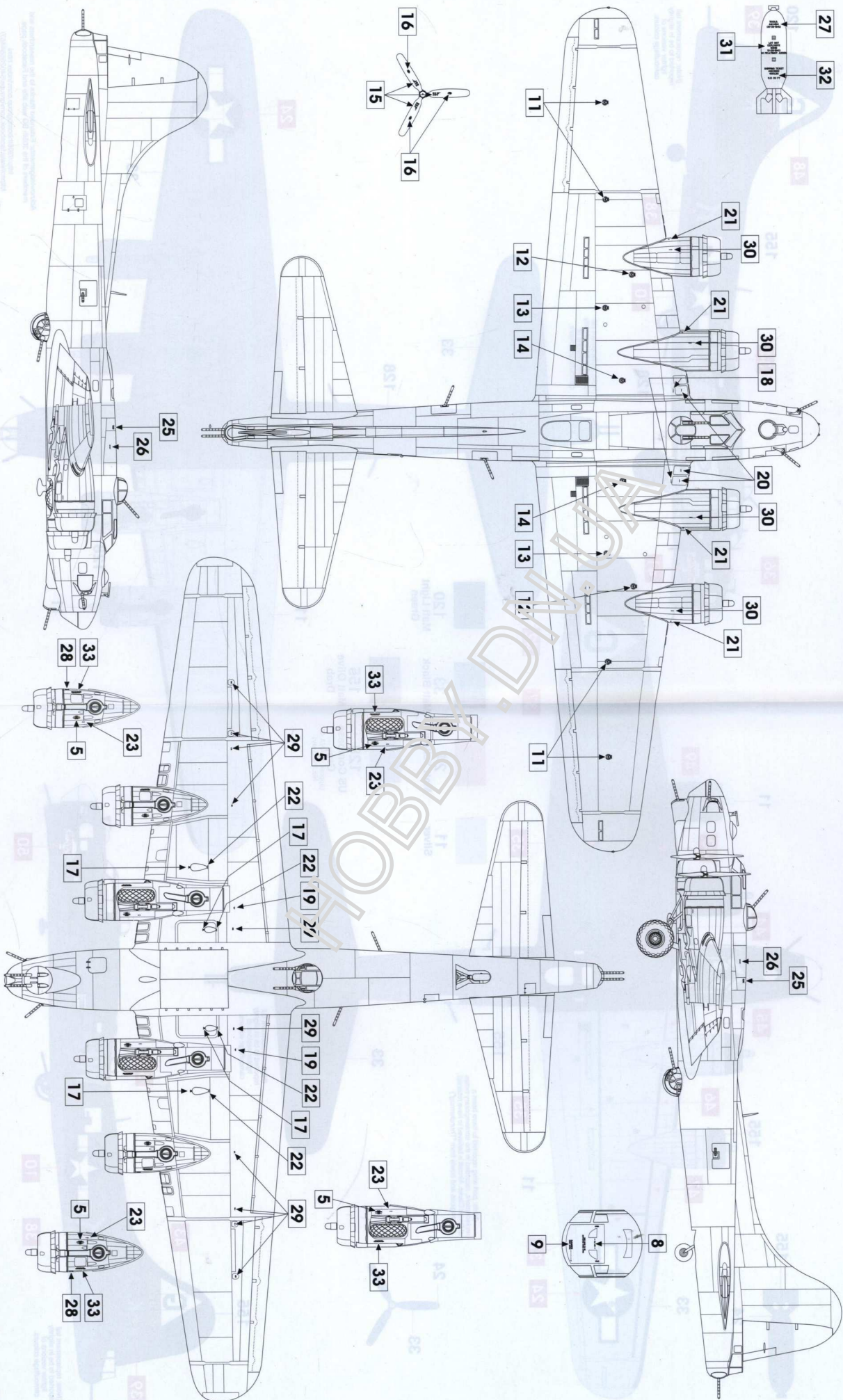

# Boeing (Douglas built) B-17G-35-DL Flying Fortress™

42-38206 "Thundermug", 364th Bomb Squadron, 305th Bombardment Group, Royal Air Force Chelveston, Northamptonshire, England, 1944.

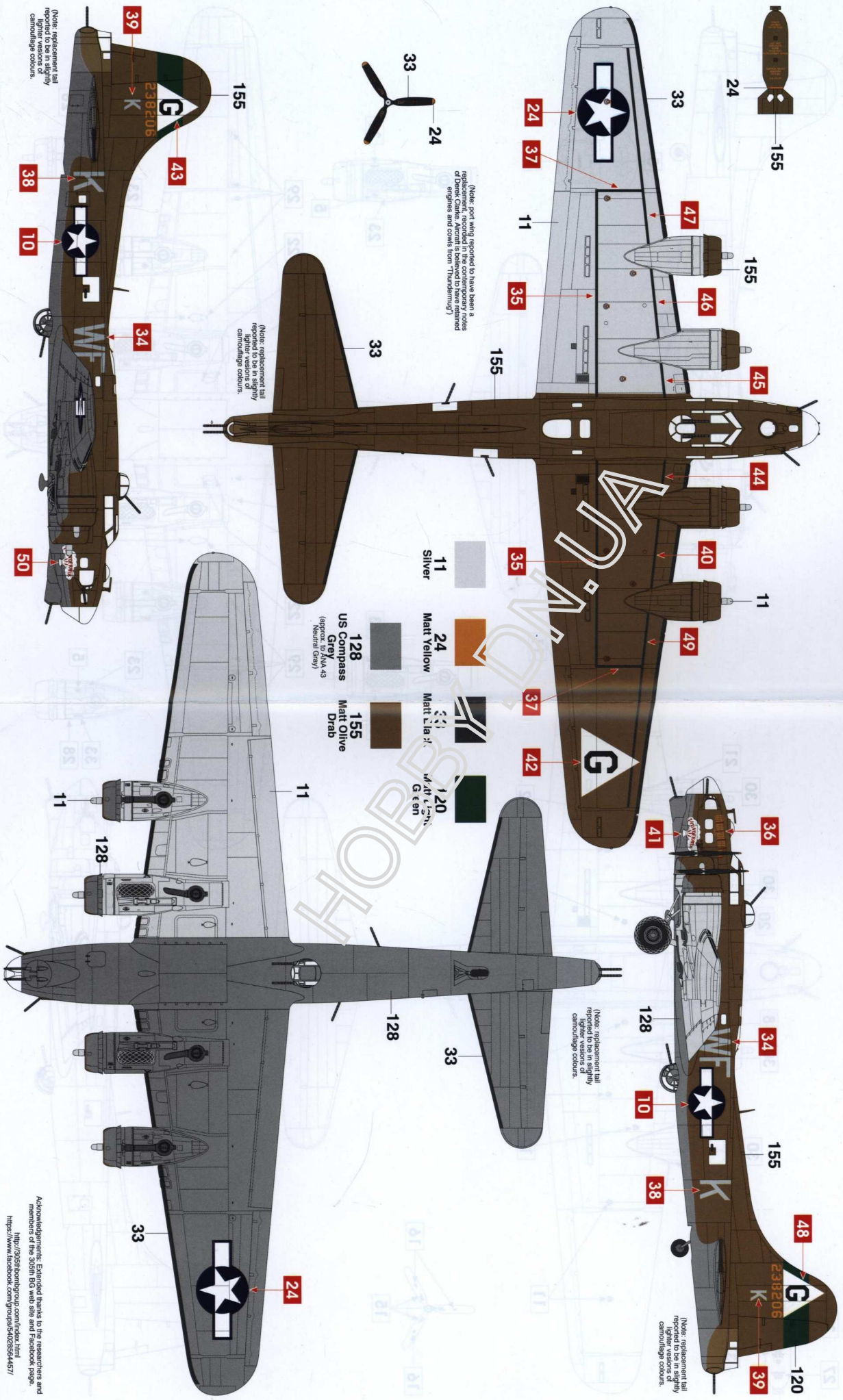

(Note: port wing reported to have been a replacement, recorded in the contemporary notes of Douglas (engines and cowls from "Thundermug")

(Note: replacement tail reported to be in slightly lighter versions of camouflage colours.

(Note: replacement tail reported to be in slightly lighter versions of camouflage colours.

(Note: replacement tail reported to be in slightly lighter versions of camouflage colours.