



Polikarpov I-153 Sturmovik

№ 48306

In the end of 1937 Nikolai Polikarpov began work on the further development of his I-15/I-15bis biplane fighter design.

The designer was guided at the moment only by his experience and the remarks of the combat pilots. His main objective was producing a mach light weight machine intended for a day time combat. The obsolete PV-1 machine guns were replaced with ShKAS with the rate of fire 1800 shots per minute.

With M-25V engine the flight weight of the fighter reached 4775 lb. the designer D. Tomashewitch developed retractable landing gear, that allowed plane's speed to reach up to 267 mph. The new airplane got I-153 name.

In June-August 1939 state acceptance trials were conducted using an I-153 powered by the new M-62 engine. These trials were not officially concluded until January 1940, long after the type had been superseded. Next in line was a version powered by the 900 hp M-63, and this version passed its trials on 30 September 1939.

The 800 hp M-62 was used in the largest number of aircraft,

around 3,000 in total. The 1,100 hp(at take-off) M-63 was used in 409 aircraft. A total of 3,400 I-153 were produced.

Soviet AF units deployed along the western border in June 1941 also had around 1300 I-153. With additional I-153s flown by 61st, 62nd, 66th, 74th, 241st 299ShAP (Sturmovoy AviaPolk - Attack Air Regiment) I-153s were also operated by the air forces at the Baltic, North and Black Sea Fleets. Other I-153s were operated by flying schools, units of the inland military districts and regiments based in the Far East, most of which would eventually go into action in the west.

The I-153 remained in use as a front line fighter until early in 1942, but by then very few aircraft were still intact, having been lost in the air on the ground and while acting as ground and while acting as ground attack aircraft. By the middle of 1943 the Red AF only had 36 I-153s on its strength.

A few remained in service in the Far East and North Sea Fleets as late as 1945.

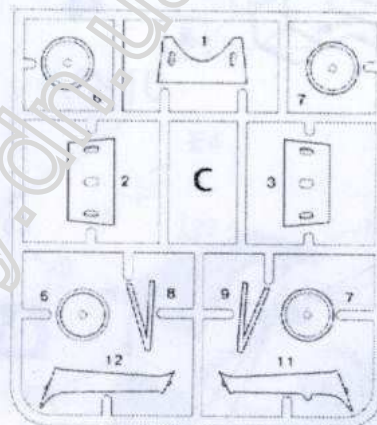
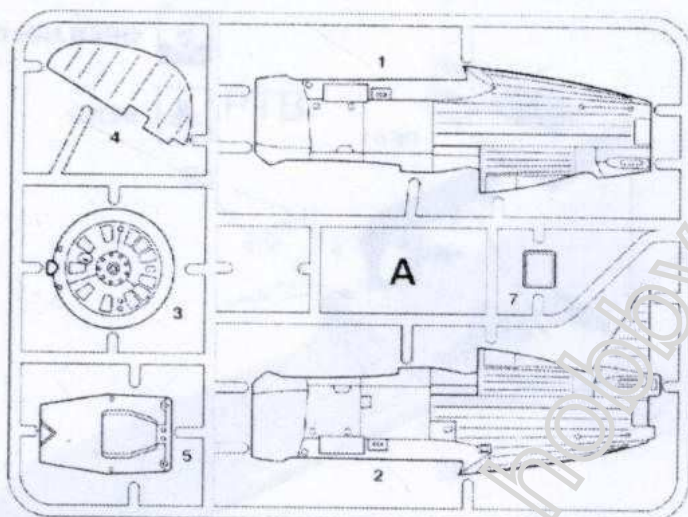

WIRE

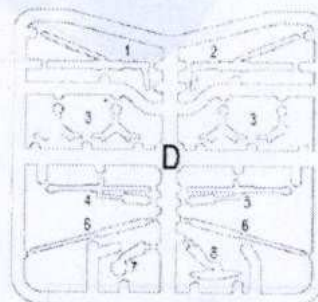
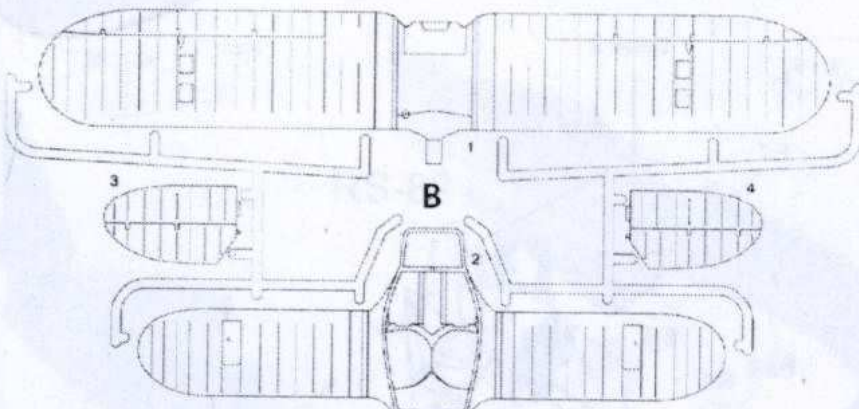

R1 0 0 0 0 0 0 0 0

R2

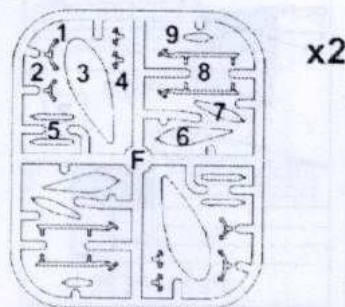
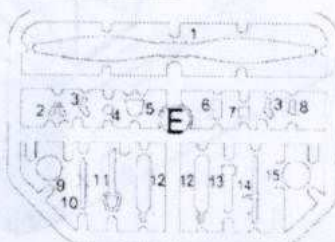

ASSEMBLY MANUAL

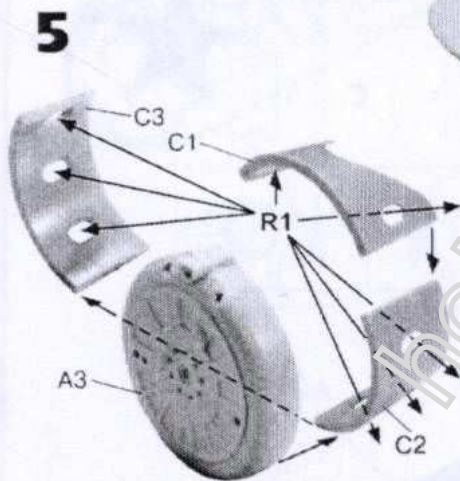
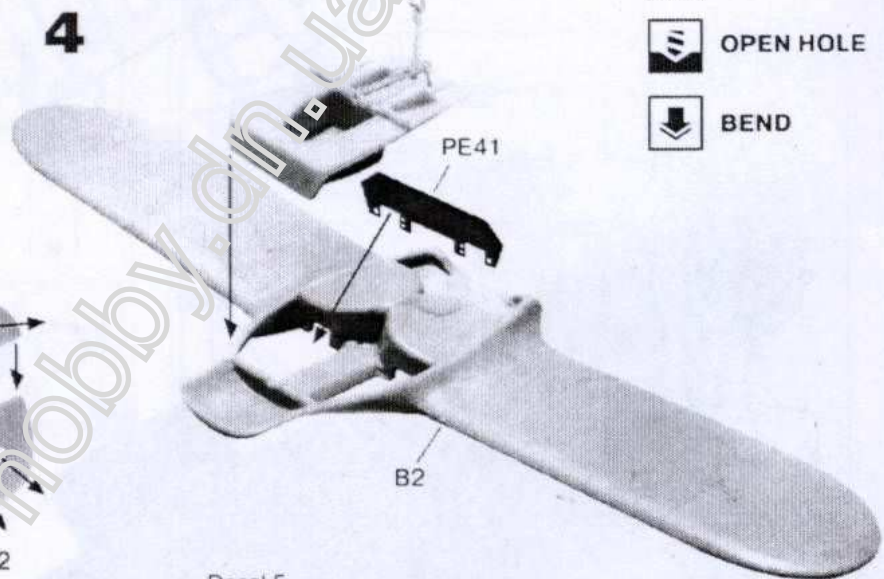
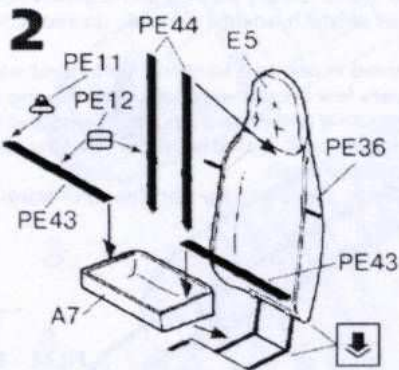
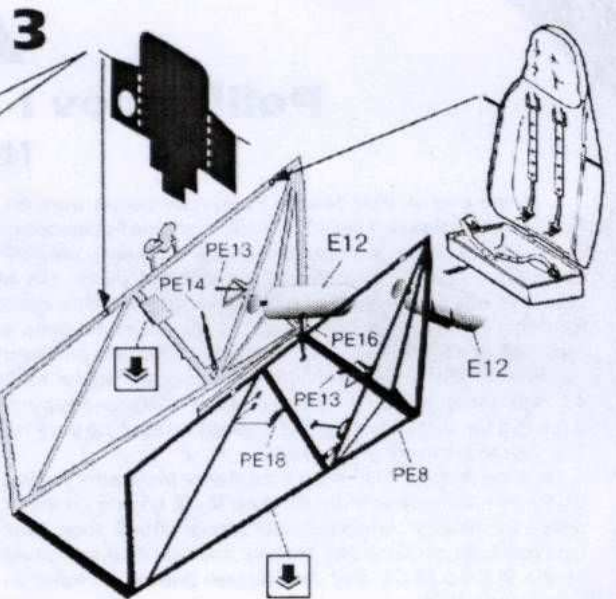
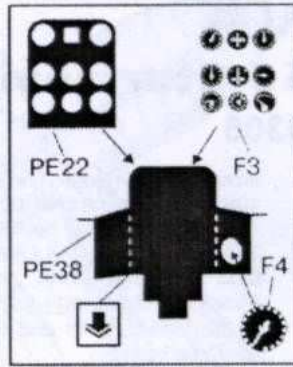
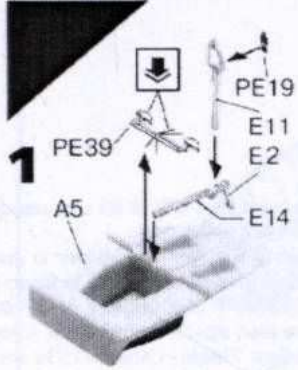

- OPTIONAL
- OPEN HOLE
- BEND

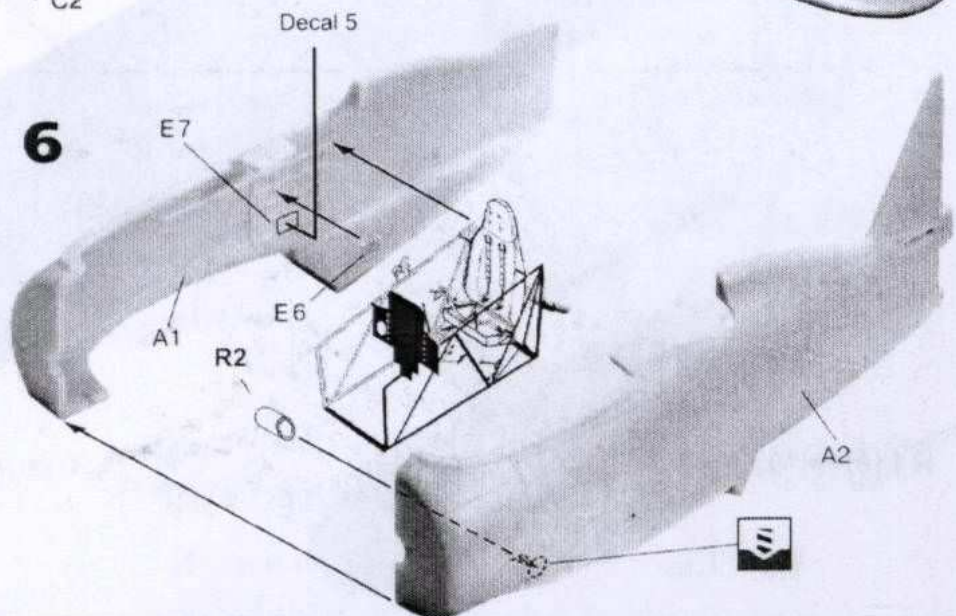
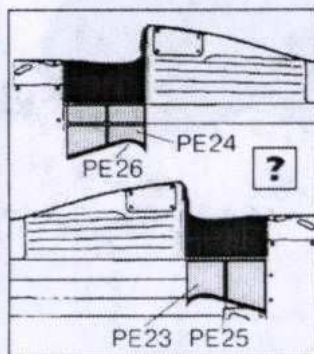

7

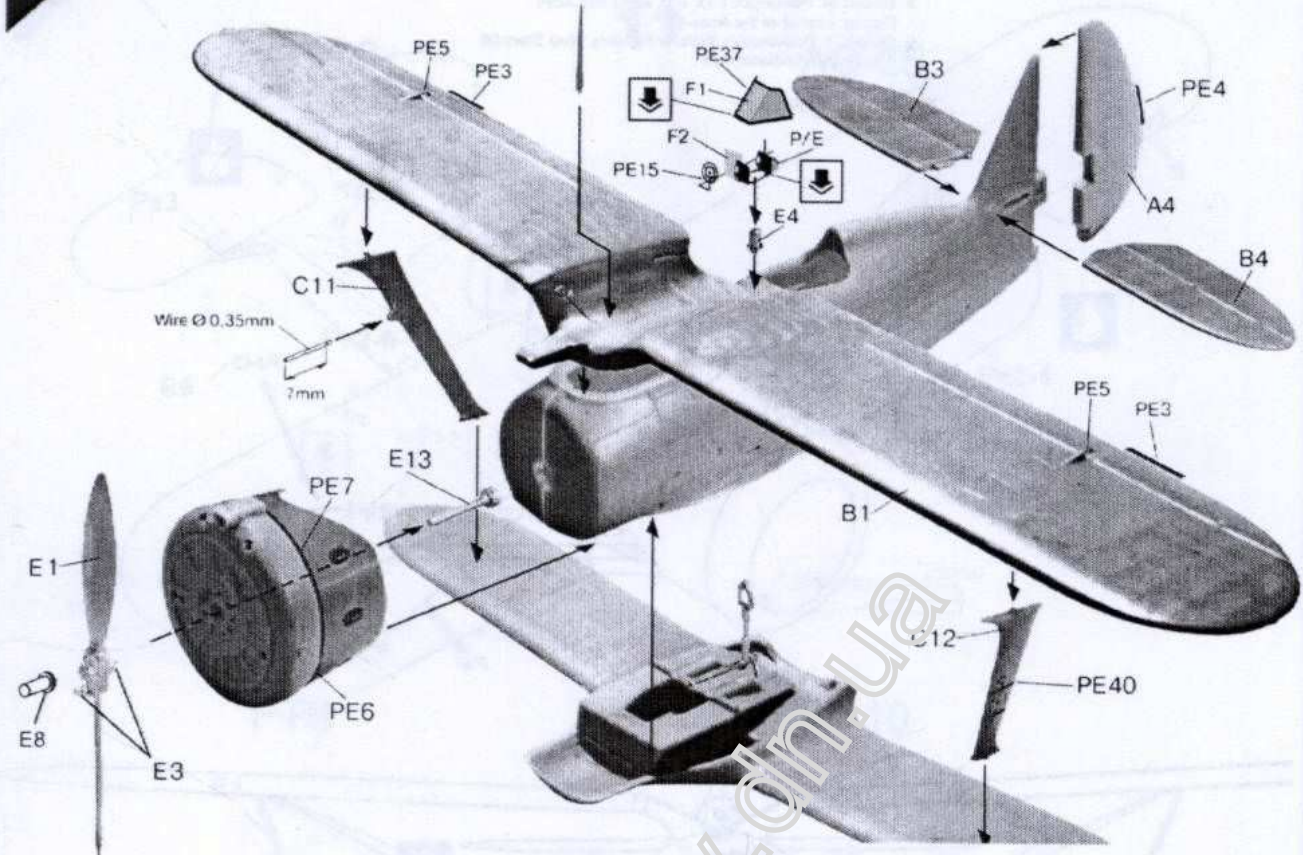

9

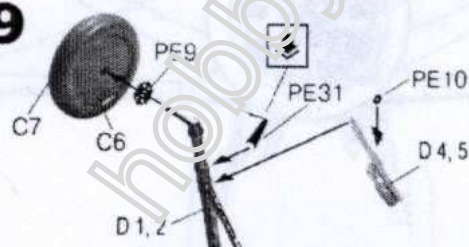

8

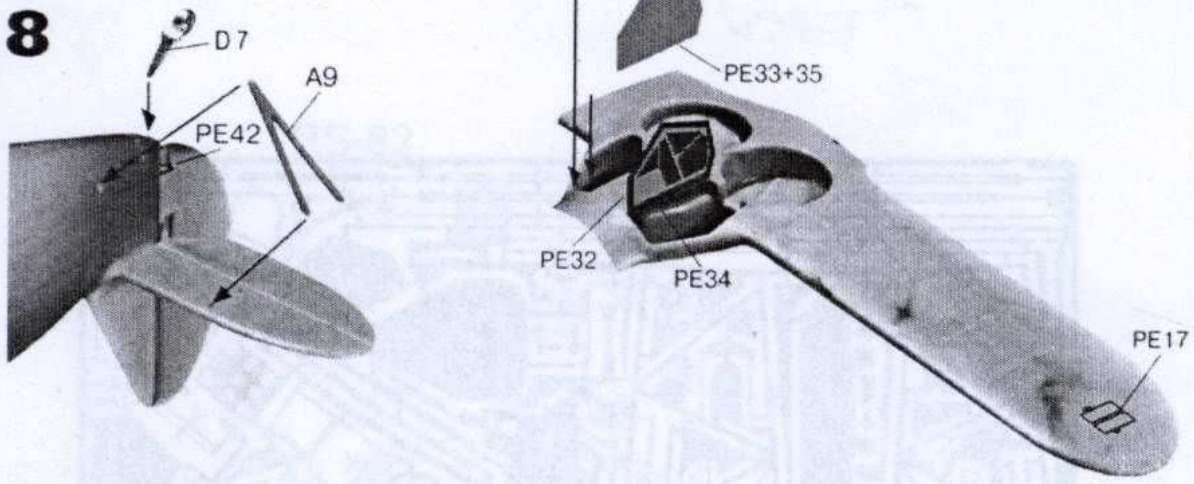

References:

- 1 Maslov M. I-153. Aviantic, 2001
- 2 Kowalski T. Samolot myśliwski I-153. TBIU 88
- 3 Aviation World Magazine 3/1993
- 4 Air Enthusiast Magazine 12
- 5 Maslov M. Polikarpov I-15, I-16 and I-153 Aces
Osprey Aircraft of the Aces-95
- 6 Gordon Y. Polikarpov's Biplane Fighters. Red Stars 06
J.K. Dexter. Midland Publ.

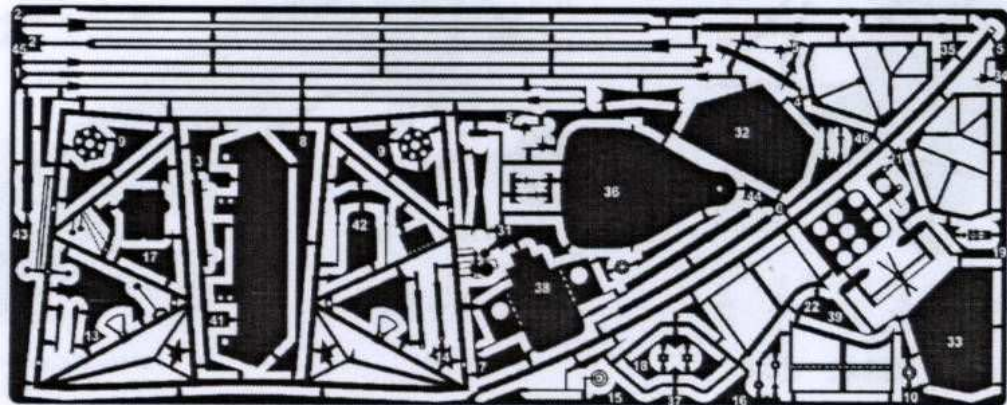
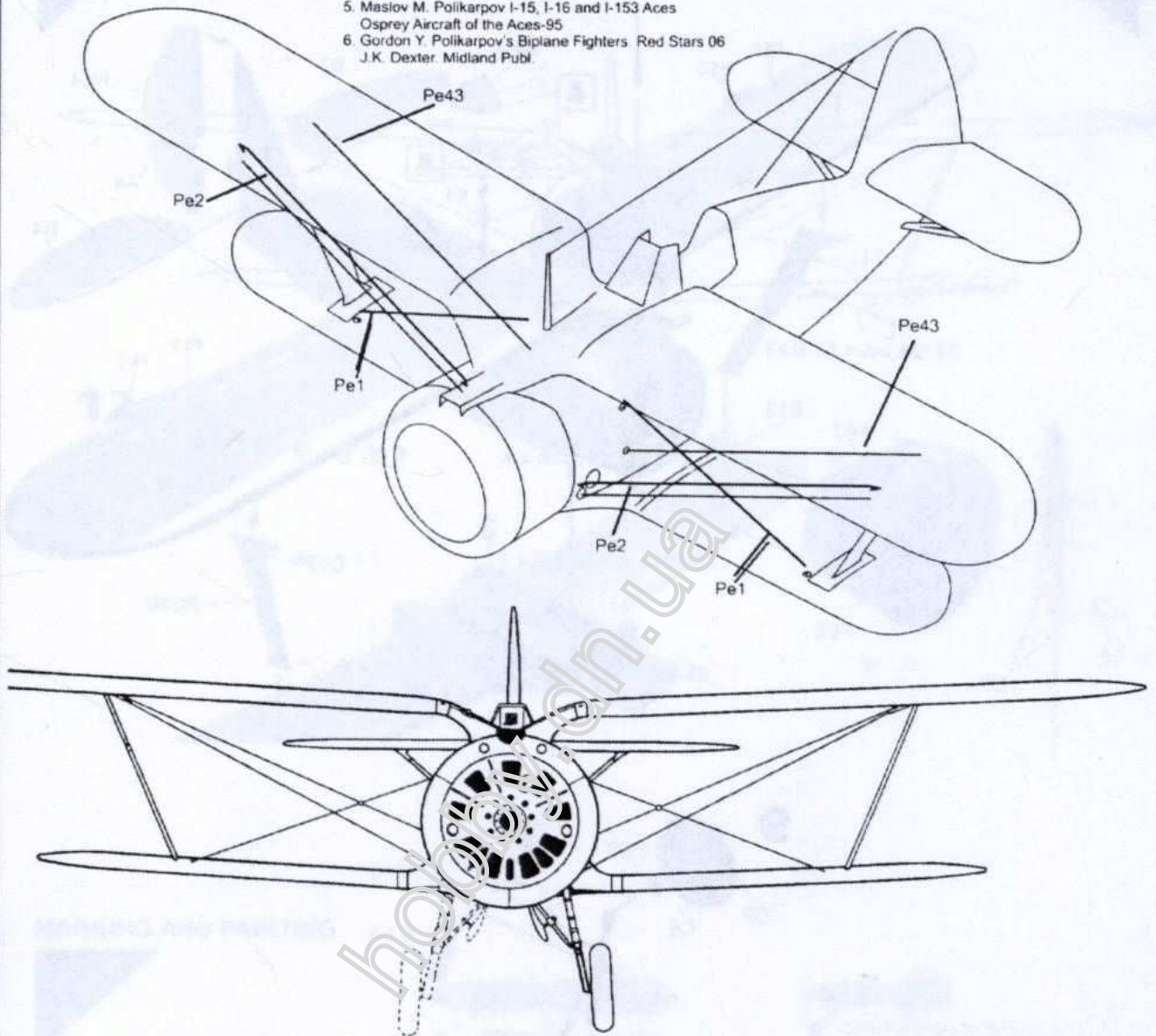

11

FAB-50

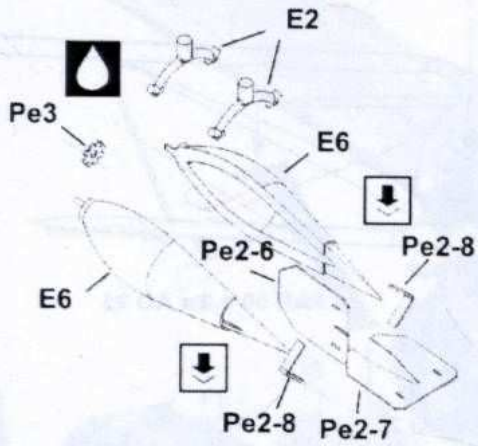

AO-25

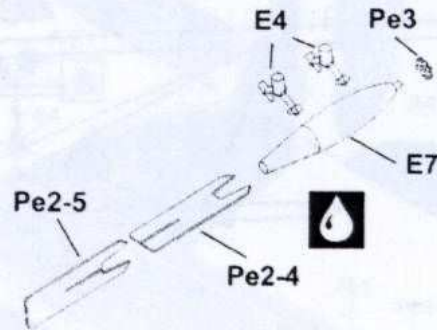

PTB

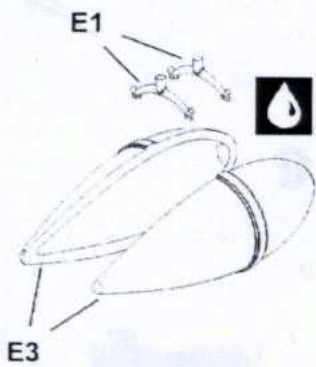

AO-10

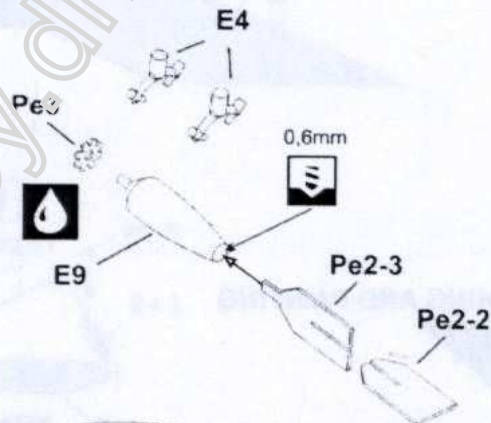

RS-82

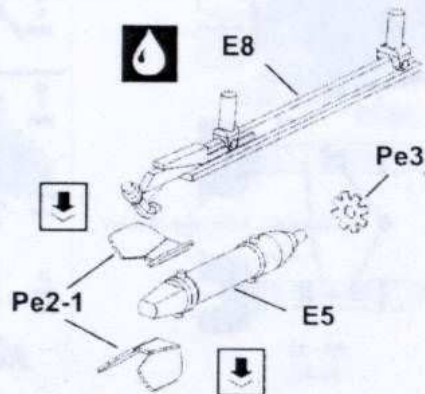

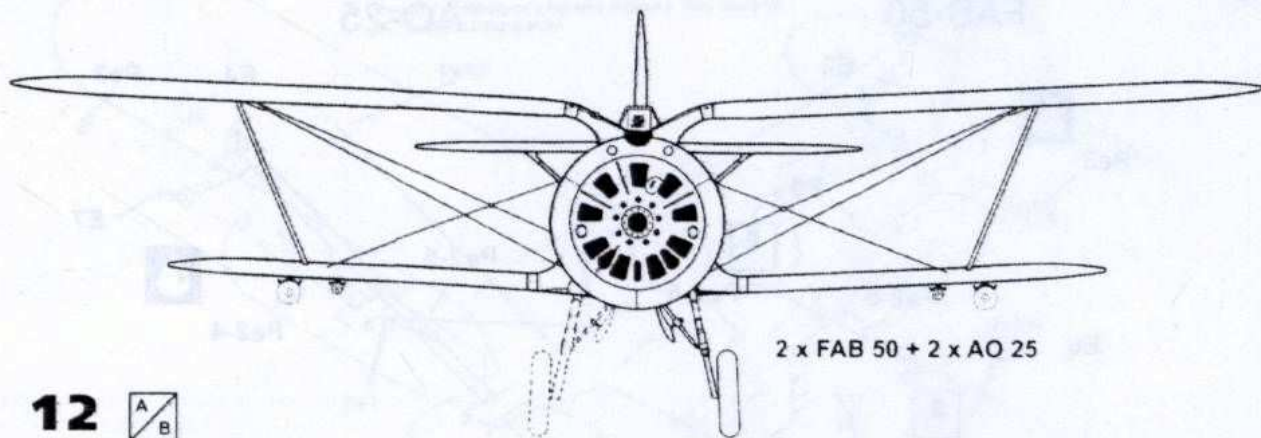

12

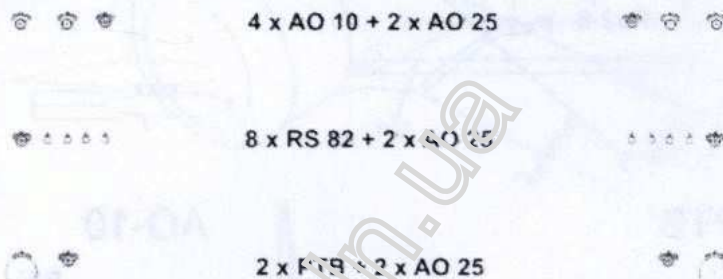

MARKING AND PAINTING

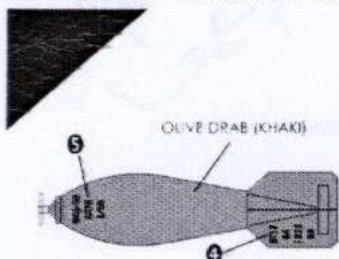

FAB-50sv. before 1941.
ФАБ-50св. до 1941 г.

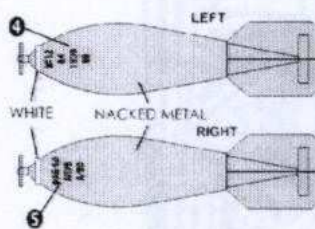

FAB-50sv. 1941-1945.
ФАБ-50св. 1941-1945 гг.

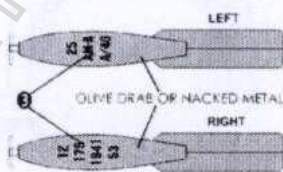

AO-25

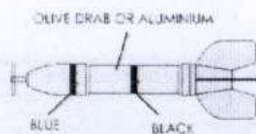

OLIVE DRAB OR ALUMINIUM

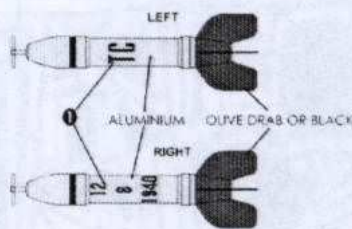

RS-82
PC-82

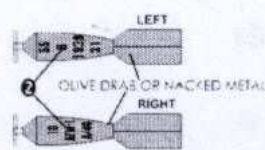

AOX-10

Decal weapons

12 8 1940	TC	12 8 1940	TC	12 8 1940	TC	12 8 1940	TC
0		0		0		0	
12 8 1940	TC	12 8 1940	TC	12 8 1940	TC	12 8 1940	TC
2		2		2		2	
10 8 A/W-1 A/40	55 8 1939 31	10 8 A/W-1 A/40	55 8 1939 31	10 8 A/W-1 A/40	55 8 1939 31	10 8 A/W-1 A/40	55 8 1939 31
25 A/W-1 A/40	12 175 1941 53	25 A/W-1 A/40	12 175 1941 53	№12 64 1939 99	№12 64 1939 99	№12 64 1939 99	№12 64 1939 99
3		3		4		5	
AMG		№48102		© 2013		№46 50 A/78 A/30	

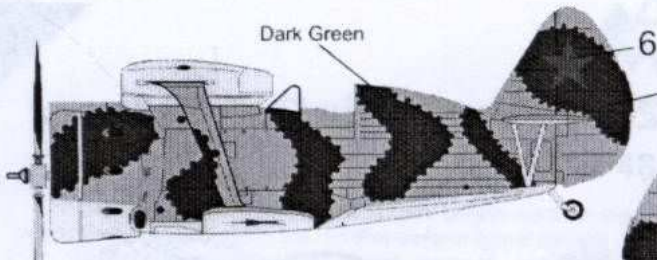

7 IAP(Fighter Regiment), Leningrad, 1941

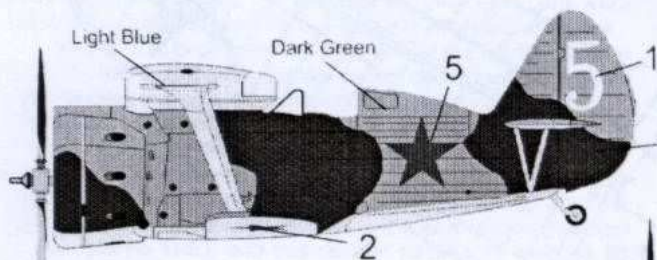
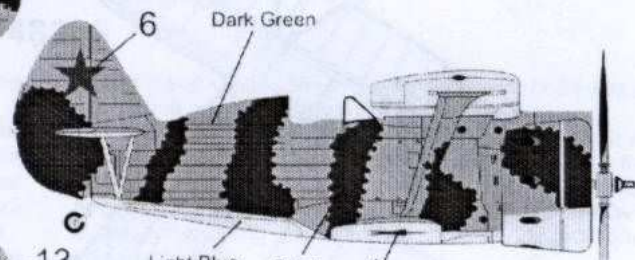

Nikolaev, South Front August 1941, Unit unknown

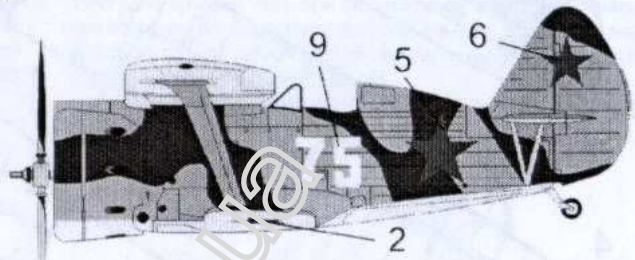

71 IAP, autumn, 1941, Leningrad

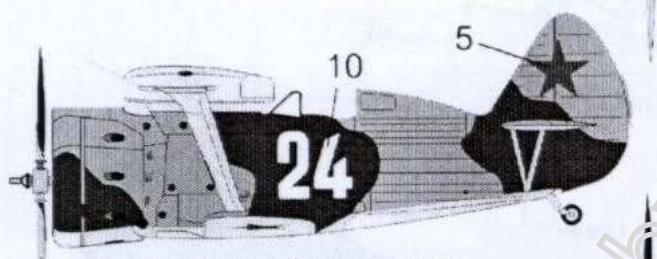

Capt K Soloviov(5+10 victories on I-153),
71 IAP, aug 1942, Laventzari

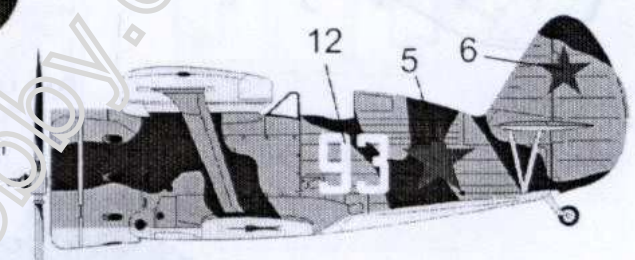

10 GIAP, 1942 Leningrad area

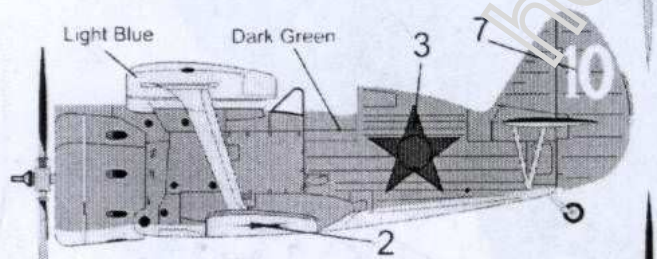

L-I L.Redko, Baltic Sea/ Sept 1941

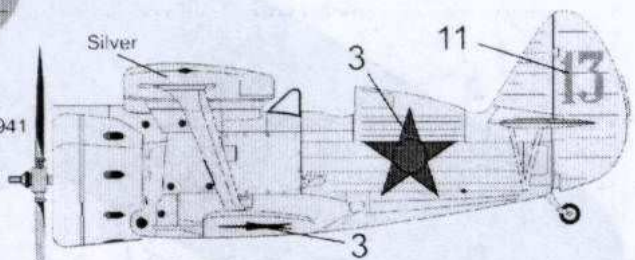

Jun.L-I G.Rechkalov, Moldavia, Sammer 1941

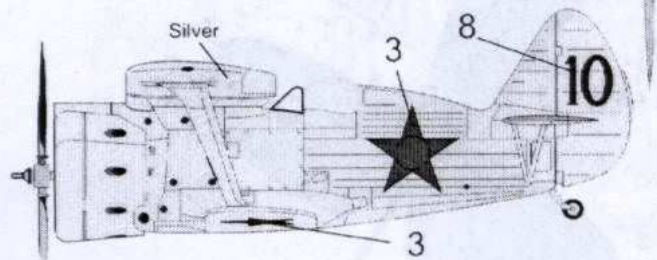

42 IAP (or) 132 IAP, Mogilev all

