

CAT.NO.BX72025 PLASTIC MODEL KIT LIMITED EDITION SCALE:1/72

- UA** Винищувач ІП-1 конструктора Д. П. Григор'єва виконав перший політ в січні 1935 року. Після ряду доробок літак запустили в серію. Випускався серійно до 1937 года на Харківському авіаційному заводі. Всього було випущено близько 200 екземплярів.
- GB** The IP-1 fighter designed by D.P.Grigorovich made its first flight in January 1935. After some developments the aircraft was put into serial production. The serial manufacturing of the IP-1 lasted until 1937 at Kharkov Aircraft Manufacturing Plant. A total of 200 aircrafts were built.

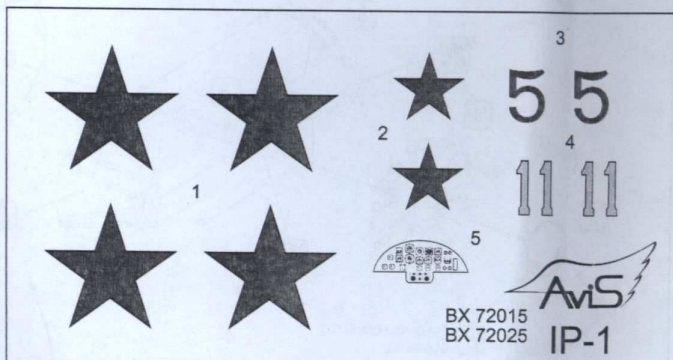

ДЕКАЛИ ДЛЯ ОДНОГО ВАРІАНТА
(Військово-повітряні сили СРСР)

DECALS FOR ONE VERSION
(Air Force USSR)



ДЕТАЛІ НЕ ВИКОРИСТОВУЮТЬСЯ
PARTS NOT USED

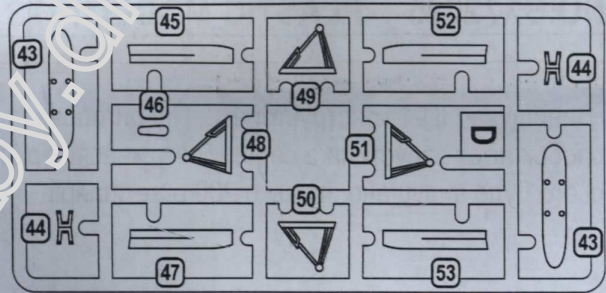
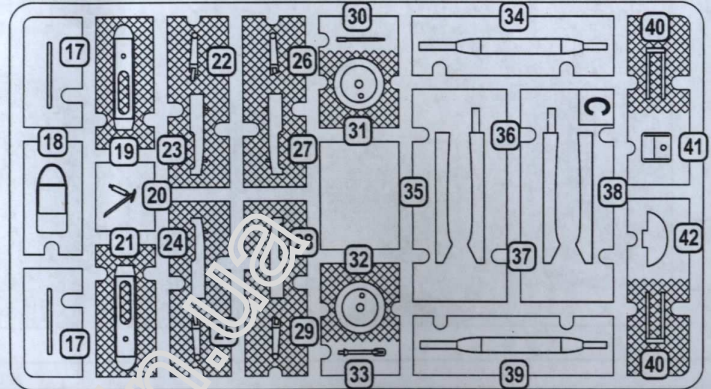
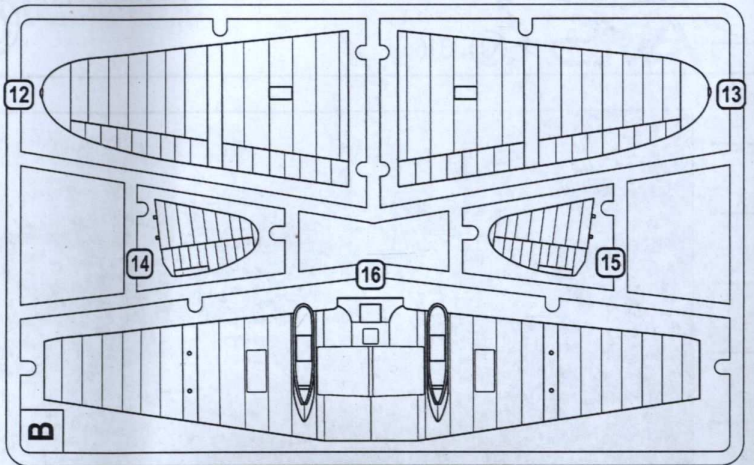
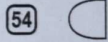
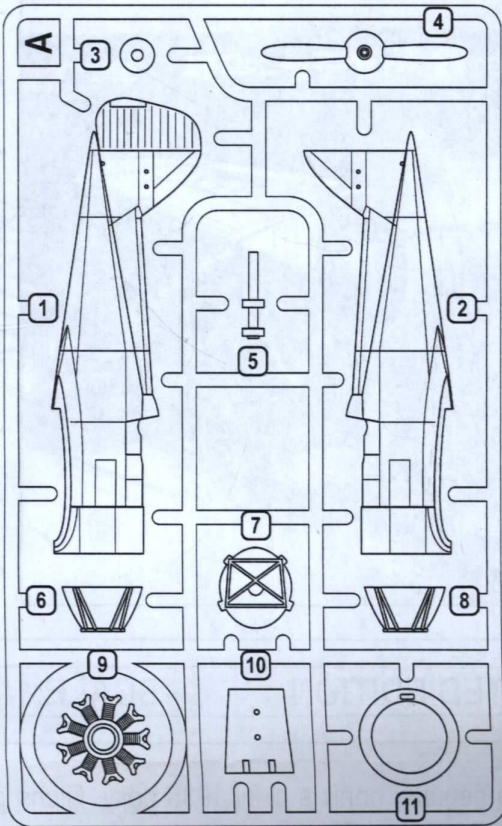

1 ЕТАПИ СКЛАДАННЯ
STAGES OF ASSEMBLY

1 НОМЕР ДЕТАЛІ
NUMBER PARTS



КЛЄЙТИ
GLUE



НЕ КЛЄЙТИ
DON'T GLUE

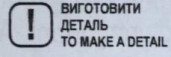

ВИГОТОВИТИ
ДЕТАЛЬ
TO MAKE A DETAIL

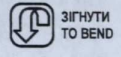

ЗІГНУТИ
TO BEND

2x КІЛЬКІСТЬ
ОПЕРАЦІЙ(ДЕТАЛЕЙ)
QUANTITY OF
OPERATIONS(PARTS)

A/B ФАРЕБУВАТИ
TO PAINT

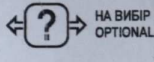

НА ВИБІР
OPTIONAL

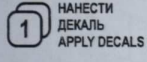

НАНЕСТИ
ДЕКАЛЬ
APPLY DECALS

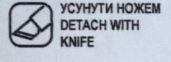

УСНУТИ НОЖЕМ
DETACH WITH
KNIFE

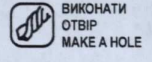

ВИКОНАТИ
ОТВІР
MAKE A HOLE

1 10 18 33 41

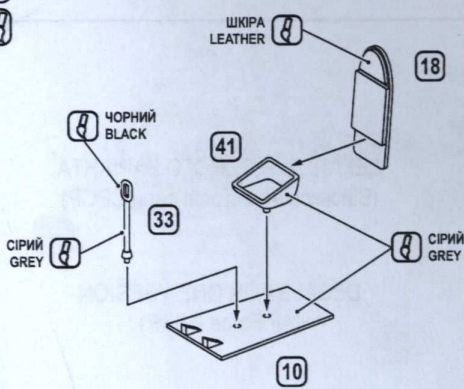

2 3 5 6 7 8 9

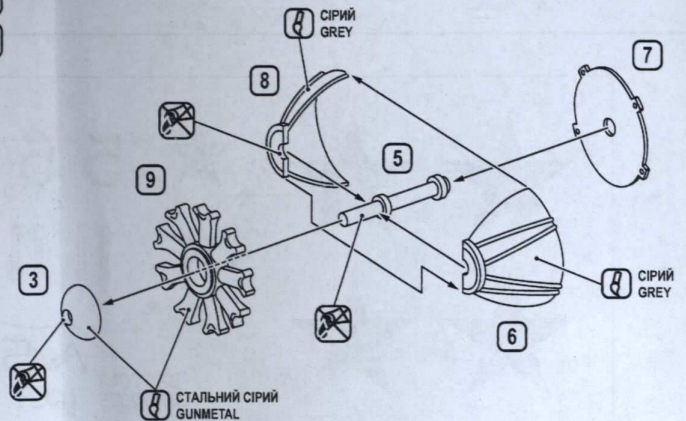

3 1 2 11 42 1 2

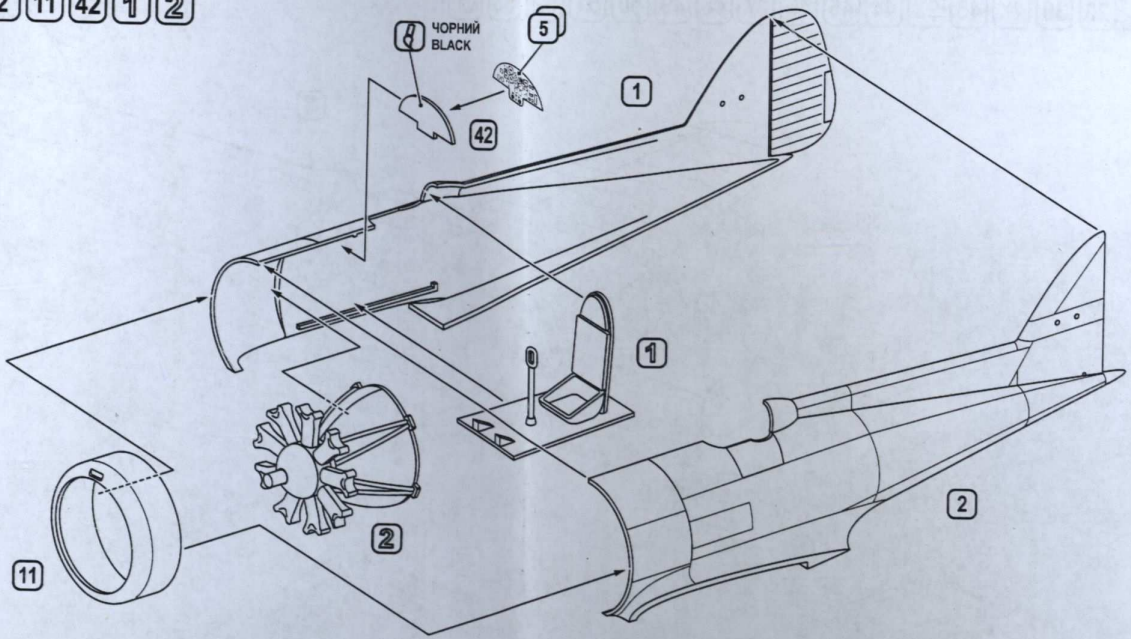

4 34 35 36

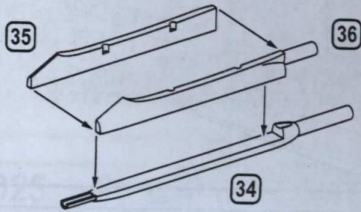

5 37 38 39

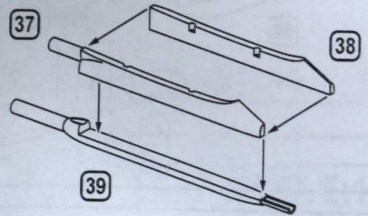

6 12 13 14 15 16 2X 17 54 3 4 5

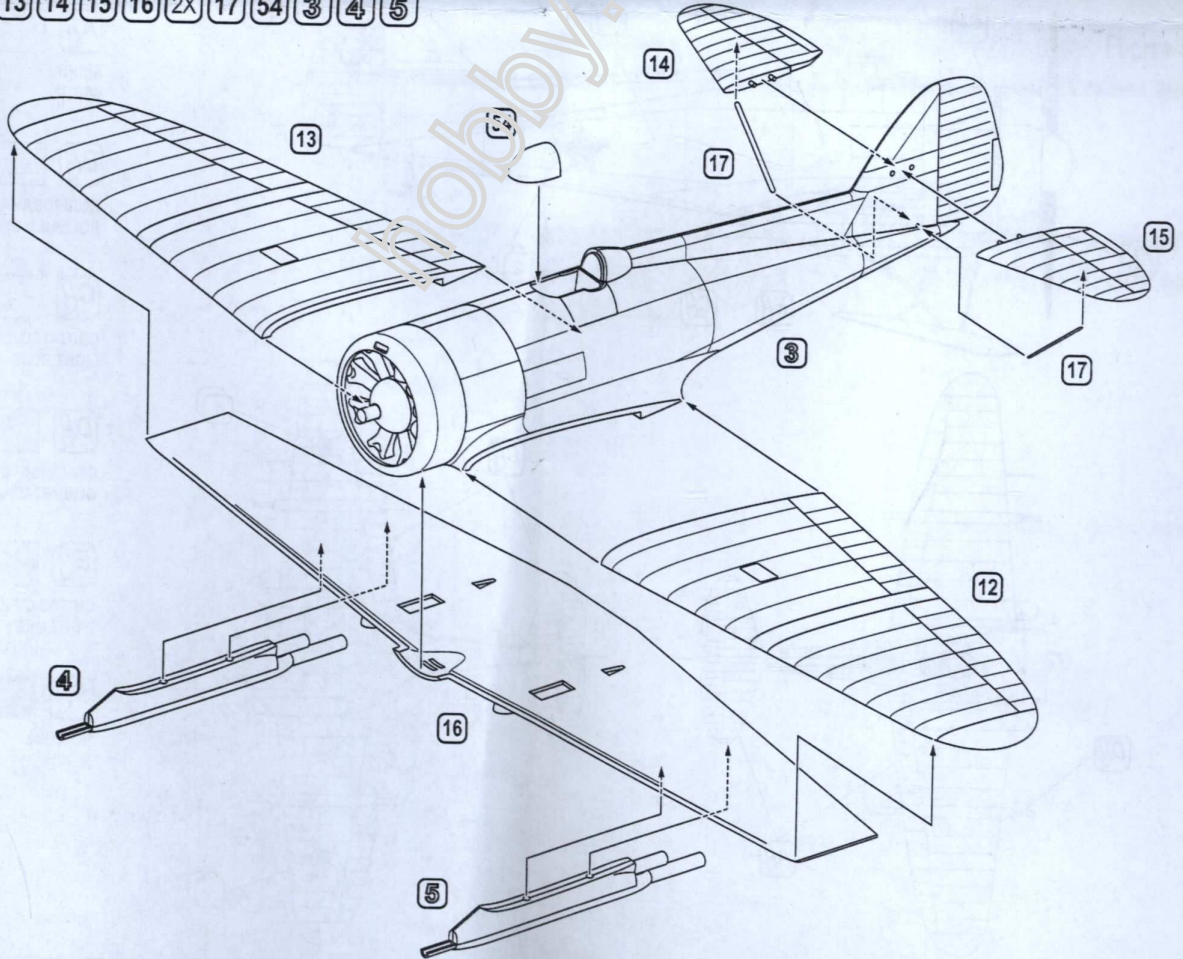

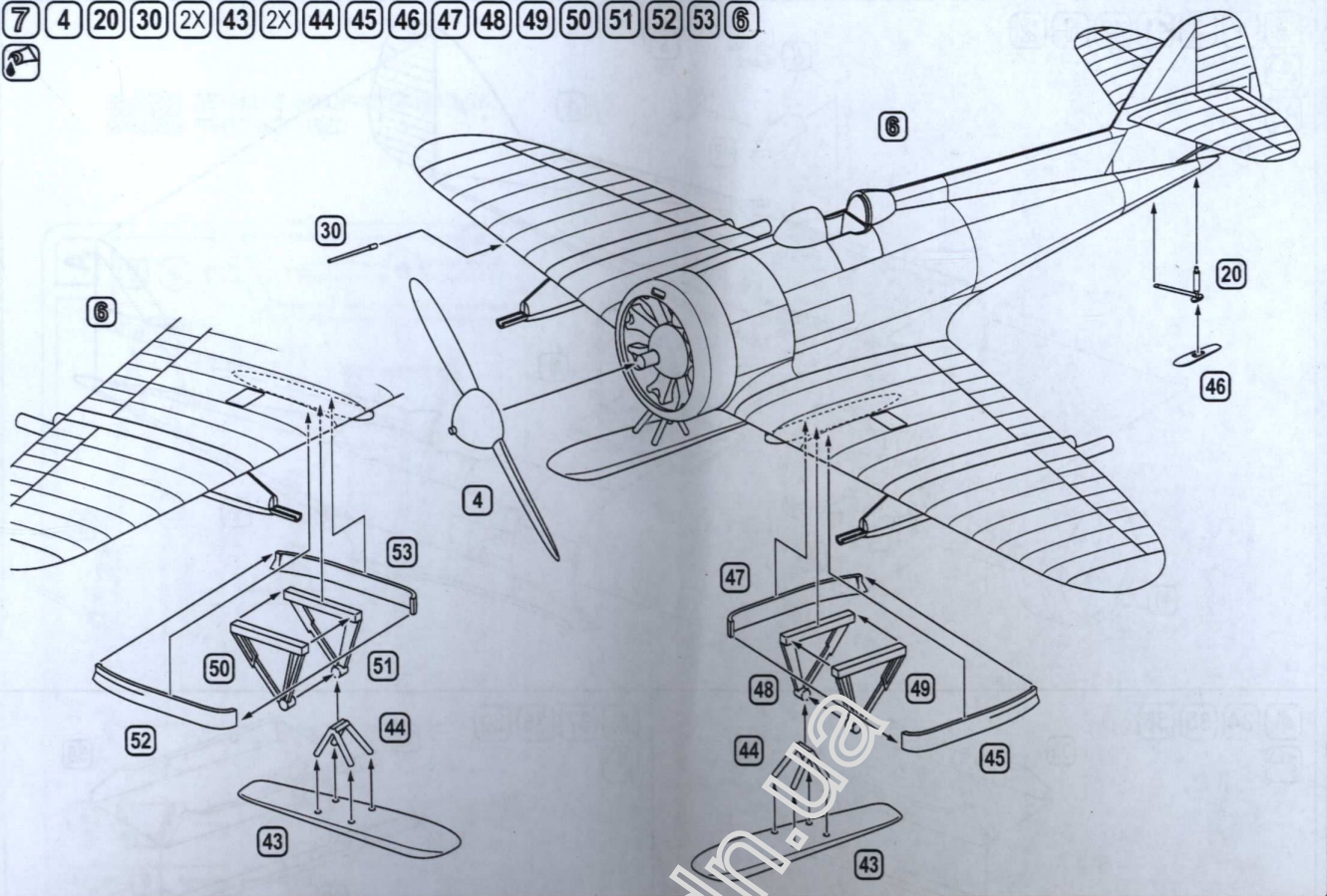

7 4 20 30 2X 43 2X 44 45 46 47 48 49 50 51 52 53 6

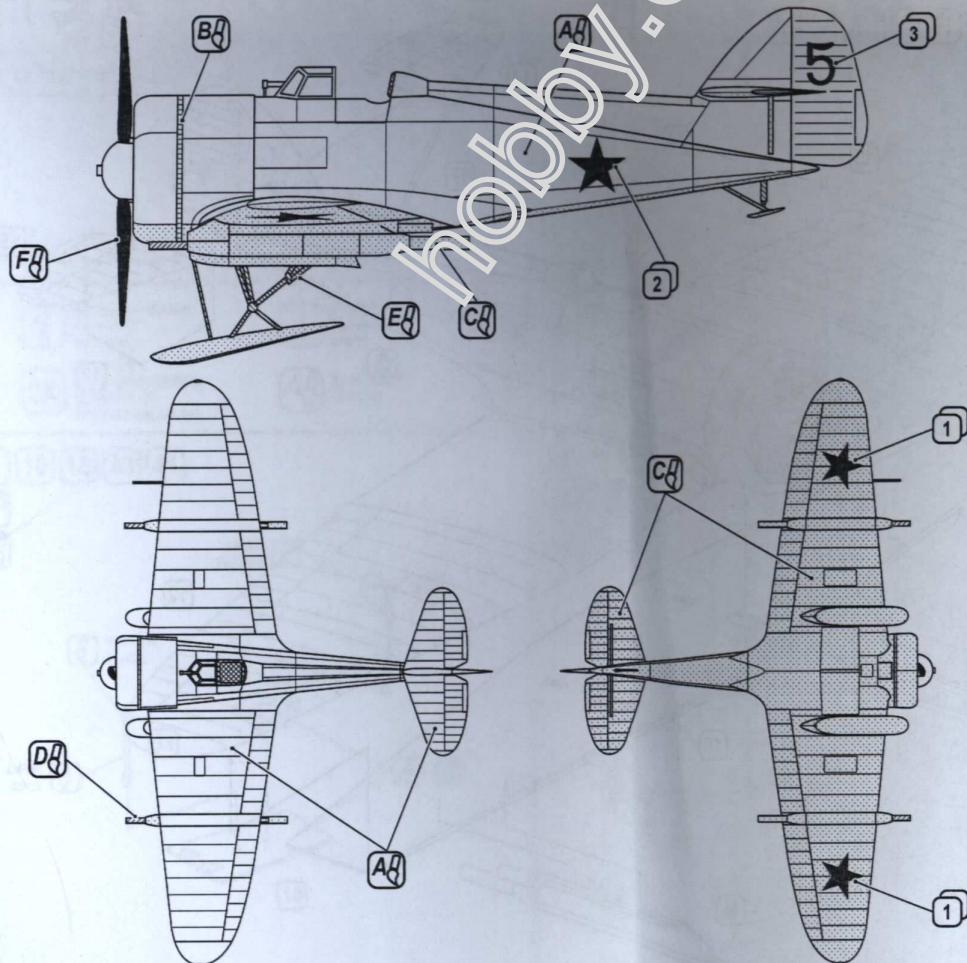

Grigorovich IP-1



AB 
 БІЛИЙ
 WHITE

BQ 
 ПОЛІРОВАНА СТАЛЬ
 POLISHED STEEL

CQ 
 СВІТЛО ГОЛУБИЙ
 LIGHT BLUE

DQ 
 СТАЛЬНИЙ СІРИЙ
 GUNMETAL

EQ 
 СВІТЛО СІРИЙ
 LIGHT GREY

FB 
 ЧОРНИЙ
 BLACK