

Tupolev Tu-134

Plastic model

scale :1/144

The Tupolev Tu-134 (NATO reporting name: Crusty) is a twin-engine airliner, similar to the American Douglas DC-9. The original version featured a glazed-nose design and, like certain other Russian airliners (including its sister model the Tu-154), it can operate from unpaved airfields. One of the most widely used aircraft in former Warsaw Pact countries, the number in active service is decreasing because of noise restrictions. The model has seen long-term service with some 42 countries, with some European airlines having scheduled as many as 12 daily takeoffs and landings per plane. In addition to regular passenger service, it has also been used in various air force, army and navy support roles; for pilot and navigator training; and for aviation research and test projects. In recent years, a number of Tu-134s have been converted for use as VIP transports and business jets. A total of 852 Tu-134s were built of all versions (including test bed examples) with Aeroflot as the largest user; by 1995, the Tu-134 had carried 360 million passengers for that airline.

Plastic part

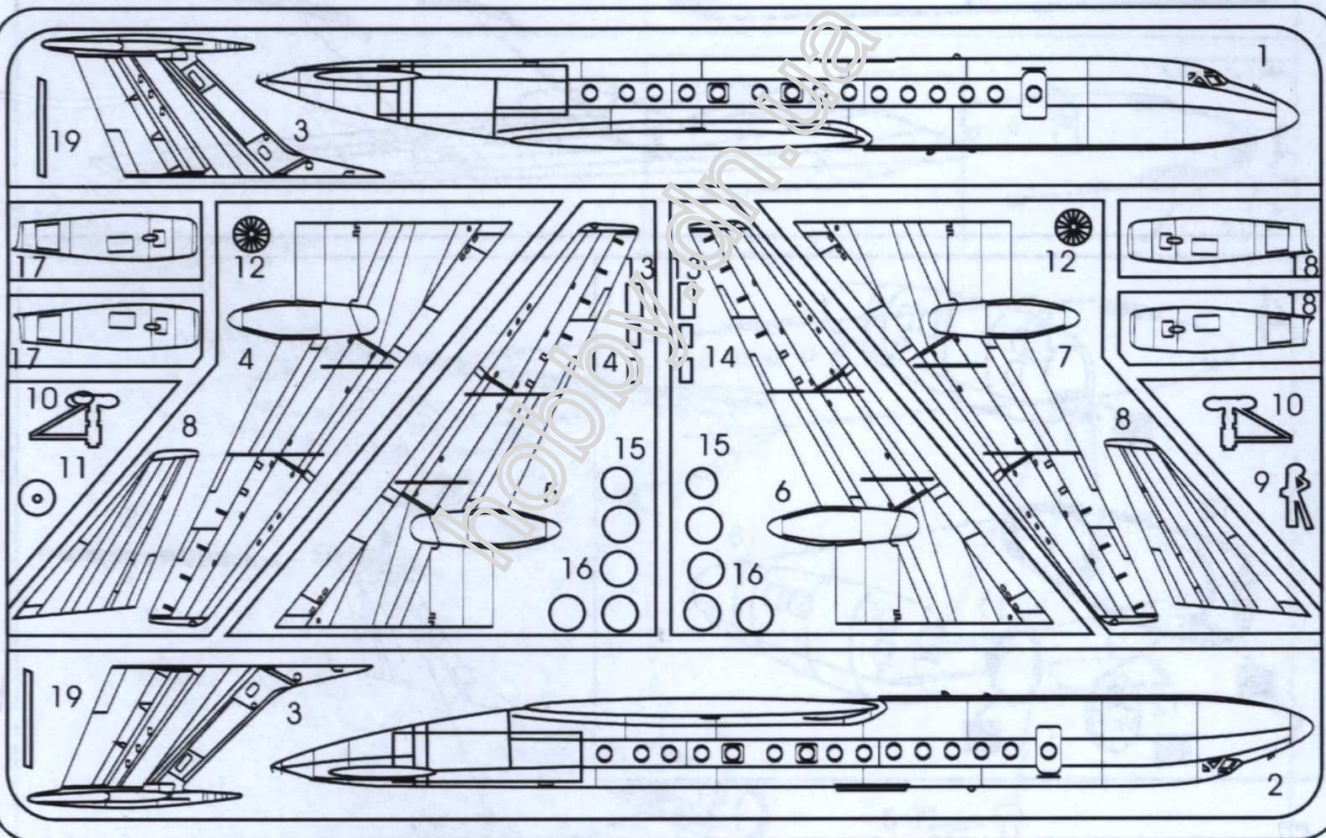

Decals



Photo-Etched parts

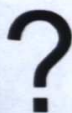

OPTIONAL
VOLBA



BEND
OHNOUT



OPEN HOLE
VYVRTAT OTVOR



SYMETRICAL ASSEMBLY
SYMETRICKÁ MONTÁŽ



A NOTH
ŽÁREZ



REMOVE
ODŘÍZNOUT

6

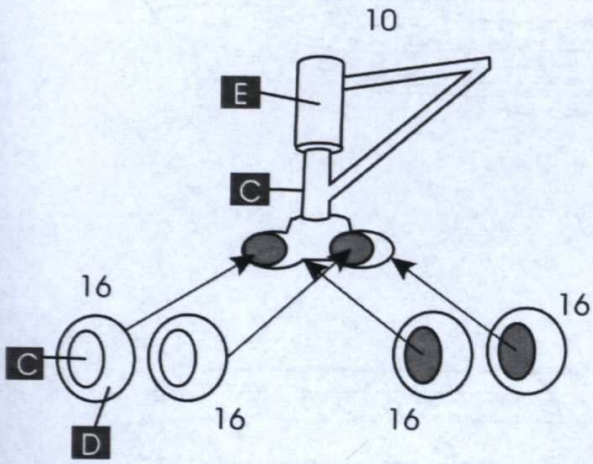

7

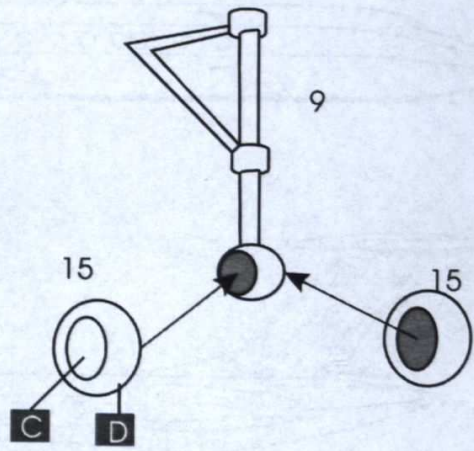

8

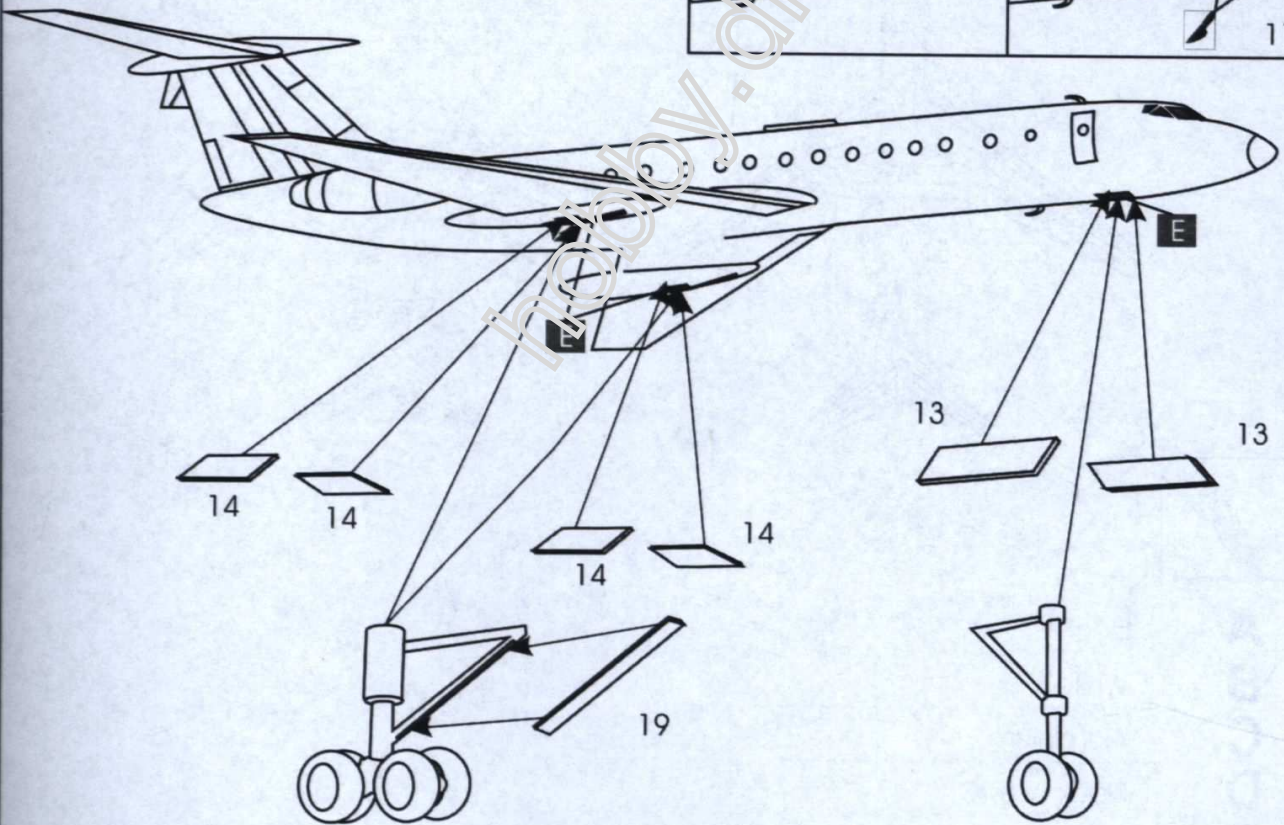

9

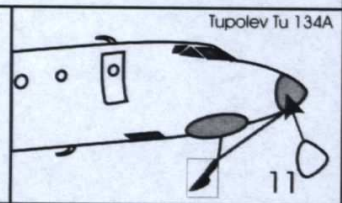
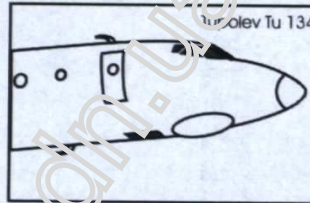

Tupolev Tu 134

Tupolev Tu 134A

11

Tupolev Tu-134

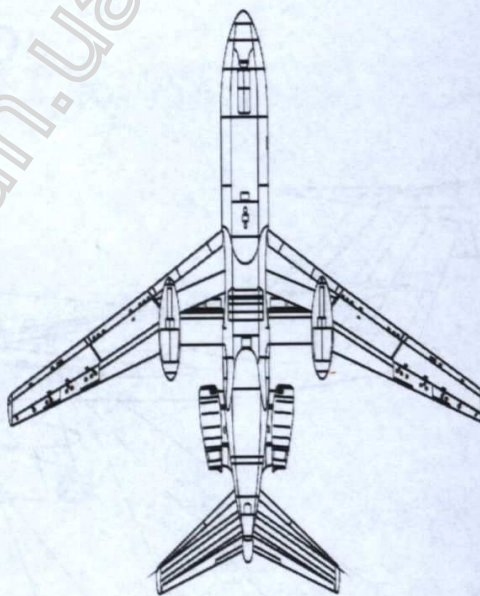
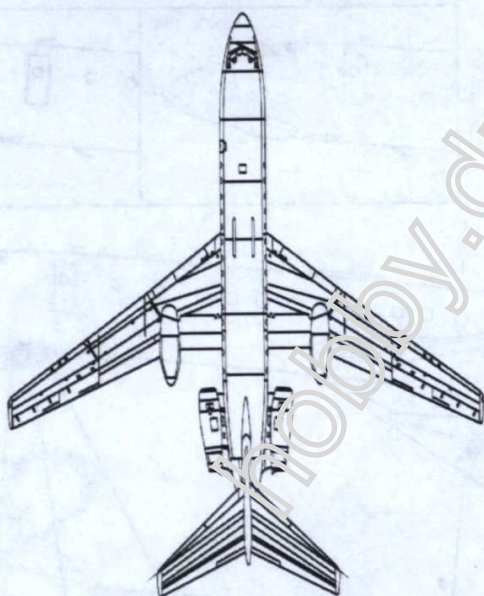
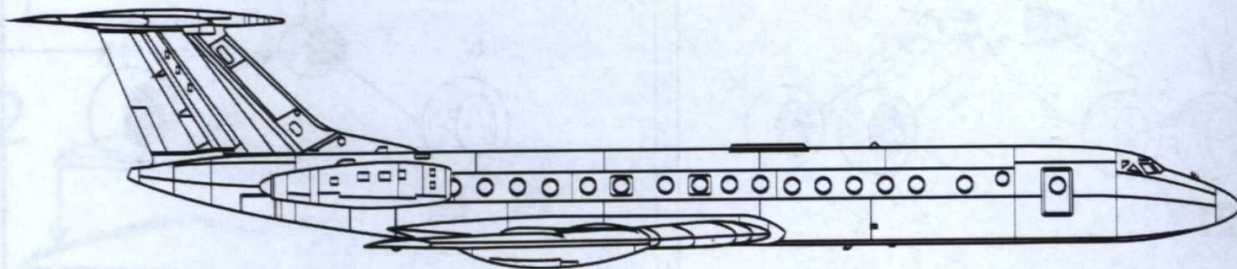
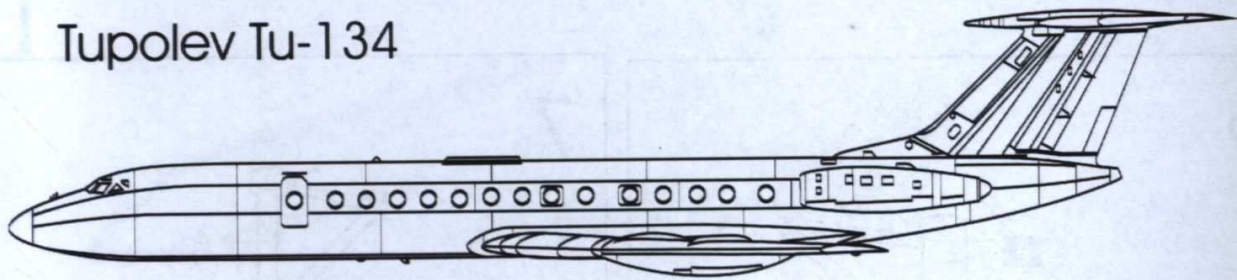

A	Black
B	White
C	Aluminium
D	Black Tyre
E	Light Grey
F	
G	
H	