

# Pitts Special S2 A/B

Plastic model  
scale 1/48

## History in brief

All single-seat (S-1) and two-seat (S-2) Pitts Specials are variations on the basic design from 1944. The aircraft was popularized by Betty Skelton, Caro Bayley and other air show performers, which led to the offering of plans around 1960.

Pitts produced limited numbers of aircraft during the 1940s and 1950s. It is widely accepted that the Pitts Special is the standard by which all other aerobatic aircraft are judged. After a number of home-built aircraft were produced from rough hand-drawn plans produced by Pitts, more professionally drawn plans went on sale in 1962. While many home-built aircraft were built in the 1960s, earning the Special a reputation as an excellent aerobatic aircraft, Pitts worked on the design of a two-seat aerobatic trainer version, the S-2, which first flew in 1967 and gained its type certificate in 1971. Factory-built aircraft produced by the Aerotek company at Afton, Wyoming were joined in production by the single-seat S-1S in 1973.

## Plastic parts/Plastikové díly

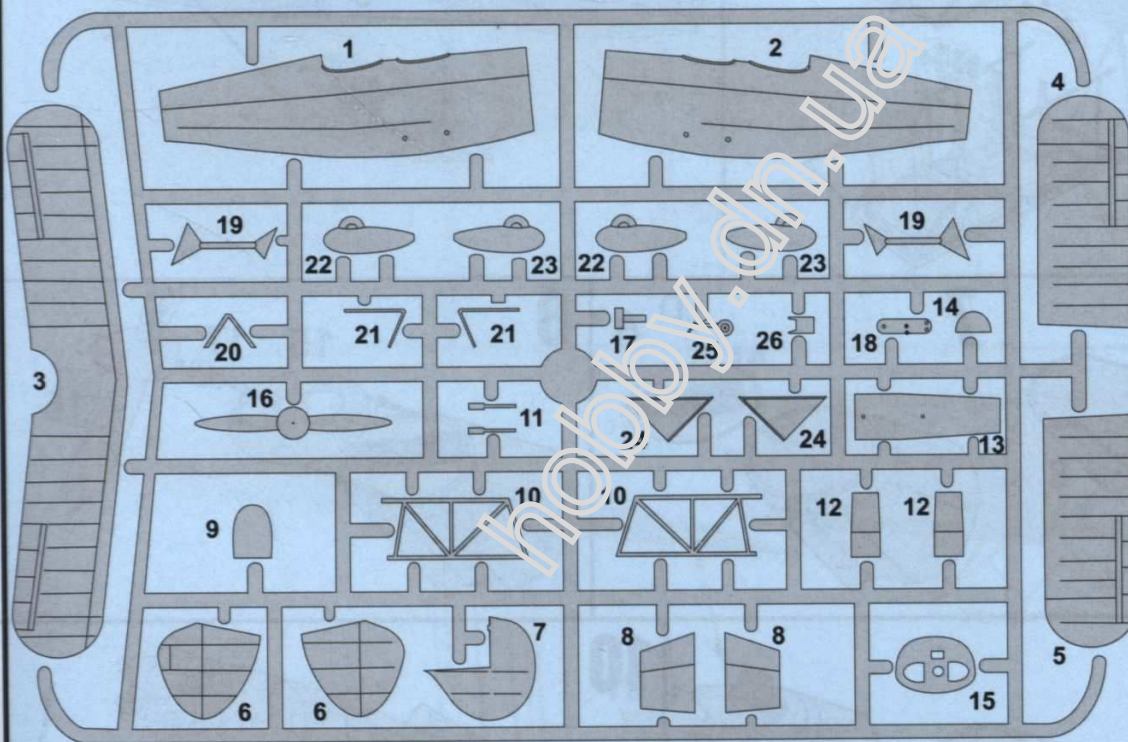

### Pro všechny verze, For all version

#### Kovové díly/ Metal parts

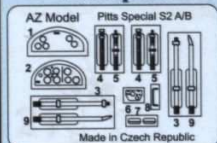

#### Fólie/ Foil



#### Resinové díly/ Resin parts



### Pro všechny verze, podle kamufláží For all versions, according to camouflage

#### Průhledné díly/ Clear parts



## Symbols/Symboly

Drill hole



Vyvrtat

Cyanoacrylate



Vteřinové lepidlo

Remove



Odstranit

Reduce



Zbrousit

Make new



Vyrobít

Option



Volba

Bend



Ohnout

Putty



Tmel

	Colour name	Humbrol		Colour name	Humbrol
A	Black	H33	E	Dark Brown	H186
B	White	H34	F	Dark Blue	H15
C	Light Grey	H64	G	Leather	H62
D	Silver	H11			



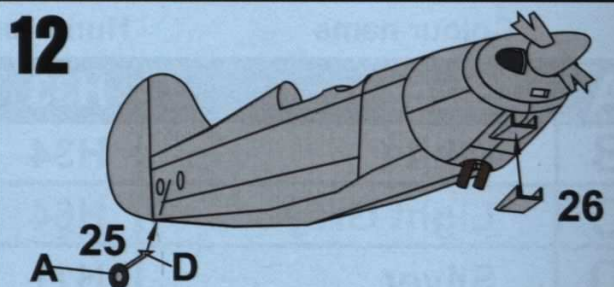
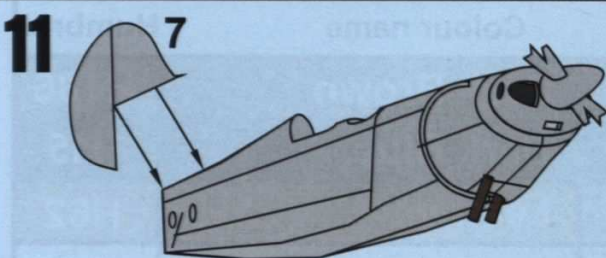
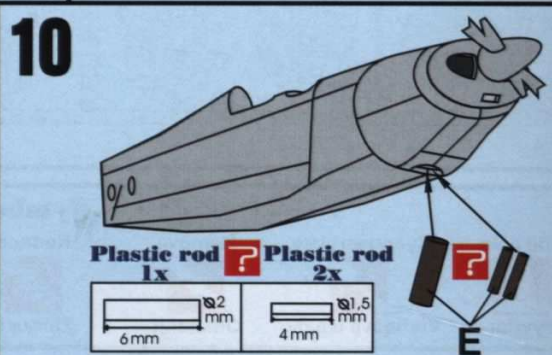
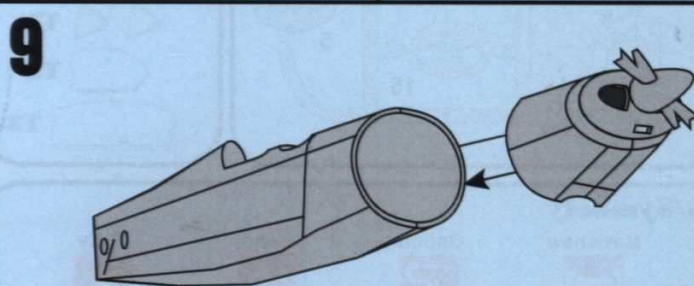
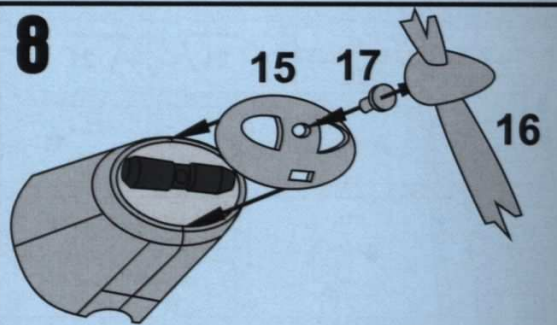
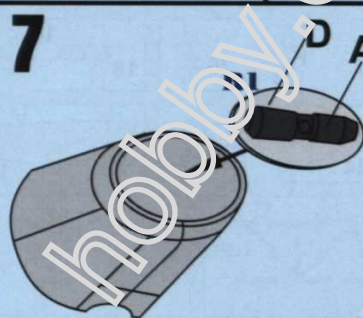
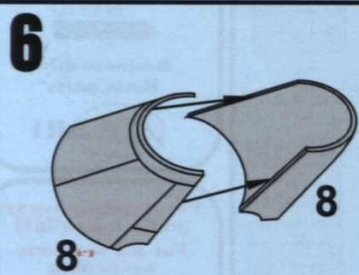
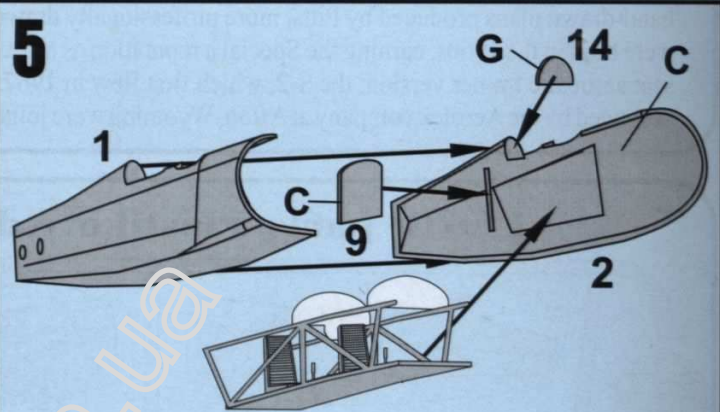
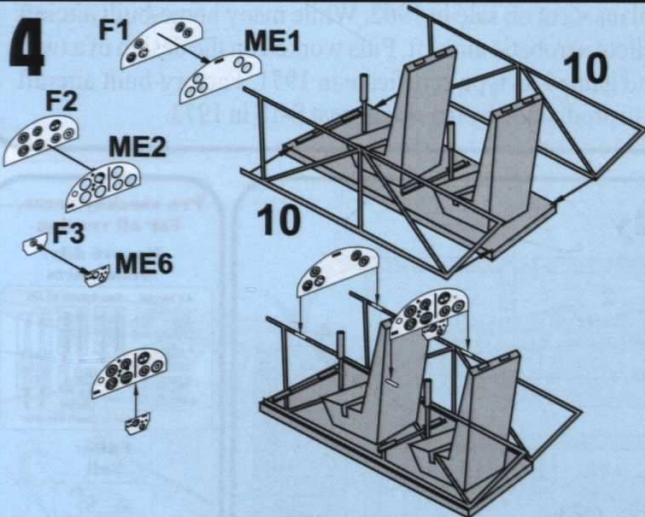
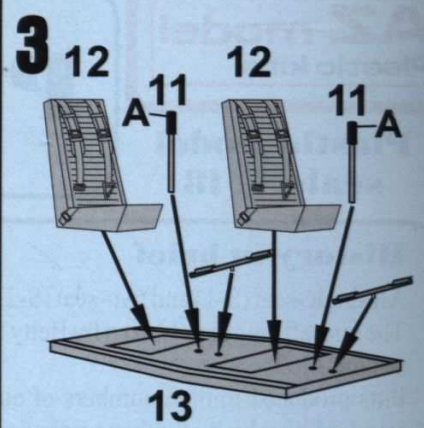
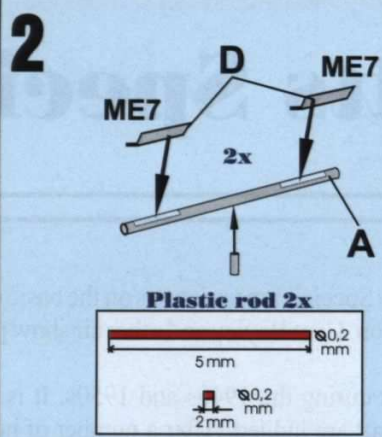
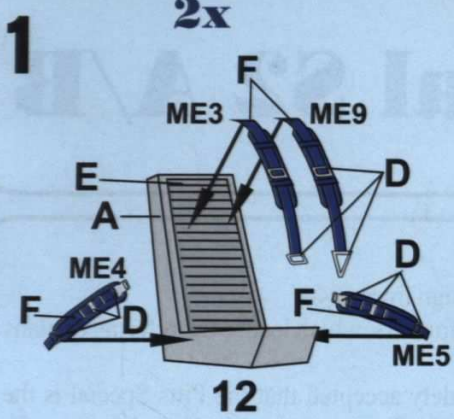



Stavební postup - Assembly instructions

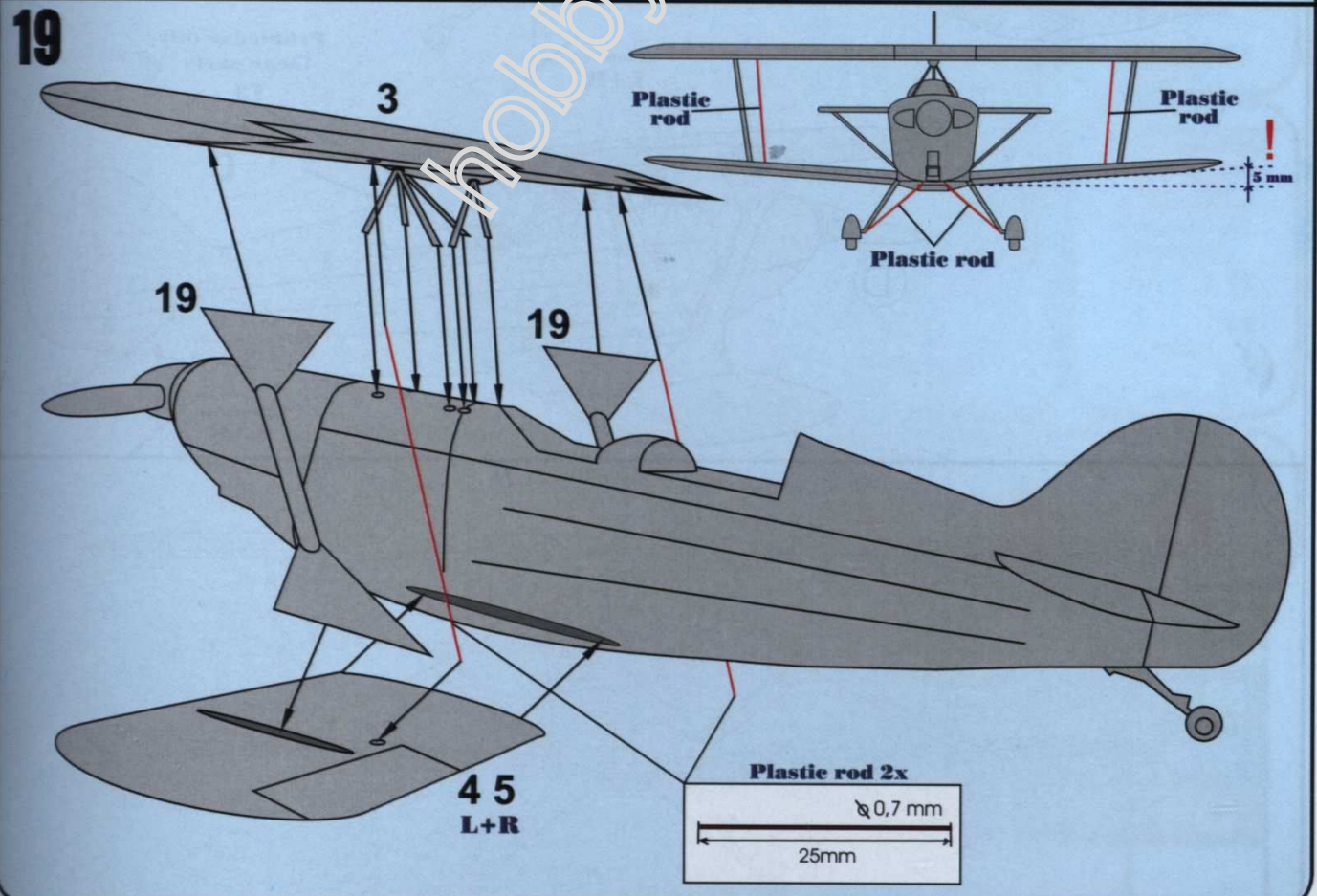
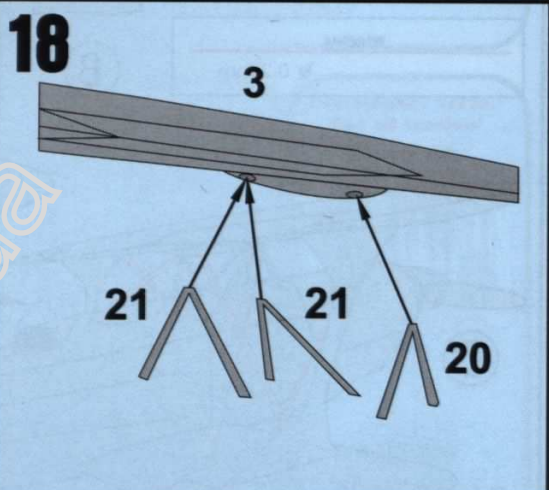
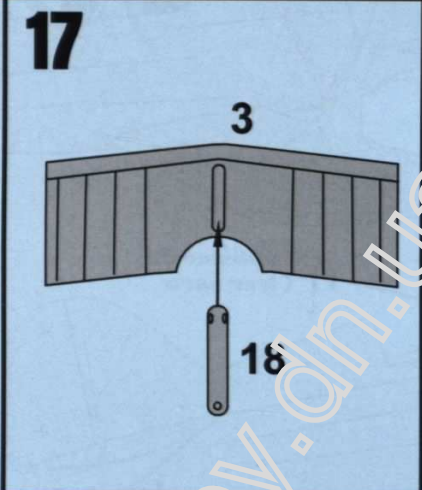
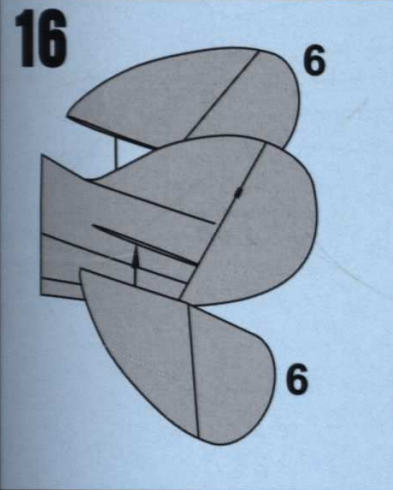
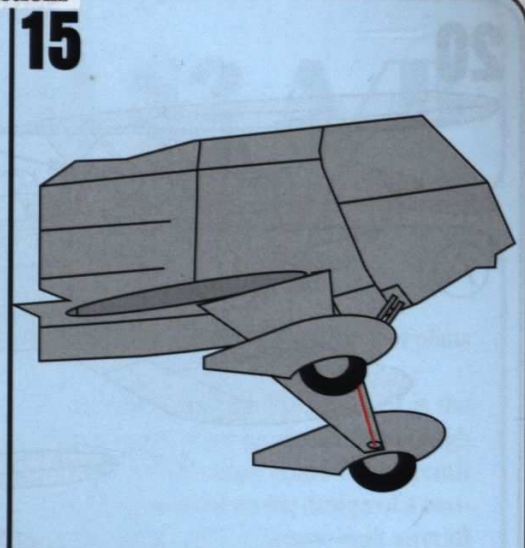
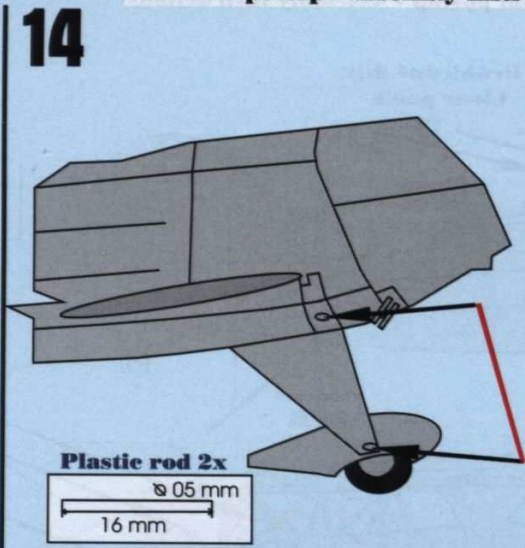
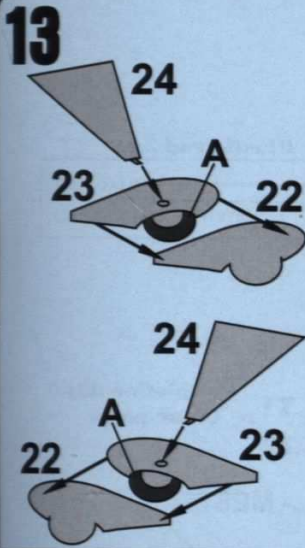



20

