



# Spitfire Mk.Vb/ trop interior S.A.

eduard

32 737

1/32 scale detail set for Hobby Boss kit • sada detailů pro model 1/32 Hobby Boss

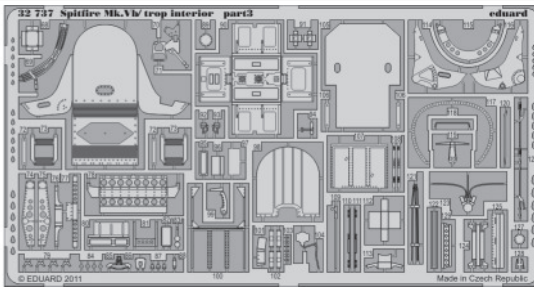

- APPLY EXPRESS MASK AND PAINT BEFORE GLUING  
POUŽIT EXPRESS MASK NABARVIT PŘED SLEPENÍM
- SYMMETRICAL ASSEMBLY  
SYMETRICKÁ MONTÁŽ
- REMOVE  
ODSTRANIT
- GRIND  
OBROUSIT
- DRILL HOLE  
VRTAT OTVOR
- BEND  
OHNOUT
- OPTION  
VOLBA
- REPLACE  
NAHRADIT



Film

ORIGINAL KIT PARTS  
PŮVODNÍ DÍLY STAVEBNICE

PHOTO-ETCHED PARTS  
LEPTANÉ DÍLY

PARTS TO BE REMOVED  
DÍLY K ODSTRANĚNÍ

FILL  
TMELIT

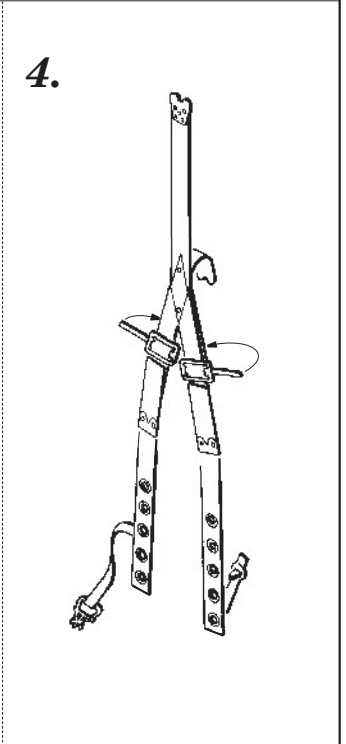
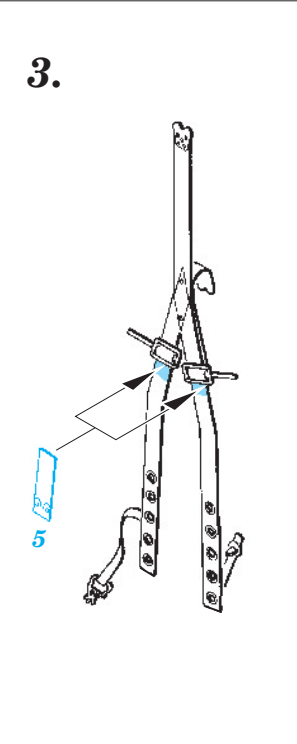
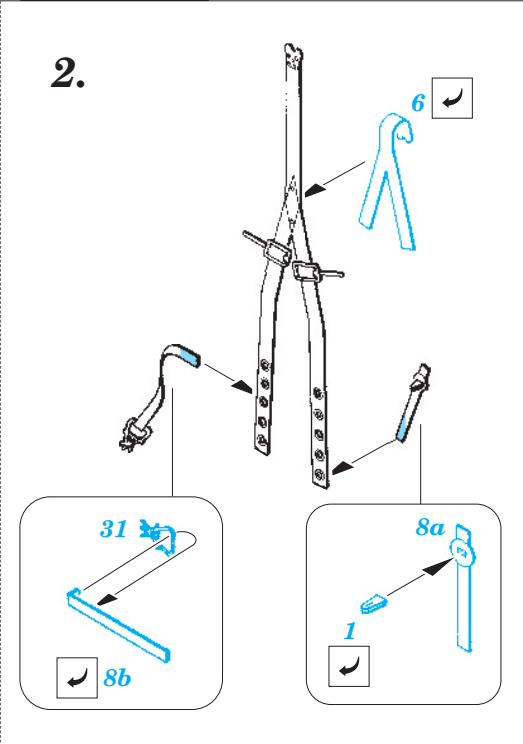
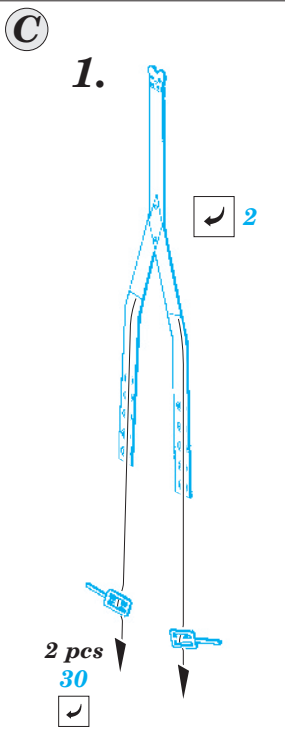
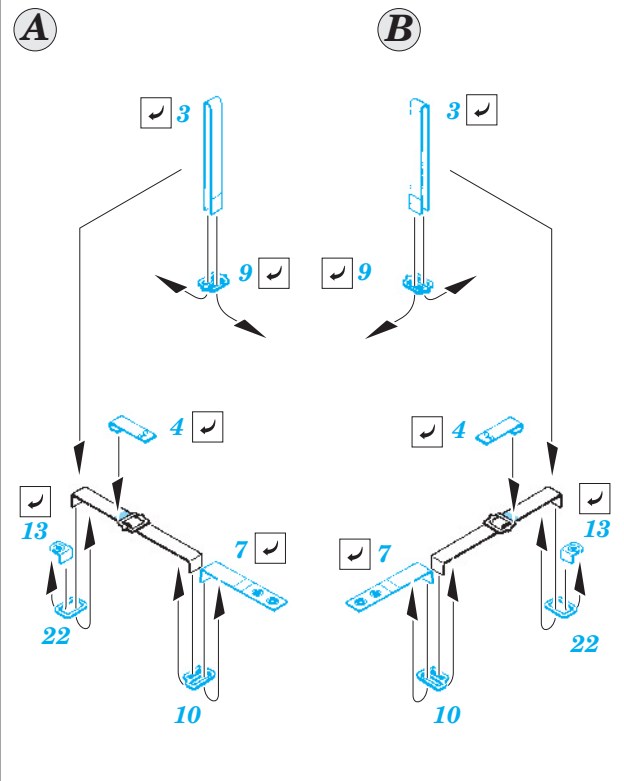
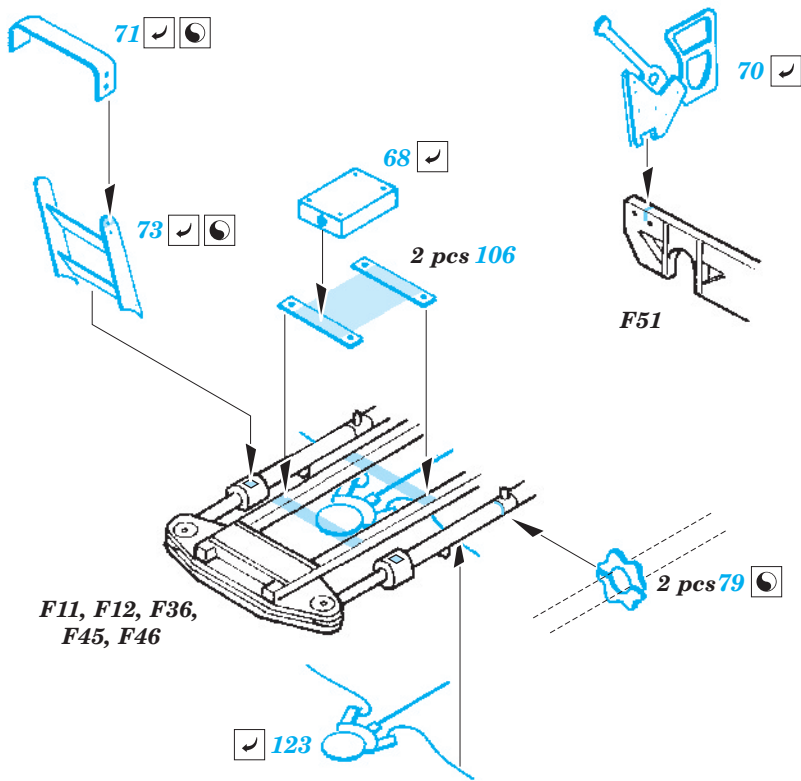

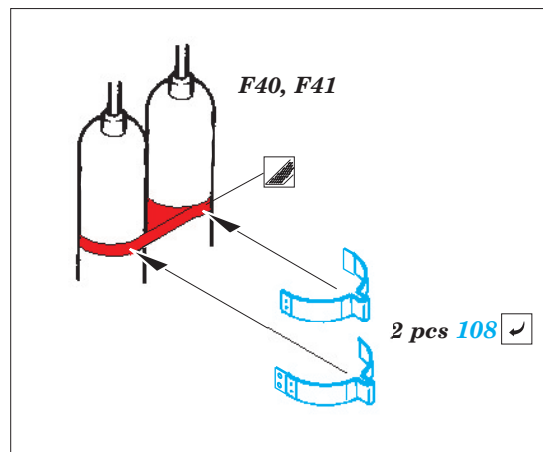
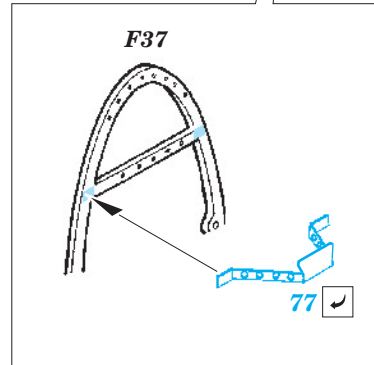
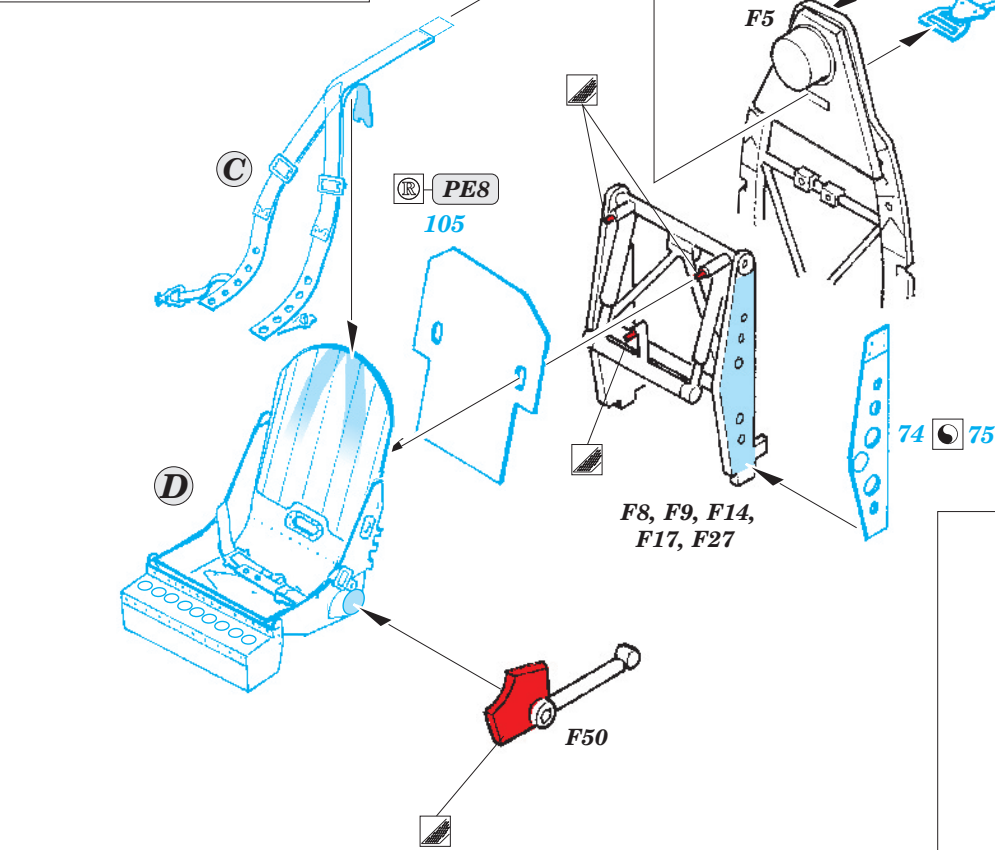
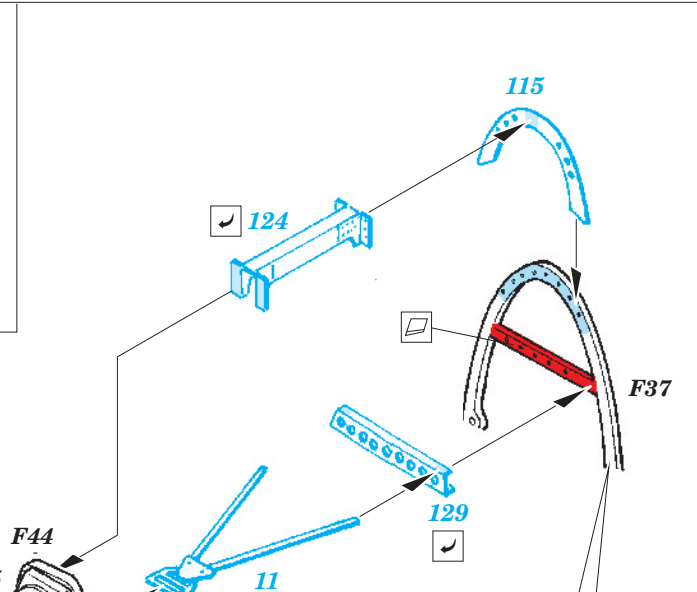
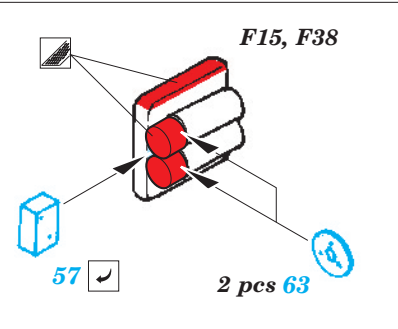
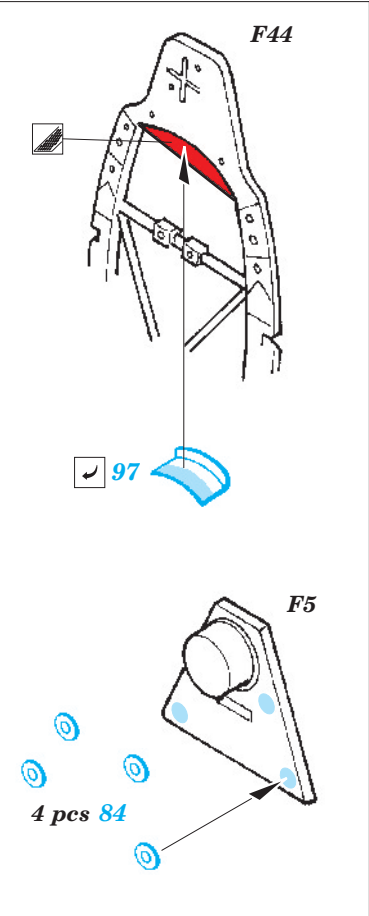
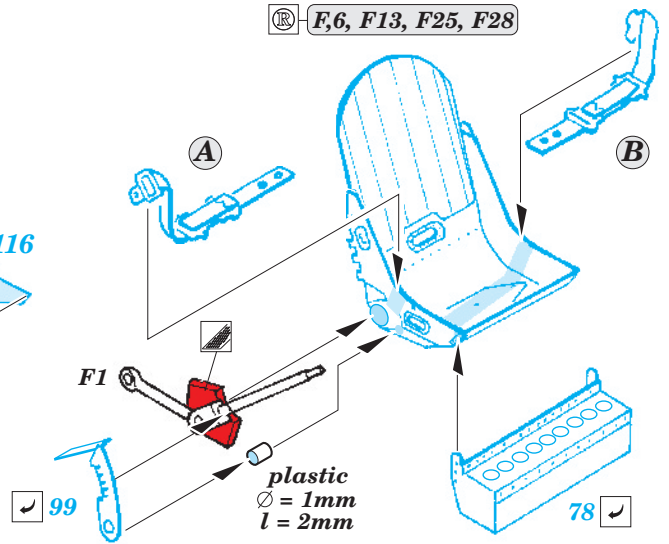
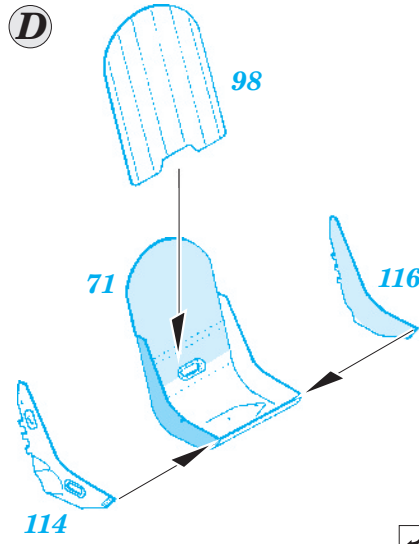
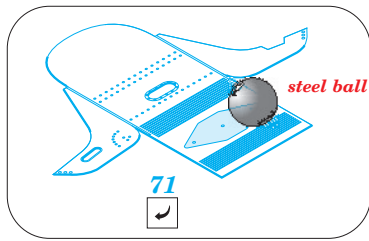

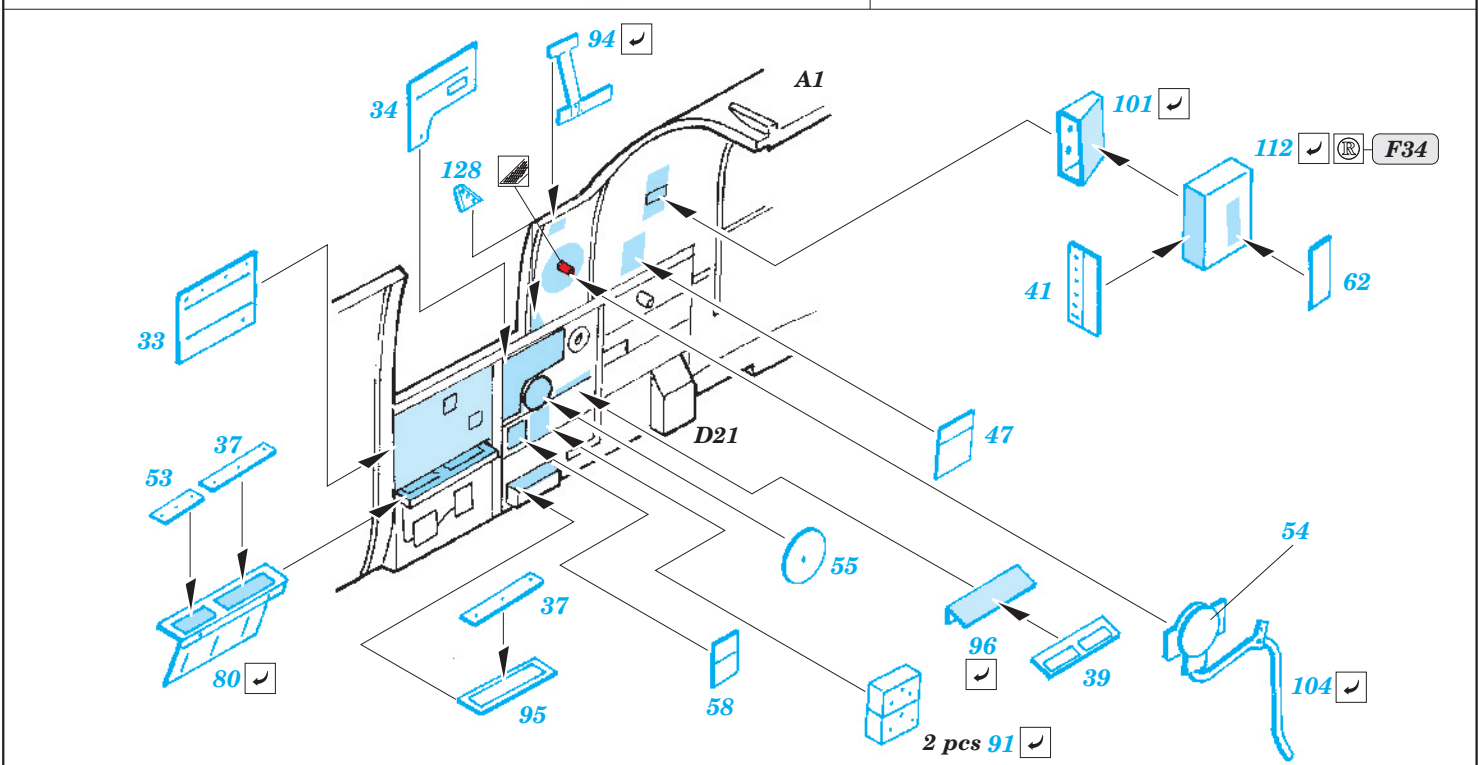
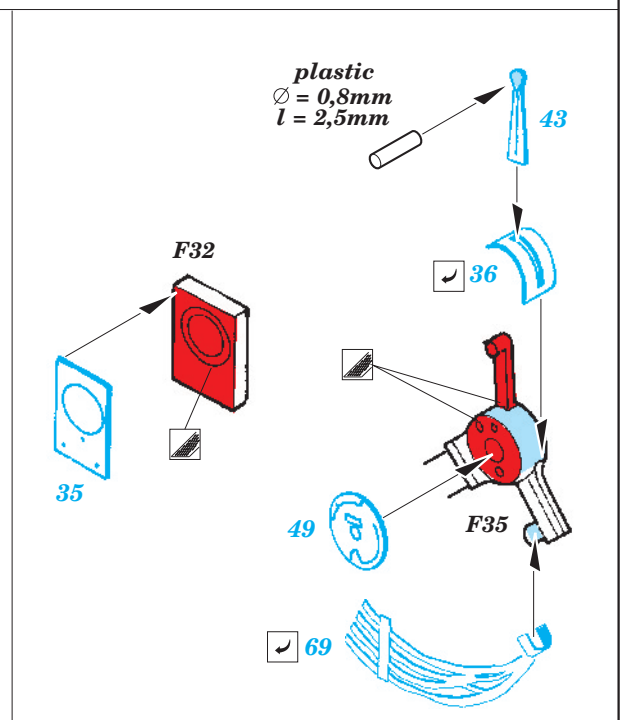
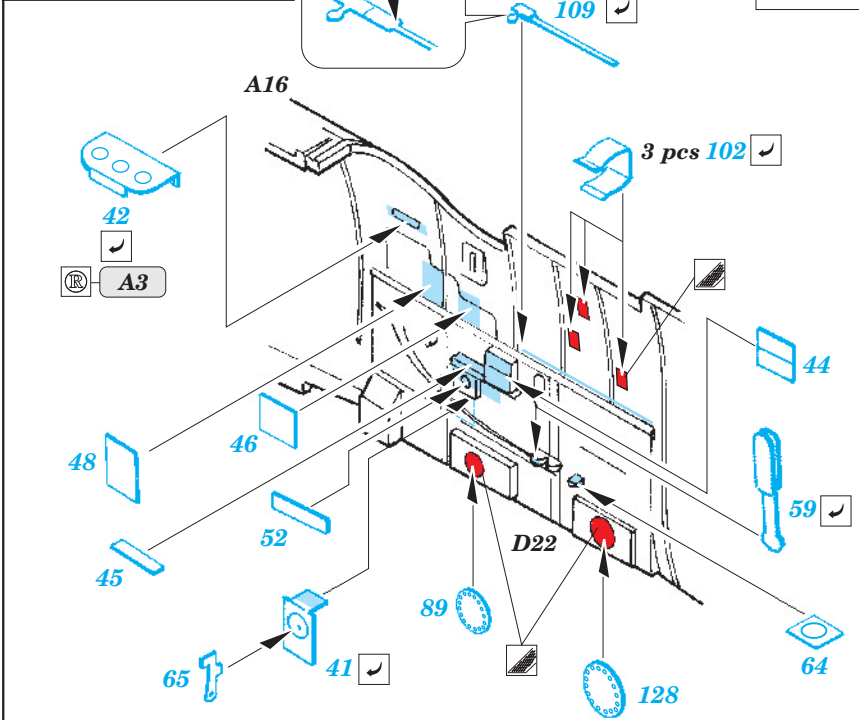
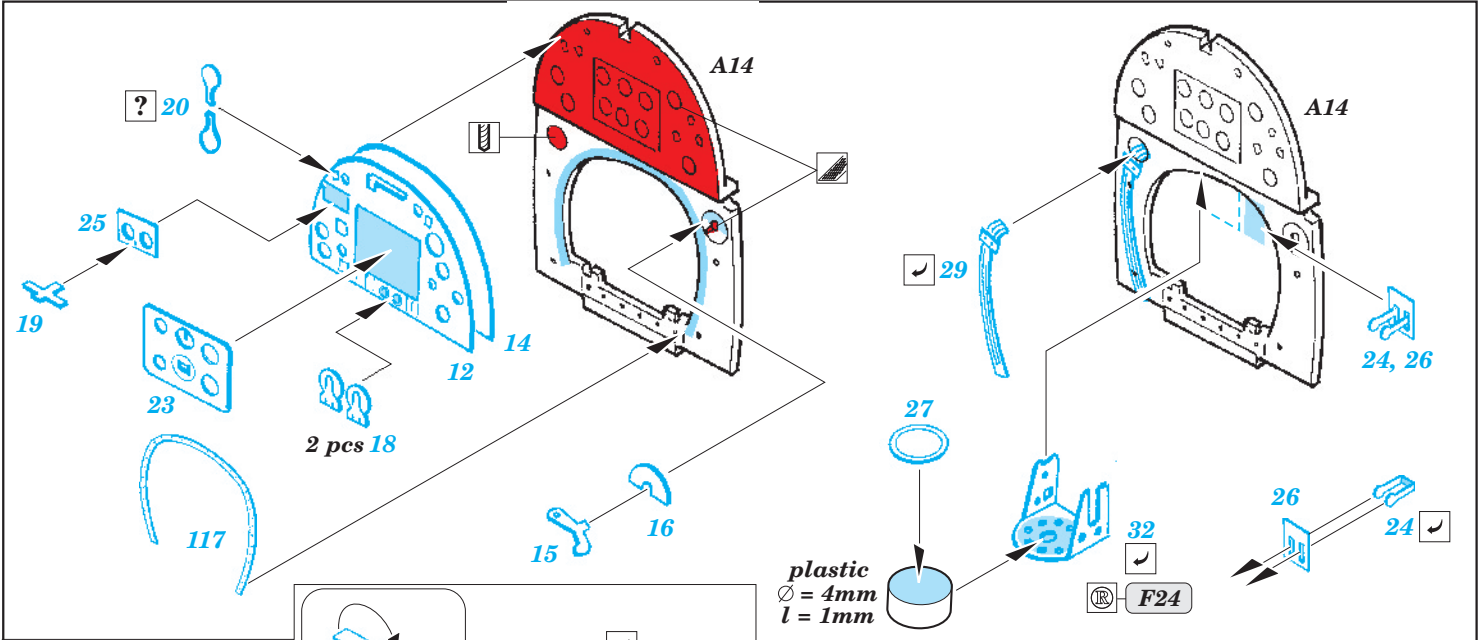

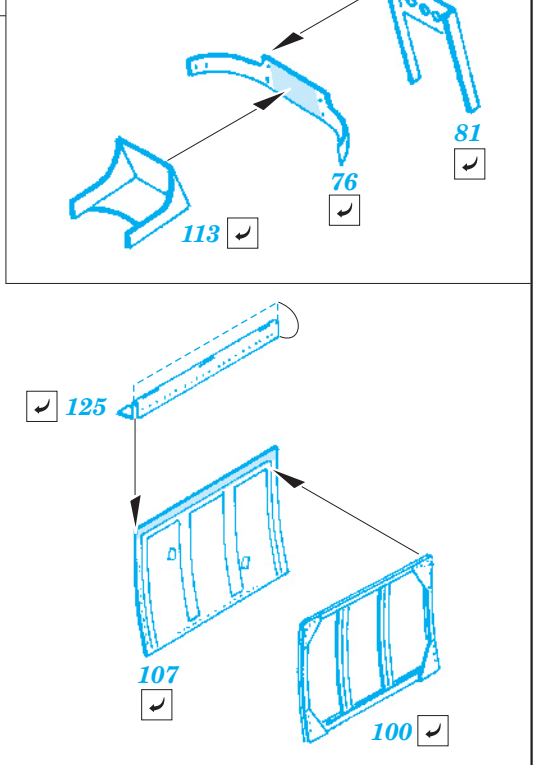
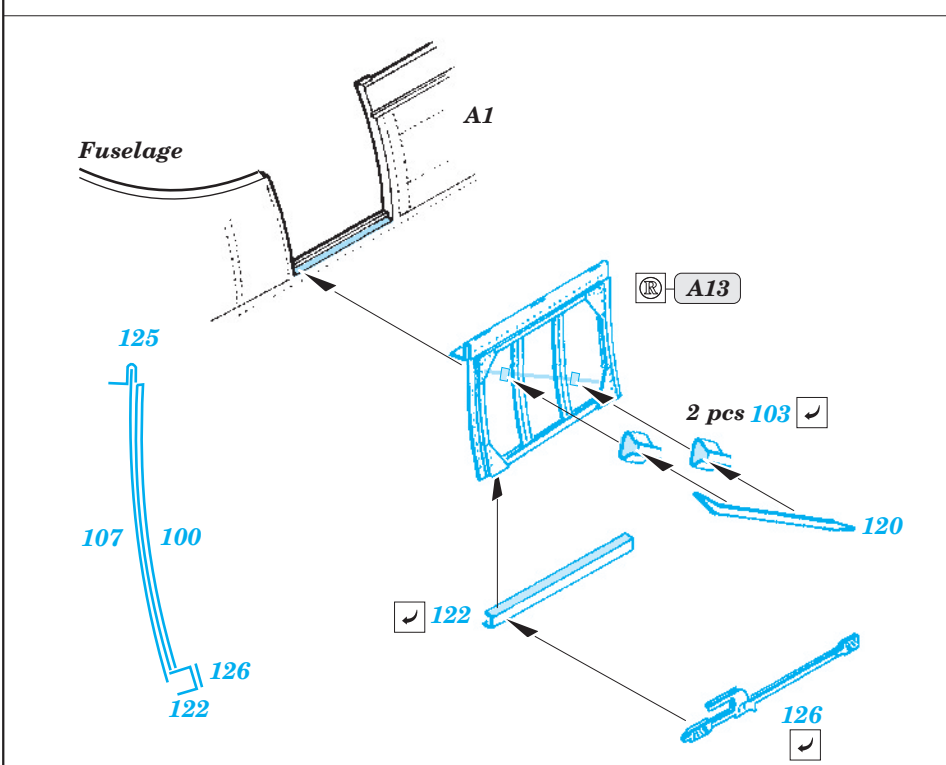
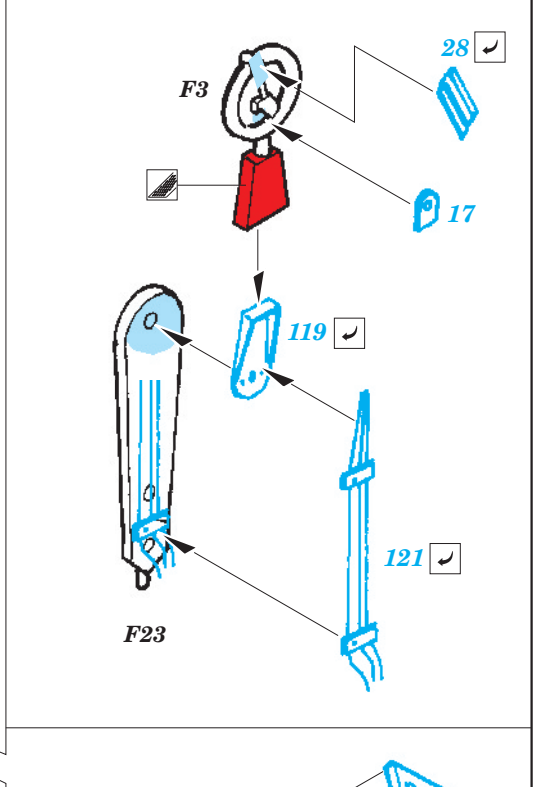
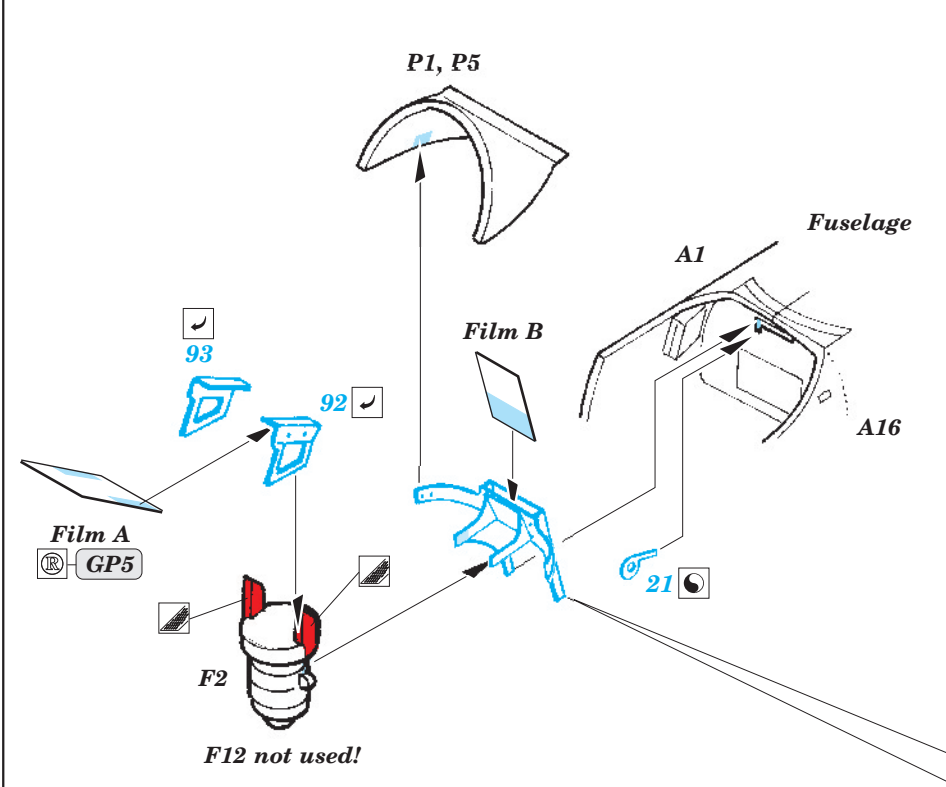
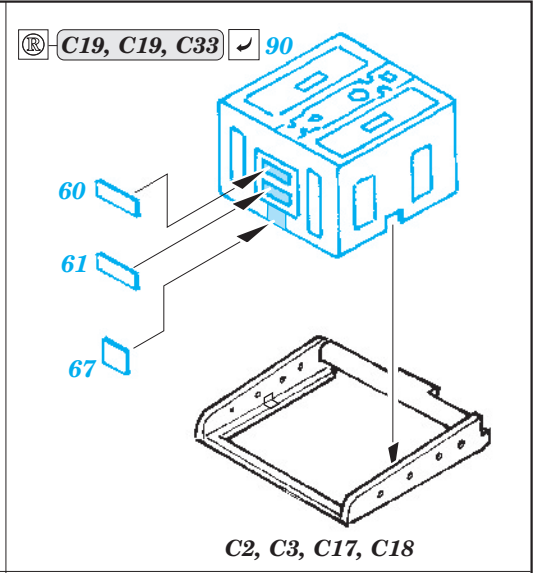
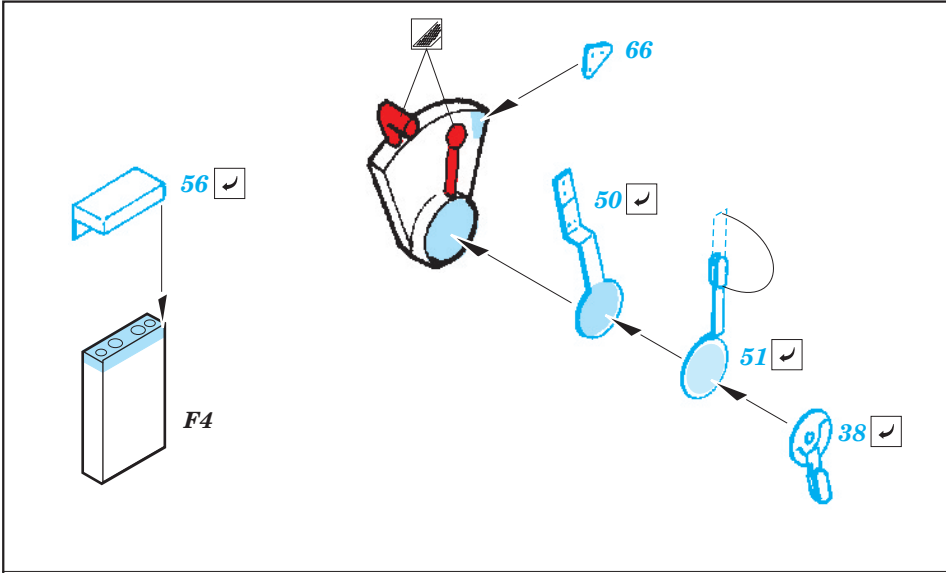

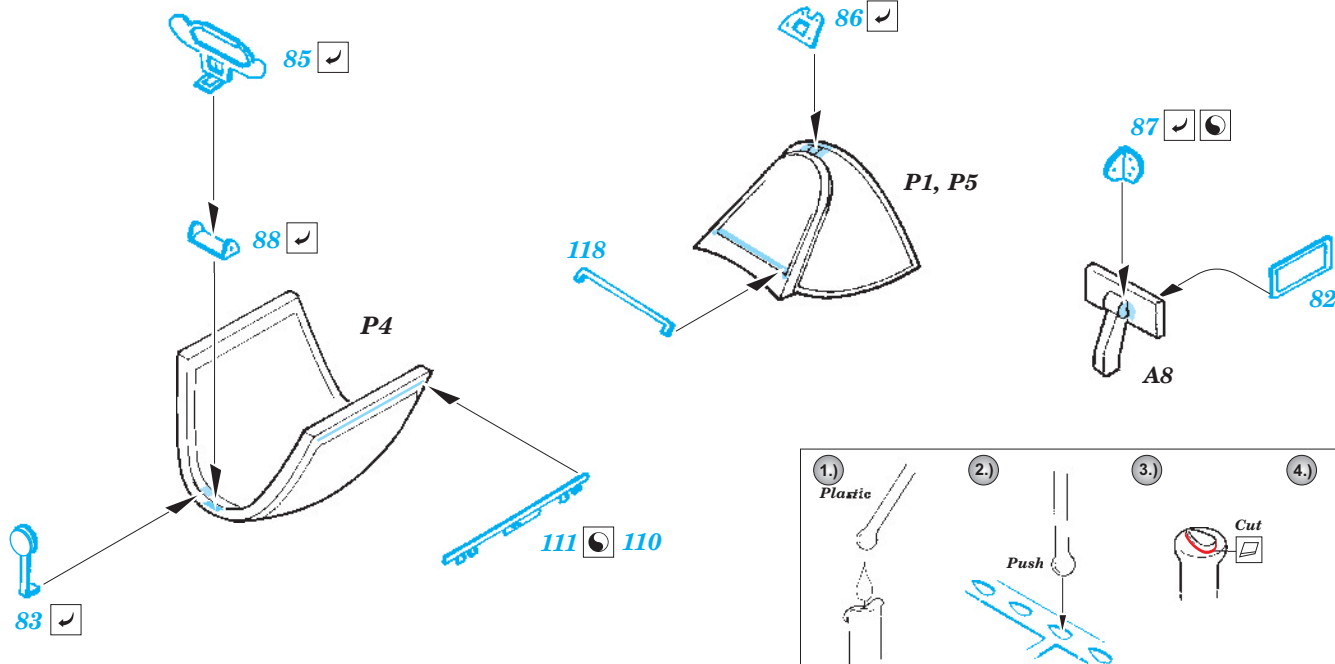

## PARTS WITH GLUE • DÍLY OPATŘENÉ LEPIDLEM

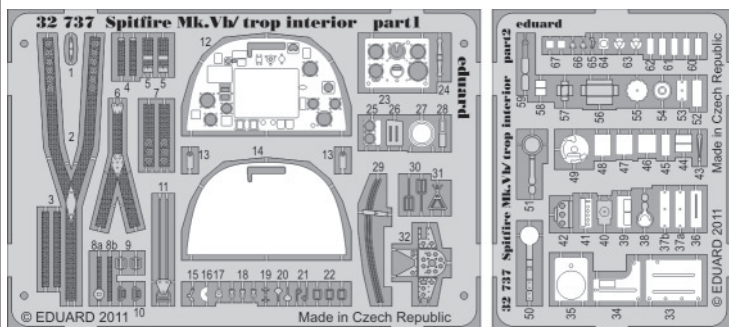

- Do not touch the adhesive areas of the etched components.
- Nesahejte na části dílů, na kterých je naneseno lepidlo.

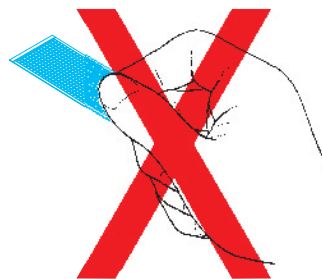

- Separate the etched components from their frames on the protective paper. Removal from the paper is done only after separation of the parts from the frames.

- Samolepící díly oddělujte od rámečku na podkladovém papíře. Po oddělení je sejměte z krycího papíru.

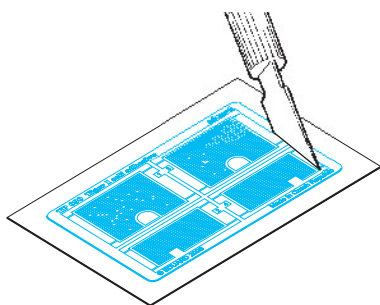

- Do not inadvertently place etched components on an unwanted surface. Attempts to remove will result in damage to your part.
- Nepokládejte samolepící díly na volné plochy. Pokud je omylem přilepíte, při pokusu o odlepení dojde k poškození dílu.

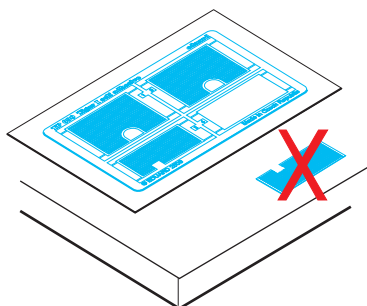

- Hold the parts by the edges, or at areas free of adhesive.
- Samolepící díly berte za hrany nebo za části, na kterých není nanesené lepidlo.

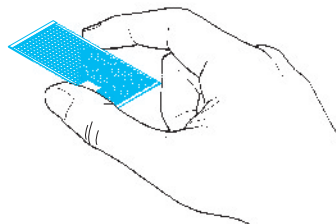

- Lightly place the component in the desired location and position. Adjust as required. The component will be permanently affixed when pressed onto its intended location, its location can be adjusted.
- Díl lehce položte do pozice, ve které má být nalepen. Upravte přesnou pozici a přimáčkněte. Díl dokonale přilne až po přimáčknutí, před přimáčknutím lze dílem opatrně manipulovat.

