

SSW D.III

eduard

GERMAN WWI FIGHTER

1/48 SCALE PLASTIC KIT

ProfiPACK
edition

#8256



INTRO

The Siemens-Schuckert Werke company began producing aircraft as early as 1907, but it wasn't until 1916 when the production capabilities rose to a higher standard.

In June 1916, Idflieg (air force inspection) issued a requirement for the development of an aircraft comparable to the Nieuport 11. One of the firms that decided to take part in this development was Siemens-Schuckert. It embarked on the road of copying the Nieuport 11, and called its aircraft SSW D.1. The aircraft went into production, but only 65 of an ordered 250 were completed by June 1917. The aircraft's performance fell short of that of its opponents, allied as well as German. One area in which the aircraft did excel, however, was in its rate of climb, which was achieved thanks to its nine cylinder rotary Siemens-Halske Sh.I engine. This engine rotated in the opposite direction of the propeller.

At that time, however, development was also underway of the Siemens-Halske Sh.III. The Idflieg was anticipating greater performance out of this unit. As soon as this engine became available, Idflieg ordered three SSW D.II prototypes. In one of them, D.IIb 3502/16, factory pilot Hans Müller reached 7,000m in 35 minutes and 30 seconds, which was a new world climb record. Thanks to this demonstration, another nine prototypes were ordered, two of which, D.7551/17 and D.7552/17, received the designation SSW D.III. The first flew for the first time on November 15, 1917, the other on December 20.

Six days after the first flight of the second D.III, SSW received an order for twenty pre-series D.IIIs. They were to be compared to other aircraft, and also be subjected to front line testing. Comparing to other types, however, such as the Fokker D.VII, were not very celebratory. It became evident, that the type required an experienced pilot. In the end, the type proved considerable faster than the Albatros D.V. and a little faster than the D.VII.

Nevertheless, the answer to the speed of the D.III became the SSW D.IV with a redesigned wing.

In the end, Idflieg ordered 30 series production D.IIIs on March 1, 1918. To this was added another order for fifty aircraft on March 23 and another fifty D.IVs on April 8.

Front line trials of 41 D.IIIs and one D.IV were undertaken between March 16 and May 18 with Jagdgeschwader II. Pilots praised the aircraft's climb rate, but still were demanding a higher speed. Engine troubles also appeared, but these were due to unsuitable oil.

In May, all aircraft were returned to the factory for major overhaul. These included a new shape of the rudder and elevators, a shorter wing span, a smaller spinner, a redesigned cowl, and so on. A 40 hour run test of the engine was also required. After the changes and engine test, the aircraft were returned to the front on July 22.

There was a second round of tests which resulted in three orders for the SSW D.IV totaling 250 aircraft.

The SSW D.IIIs were assigned to air defense units, and the faster, although slower climbing D.IVs, were delivered to units on the Western Front. The first kill was attained by Theo Osterkamp, an ace with an eventual total of 38 kills gained over both world wars, when, on August 21, 1918, he shot down a DH.9 bomber.

Documentation suggests a total of 136 SSW D.IIIs and D.IVs being issued to combat units.

E SSW D.III 3025/18, Trier, December 1918 to January 1919

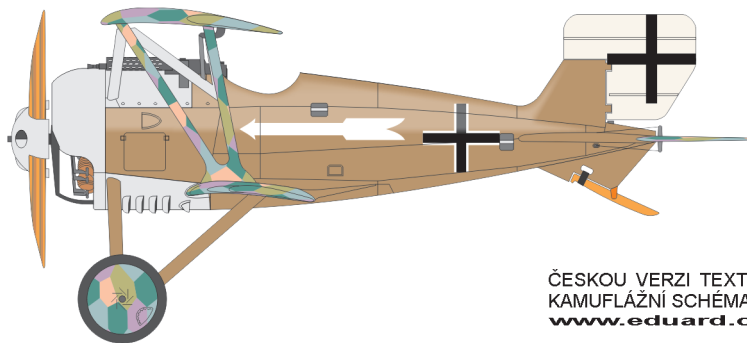

ČESKOU VERZI TEXTU A KOMPLETNÍ
KAMUFLÁŽNÍ SCHÉMA NALEZNETE NA
www.eduard.com/s/8256

8256 - NAV2

ATTENTION



UPOZORNĚNÍ



ACHTUNG



ATTENTION



注意



Carefully read instruction sheet before assembling. When you use glue or paint, do not use near open flame and use in well ventilated room. Keep out of reach of small children. Children must not be allowed to suck any part, or pull vinyl bag over the head.



Před započatím stavby si pečlivě prostudujte stavební návod. Při používání barev a lepidel pracujte v dobře větrané místnosti. Lepidla ani barvy nepoužívejte v blízkosti otevřeného ohně. Model není určen malým dětem, mohlo by dojít k požití drobných dílů.

INSTRUCTION SIGNS * INSTR. SYMBOLS * INSTRUKTION SINNBILDEN * SYMBOLES * 記号の説明

OPTIONAL
VOLBABEND
OHNOUTOPEN HOLE
VYVRTAT OTVORSYMMETRICAL ASSEMBLY
SYMETRICKÁ MONTÁŽNOTCH
ZÁREZREMOVE
ODRÍZNOUTAPPLY EDUARD MASK
AND PAINT
POUŽÍ EDUARD'S MASK
NABARVIT

PARTS



DÍLY



TEILE



PIĚCES



部品

PLASTIC PARTS

A>

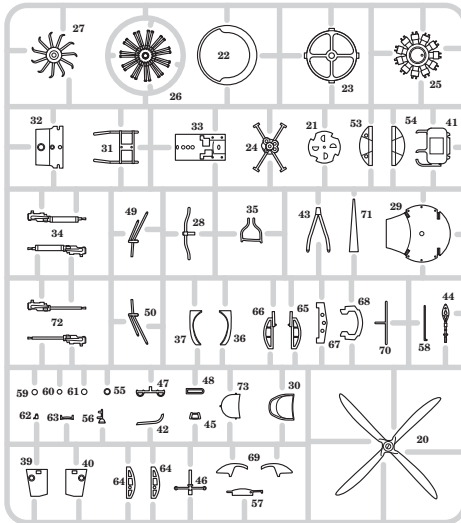

B>

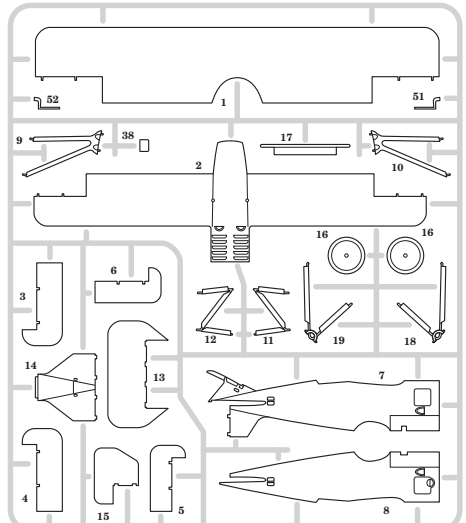

PE - PHOTO ETCHED DETAIL PARTS

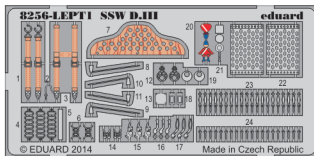
eduard
MASK

FILM



-Parts not for use. -Teile werden nicht verwendet. -Pièces à ne pas utiliser. -Tyto díly nepoužívejte při stavbě. - 使用しない部品

COLOURS



BARVY



FARBEN



PEINTURE



色

GSI Creos (GUNZE)		
AQUEOUS	Mr.COLOR	
[H-2]	C2	BLACK
[H-11]	C62	FLAT WHITE
[H-12]	C33	FLAT BLACK
[H-13]		FLAT RED
[H-25]	C34	SKY BLUE
[H-37]	C43	WOOD BROWN

AQUEOUS	Mr.COLOR	
[H-47]	C41	RED BROWN
[H-53]	C13	NEUTRAL GRAY
Mr.METAL COLOR		
[MC211]		CHROME SILVER
[MC214]		DARK IRON
[MC218]		ALUMINIUM
[MC219]		BRASS

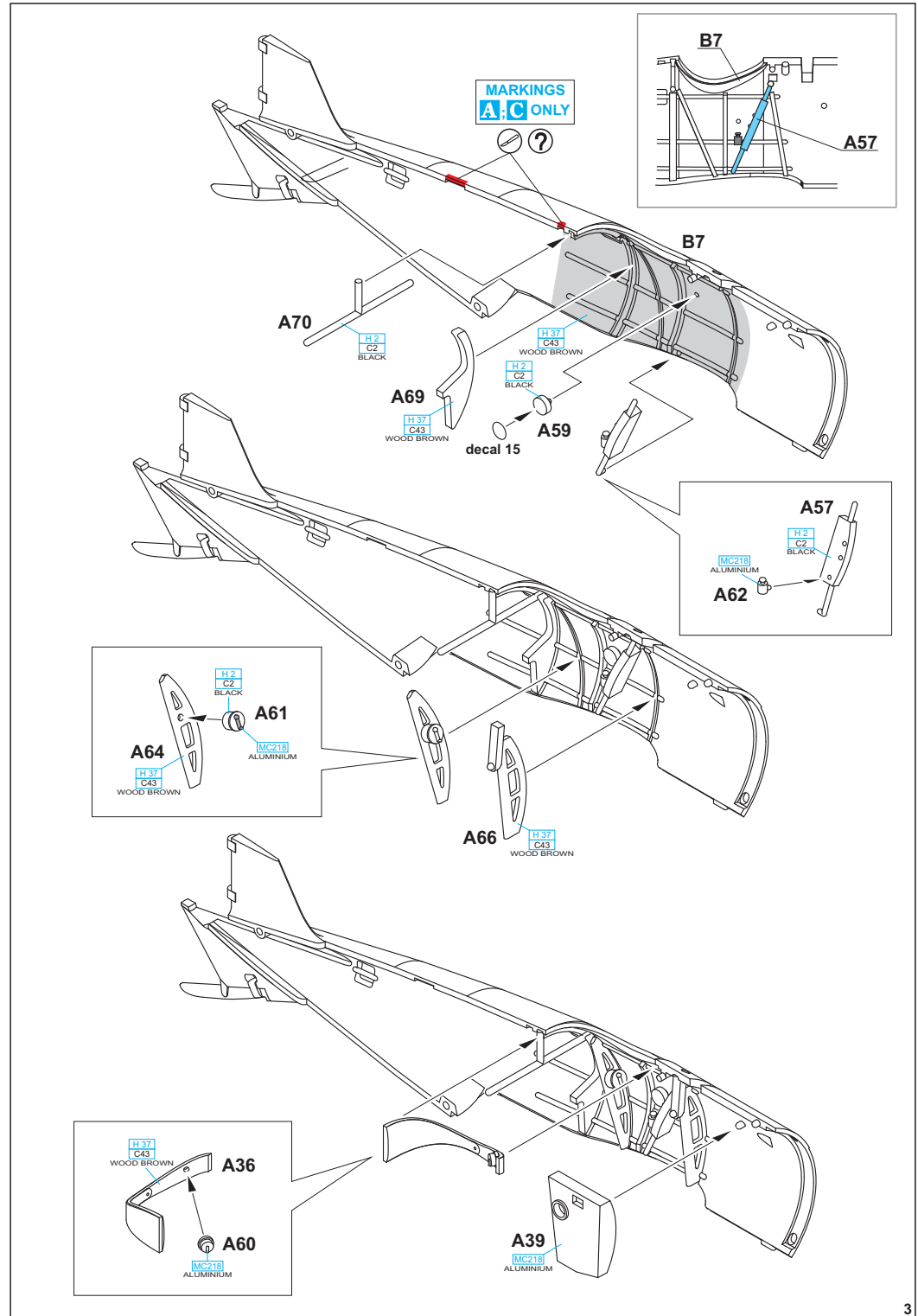

MARKINGS
A, C ONLY

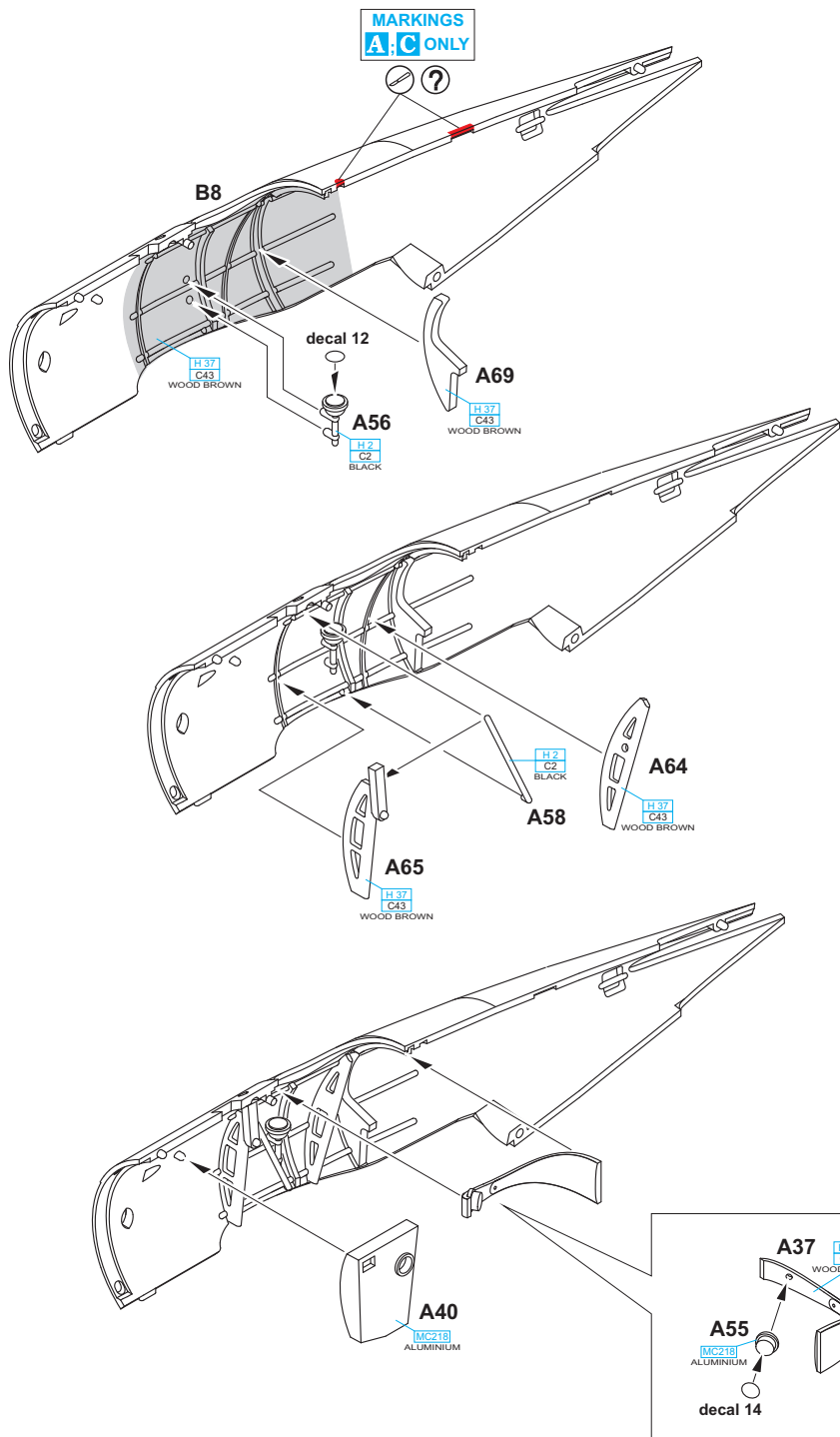

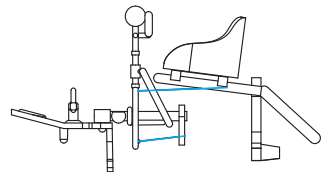
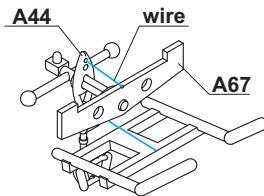
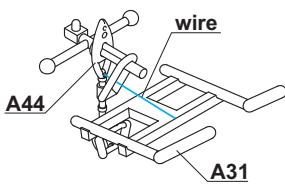
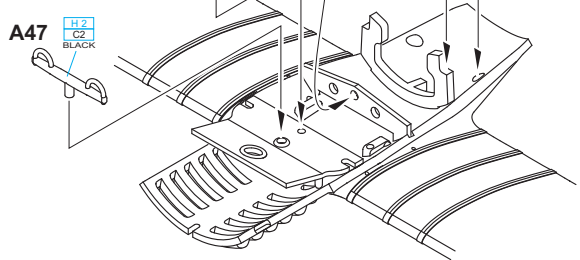
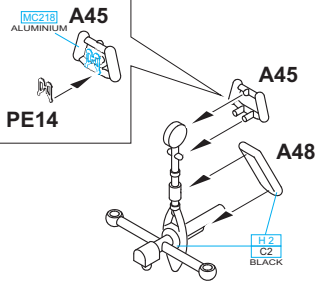
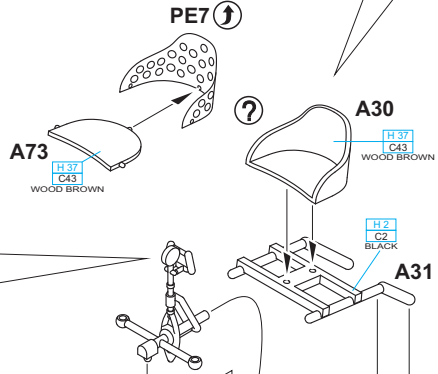
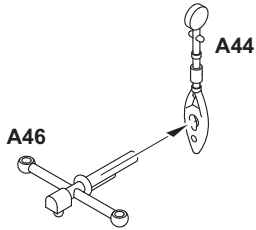
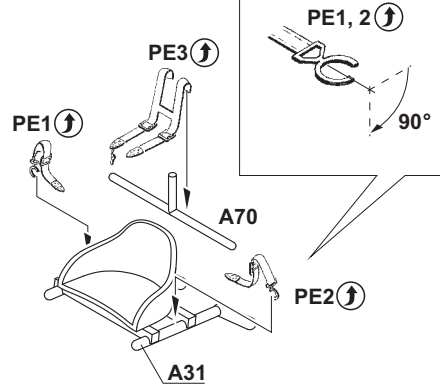
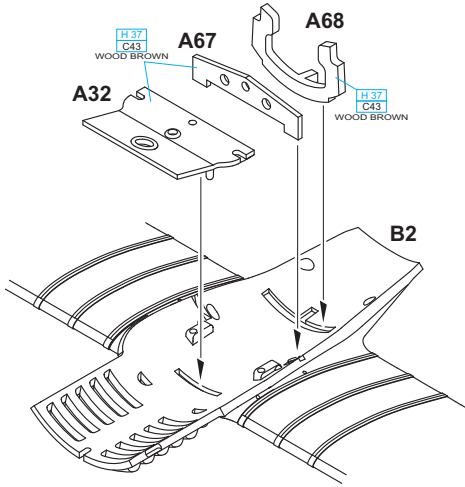

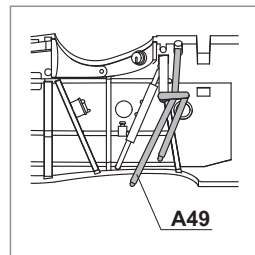
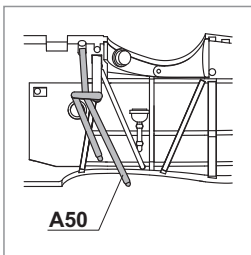
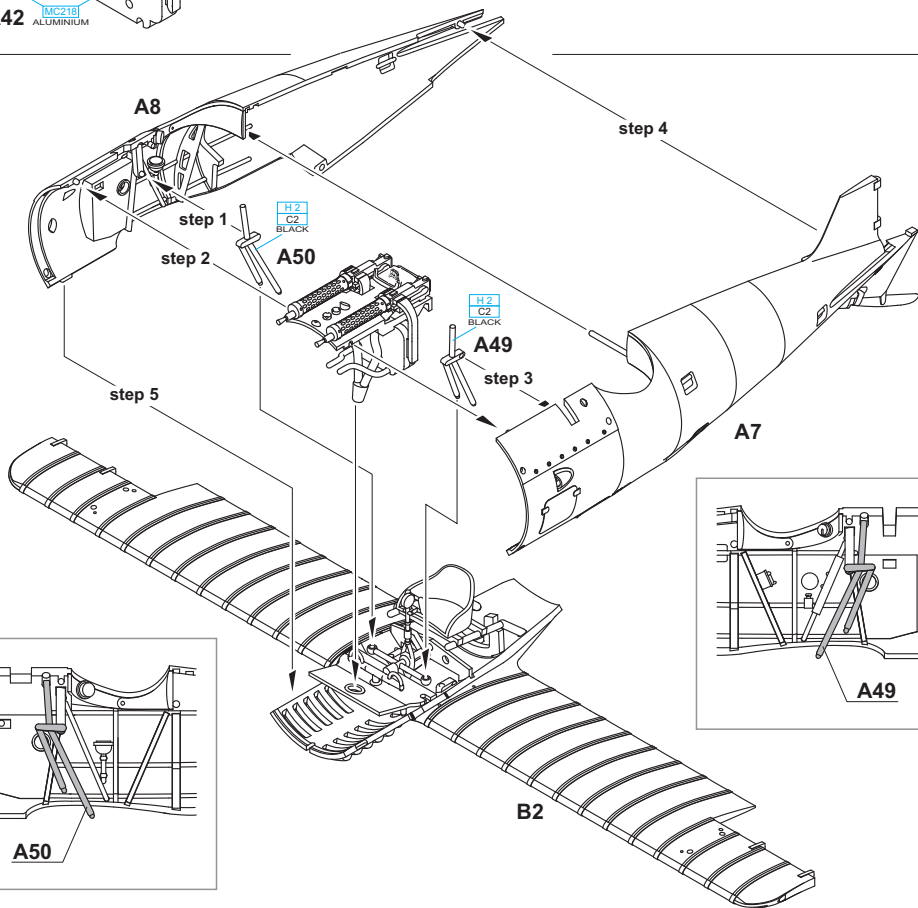
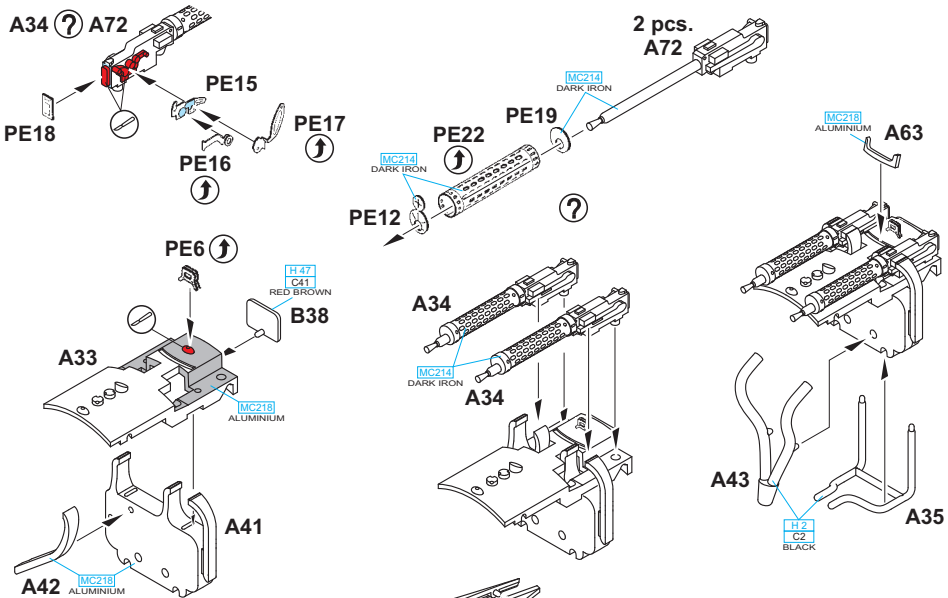

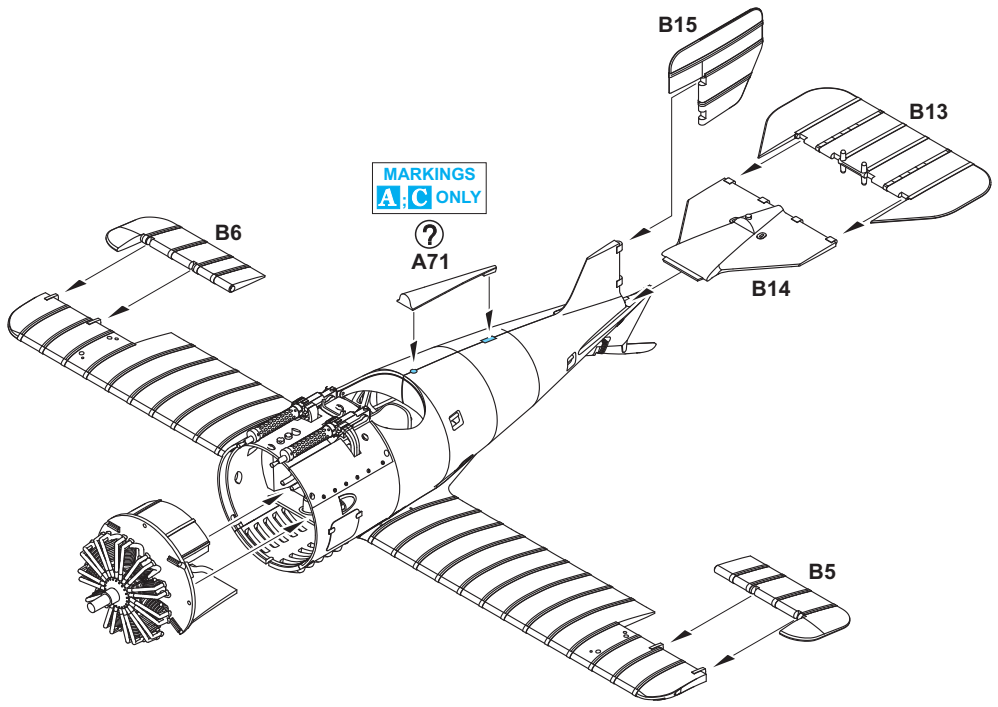
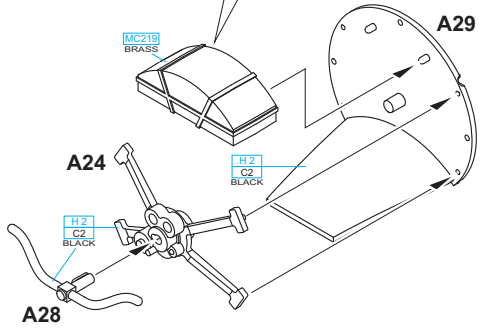
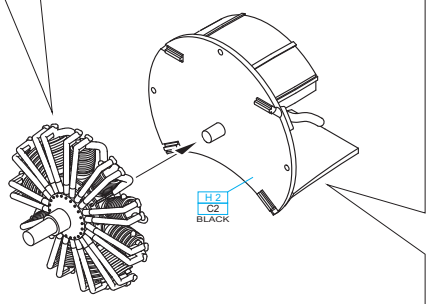
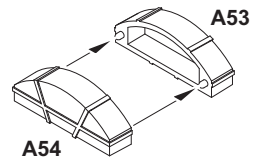
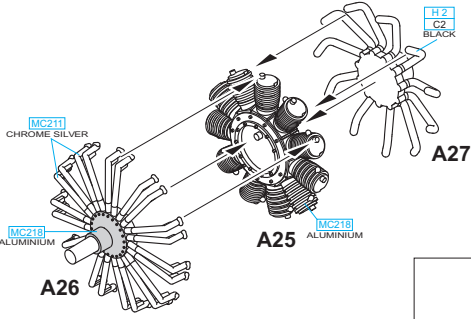

A

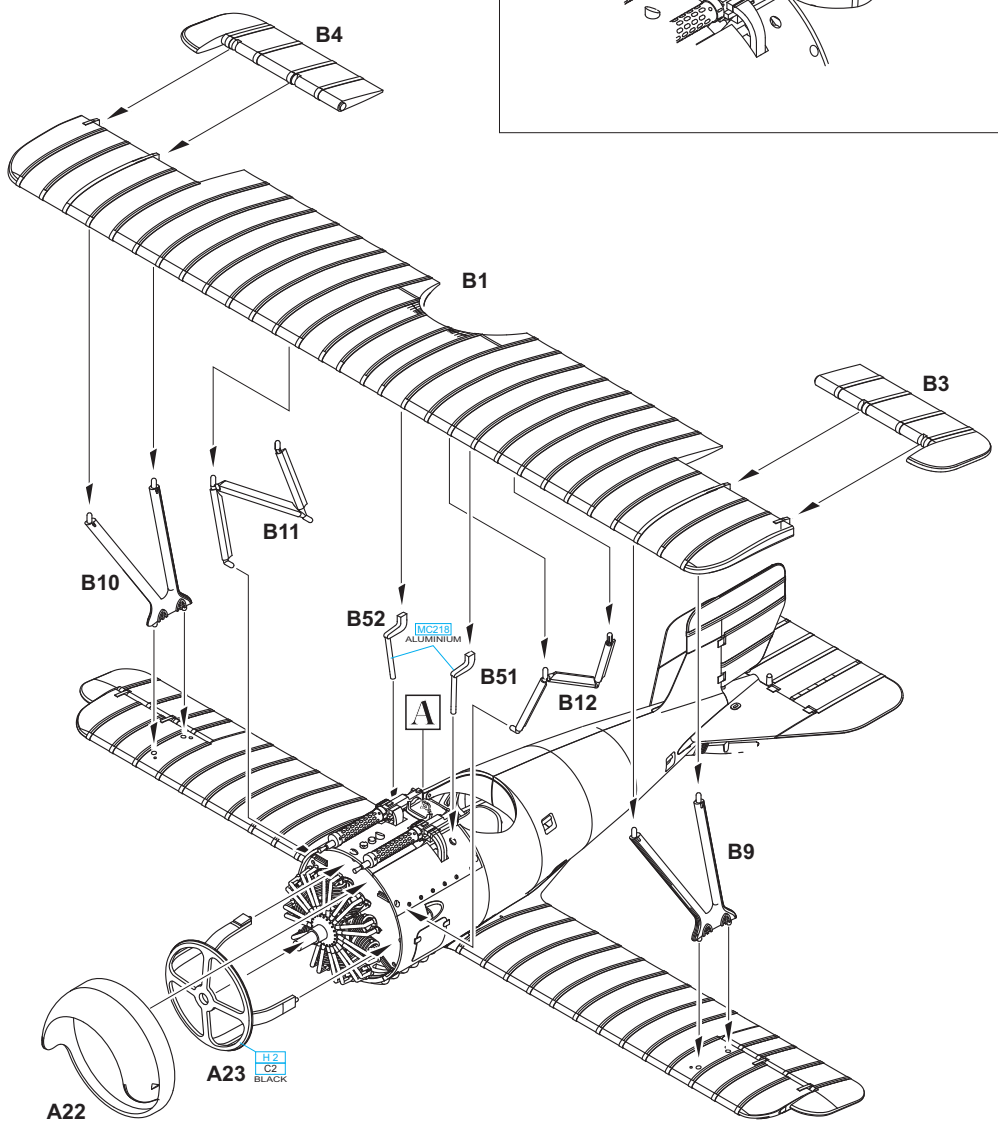
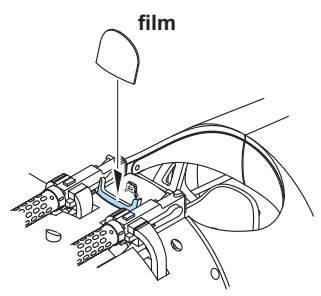

8256

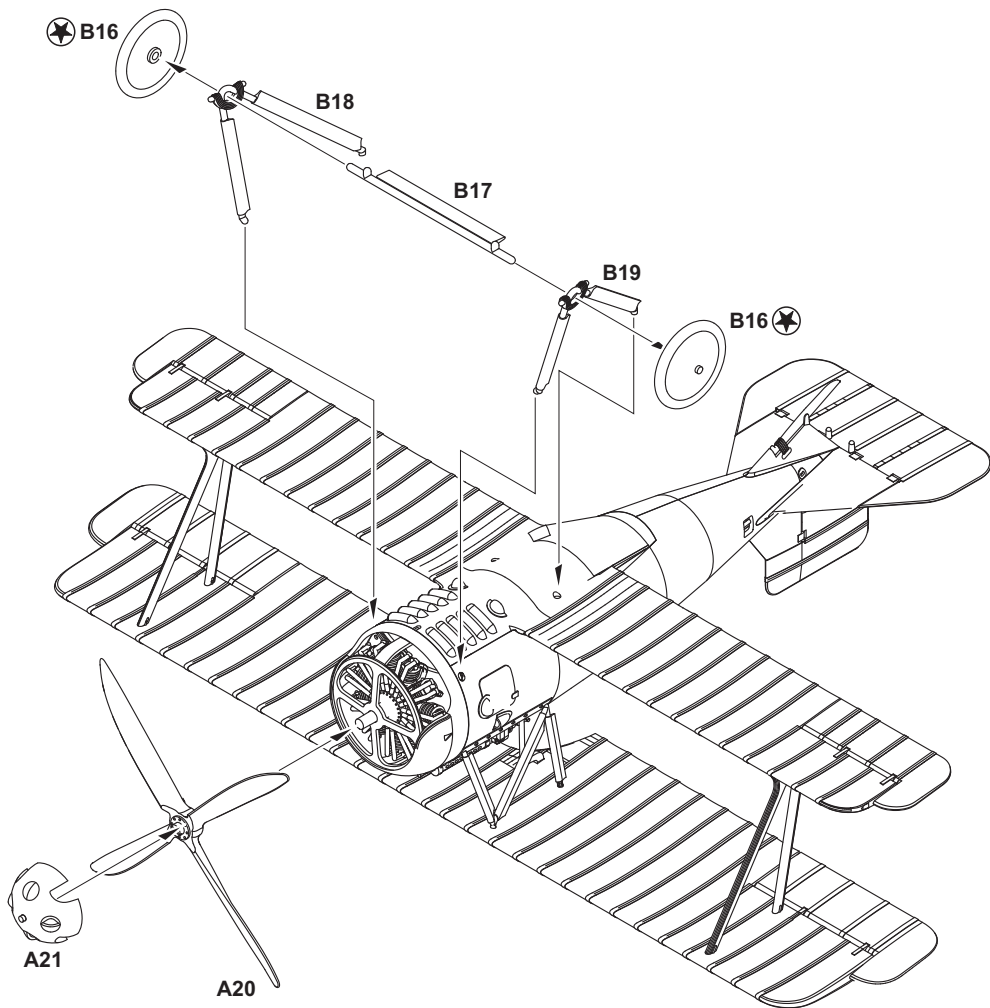
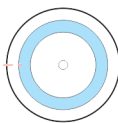
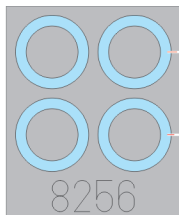

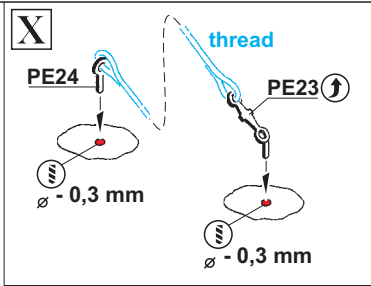

PE10 ↻ PE11
MC212
 DARK IRON

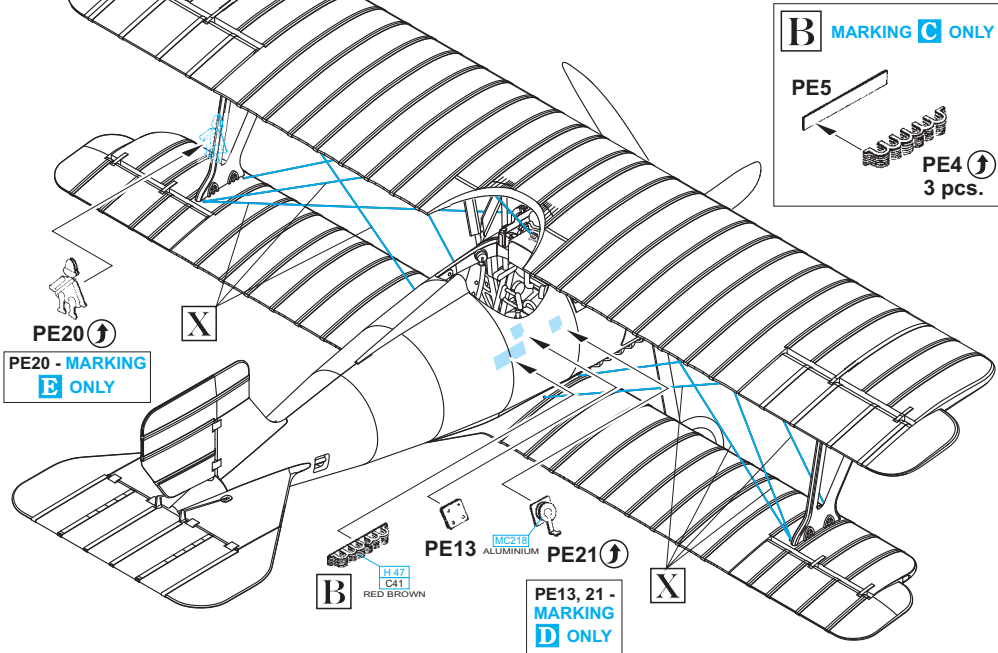
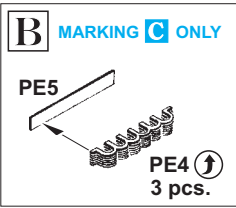
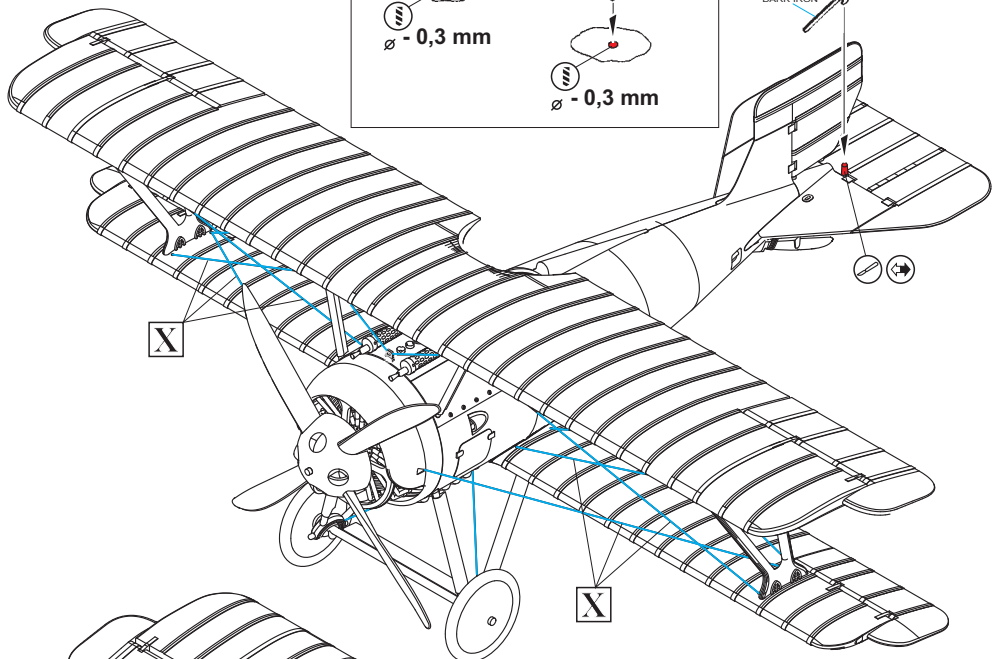

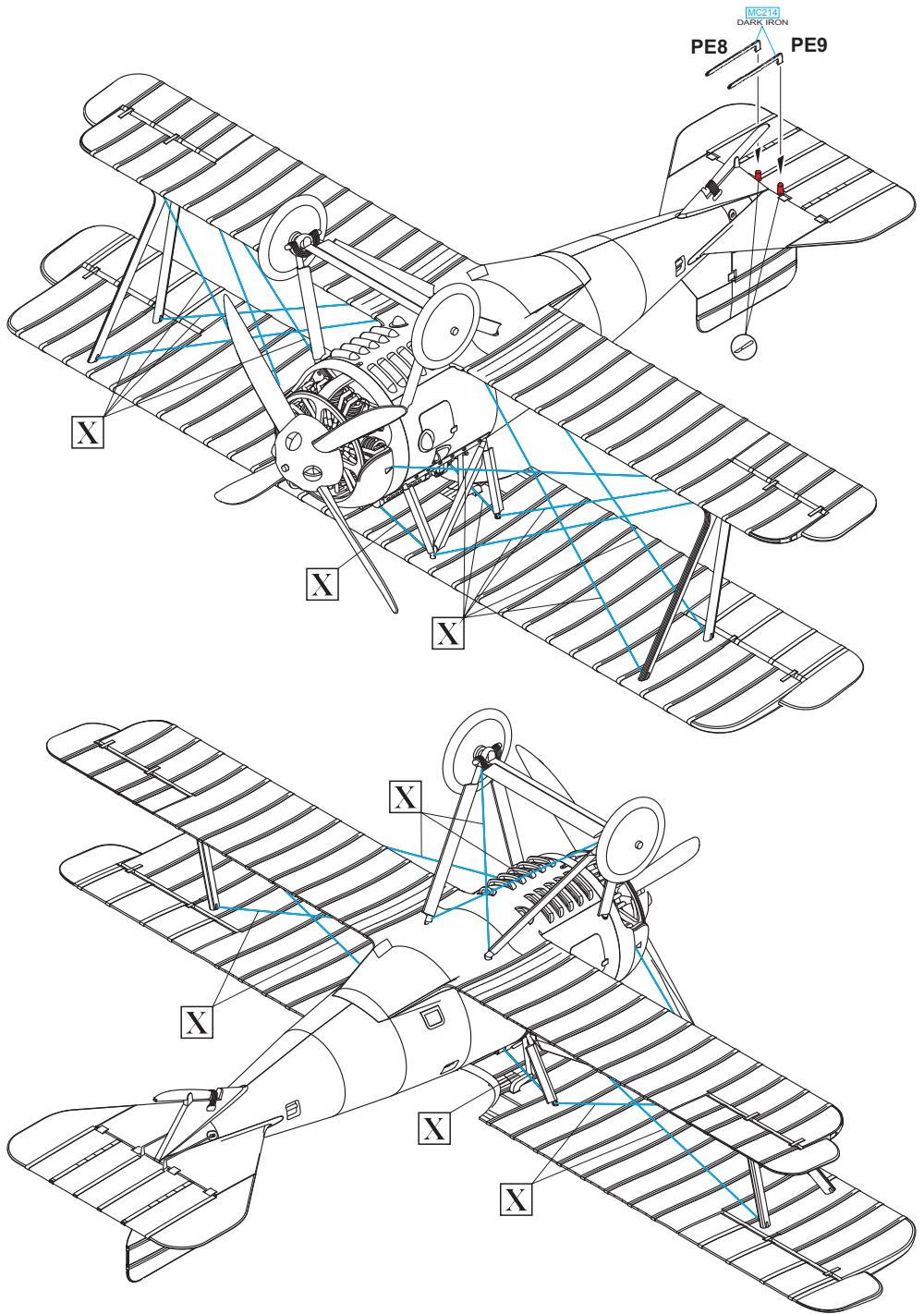

A SSW D.III, Jasta 4, Lt. Ernst Udet, Metz, October 3, 1918

Ernst Udet was photographed in the cockpit of this aircraft on October 3, 1918. He was a holder of the Pour-le-Merite and Knight's Cross, and was a 62 kill ace. But the Staffelführer of Jasta 4 never flew this aircraft in combat, and it is unlikely that he ever flew it at all. On September 26, seven DH.9s of No.99 Squadron IAF attacked the train station at Metz, and these were bounced by German aircraft on their return flight. Five of the bombers were downed over enemy territory, and two crash landed with dead gunners. Two of these kills were credited to Udet. He was wounded by a round to the thigh, and flew no more combat missions. The inscription LO! On the fuselage also appeared on other of Udet's aircraft. It was a familiar reference to his lady friend Eleonor Zink. The extent of the red paint on the aircraft is not entirely clear from available photographs.

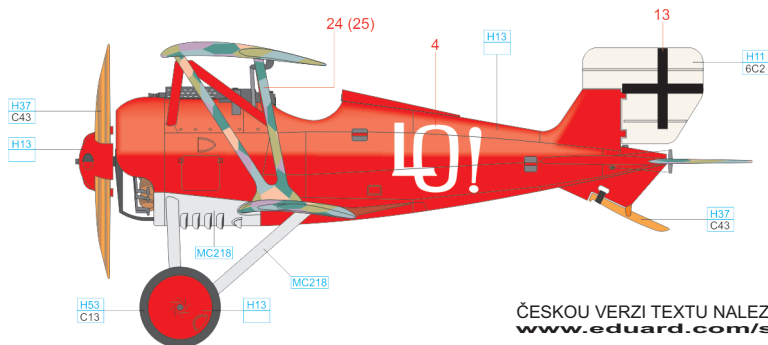

ČESKOU VERZI TEXTU NALEZNETE NA
www.eduard.com/s/8256

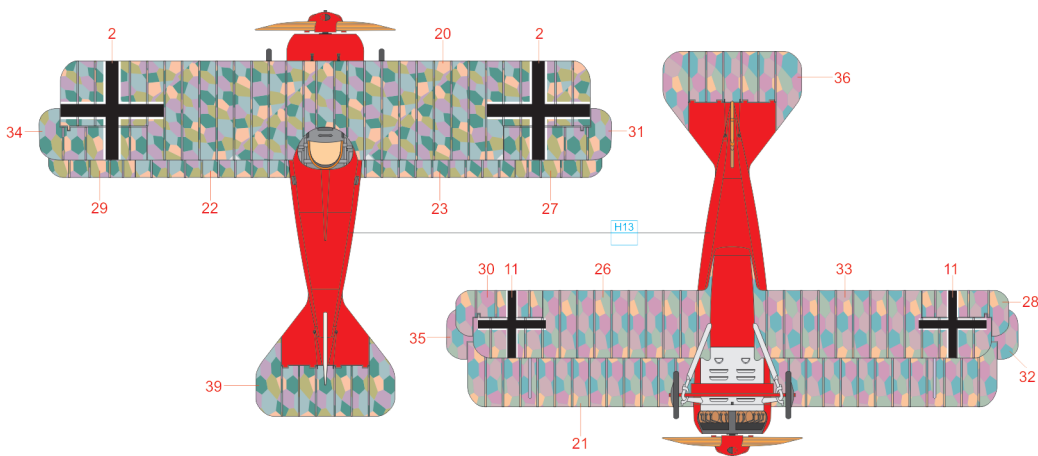

RED H13

WHITE H11 C62

WOOD BROWN H37 C43

ALUMINIUM MC218

NEUTRAL GRAY H53 C13

eduard

B SSW D.III 1618/18, Jasta 85 (Kest 5), Lt. Heinrich Dembowsky, Schaffhausen, November 13, 1918

Two days after the cease of hostilities, seven Jasta 85 (formerly Kest 5) aircraft landed in Switzerland. The pilot of the illustrated aircraft overshot the runway, went through a perimeter fence, and nosed the aircraft over. The insignia on the side of the plane helps to identify the pilot. The intertwined letters FWR and the Roman numeral 'I' in its lower part identify the pilot as being Grenadier-Regiment König Friedrich Wilhelm I (2nd Ostpreussisches) Nr.3. The only pilot from the Schaffhausen that landed and came from Eastern Prussia was Lt. Heinrich Dembowsky, and so it is likely that he was the pilot of this aircraft.

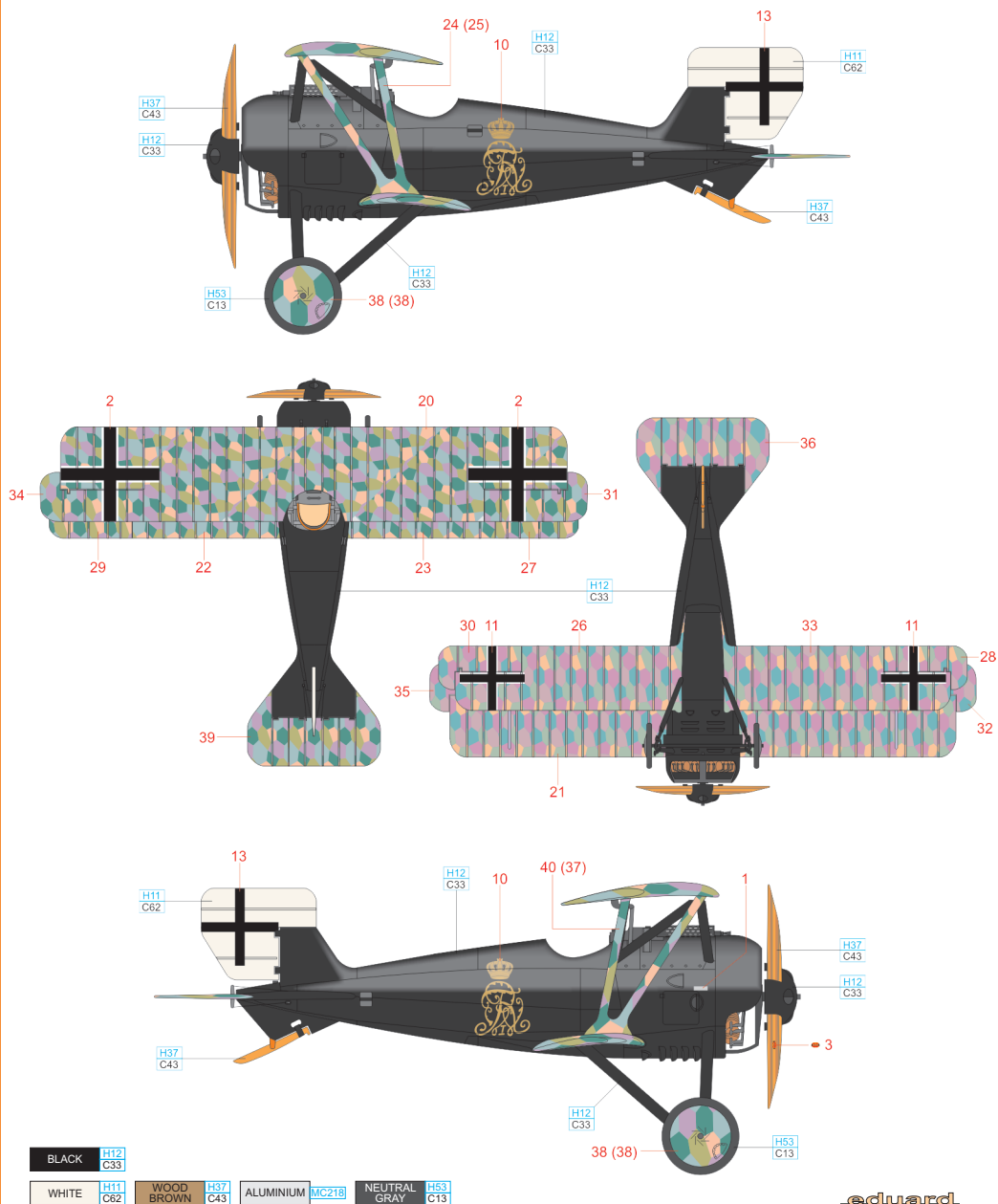

C SSW D.III, Jasta 15, Chery-les-Pouilly, July 1918

Siemens-Schuckert D.IIIs were tested at the Front in the spring of 1918, mostly by Jasta 15. In May, several pilots flying them gained kills, before the aircraft were sent back to the factory for modifications. After these mods were completed, they were returned to service, first and foremost to Kest units, where their excellent climb rate could be put to good use. Despite that, this modified aircraft managed to be photographed at the end of July in red-blue Jasta 15 colors at Chery-les-Pouilly. The handles were not a standard item.

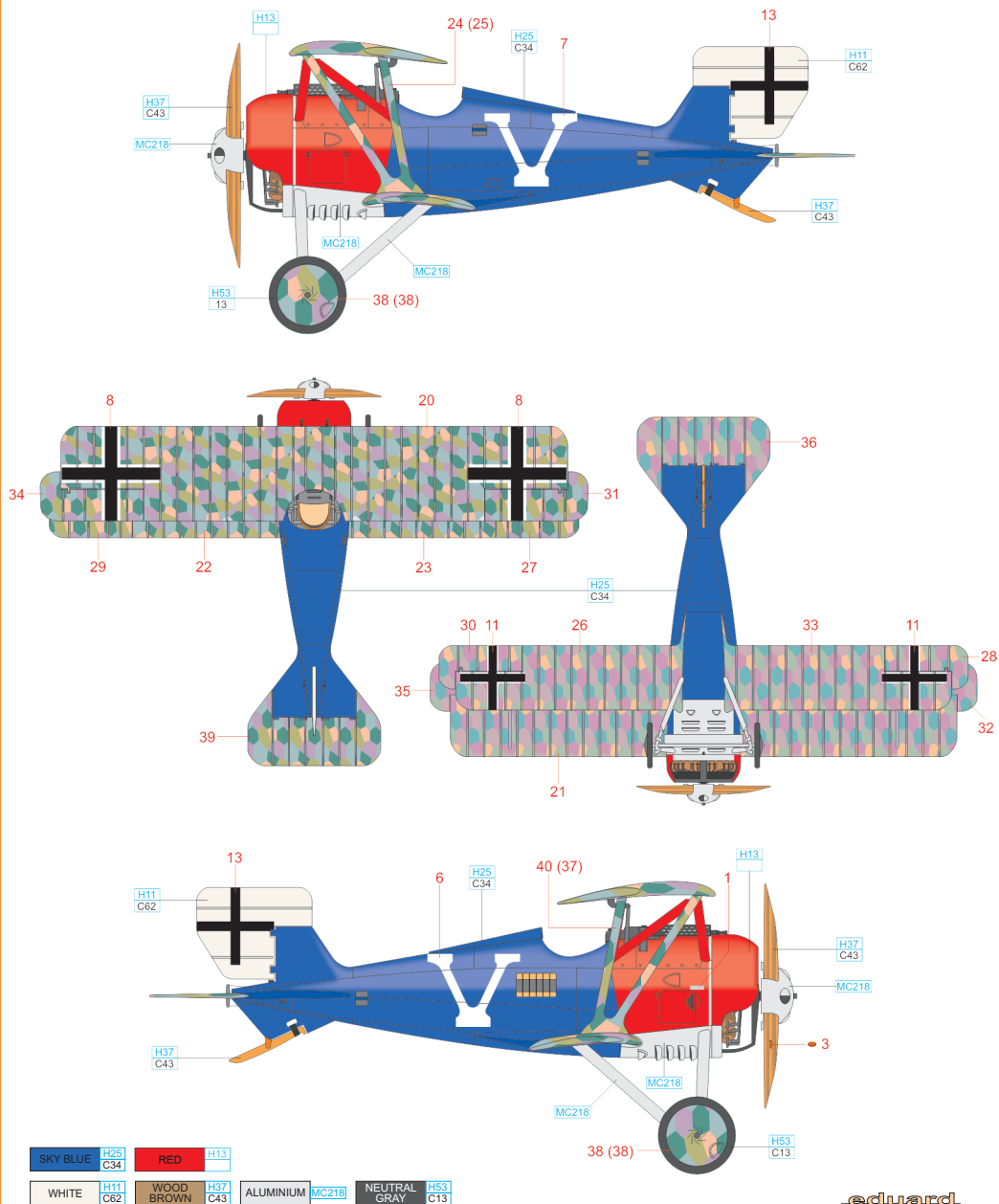

D SSW D.III 1626/18, Kest 4b, Vzfw. Reimann, September 1918

The SSW D.III was characterized by an excellent rate of climb. Front line units demanded speed and in the summer of 1918, that requirement was met by the Fokker D.VII. However, the SSW D.III's performance found favor among the air defense units - Kest. Their duty was to protect German assets from strategic bombardment. These attacks occurred at high altitudes, and the D.IIIs had a good chance to intercept and attack the bombers. The blue fuselage is one possible interpretation of the period black and white photograph, and brown is also possible.

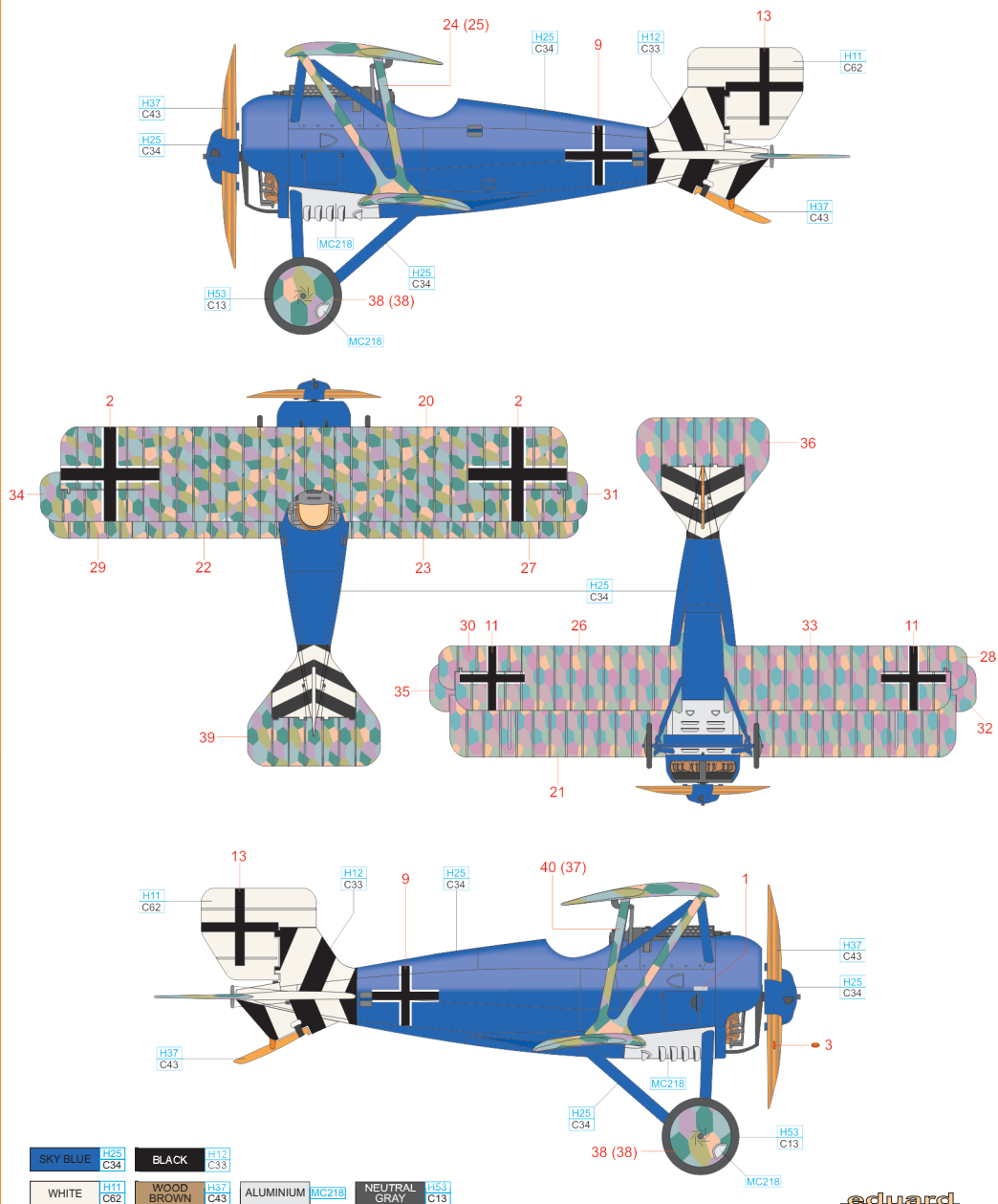

E SSW D.III 3025/18, Trier, December, 1918 to January 1919

This aircraft did not see much combat use. On November 8, 1918, it was assigned to Kest 4b. Three days later, the war ended, and the aircraft was handed over to the Americans, and was tested between 1918 and 1919 at Trevir. At the time, the aircraft still carried German national markings and full armament. There appeared a figure of a soldier on the wing strut.

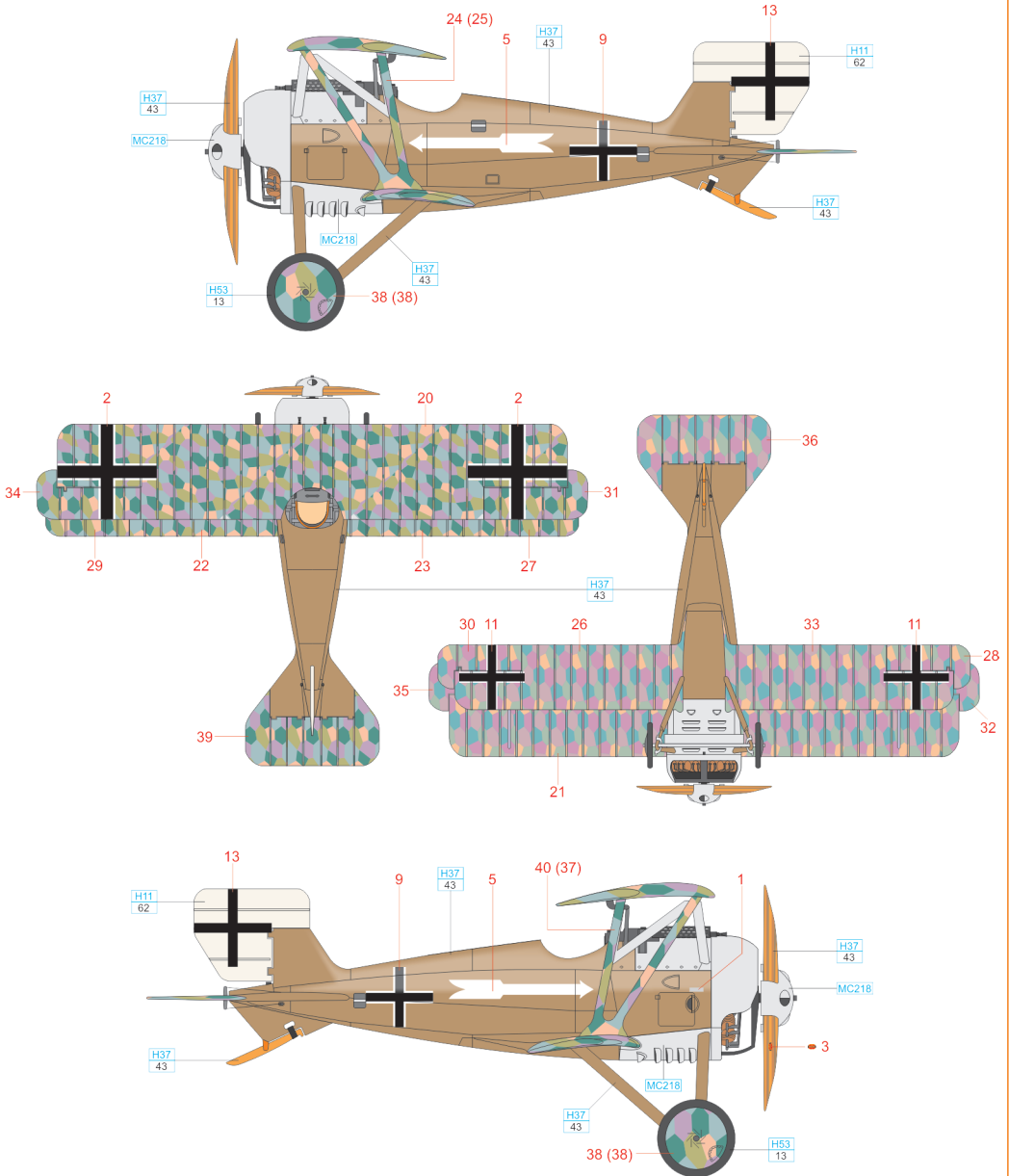

WHITE	H11 62	WOOD BROWN	H37 43	ALUMINIUM	MC218	NEUTRAL GRAY	H53 13
-------	-----------	------------	-----------	-----------	-------	--------------	-----------

RIB STRIPES - PORTY

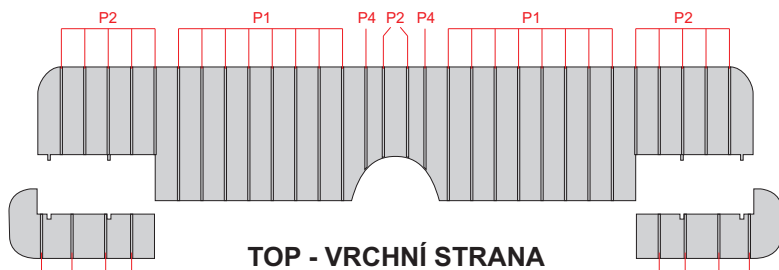

TOP - VRCHNÍ STRANA

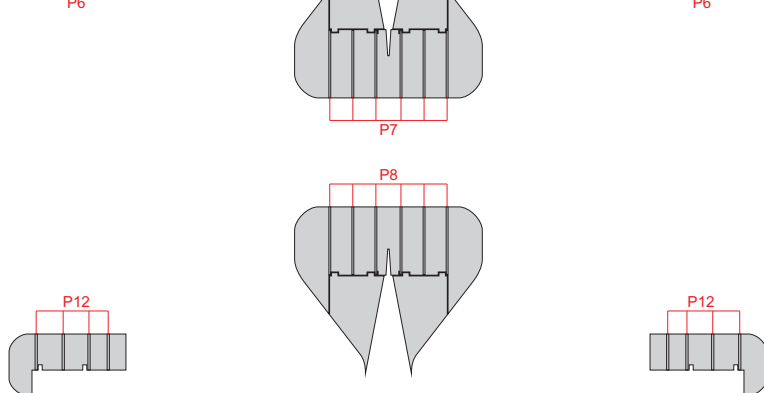
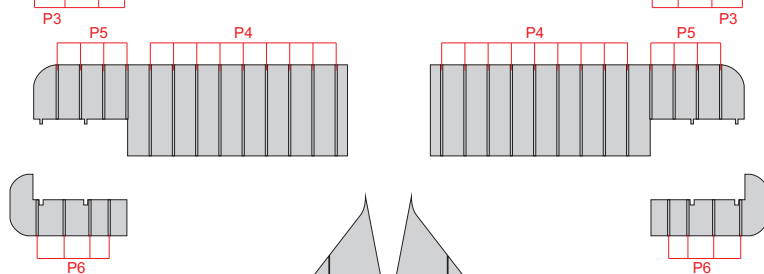

BOTTOM - SPODNÍ STRANA

