

HAWK

100 SERIES

ADVANCE JET TRAINER

ホーク 100 シリーズ



1/32 HAWK 100 SERIES

A British single engine, two-seat advanced jet trainer aircraft with updated avionics, an optional forward looking infrared, a redesigned wing and a hands-on-throttle-and-stick (HOTAS). The Hawk has been used in a training capacity and as a low-cost combat aircraft.

In 1997 the Hawk was selected for use in a joint venture between the Canadian Government and Bombardier Aerospace Corporation, offering its services to friendly governments on a contract basis under the aegis of the 'NATO Flying Training in Canada (NFTC)' program. 18 Hawk 115 trainers were initially ordered for NFTC, with another 3 ordered in 2000 when Singapore signed up for the program.

The Royal Australian Air Force ordered 33 Hawk 127 Lead-in Fighter Trainers (LIFTs) for its advanced fighter trainer requirement in 1997, 12 of which were produced in the UK and 21 in Australia.

With the arrival of the Eurofighter Typhoon and in future the Joint Combat Aircraft, the RAF needed a new training vehicle to replicate the more complex flying systems of these new generation aircraft. Enter the Hawk 128 which was selected as the new Advanced Jet Trainer (AJT) for the UK Armed Forces in 2003.

FADEC デジタル制御装置装備のイギリス製 ロールス ロイス アドヴァンス Mk.951 ターボファン エンジン 1 基に、主翼デザインを一新したコンパクト ウィング スロットル・電子装備・各種搭載兵装などの各種スイッチを手を離すことなく操作可能な HOTAS 操縦桿に加え、オプションで前方監視赤外線暗視装置も搭載可能であるなど、最新の航空技術を結集した「ホーク」は、低コストで運用可能な最新鋭 ジェット練習/攻撃機です。

1997年、NFTC(カナダ/NATO軍飛行訓練)プログラムに基づく協定により、加盟国政府にその配備が提案されるに伴い、カナダ政府とボンバルディア エアロスペース社の合併に於いて「ホーク」の運用が決定されました。また、シンガポールが NFTC に調印した際には、初回の 18 機に続いて、2000 年には 3 機の「ホーク 115 練習機」が調達され、高等戦闘/練習機の導入のために 1997 年にオーストラリア空軍によって発注された「ホーク 127 LIFT 戦闘機導入練習機」33 機のうち、12 機はイギリスで 21 機はオーストラリアで製造されました。そしてユーロファイター タイフーンや F-35 ライトニング II の導入に伴い、これら第 4.5 および 5 世代戦闘機のより高度な飛行性能を再現するためイギリス空軍が新しい訓練機材を必要とした結果、2003 年イギリス軍は次期高等練習機に「ホーク 128」の導入を決定しました。



Drill



Remove



2 Set



Bend



Optional



Decal



Super Glue



Fill Hole



No Cement



Be Careful

TOOLS RECOMMENDED

Cement

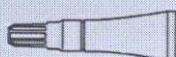

Side Cutter



Modeling Knife



Tweezers

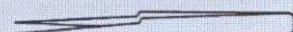

⚠ CAUTION

- *Read carefully and fully understand the instructions before commencing assembly.
- *Keep out of reach of children. Children must not be allowed to put any parts in their mouths, or pull plastic bag over their heads.
- *When using adhesives and paints, please make sure not to use them in closed room or near the fire.
- *When assembling this kit, tools including knives are used. Extra care should be taken to avoid injury.

WARNING: CONTAIN SMALL PARTS NOT FOR CHILDREN UNDER 14 YEARS OF AGE.

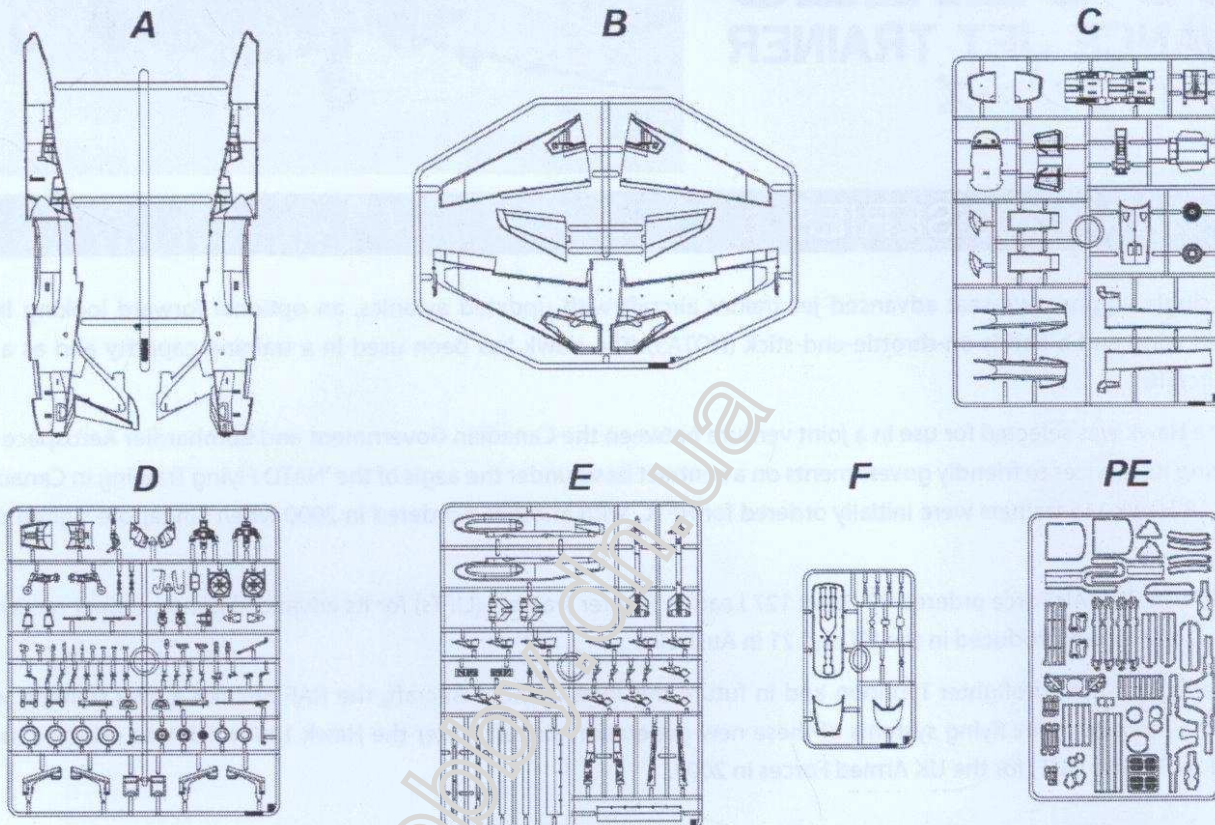

AFTERMARKET SERVICES CARD

When requesting replacement parts, please take or send this form to your local dealer so that the parts required can be correctly identified. Please note that specifications and availability are subject to change without notice.

For more information, please contact services@kineticmodel.com or visit <http://www.kineticmodel.com> for latest information.

| Parts Code | | Item 48038 |
|-------------|--------|------------------------------|
| 00-128-001 | A | 1/32 HAWK FUESLAGE |
| 00-128-002 | B | 1/32 HAWK WINGS |
| 00-128-003 | C | 1/32 COCKPIT, INTAKE |
| 00-128-004 | D | 1/32 SEAT, LANDING GEAR |
| 00-128-005 | E | 1/32 FLAPS, MISSILE LAUNCHER |
| 00-128-006 | F | 1/32 HAWK CANOPY |
| 01-128-3206 | DECAL | 1/32 HAWK-128 |
| 03-128-3206 | MANUAL | |
| 06-128-3206 | PE | 1/35 HAWK 100 PE SET |

PAINT INDEX

| COLOR | VALLEJO MODEL COLOR | MODEL AIR | GSI CREOS MR. COLOR | ITALERI ARCYLICPAINT |
|-----------------------------|------------------------|-----------|------------------------|-------------------------|
| FLAT BLACK | 950 | 057 | 33 | 4768AP |
| GLOSS WHITE | 951 | 001 | 1 | 4796AP |
| CLEAR RED | 934 | - | 47 | - |
| LIGHT GHOST GREY (FS36375) | 154 | - | 308 | 4762AP |
| GLOSS DARK BLUE (FS15044) | 930 | - | 326 | - |
| RAF AIRCRAFT GREY (FS36440) | 986 | - | 332 | - |
| GLOSS BLACK (FS17038) | 170 | - | 2 | 4769AP |
| METALLIC GRAY | 179 | - | 78 | 4766AP |
| FOUNDATION WHITE | 919 | - | 69 | - |
| ALUMINIUM | 178 | - | - | - |
| BLUE GREY (FS35237) | 49 | - | 337 | 4762AP |

* 950 denotes Vallejo Model Color

1

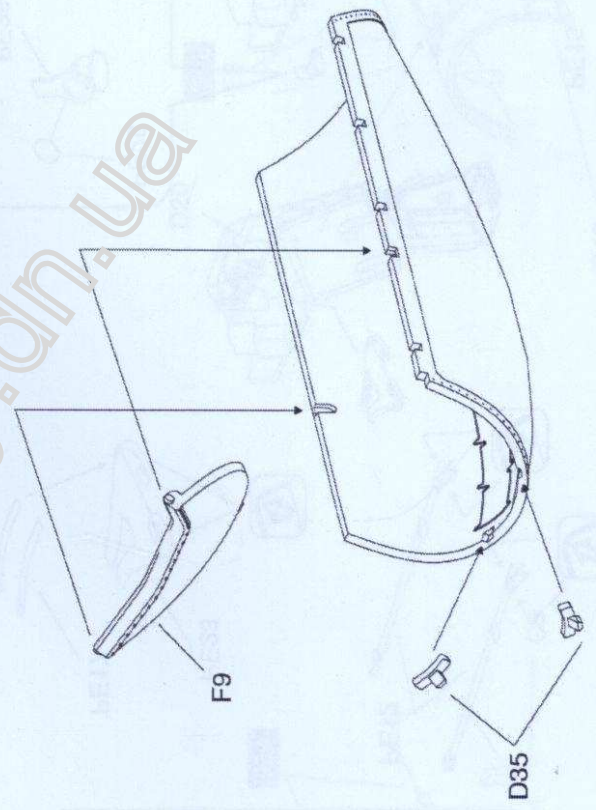
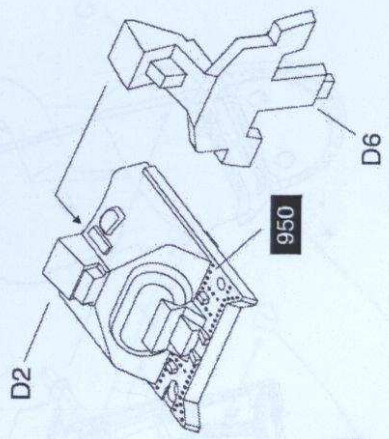
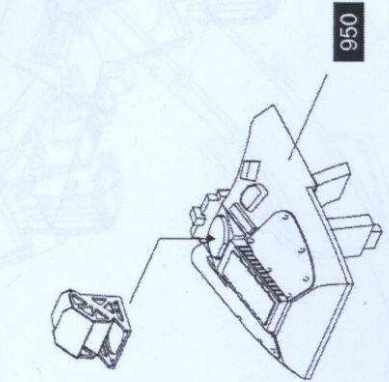
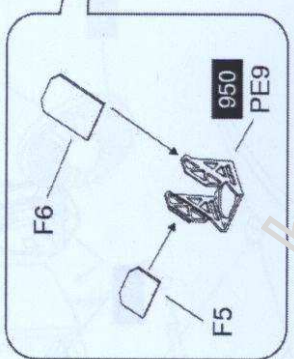
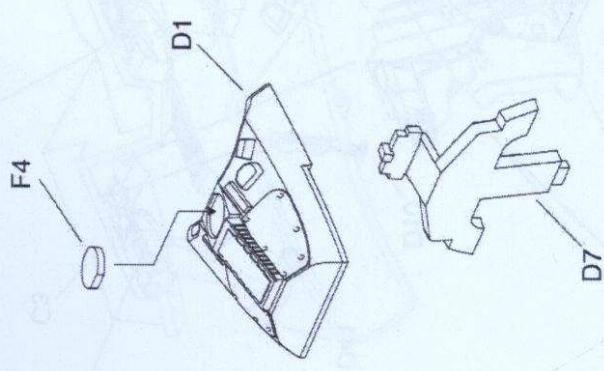

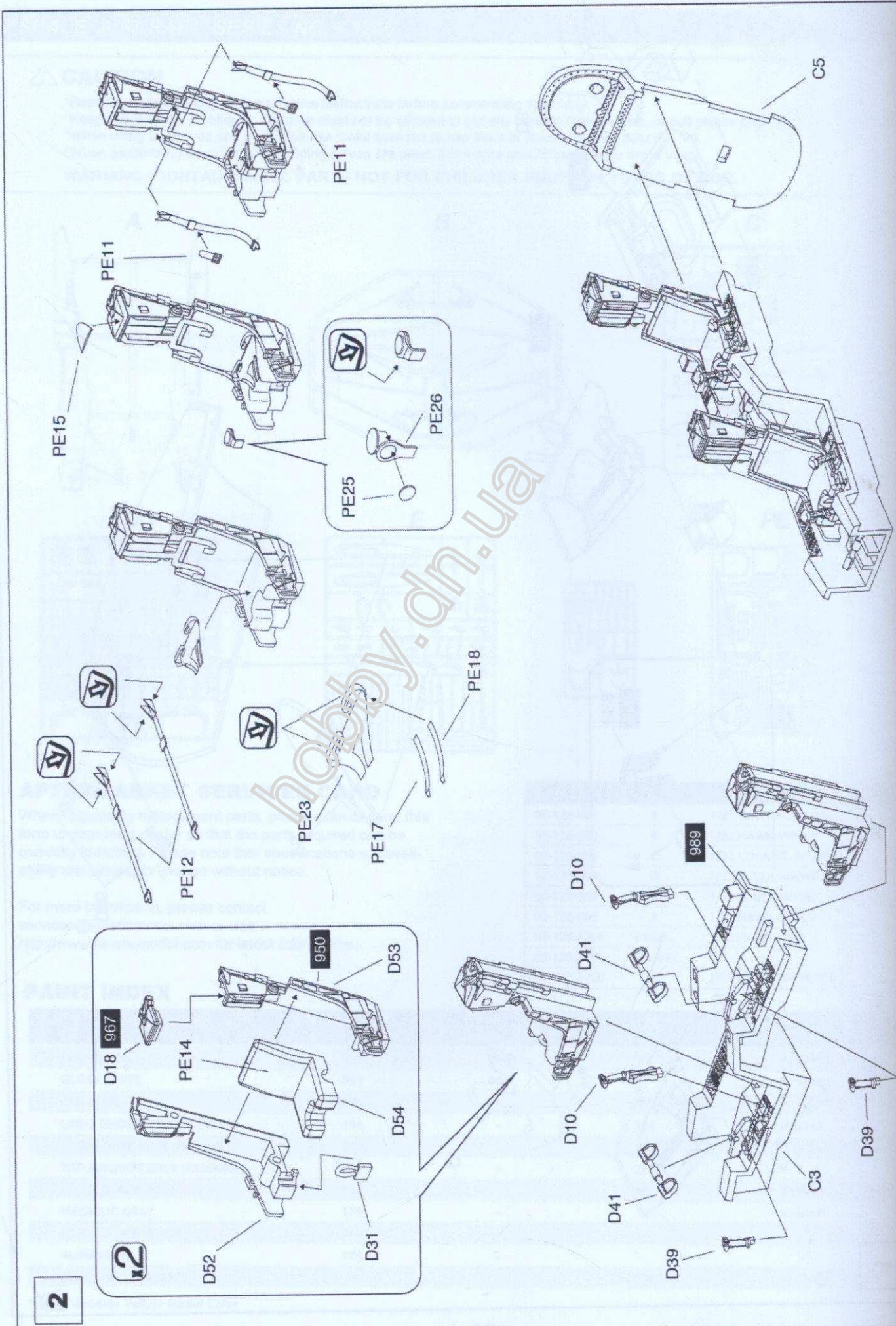

2

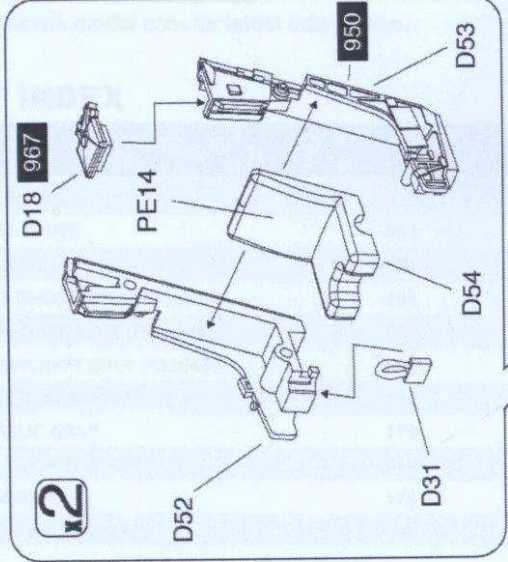

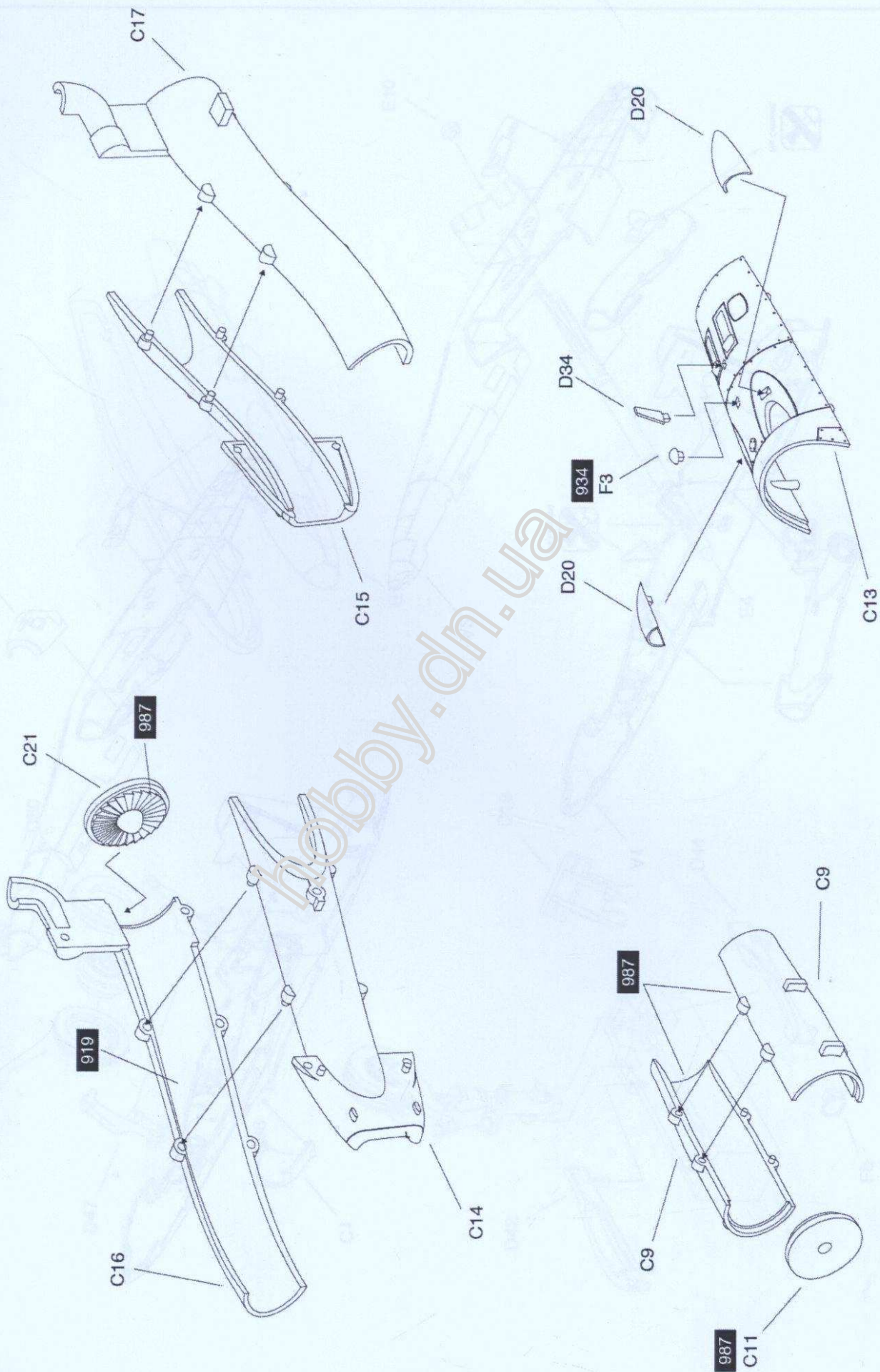

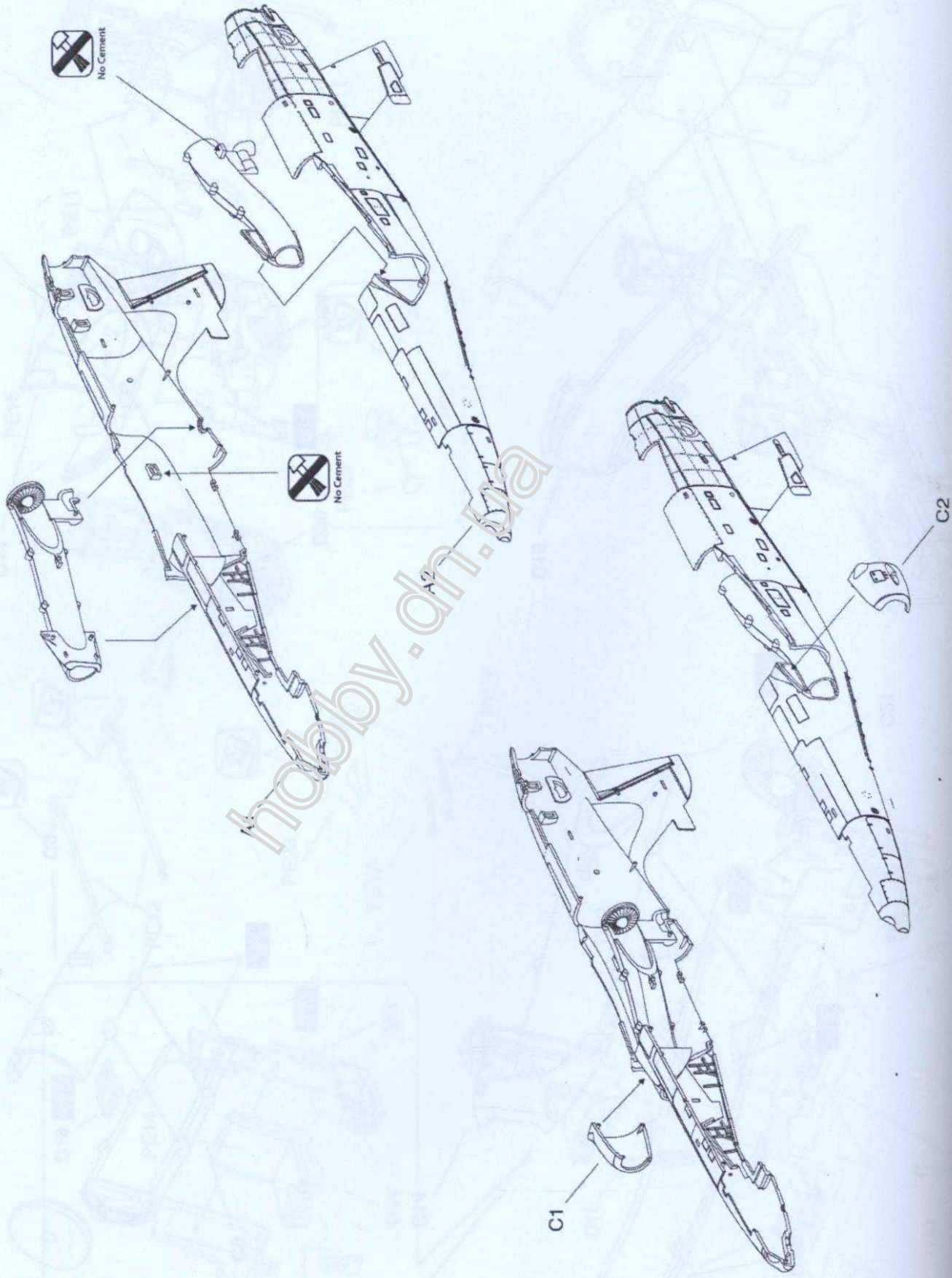

5

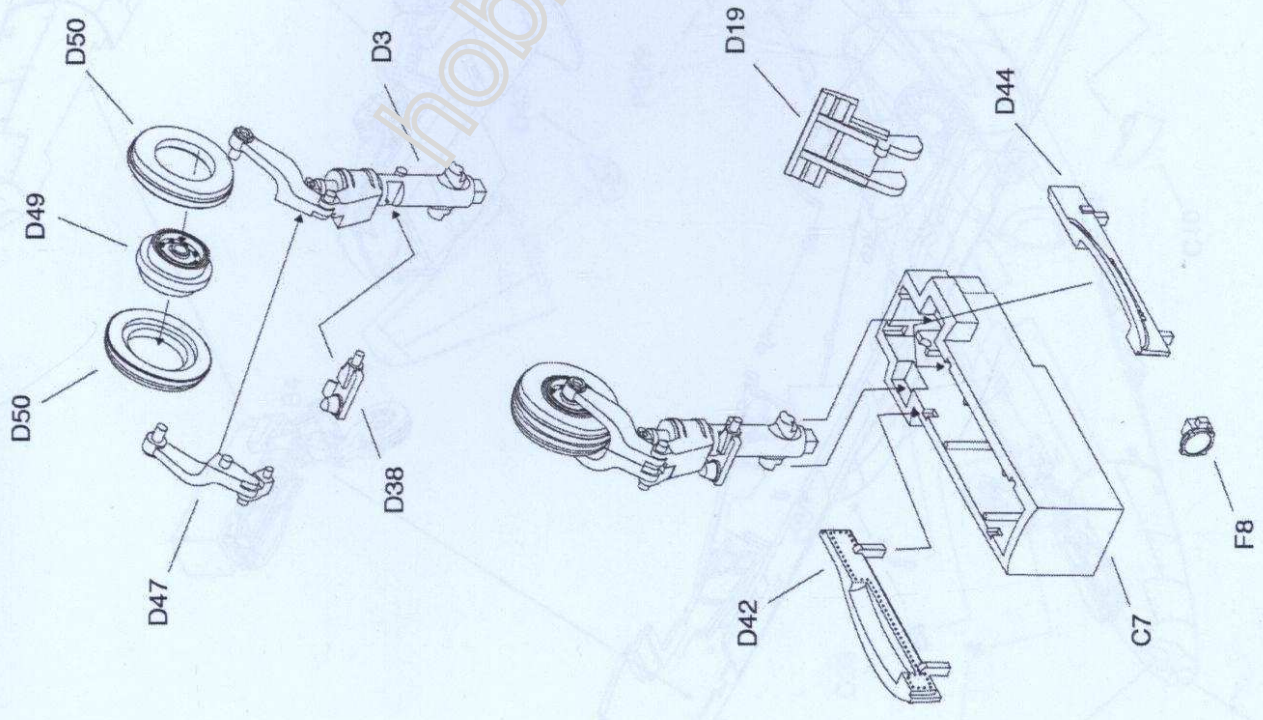

6

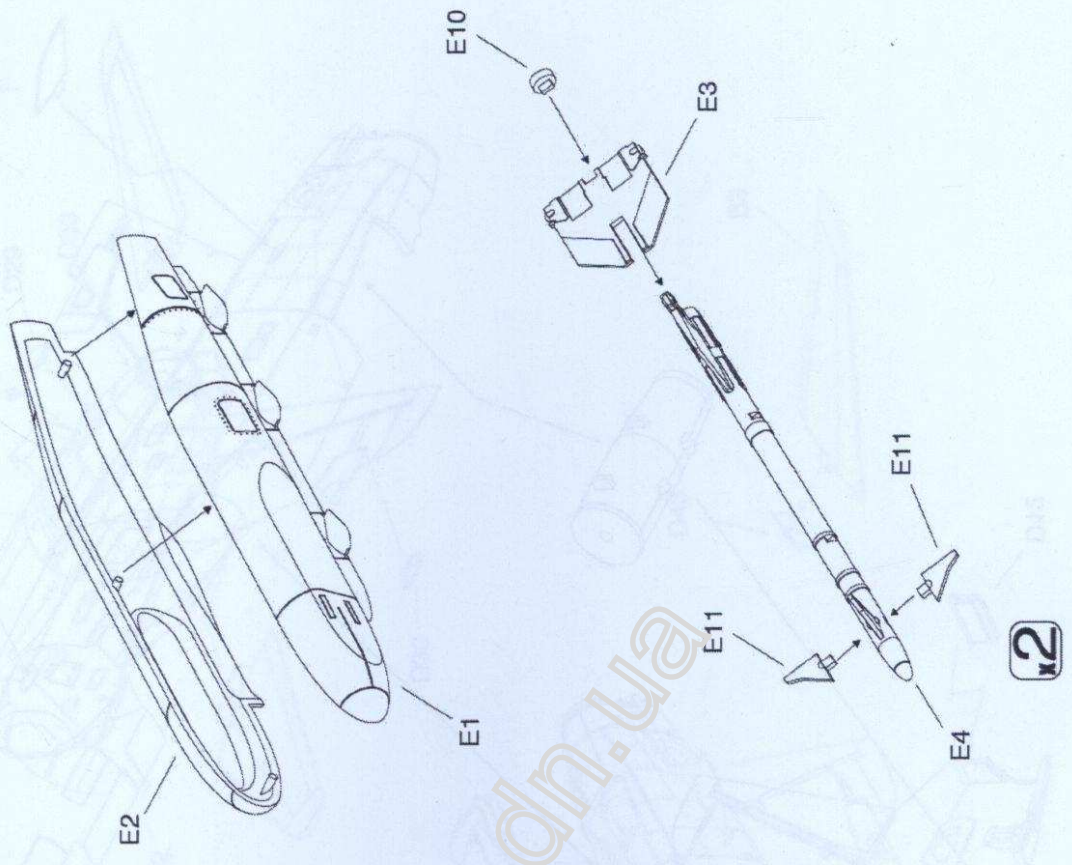

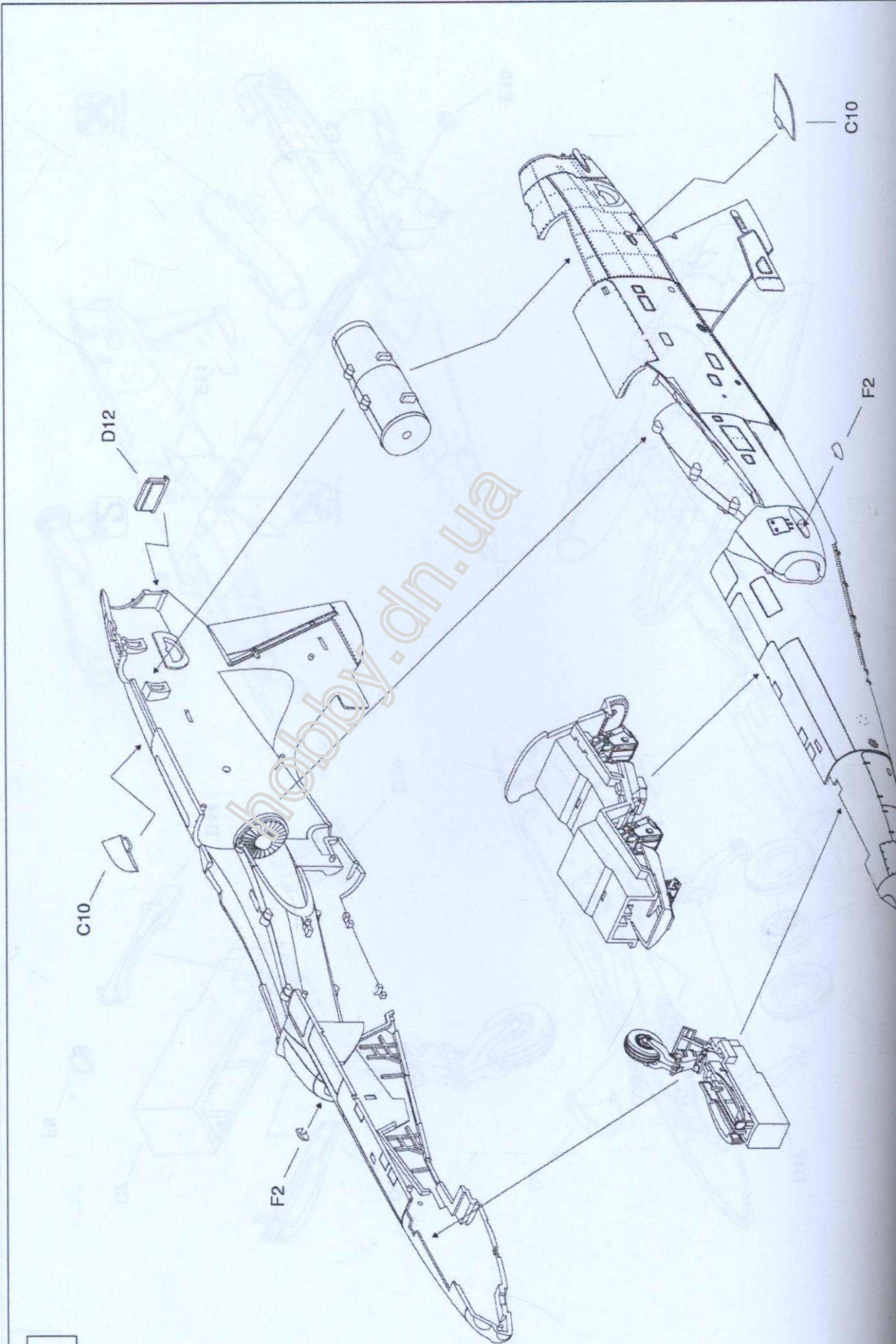

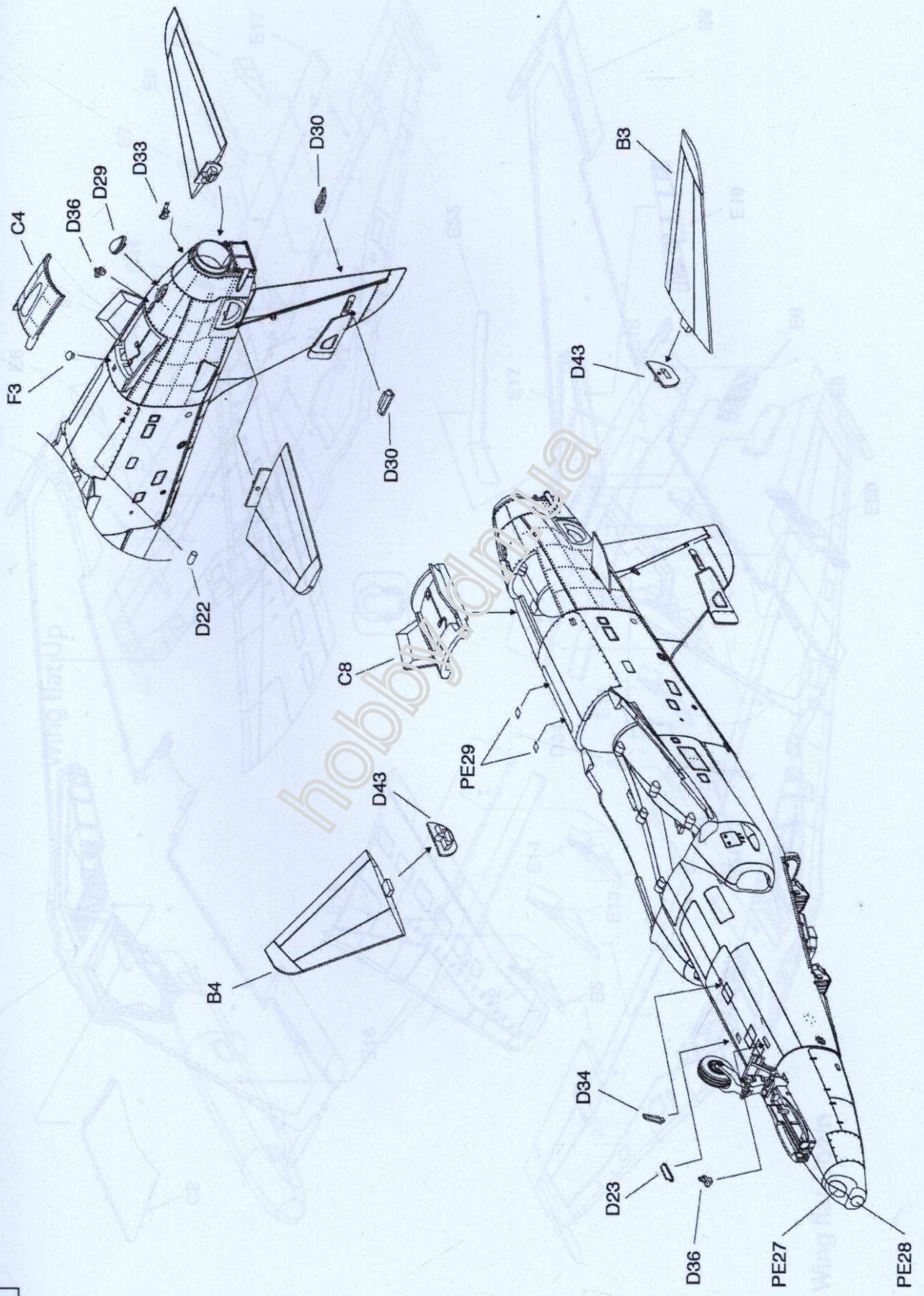

8

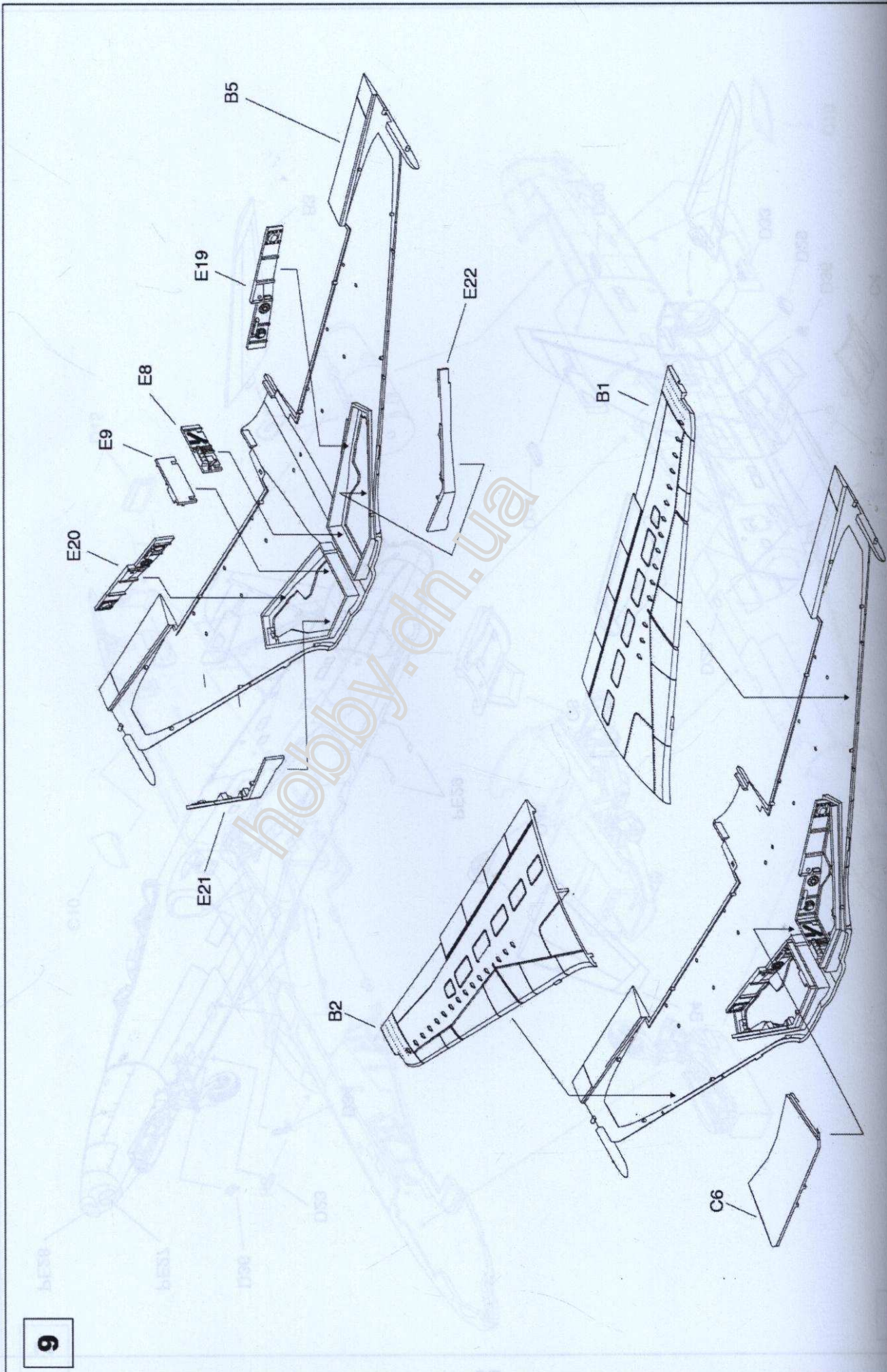

Wing flat Up

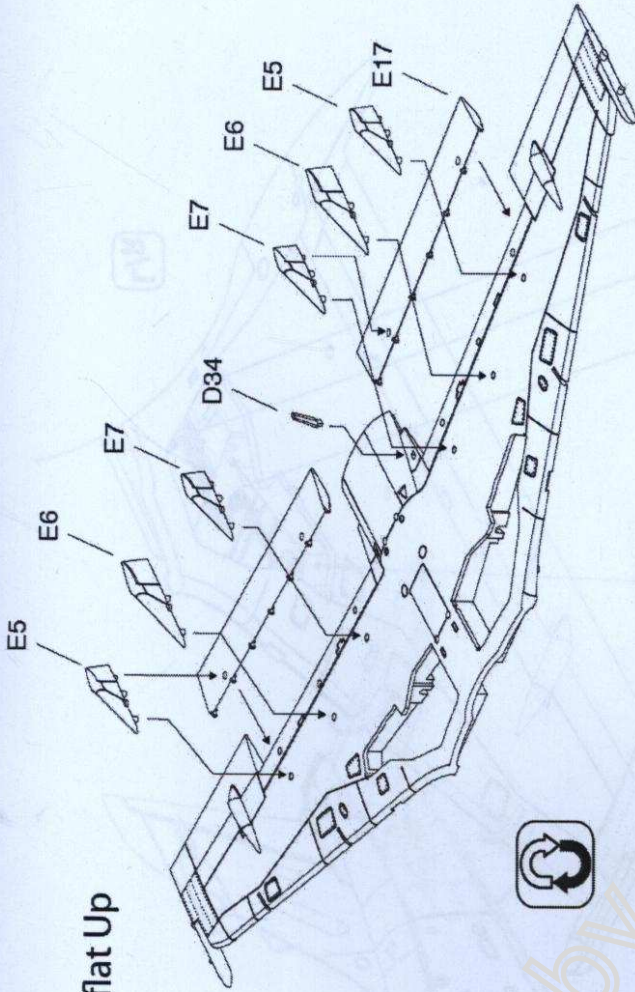

Wing flat Down

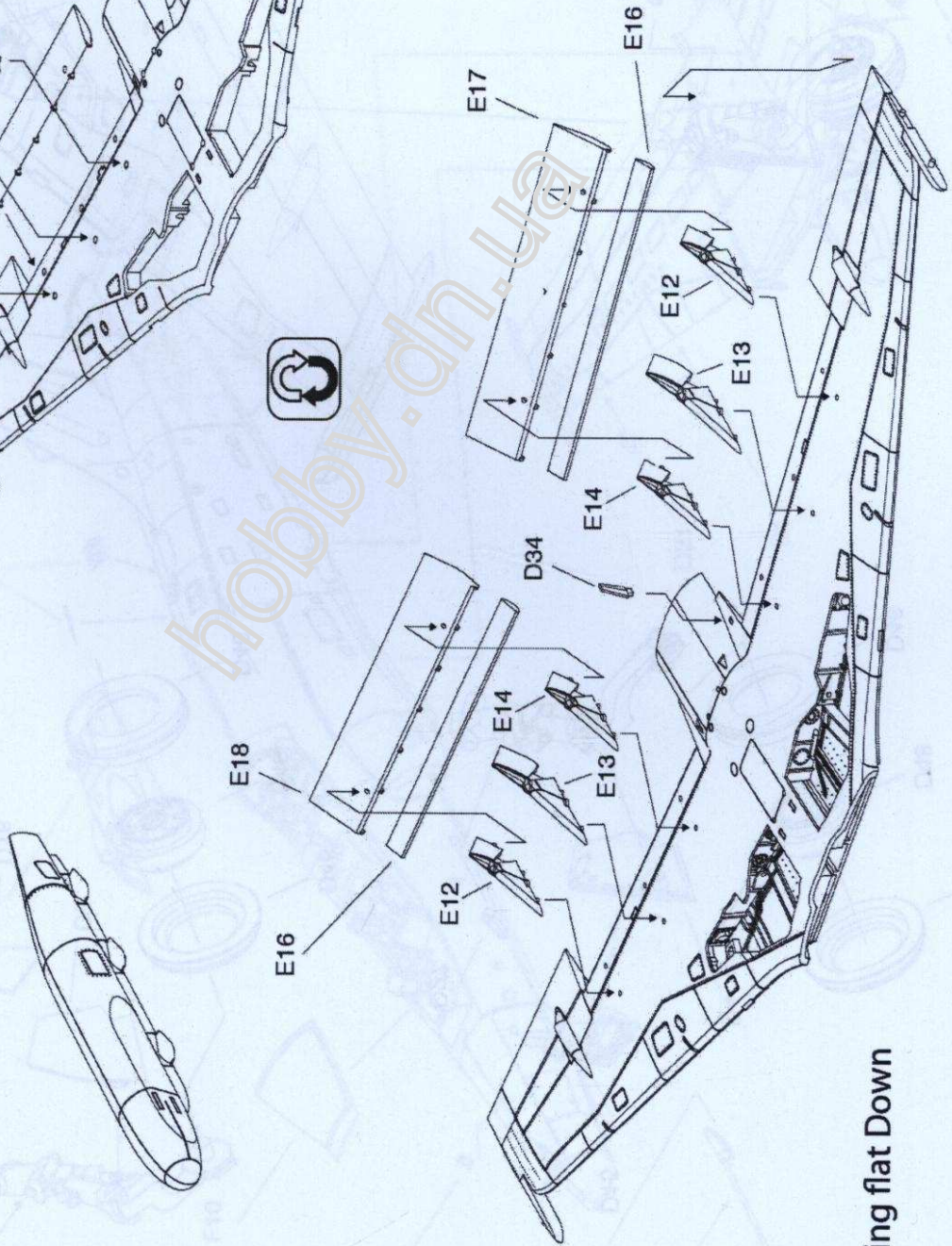

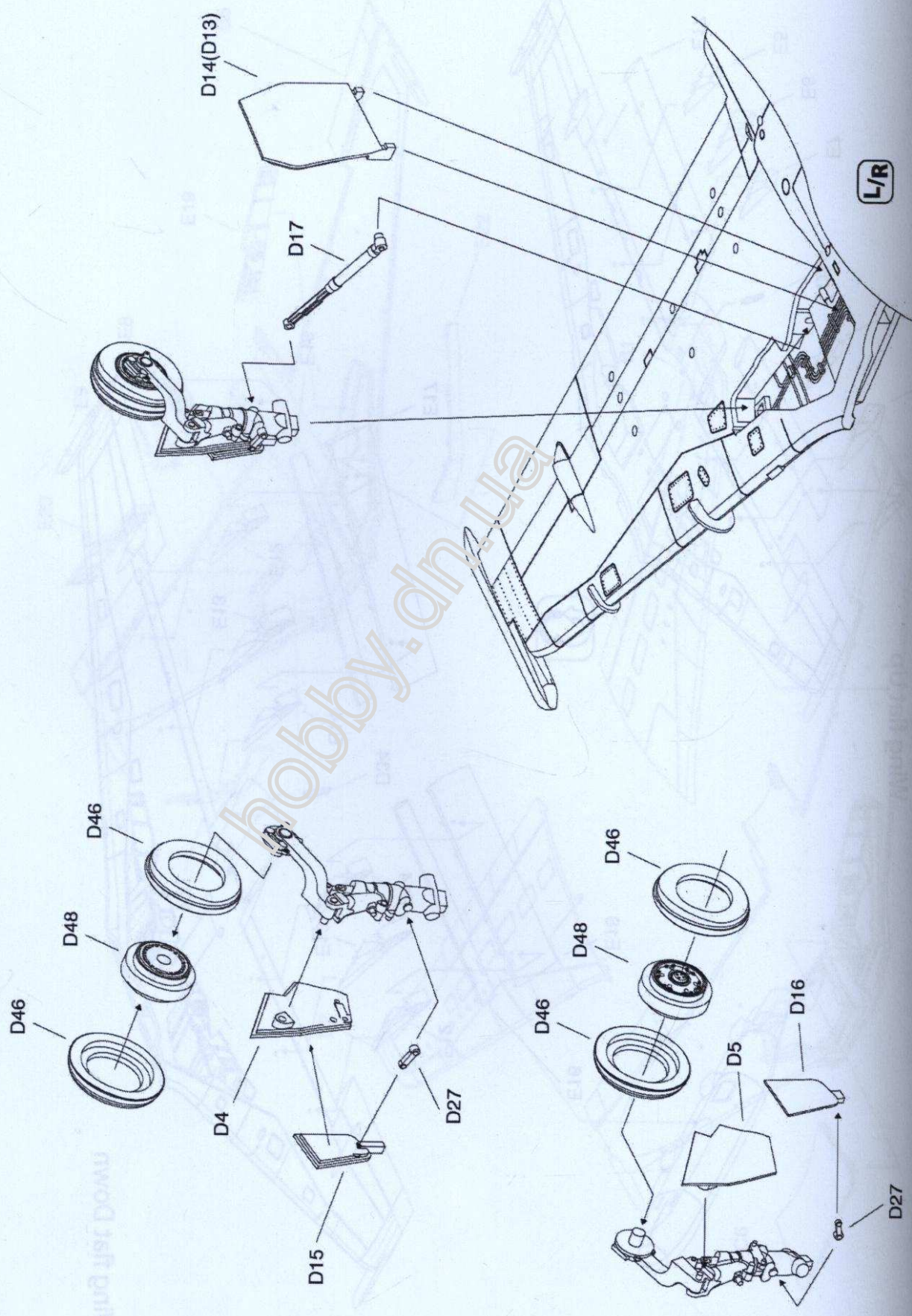

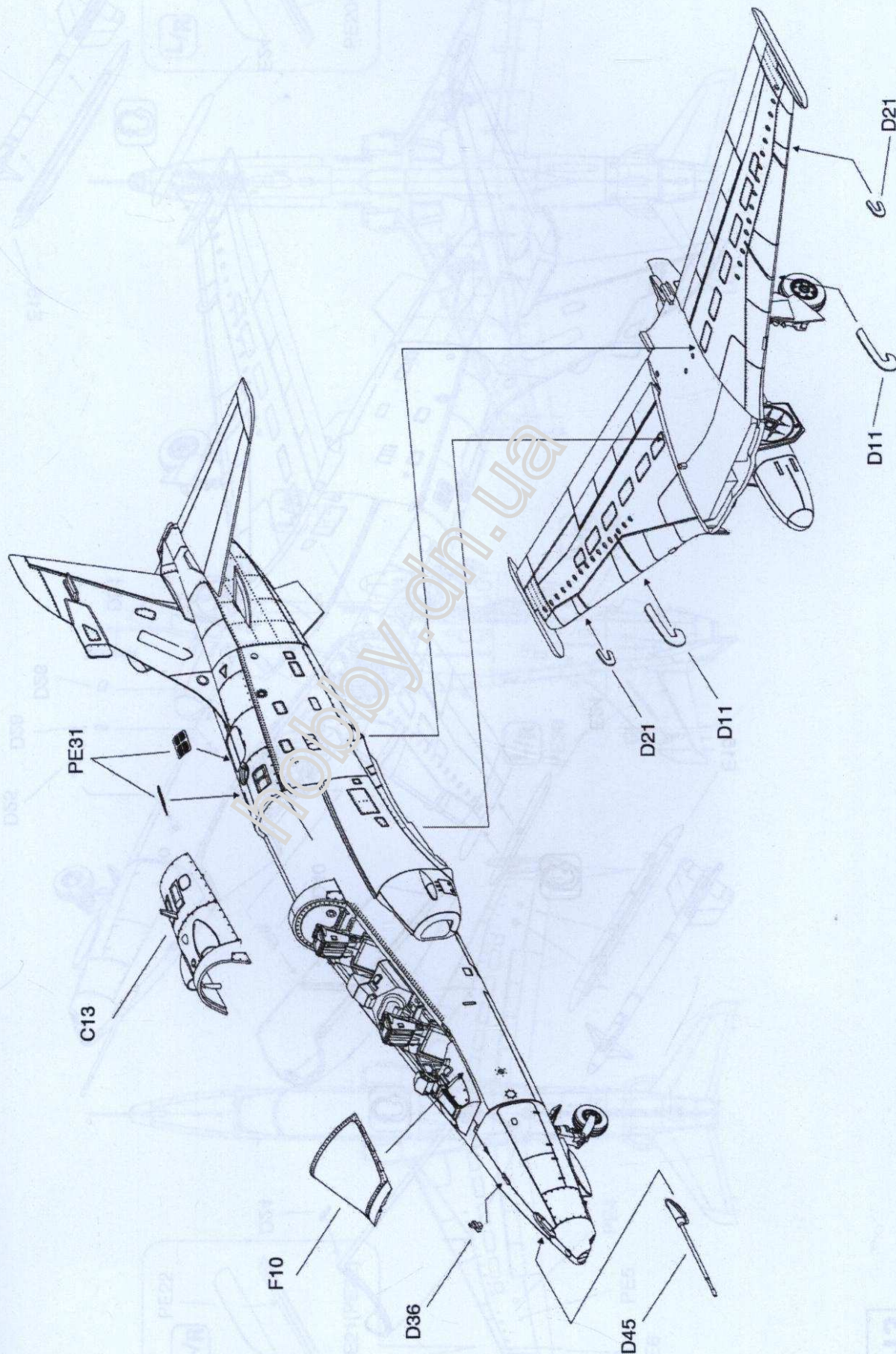

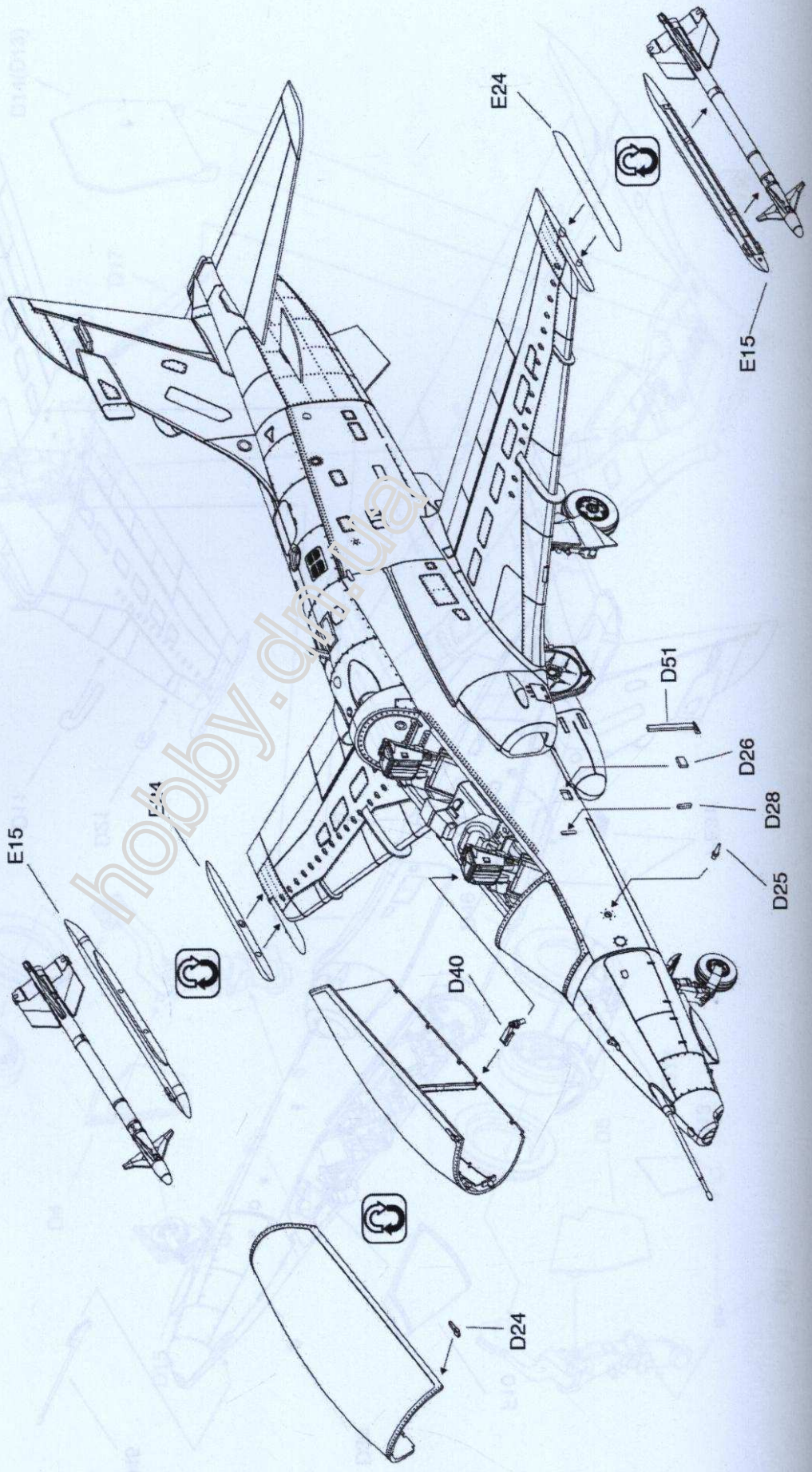



PE22
L/R
PE21(PE22)

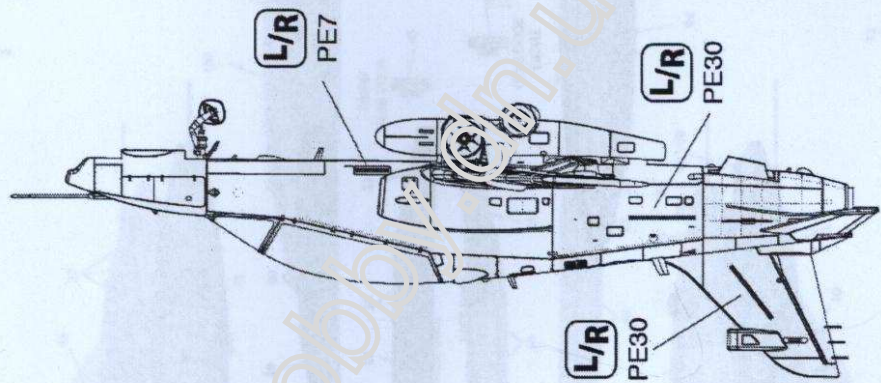
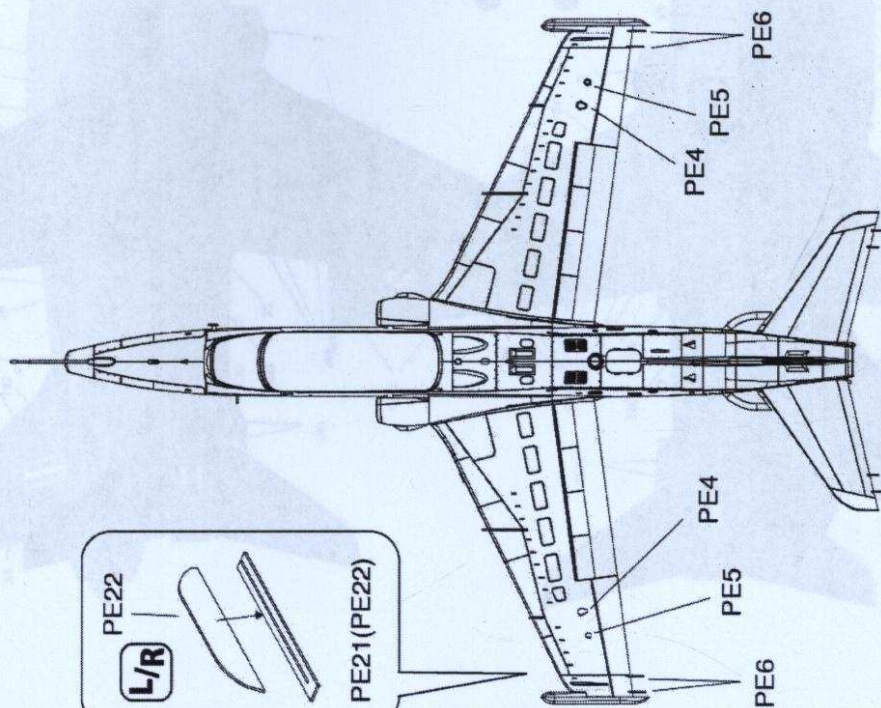



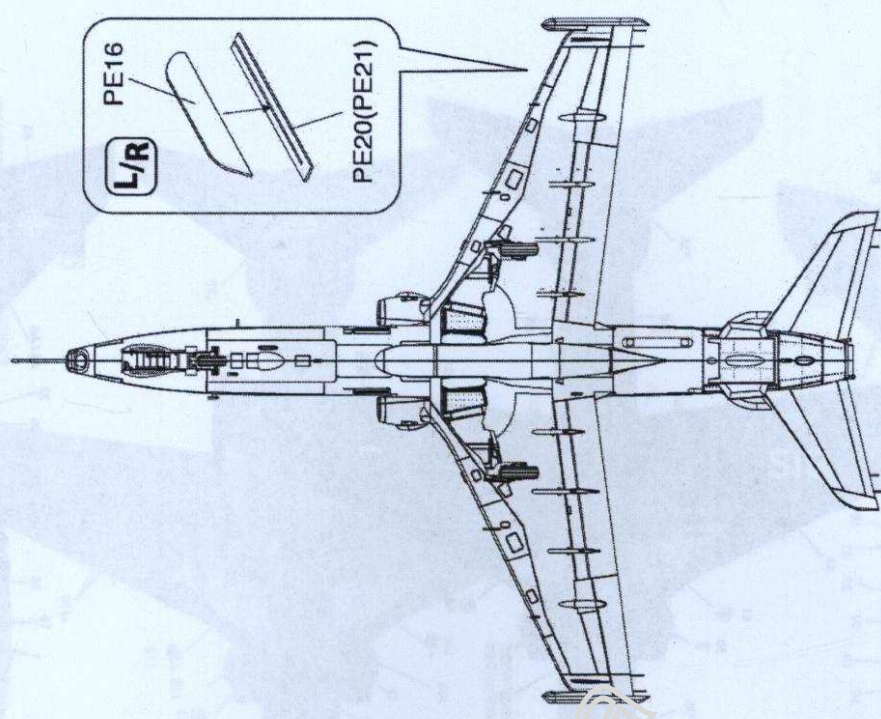

PE16
L/R
PE20(PE21)

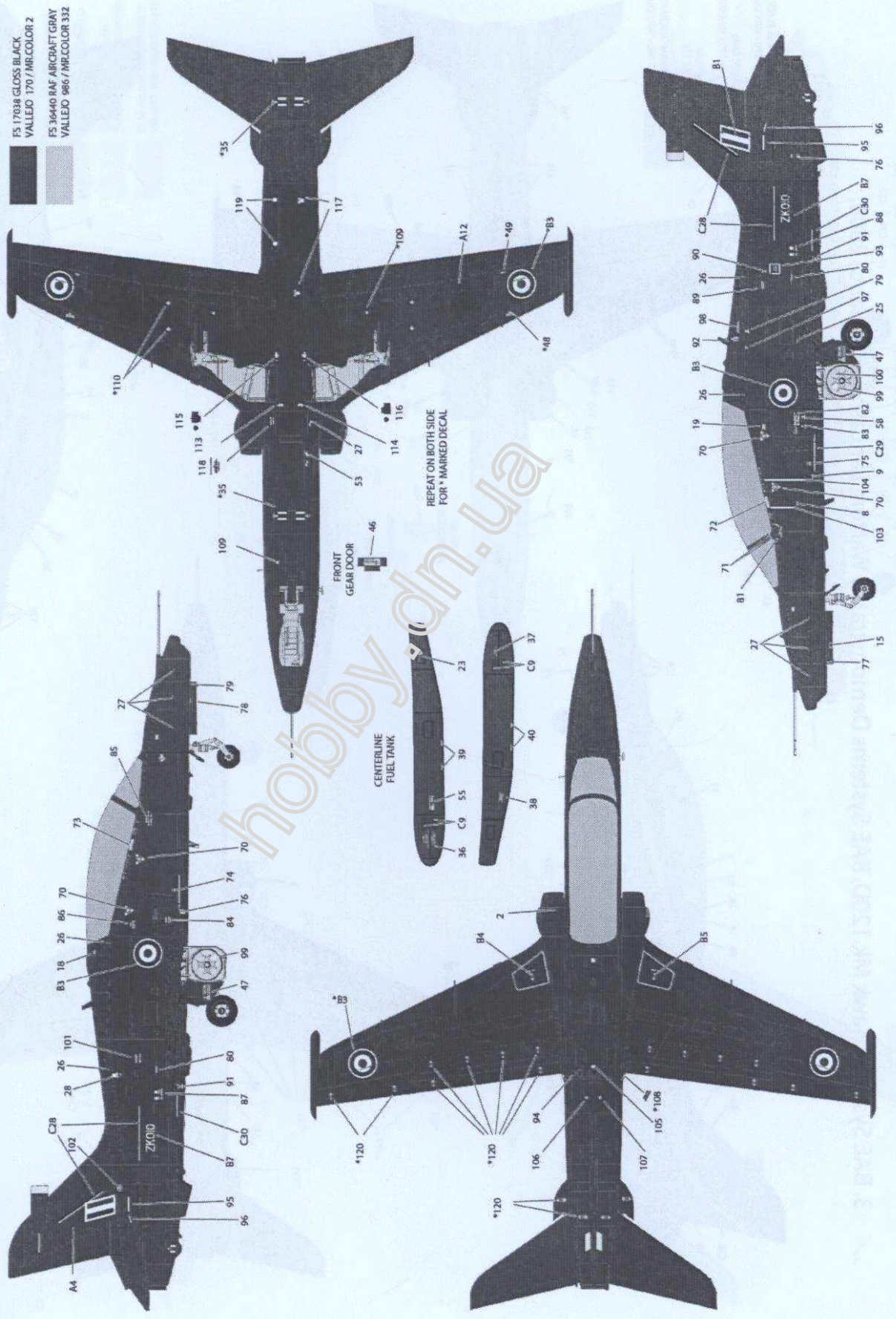

2. BAE Systems Hawk Mk.128, BAE Systems Warton, Lancashire, England, 2008.



3. BAE Systems Hawk Mk.120D, BAE Systems Demonstrator, Warton, Lancashire, England, 2008.

| | |
|---|--|
|  | FS 17098 GLOSS BLACK VALLEJO 170 / MR.COLOR 2 |
|  | METALLIC GRAY VALLEJO 179 / MR.COLOR 78 |
|  | ALUMINIUM VALLEJO 178 |
|  | FS 36440 RAF AIRCRAFT GRAY VALLEJO 986 / MR.COLOR 332 |

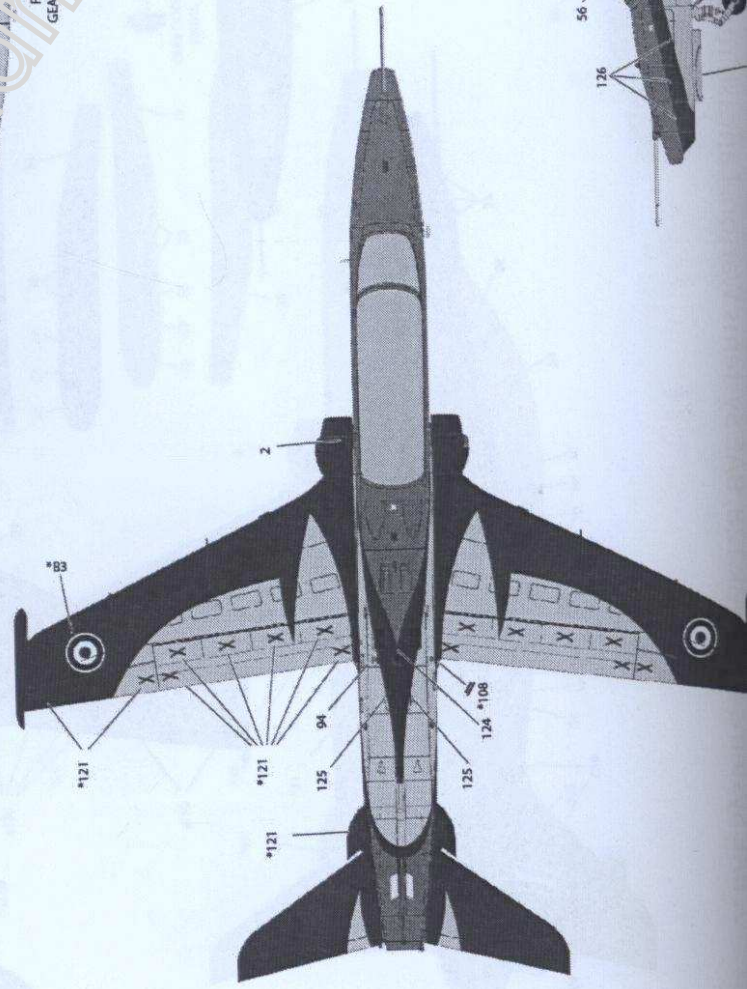
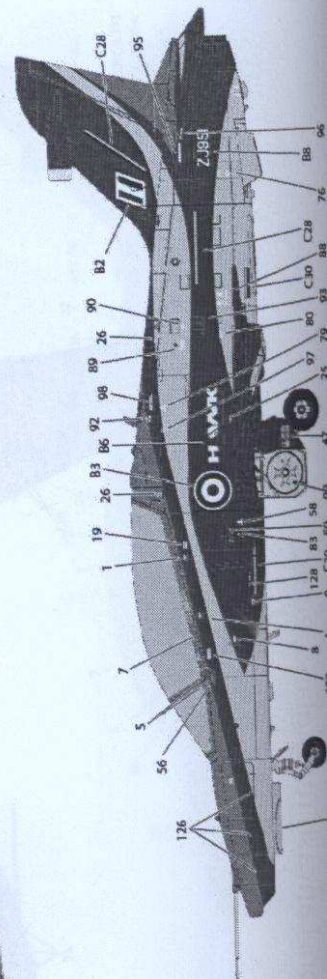
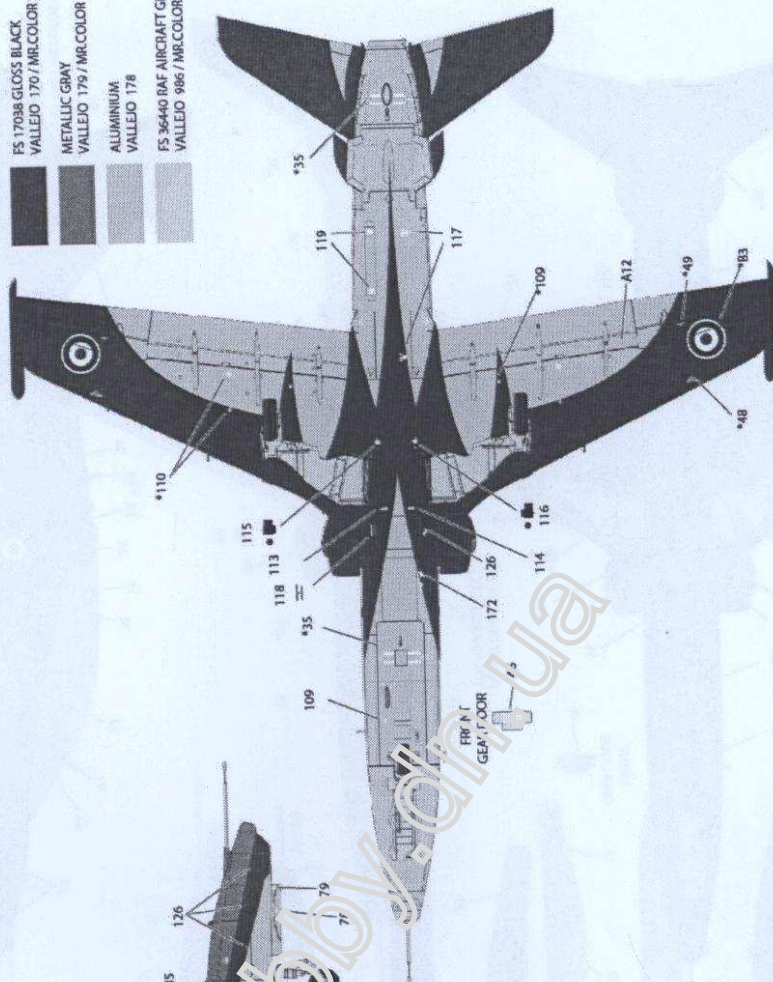

hobbyonline.ua

4. BAE Systems Hawk Mk.127, No. 76 Squadron's special scheme.
 Royal Australian Air Force, Williamtown, New South Wales, 2003.

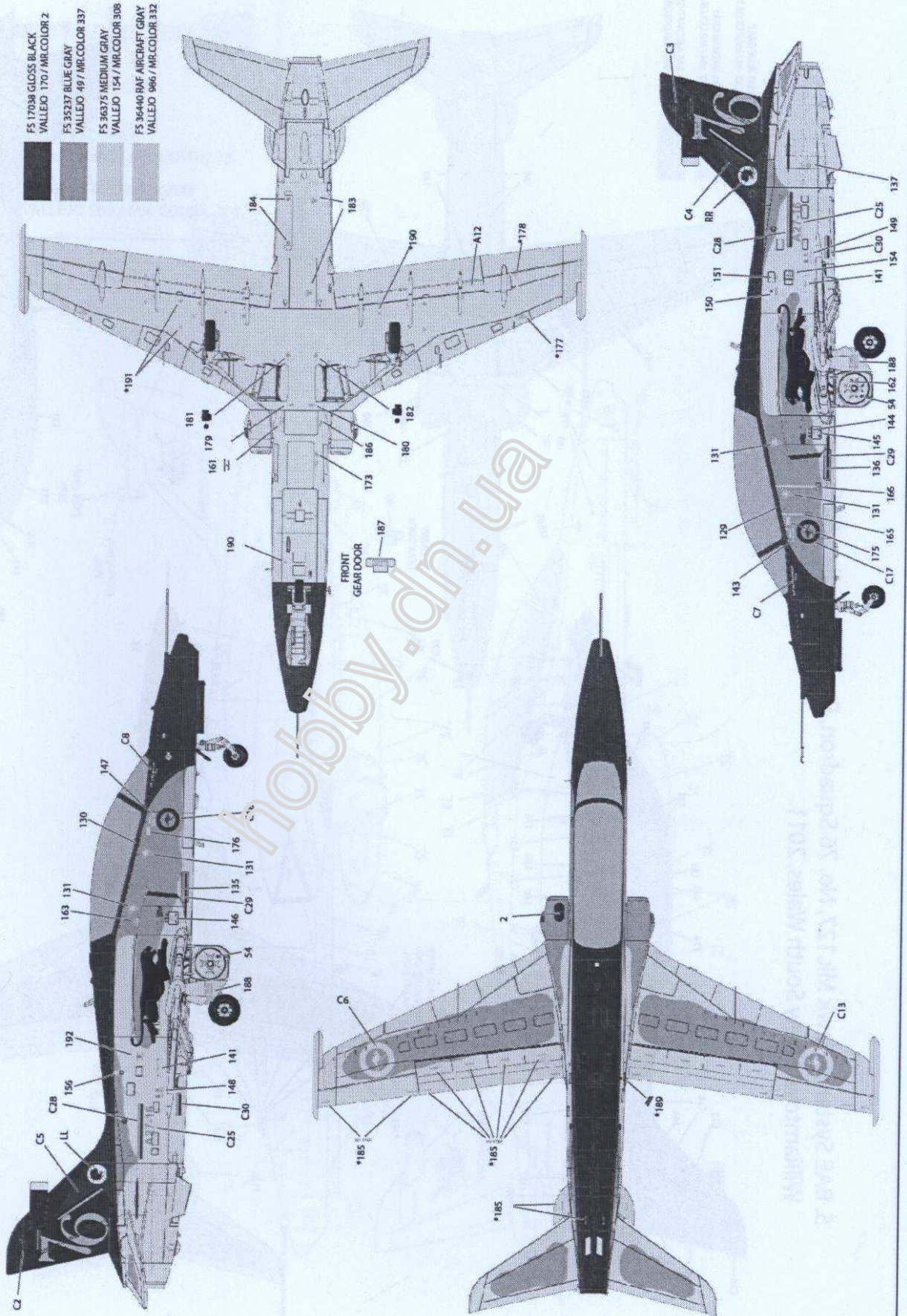

5. BAE Systems Hawk Mk.127, No. 76 Squadron, Royal Australian Air Force, Williamstown, New South Wales, 2011.

- FS 35237 BLUE GRAY
VALLEJO 49 / MR.COLOR 337
- FS 36375 MEDIUM GRAY
VALLEJO 154 / MR.COLOR 308
- FS 36440 RAF AIRCRAFT GRAY
VALLEJO 986 / MR.COLOR 332

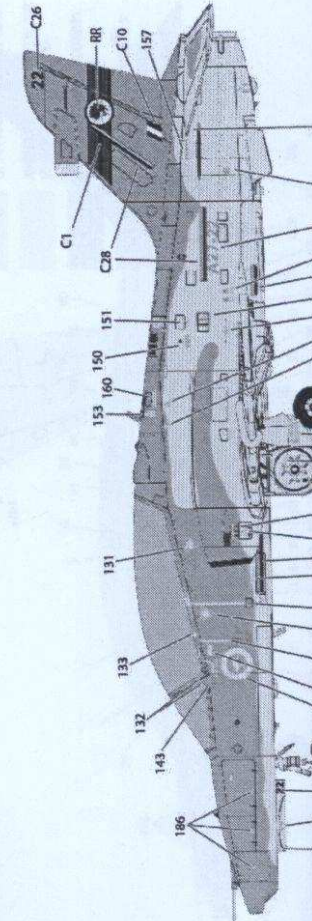
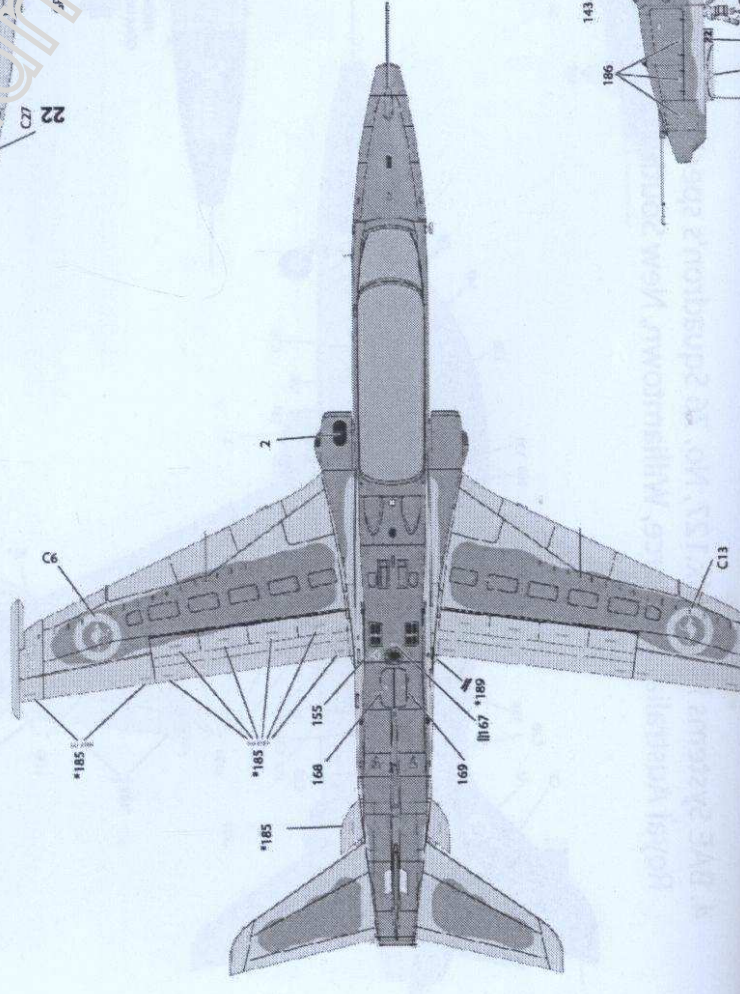
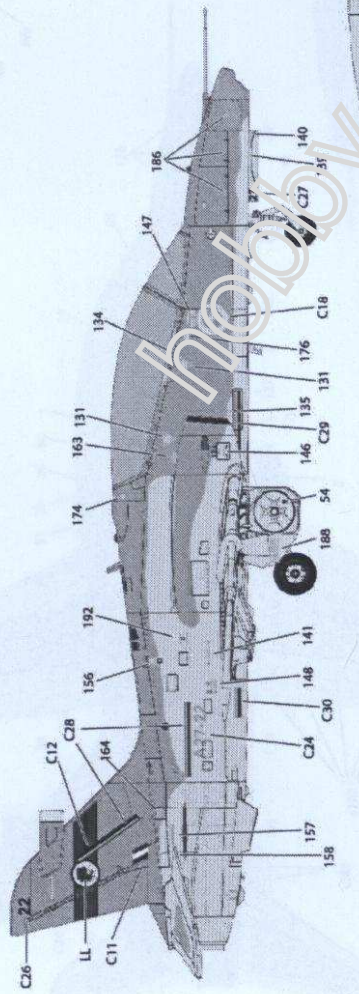
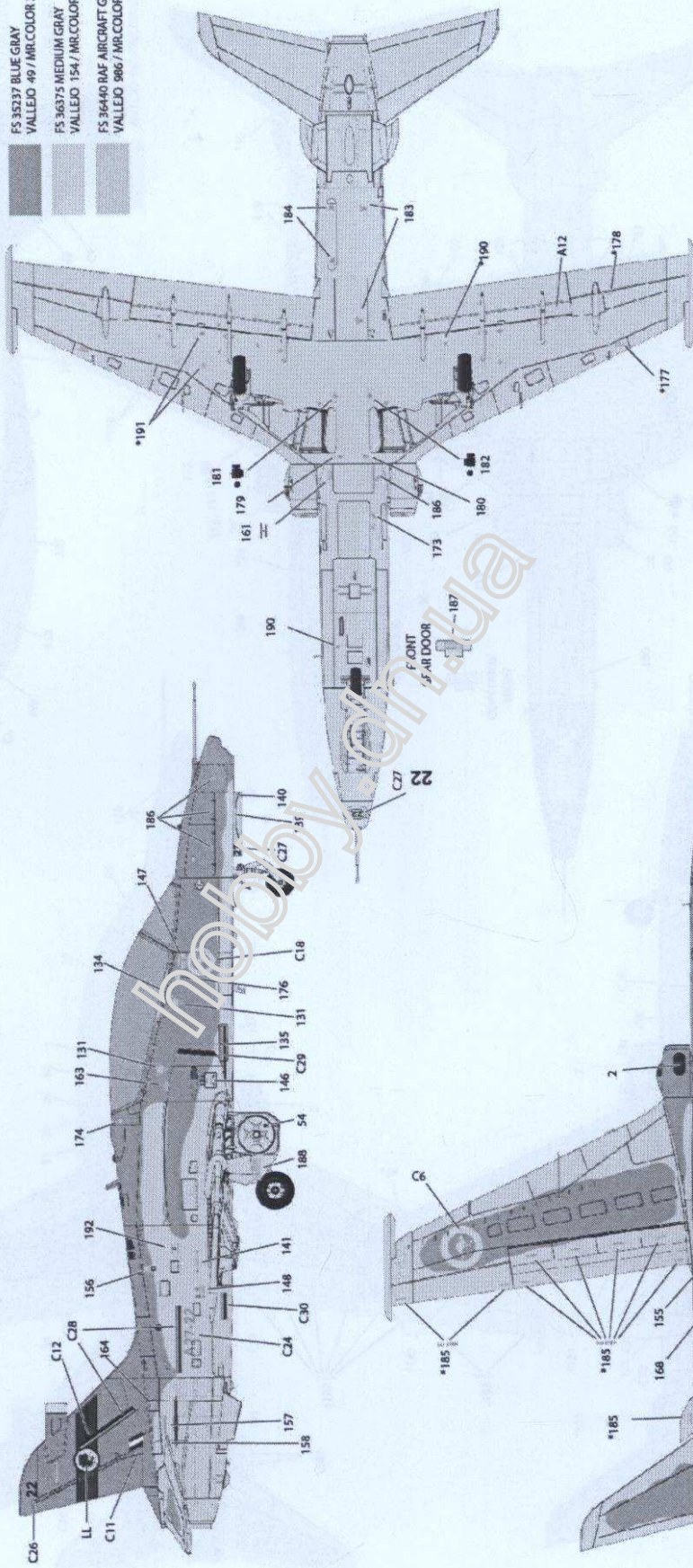

AIM-9M MISSILE

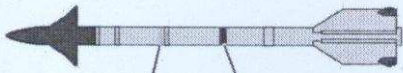

C33 C34



METALLIC GRAY
VALLEJO 863 / MR. COLOR 78



FS 36375 MEDIUM GRAY
VALLEJO 989 / MR. COLOR 308

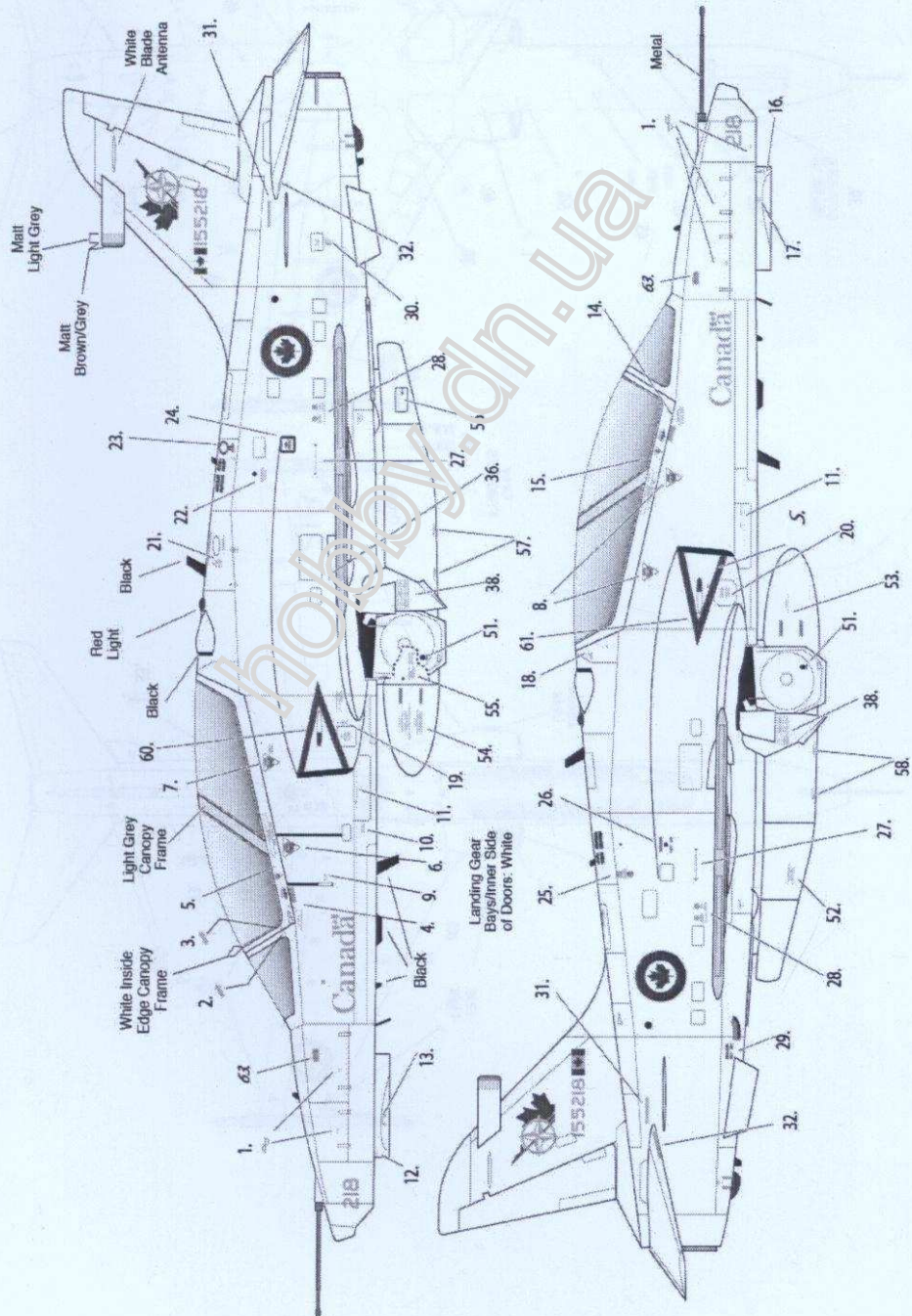

5. BAe Systems Hawk Mk.127. No. 76 Squadron, Royal Australian Air Force, Winton, New South Wales, 2011.

Aircraft overall
Gloss Insignia Blue
FS #15044

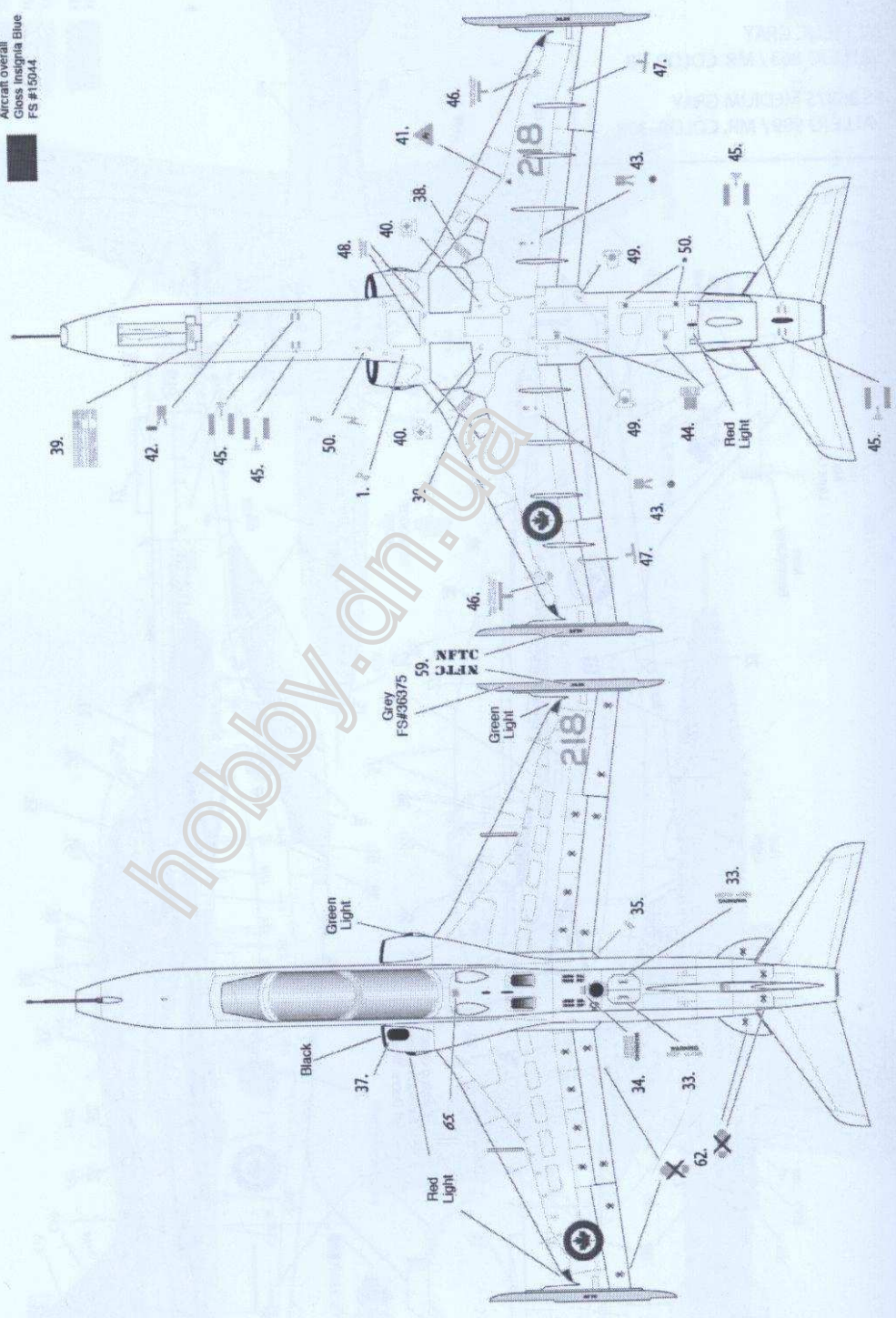

hobby.dn.us