

# Mil Mi-4 'Hound'

1:72 1:72 1:72



ART BY ADAM MARCINIAK

F-04

www.mistercraft.eu

**Short history of the Mi-4.** The Mil Mi-4, NATO name "Hound" was a Soviet transport helicopter that served in both military and civilian roles. The Mi-4 was designed in response to the American H-19 Chickasaw and the deployment of U.S. helicopters during the Korean War. While the Mi-4 superficially resembles the H-19 Chickasaw, it is a larger helicopter and is able to lift more weight. The first model entered service in 1952, and replaced the Mi-1. The helicopter was first displayed to the outside world in 1952 at the Soviet Aviation Day in Tushino. The Mi-4 transport helicopter laid the beginning of the Soviet Army Aviation, it was widely used both in the armed forces and in the national economy and for several decades remained the main type of helicopter in the inventory of the Soviet Armed Forces and of the Civil Air Fleet. The Mi-4 was replaced of the Mi-8. Mi-4 was used by more than 40 countries. Basic production version: Mi-4A: Assault transport helicopter. Mi-4AV: Armed versions based on the Mi-4A. Mi-4GF: Factory designation for demilitarized Mi-4 for use in the Civil Air Fleet. Mi-4L: Lyukes Six-seat VIP transport version, sometimes converted into an air ambulance helicopter. Mi-4VL: Fire-fighting version of Mi-4L. Mi-4M (NATO - Horned Owl): Armed close-support helicopter, fitted with a gun turret. Designation alternatively applied to the Mi-4V. Mi-4P / Mi-4VP: Civil transport helicopter, with accommodation for between 8 and 11 passengers, plus eight stretchers and a medical attendant for air ambulance duties. Upgraded version of Mi-4VM. Mi-4P / Mi-4VP: Civil transport helicopter, with accommodation for between 8 and 11 passengers, plus eight stretchers and a medical attendant for air ambulance duties. Mi-4T: Major military production version, equipped with a large diameter main rotor and bulged windows. Mi-4FV (Mi-4KV): Photographic and guidance helicopter. Mi-4Schch "Polar version" of Mi-4FV for working at the Soviet Arctic and Antarctic research stations. Mi-4SP: Special rescue modification. Mi-4PG: Experimental version equipped with an external load sling system. Mi-4SV: Mi-4 with improved heat insulation for working in the Far North. Mi-4N "Filin" (Horned owl): Experimental reconnaissance version intended for night-time use. Mi-4KK (Mi-4VKP) Mobile command post. Mi-4KU (Mi-4VPU): Mobile command post for controlling Air Force units. Mi-4U Target-designator version carrying the Oospekh (Success) system. Mi-4GR: Mi-4 fitted with Grebeshok-3 (Haircomb-3) wide-range panoramic detection and relay radar. Mi-4ARK: Mi-4 equipped artillery reconnaissance and spotting helicopter. Mi-4MK (Mi-4PP): ECM version. Mi-4UM: Radio-controlled target drone version. Harbin Z-5 Chinese military transport helicopter. **Basic tactic and technical data:** • Crew: One or two pilots • Capacity: 16 troops or up to 1,600 kg (3,520 lb) of cargo • Length: 16.80 m (55 ft 1.4 in) • Rotor diameter: 21.00 m (68 ft 11 in) • Height: 4.40 m (14 ft 5 in) • Disc area: 346.4 m<sup>2</sup> (3,727 ft<sup>2</sup>) • Empty weight: 5,100kg (11,220 lb) • Loaded weight: 7,150 kg (15,730 lb) • Max. takeoff weight: 7,550 kg (16,640 lb) • Powerplant: 1 x Shvetsov ASh-82V radial engine, 1,250 kW (1,675 hp) • Performance: • Maximum speed: 185 km/h (116 mph) • Range: 500 km (313 mi) • Service ceiling: 5,500 m (18,040 ft) • Rate of climb: m/s (ft/min) • Disc loading: 41 kg/m<sup>2</sup> (8 lb/ft<sup>2</sup>) • Power/mass: 0.21 kW

●GB. Marking and Painting Guide ●D. Markierung und Bemalanleitung ●PL. Oznaczenie i Malowanie ●F. Peinture et marquage Guide ●NL. Schilderen en markeringen gids

## 1 Mil Mi-4T LLP (Ludowe Lotnictwo Polskie) Polish Air Force Warszawa, Babice A.B. 1960s

Colours

FS-35189  
FS-33333  
FS-33434  
FS-35526

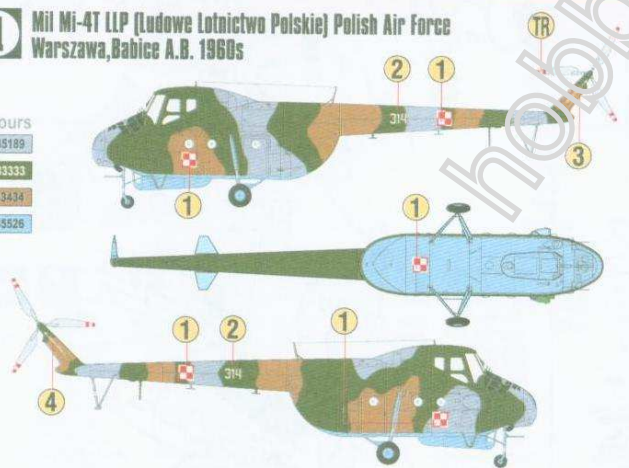

## 2 Mil Mi-4T Военно Воздушные Силы, ВВС Москва, СССР 1960 Soviet Air Force, Moscow, 1960s

Colours

FS-34102  
FS-35526



## 3 Mil Mi-4T Военно Воздушные Силы, Жытомір Украина, УССР 1960 Zytomir, Ukrainian Soviet Rep. 1960

## 5 Mil Mi-4T Военно Воздушные Силы, ВВС Полярная Зона, 1960s Polar Zone, North Russia 1960s

Colours

FS-18913

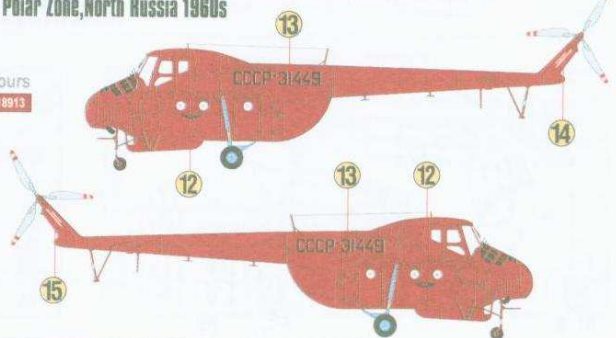

## 4 Mil Mi-4T LLP (Ludowe Lotnictwo Polskie) Warszawa, Babice A.B. 1960s

Colours

FS-36270  
FS-34095  
FS-33440  
FS-35526





# GB.Assembly instruction

- D.Montageanleitung
- PL.Instrukcja montażu
- F.Notice de montages
- Cz.Montážní návod
- Инструкция по монтажу



Glue  
Kleben  
Przykleić  
Coller  
Lijmen  
Engomar  
Colar  
Incollare  
Limmas  
Limmaa  
Limes  
Lim  
Клеить  
κόλλημα  
Yapıştırma  
Lepeni  
ragasztani  
Lepiti  
Lipici  
лепило  
клеи



Don't glue  
Nicht kleben  
Nie przyklejać  
Ne pas coller  
Niet lijmen  
No engomar  
Nào colar  
Non incollare  
Limmas ej  
Älä limmaa  
Skal IKKE limes  
Ikke lim  
He kleeft  
μη κόλλάτε  
Yapıştırmayın  
Nelepit  
Nem szabad ragasztani  
Ne lepiri  
Nu lipici  
He лепило  
He клеи

**1**  
STEP

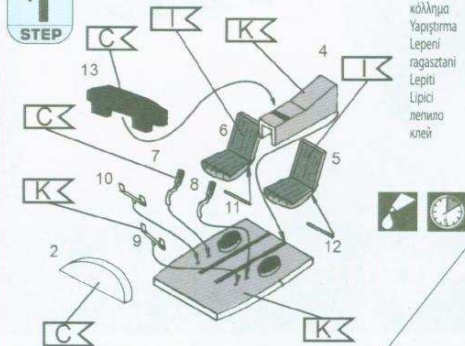

**2**  
STEP

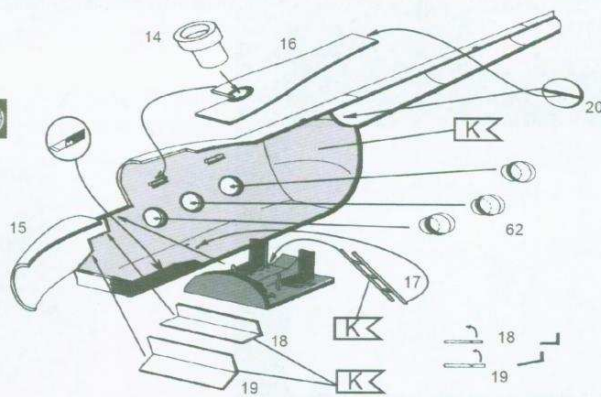

**3**  
STEP

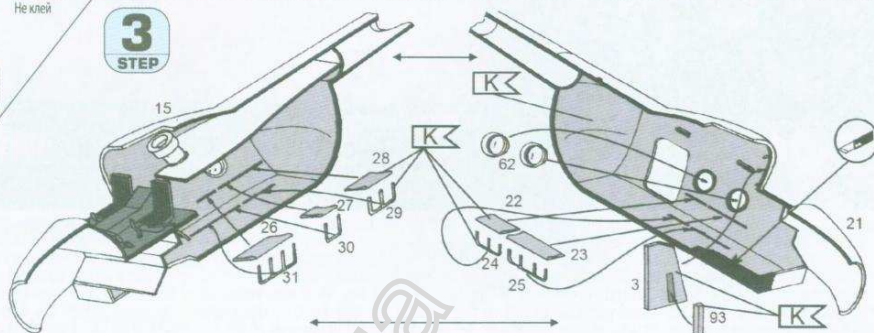

**4**  
STEP

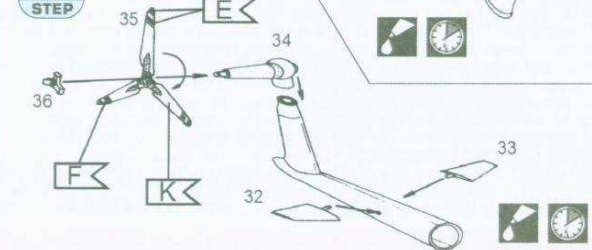

**5**  
STEP

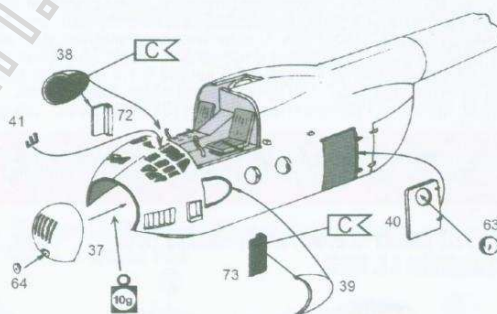

**6**  
STEP

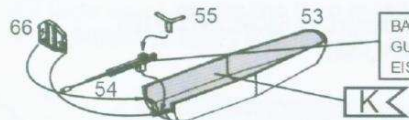

BARVA ZB  
GUNMETA  
EISEN

**7**  
STEP

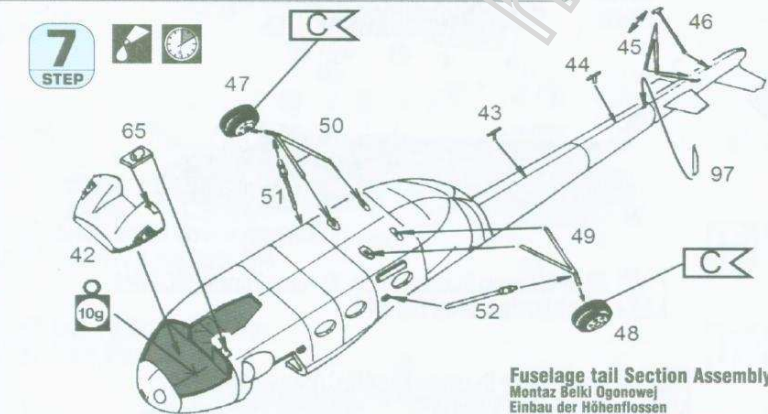

Fuselage tail Section Assembly  
Montaż Belki Ogonowej  
Einbau der Höhenflossen  
Fixation des stabilisateurs horizontaux

**8**  
STEP

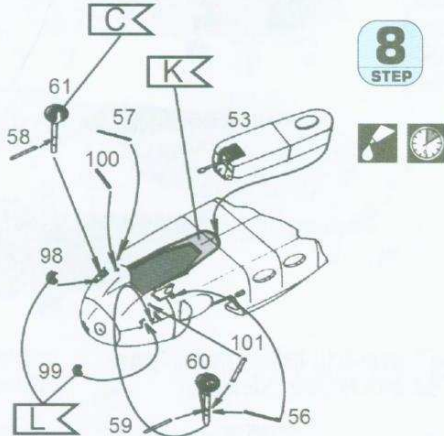

**9**  
STEP

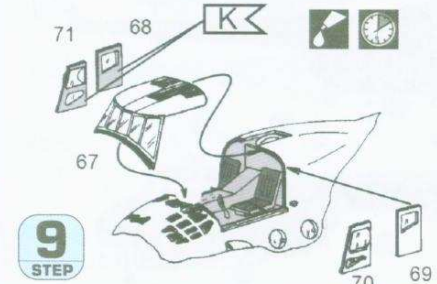

**10**  
STEP

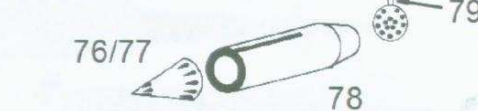



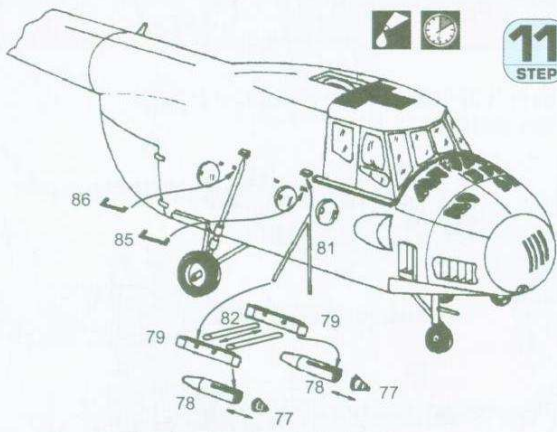

**11**  
STEP

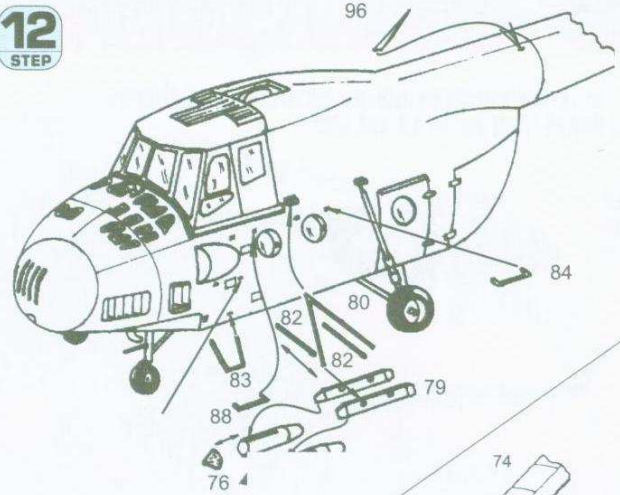

**12**  
STEP



Adhesive tape  
Klebeband  
Tašma klejaca  
Dévidoir de ruban adhésif  
Plakband  
Cinta adhesiva  
Fita adesiva  
Nastro adesivo  
Tejp  
Teippi  
Tape  
Tape  
Клейкая лента  
κόλλητική ταινία  
Yapıştırma bandı  
Lepící páska  
ragasztószalag  
Traka z lepilom  
Banda adesiva  
Лепеники  
Скотч

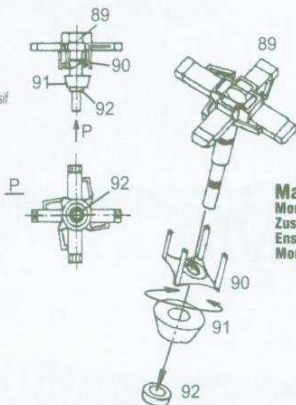

**13**  
STEP

**Main Rotor Assembly**  
Montaż Wirnika Głównego  
Zusammensetzung der Hauptrotor  
Ensemble du Rotor Principal  
Montaje de Rotor



Paint  
Bemalen  
Pomalować  
Peindre  
Beschilderen  
Pintar  
Dipingere  
Pintar  
Måla  
Male  
Mal  
Malare  
Pomalovat  
Beschildern  
Покрасить  
Pomalovat  
Arayamak  
Pomalovati  
Vopsea  
Червя  
Малювати



**15**  
STEP

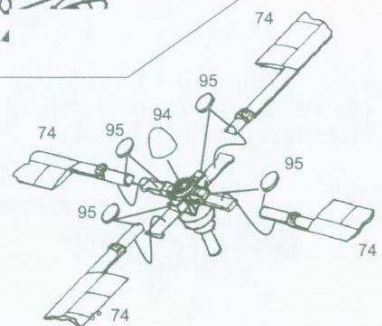

**14**  
STEP

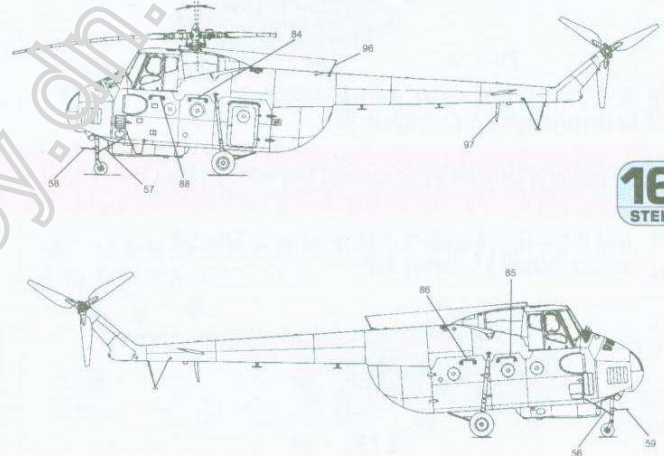

**16**  
STEP

<b>A</b> FS 34102 RAL 6003	<b>B</b> FS 27925 RAL 9016	<b>C</b> FS 17038 RAL 9016	<b>D</b> FS 34108 RAL 9016	<b>E</b> FS 32199 RAL 3002	<b>F</b> FS 17875 RAL 9016	<b>G</b> FS 36081 RAL 9011	<b>G</b> FS 36173 RAL 9011	<b>J</b> FS 13655 RAL 1028	<b>K</b> FS 35237 RAL 7004
Dark green, matt dunkelgrün, matt Ciemnozielony, matowy vert foncé, mat donkergrön, mat verde oscuro, mate verde escuro, fosco verde scuro, opaco mörkgrön, matt tummanvihreä, himmeä mörkgrön, matt markgrün, matt темно-зеленый, матовый Prádko okázlo, jutt Koyu yeşil, mat tmaozelená, matná sötétzöld, matt temnozelena, mat verde închis, mate тёмно-зелено, матов темно-зеленый, матовый	Light blue, matt lichtblau, matt Jasnoniebieski, matowy lichtblau, mat azul celeste, mate azul celeste, fosco blu celeste, opaco juszblá, matt vaaleansininen, himmeä lysende blå, mat lysblå, matt светло-голубой, матовый juttke puhtos, jutt gök mavisi, mat svärlmodrå, matná világító kék, matt svetlo plava, mat pal albastru, mat лед син, матов блiдкий блакитний, матовый	Black, matt schwarz, matt Czarny, matowy noir, mat zwart, mat preto, fosco nero, opaco svart, matt musta, himmeä sort, mat sort, matt черный, матовый juttro, jutt siyah, mat černá, matná fekete, matt črna, mat negru, mate черен, матов чорний, матовый	Medium green, matt Mittelgrün, matt Sredniozielony, matowy Vert moyen, mat Middelgrön, mat Verde medio, mate Verde medio, fosco Verde medio, opaco Mellangrön, smatt Keskivihreä, himmeä Mellegrön, mat Mellegrön, matt Средний-зеленый, мат. Prádko usozlo, jutt Orta yeşil, mat Közepzöld, smatt Srednjesiva zelena, mat mediu verde, mate средно-зелено, матов середній-зелений, матова	Karminrot, matt 36 carmin red, matt Karminowy, matowy rouge carmin, mat karminrood, mat carmin, mate vermelho carmin, fosco rosso carminio, opaco karminröd, matt karmininpunainen, himmeä karminröd, mat karminröd, matt красный кармин, матовый кочколю оаінжо, jutt lál renji, mat krbové červená, matná šarmínrosu, matt kármin rdeča, mate carmin roșu, mate кэрмін чэрвона, матов кармін-чырвонаго, матовый	White, matt weiß, matt Biały, matowy blanc, mat wit, mat blanco, mate branco, fosco bianco, opaco vit, matt valkoinen, himmeä hvid, mat hvit, matt белый, матовый Ляко, jutt beyaz, mat biła, matná fehér, matt befa, mat alb, mat бял, матов білий, матовый	Dunkelgrau, seidenmatt Dark grey, silky-matt Ciemnoszary, jedwabisto-matowy gris foncé, satiné mat Donkergris, zijdemat gris oscuro, mate seda cinzento escuro, fosco sedoso grigio scuro, opaco seta Mörkgrå, sidennatt Tummanharmaa, silkinhimeä Mörkegrå, silkematt Ciemnoszary, jedwabisto-matowy уқро оқидро, шёлковисто-матовый Koyu gri, ipek mat Tmevošedá, hedvábné matná Sötétzürke, seylemmatt Temnosiva, svila mat gri închis, matasoasa-mate тёмно-серый, шёлковисто-матов темно-сірий, шёлковисто-матова	Yellow, matt gelb, matt Złoty, matowy jaune, mat geel, mat amarillo, mate amarelo, fosco giallo, opaco gul, matt keltainen, himmeä gul, matt gul, matt желтый, матовый кiтрово, jutt sarı, mat žluta, matná sárga, matt rumena, mat galben, mate жылт, матов жовтий, матовый	Medium grey, matt mittelgrau, matt Srednioszary, matowy gris moyen, mat middelgris, mat gris medio, mate cinzento-medio, fosco grigio medio, opaco mellangrå, matt keskivihreä, himmeä mellomgrå, matt mellomgrå, matt средний-серый, матовый гкго меозло, jutt orta gri, ipek mat střed šedá, matná közepszürke, matt srednjesiva siva, mat mediu gri, mate средно-сив, матов середній-сірий, матова	

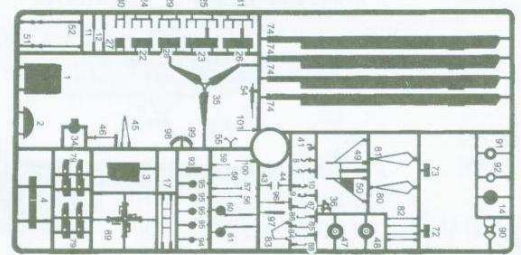
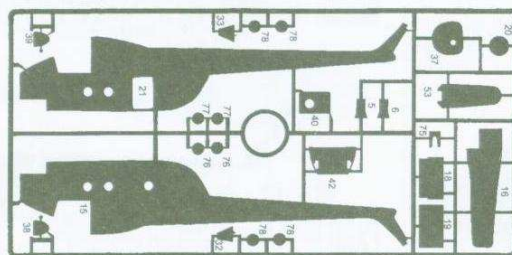
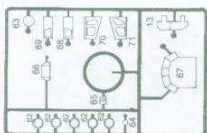



# Marking & Painting

•DEN. Bemaling og markeringer Guide •NOR. Maleri og Markings Guide •RUS. Окраска и маркировка руководство •GR. Ζυρωφική και Σημάσεις Οδηγός •CZ. Malování a Značení

## 6 Mi-4A Luftstreitkräfte der Nationalen Volksarmee - LSK HG-31/HG-34 (DDR Air Force), Cottbus A.B., DDR, 1963

Colours

- FS-33333
- FS-33494
- FS-33333

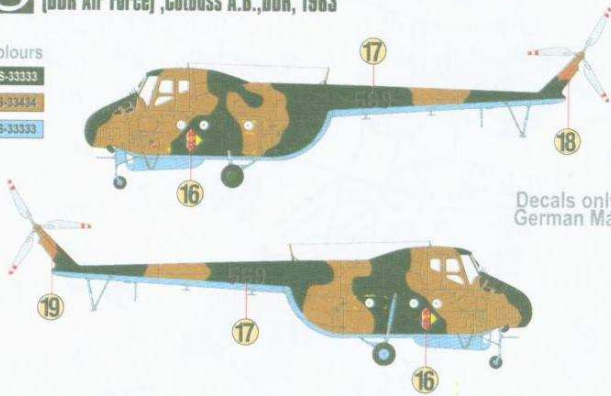

Decals only for German Market

## 7 Mi-4A Luftstreitkräfte der Nationalen Volksarmee - LSK HG-31 (DDR Air Force), Hanover A.B., DDR, 1962

Colours

- FS-33333
- FS-35526



Decals only for ex-Czechoslovakian Market

## 10 Mi-4A Československé Vojenské Letectvo (Czechoslovakian Air Force) Prostějov A.B. Czechoslovakia 1962

Colours

- FS-34102
- FS-35526

## 8 Mi-4A LLP (Ludowe Lotnictwo Polskie) Polish Air Force Warszawa, Leczyca A.B. 1960s

Colours

- FS-30117
- FS-30117
- FS-35526

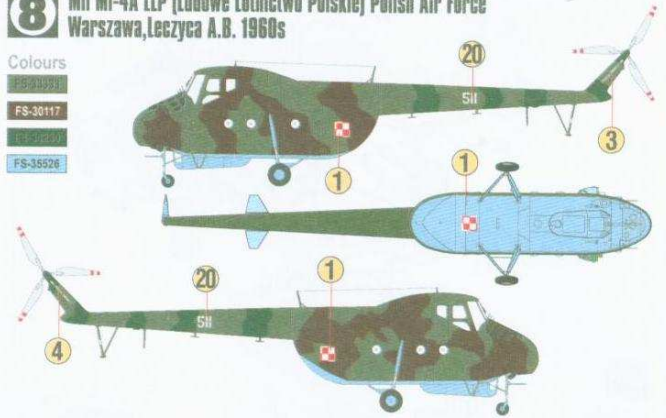

## 9 Mi-4A Československé Vojenské Letectvo (Czechoslovakian Air Force) Přerov A.B. Czechoslovakia 1962

Colours

- FS-34102
- FS-37031



Decals only for ex-Czechoslovakian Market

•TUR. Kılavuz Boyama ve Markalama •H. Festék rendszer és jelölések •SK. Malovanie a značenie Guide •Rum. Marcarea si pictura Ghid

•SUL. Живопис и маркировка Ръководство •UA. Маркування та живопис керівництво

## 11 Mi-4A Magyar Légierő Hungarian Rebel Forces during Hungarian Uprising, Budapest A.B., Hungary 1956

Decals only for Hungarian Market

Colours

- FS-34102
- FS-35526



Decals only for South-East Asia Market

Colours

- FS-18913



## 12 Mi-4A (Angkatan Barat) Indonesian Army Djakarta A.B., Indonesia 1974

## 13 Mi-4A Forțele Aeriene Române (Romanian Defence Forces), Bucuresti A.B., Romania 1968

Decals only for Romanian Market

Colours

- FS-34102
- FS-35526



Decals only for Scandinavian Market

## 14 Mi-4A Ilmavoimat Finnish Air Force, Helsinki A.B., Finland 1970

## 17 Mi-4A Yugoslavian Air Force, Belgrad A.B., Yugoslavia 1970

Decals only for ex-Yugoslavian Market

Colours

- FS-34102
- FS-35526

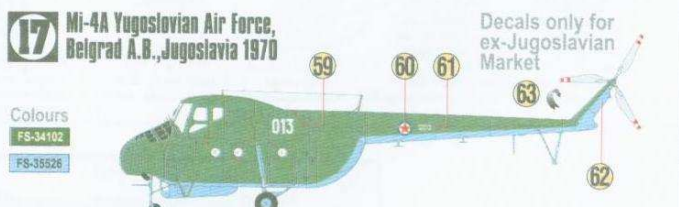

Decals only for Bulgarian Market

## 18 Mi-4A Военновъздушни сили, ВВС, Plovdiv A.B., Bulgaria, 1970

Colours

- FS-34102
- FS-35526



## 15 Habin Z-5, China People's Army Benjin, China 1965

Colours

- FS-34102
- FS-35526



Decals only for South-East Asia Market

## 16 Mi-4A Không quân Nhân dân Việt Nam, Ha Noi A.B., Vietnam, 1970

Colours

- FS-34102
- FS-35526

