

modelcollect

USA M983A2 HEMTT TRACTOR AND SOVIET MAZ 7410 TRACTOR COMBO

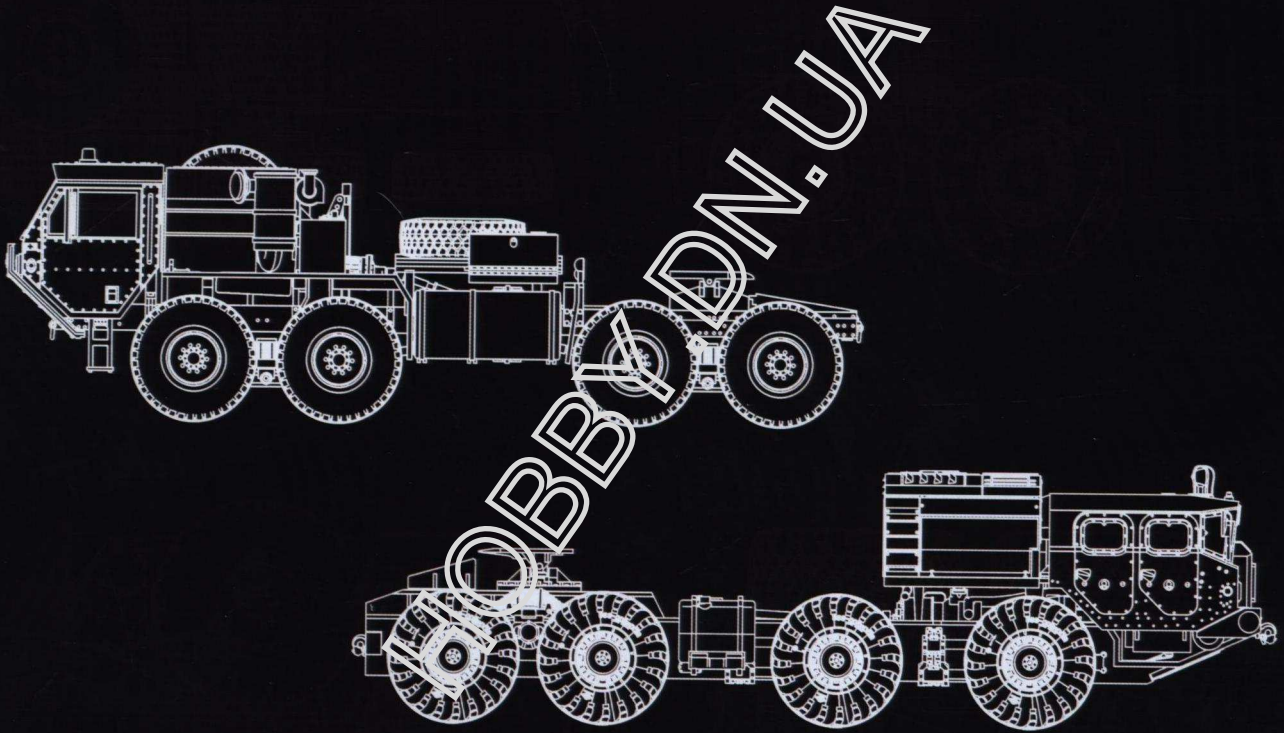

雙模閣

MA72009

2IN1  
LIMITED  
EDITION

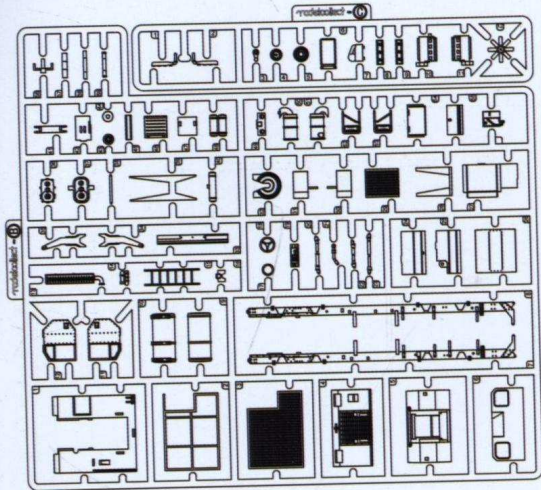

Ax2

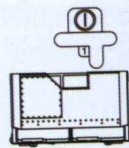
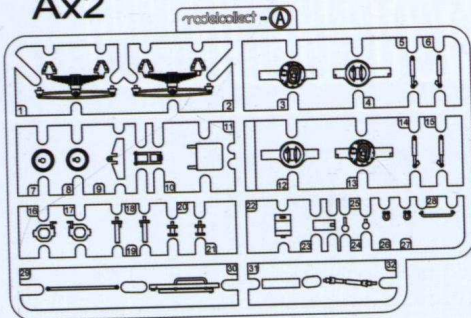

Fx2

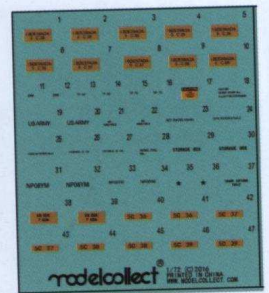
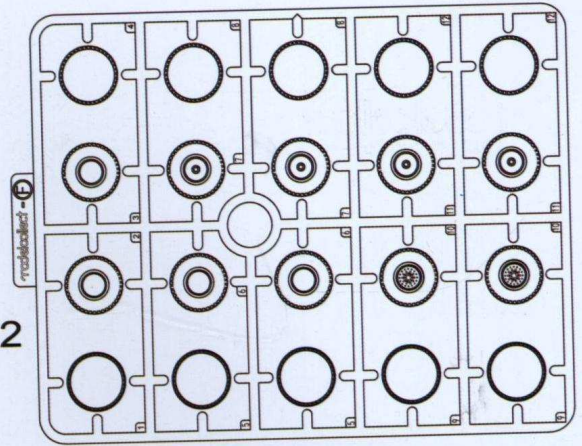

Decal

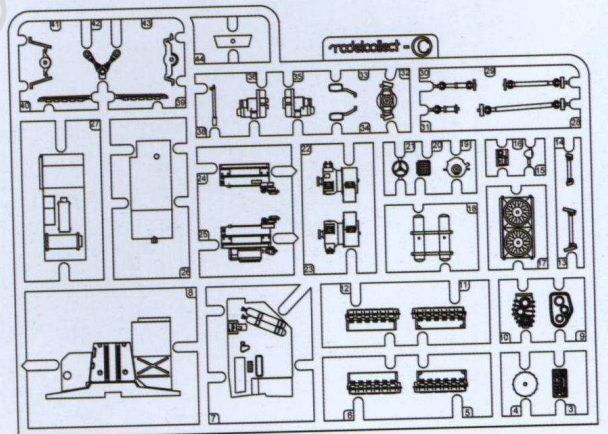
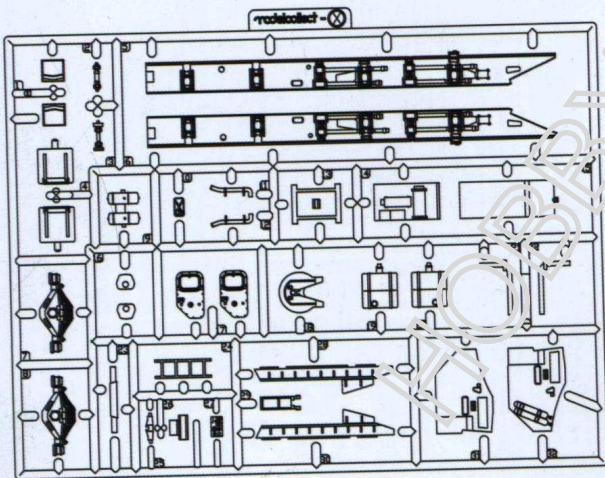

Dx2

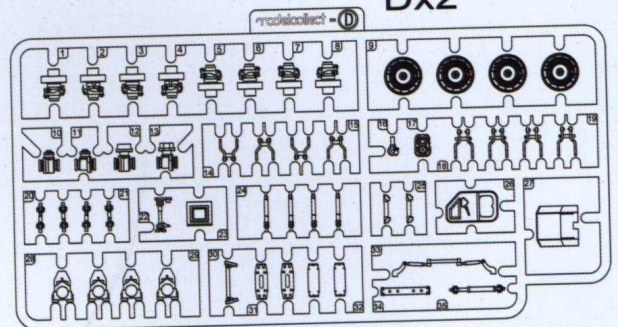
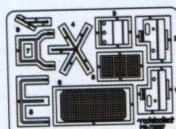
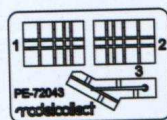
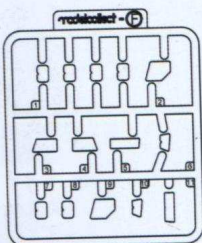

Decal

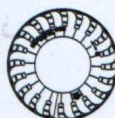
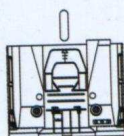

x 8

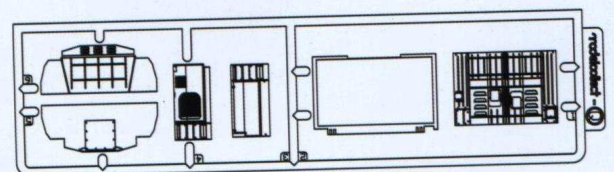

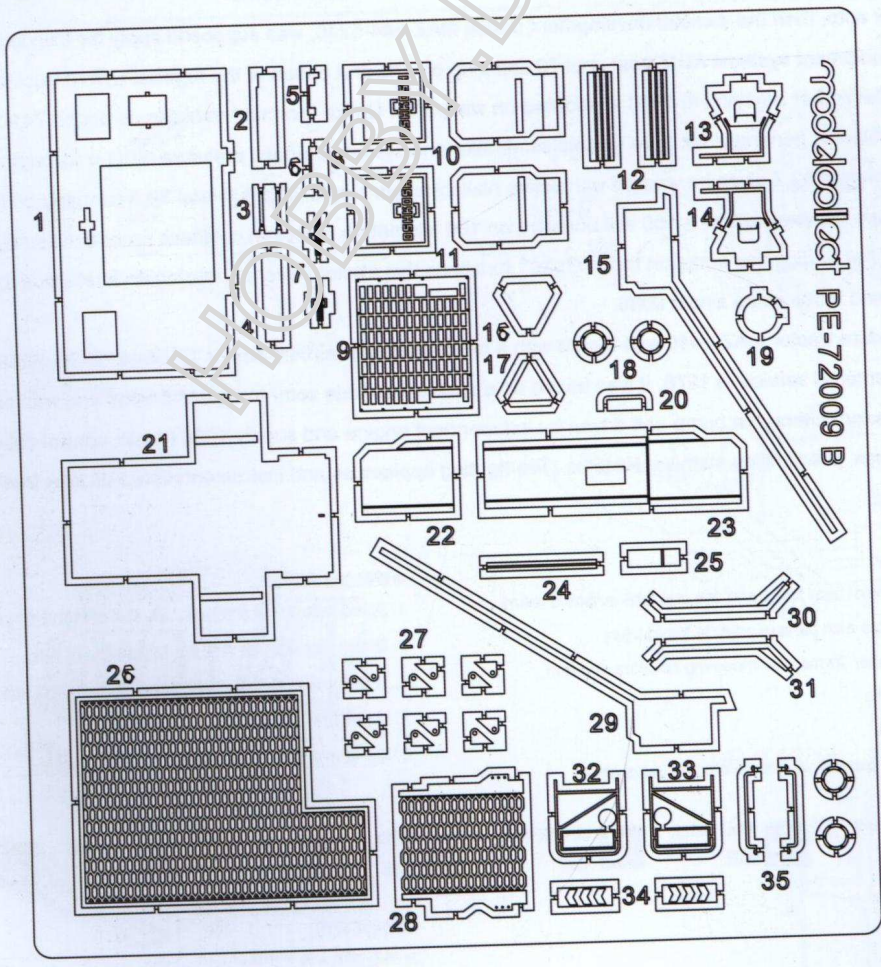
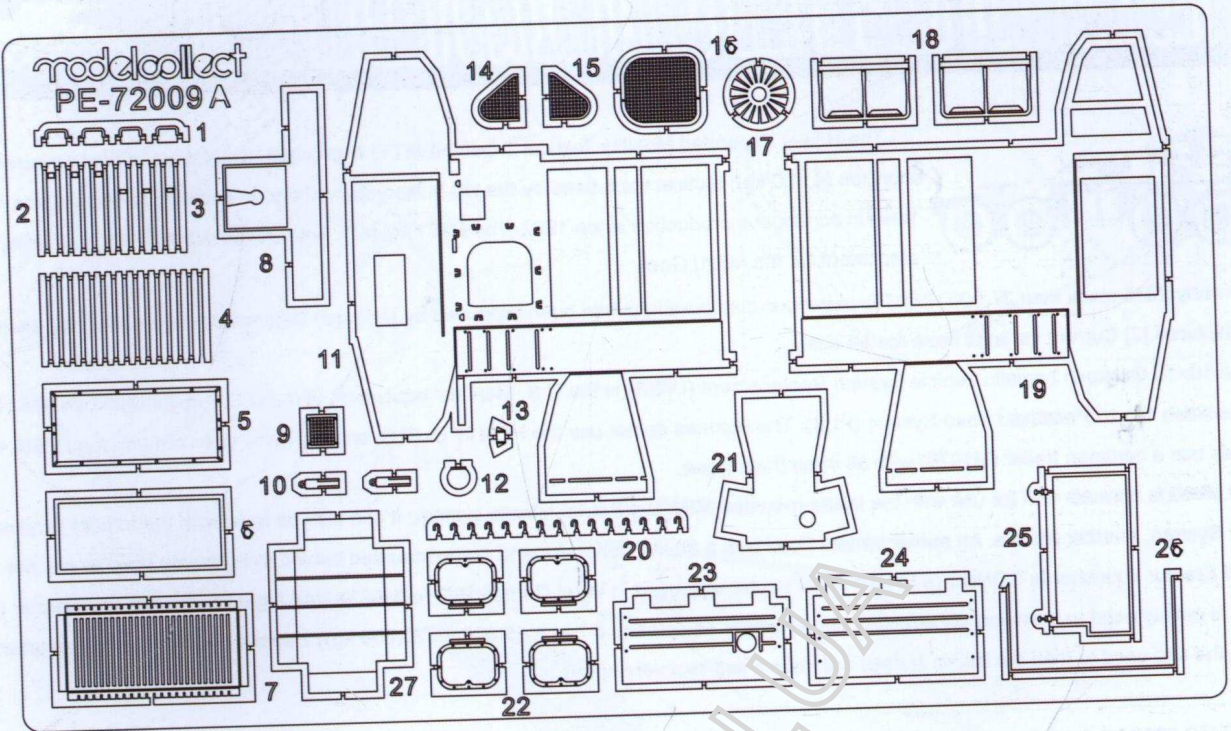

# USA M983A2 HEMTT TRACTOR AND SOVIET MAZ 7410 TRACTOR COMBO

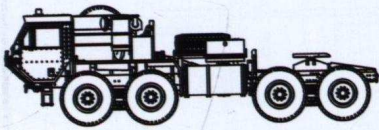

The Heavy Expanded Mobility Tactical Truck (HEMTT) is an eight-wheel drive, diesel-powered, 10-short ton (9,100 kg), tactical truck used by the US military and others. In evolving configurations it has been in continuous production since 1982. The M977 HEMTT entered service with the U.S. Army as a replacement for the M520 Goer.

By early 2015 more than 27,000 HEMTTs in various configurations had been produced by Oshkosh Defense through either new-build or re-manufactured.[2] Current variants have the A4 suffix.

The 10x10 Oshkosh Logistic Vehicle System Replacement (LVSR) is the U.S. Marines' equivalent of the U.S. Army's Oshkosh 8x8 HEMTT and Oshkosh 10x10 Palletized Load System (PLS). The Marines do not use the HEMTT or PLS, and the Army does not use the LVSR, but both services use a common trailer (M1076) with all three truck types.

The M983 is a tractor unit for use with the trailer-mounted MIM-104 Patriot missile system. It can also be used with the Interim Stryker Recovery System, or other trailers. An earlier variant fitted with a 30 kW generator and crane mounted behind the cab was used to tow the Pershing II Erector Launcher in CONUS (a M1001 MAN tractor was used in West Germany). The M983A2/A4 Light Equipment Transporter (LET) tractor is mainly used to transport construction and engineer equipment. It has a 45,000 lb (20,000 kg) 2 speed hydraulic winch mounted behind the cab used to load the trailer. It does not have a self-recovery winch.

MAZ-7410-9988 "Oplot-B" – experienced active auto in the composition of the 670-strong vehicles up of the tugboat MAZ-7410 and dvukhosnogo 30-ton nizkoramnogo semitrailer MAZ-9988 with gidrostaticheskoy system drive four odnoskatnykh leading wheels and Erection altitude frame

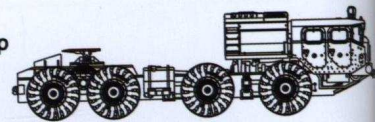

1,200 – 1,300 mm. A new auto, then the seminal development option MAZ-544-5246, was supposed apply for towing dire active semi-trailers with krupnogabaritnym equipment systems ADIZ host until 70 camping on The first option of the tugboat E7410 truck E9988 emerged in 1974, ispytyvalsya in October-December next and in 1978 st adopted on weaponry. Unlike "normal" vehicles up option 74101 truck 7410 snabzhal-sya an additional a hydroelectric generator for drive wheels semitrailer and system changes pressure air in tires from model 7911. In the composition of the lorry convoy weight 62,7 gives he worked with 20 nize nizkoramnym single 9988 full host 39.5 camping on His Toyota length basket reached 21,8 forge the fuels the expenditure – 100 km on 100 kilometers, maximal coolness preodolevaemogo rise of – 24 °, stock-pile of course – 730 km. After ending the works on topic "Oplot" functions this tractor trailers nurturing an analogous tow truck MAZ-74106 with 525-strong the engine of and those same single 9933.

The experimental procedure tractor MAZ-7410 was tested with a tank-semitrailer airfield tanker TZ-30 (APP-30 -9989) production Zhdanov heavy engineering plant, entered service in 1978. It was based on a special two-axle semi-trailer MAZ-9989 and was equipped with a steel tank with a capacity of 30 thousand. Liters, the pump unit driven by independent engine and supply 1000 l / min, control cabin on the left side of the tank, filter systems, pipelines, petrol filling sleeves, Nozzles , fire-fighting appliances and instrumentation. Full tank truck weight - 41.1 tons, the whole train - about 65 tons.

●READ BEFORE ASSEMBLY

1. When you use glue or paint, do not near flame, and use in a well-ventiated room.
2. Take extra care in handling photo etch parts in order to avoid injury
3. When you take parts off the runner frame, use modeling scissors and trim excess plastic with a cutter or a file.
4. Glue and paint are not included.
5. This product is only suitable for experienced more than 14 years old.

●装配之前仔细阅读:

1. 勿於近火处使用胶水或油漆, 并 打开窗户保持空气流通。
2. 取蚀刻片时应特别注意安全, 防止利边划伤手指。
3. 从胶架上取出部件时, 应用模型专用剪, 并用界刀或小锤除去多余的胶料。
4. 请使用塑料胶水和油漆, 模型内不含。
5. 本产品不适合14岁以下没有经验的模型爱好者。

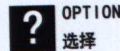
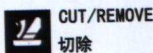
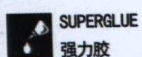

DECAL APPLICATION

1. Cut off decal from sheet.
2. Dip the decal in tepid water 40° C for about 10 sec. and place on a clean cloth.
3. Hold the backing sheet edge and slide decal onto the model.
4. Move decal into position by wetting decal with finger.
5. Press decal gently down with a soft cloth until excess water and air bubbles are gone.

水贴纸的使用:

1. 从水贴上剪下印花。
2. 将印花放入温水中浸10秒, 然后放在干净布上。
3. 拿着印花纸板将印花移到模型上。
4. 手指蘸水将印花移到适当的位置。
5. 用软布轻压印花直至不干, 气泡消失。

1

M983车头PE细节改造 1  
M983车头PE细节改造 1  
M983 driver cabin detail set update 1

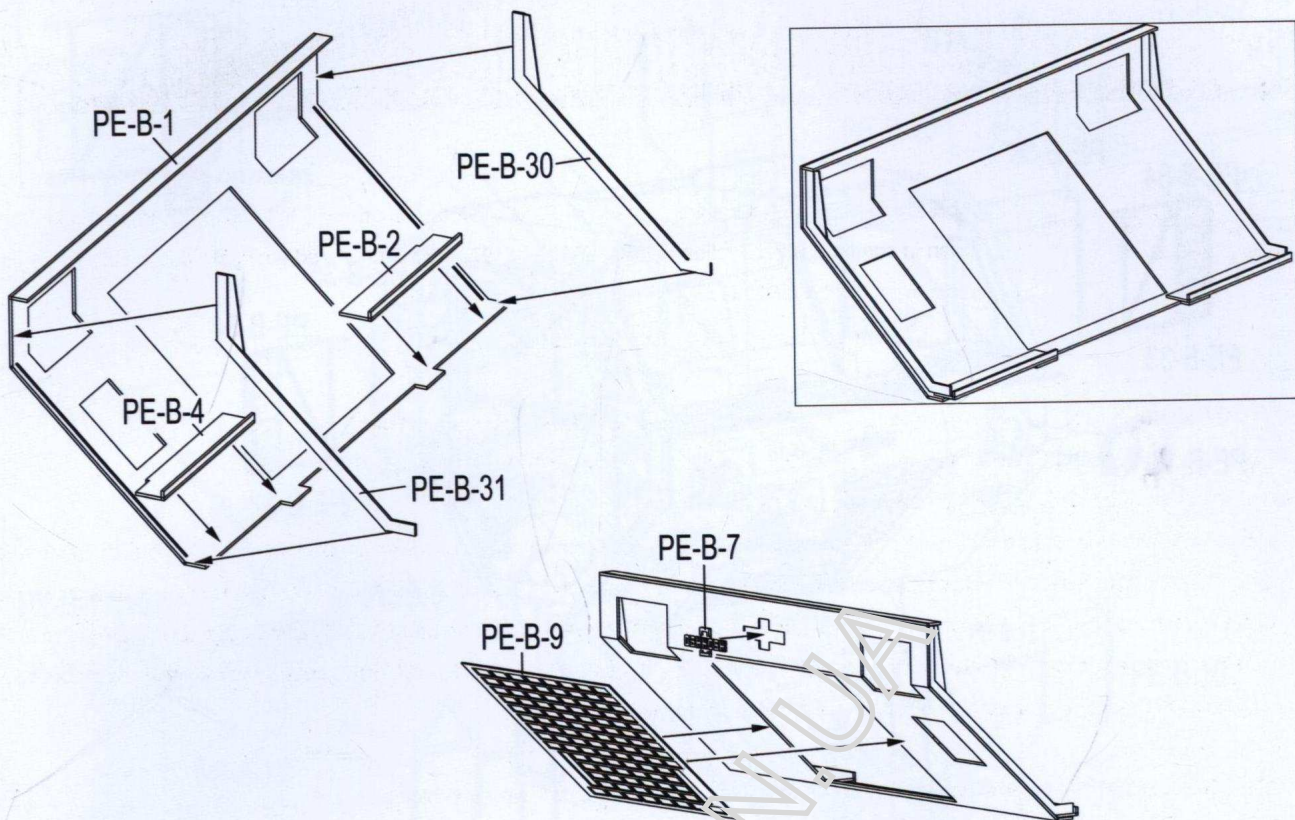

2

M983车头PE细节改造 2  
M983车头PE细节改造 2  
M983 driver cabin detail set update 2

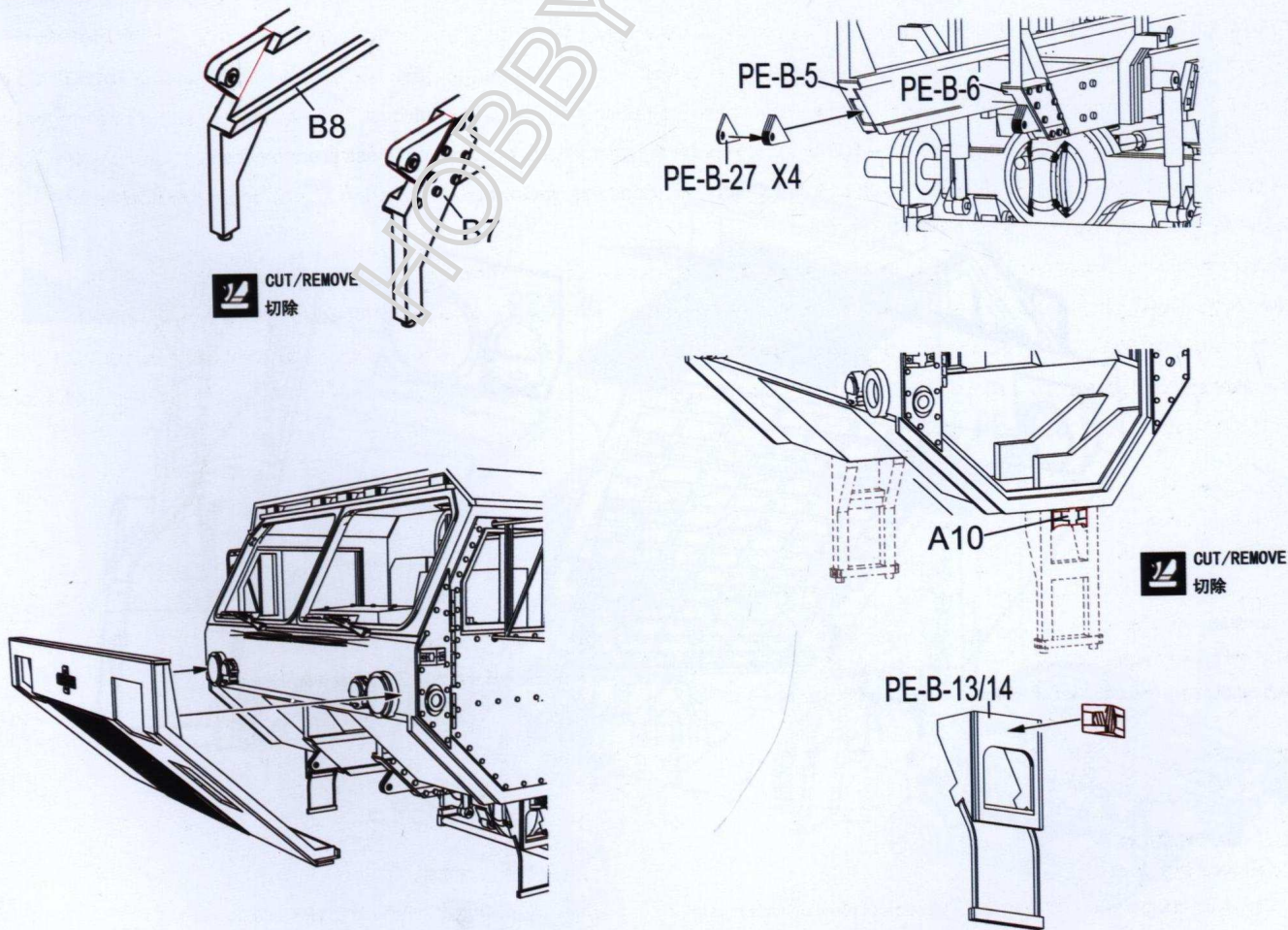

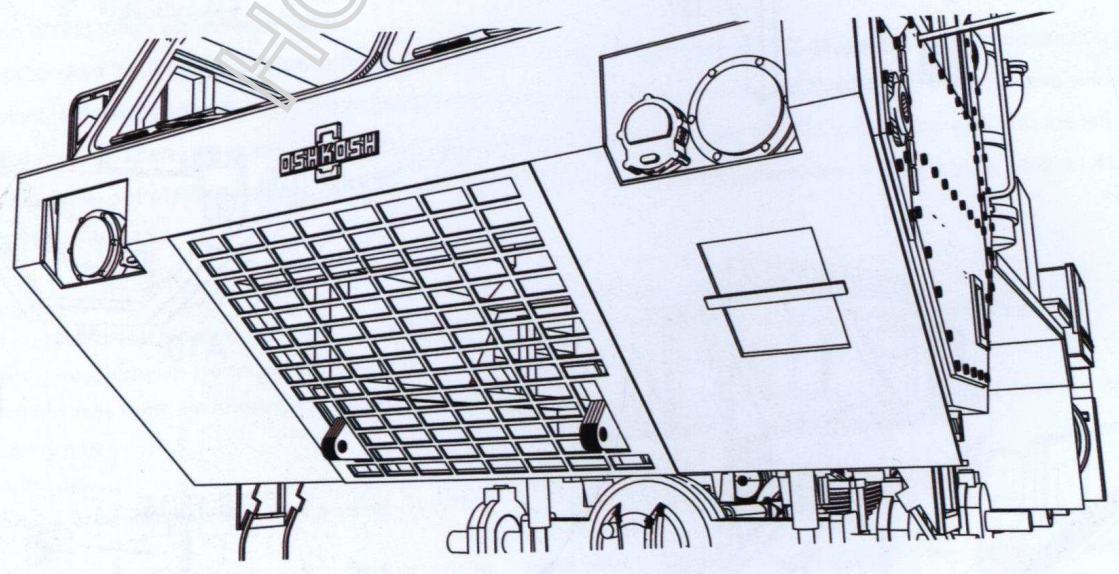
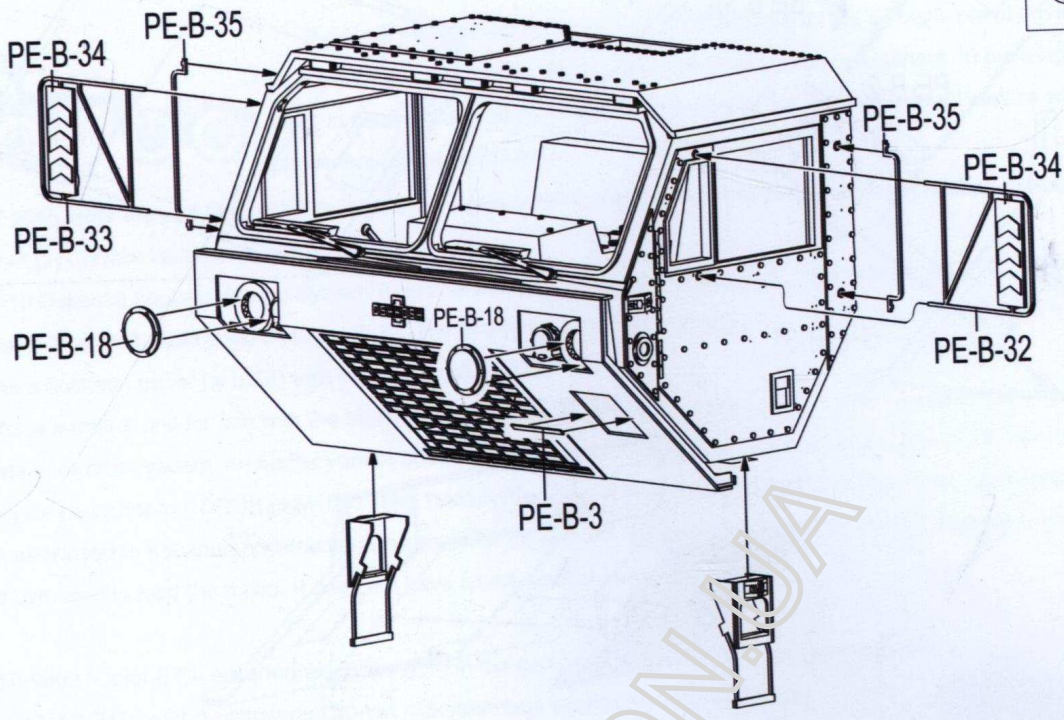

5

M983 车体细节改造 1  
M983 車體細節改造 1  
M983 body detail set update 1

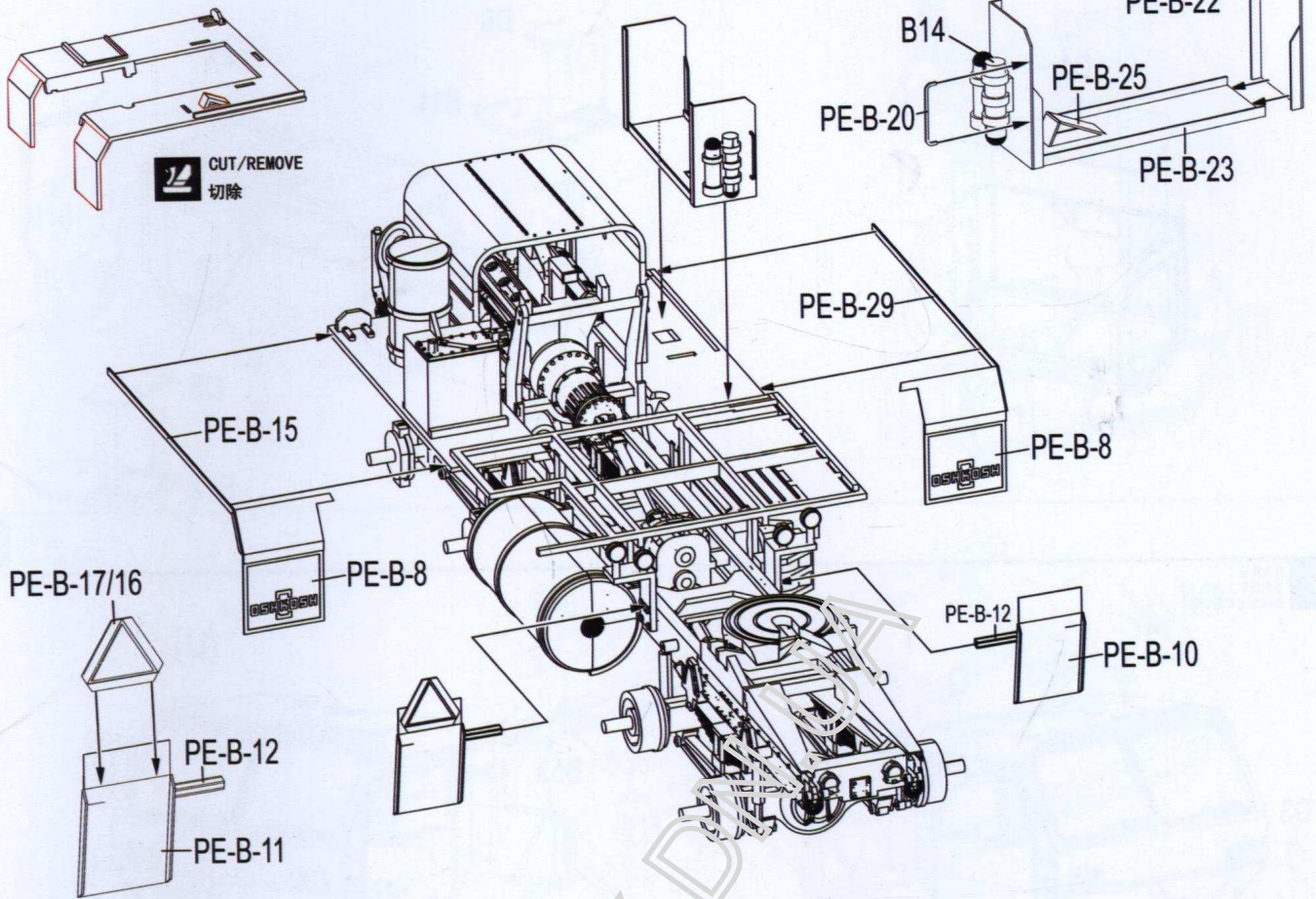

6

M983 车体细节改造 2  
M983 車體細節改造 2  
M983 body detail set update 2

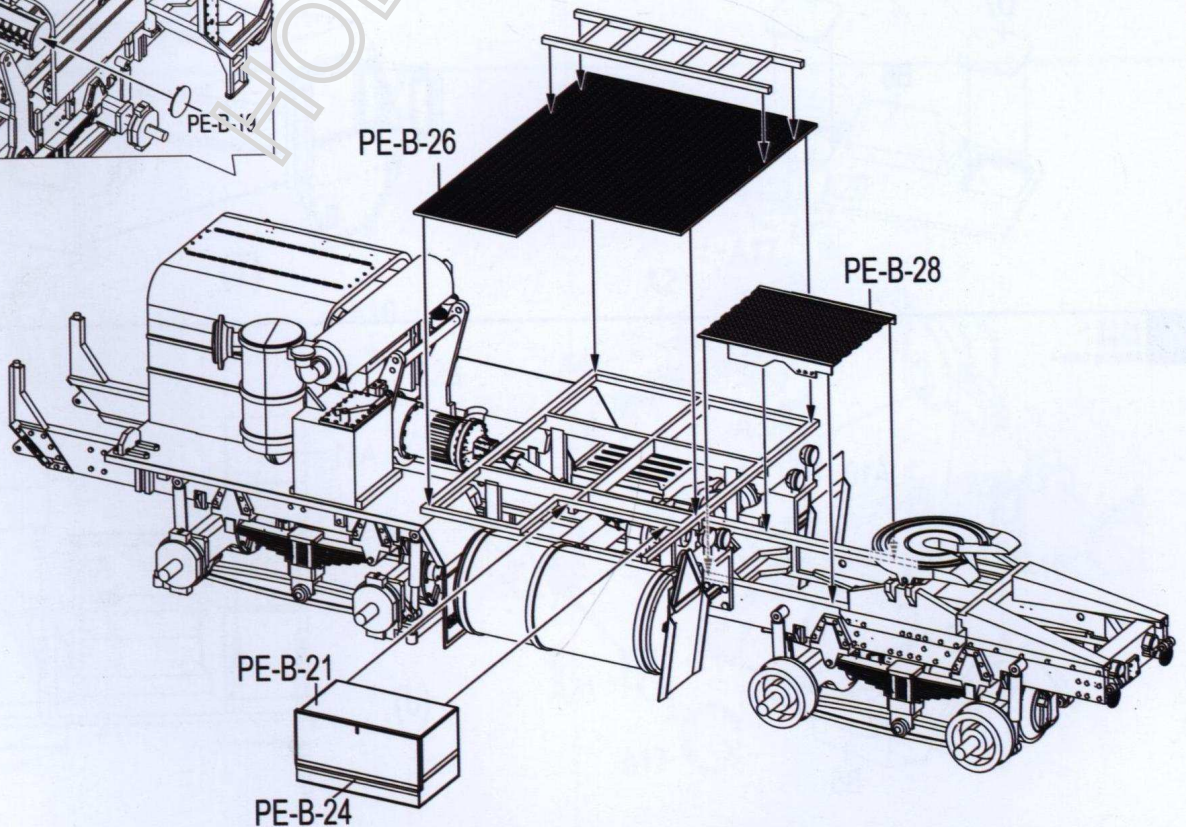
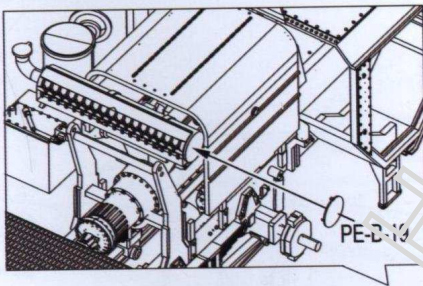

1 车头组装 1  
车头组装 1  
Attaching Cabin 1

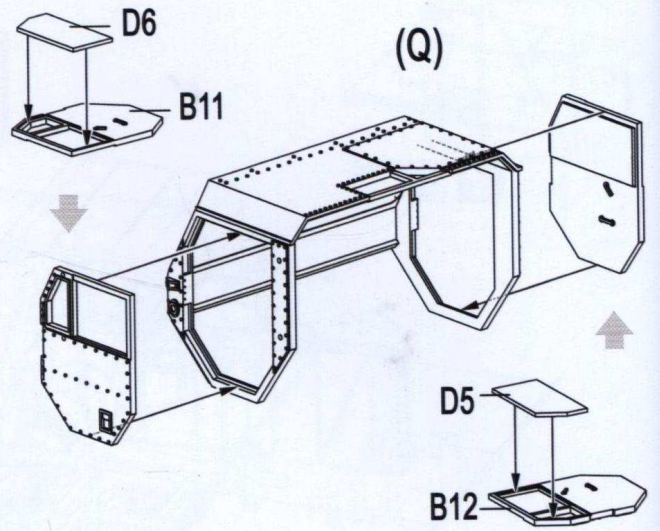
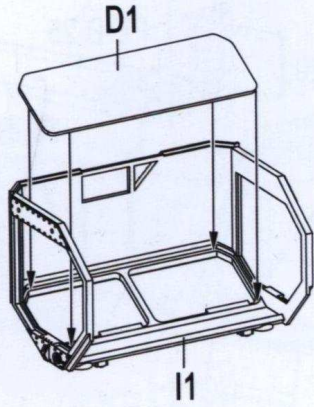

2 车头组装 2  
车头组装 2  
Attaching Cabin 2

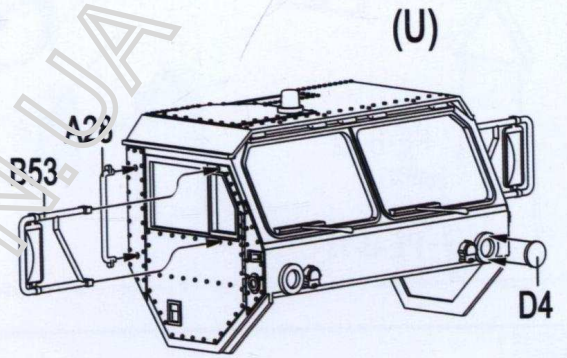
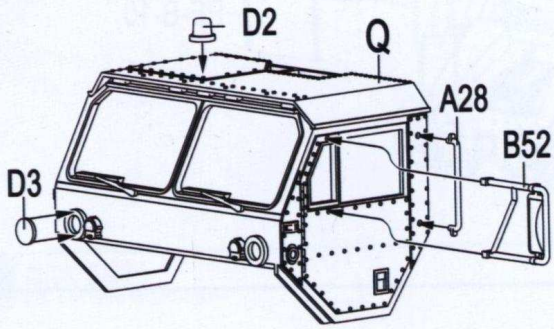

3 车头组装 3  
车头组装 3  
Attaching Cabin 3

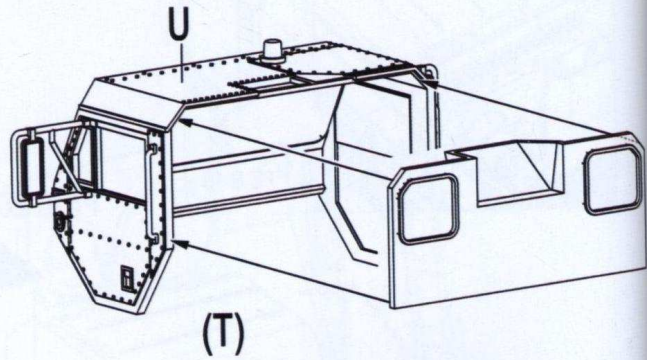
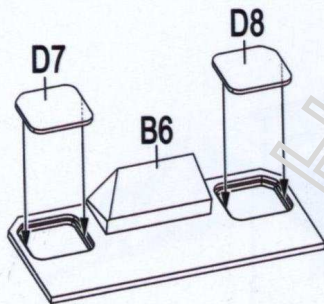

4 车头组装 4  
车头组装 4  
Attaching Cabin 4

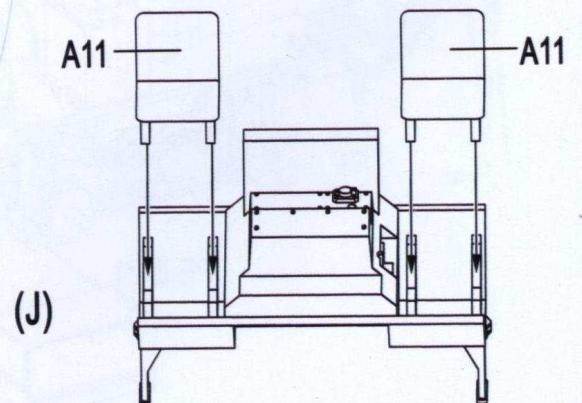
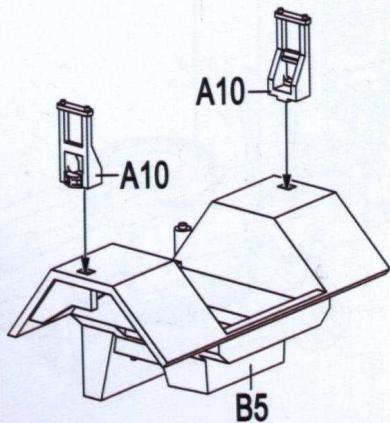



5

駕駛室組裝  
駕駛室組裝  
Attaching Cabin interior

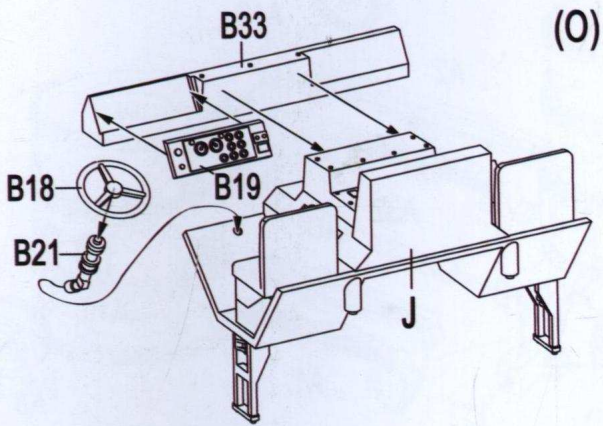

(O)

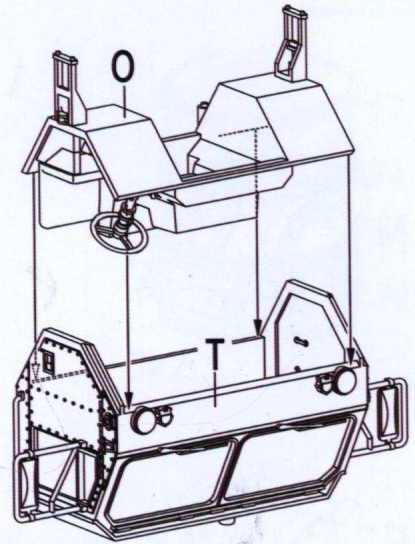

6

大梁組裝  
大梁組裝  
Attaching beam

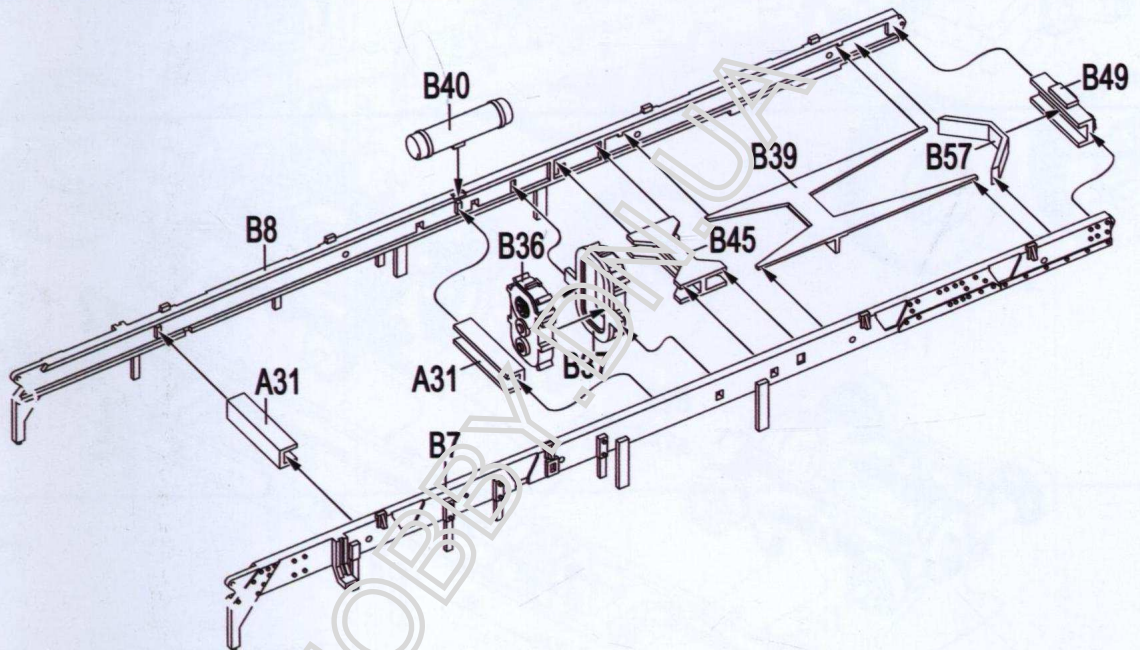

7

懸掛組裝 1  
懸掛組裝 1  
Attaching suspension 1

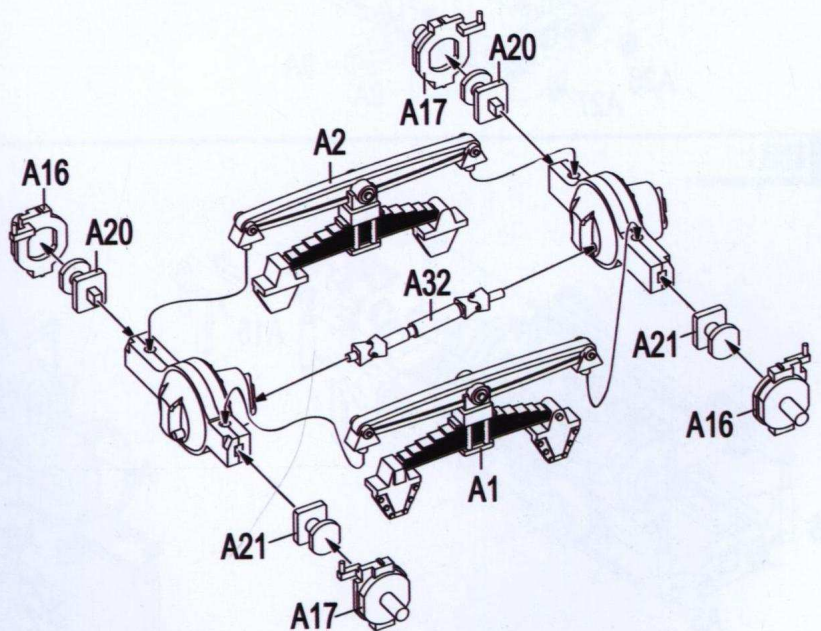
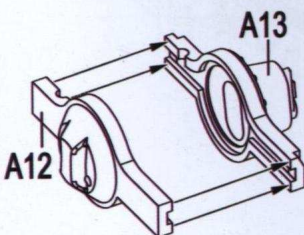
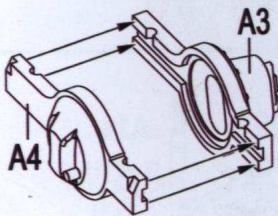

8

悬挂组装 2  
悬挂组装 2  
Attaching suspension 2

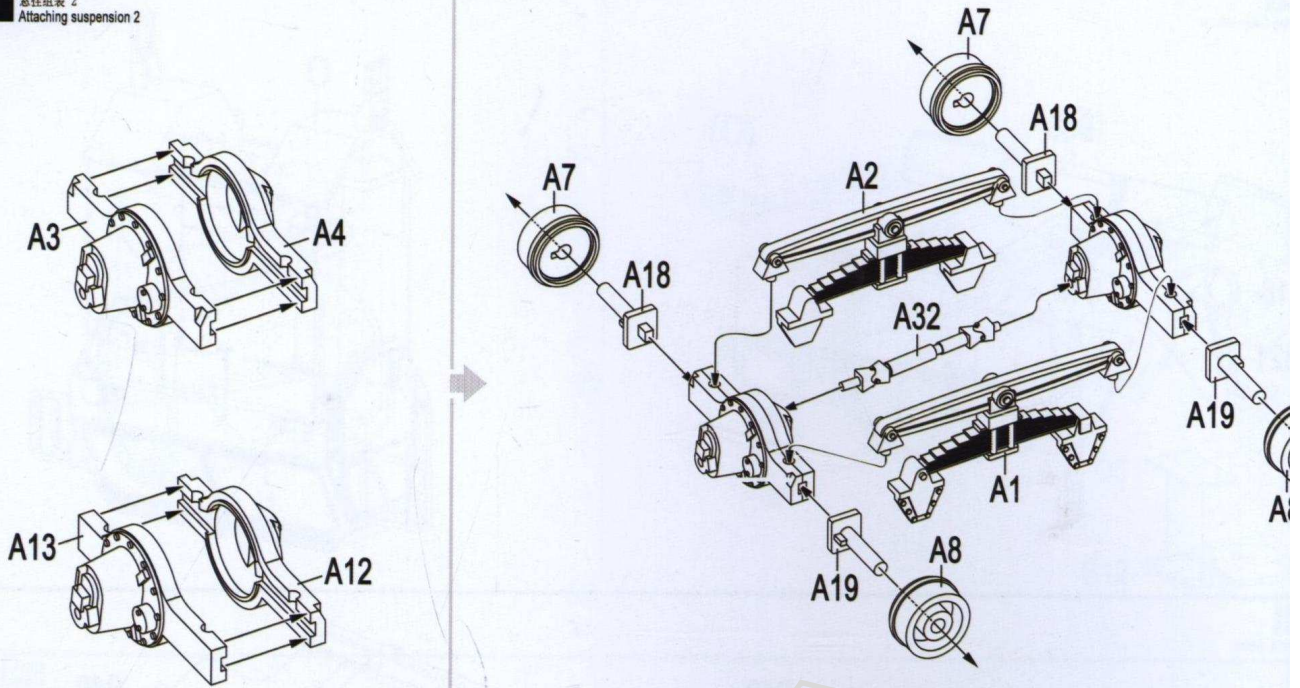

9

悬挂组装 3  
悬挂组装 3  
Attaching suspension 3

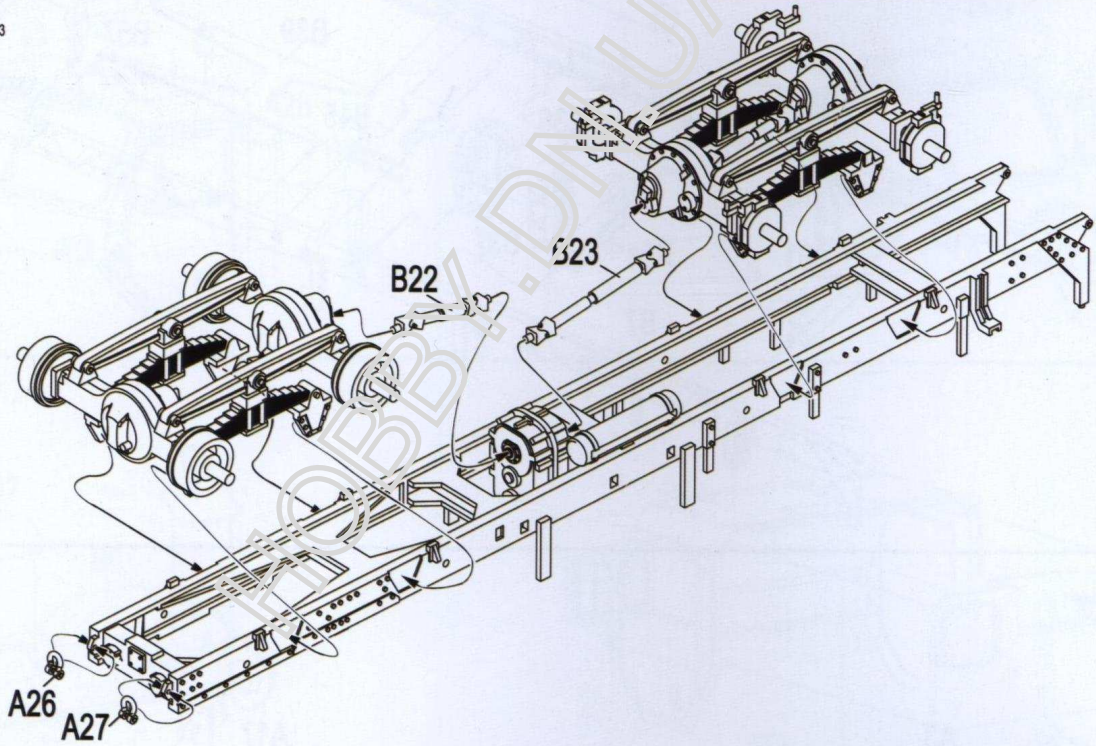

10

悬挂组装 4  
悬挂组装 4  
Attaching suspension 4

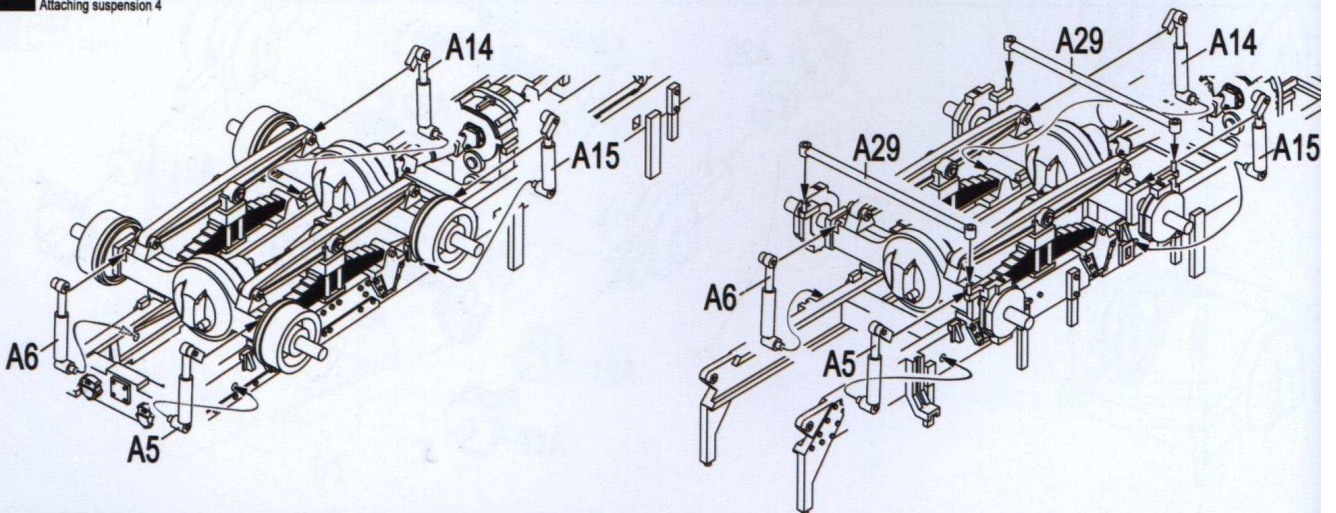

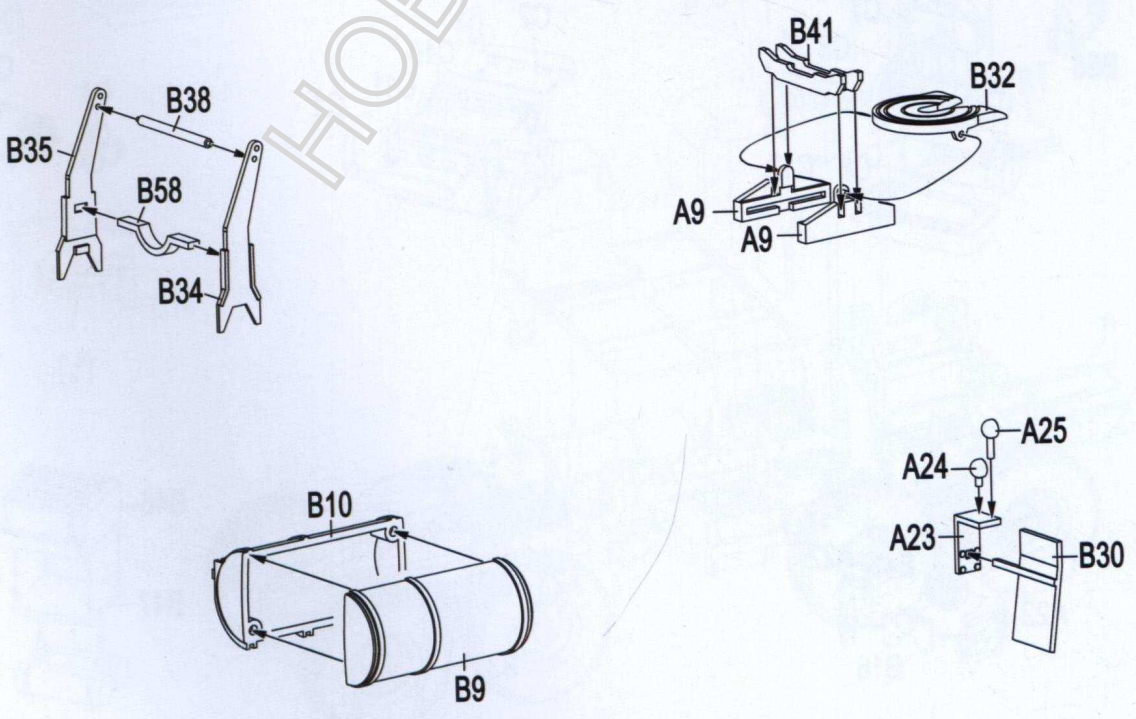
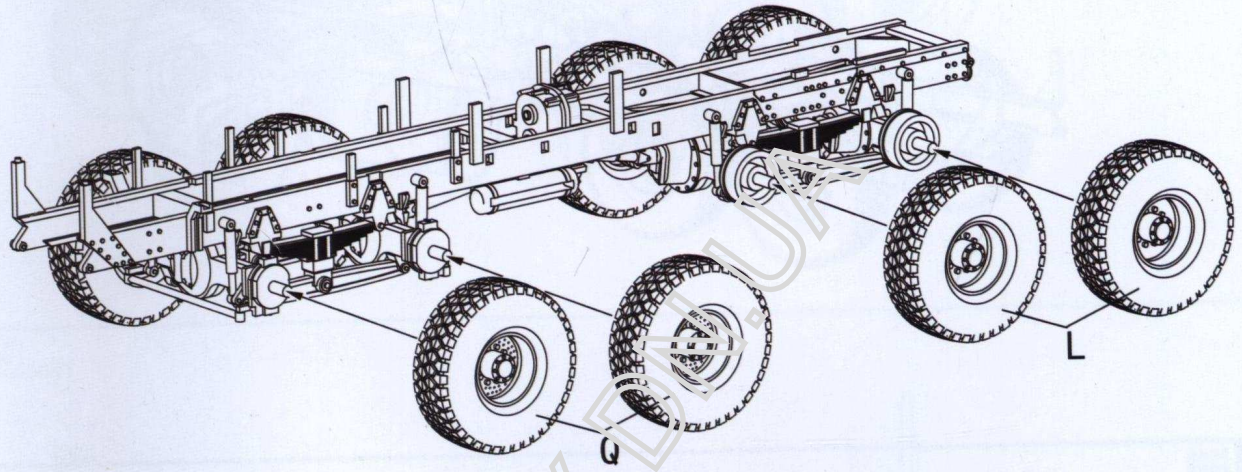
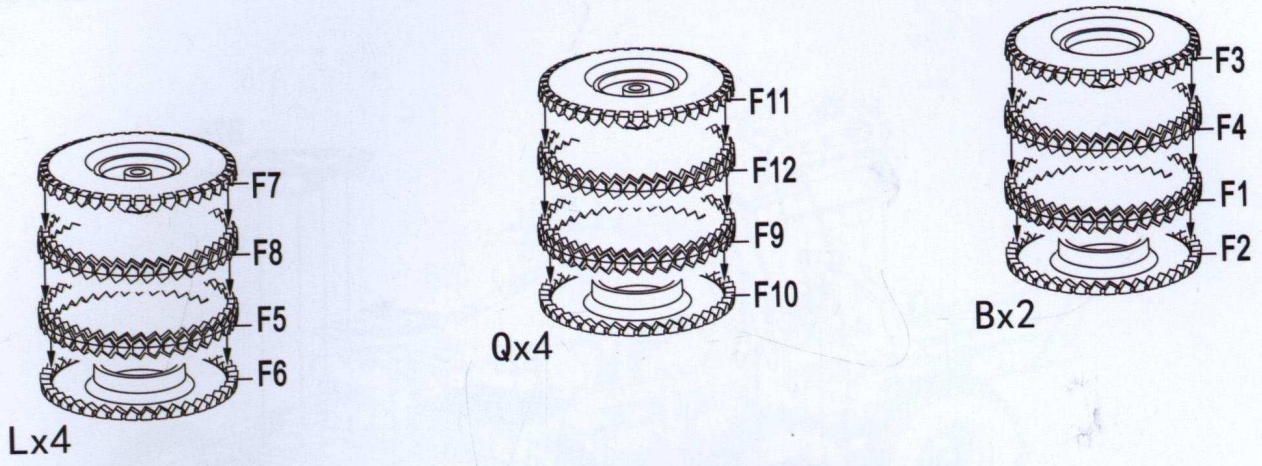

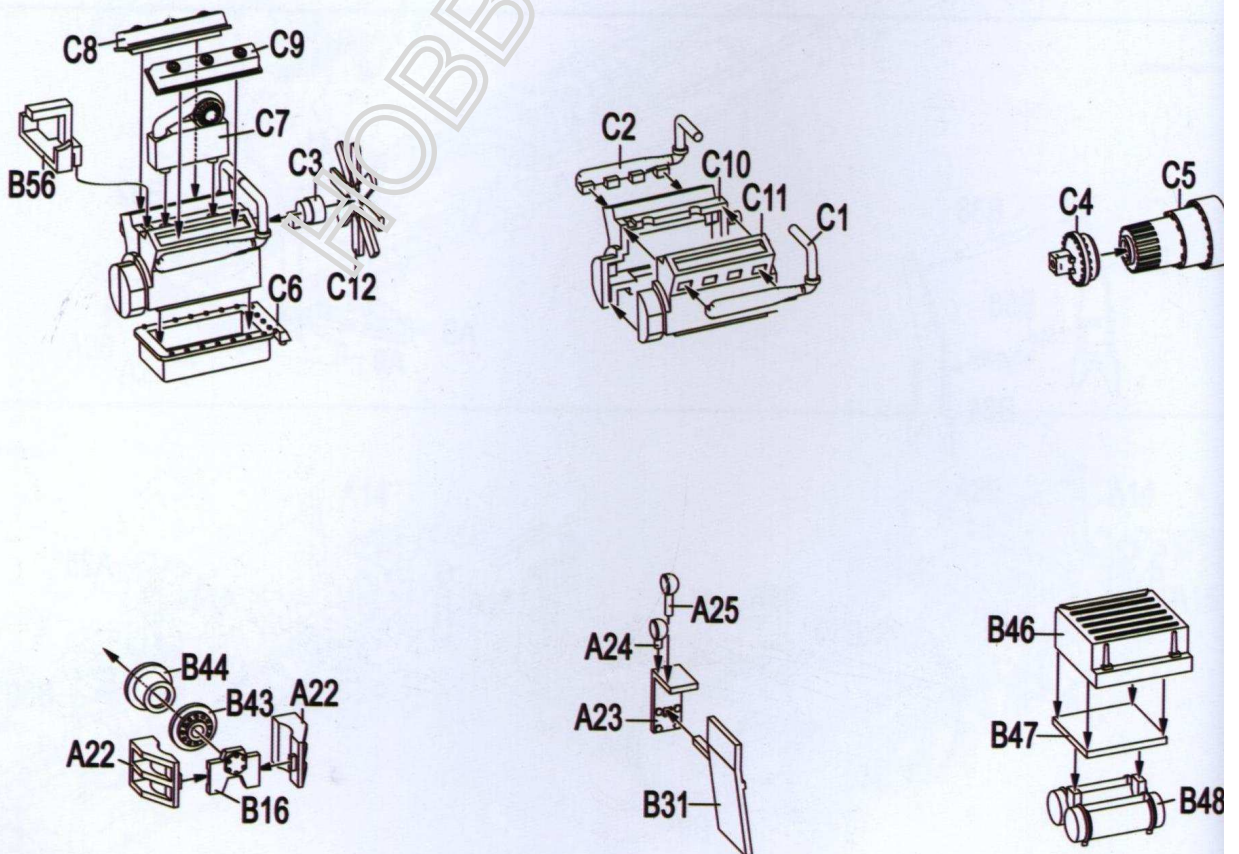
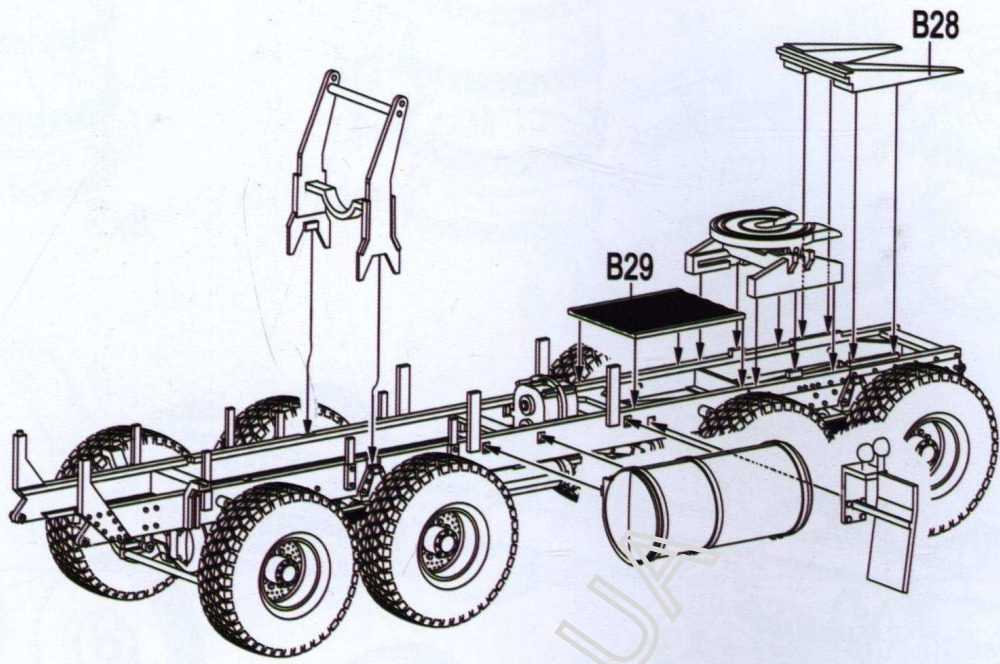

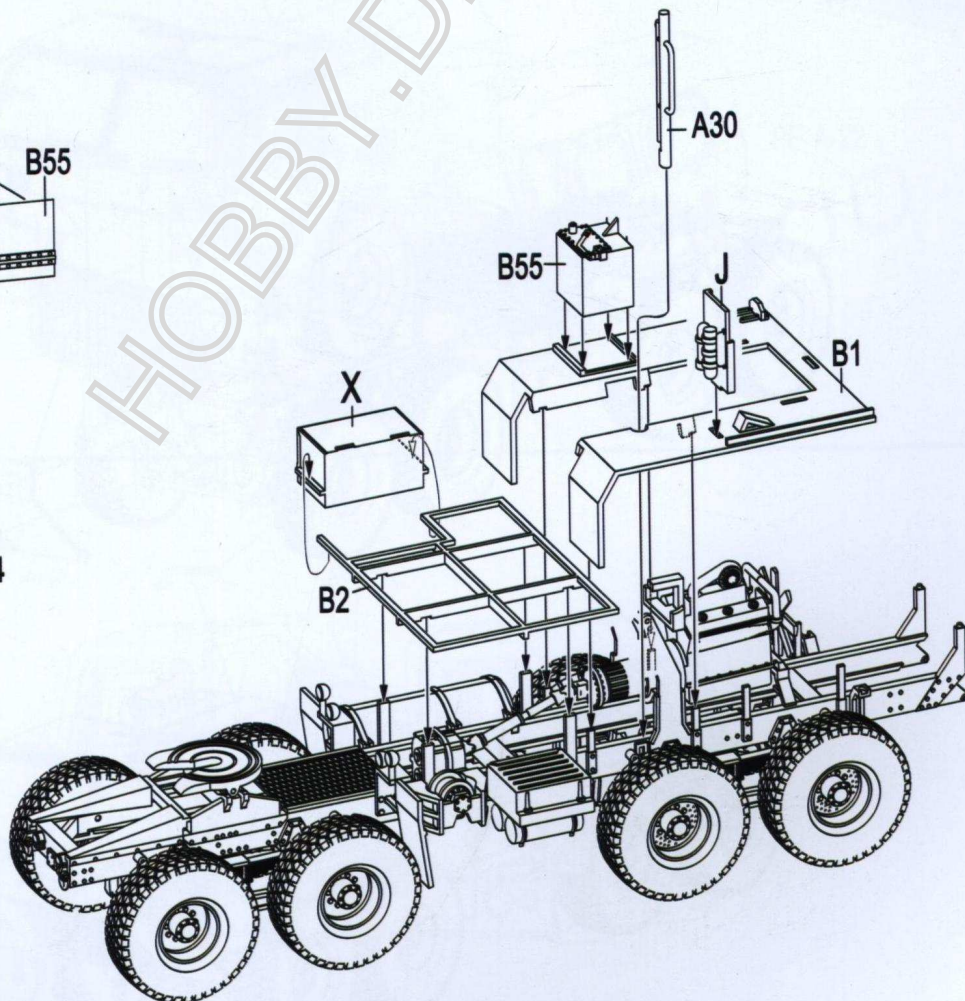
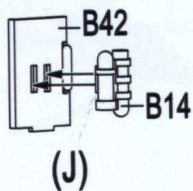
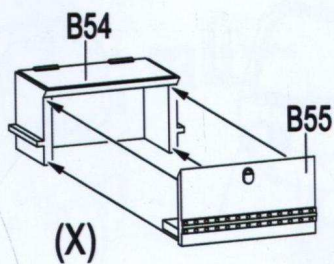
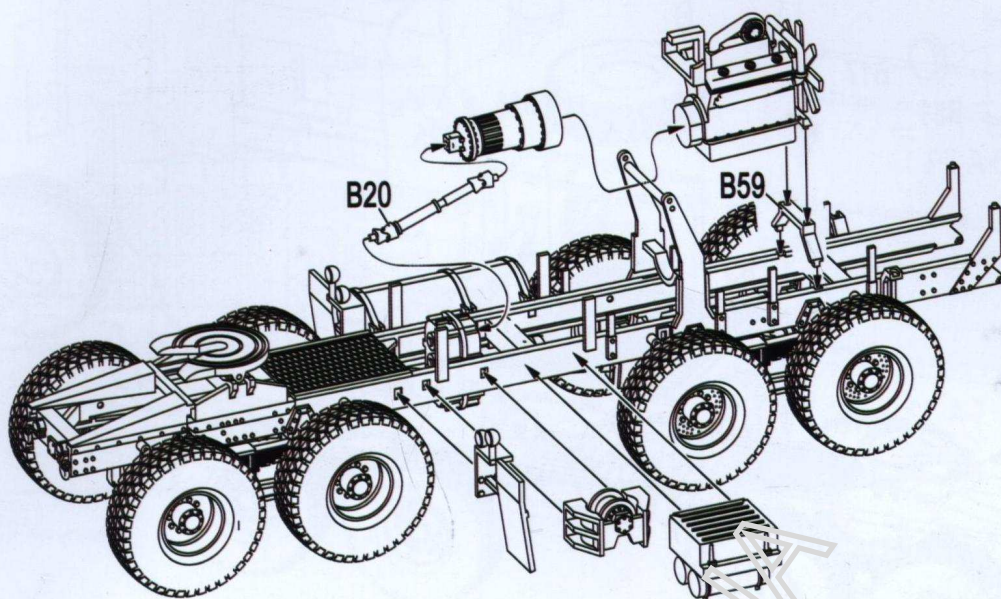

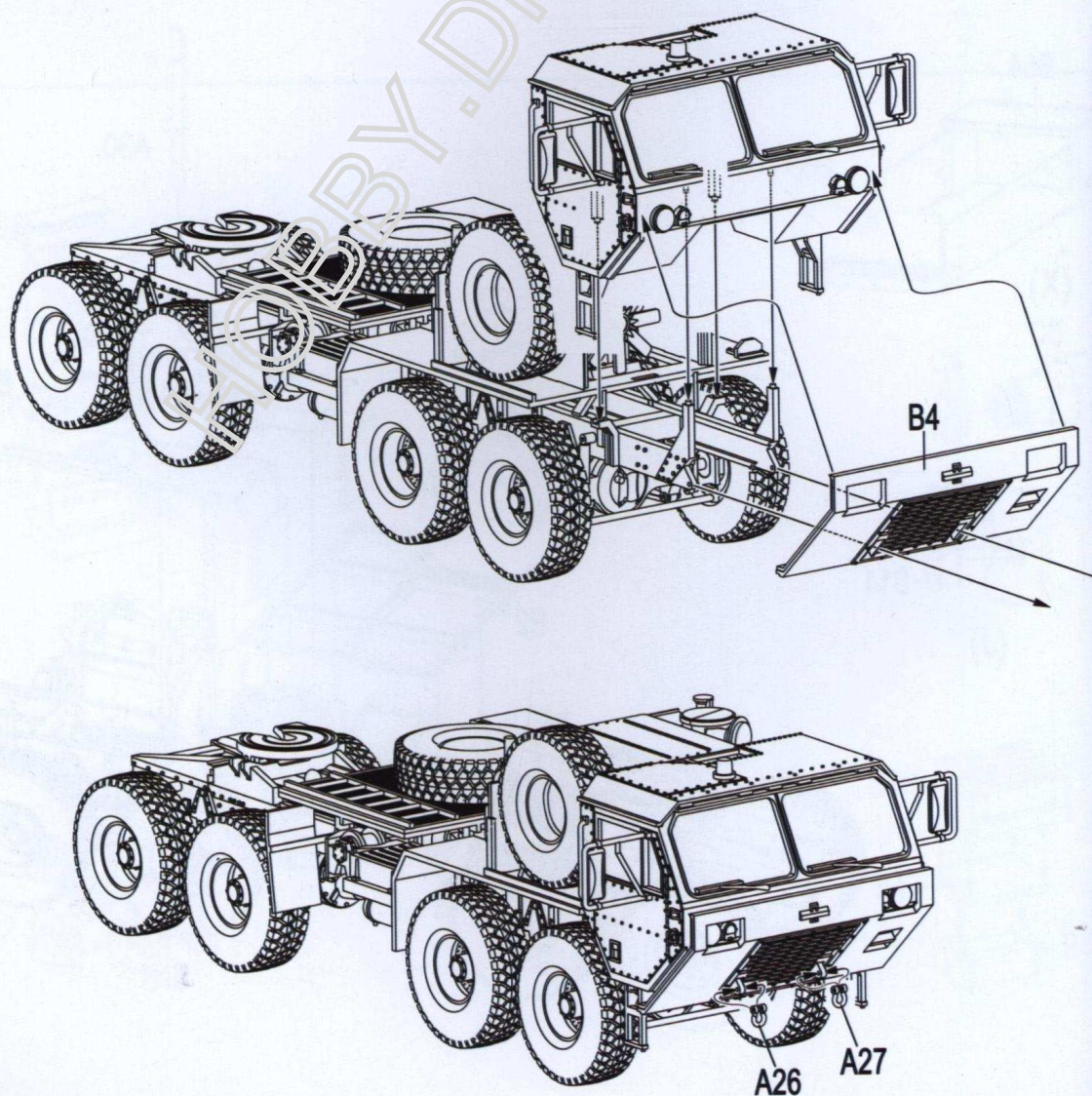
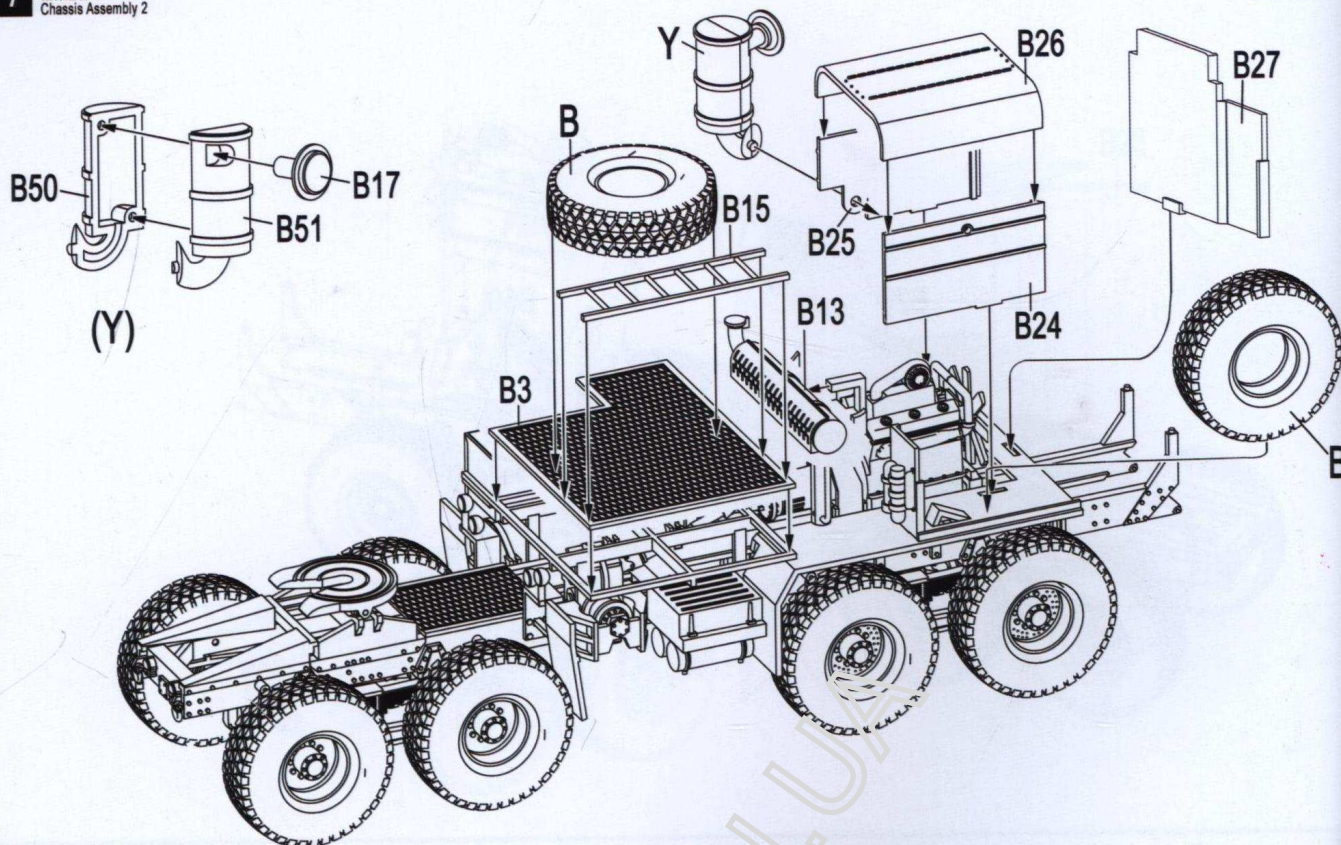

1 MAZ车头PE细节改造 1  
MAZ車頭PE細節改造 1  
MAZ driver cabin detail set update 1

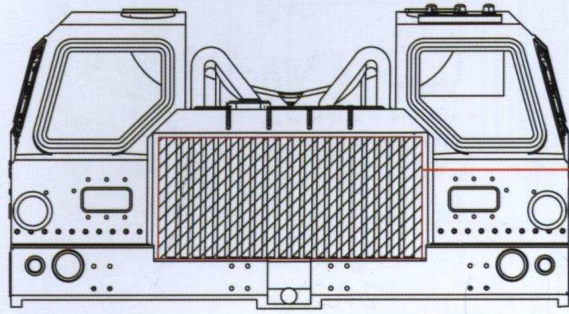

CUT/REMOVE  
切除

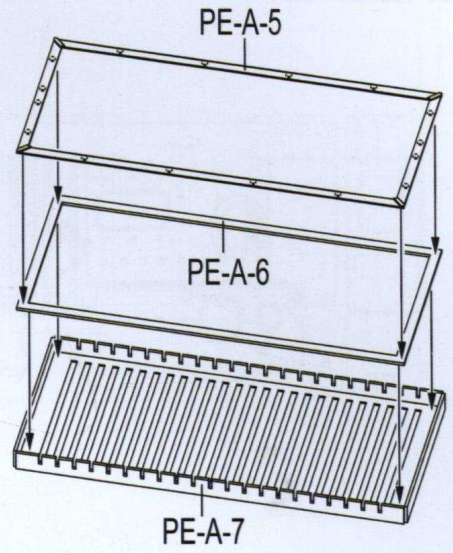

2 MAZ车头PE细节改造 2  
MAZ車頭PE細節改造 2  
MAZ driver cabin detail set update 2

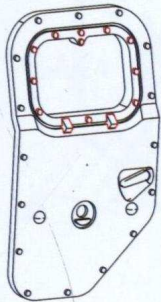
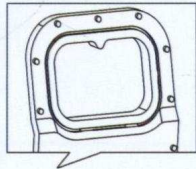

CUT/REMOVE  
切除

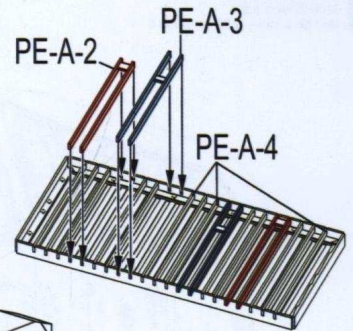
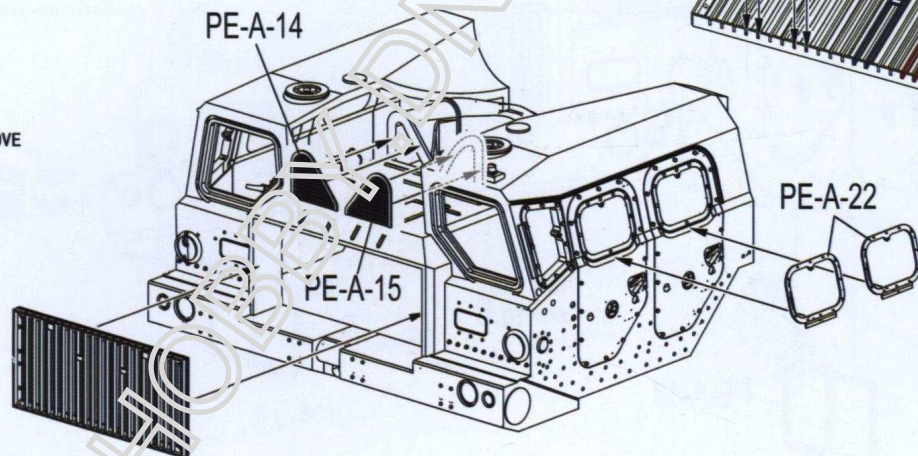

3 MAZ车头PE细节改造 3  
MAZ車頭PE細節改造 3  
MAZ driver cabin detail set update 3

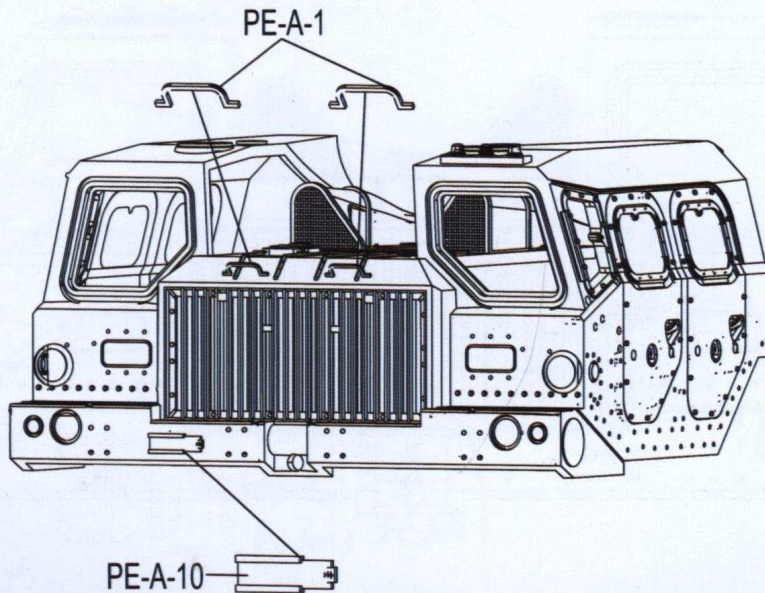

4

MAZ车头PE细节改造 4  
MAZ车头PE细节改造 4  
MAZ driver cabin detail set update 4

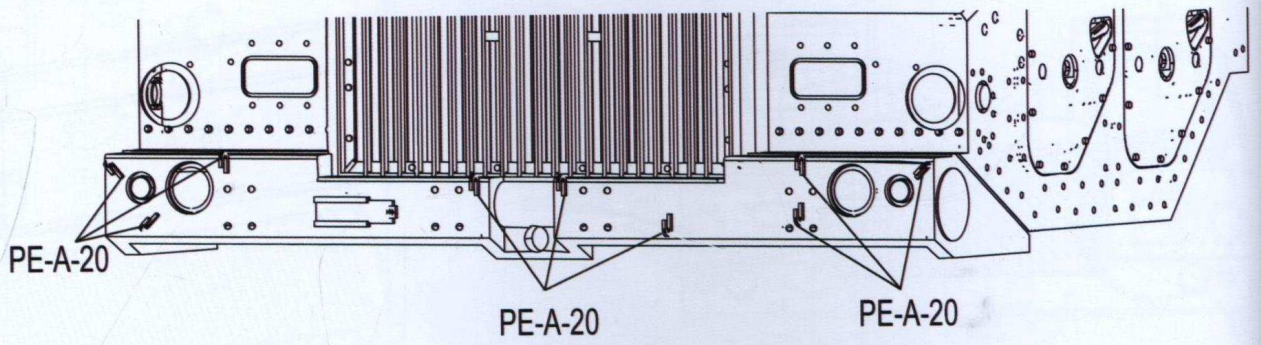

5

MAZ车头PE细节改造 5  
MAZ车头PE细节改造 5  
MAZ driver cabin detail set update 5

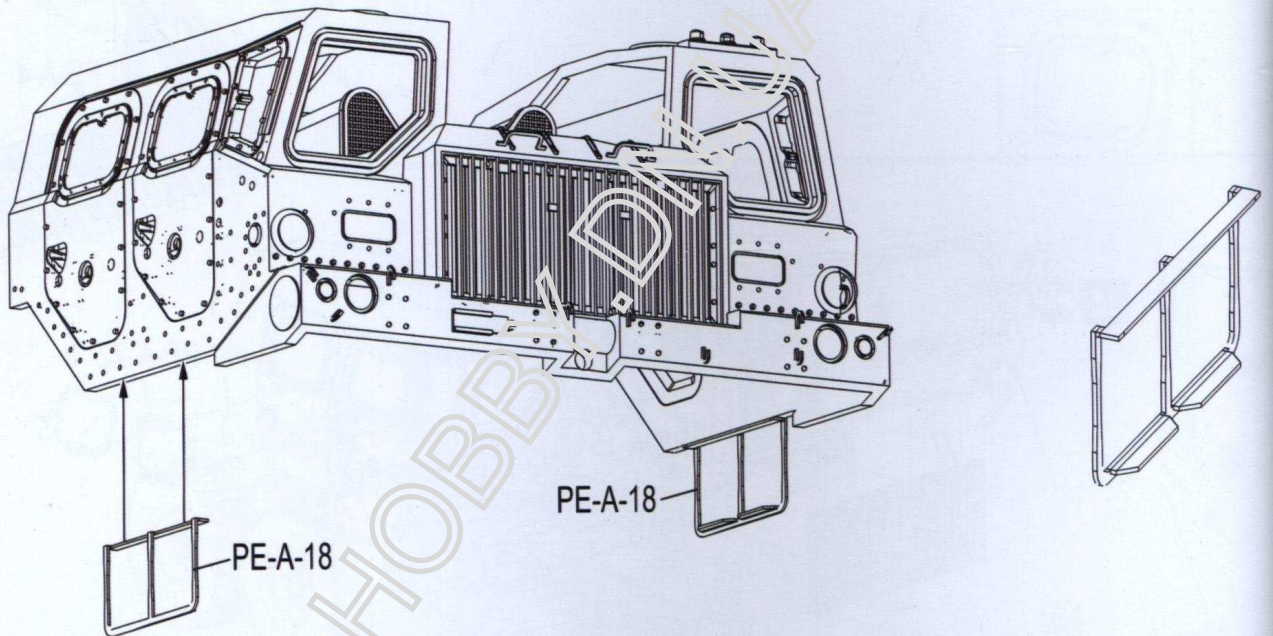

6

MAZ车头PE细节改造 6  
MAZ车头PE细节改造 6  
MAZ driver cabin detail set update 6

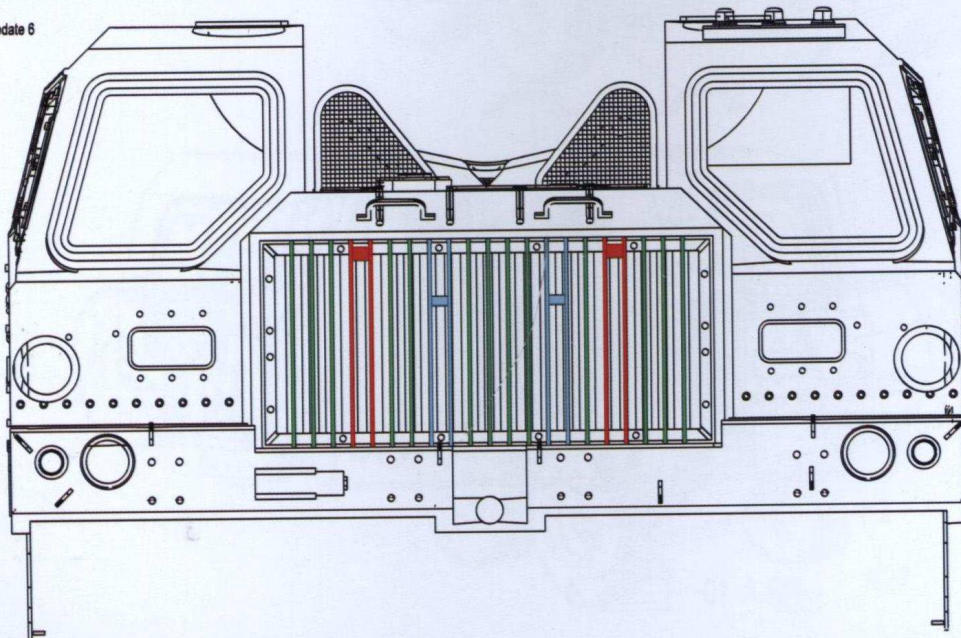



7

动力舱PE细节改造 1  
動力舱PE細節改造 1  
MAZ engine carbin detail set update 1

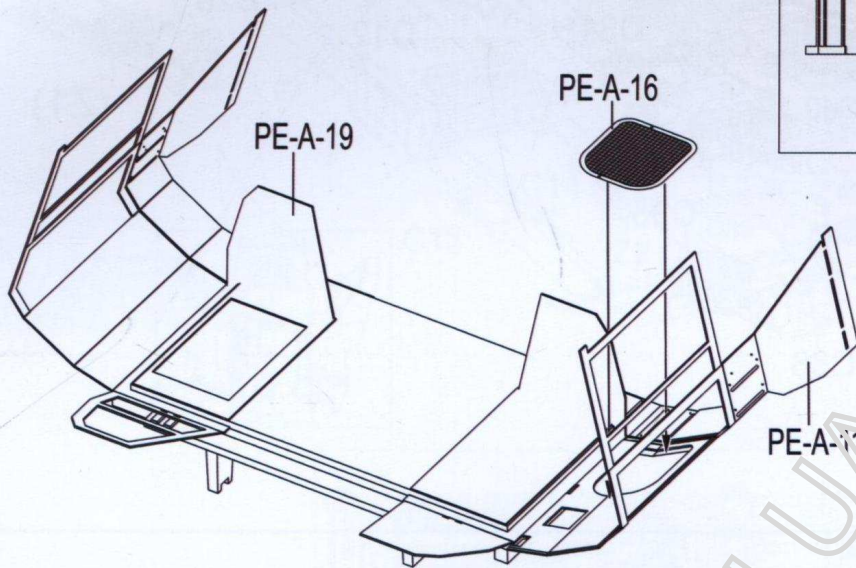

8

动力舱PE细节改造 2  
動力舱PE細節改造 2  
MAZ engine carbin detail set update 2

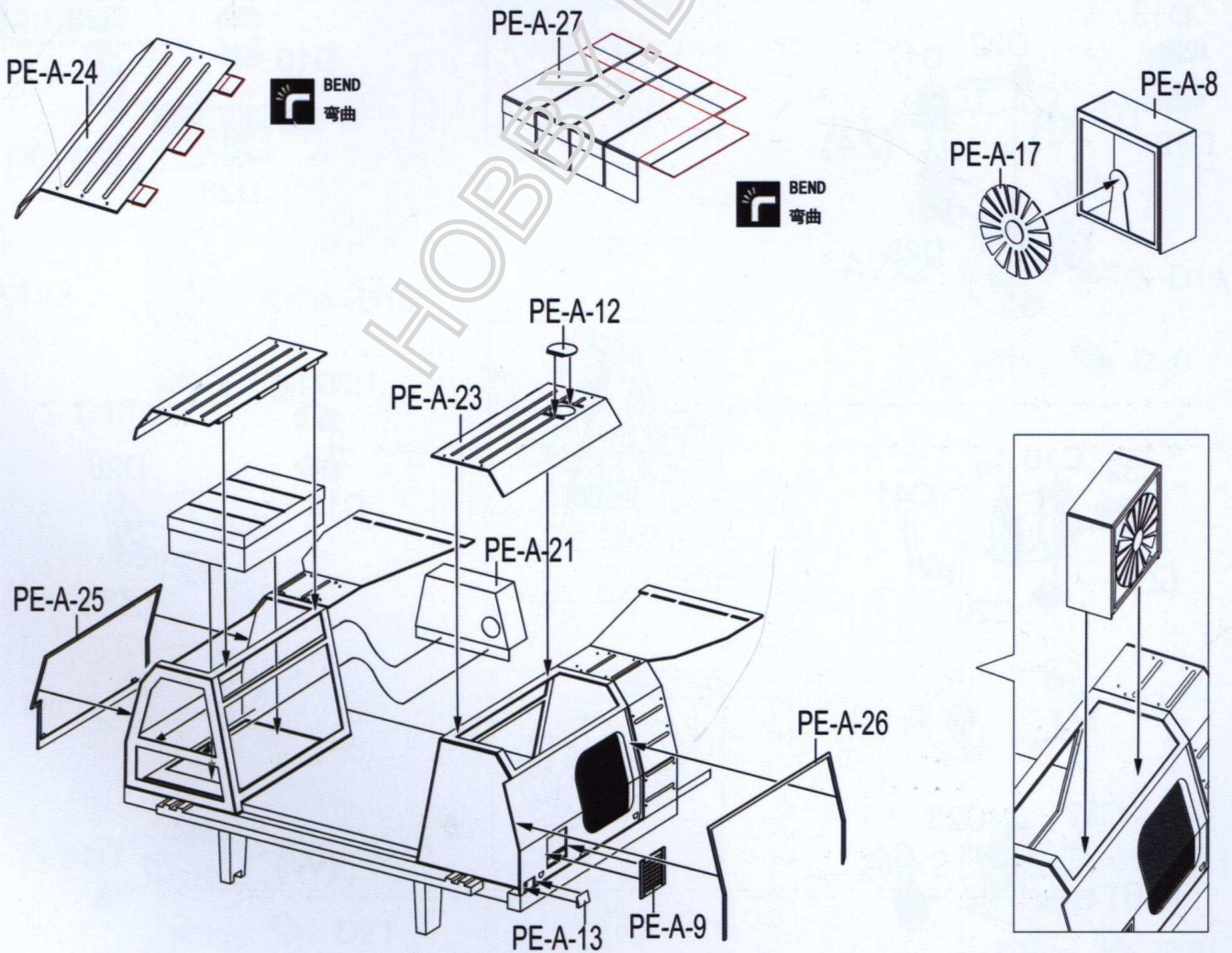

1

发动机及传动结构组装  
發動機及傳動結構組裝  
Attaching engine part and transmission system

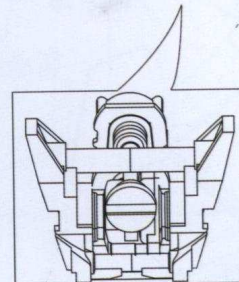
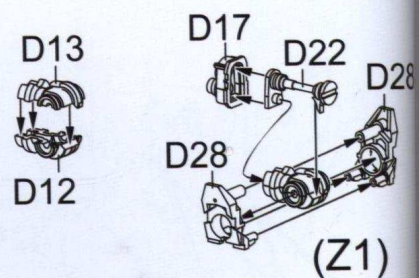
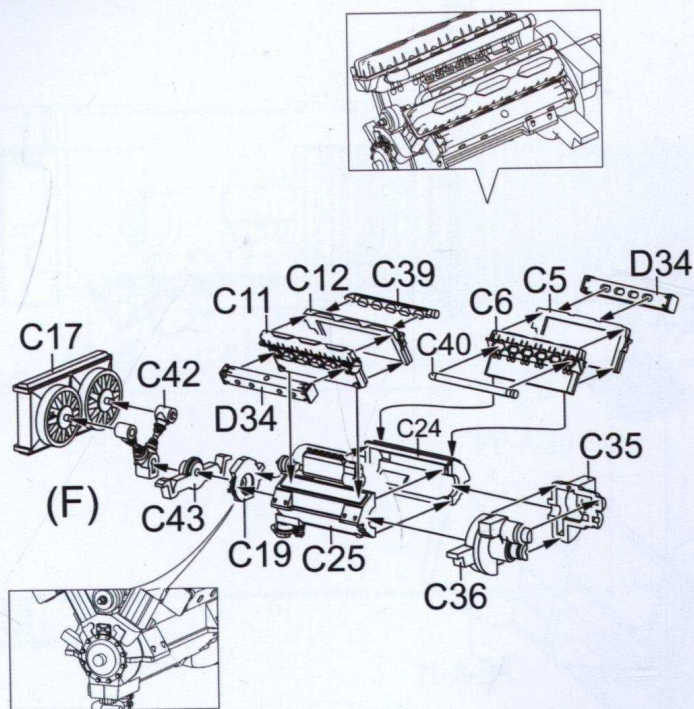

2

发动机及传动结构组装  
發動機及傳動結構組裝  
Attaching engine part and transmission system

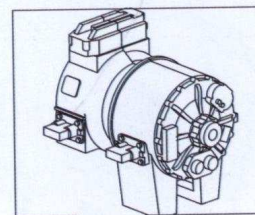
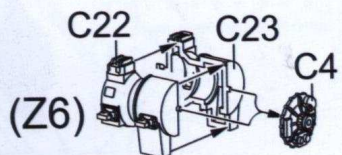
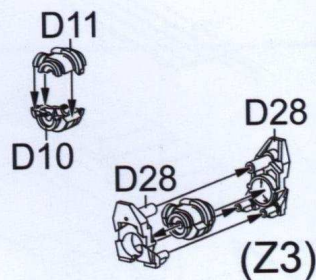
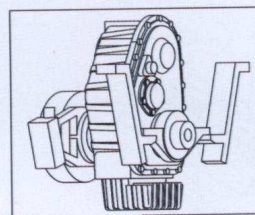
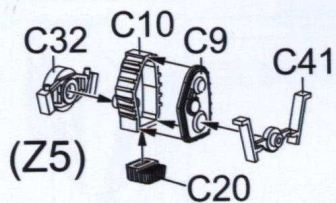
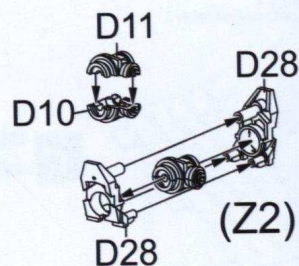
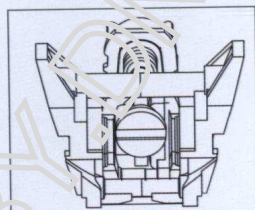
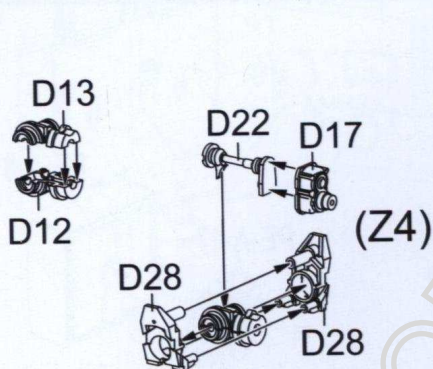

3

车体大梁附件组装  
車體大梁附件組裝  
Attaching crossbeam detail part

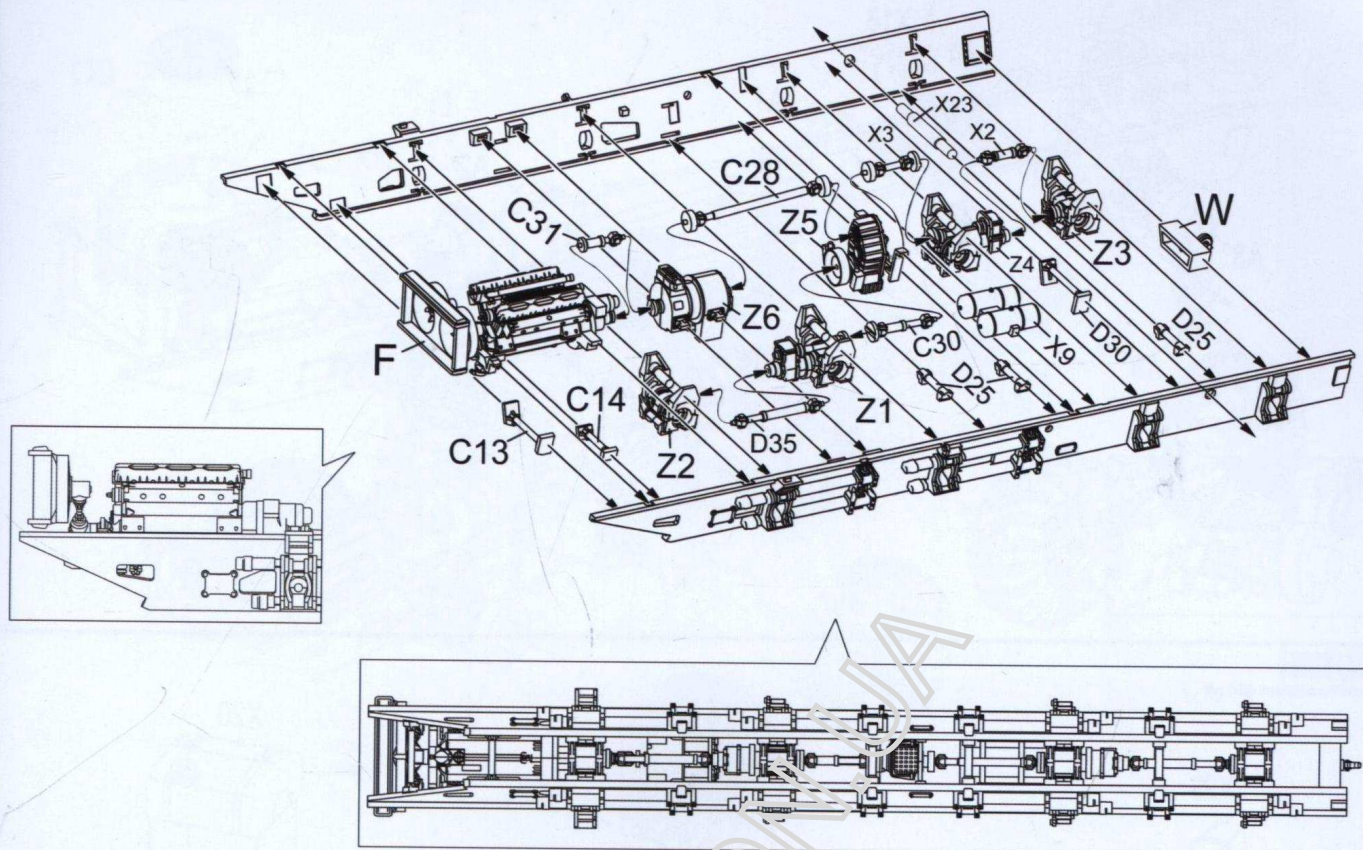

4

车体大梁及悬挂结构组装  
車體大梁及懸掛結構組裝  
Attaching crossbeam and suspension

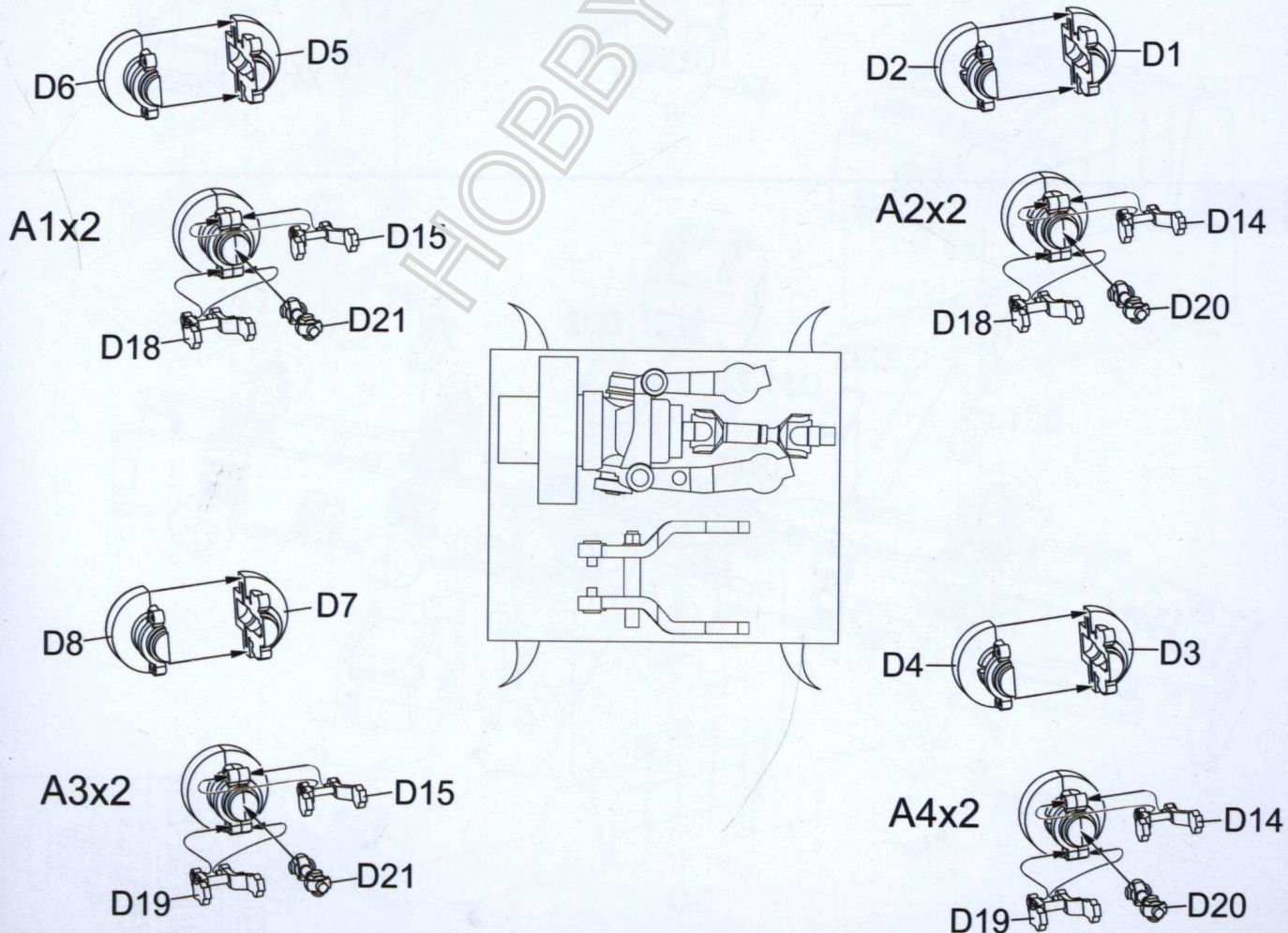

5

车体大梁及悬挂结构组装  
車體大梁及懸掛結構組裝  
Attaching crossbeam and suspension

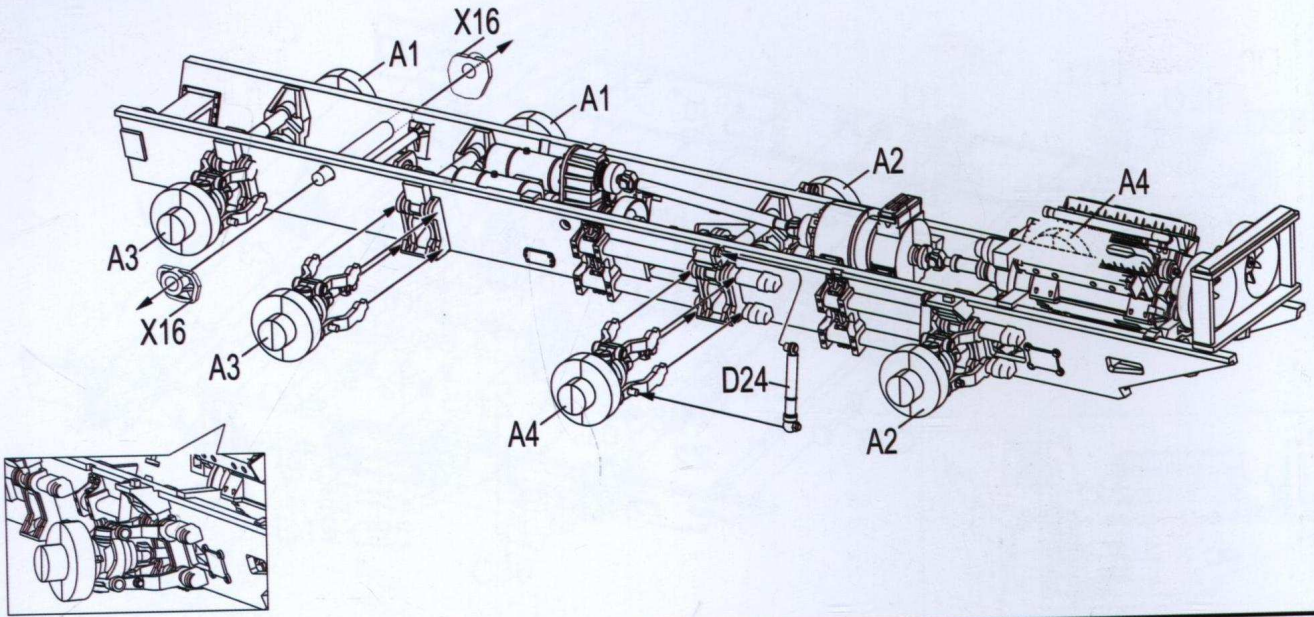

6

车体大梁附件组装  
車體大梁附件組裝  
Attaching crossbeam detail part

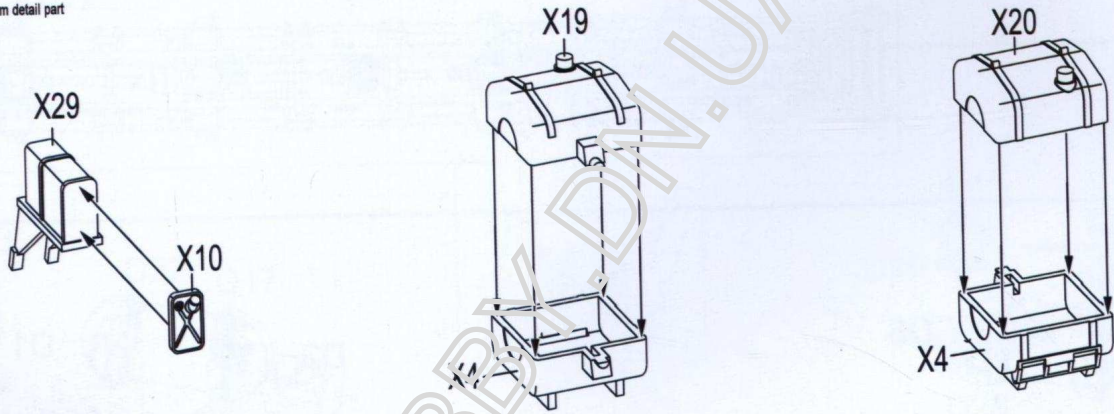

7

车体大梁附件组装  
車體大梁附件組裝  
Attaching crossbeam detail part

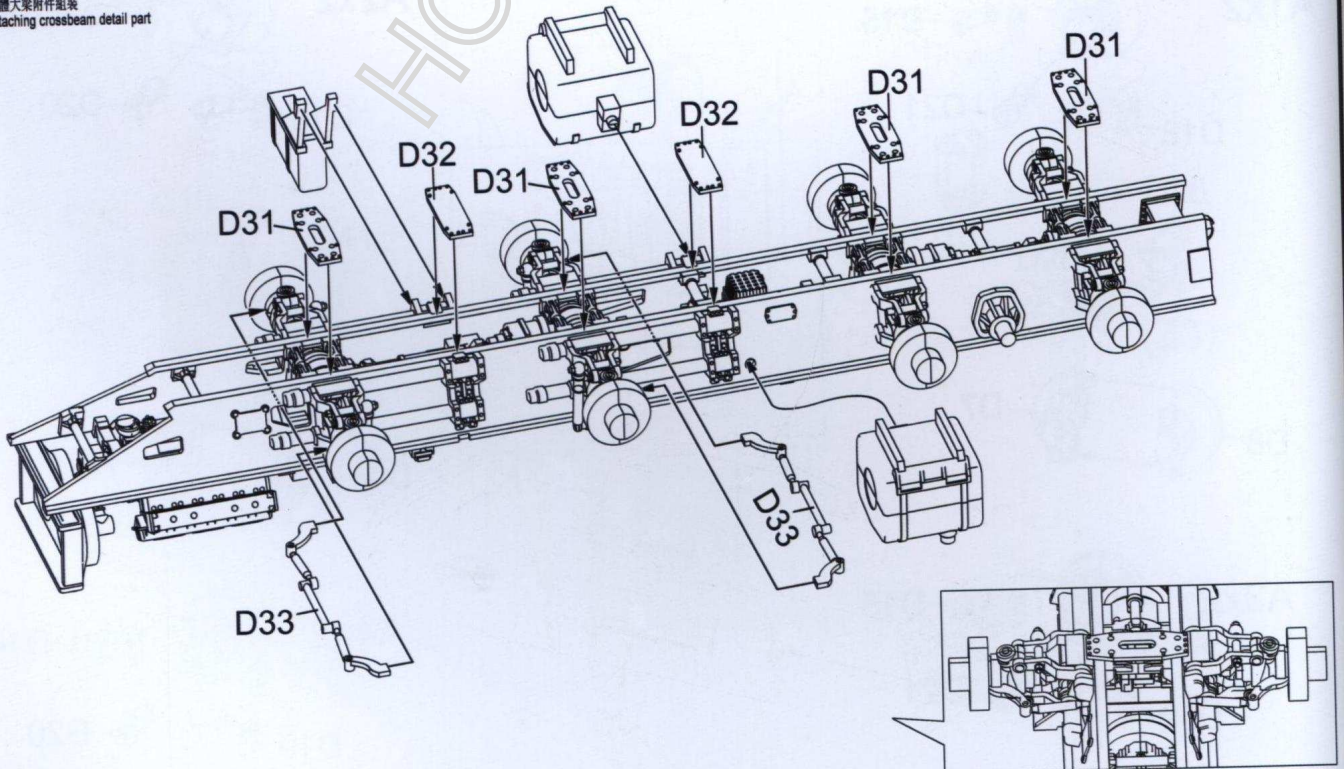

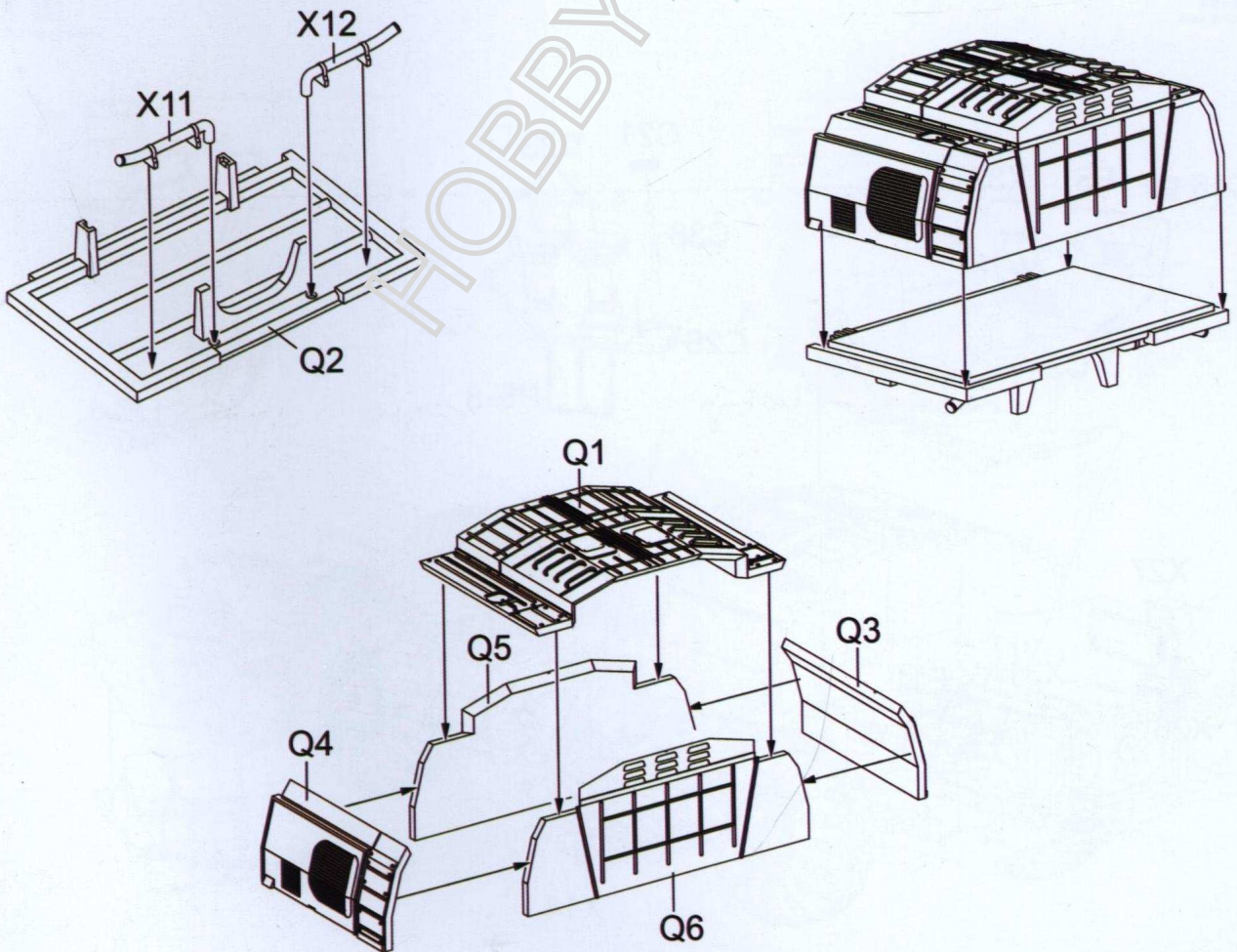
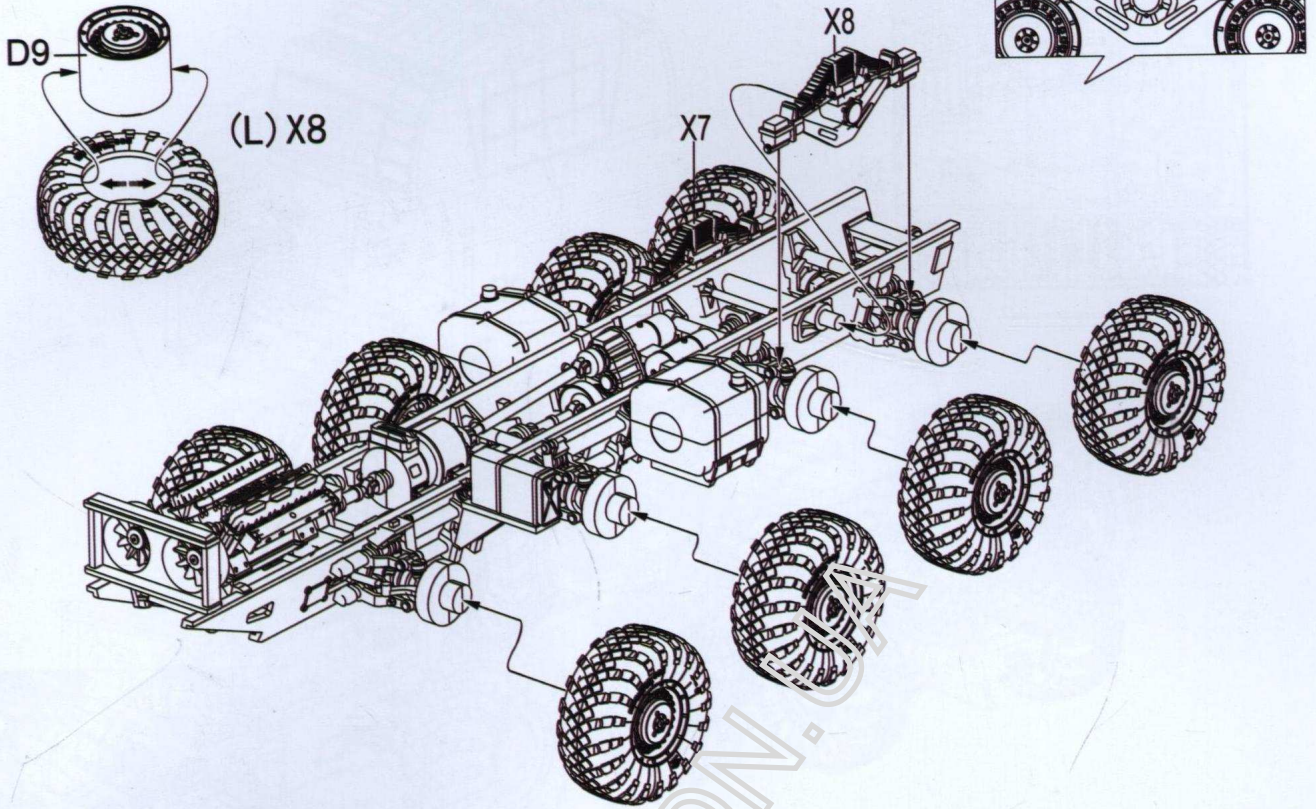

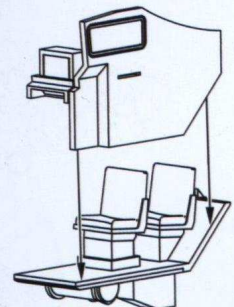
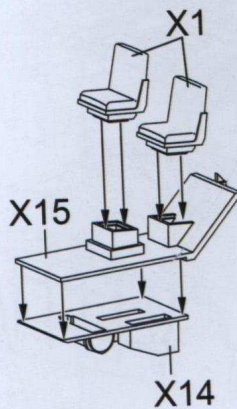
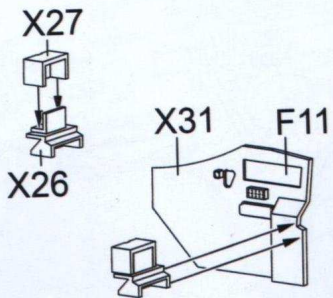
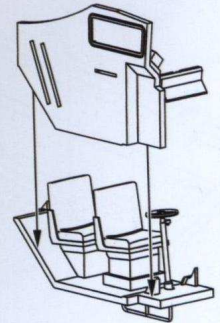
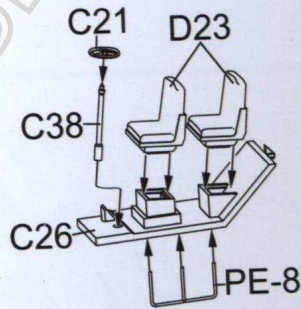
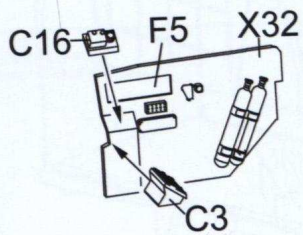
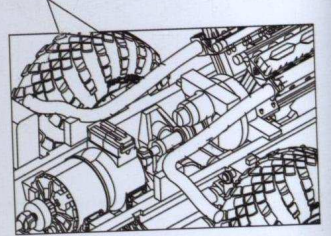
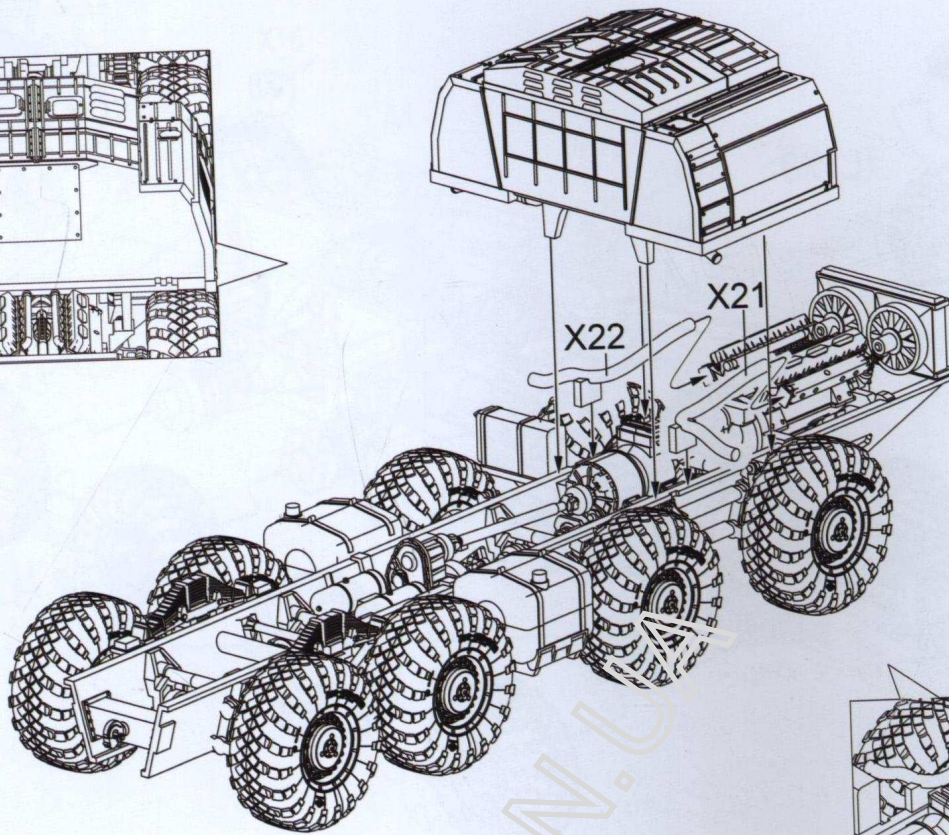
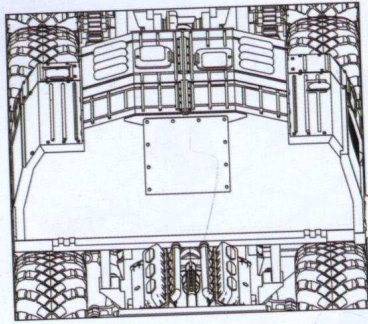

12

组装左驾驶室  
组装左驾驶室  
Attaching left cabin

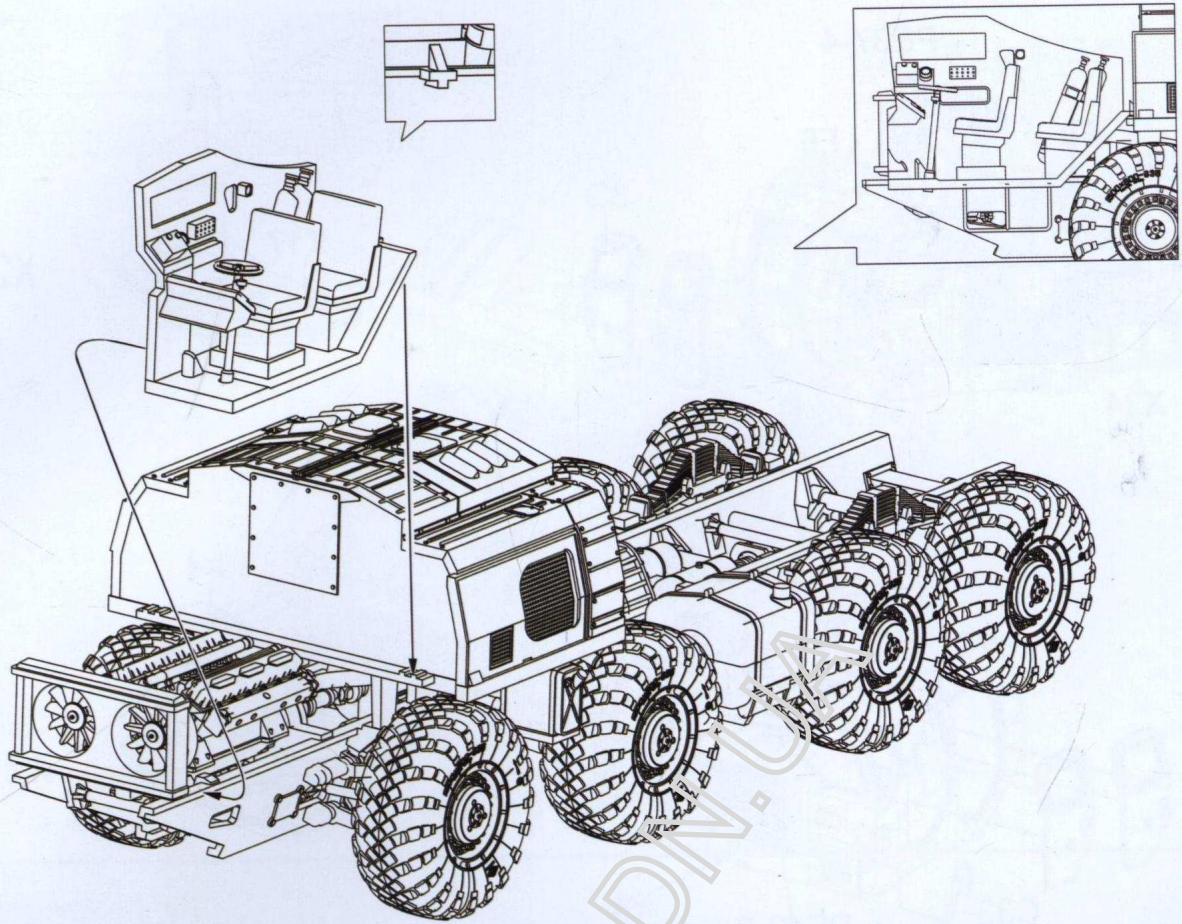

13

组装右驾驶室  
组装右驾驶室  
Attaching right cabin

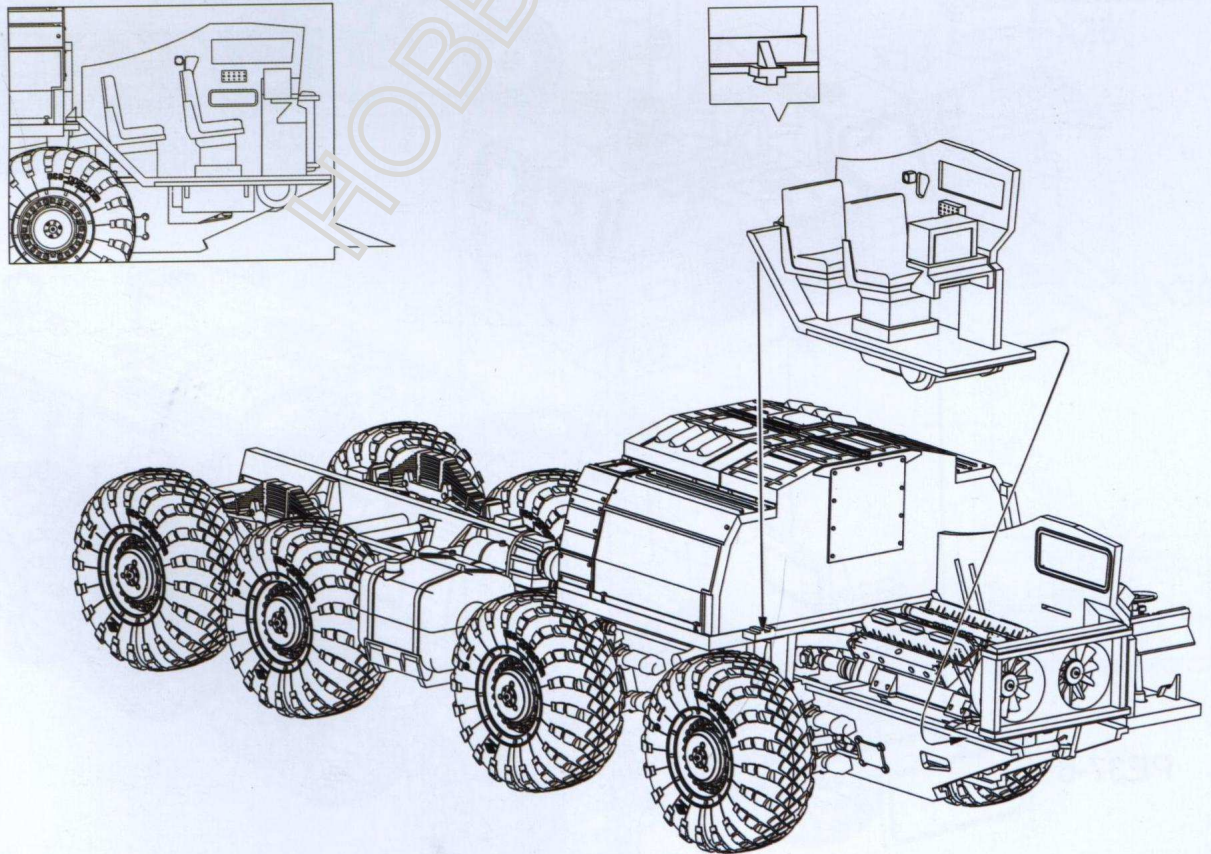

14 组装驾驶室外部  
 组装驾驶室外部  
 Attaching cabin details

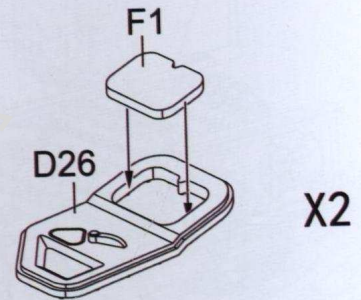
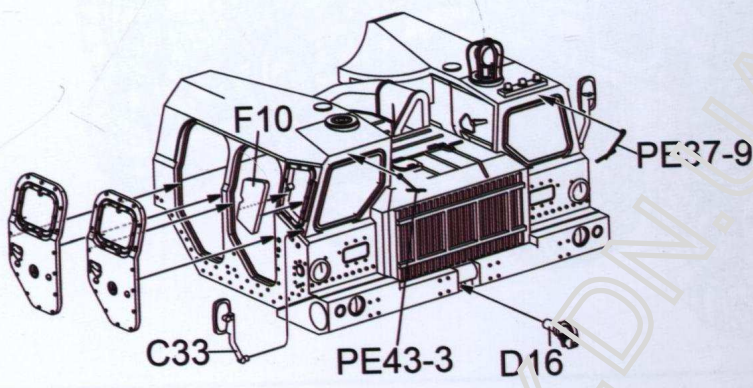
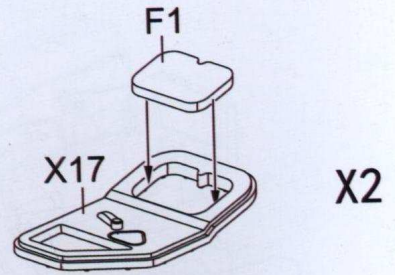
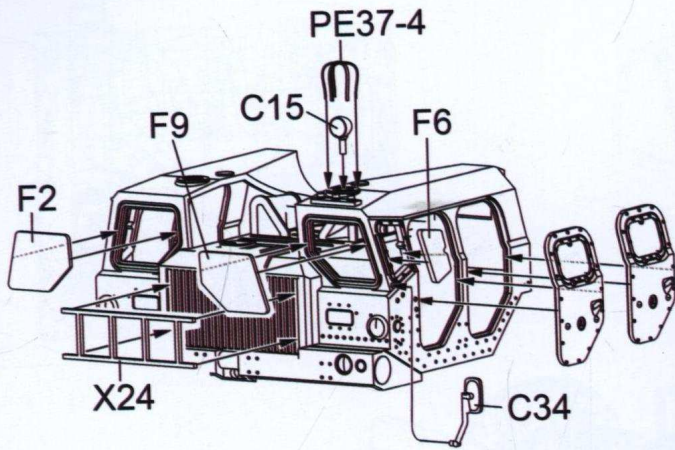

15 组装驾驶室与车体  
 组装驾驶室与车体  
 Attaching cabin and crossbeam

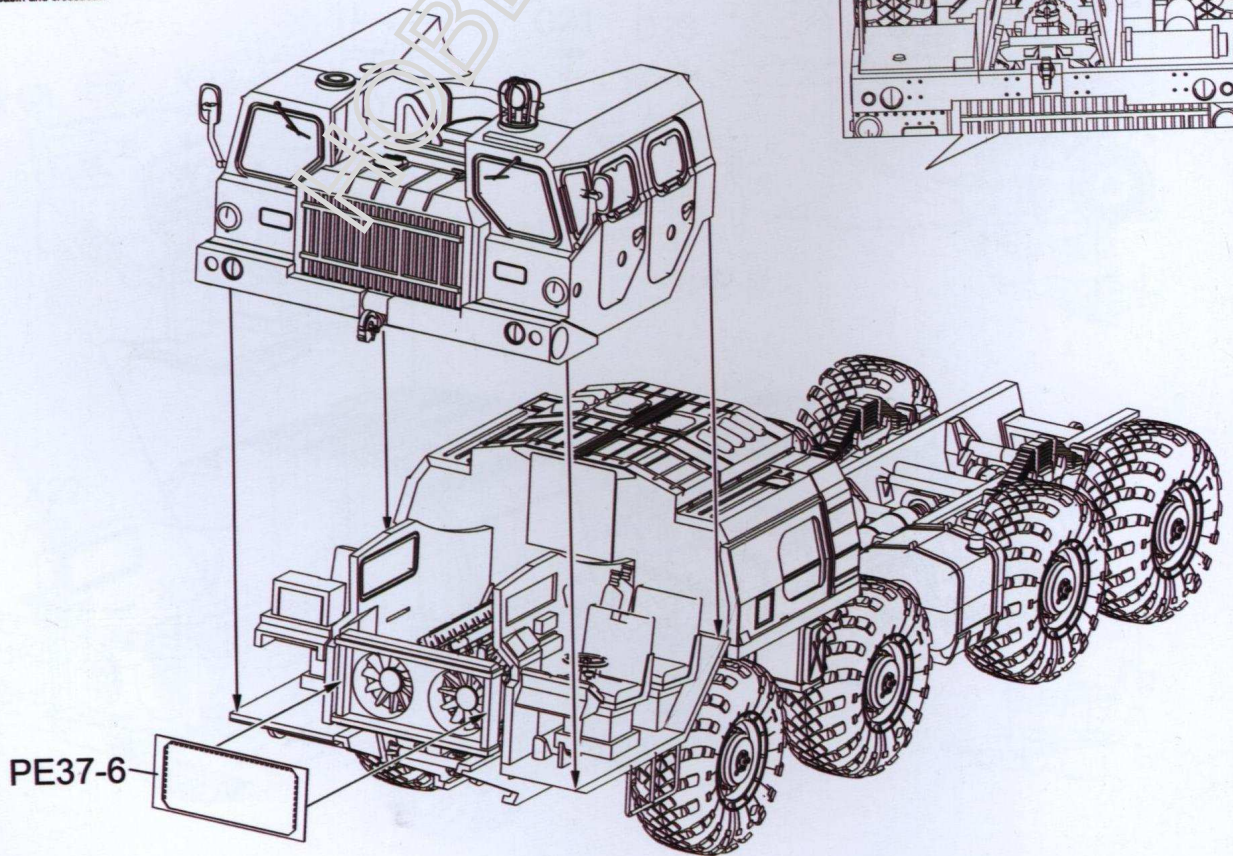



16

组装前底盘挡板  
组装前底盘撑板  
Attaching front crossbeam detail

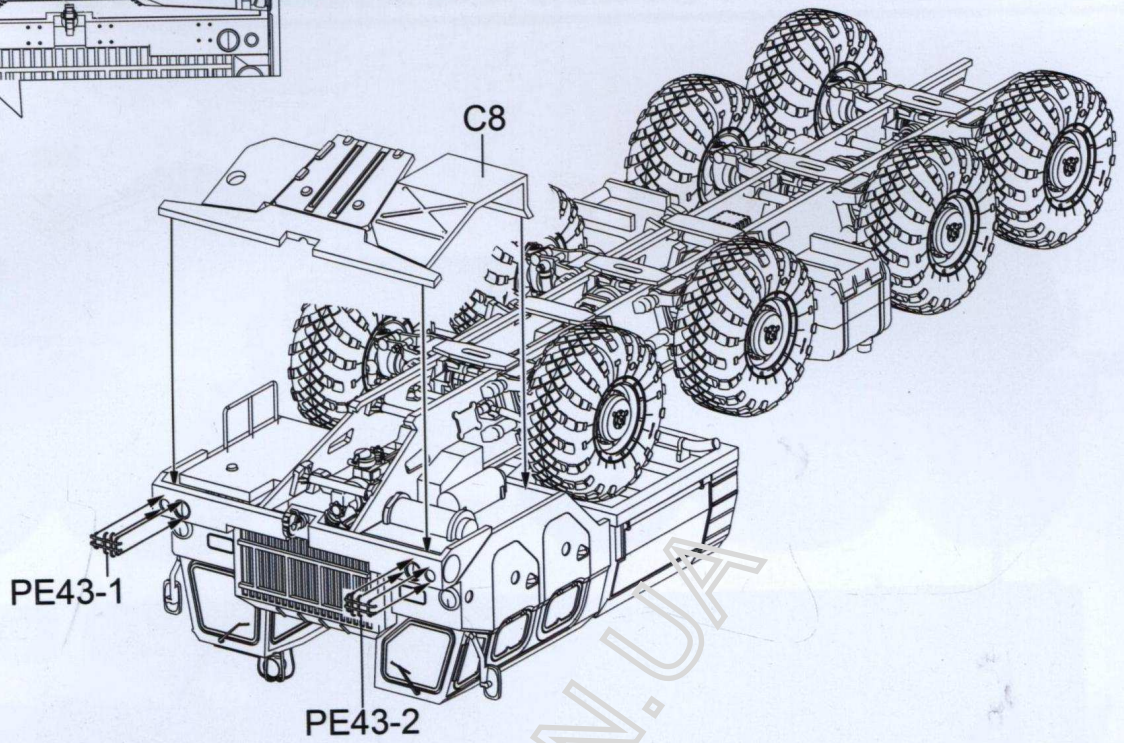
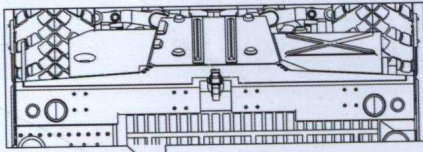

17

组装拖车挂钩  
组装拖车挂钩  
Attaching hook to the truck.

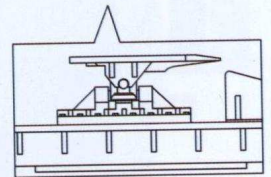
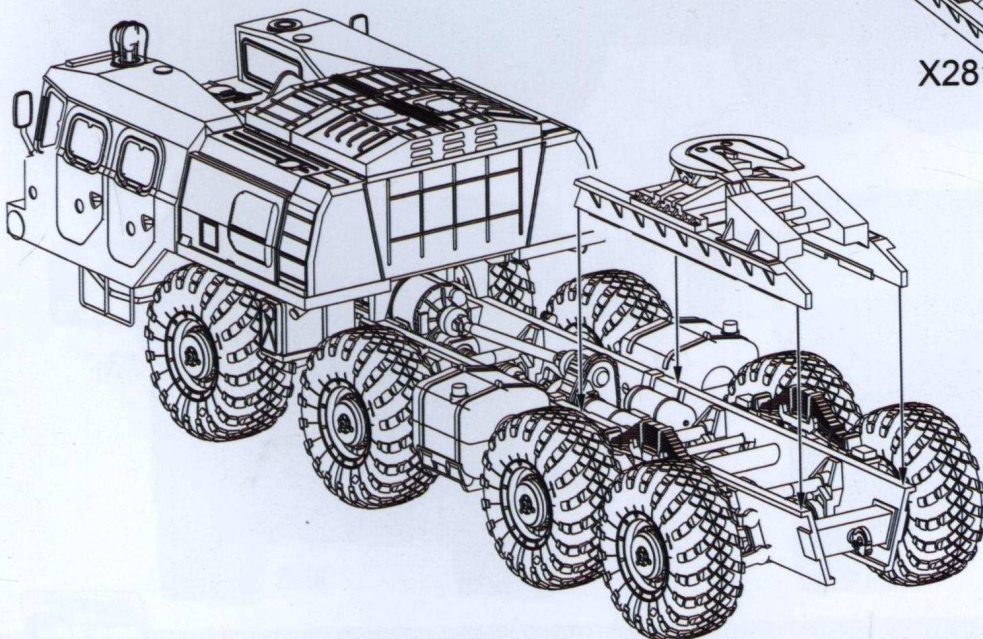
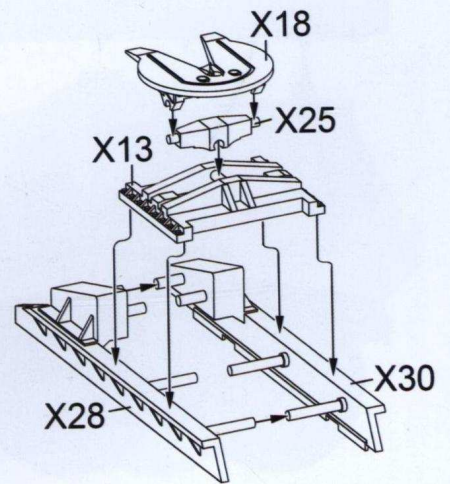
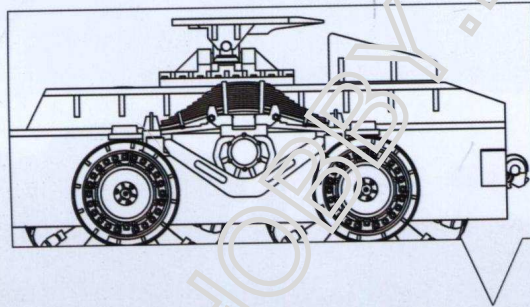

# USA M983A2 HEMTT TRACTOR

modelcollect

A.MIG 097 Crystal Orange

A.MIG 081 Olive Drab

A.MIG 033 Rubber & Tires

A.MIG 094 Crystal Glass

A.MIG 915 Dark Green

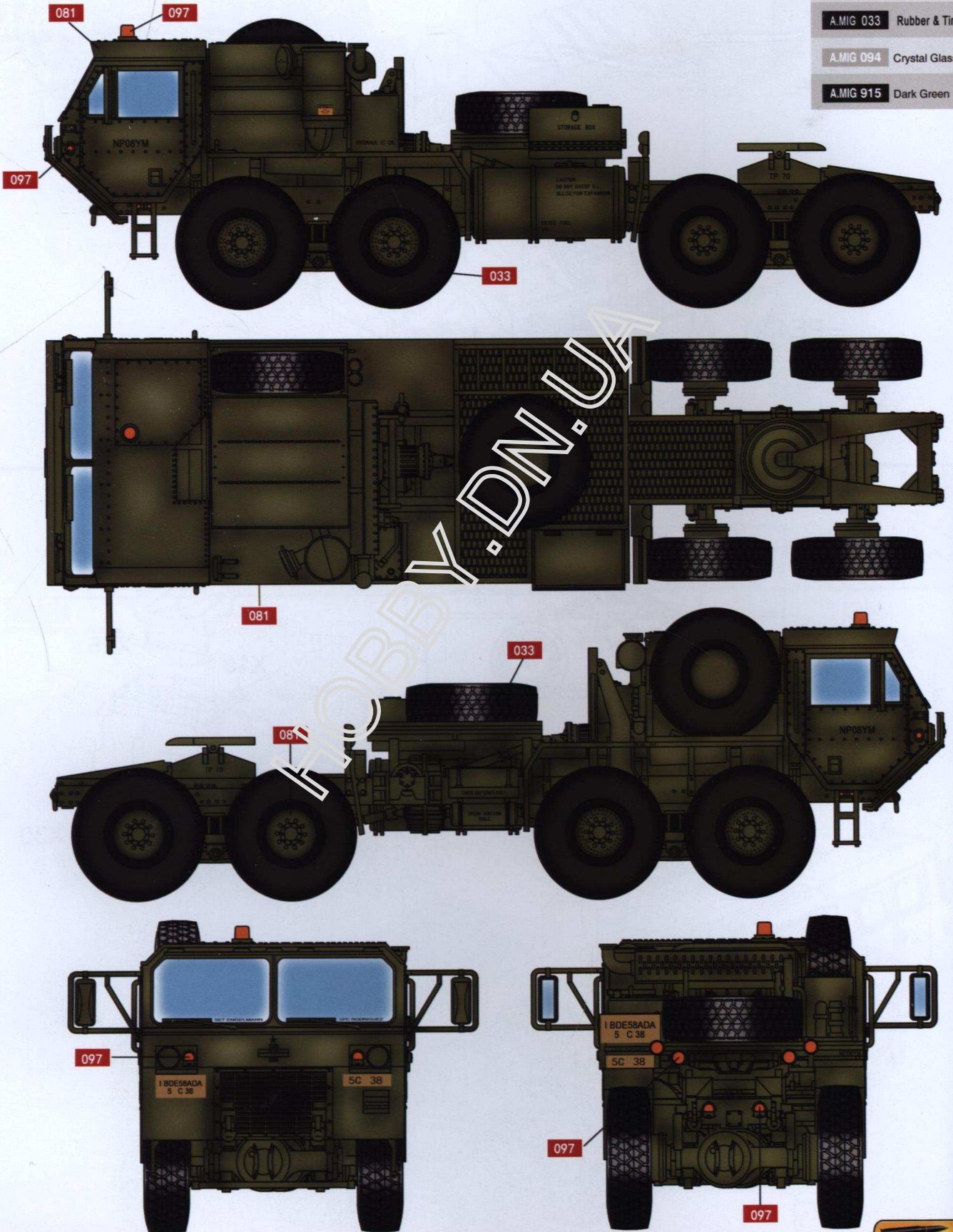

# USA M983A2 HEMTT TRACTOR

modelcollect

A.MIG 097 Crystal Orange

A.MIG 025 Moder Vehicles

A.MIG 033 Rubber & Tires

A.MIG 094 Crystal Glass

A.MIG 915 Dark Green

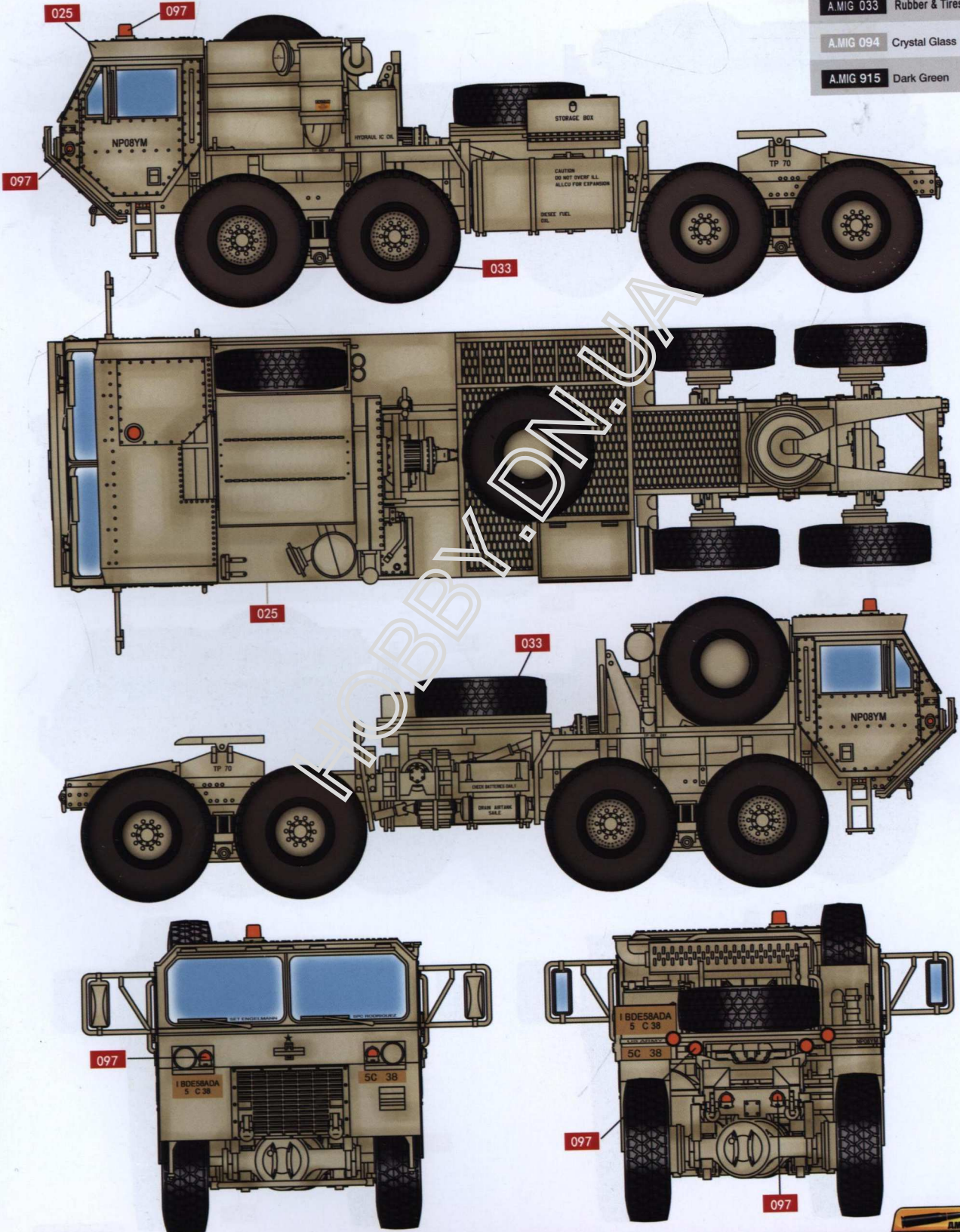

Color info and profiles by



# USA M983A2 HEMTT TRACTOR

modelcollect

A.MIG 097 Crystal Orange

A.MIG 084 Nato Green

A.MIG 033 Rubber & Tires

A.MIG 085 NATO Brown

A.MIG 046 Matt Black

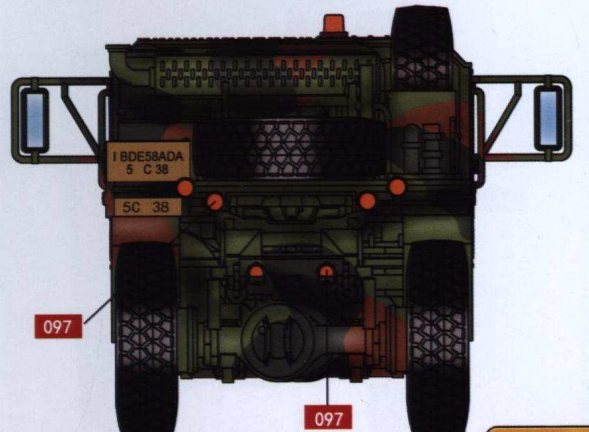
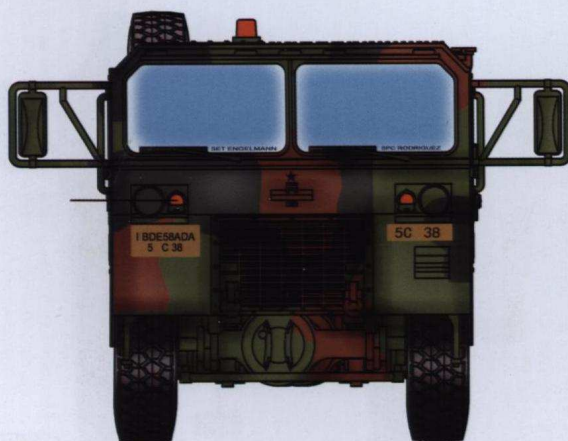
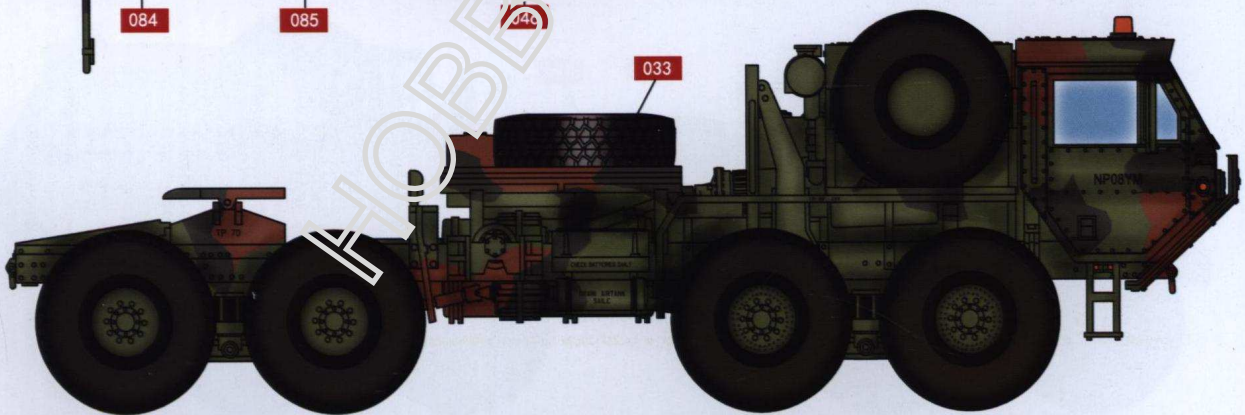
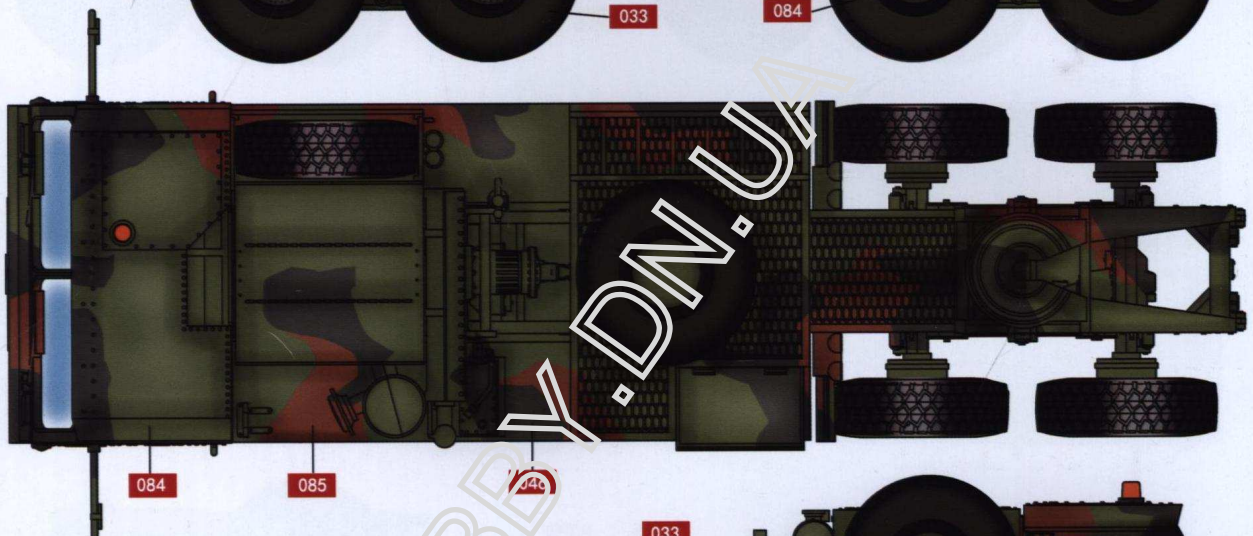
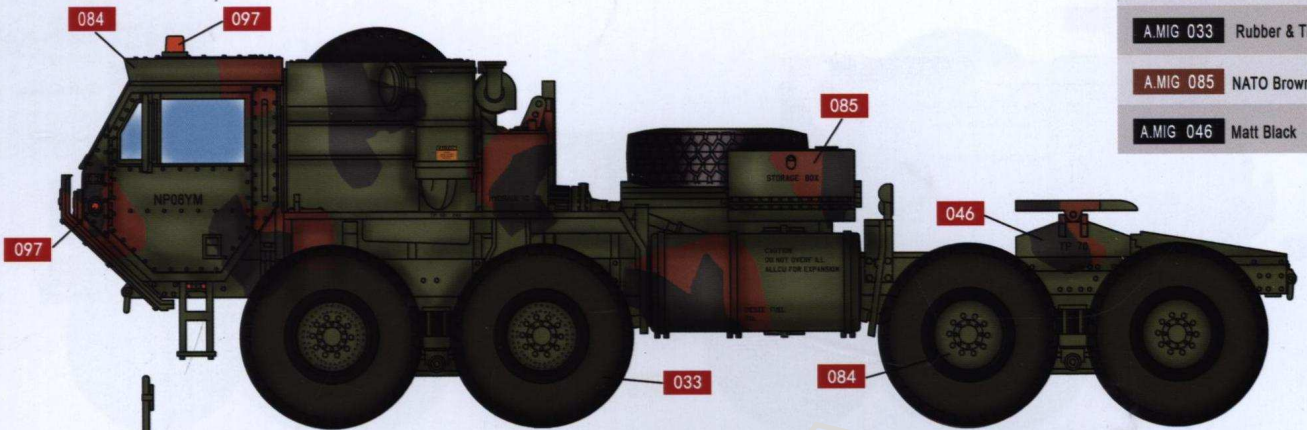

MODELCOLLECT

Color info and profiles by



# SOVIET MAZ 7410 TRACTOR COMBO

modelcollect

A.MIG 033 Rubber & Tires

A.MIG 097 Crystal Orange

A.MIG 083 ZASHCHITNIY ZELENO

A.MIG 057 Yellow Grey

A.MIG 047 Satin White

A.MIG 0191 Steel

A.MIG 187 JET EXHAUST BURNT IRON

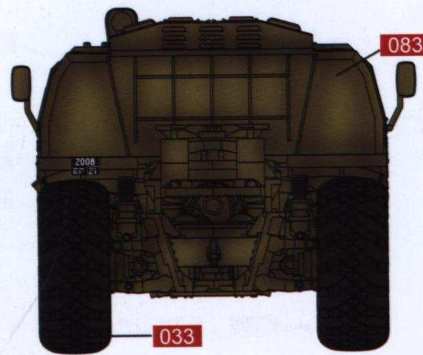
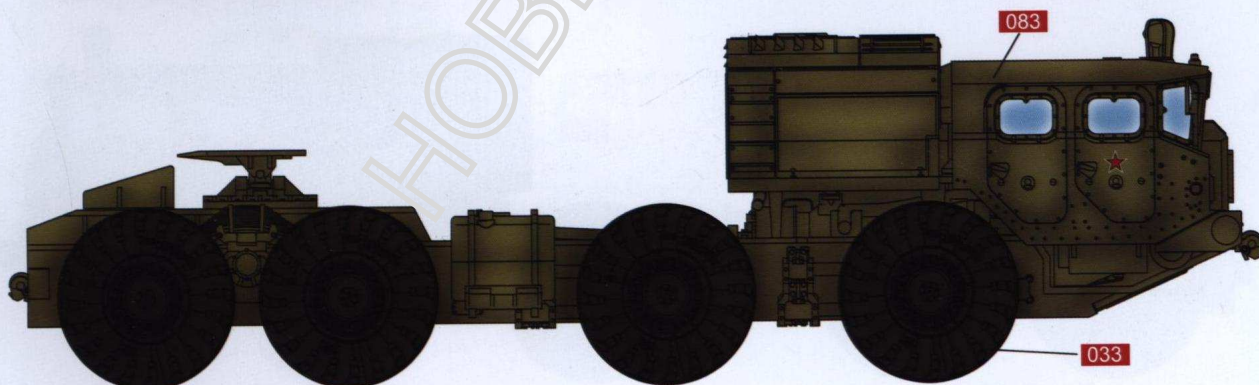
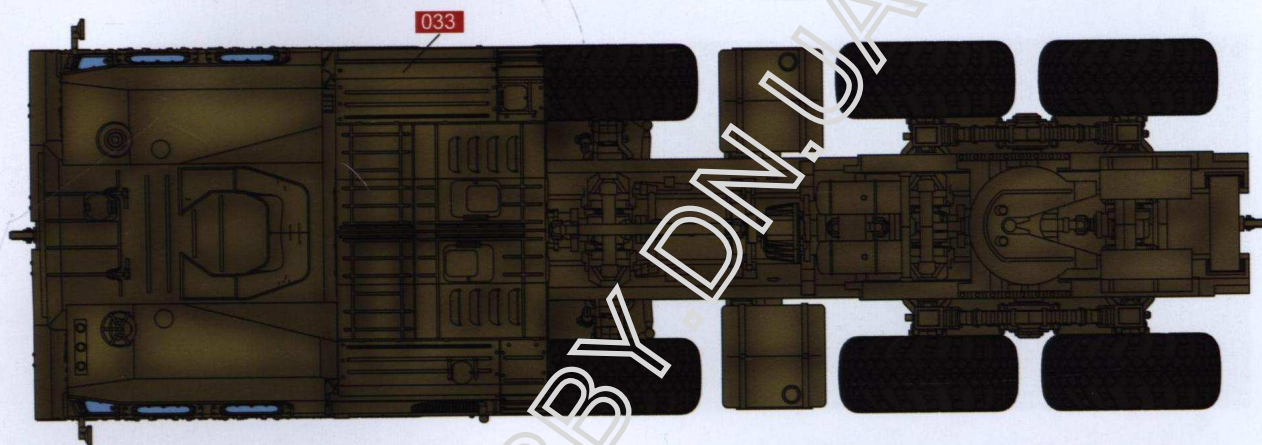
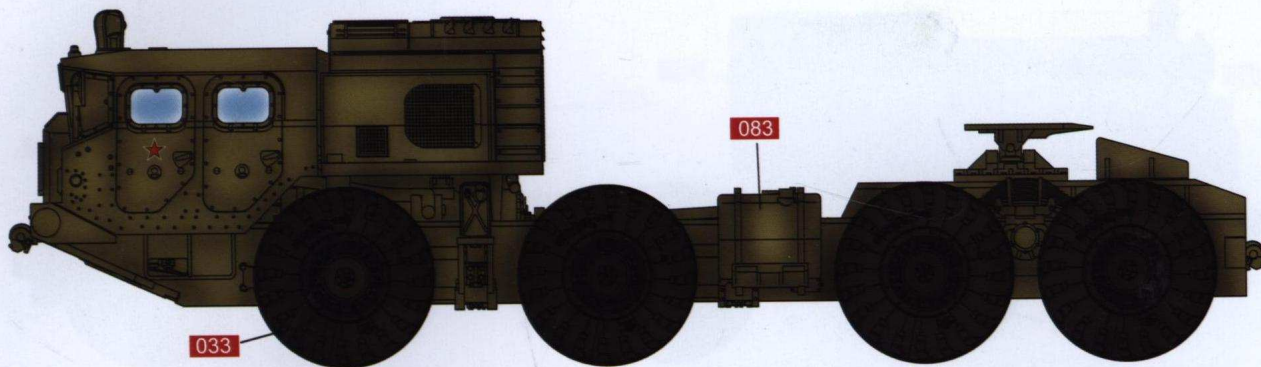

MODELCOLLECT

Color info and profiles by



# SOVIET MAZ 7410 TRACTOR COMBO

modelcollect

- A.MIG 033 Rubber & Tires
- A.MIG 097 Crystal Orange
- A.MIG 056 Green Khaki
- A.MIG 057 Yellow Grey
- A.MIG 047 Satin White
- A.MIG 0191 Steel
- A.MIG 187 JET EXHAUST BURNT IRON
- A.MIG 046 Matt Black

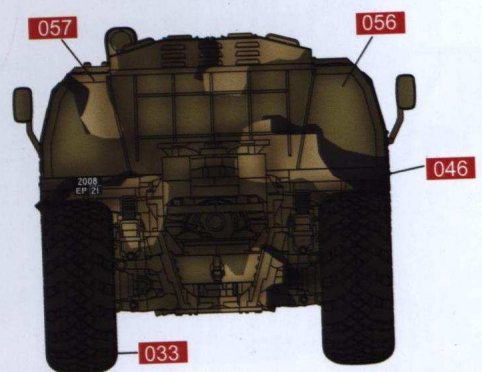
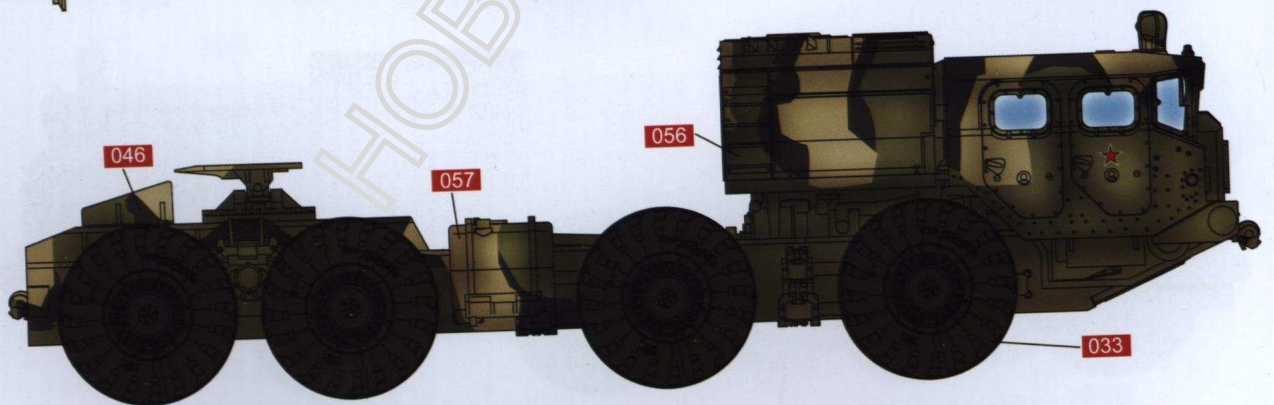
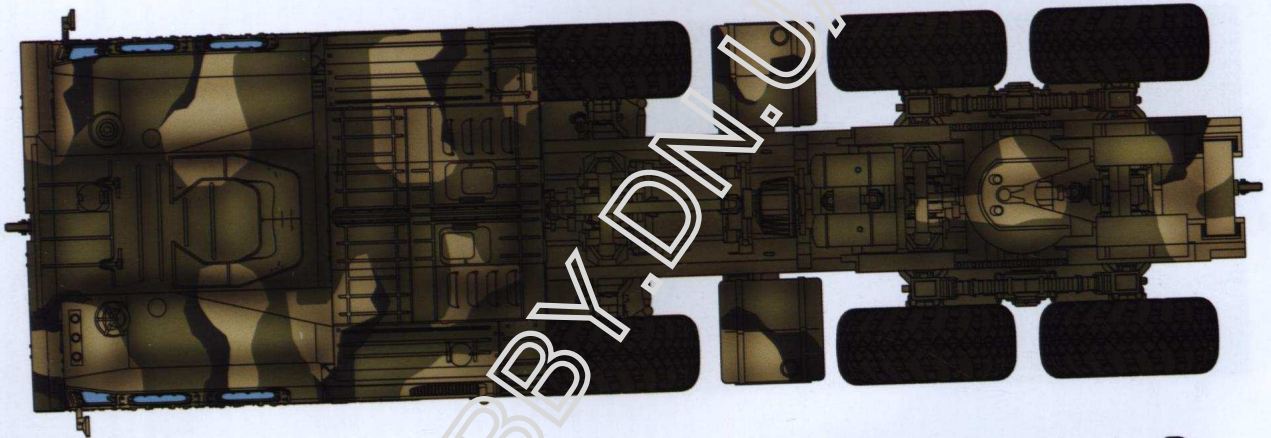
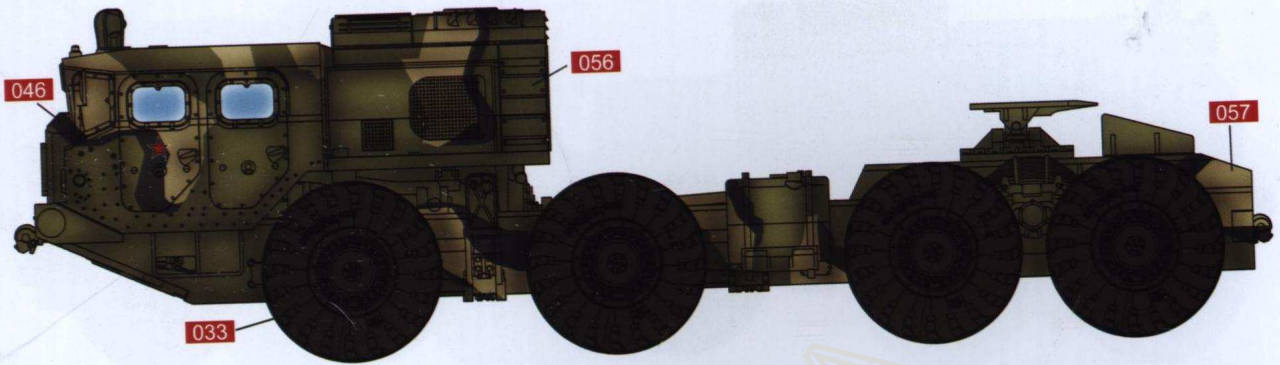

Color info and profiles by



# SOVIET MAZ 7410 TRACTOR COMBO



- A.MIG 033 Rubber & Tires
- A.MIG 097 Crystal Orange
- A.MIG 083 Zashchitniy Zeleno
- A.MIG 057 Yellow Grey
- A.MIG 059 Grey
- A.MIG 0191 Steel
- A.MIG 187 JET EXHAUST BURNT IRON
- A.MIG 046 Matt Black

