

1/35 SCALE

ITEM NO.:01593



# Russian BTR-70 APC in Afghanistan

俄罗斯BTR-70 装甲输送车(阿富汗)

## READ BEFORE ASSEMBLY:

- Study and understand these instructions thoroughly before beginning assembly
- When needed, remove photo-etch parts carefully using a modeling knife or photo etch sprue cutter, being careful not to damage or lose small parts.
- Take extra care in handling photo etch parts in order to avoid injury
- Apply instant cement sparingly to photo etch parts where instructed
- Tools recommended(not included in kit):Plastic and instant cements, sprue cutters,long nose pliers,modeling knife, small files, tweezers, pin vise & scissors. Soft cloth and sandpaper will also assist in construction.
- Glue and paint are not included in the kit. Use plastic cement and hobby paints only. Color guide for purchasing paint is included in the kit.

## 装配之前仔细阅读

- 小心用模型锉刀锉平所有零件表面的注射浇口。
- 小心用刀片切下蚀刻片零件，不要遗失小零件。
- 用力快干胶水粘合蚀刻片零件和金属轴。过量快干胶水使用可能导致可动零件会粘住，小心涂胶。
- 取蚀刻片时应特别注意安全，防止利边划伤手指。
- 某些零件表面需贴上水贴纸，请选择在装配的同时进行。
- 推荐模型工具(自备)：胶水，水口剪刀，长咀钳，刀片，锉刀，镊子，钳，钻，剪刀，瞬间快干胶。
- 软布同砂纸同时也应该是必备工具。
- 请使用塑料胶水和油漆，模型内不含。



配重  
Weight



使用强力胶  
Cyanacrylate glue



钻孔  
Make hole



切除  
Cut / Remove



贴纸  
Decal



锉平  
File / Sand



选择  
Option



不涂胶水  
No cement



弯曲  
Bend

## 水贴纸的使用:

- 1.从水贴纸上剪下印花;
- 2.将印花放入温水中浸10秒,然后放在干净布上。
- 3.拿着印花纸板将印花移到模型上;
- 4.手指蘸水将印花移到适当的位置;
- 5.用软布轻压印花直至水干,气泡消失

## DECAL APPLICATION

- 1.Cut decals from sheet as needed
- 2.Dip the decal in warm water for about 10 seconds and then place on soft clean cloth.
- 3.Hold the decal backing sheet edge and gently slide the decal onto the model in its proper position.
- 4.While still wet,decal can be adjusted for better fit on model by dampening it gently with your finger.
- 5.When placed in the proper position,gently press decal down with a soft cloth until excess water and air bubbles are gone.
- 6.Allow decal to dry completely before handling model

部品图 Part

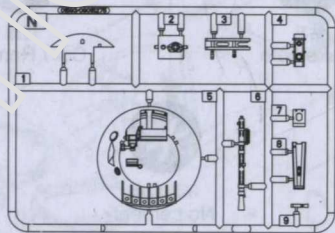
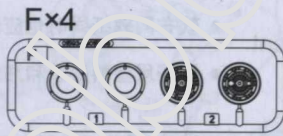
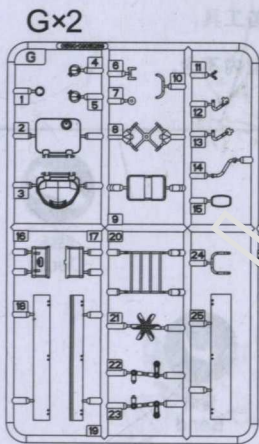
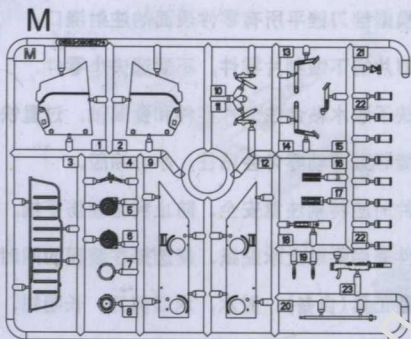
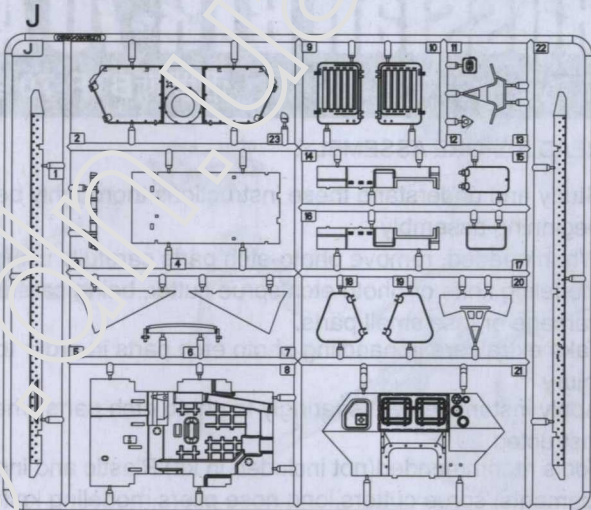
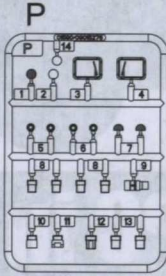
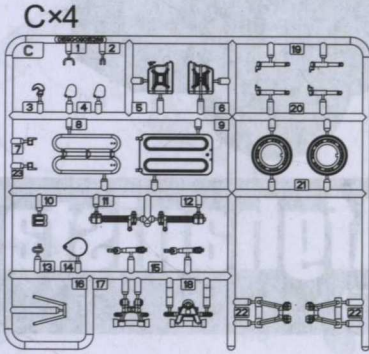
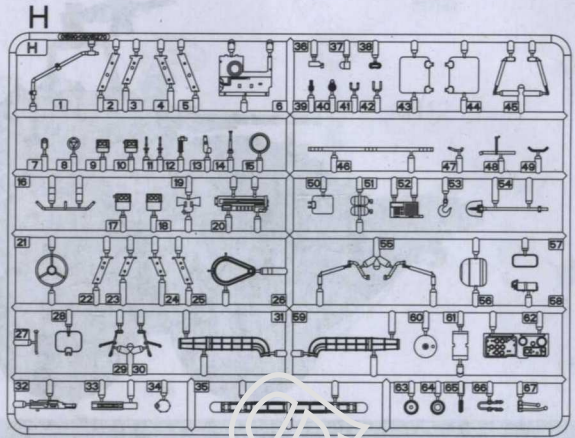
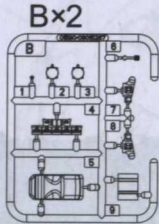
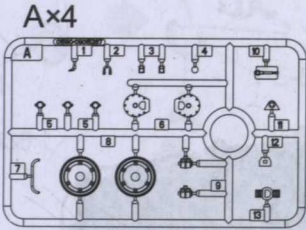

《车面》  
Upper hull

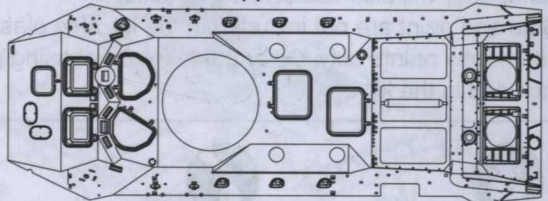

《车底》  
Lower hull

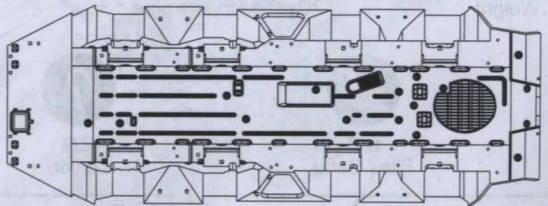

《轮胎》  
Tyre ×8



《聚乙烯套》  
Poly cap

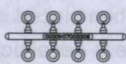

《蚀刻片-A》  
PE-A

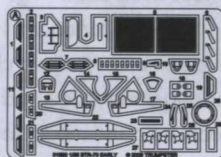

《蚀刻片-B》  
PE-B

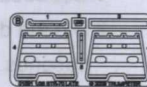

《水贴》  
Decal



1

弯曲 Bend PE-A1

弯曲 Bend PE-A11

弯曲 Bend PE-A20

弯曲 Bend PE-A11

弯曲 Bend PE-A1

《车面》 Upper hull

选择 Option

选择 Option

切除 Cut / Remove

弯曲 Bend PE-A21

选择 Option

选择 Option

切除 Cut / Remove

切除 Cut / Remove

锉平 File / Sand

切除 Cut / Remove

选择 Option

钻孔 Make hole

选择 Option

M3 收起状态, 车面开孔, 参考14页。  
M3 close, upper hull make holes, refer to the 14 page.

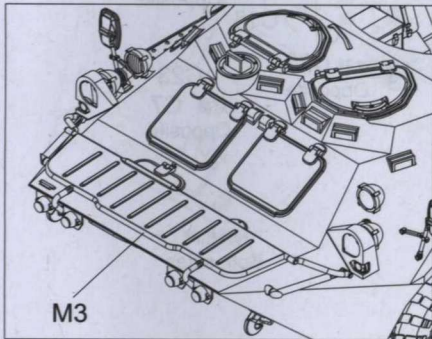

M3

切除 Cut / Remove

切除 Cut / Remove

锉平 File / Sand

《车底》 Lower hull

锉平 File / Sand

切除 Cut / Remove

切除 Cut / Remove

锉平 File / Sand

2

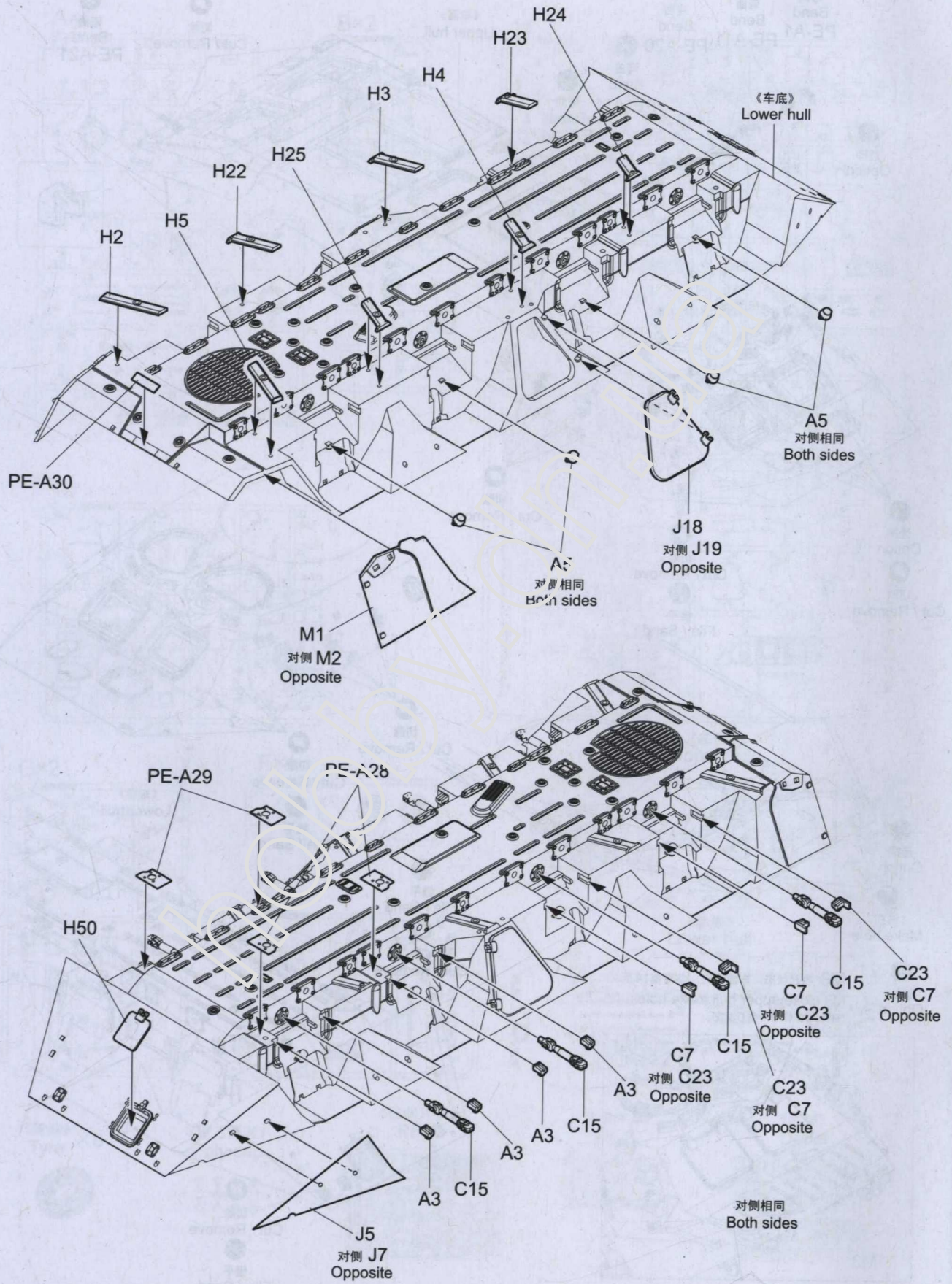

3

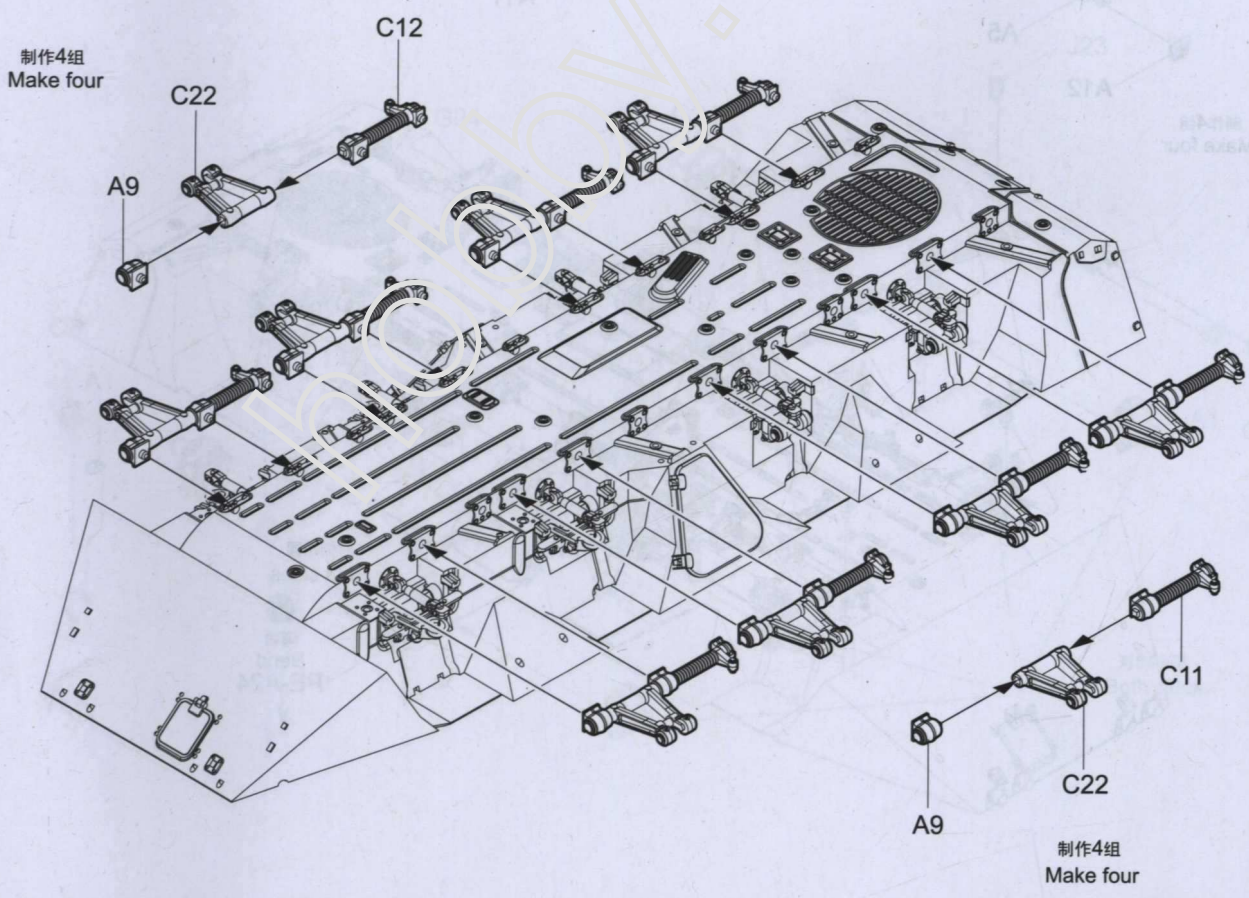
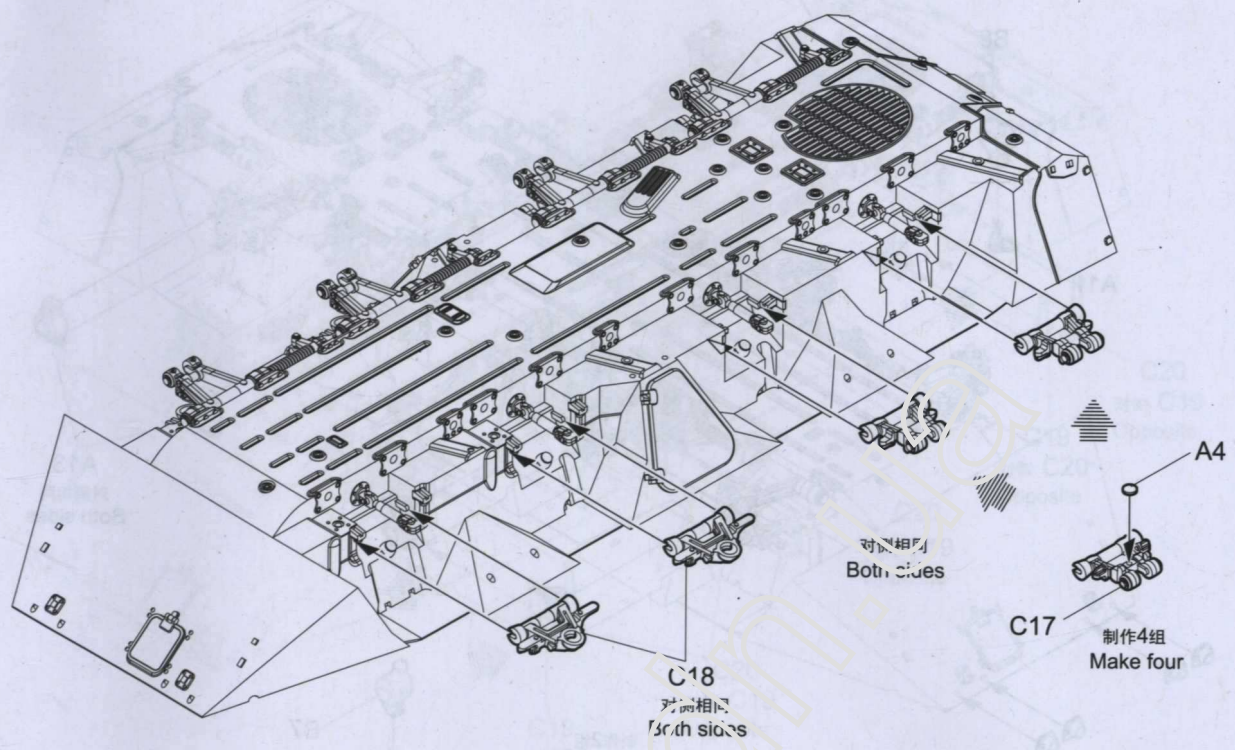

4

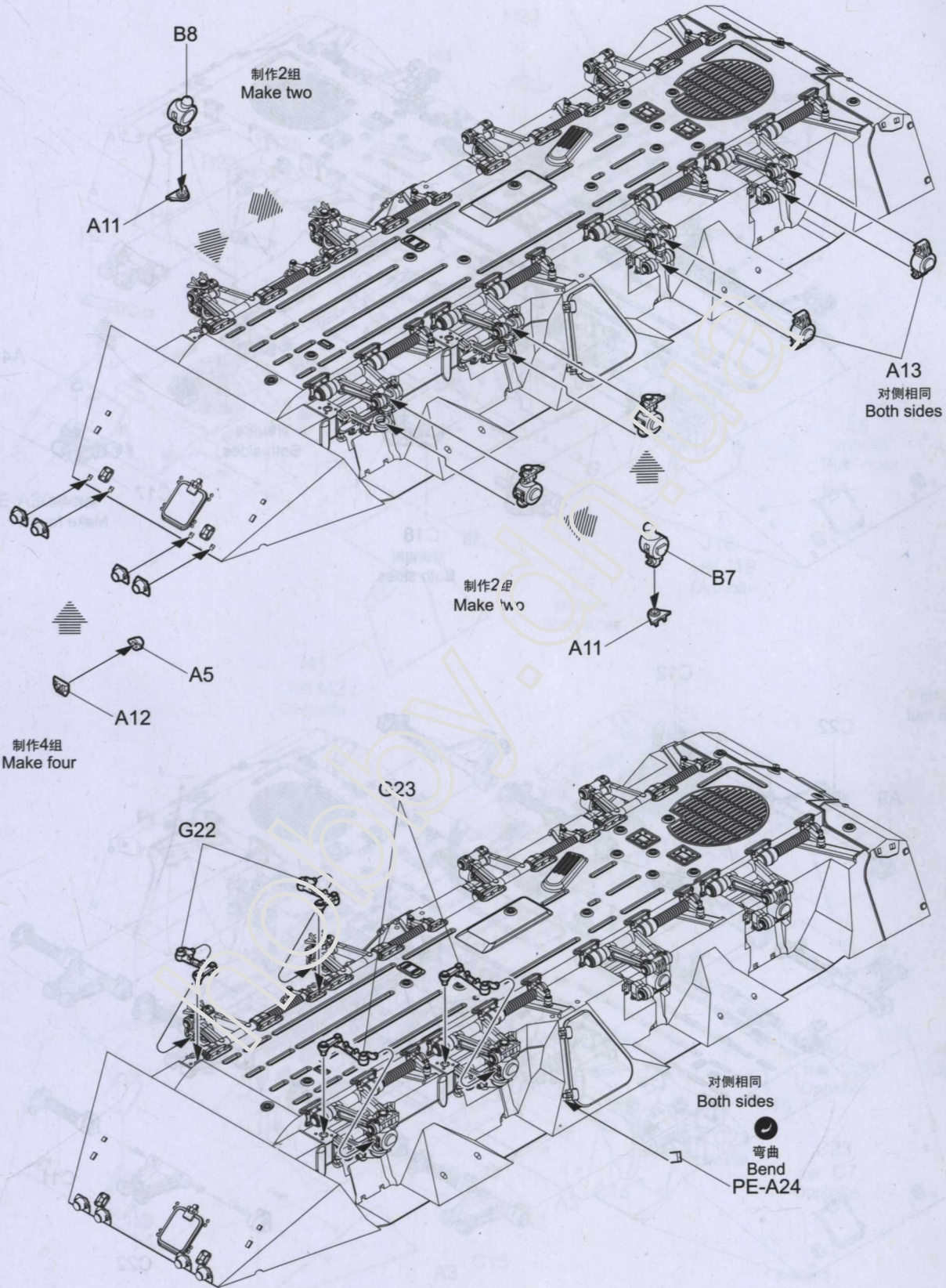

5

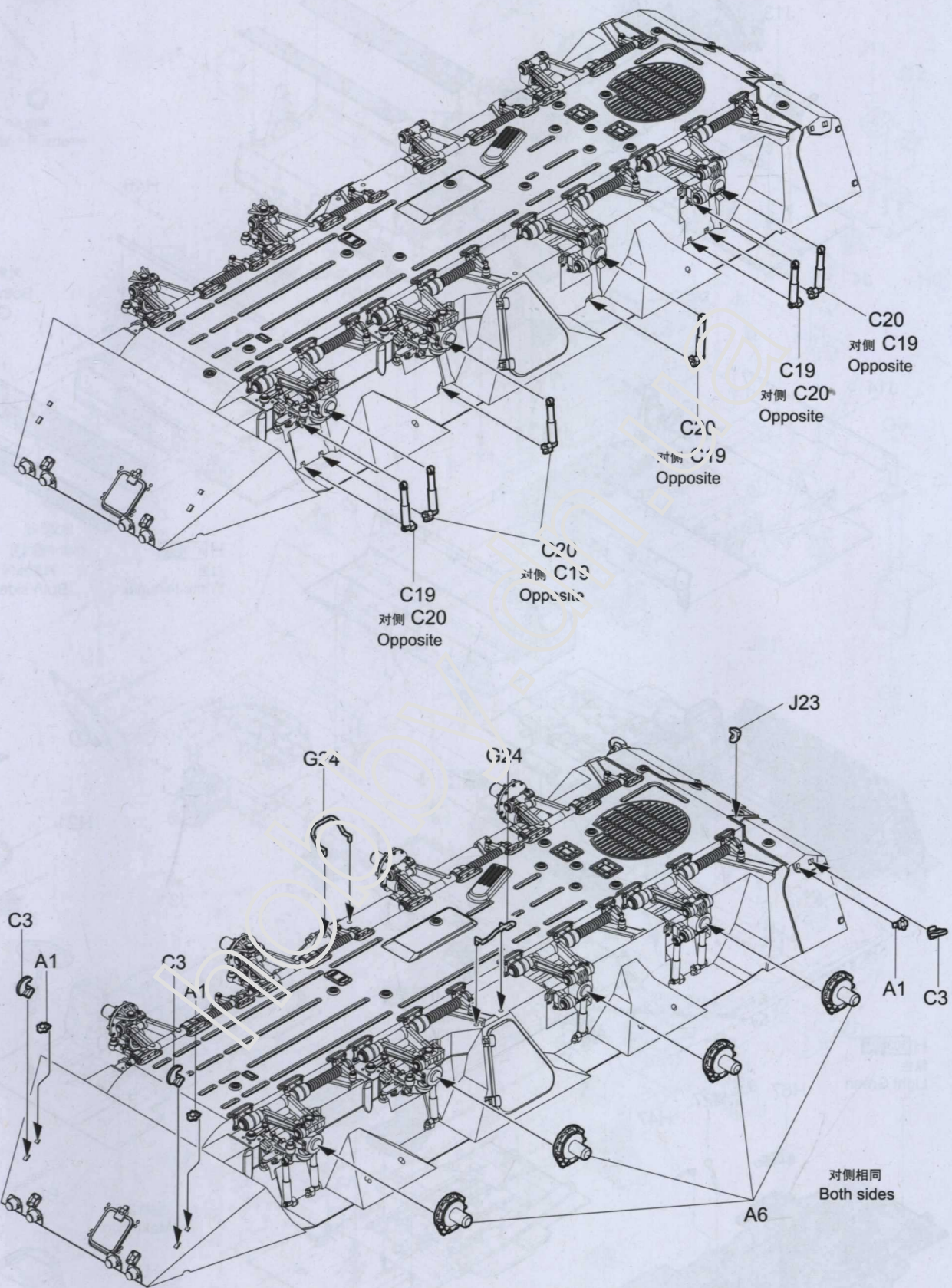

6

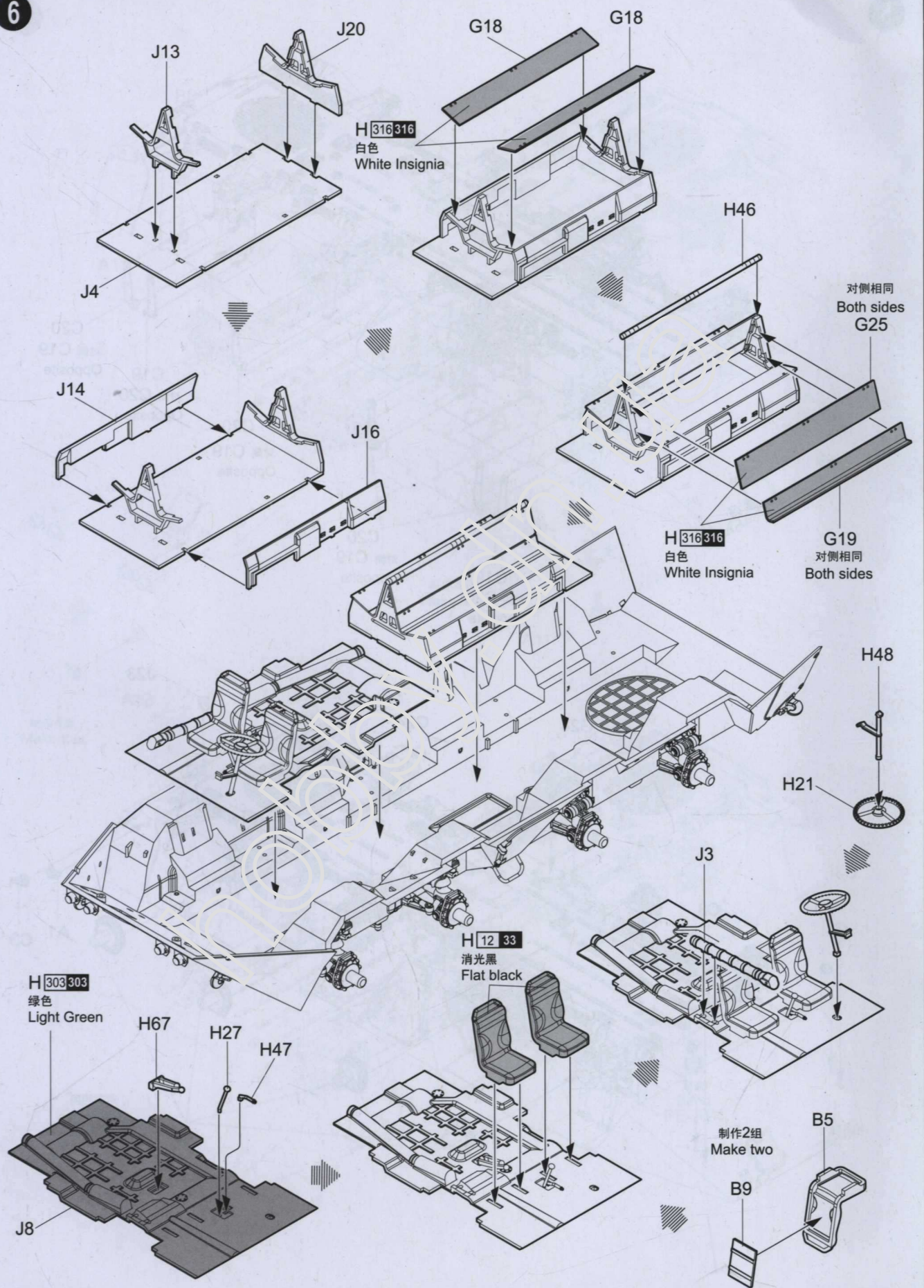



7

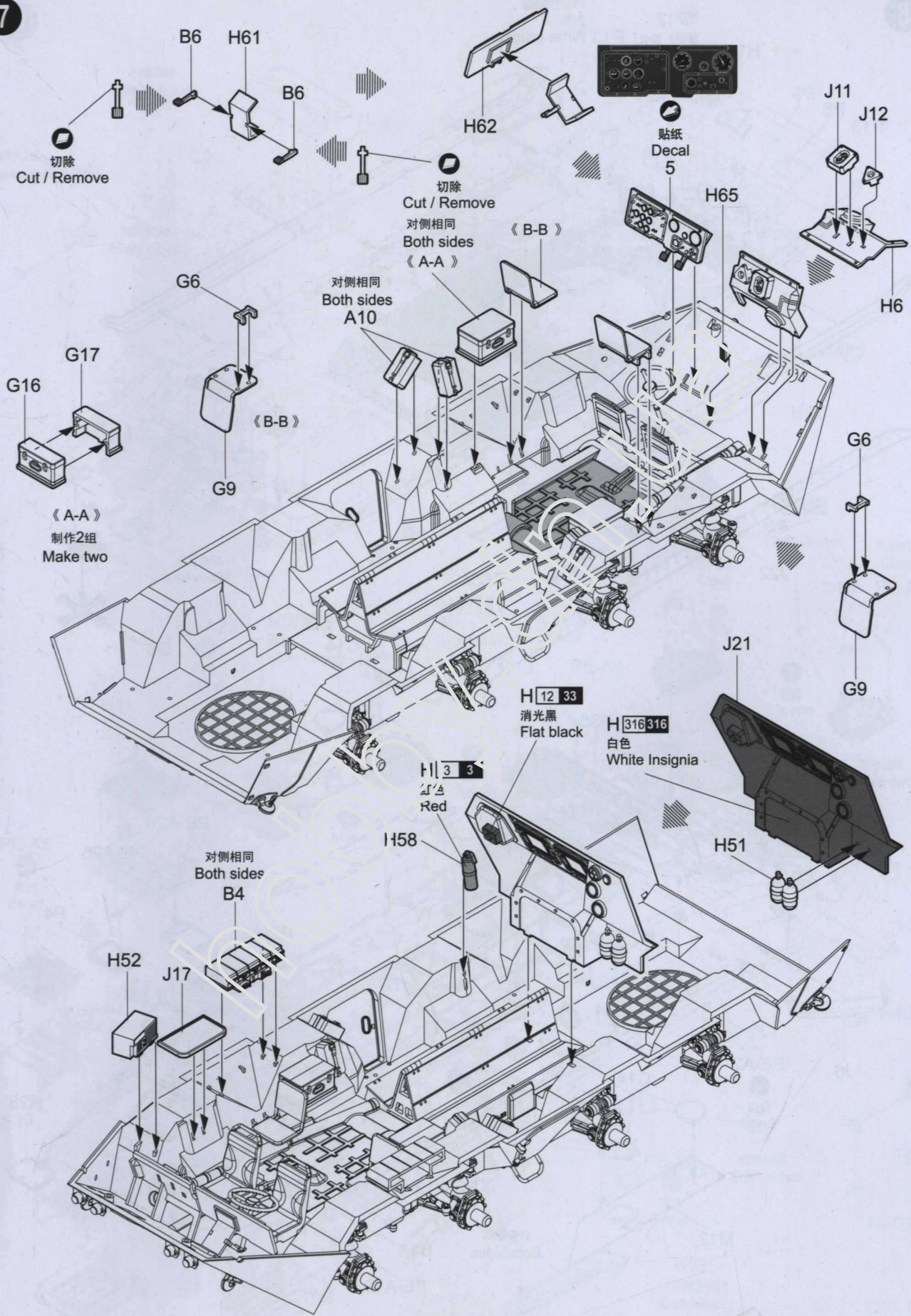

8

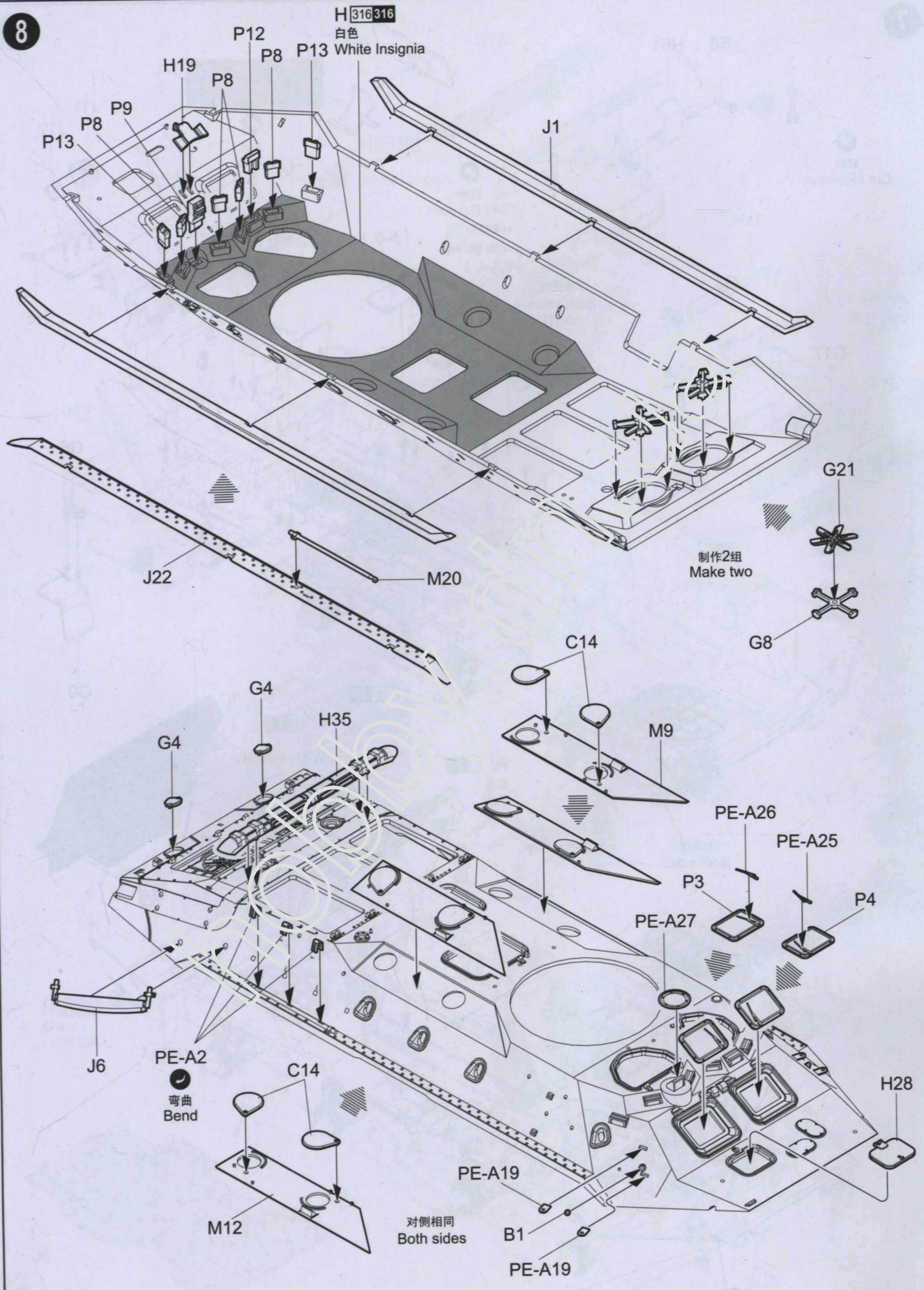

9

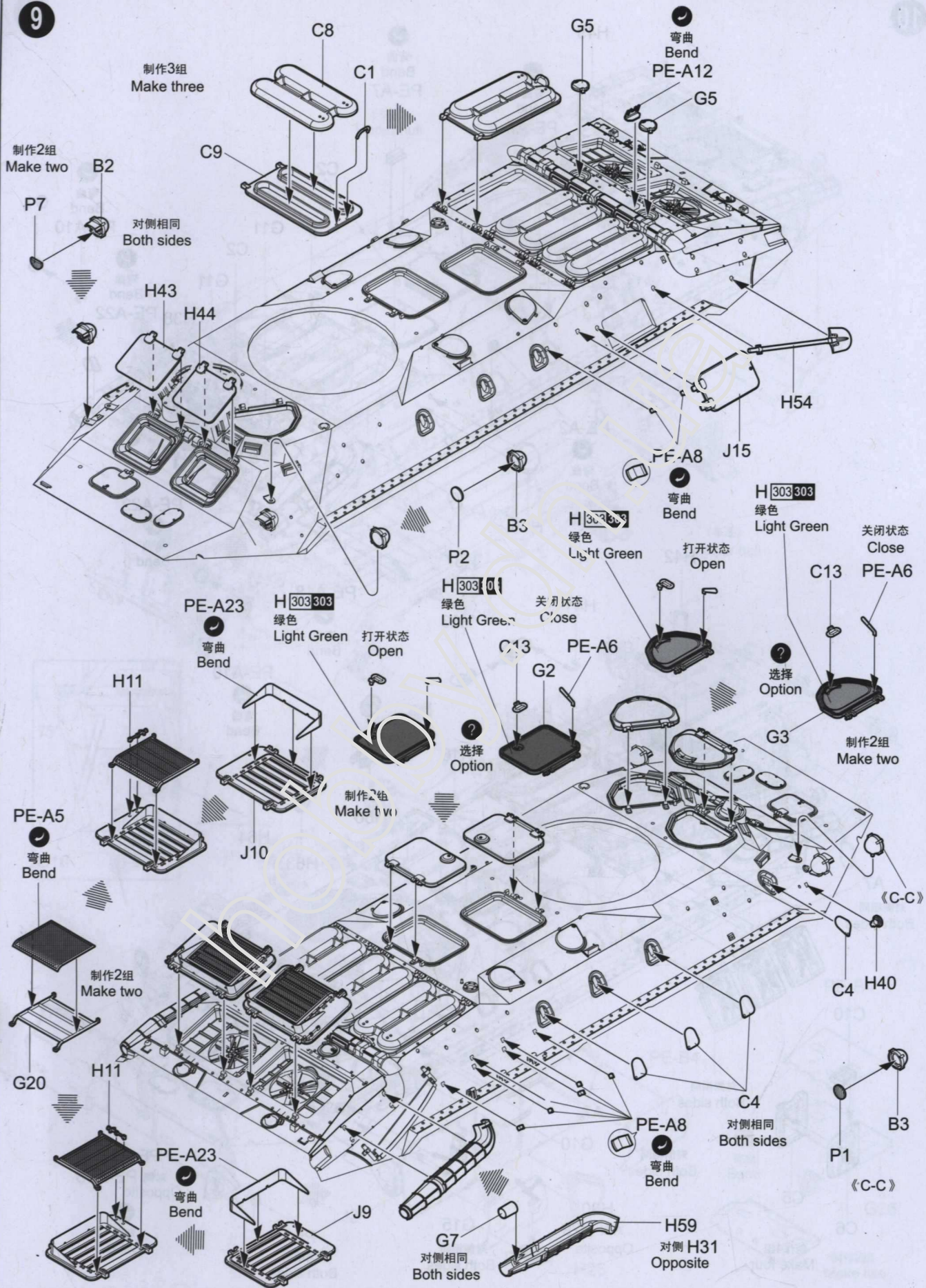

10

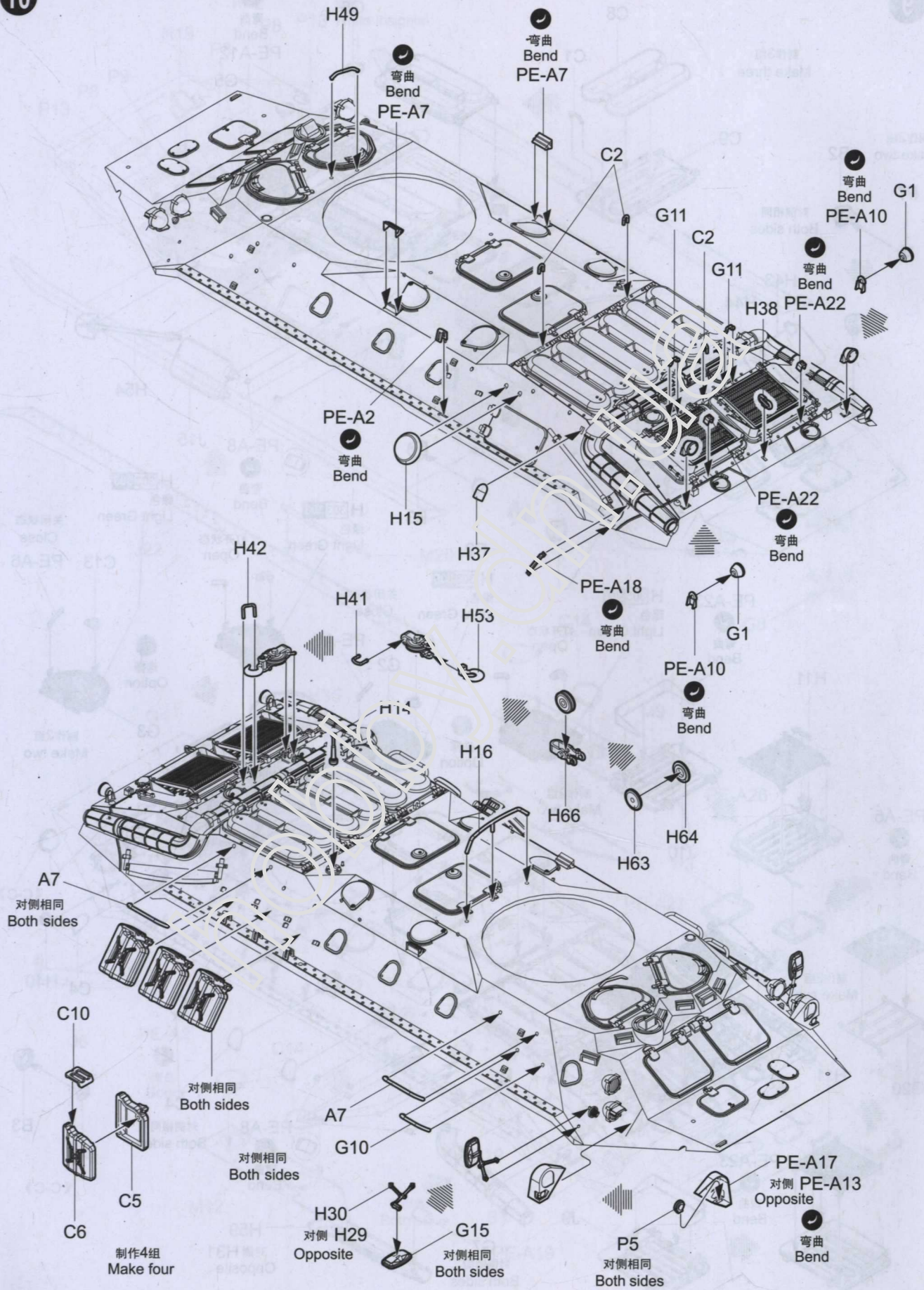

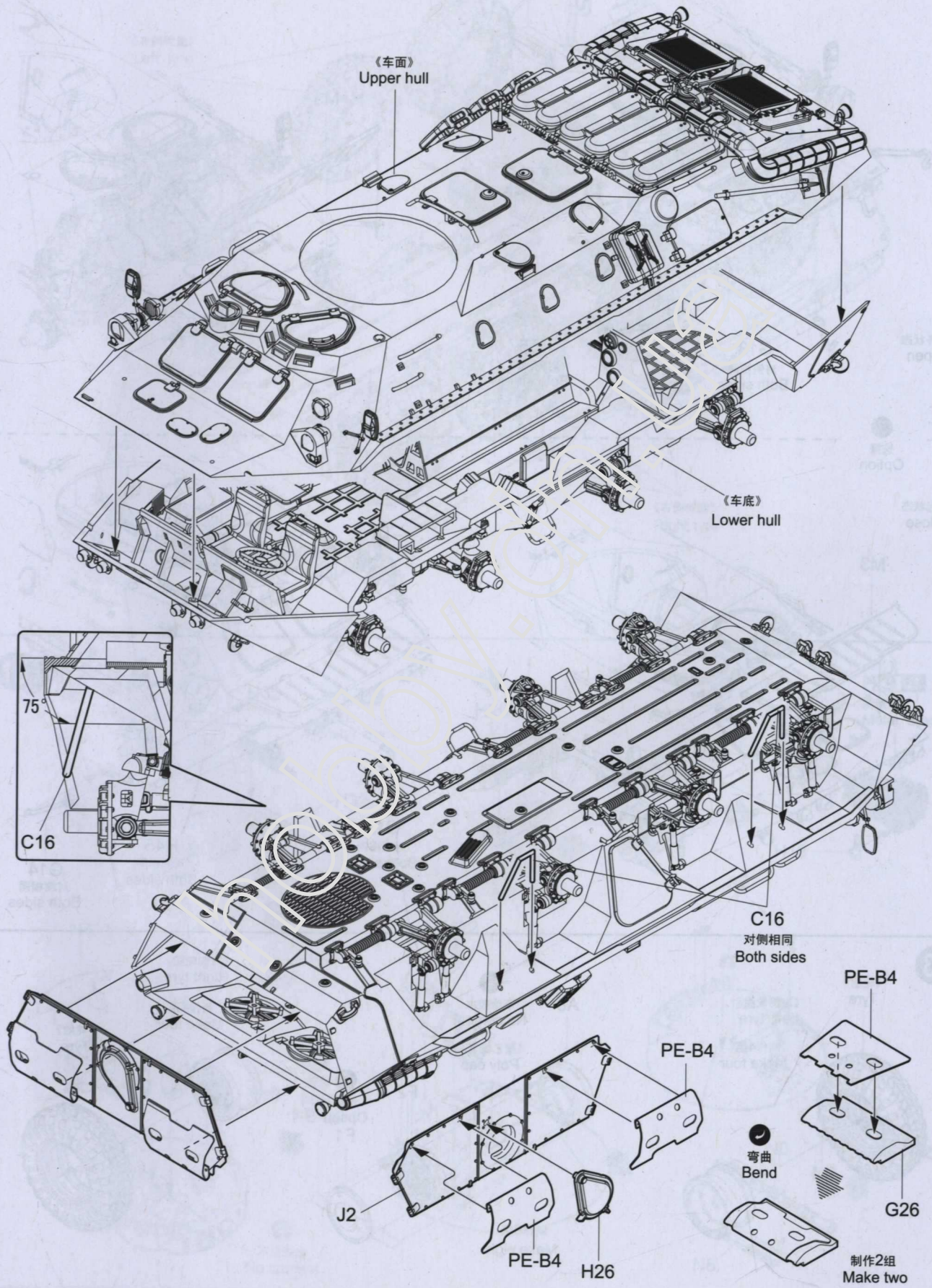

12

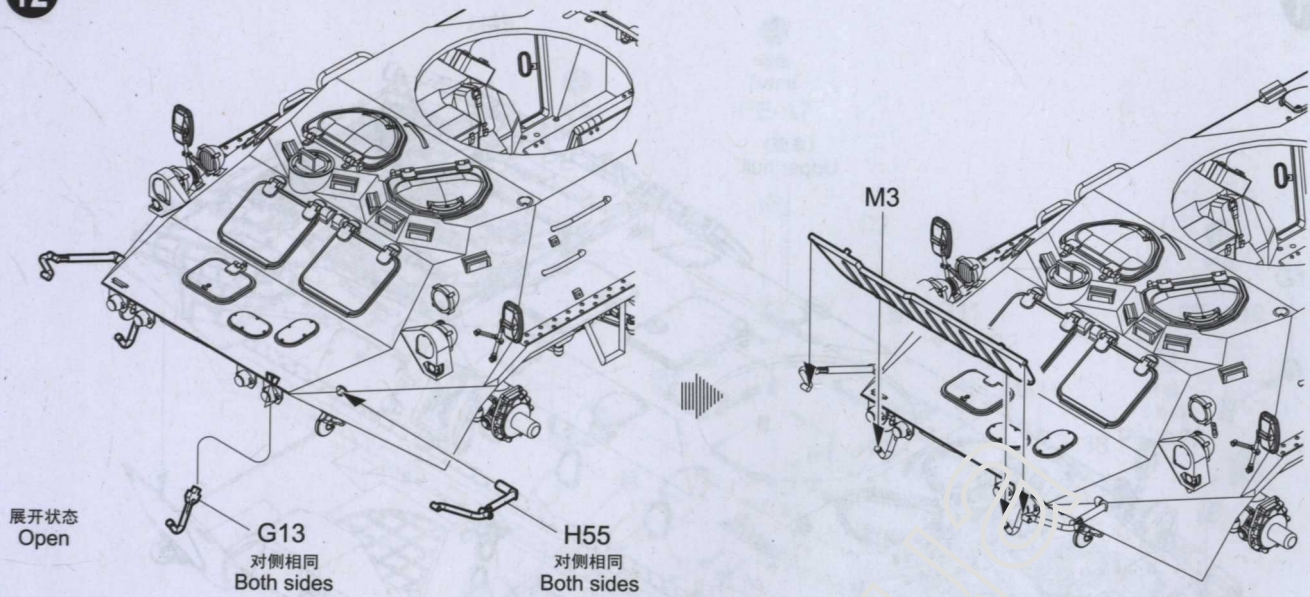

展开状态  
Open

G13  
对侧相同  
Both sides

H55  
对侧相同  
Both sides

选择  
Option

收起状态  
Close

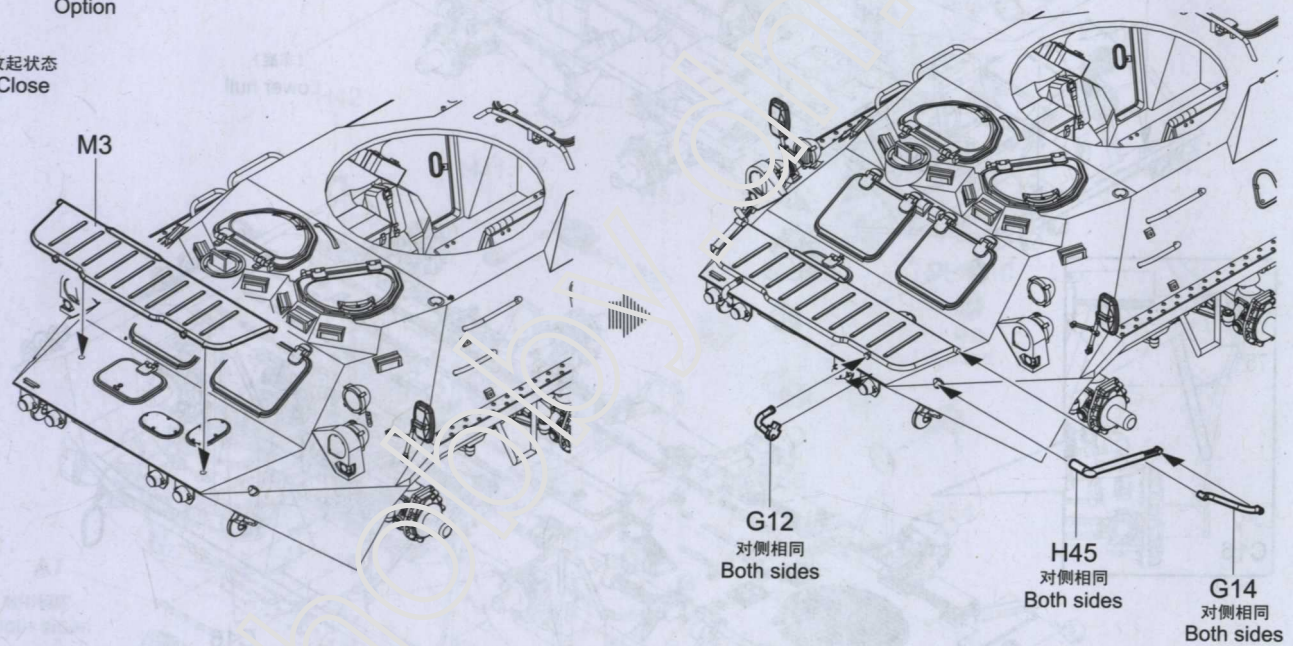

G12  
对侧相同  
Both sides

H45  
对侧相同  
Both sides

G14  
对侧相同  
Both sides

13

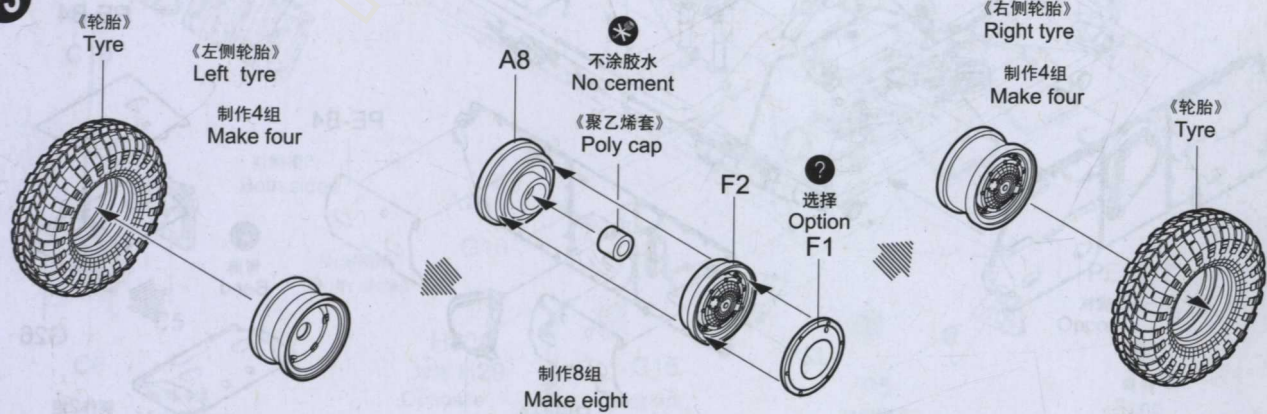

《轮胎》  
Tyre

《左侧轮胎》  
Left tyre  
制作4组  
Make four

A8  
不涂胶水  
No cement

《聚乙烯套》  
Poly cap

F2  
选择  
Option  
F1

制作8组  
Make eight

《右侧轮胎》  
Right tyre  
制作4组  
Make four

《轮胎》  
Tyre

14

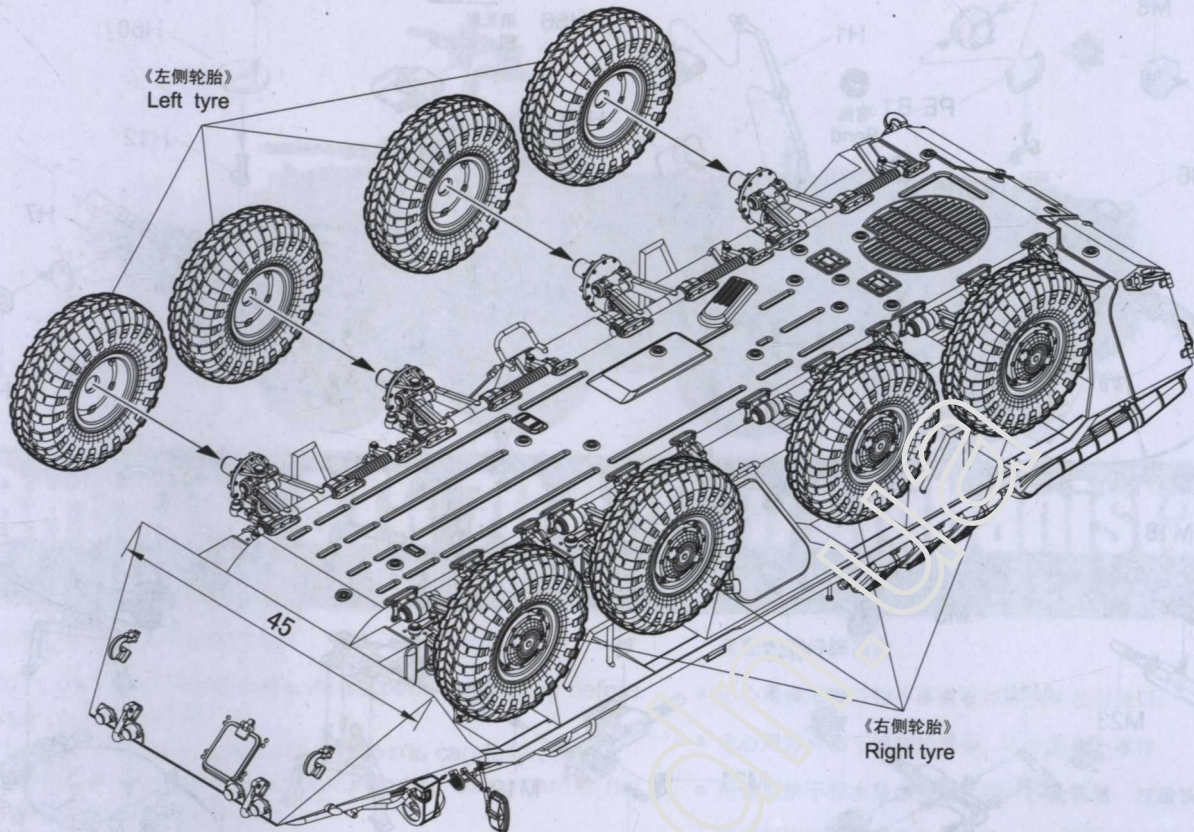

15

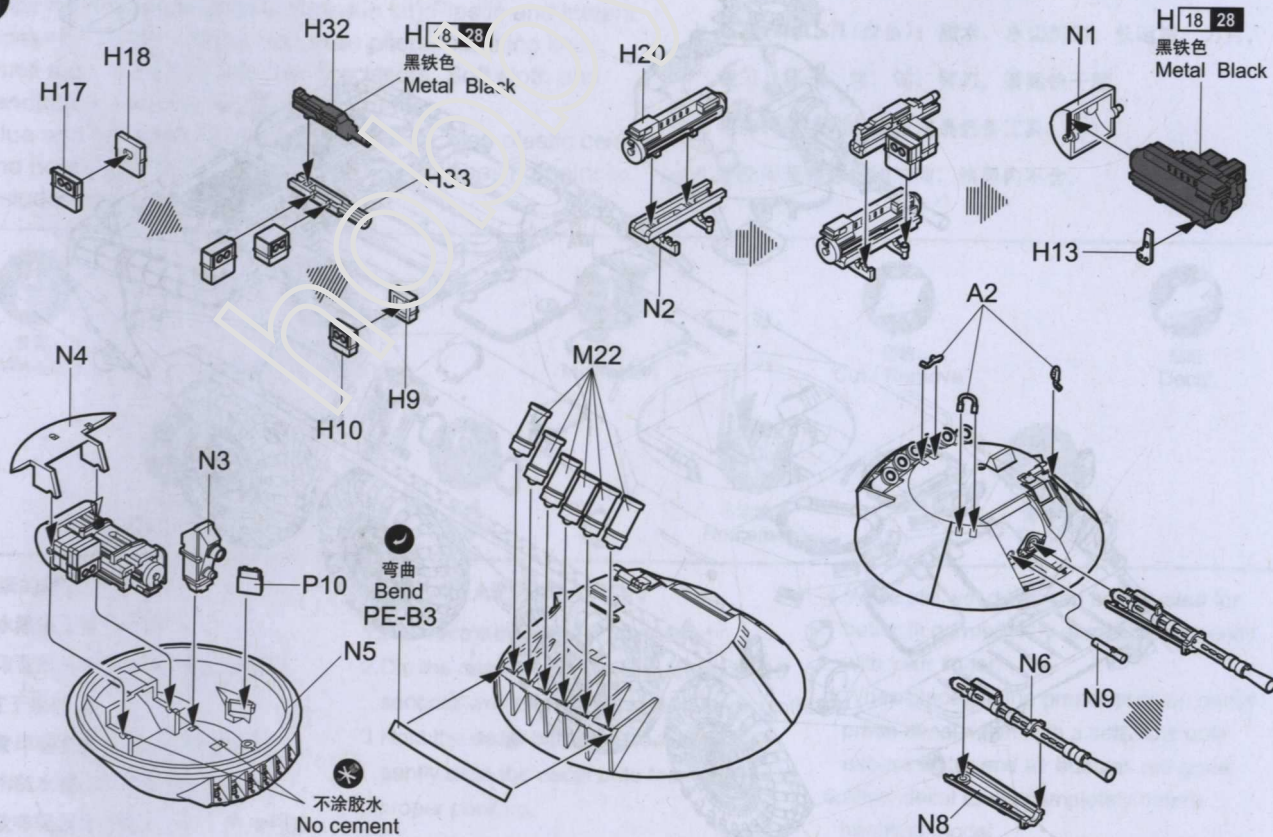

16

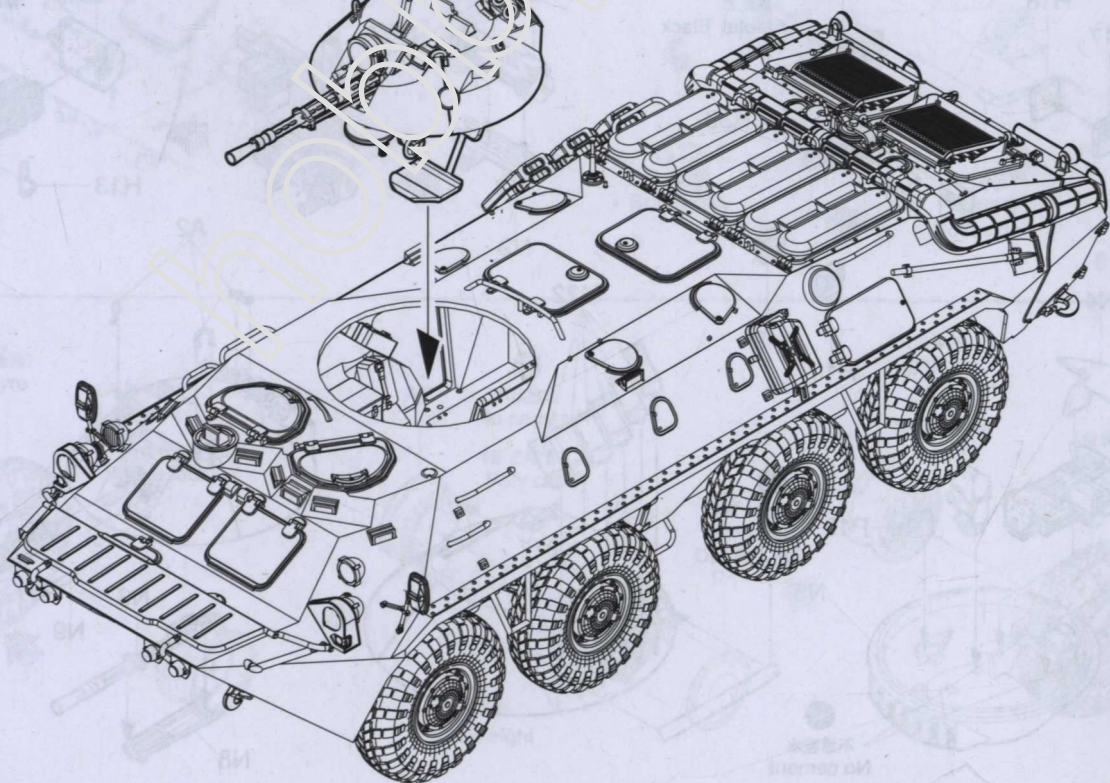
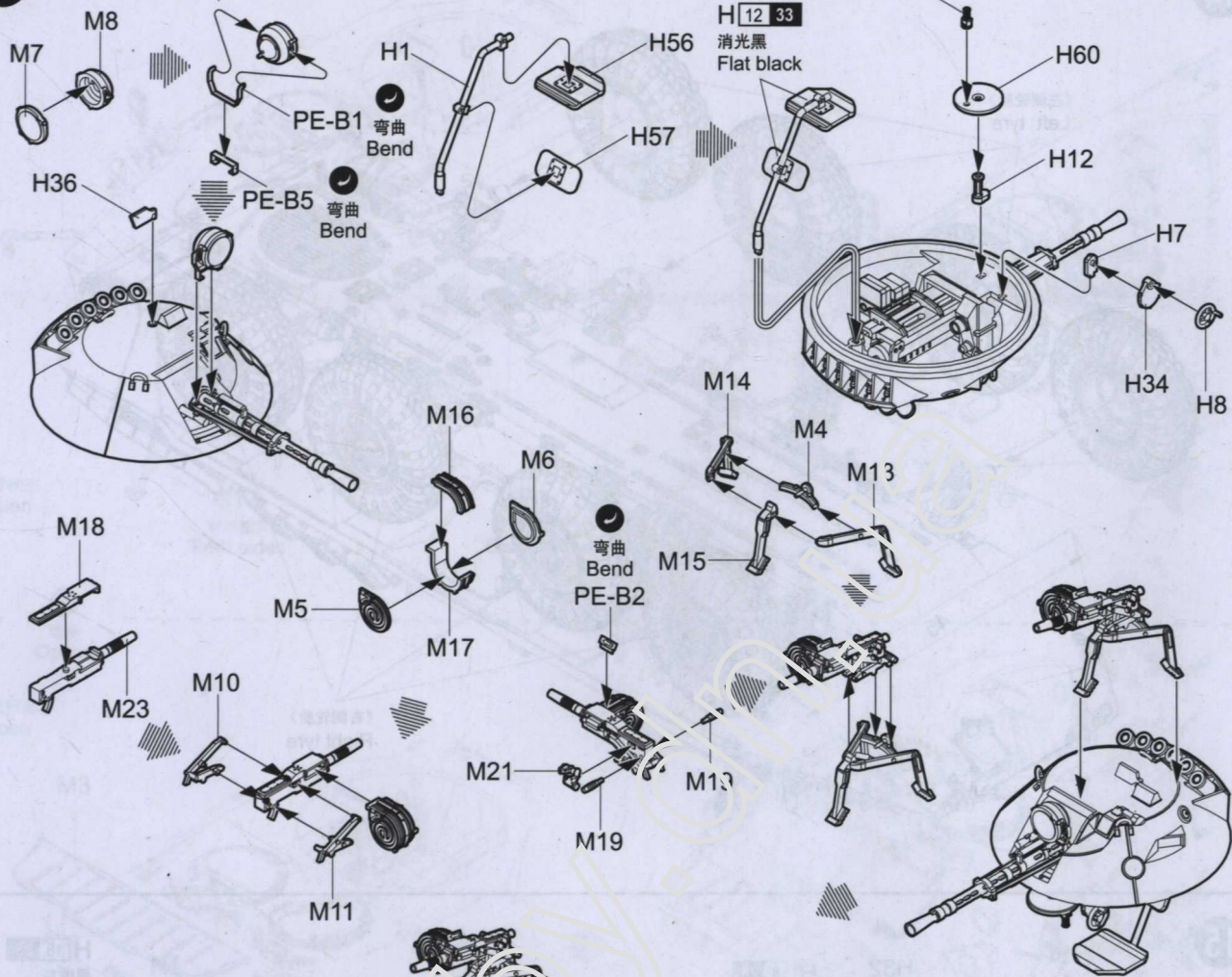



# 涂装同标贴指示 Painting & Marking guide

## PAINT REFERENCE COLOUR

Color	Mr.Hobby	Vallejo	Model Master	Tamiya	Humbrol
Metal Black 黑铁色	H 18 28	864	1402	-	-
Light Green 浅绿色	H 303 303	-	1713	XF20	117
Tire Black 胎黑色	H 77 137	-	-	-	-
Silver 银色	H 8 8	997	1546	X11	11
Wood Brown 木棕色	H 37 43	983	1701	-	186
Sandy Brown 砂黄色	H 79 39	824	-	XF59	93
Clear Red 透明红	H 90 47	934	-	XF27	-

**A**

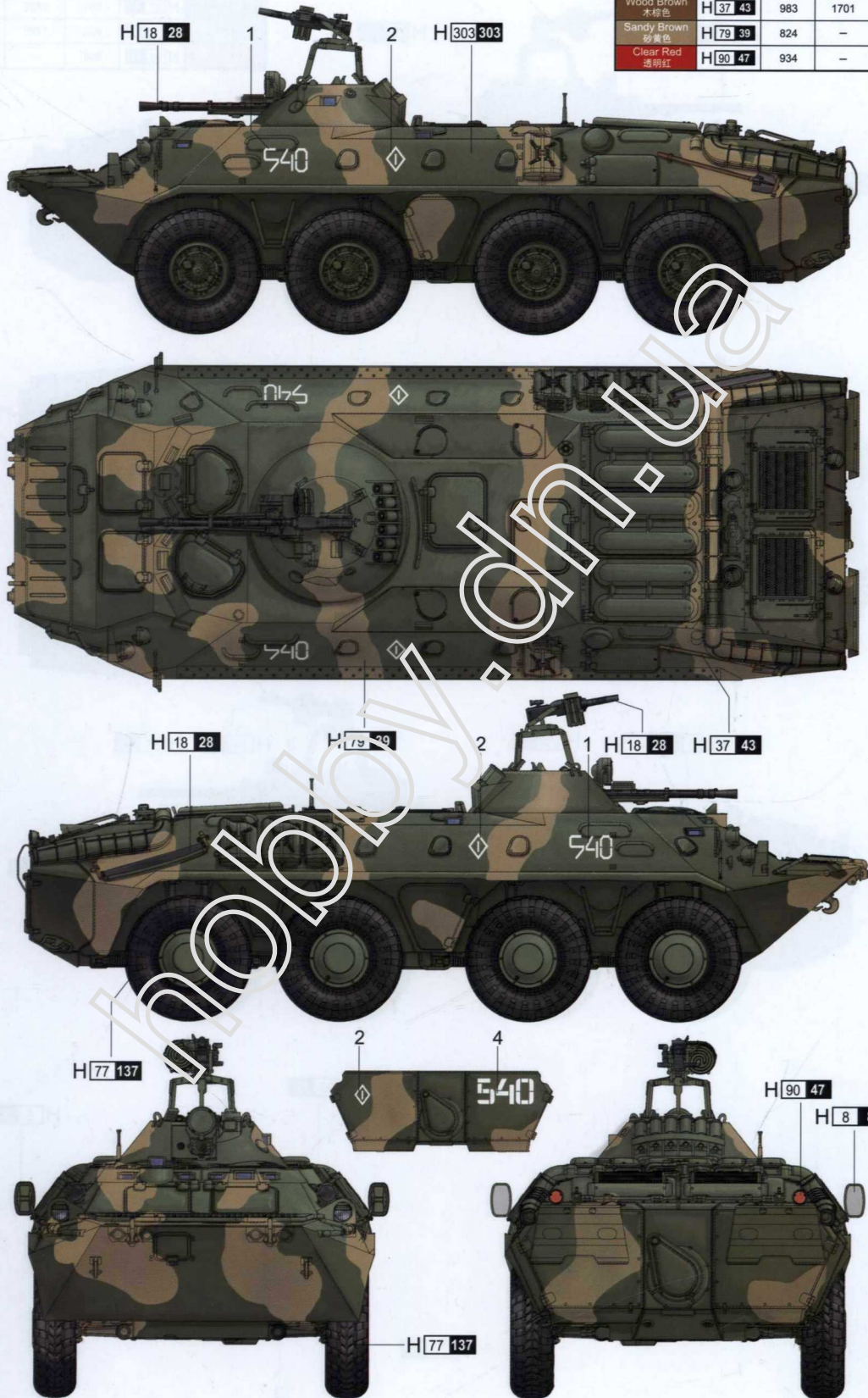

H AQUEOUS HOBBY COLOR ■ Mr. COLOR

# 涂装同标贴指示 Painting & Marking guide

## PAINT REFERENCE COLOUR

Color	Mr.Hobby	Vallejo	Model Master	Tamiya	Humbrol
Metal Black 黑铁色	H 18 28	864	1402	-	-
Light Green 浅绿色	H 303 303	-	1713	XF20	117
Tire Black 胎黑色	H 77 137	-	-	-	-
Silver 银色	H 8 8	997	1546	X11	11
Wood Brown 木棕色	H 37 43	983	1701	-	186
Medium Grey 灰色	H 306 306	870	1725	XF20	-
Clear Red 透明红	H 90 47	934	-	XF27	-

**B**

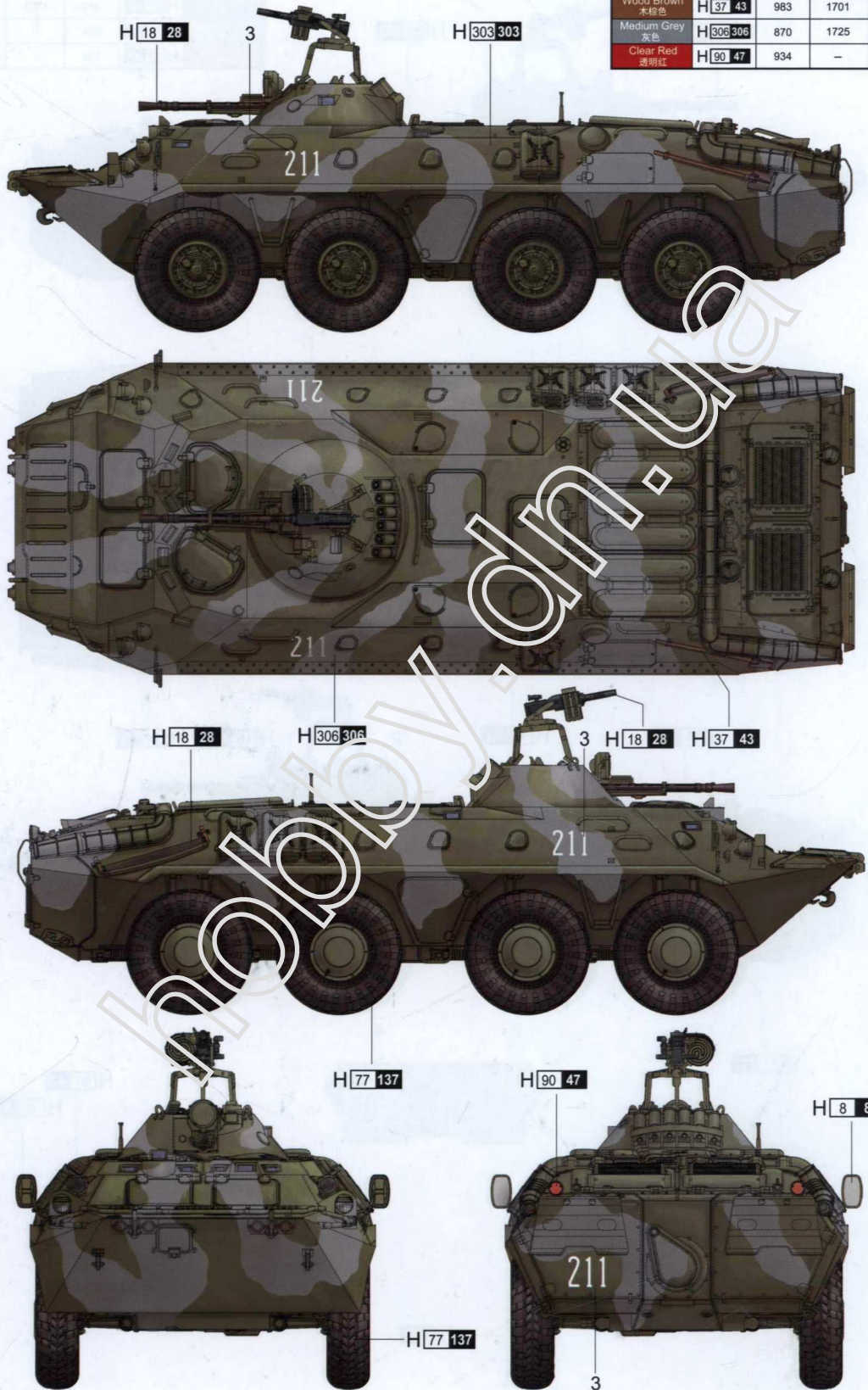

☒ AQUEOUS HOBBY COLOR    ■ Mr. COLOR