

SCALE  
1/144  
USAF B-47  
"306th BW(M)"

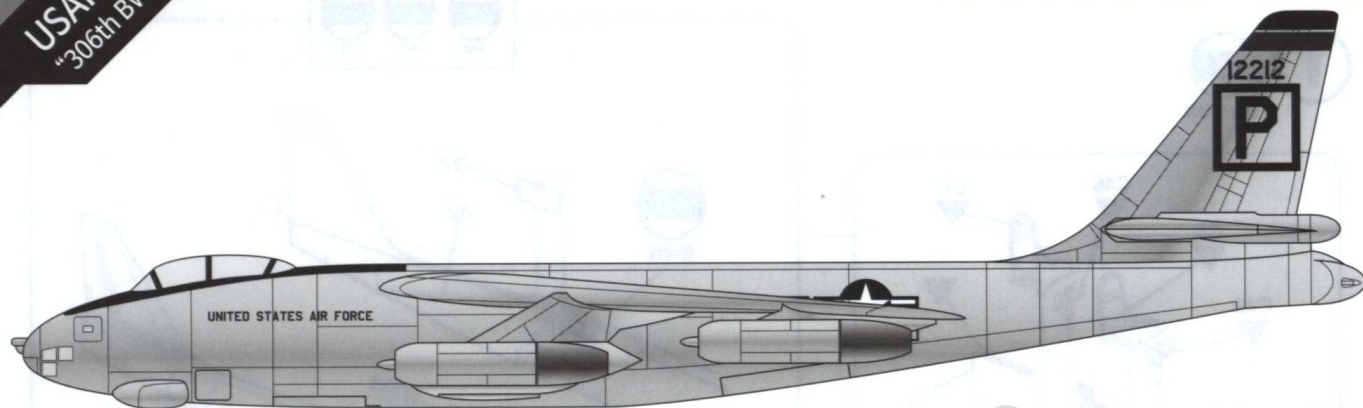

12618

**ACADEMY**  
HOBBY MODEL KITS

\* You can download the latest version of an instruction manual for this model by visiting [www.academyhobby.com](http://www.academyhobby.com), clicking the link for 'INSTRUCTION & DOWNLOAD' and entering the item number. 본 제품의 조립 중 궁금한 점은 [www.academy.co.kr](http://www.academy.co.kr) 접속 후 메뉴 '자료실' → '프라모델' 로 이동하여 해당 제품명을 입력하면 최신의 설명서를 확인 할 수 있습니다.

Warning in Assembly of Model Kits  
**조립전의 주의사항**

Take care not to injure yourself while using the modeling tools to cut or trim parts. 공구를 이용하여 부품을 다듬고 자를 때, 손, 눈을 다치지 않도록 주의를 기울여 주십시오.



**CAUTION!**  
**-주의-**

<READ THIS BEFORE YOU BEGIN>  
<ALLGEMEINE HINWEISE>  
<LISEZ CE QUI SUIT AVANT DE COMMENCER LE MONTAGE>  
<組み立てる前に>  
<조립하기 전에 먼저 읽어 주십시오>

**<READ THIS BEFORE YOU BEGIN>**

- Study the instructions before assembling. - Check the fit of each piece before cementing it in place.
- Do not use too much cement to join parts. - Never use cement or paint near open flame.
- Open a window or make area well ventilated when cement or paint is in use.
- Tear up and throw away the empty plastic bags to avoid danger of suffocation for little children.

**<ALLGEMEINE HINWEISE>**

- Die Anordnung der Bauteile ist aus den Zeichnungen der Anleitung ersichtlich.
- Die Teile vor dem Verkleben ungeleimt zusammenhalten, um ihren paßsitz zu prüfen.
- Klebstoff nicht zu dick auftragen. - Klebstoff und Farben niemals in der Nähe einer Flamme verwenden.
- Während der Bemalung mit Spritzpistole oder Pinsel für frische Luftzufuhr, z.B. öffnen des Fensters, sorgen.
- Bausatz von kleinen Kindern fernhalten. Verhüten Sie, daß Kinder in irgendwelche Bauteile in den Mund nehmen oder Plastiktüten über den Kopf ziehen.

**<LIREZ CE QUI SUIT AVANT DE COMMENCER LE MONTAGE>**

- Etudier les schémas d'assemblage. - Contrôler que chaque pièce soit bien conforme avant de la coller à sa place.
- N'utilisez pas trop de colle pour réunir les pièces. - Ne faites manipuler la colle ou peinture à proximité d'une flamme. Aérer soigneusement la pièce où vous peignez (ouvrir la fenêtre).
- Après avoir sorti les pièces du sac en plastique, déchirer le sac afin d'éviter que les enfants ne le mettent sur la tête et ne s'étouffent.

**<組み立てる前に>**

- 組み立てる前に説明書をお読み下さい。 - 部品をランナーから切りはなす時は模型用ニッパーとカッターを使用します。
- 接着剤を少しなめに使うことがきれいに仕上げるコツです。 - 接着する前に部品を合わせて確かめます。
- 接着剤や塗料を使用する時はときどき窓を開けて換気をお願いします。
- 組み立て後の部品やビニール袋は小さな子供の手の届かない安全な所に保管して下さい。

**조립하기 전에**

- 부품을 조립하기 전에 설명서를 잘 읽어본 후 조립한다.
- 접착하기 전에 부품을 맞추어 확인한 후 조립한다.
- 부품을 자를 때에는 칼이나 니퍼로 깨끗이 잘라준다.
- 접착제를 사용할 곳과 사용하지 않는 곳에 주의하고 너무 많이 바르지 않도록 한다.
- 에나멜 페인트나 접착제를 사용할 때는 창문을 열어 환기를 시키고 화기를 멀리한다.
- 사용 후 남은 부품은 어린 아이들의 손에 닿지 않도록 잘 처리한다.



접착제 사용



접착제 금지



수만축 조립



전사지



무게추



채움



잘라냄



선택



반대축 조립



뚫어줌



주의



버전

MAIN COLOR		1 BLACK FS 17038 검은색				3 SILVER FS 17178 은색				5 STEEL FS 17200 스틸			
PAINT INDEX		Humbrol		GSI Creos		Lifecolor		TESTORS / MODELMASTER		Revell		Vallejo	
		ENAMEL	ACRYL	AQUEOUS HOBBYCOLOR	Mr. COLOR			ENAMEL	ACRYL	ENAMEL	ACRYL	MODEL COLOR	MODEL AIR
1	BLACK FS 17038	21	21	H2	2	LC72	1747	4695	32107	36107	861		검은색
2	FLAT BLACK FS 37038	33	33	H12	33	LC02	1749	4768	32108	36108	950	57	무광 검은색
3	SILVER FS 17178	11	11	H8	8	LC74	2914	4678	32190	36190	997	63	은색
4	GOLD	16	16	H9	9	LC75	1744	4671	32194	36194	996	66	골드
5	STEEL FS 17200	53	53	H18	28	LC76	1795	4681	32191	36191	863	72	스틸
6	ZINC CHROMATE FS 34151	151		H58	27	UA004	1715	4735			833	10	징크 크로메이트
7	GREEN FS 34079	91	91	H309	309		1710	4726	32167	36167	980	20	그린
8	WHITE FS 17875	22	22	H316	316	LC51	1745	4696	32104	36104	842		흰색
9	LIGHT GULL GRAY FS 36231	183		H315	315		1729	4692					라이트 걸 그레이



**1** CEMENT  
접착제 사용

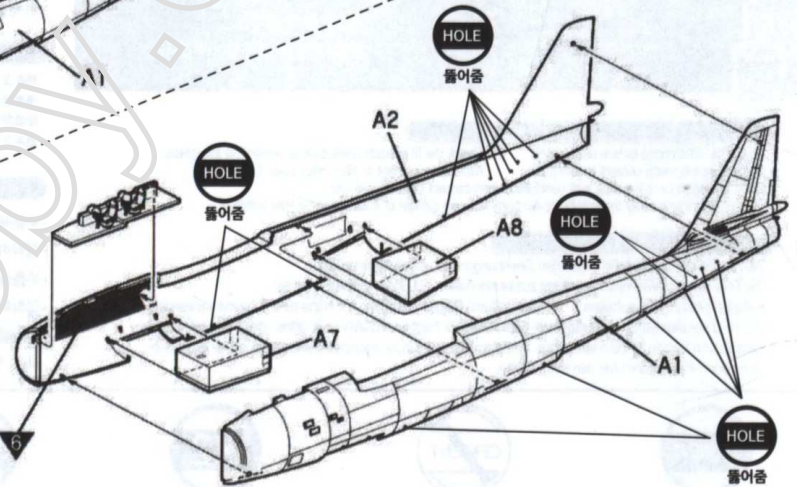
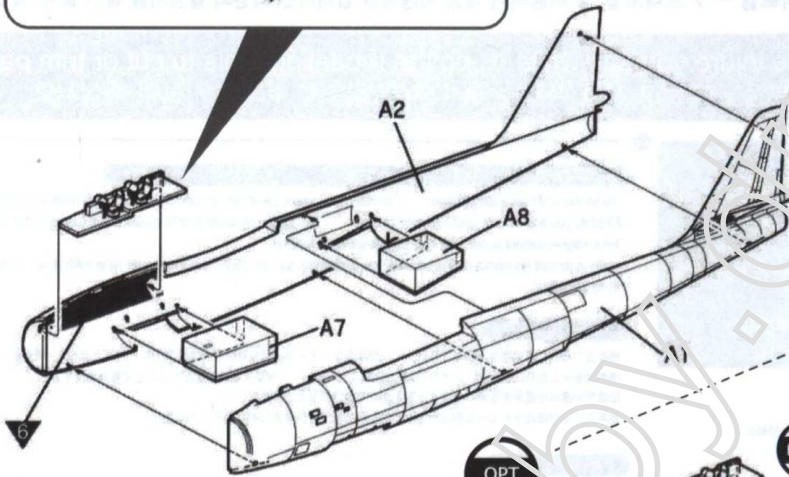
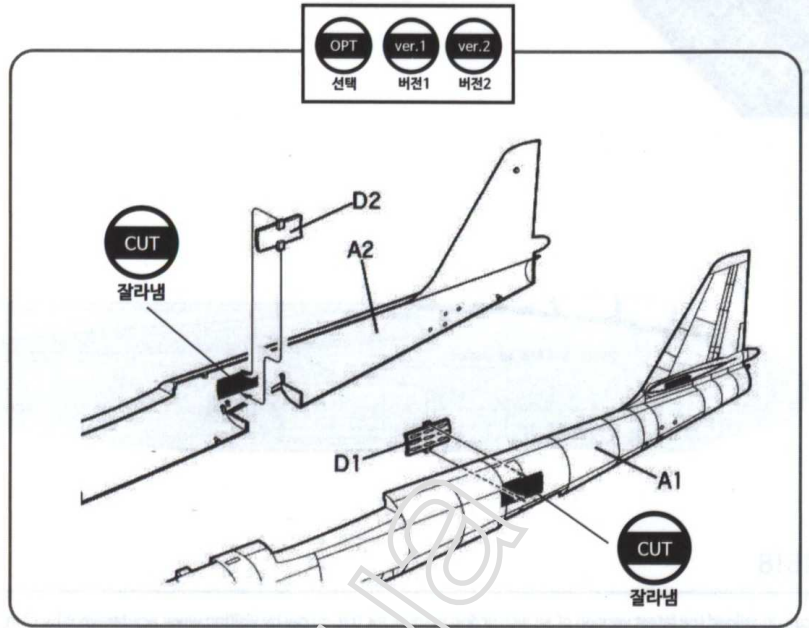
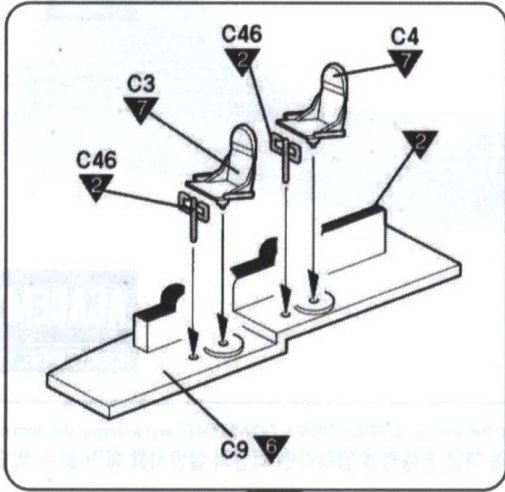

**2** CEMENT  
접착제 사용

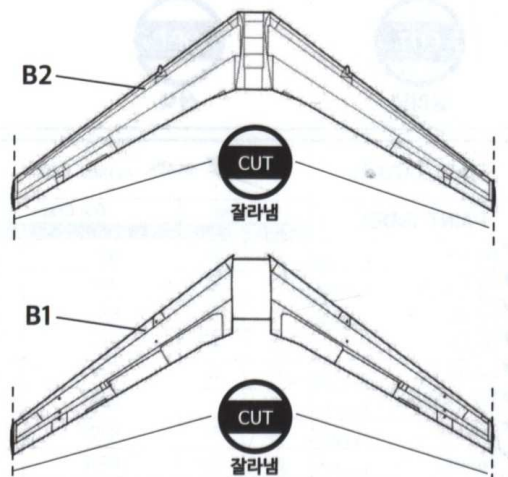
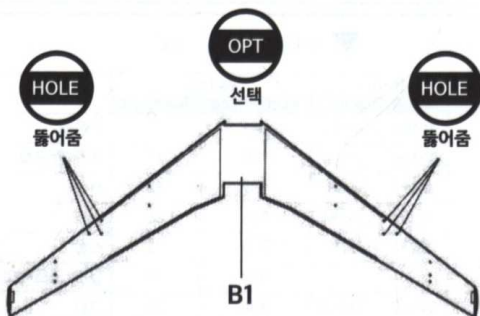



OPT 선택	ver.6 버전6	ver.7 버전7	HOLE 물어줌
-----------	--------------	--------------	-------------

**3** CEMENT  
접착제 사용

ver.1 버전1	ver.2 버전2	ver.3 버전3
--------------	--------------	--------------

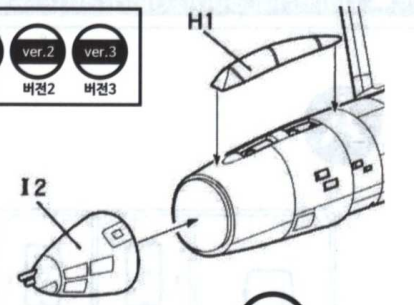
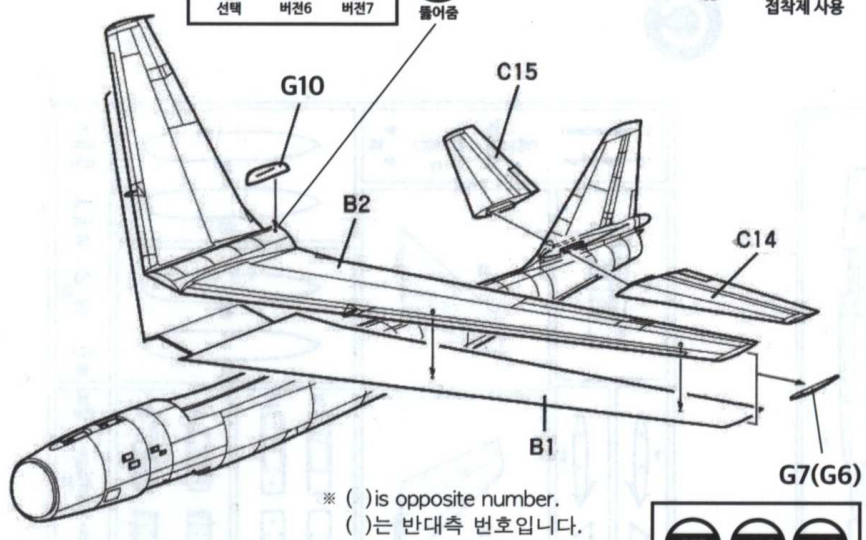

ver.6 버전6	ver.7 버전7
--------------	--------------

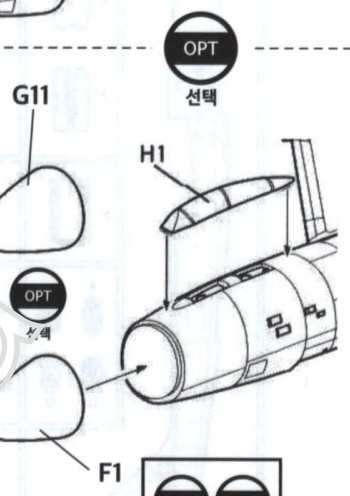

**4** CEMENT  
접착제 사용

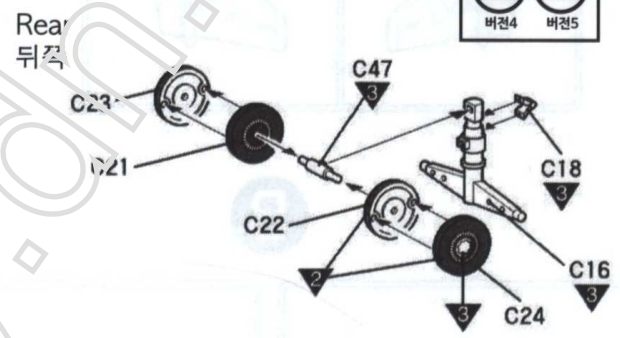
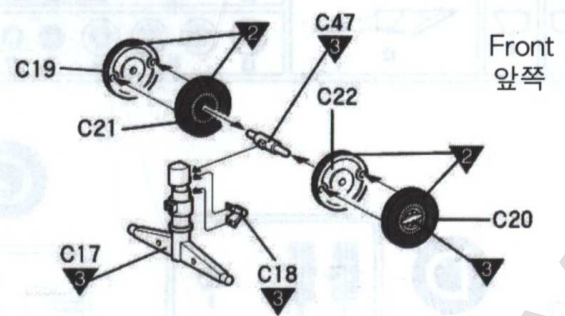

**5** CEMENT  
접착제 사용

※ Start assemble with number ①  
①번부터 조립 합니다.

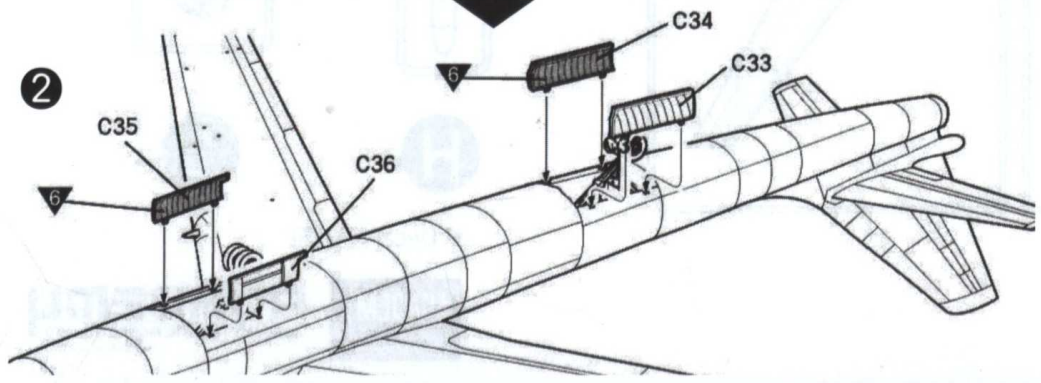
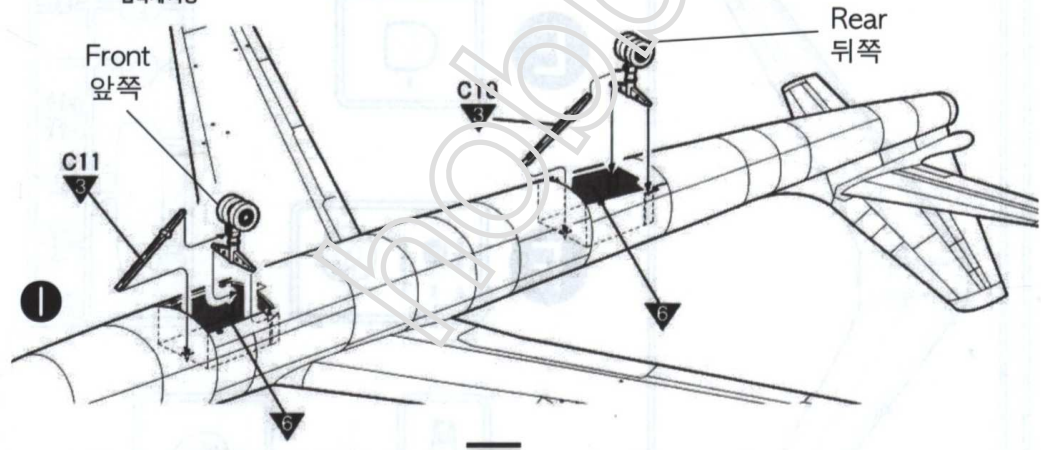

OPT 선택	ver.6 버전6	ver.7 버전7
-----------	--------------	--------------

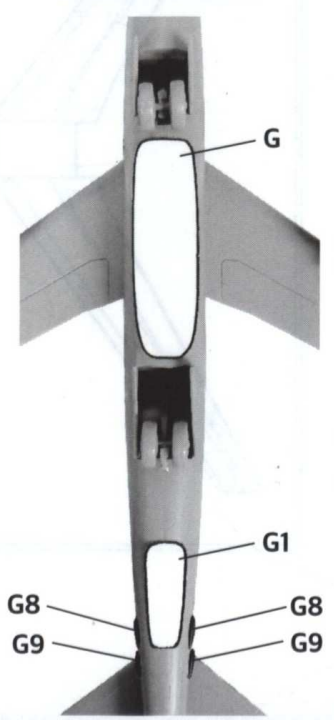



6

CEMENT  
접착제 사용

※ Start assemble with number 1  
1번부터 조립 합니다.

1

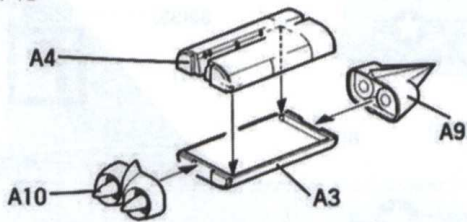

1

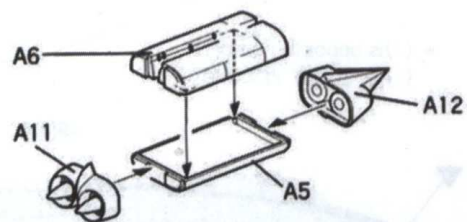

A

2

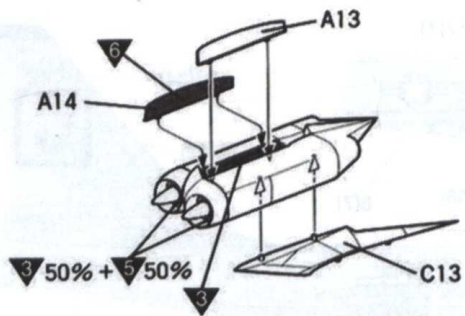

B

2

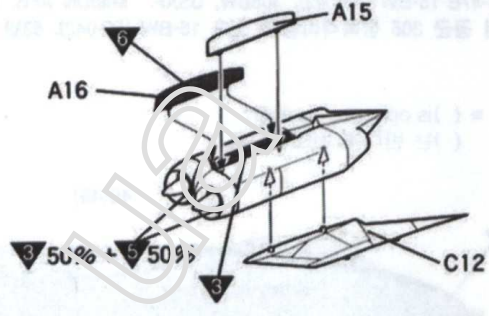

7

CEMENT  
접착제 사용

C

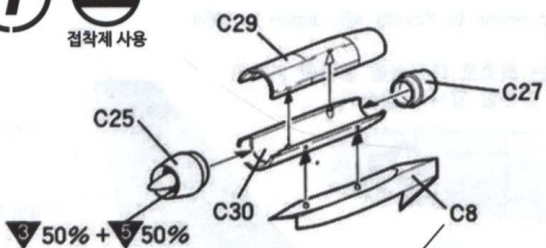

D

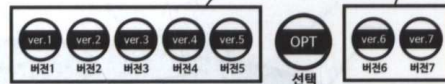
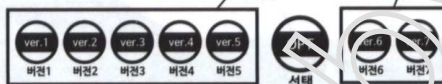
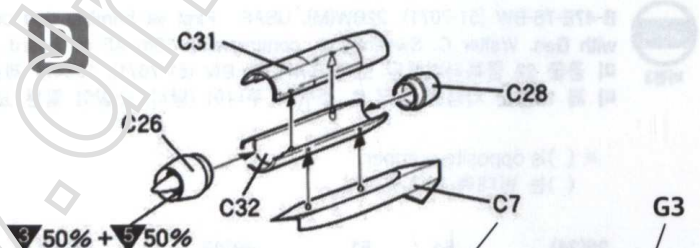

E

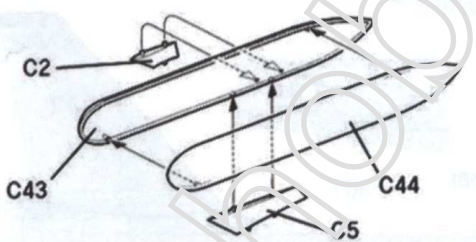

F

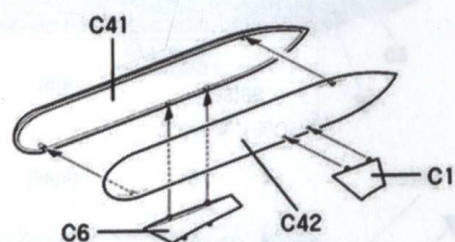

8

CEMENT  
접착제 사용

C

A

E



OPT  
선택

G2

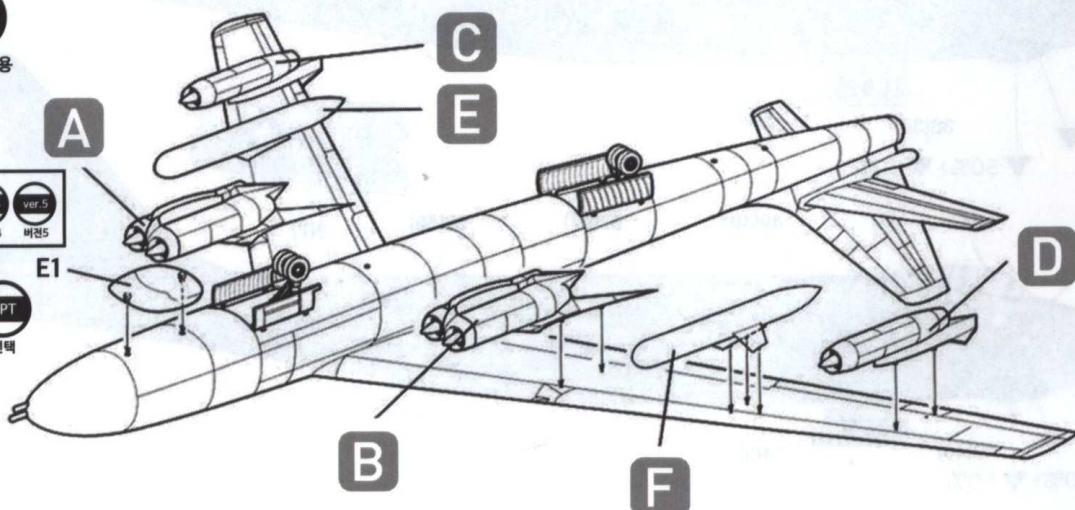

9

CEMENT

접착제 사용

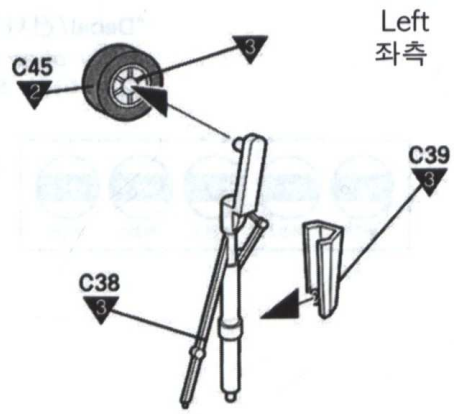
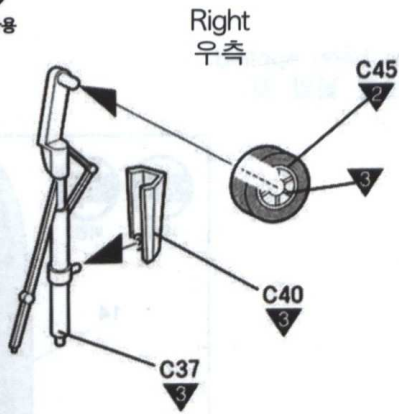

10

CEMENT

접착제 사용

OPPOSITE

반대측 조립

Right  
우측

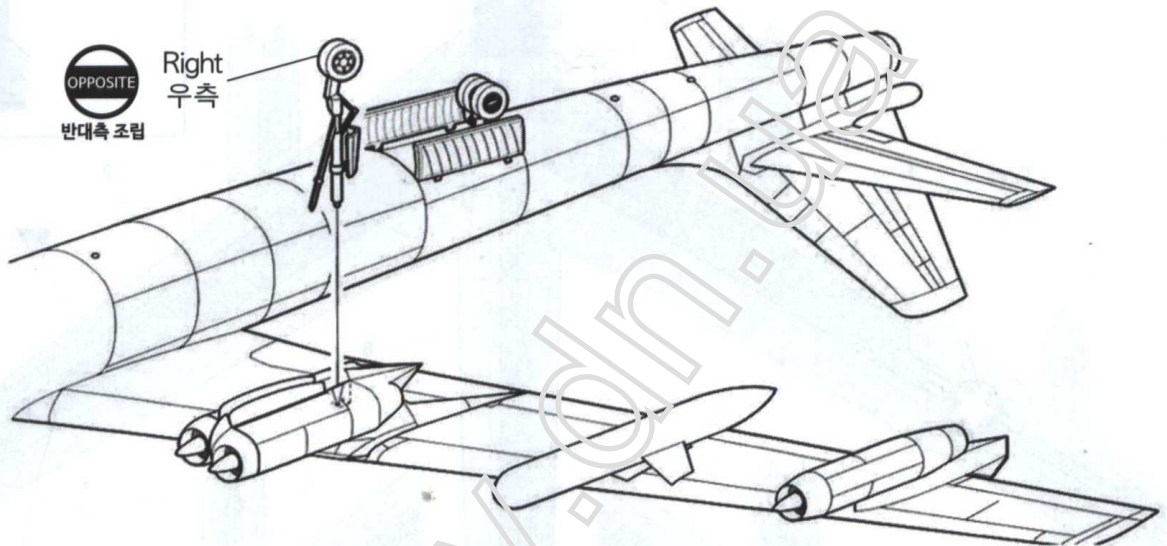

CAUTION

주의

\*Outriggers adjustment  
주날개 보조 바퀴 길이 조정

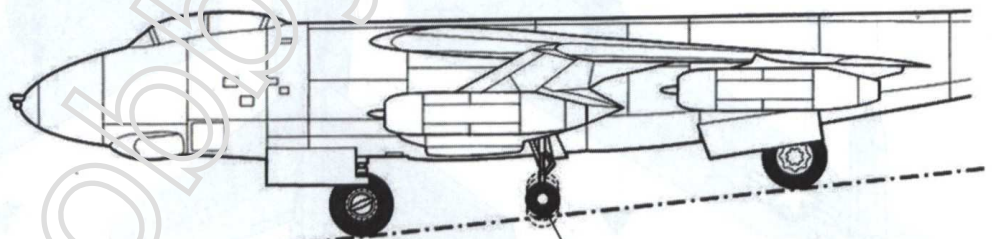
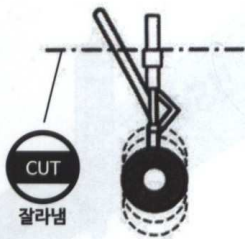

\*Adjust  
높이에 맞추어 길이를 조정해 주세요.

11

CEMENT

접착제 사용

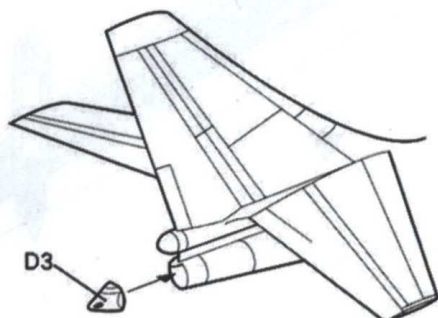
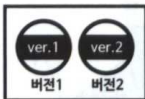

OPT  
선택

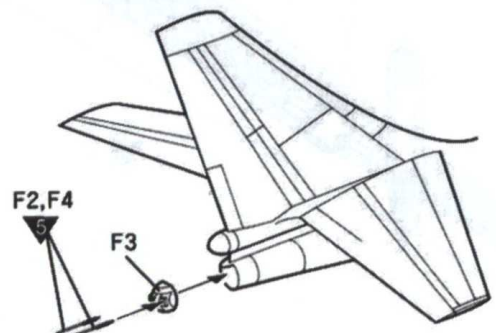



● USAF B-47

\*Decal/전사지: 13, 14

Apply after all other markings have been applied.

다른 마킹 작업이 끝난 후 마지막으로 붙일 것.

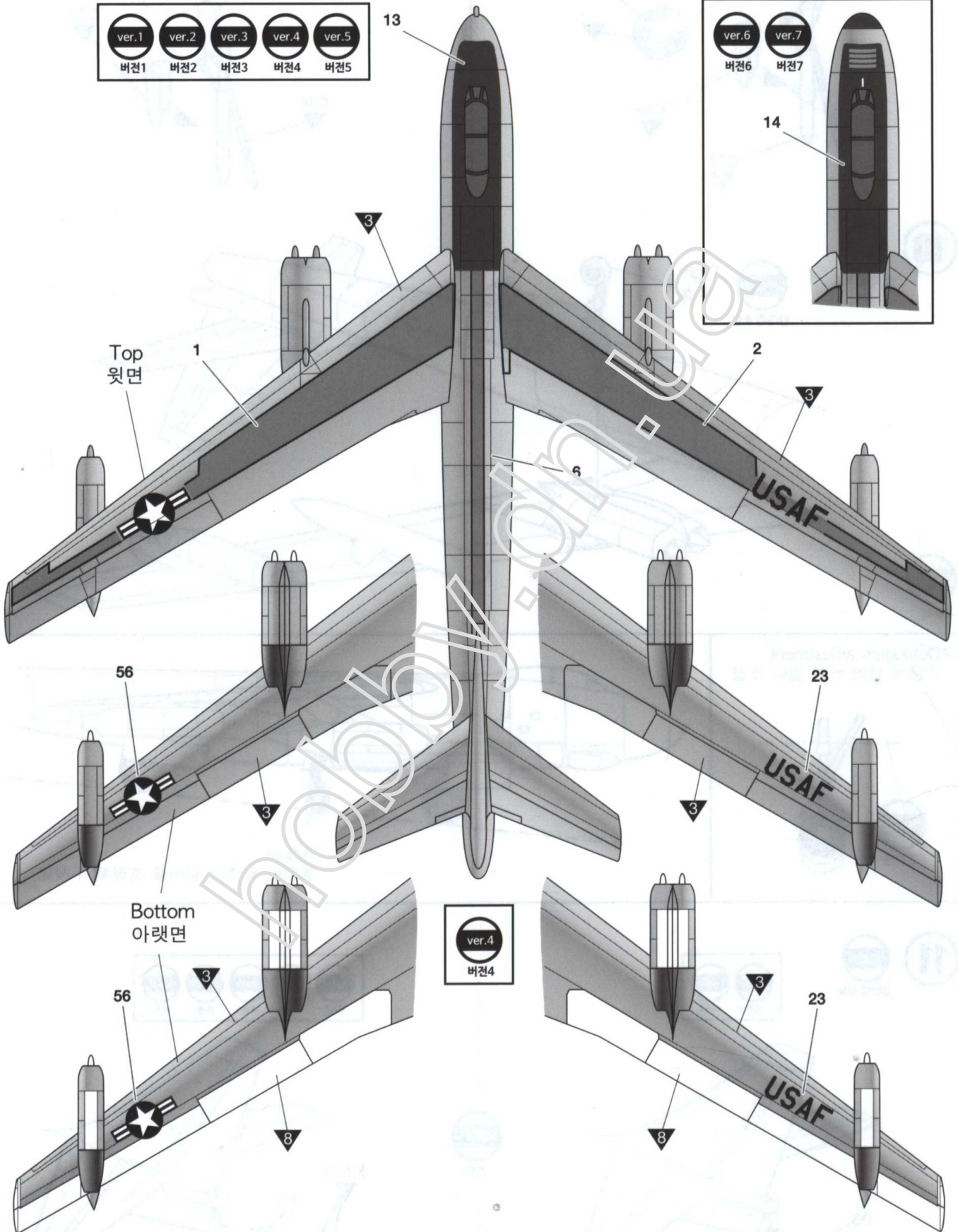
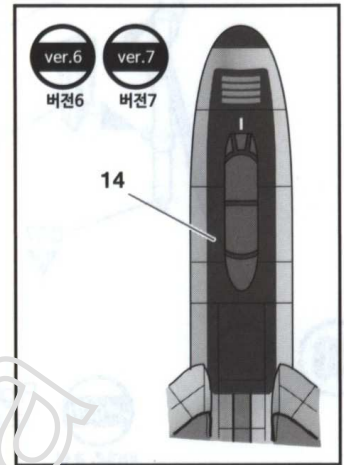

ver.1

B-47B-40-BW (51-2212), 306BW(M), USAF. MacDill AFB, Florida, early 50s.  
미 공군 306 중폭격비행단 소속 B-47B-40-BW (51-2212). 50년대 초, 플로리다 맥딜 공군기지.

버전1

※ ( ) is opposite number.  
( )는 반대측 번호입니다.

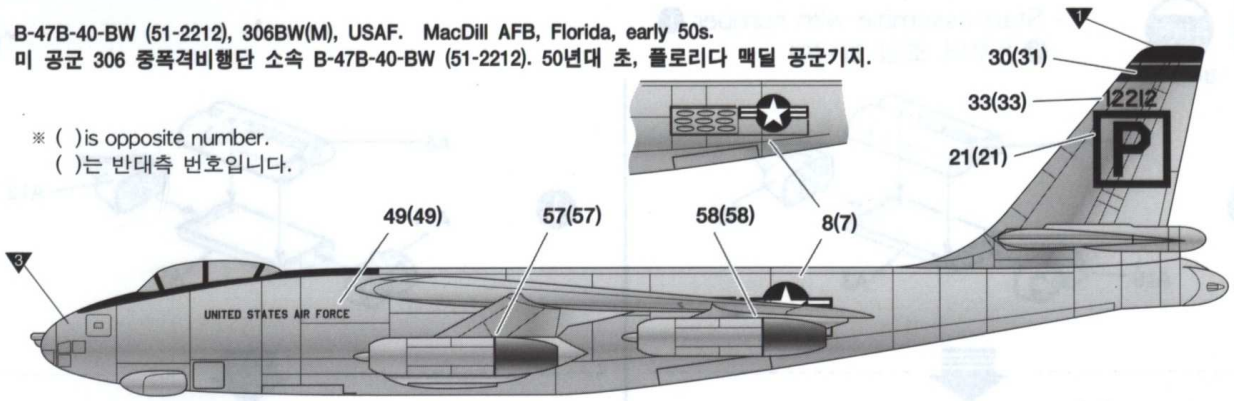

ver.2

B-47B-15-BW (50-042), 305BW, USAF. MacDill AFB, Florida, Early 1953.  
미 공군 305 중폭격비행단 소속 15-BW (50-042). 53년 초, 플로리다 맥딜 공군기지.

버전2

※ ( ) is opposite number.  
( )는 반대측 번호입니다.

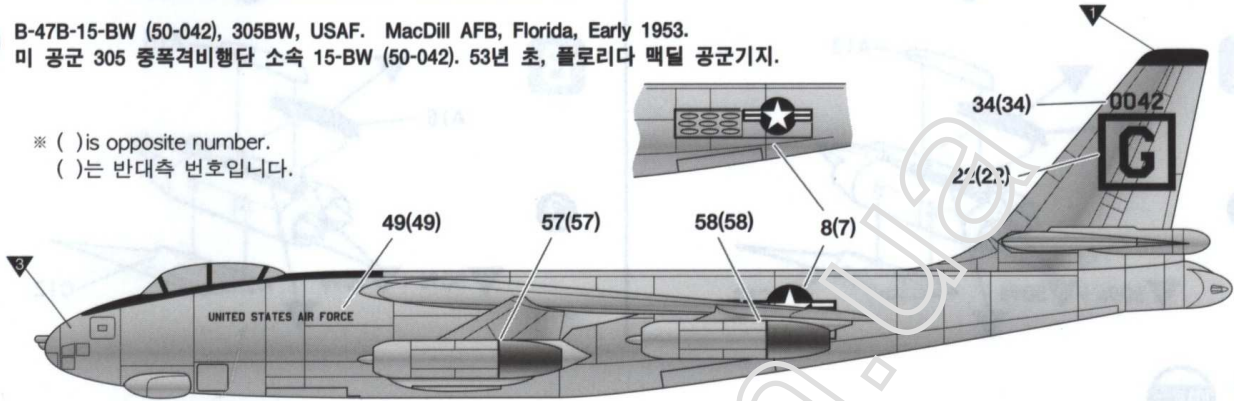

ver.3

B-47E-75-BW (51-7071), 22BW(M), USAF. First jet bomber that crossed Pacific ocean to Yokota AB, Japan in 1954 with Gen. Walter C. Sweeney Jr. commanding 15th AF on board.

미 공군 22 중폭격비행단 소속 B-47E-75-BW (51-7071). 1954년 제트폭격기로서는 최초로 태평양을 횡단한 기체로 미 제 15공군 사령관 월터 C. 스위니 주니어 (당시) 소장이 일본 요코타 기지를 방문할 당시의 탑승기.

버전3

※ ( ) is opposite number.  
( )는 반대측 번호입니다.

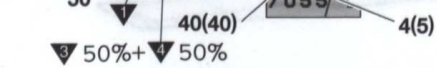
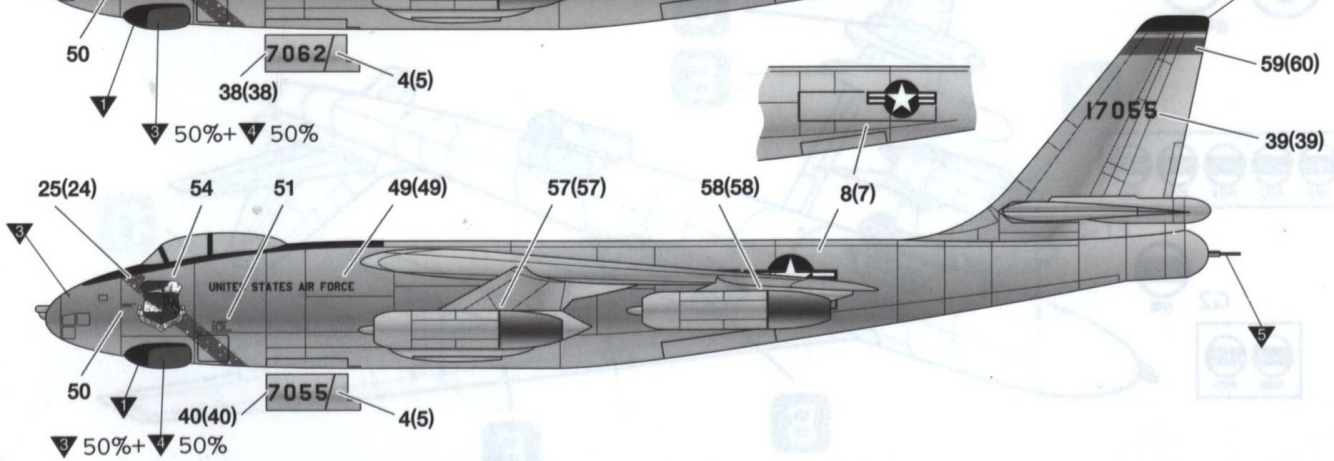
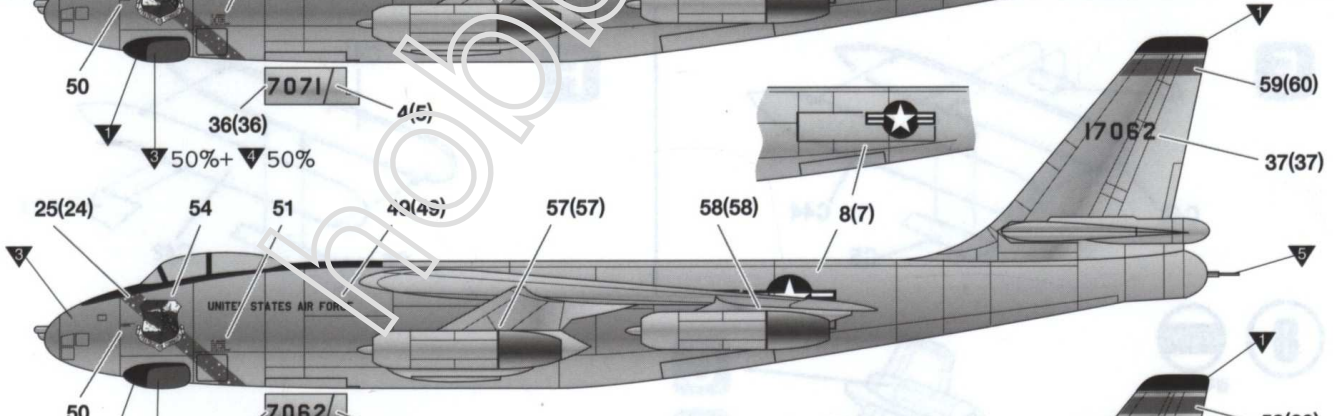



**A**

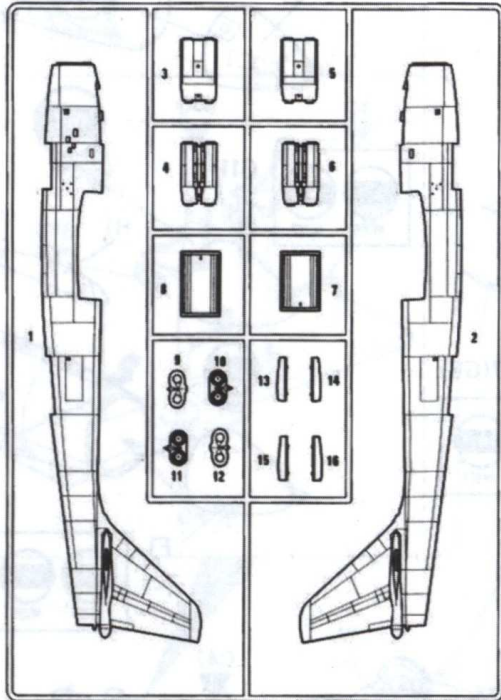

**C**

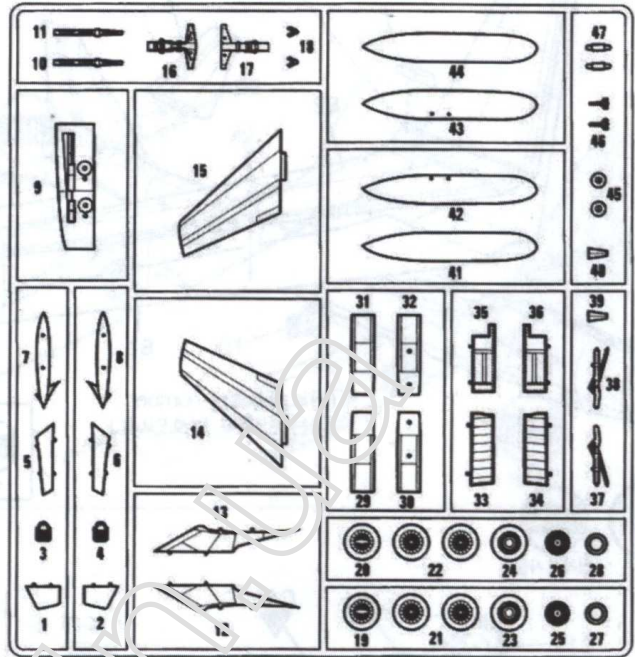

**B**

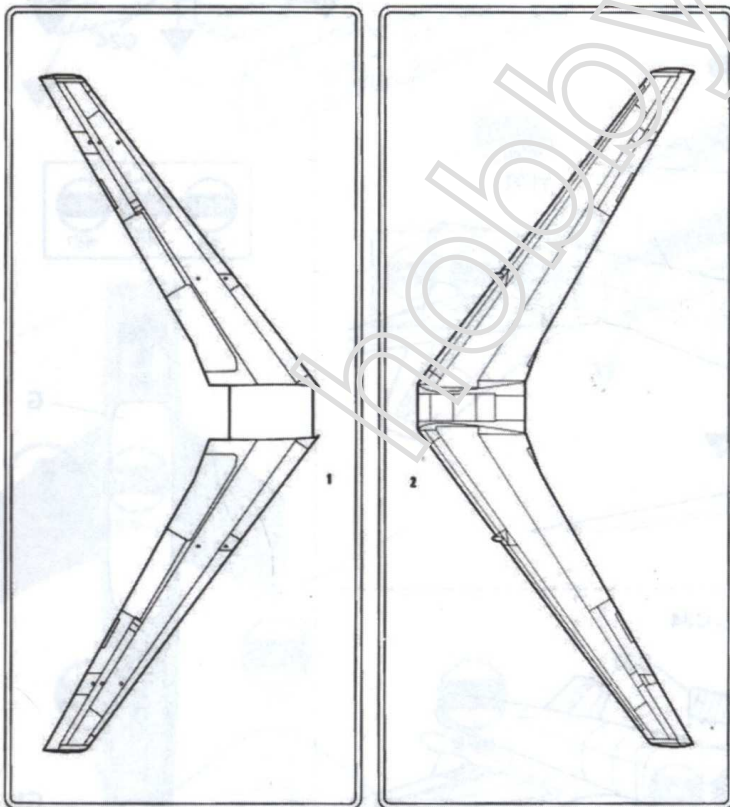

**G**

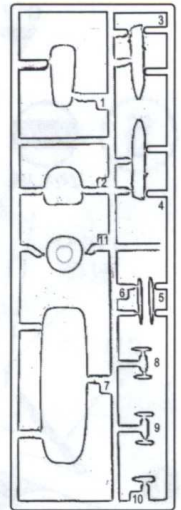

**D**

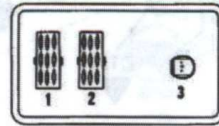

**E**

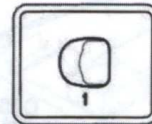

**F**



**H**

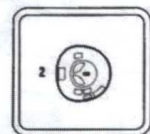

**I**

● Decal / 전사지



ver.4  
버전4

B-47B-II (51-2324), Updated to B-47E standard, 305BW(M), USAF. MacDill AFB, Florida, 1954.  
B-47E 사양으로 개수된 미 공군 306 중폭격비행단 소속 B-47B-II (51-2212). 1954년, 플로리다 맥딜 기지.

※ ( ) is opposite number.  
( )는 반대측 번호입니다.

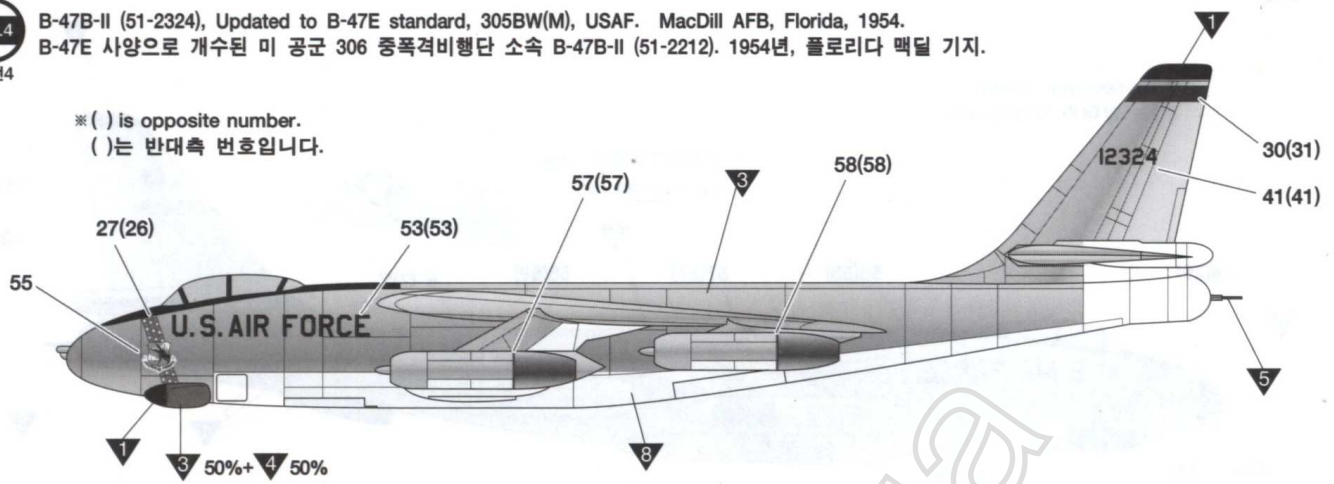

ver.5  
버전5

B-47B-II (51-2336), Updated to B-47E standard, 320BW(M), USAF. March AFB, California, 1959.  
B-47E 사양으로 개수된 미 공군 320 중폭격비행단 소속 B-47B-II (51-22336). 1959년, 캘리포니아 마치 기지.

※ ( ) is opposite number.  
( )는 반대측 번호입니다.

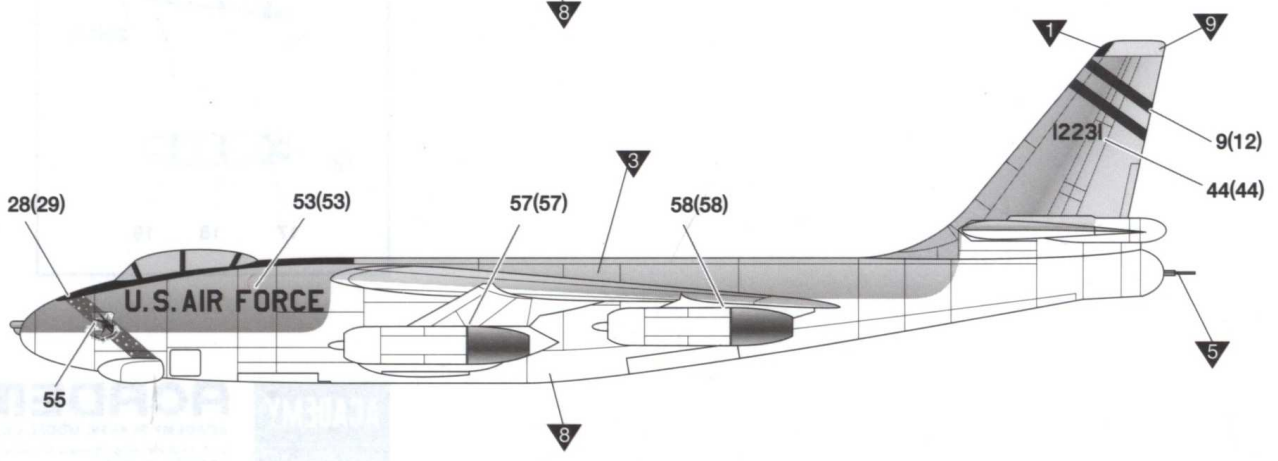
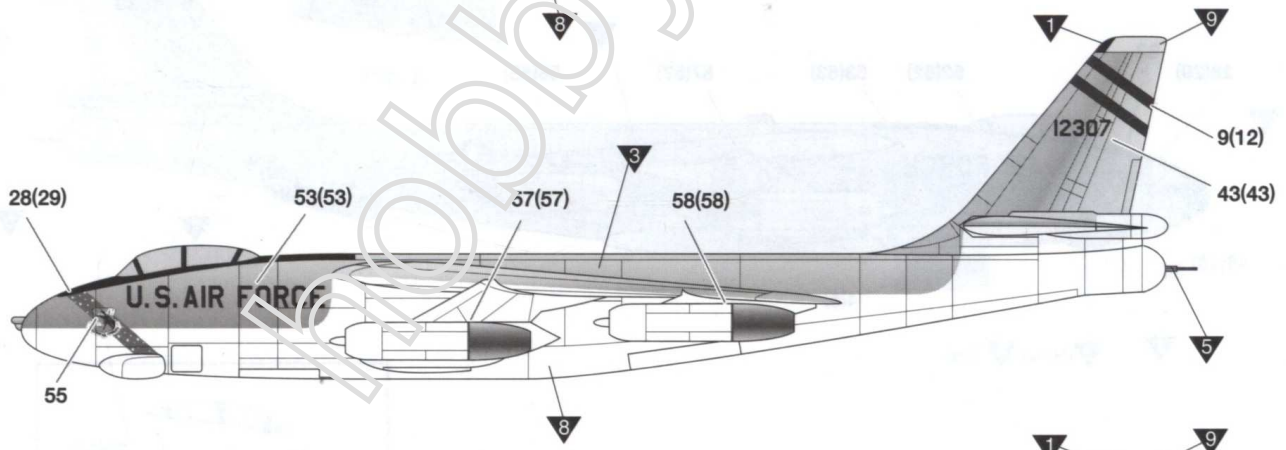
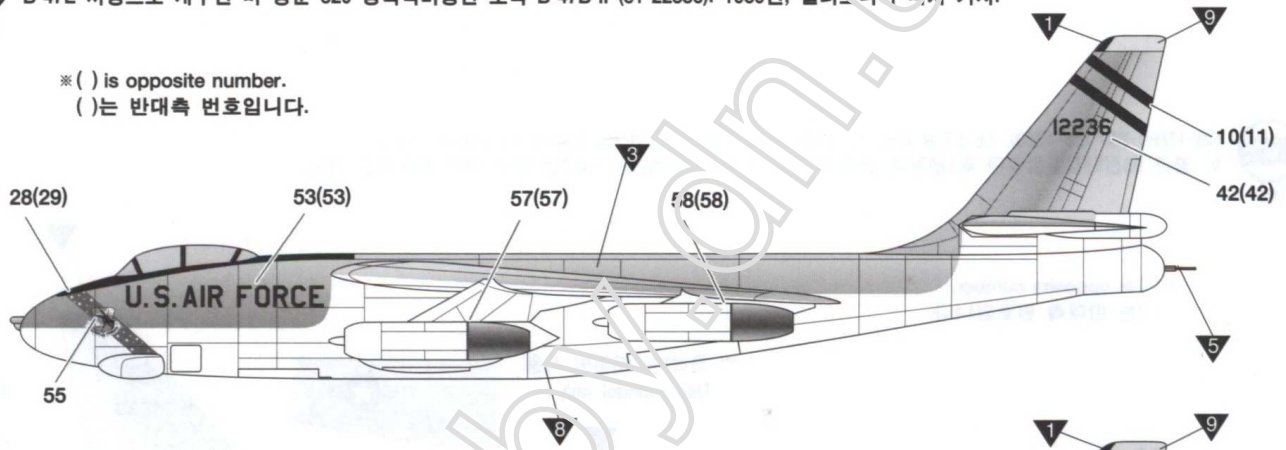



ver.6  
버전6

RB-47H-1-BW (53-34291), 55 SRW Det. 2, USAF. Yokota AFB, Japan, 1965.  
미 공군 55전략정찰항공단 제2분견대 소속 RB-47H-1-BW (53-34291). 1965년 일본 요코타 기지.

※ ( ) is opposite number.  
( )는 반대측 번호입니다.

\*\* : 국적마크부분만 사용  
Use roundel only

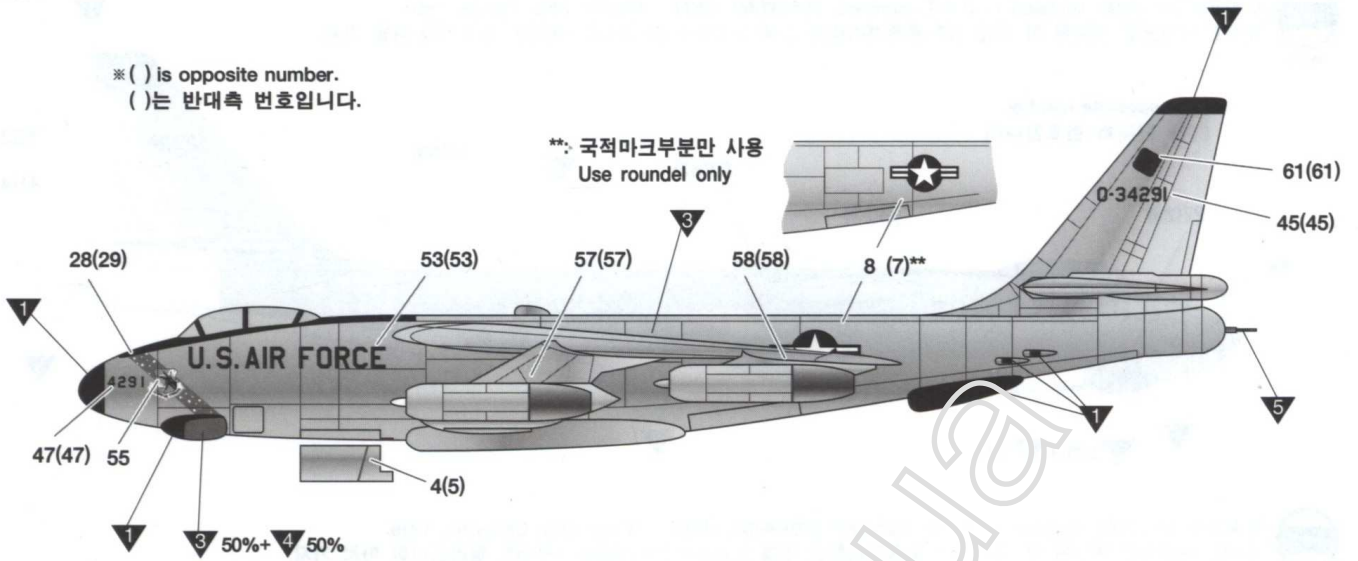

ver.7  
버전7

RB-47H-1-BW (53-4280), 55 SRW Det. 1, USAF. RAF Upper Heyford, United Kingdom, 1967.  
미 공군 55전략정찰항공단 제1분견대 소속 RB-47H-1-BW (53-4280). 1967년 영국 어퍼 헤이포드 기지.

※ ( ) is opposite number.  
( )는 반대측 번호입니다.

\*\* : 국적마크부분만 사용  
Use roundel only

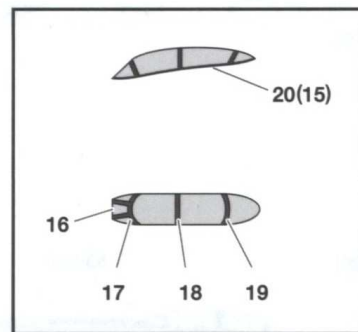
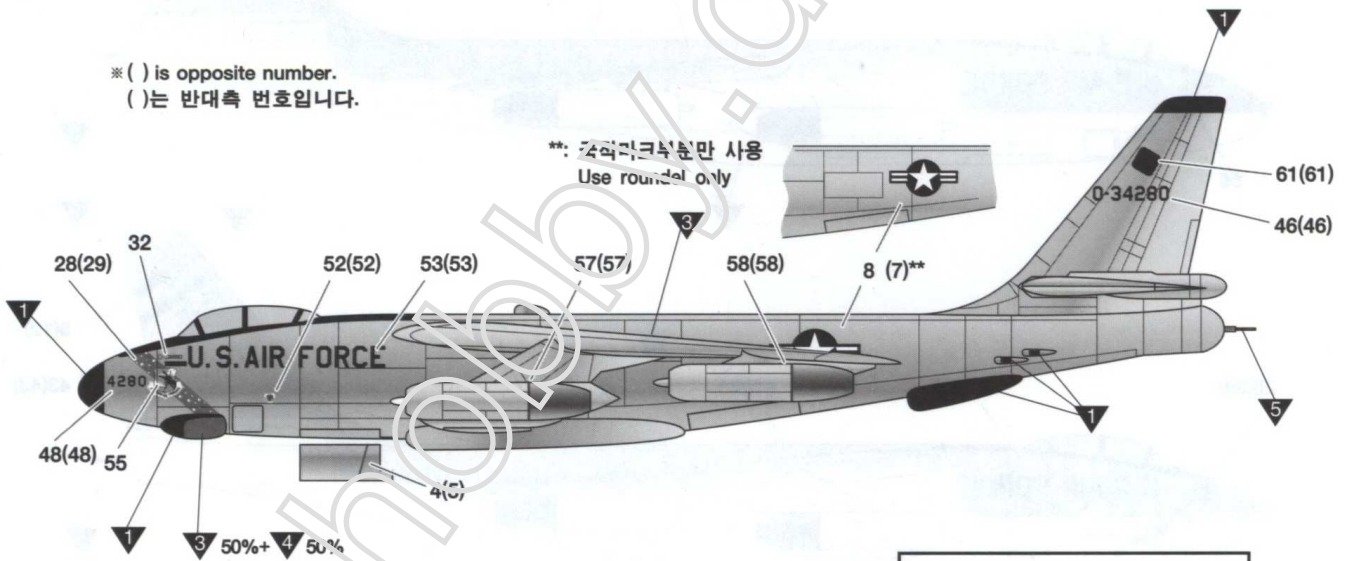

ACADEMY  
HOBBY MODEL KITS

ACADEMY  
ACADEMY PLASTIC MODEL CO., LTD.  
521-1, Yonghyeon-dong, Uijeongbu-si, Gyeonggi-do, Korea  
고객상담문의 : 031-850-8555