



M24

Light Tank "Chaffee"

M24霞飛輕戰車

WWII



M3/5 Stuart light tanks were deployed in mass number in every battle front during the world war two, however limited by its own conception of designing to supporting the infantry and being the role of cavalry, it has narrow compartment space, its own 46.75 inches turret ring can not be fitted in with more larger caliber cannon, the 37mm main gun and engine has been proved insufficient during the battle in north Africa, so after the campaign in north Africa, the role of the light tanks were constrained in recon and covering missions!

In January 1941 U.S.A army has began to search the project to replace Stuart light tanks, a prototype named T7 which equipped with traditional suspension Vertical Volute Spring Suspension briefed as VVSS, and once armed with 37mm,57mm during the testment, the final prototype armed with 75mm cannon got its own official name "M7" on August 1942, but it weighted nearly 25 tons, it is too heavy for light tank, so that it is reconsidered as the middle tank! M7 was in limited production till March 1943. In April 1943 U.S.A. army department request Cadillac Car Sector to research for their new project of light tanks limited under 20tons, the code of the prototype named T24, its chassis adopted with newly developed torsion bar suspension system, armed with M6 75mm main gun which revised form the gun equipped on B-25H bomber, M6 main gun can also use the ammunition the same as M4 tank, but it only got half the weight as M3 main gun which used by M4. T24 don't have the turret basket, and its original design only got 4 crews, the radio operator have to climb into the turret to serve as the loader during the fight, sooner it is redesigned into five crews, after WW2 with the improvement of the radio, the radio operator no longer needed, so some of M24 were modified into 4 crews again! On the end of 1943 the army authority were satisfied by the performance of T24, sooner it was put into the mass production totaled 4415 were made from March 1944 till August 1945, and got its official code M24 in July 1944.

In November 1944 the first shipment of M24s arrived at Europe, they were put into the fight in "Ardennes Offensive" for the first time, they matched to strength with German panzers by their 75mm main gun. Meanwhile some of M24s were also supplied to British army due to "Lend Lease Program", followed by British army tradition. M24 was named after "Adna Romanza Chaffee, Jr." as Chaffee the "Father of the Armored Force of U.S.A.". M24 light tank is considered as the best light tank ever used in WW2 by its good fire power and armor.

M3/5 スチュアート軽戦車は、第二次大戦期間中、ほぼすべての地域で大量に配備され使用された。しかし、歩兵支援と騎兵の役割という発想に基づいた設計は、やがて限界を露呈することとなる。狭い車輻空間に収める、46.75インチの砲塔リング径は、より大きな砲の搭載を阻害していた。そして、北アフリカでの戦闘によって、37mm砲の威力やエンジン出力が絶対的に不足していることが証明され、この戦いで降参したM3/5系軽戦車は、偵察と護衛任務程度にしか使用できなかった。1941年1月アメリカ陸軍は、スチュアートに変わる新戦車に関する調査を開始した。伝統的なVVSSサスペンションを装備した試作車T7は、テスト期間中に、37mm砲、57mm砲を搭載、最終試作型では75mm砲を搭載し、1942年8月、正式名称 "M7" を与えられた。しかし、25トンの近い重量は軽戦車としては重すぎ、中戦車として再考されることになった。結局M7は少量の生産にとどまり、1943年5月にその開発は中止された。

1943年4月、アメリカ陸軍はキャデラック社に対し、重量20トン以下の新型軽戦車計画に関する調査を命じた。T24と呼ばれる試作車は、新開発のトーションバーサスペンションを搭載した車体を持ち、B-25H爆撃機に搭載されていた砲を改造したM6/75mm砲を主砲として装備していた。この砲は、M4中戦車搭載のM3/75mm砲と砲弾を共用できるように、M3戦車砲の半分の重量というメリットがあった。T24は、砲塔バスケットを持たず、最初の設計では乗員は4名のみであった。そのため戦闘時に無線手が車体から砲塔内に這い上がり、装填手の役割を果たさねばならなかったため、すぐに乗員は5名に設計変更された。この点は第二次大戦後、無線器の進歩によって無線手の存在が不要になり、再び4名乗車に改装された車輛もあった。1943年末、T24の性能に満足したアメリカ陸軍は、すぐに量産を開始。1944年3月から1945年4月までの間に合計4415輛が生産され、1944年7月には正式にM24の名称が与えられた。

1944年11月、M24軽戦車の第一陣がヨーロッパに到着し、初めての戦闘で「アルデンヌの戦い」に投入され、75mm砲はその威力を発揮し、ドイツ軍戦車と対等に渡り合った。また、レンドリース法に基づいて、何輛かのM24がイギリス軍に供給され、「米機甲部隊の父」といわれた「アドナ・ロマンザ・チャーフィー」にちなんで、「チャーフィー」と名づけられた。M24軽戦車は、砲の威力と適度な装甲により、第二次大戦中最良の軽戦車といわれている。

在二次大戦期間活躍於各個戰場的美國M3/M5史都華輕戰車，其車身佈局承襲自戰前為步兵、騎兵所開發的輕戰車，由於史都華輕戰車內部空間狹窄，46.75吋的砲塔環直徑也不足以升級更大口徑的火箭，受限於既有的37毫米口徑火箭性能，與發動機動力不足等問題，於北非的戰役之後，輕戰車便被限縮於執行偵察與掩護任務上。

在1941年1月美國陸軍開始尋找史都華輕戰車的替代方案，一個名為T7的原型車輛，採用傳統的立式渦形彈簧懸吊(VVSS)，在試驗階段分別搭載了37、57與75毫米的火箭，最終的試作車在1942年8月取得制式型號M7，但重量已接近25公噸被劃入了中型戰車的範圍，在經過少許的量產之後於1943年3月計畫中止。1943年4月軍方將新戰車的研發委由凱迪拉克汽車部門進行，車重被限制在20公噸以下，原型車的代號是T24，車體採用了新穎的扭力桿懸吊，搭載的M6戰車砲為改良自B-25H轟炸機的75毫米砲，能使用與M4雪曼中戰車相同的彈藥，但重量尚不及雪曼所使用的M3戰車砲的一半。T24沒有砲塔吊籃，原始的設計為四名乘員，無線電手在戰鬥中必須爬進砲塔充當裝填手，但這個想法很快被打消，改為五名乘員的配置，直到戰後部分使用國對車內空間布局進行改良，又恢復成為四名乘員。到了1943年底，T24的測試令軍方滿意，由1944年3月至1945年8月共生產達4415輛之譜，並在1944年7月獲得制式型號M24。

M24最初到達歐洲是在1944年11月，在稍後的突出部作戰中首度投入戰鬥，憑藉著75毫米主砲而取得能與德國戰車周旋的實力。同時也因租借法案的原故，部分M24供給英國陸軍使用，並依英國人的傳統以美國裝甲兵之父阿德納·霞飛之名為它命名為「霞飛」，堪稱為二次大戦中火力與防護力最為優秀的輕戰車。

M24 "Chaffee" Light Tank



M-24 was a light tank mounting a 75mm tank gun that was originally developed for B-25 bomber. Debuted and deployed in late part of WWII. Later, M24 encountered its real combat during the Korean War.

Caterpillar tracks

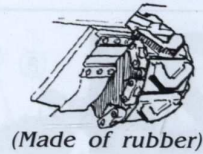

Double-pin type T85E1

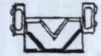

Single-pin type T72

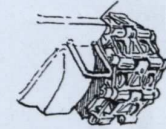

(Made of steel)

M19 gun motor carriage

Twin 40 mm anti-air cannons

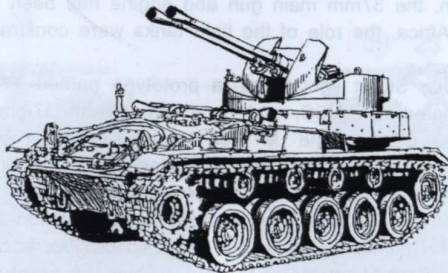

Later, M41 entered service in US army and M24 was widely used by many NATO nations and other countries such as France, Italy, Vietnam, South Korea, Republic of China (Taiwan), Japan and so on.



M37 105 mm howitzer motor carriage

M37 was developed to replace M7 Priest.

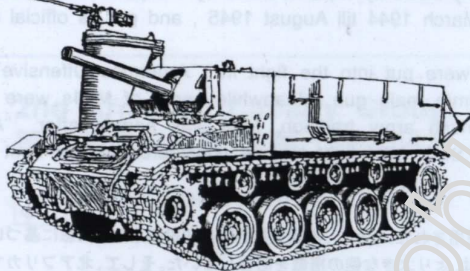

M24 equipped with M4 bulldozer

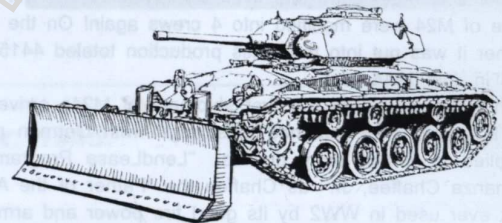

T6E1 tank recovery vehicle

Equipped 81 mm mortar to deploy smoke screen.



M41 155 howitzer motor carriage

M41 and M37 both debuted during the Korean War.

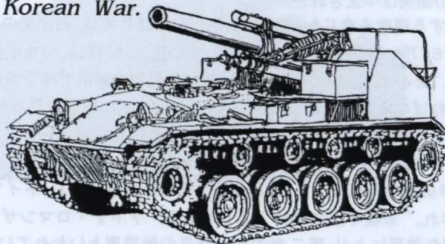

NM-116

Norwegian Army modified version original 75 mm tank gun was replaced with a 90 mm tank gun coaxial 12.7mm M2 heavy machine gun.

Engine was replaced with a diesel engine

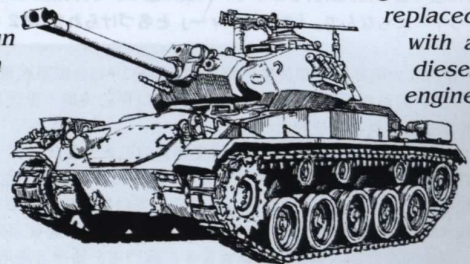

T77E1 multiple gun motor carriage

Equipped with 6 12.7mm M2 heavy machine guns.



Shin.ueda

上田 信

Illustration:圖示說明



Method For Applying Decals:

1. Clean Model Surface With Wet Cloth.
2. Cut Out Of Decal Sheet And Dip Them In Warm Water For 15 Seconds.
3. Place it on proper position on model.
4. Slide off base paper leaving decals On Model With Wet Finger Tip.
5. Move Decals To Exact Position, Push Out Excess Water Under Decal With Soft Cotton Cloth.
6. When Decals Get Dry Then Complete.

水貼紙使用說明:

1. 將模型表面擦乾淨
2. 將貼紙剪下泡入溫水中浸泡約15秒
3. 將泡濕之貼紙取出置於欲貼處旁
4. 用指尖輕推貼紙表面使其滑出底紙
5. 將貼紙調整至適當位置並輕擦拭水份
6. 待其自然乾燥後即完成

Color list: 塗料表

Color	Brand	Gunze Sangyo			Humbrol	Revell	Lifecolor
		Hobby Color	Mr.Color	Mr.Color Spray			
Black	黑	H2	C2	J2	21	7	LC52
Brass	黃銅	H9	C9	J9	54	92	LC75
Field green FS34097	原野綠		C340		105	361	UF02
Flat black	消光黑	H12	C33	J33	33	8	LC02
Flat white	消光白	H11	C62	J62	34	05	LC01
Olive drab(2)	橄欖綠	H78	C38	J38	66	46	UA106
Red	紅	H3	C3	J3	19	31	LC56
Silver	銀	H8	C8	J8	11	90	LC74
Steel	黑鐵	H18	C28	J28	53	91	LC76
Tire black	輪胎黑	H77	C33+C62		85	302	LC02
Wood brown	木棕	H37	C3		169		FS12
Yellow	黃	H4	C4	J4	69	12	LC53

1

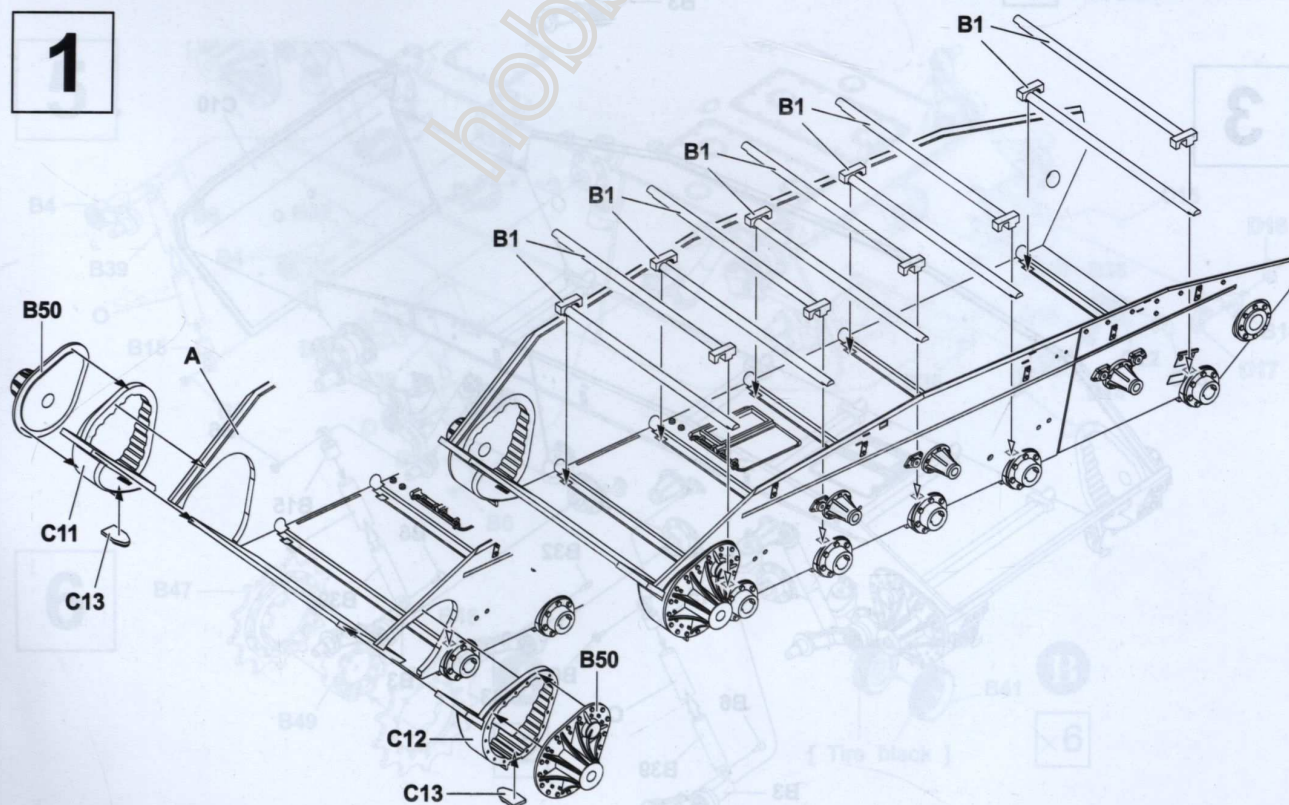

2

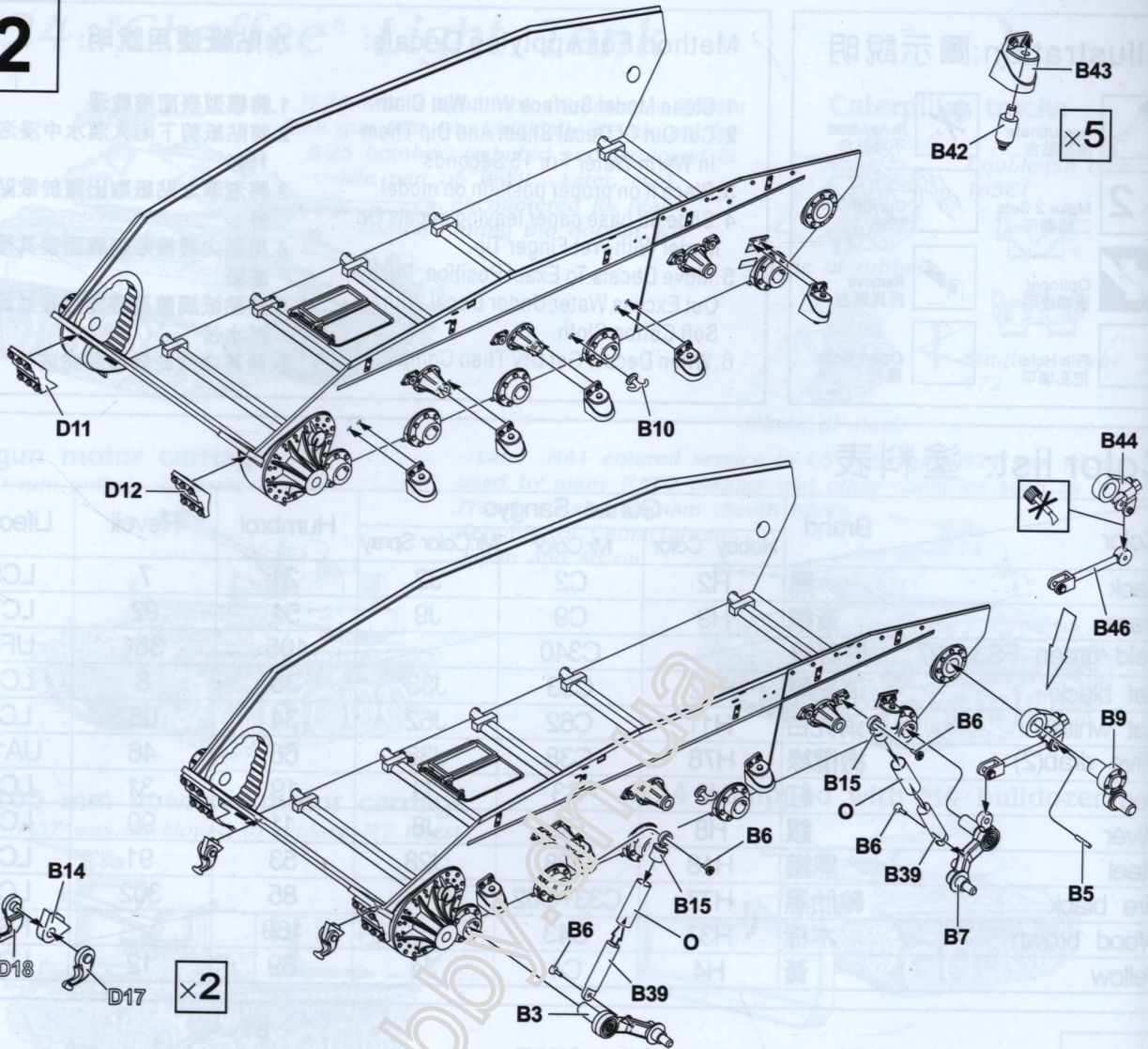

3

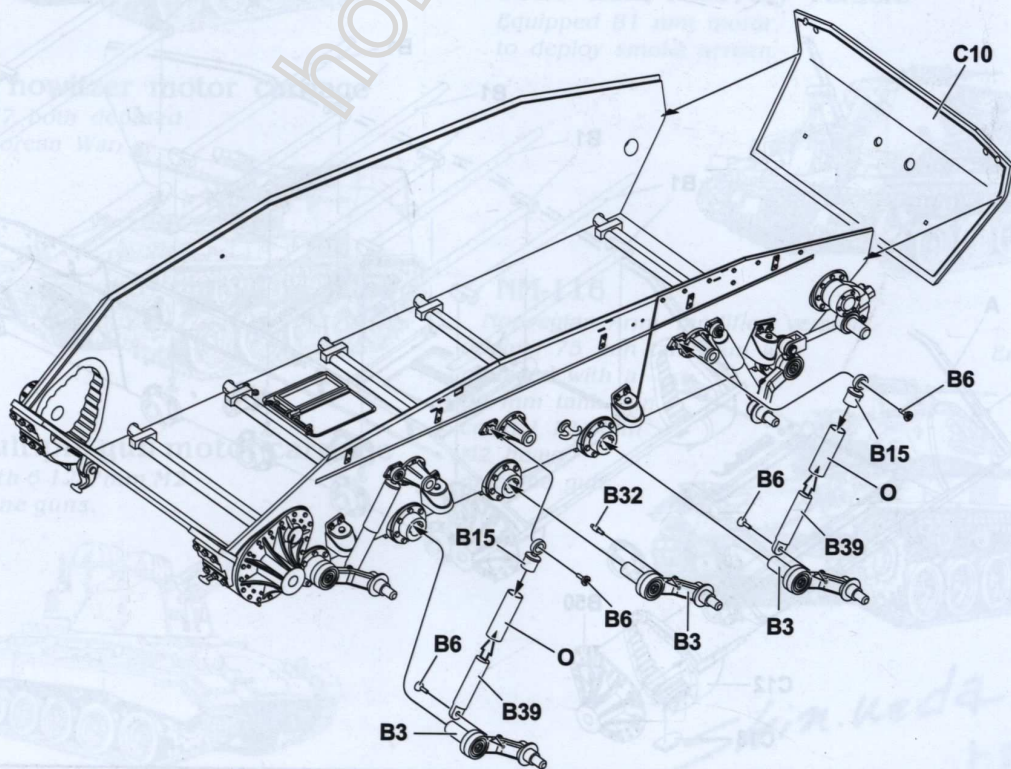

4

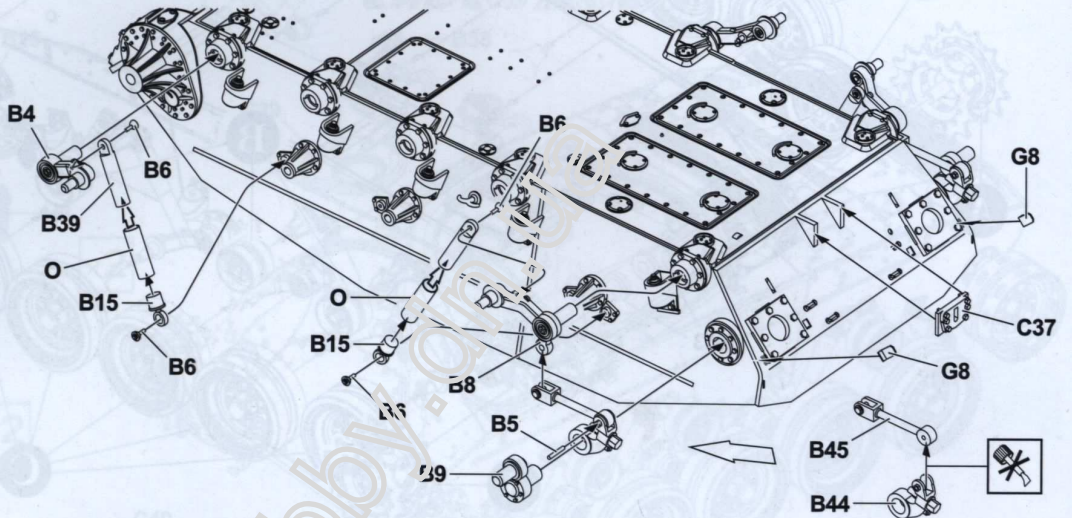
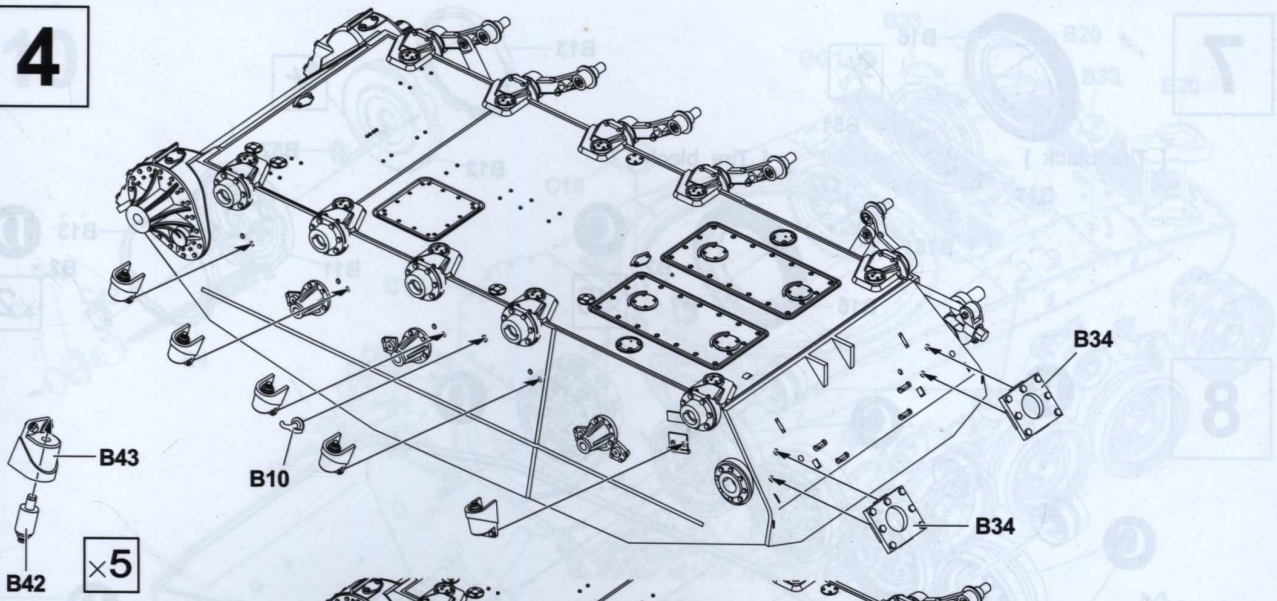

5

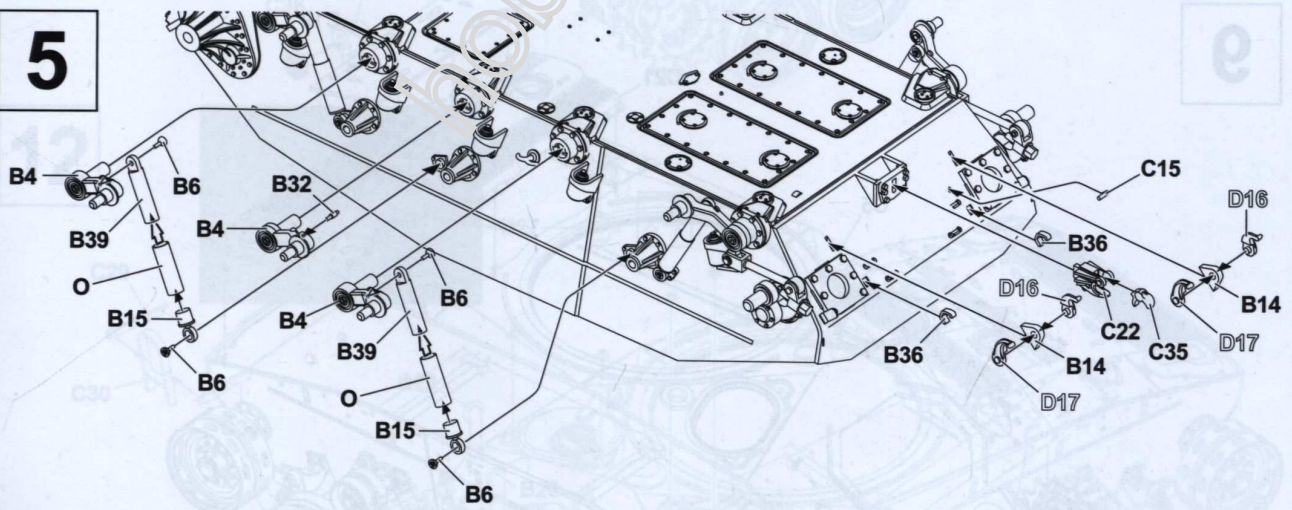

6

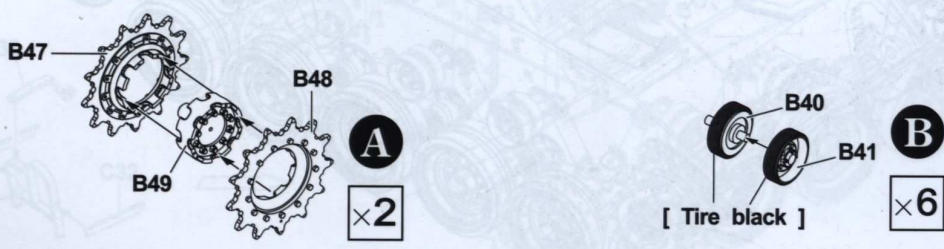

7

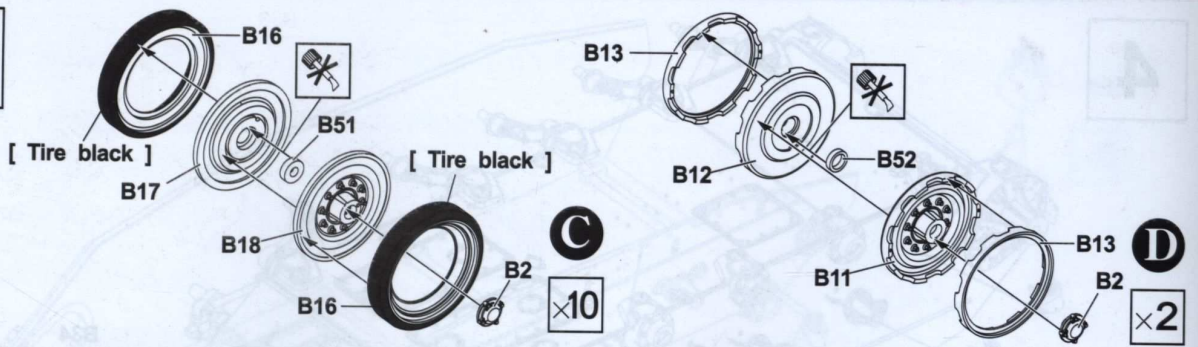

8

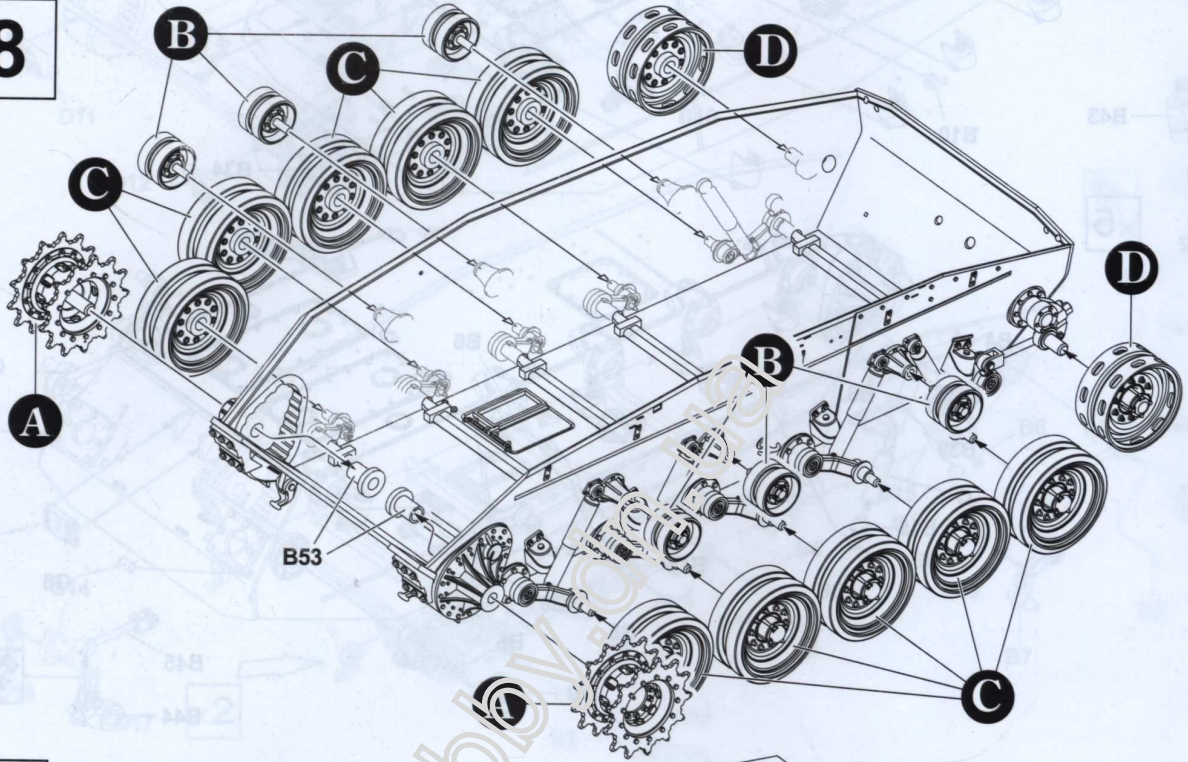

9

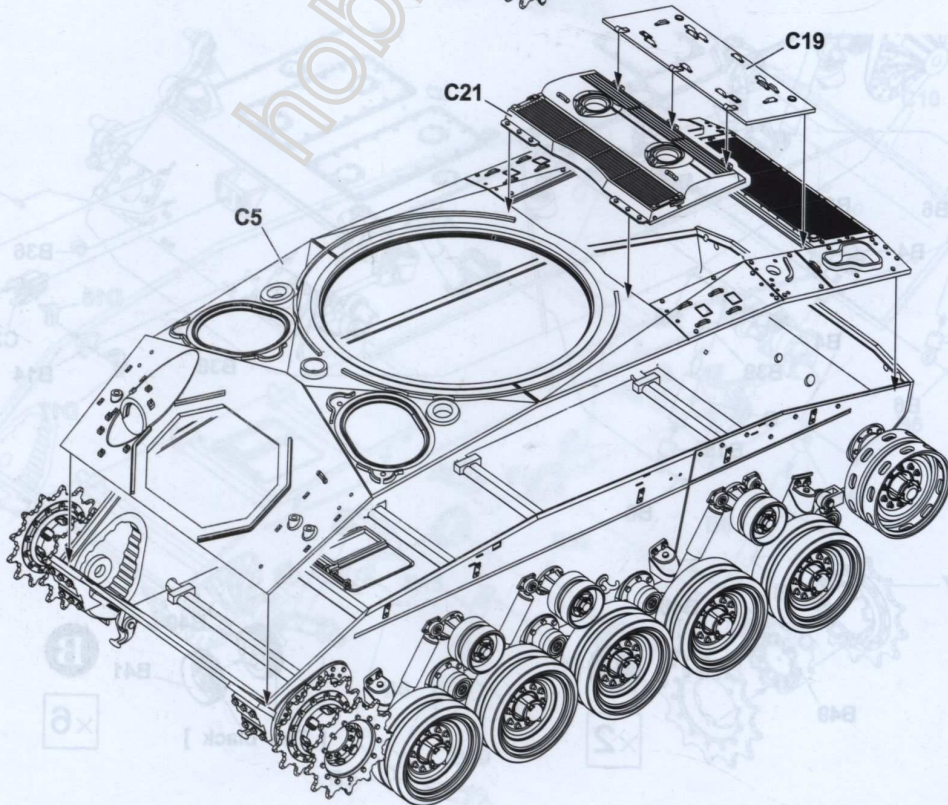

10

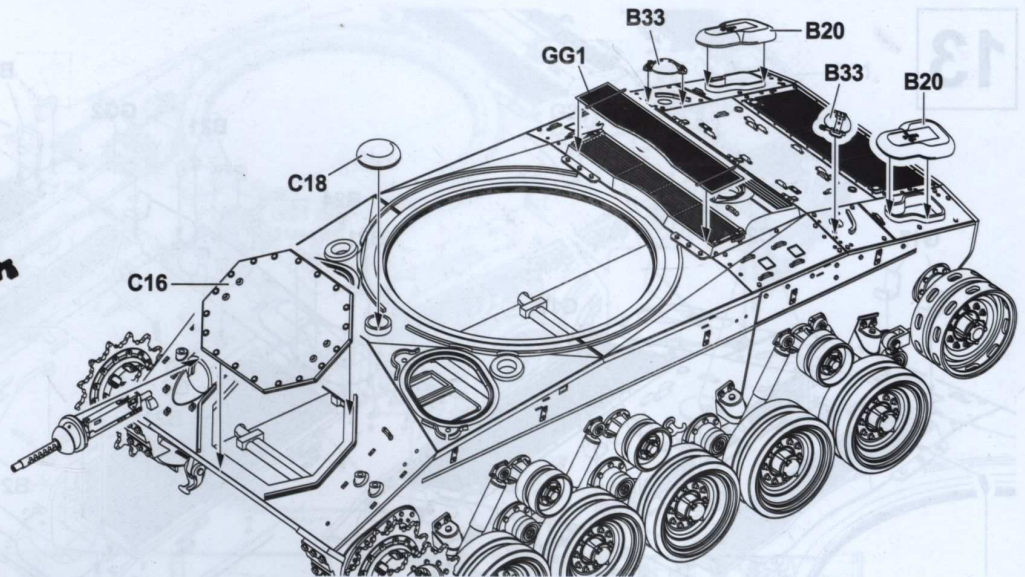
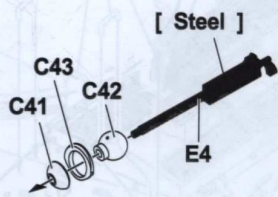

11

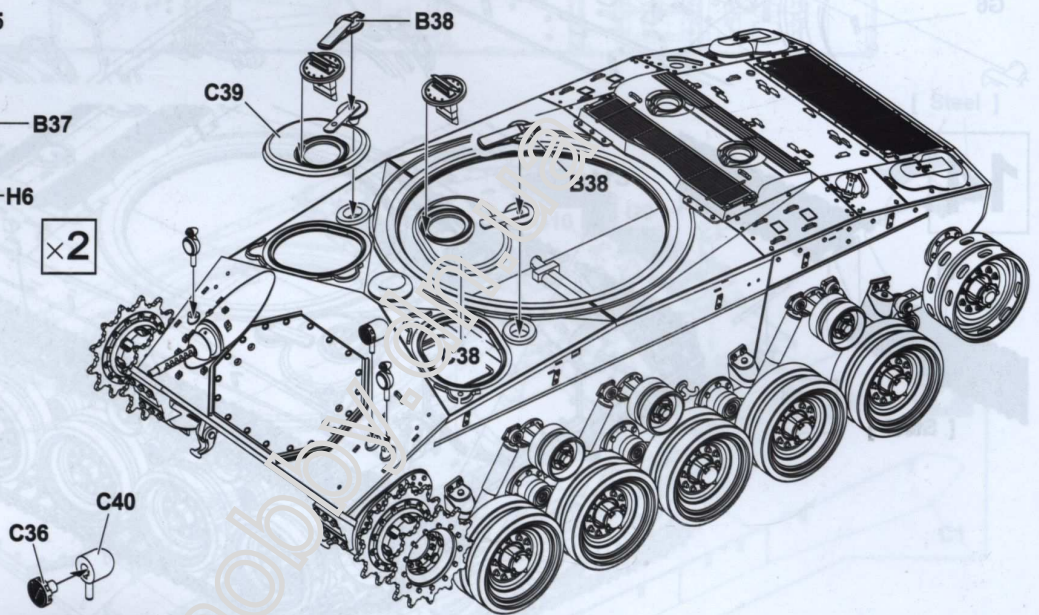
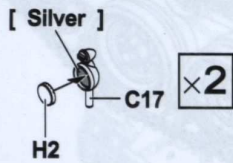
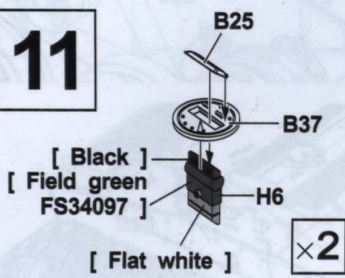

12

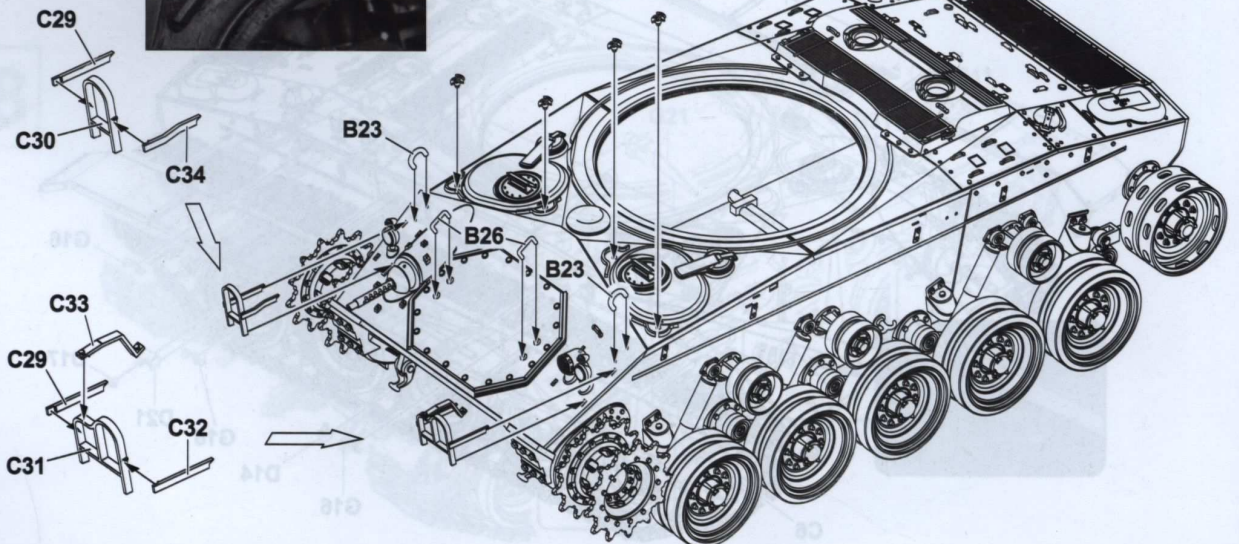
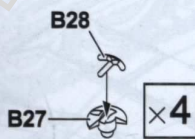

13

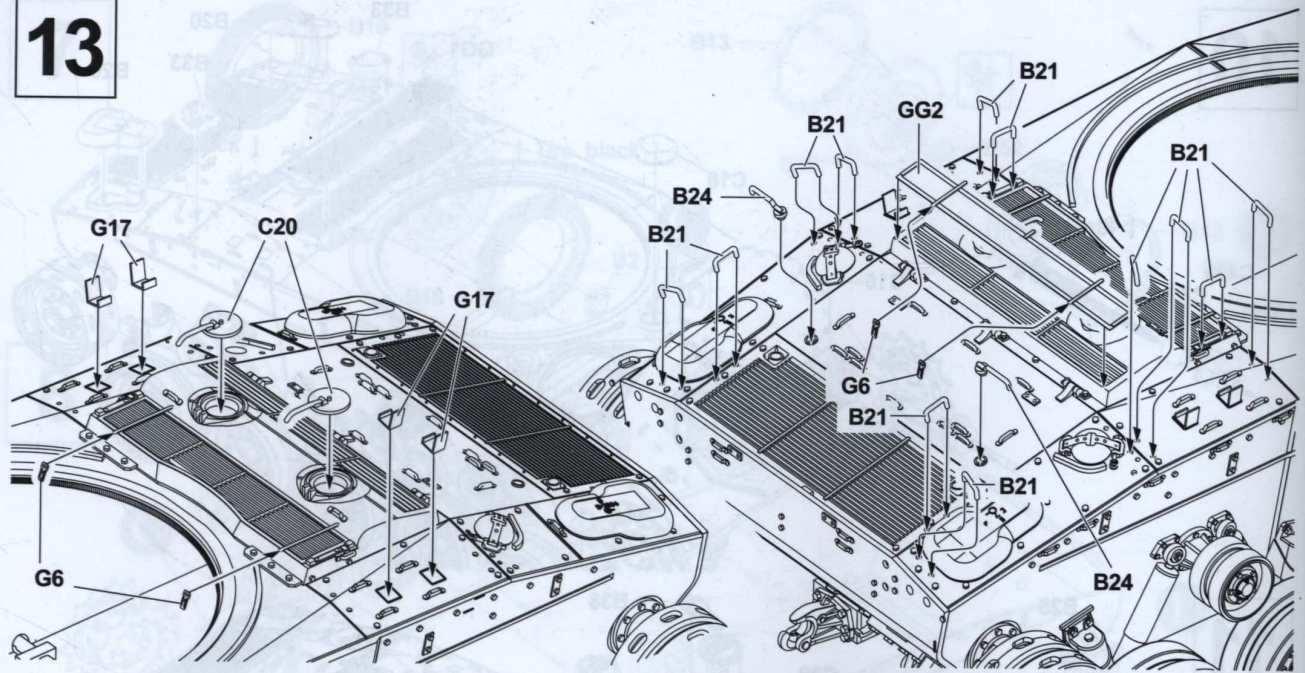

14

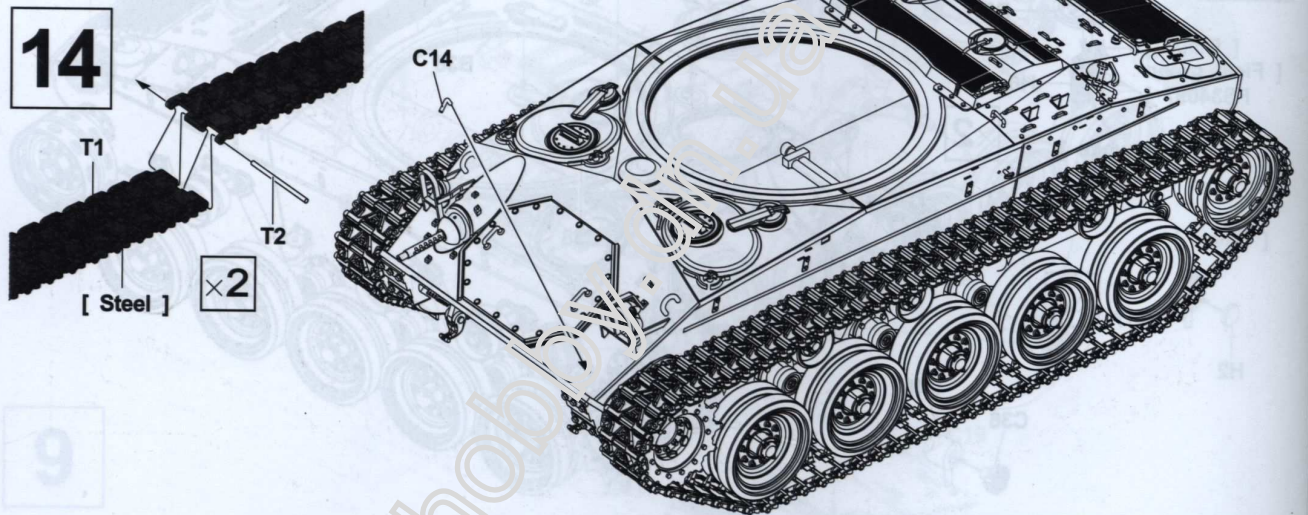

15

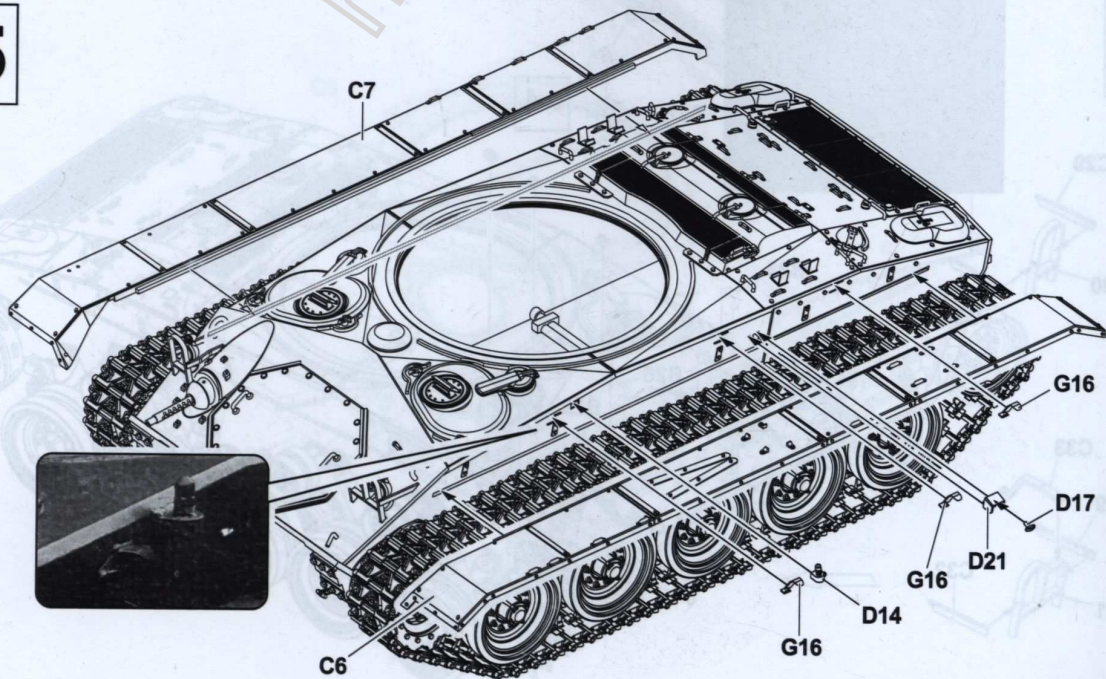

16

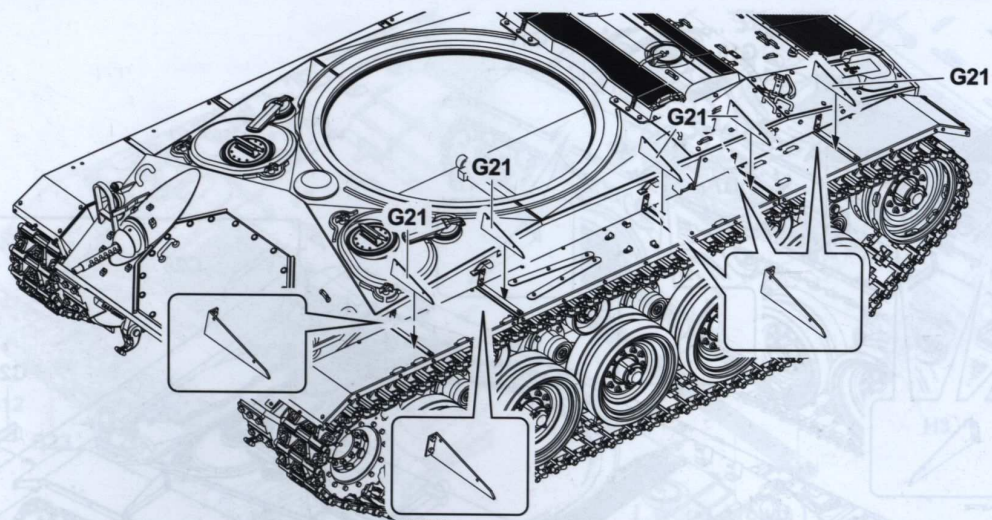

17

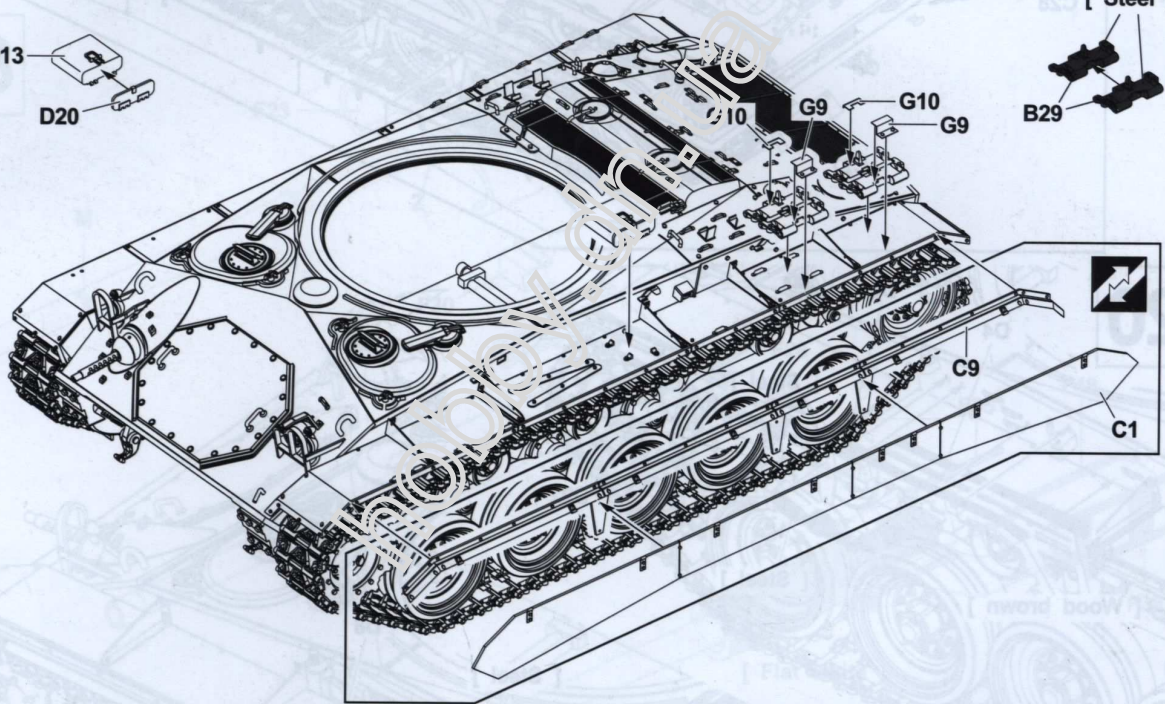
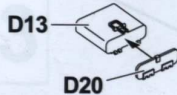
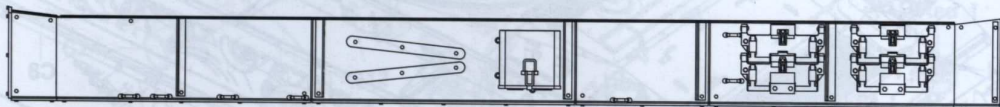

18

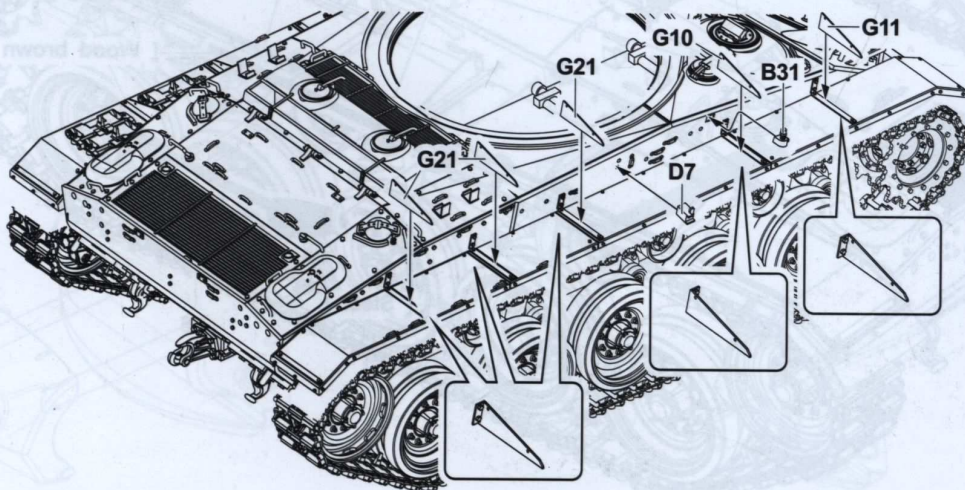

19

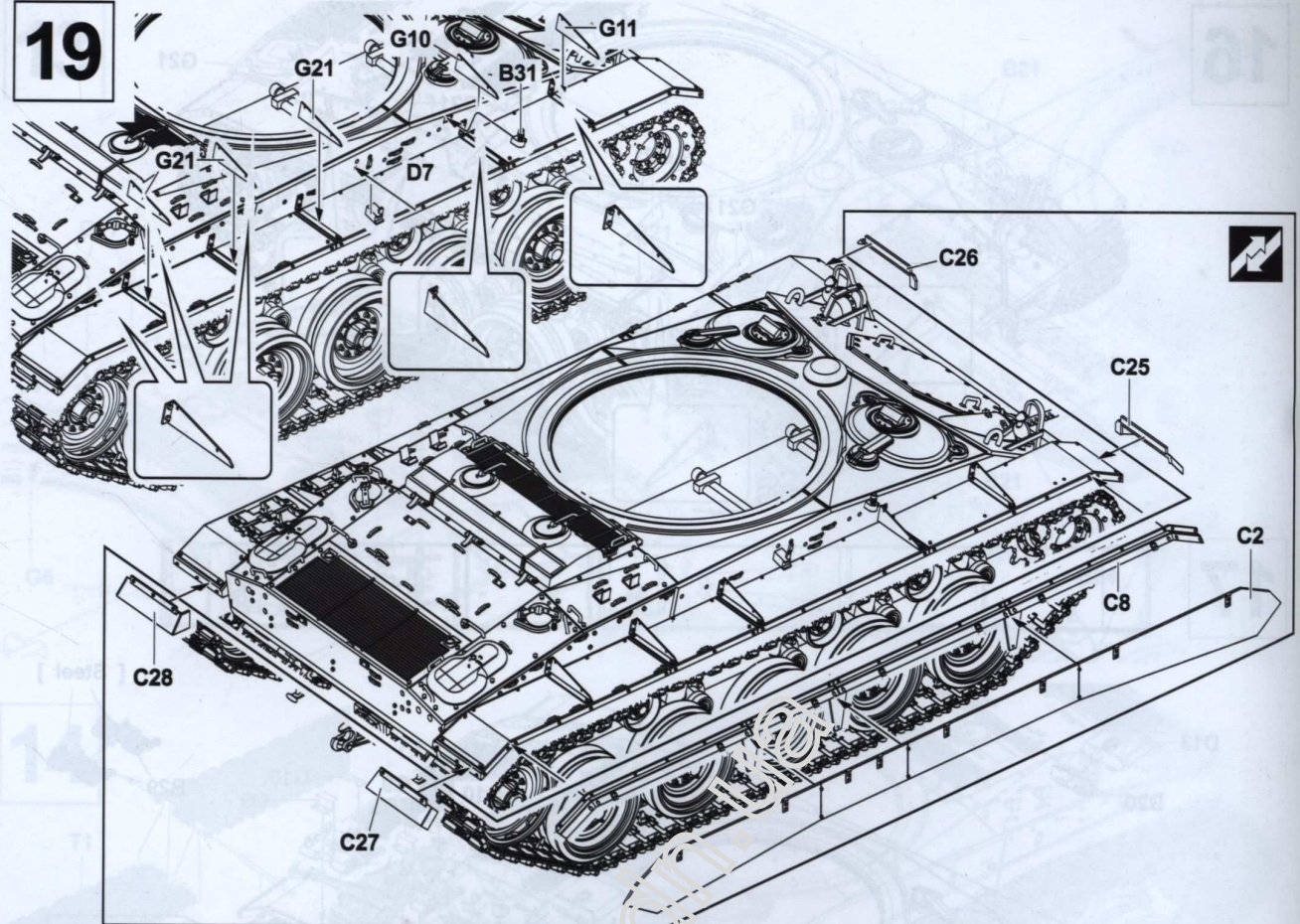

20

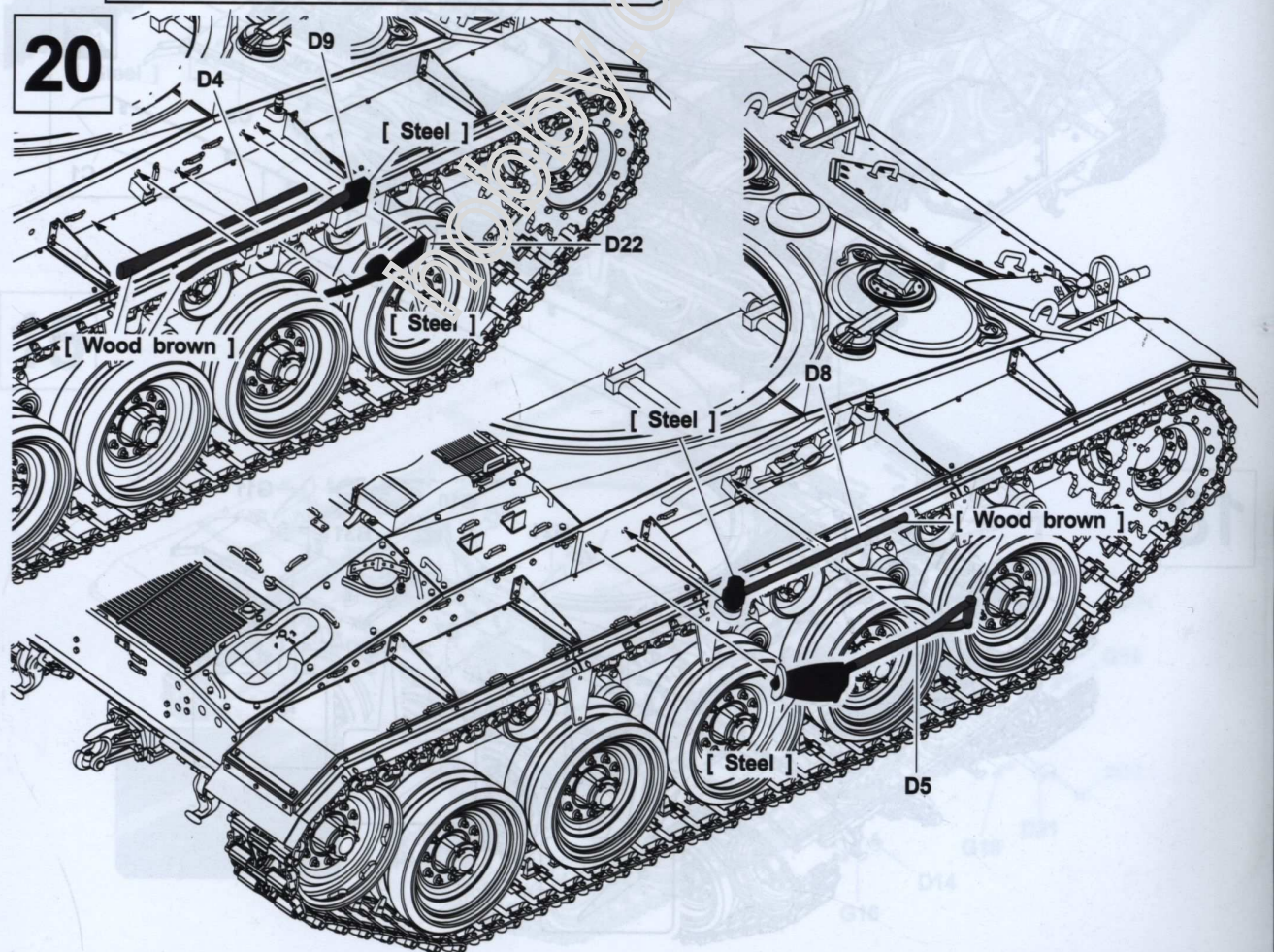

21

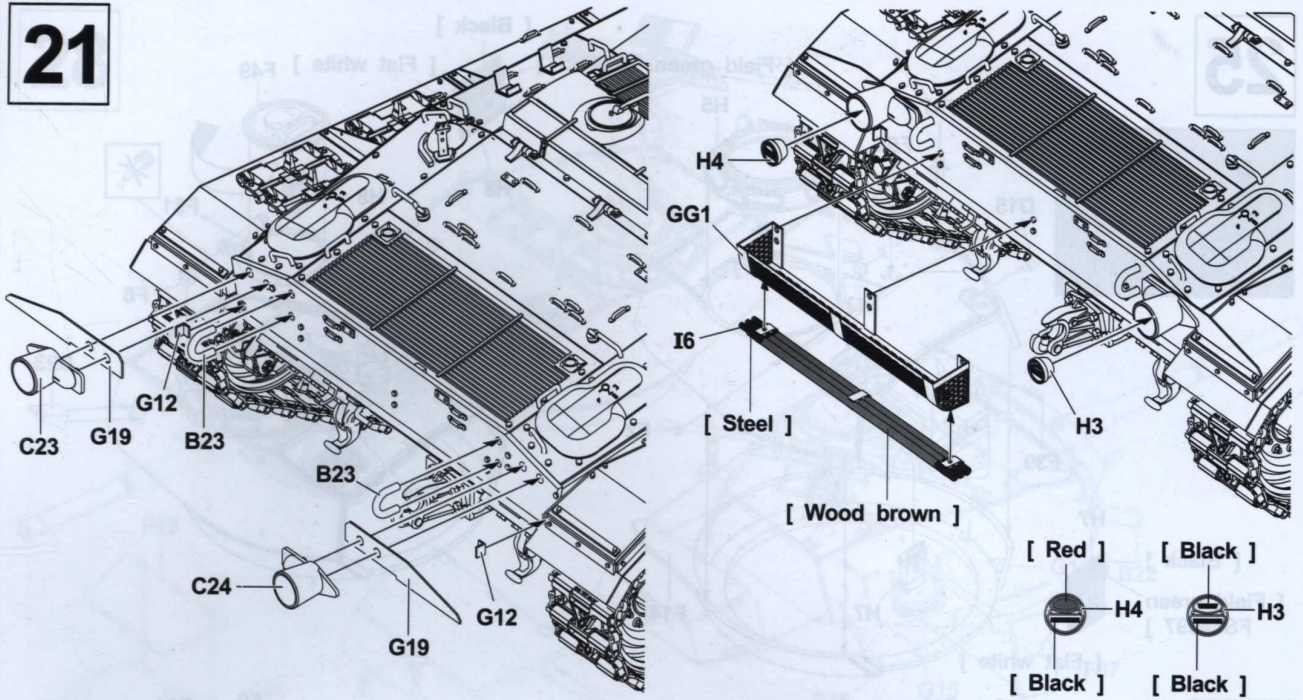

23

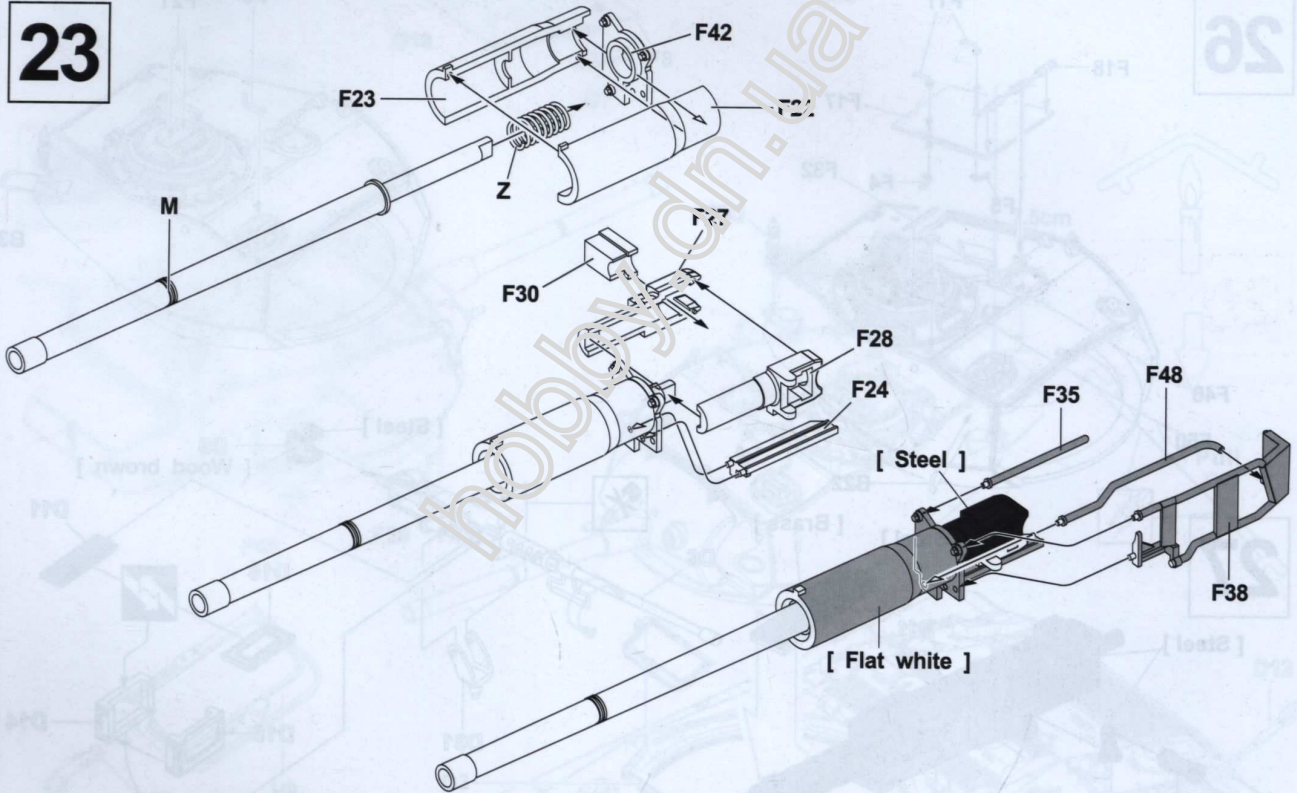

24

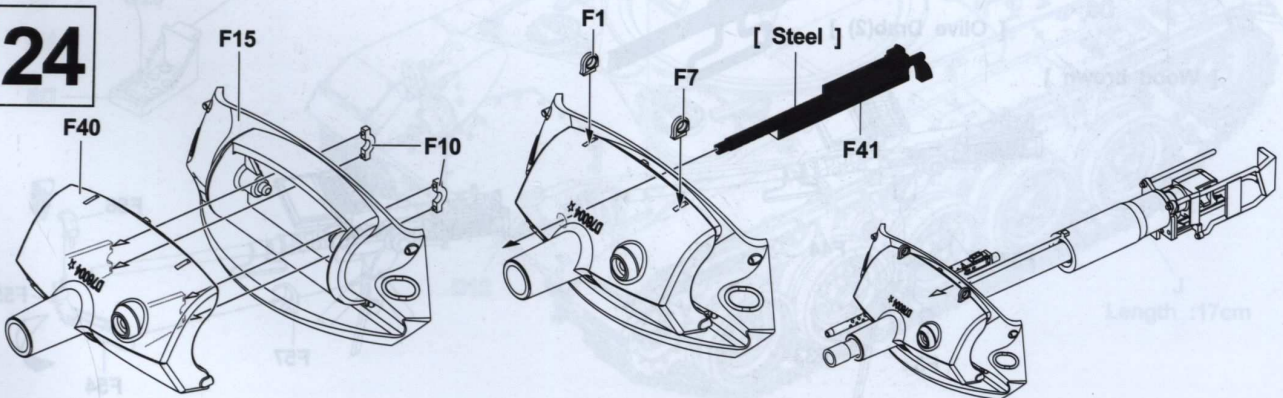

25

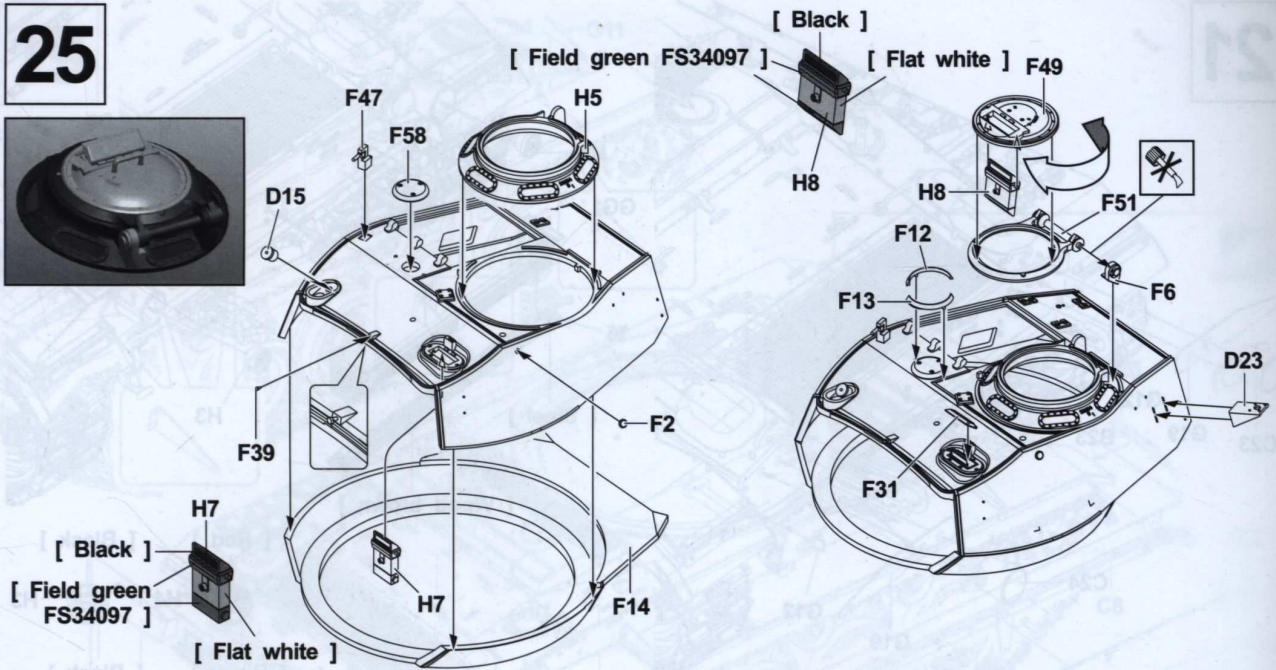

26

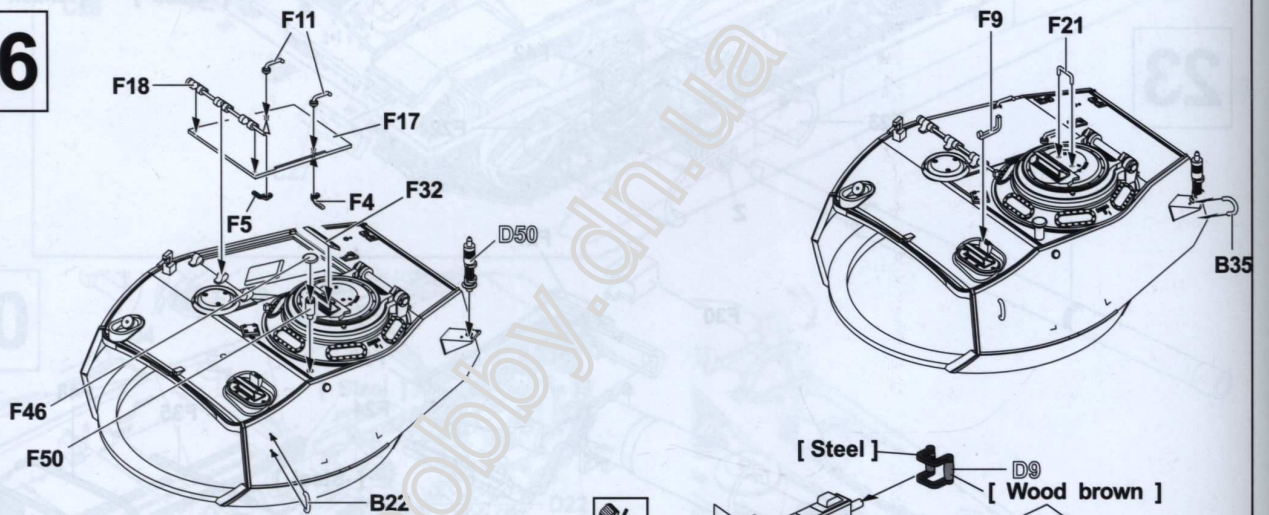

27

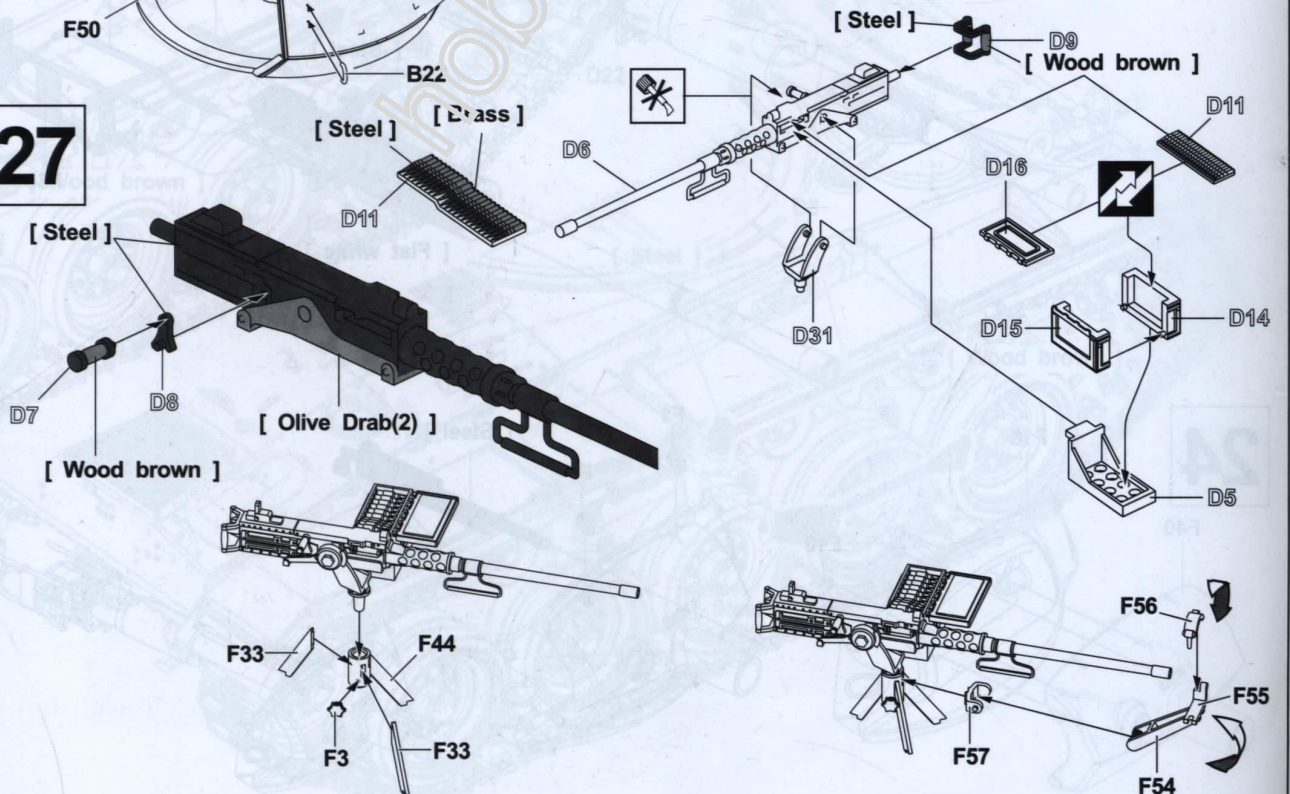

28

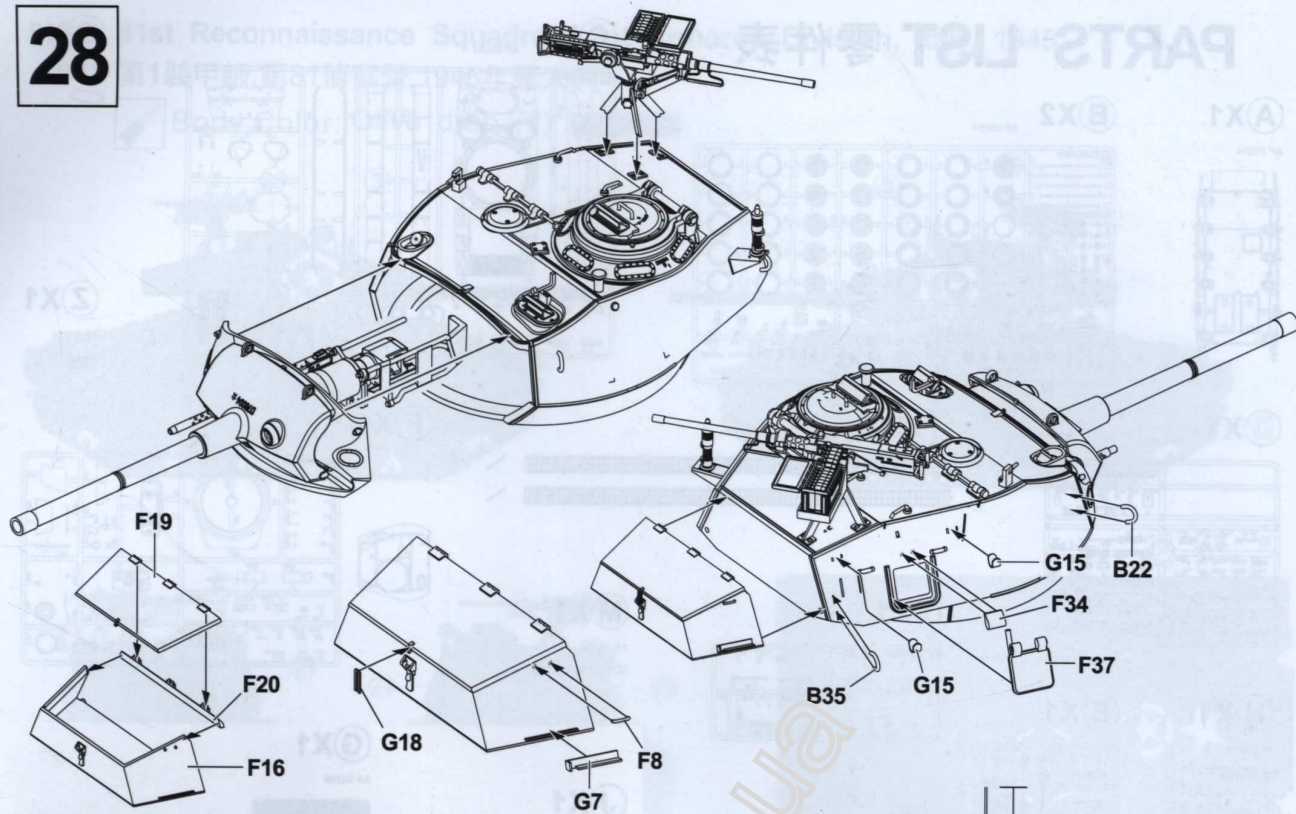

29

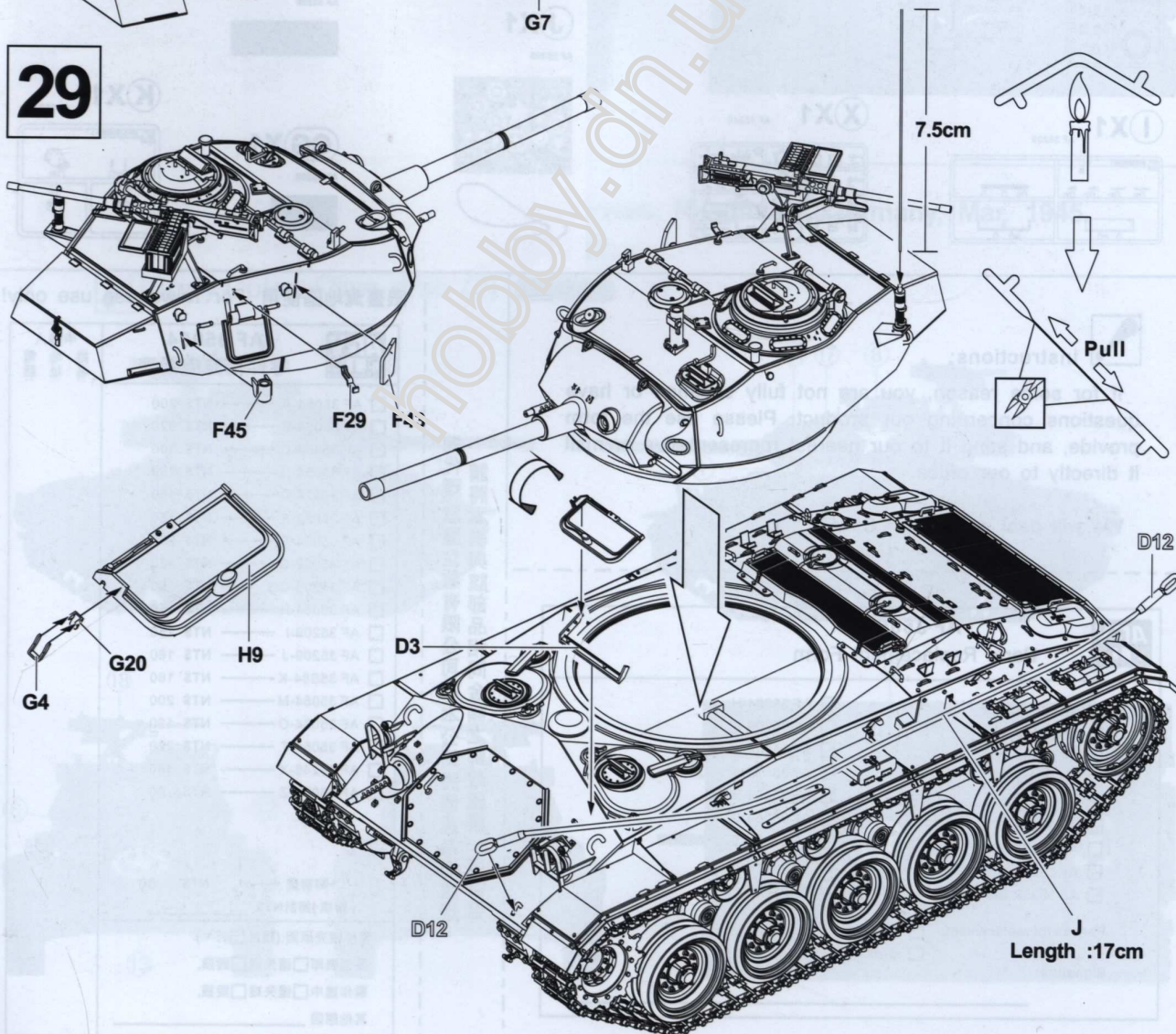

PARTS LIST 零件表

A X1

AF 35054

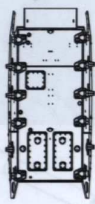

B X2

AF 35054

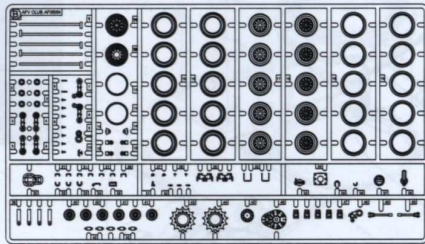

C X1

AF 35054

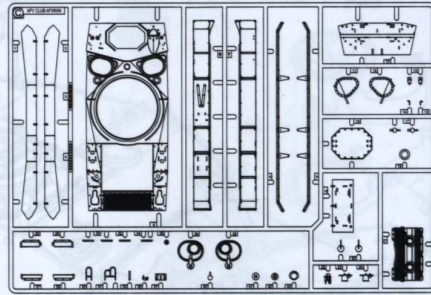

O X8

AF 35054



Z X1

AF 35054



D X1

AF 35024

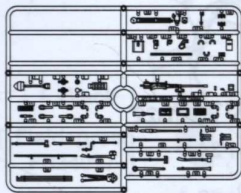

T X1

AF 35054

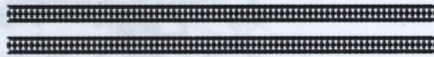

F X1

AF 35054

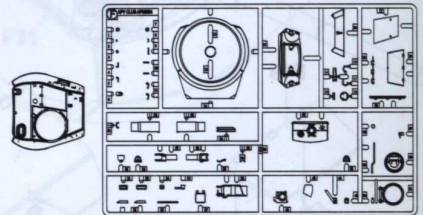

H X1

AF 35054

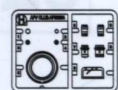

E X1

AF 35053

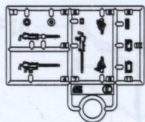

D X1

AF 35054

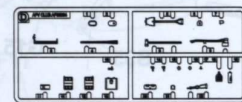

M X1

AF 35054

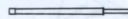

I X1

AF 35209

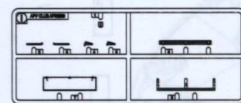

X X1

AF 35248

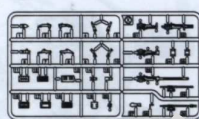

J X1

AF 35054

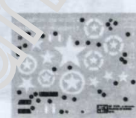

G X1

AF 35209



GG X1

AF 35054



Instructions:

If for some reason, you are not fully satisfied or have questions concerning our product, please use the form provided, and send it to our nearest representative or mail it directly to our office.

We will deal with that A.S.A.P.



AF 35054 Parts Replacement Form

- | | |
|--------------------------------------|-------------------------------------|
| <input type="checkbox"/> AF 35054-A | <input type="checkbox"/> AF 35054-H |
| <input type="checkbox"/> AF 35054-B | <input type="checkbox"/> AF 35209-I |
| <input type="checkbox"/> AF 35054-C | <input type="checkbox"/> AF 35209-J |
| <input type="checkbox"/> AF 35054-D | <input type="checkbox"/> AF 35S84-K |
| <input type="checkbox"/> AF 35024-D | <input type="checkbox"/> AF 35054-M |
| <input type="checkbox"/> AF 35053-E | <input type="checkbox"/> AF 35054-O |
| <input type="checkbox"/> AF 35054-F | <input type="checkbox"/> AF 35054-T |
| <input type="checkbox"/> AF 35209-G | <input type="checkbox"/> AF 35246-X |
| <input type="checkbox"/> AF 35209-GG | <input type="checkbox"/> AF 35054-Z |

Reason for replacement: Missing
 Broken

Signature: _____

限臺灣地區使用 For Taiwanese use only!



AF 35054 零件補充申請表

申請人
姓名 地址 電話

- | | |
|--------------------------------------|----------|
| <input type="checkbox"/> AF 35054-A | NT\$ 200 |
| <input type="checkbox"/> AF 35054-B | NT\$ 320 |
| <input type="checkbox"/> AF 35054-C | NT\$ 300 |
| <input type="checkbox"/> AF 35054-D | NT\$ 150 |
| <input type="checkbox"/> AF 35024-D | NT\$ 150 |
| <input type="checkbox"/> AF 35053-E | NT\$ 150 |
| <input type="checkbox"/> AF 35054-F | NT\$ 280 |
| <input type="checkbox"/> AF 35209-G | NT\$ 120 |
| <input type="checkbox"/> AF 35209-GG | NT\$ 80 |
| <input type="checkbox"/> AF 35054-H | NT\$ 150 |
| <input type="checkbox"/> AF 35209-I | NT\$ 150 |
| <input type="checkbox"/> AF 35209-J | NT\$ 160 |
| <input type="checkbox"/> AF 35S84-K | NT\$ 160 |
| <input type="checkbox"/> AF 35054-M | NT\$ 200 |
| <input type="checkbox"/> AF 35054-O | NT\$ 120 |
| <input type="checkbox"/> AF 35054-T | NT\$ 220 |
| <input type="checkbox"/> AF 35246-X | NT\$ 180 |
| <input type="checkbox"/> AF 35054-Z | NT\$ 60 |

+郵寄費 _____ NT\$ 80

(請填)總計NT\$ _____

零件補充原因:(請於 打)

原包裝即 遺失或 毀損,



製作途中 遺失或 毀損,

其他原因 _____

總代理: 戰鷹企業有限公司 收本公司將儘速為您處理。
請將本表與該部品相同金額之郵政匯票一同寄至

A 81st Reconnaissance Squadron, 1st Armored Division, Italy, 1945.

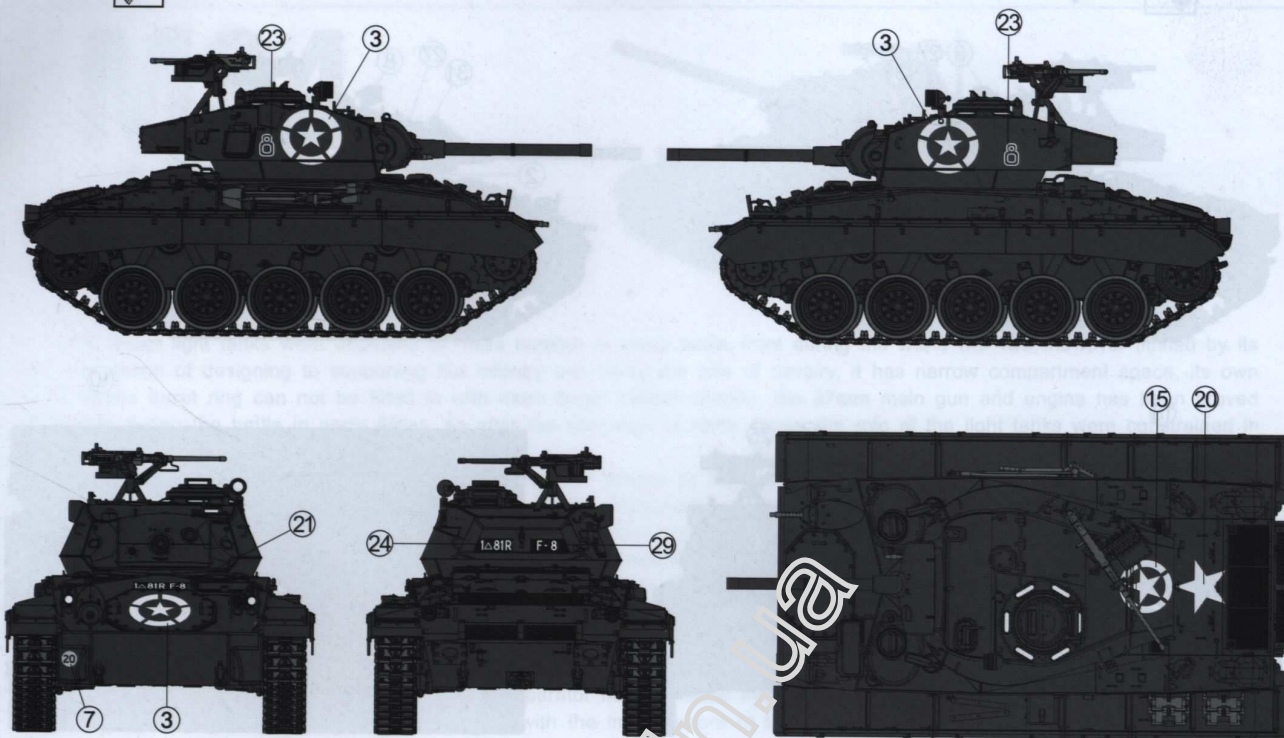

第1裝甲師,第81偵察營,1945年義大利。

 Body Color: Olive drab (2) 



B 36th Tank Battalion, 8th Armored Division, Rheinberg, Germany, Mar. 1945.

第8裝甲師,第36戰車營,1945年3月(德國萊茵)。

 Body Color: Olive drab (?) 

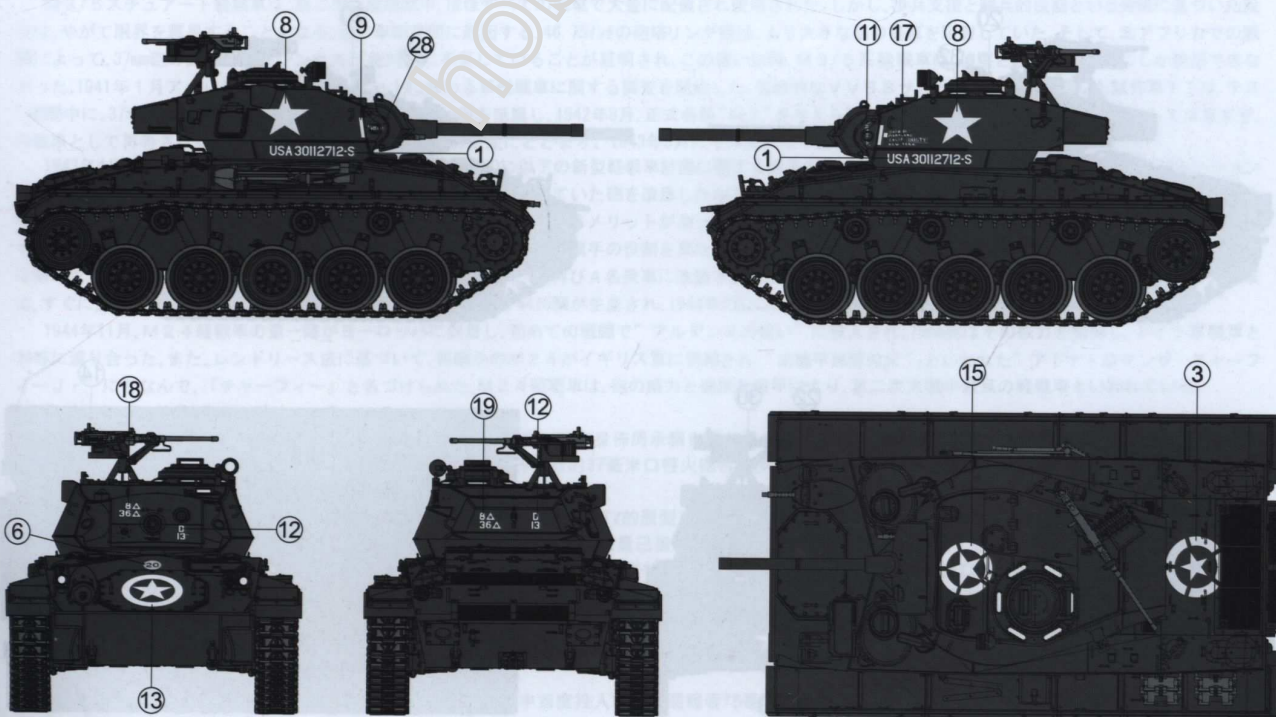

C 36th Tank Battalion, 8th Armored Division, Rheinberg, Germany, Mar. 1945.
 第8裝甲師,第36戰車營,1945年3月德國萊茵。

 Body Color: Olive drab (2) 

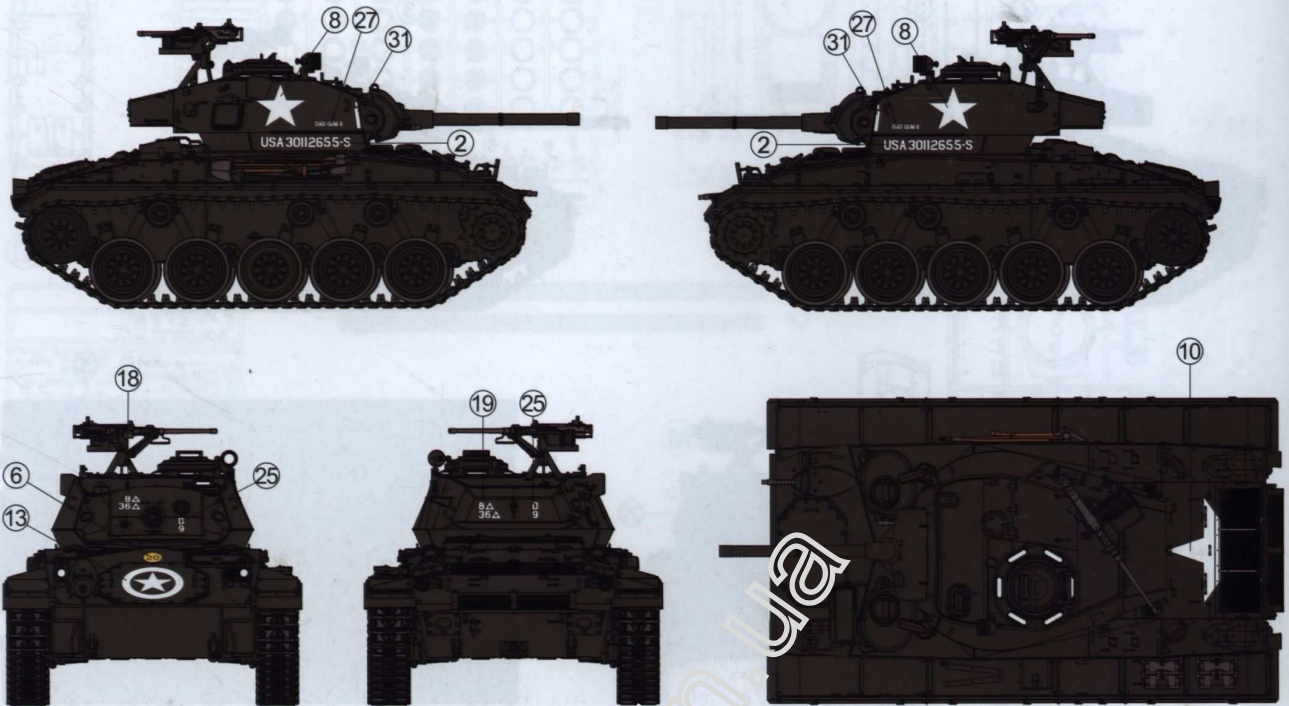

D 2nd Armored Cavalry Group, Germany Apr. 1945.
 第二裝甲騎兵群,德國,1945年4月。

 Body Color: Olive drab (2) 