



M1 40mm Bofors Anti-Aircraft Artillery

****SPECIAL THANKS: Imperial War Museum
Royal Artillery Museum**

Located in Sweden, Bofors originates from a hammering trip hammer mill founded 1646. The company expanded into weapons manufacture in late 19 century. Although Sweden itself did not involve in WWI, yet weapons manufacture subsidiary has become an important sector in Bofors Group.

The Swedish Navy commissioned Bofors to design a 20mm anti-aircraft cannon for ships in 1925. The Swedish Navy changed the specification to 40mm in 1928 because 20mm was considered to be insufficient. By 1930s, Krupp purchased a one-third share of Bofors. Krupp engineers started the process of updating the Bofors factories to use modern equipment and metallurgy. Acceptance trials for 40 mm aka M/32 were completed in 1932, and Dutch Navy became the first buyer in 1934. Bofors also developed a truck-based m/34 on a towable carriage. The cannon was commonly known as Bofors 40mm L/60.

Giving Bofors 40mm L/60's performance has been well recognized, by 1939 it has been adopted or produced under license in no less than 18 countries. The Bureau of Ordnance of U.S. Navy bought six sets of Bofors 40 mm gun from the British Army in 1940 for tests, aiming to fill the gap of current weapon system's different calibers.

In a demonstration that the US Army Ordnance Department also attended, it was found that the Bofors gun performed better than the M1 37mm anti-aircraft gun, which just entered services. US Army therefore showed high interests in this gun. Yet negotiations did not go smoothly due to complicated political reasons as the Europe was already in wars at that time. Under license, Chrysler started to build Bofors 40mm guns, yet Chrysler engineers were forced to make radical changes to the Swedish design in order to minimize production problems, such as hand works in production lines, to improve mass production rate.

The Bofors 40mm guns entered Army and Navy services in May 1941, and in the follow month, production authorization was formally obtained from the British-but only for US armored forces. By end of 1943, a total of 28892 Bofors 40mm gun was produced. A great number of Army 40mm Automatic Gun, M1 Anti-Aircraft saw services in the Pacific campaigns. In Europe, due to less threat from the Luftwaffe, part of anti-aircraft were used on ground targets.

鉄工所を起源とするボフォース社が、スウェーデンに設立されたのは、1646年のことであり、19世紀後期に兵器の製造を開始した。第一次世界大戦が勃発すると、スウェーデンは参戦しなかったものの、兵器の需要は拡大し、それまで副次的な位置づけであった兵器製造部門は、一転してボフォースグループのなかで、重要な地位を占めるに至ったのである。

1925年、スウェーデン海軍は艦艇搭載用の防空火器として口径20mmの対空砲の設計を依頼した。1928年になると20mm砲の威力に不足を感じたスウェーデン海軍は、口径の仕様設定を40mmに変更した。1930年代に入り、軍備制限下にあったドイツのクルップ社が、ボフォース社の株式の1/3を取得、クルップの技術者は近代的な設備や冶金技術を活用するために、ボフォースの工場の更新に着手した。1932年、40mm aka M/32は試用の結果、合格、1934年にオランダ海軍が最初の購入者となった。ボフォースは、車輛牽引・移動式の地上用タイプ M/34も開発し、これはボフォース40mm L/60として知られている。

ボフォース40mm対空砲L/60が高い評価を得ていたことは、1939年までに18以上の国が採用、ライセンス生産していた事実がなによりの証拠であり、それは連合軍のみならず枢軸軍でも使用されていたのである。1940年、米海軍兵器局は現状の対空装備の中間を埋める火砲の必要を感じ、英陸軍から6門のボフォース40mm機関砲を購入、テストを行った。

米陸軍兵器局も加わったテストにおいて、ボフォース40mm機関砲は、当時配備が始まったばかりのM137mm対空砲を上回る性能をみせた。そのため、米陸軍はボフォース砲に高い関心を示したが、当時ヨーロッパは既に戦争に突入しており、政治的理由によって購入交渉はなかなか進まなかった。そのため、クライスラー社がライセンス生産を行うこととなったが、その際にクライスラーの技術者は、基になったスウェーデン版の設計に抜本的な変更を加え、手仕事に頼る部分などの生産工程上の問題を排除し、大量生産に適したものに置き換えることで、生産性を飛躍的に向上させることに成功したのだった。

ボフォース40mm機関砲は、1941年5月に米陸海軍に配備が始まり、翌月米軍が使用するものに限定してボフォース社から正式に製造権が与えられたのであった。1943年末までに、総計28892門のボフォース40mm砲が生産され、大量の陸軍40mm機関砲およびM1対空砲が、太平洋戦線に投入されたのだった。ヨーロッパでは、ドイツ空軍の脅威が減少したため、一部の対空砲は、対地攻撃に使用されたりしたのだった。



SCALE 1:35 AF 35163

Bofors Anti-Aircraft Artillery



REGAL TANKS, London, W.C.2
Great Britain

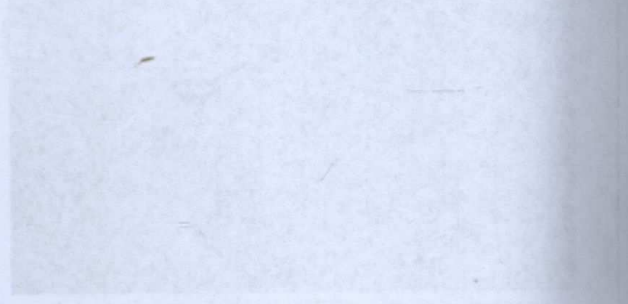

The Bofors anti-aircraft gun is a 40 mm calibre gun which was developed in Sweden in 1928. It was designed by Carl Gustaf Palm and his colleagues at the Bofors works in Borås. The gun is a light anti-aircraft gun and is used for the defence of ships and coastal areas. It is a very effective gun and has been used in many wars. The Bofors gun is a very popular gun among collectors and is a very valuable gun. It is a very good gun and is a very good investment. It is a very good gun and is a very good investment. It is a very good gun and is a very good investment.

The Bofors anti-aircraft gun is a very good gun and is a very good investment. It is a very good gun and is a very good investment. It is a very good gun and is a very good investment. It is a very good gun and is a very good investment. It is a very good gun and is a very good investment. It is a very good gun and is a very good investment. It is a very good gun and is a very good investment. It is a very good gun and is a very good investment. It is a very good gun and is a very good investment. It is a very good gun and is a very good investment.

The Bofors anti-aircraft gun is a very good gun and is a very good investment. It is a very good gun and is a very good investment. It is a very good gun and is a very good investment. It is a very good gun and is a very good investment. It is a very good gun and is a very good investment. It is a very good gun and is a very good investment. It is a very good gun and is a very good investment. It is a very good gun and is a very good investment. It is a very good gun and is a very good investment. It is a very good gun and is a very good investment.

The Bofors anti-aircraft gun is a very good gun and is a very good investment. It is a very good gun and is a very good investment. It is a very good gun and is a very good investment. It is a very good gun and is a very good investment. It is a very good gun and is a very good investment. It is a very good gun and is a very good investment. It is a very good gun and is a very good investment. It is a very good gun and is a very good investment. It is a very good gun and is a very good investment. It is a very good gun and is a very good investment.

The Bofors anti-aircraft gun is a very good gun and is a very good investment. It is a very good gun and is a very good investment. It is a very good gun and is a very good investment. It is a very good gun and is a very good investment. It is a very good gun and is a very good investment. It is a very good gun and is a very good investment. It is a very good gun and is a very good investment. It is a very good gun and is a very good investment. It is a very good gun and is a very good investment. It is a very good gun and is a very good investment.

hobby.dn.ua

8

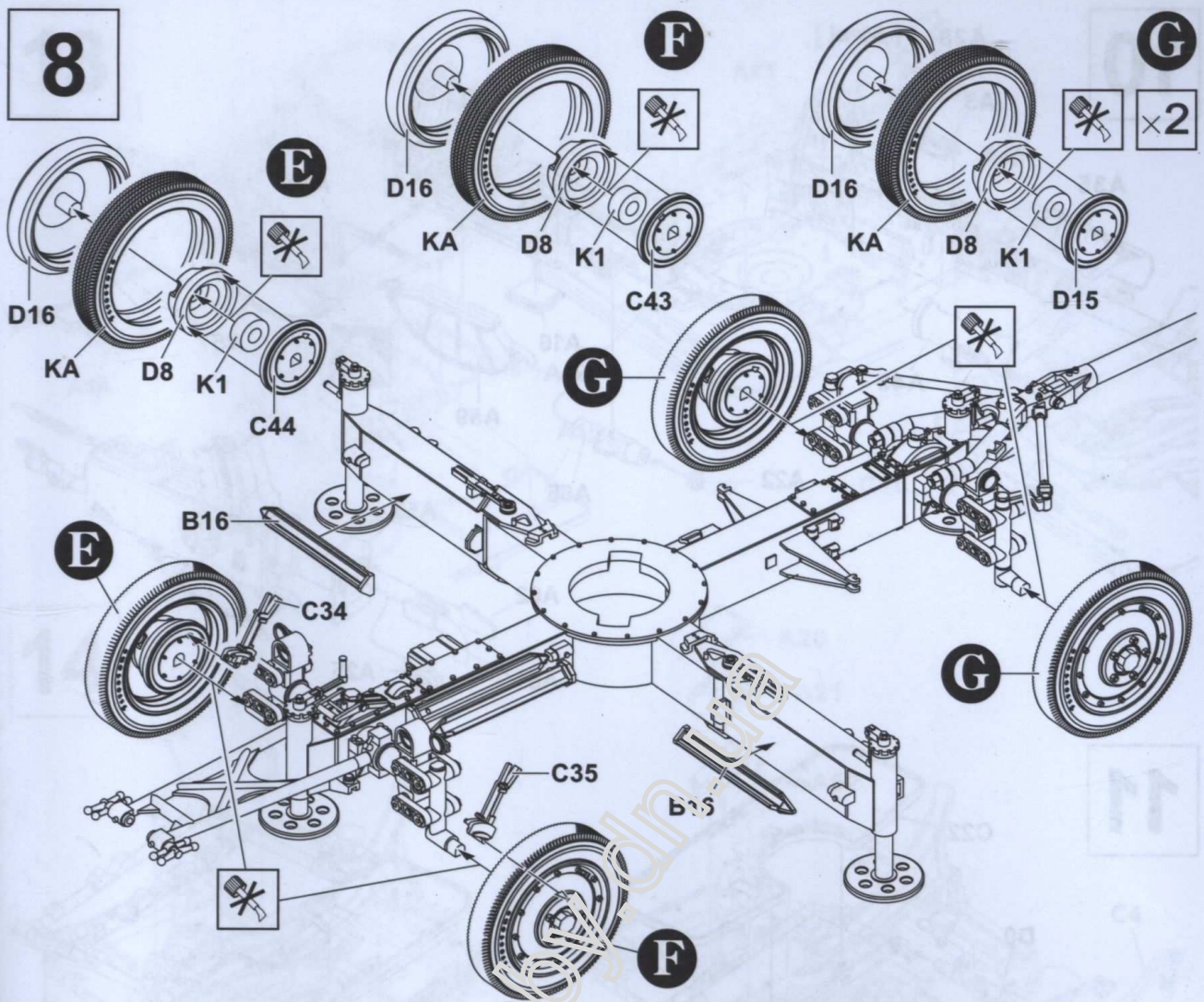

9

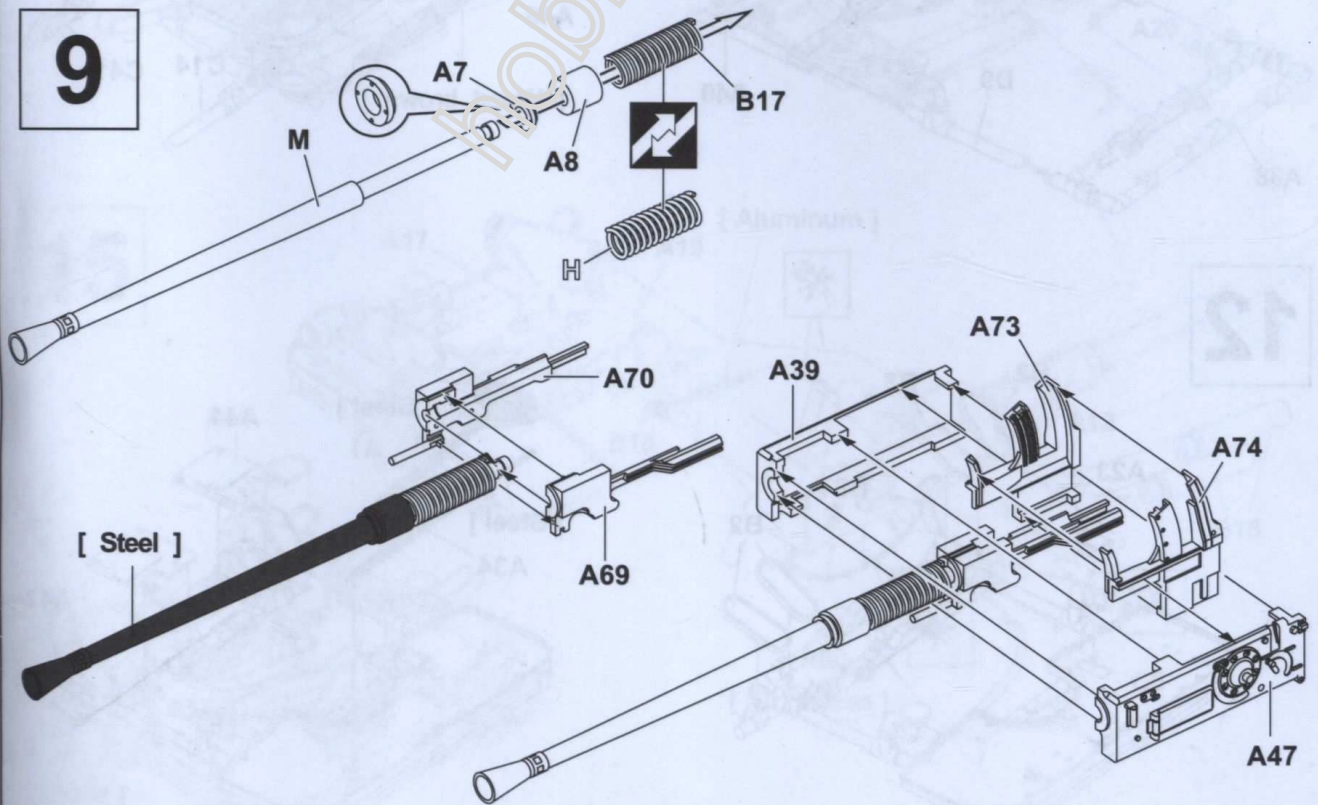

10

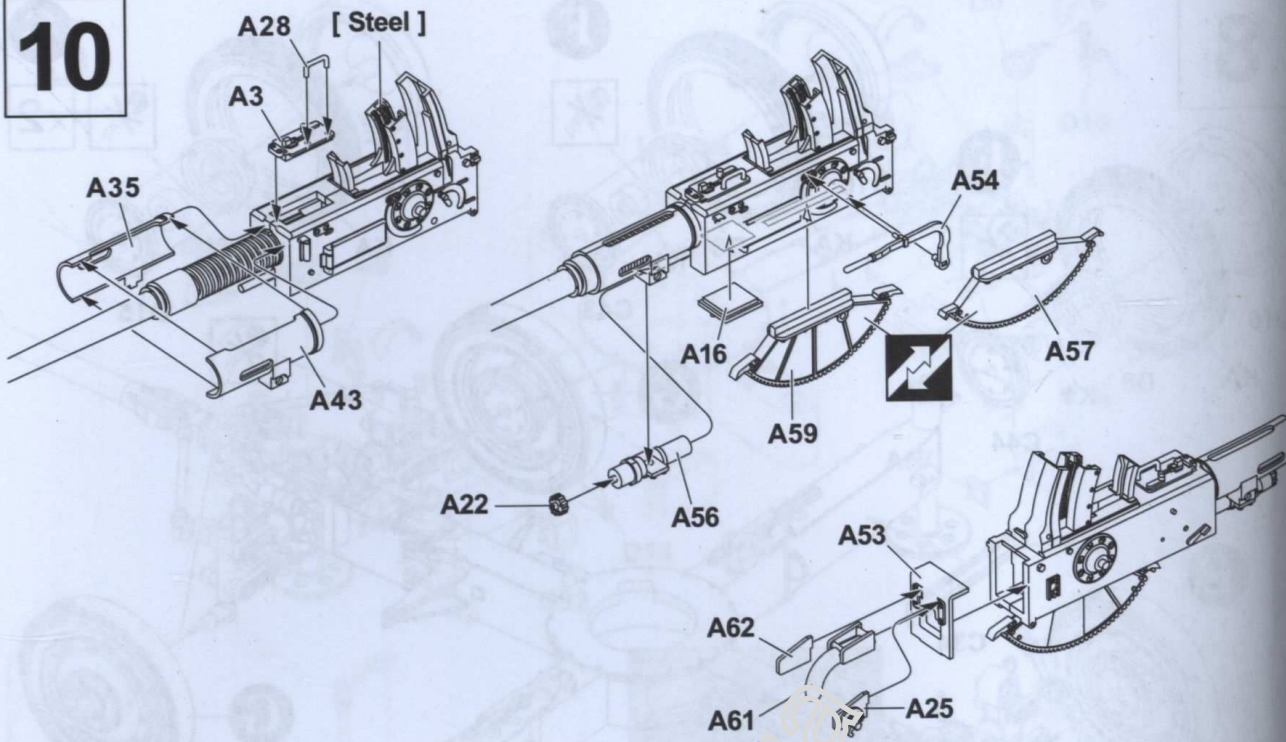

11

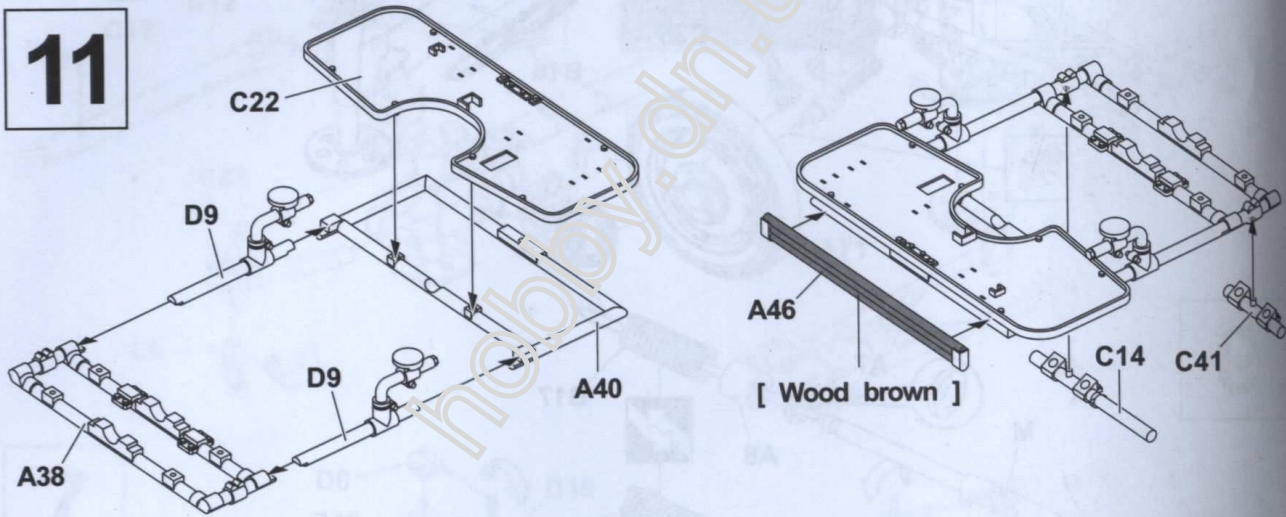

12

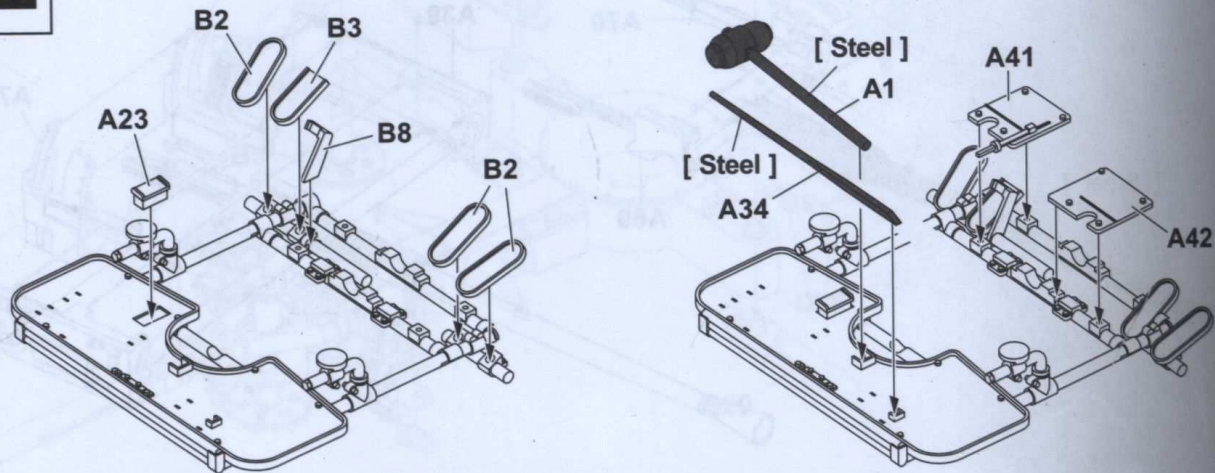

13

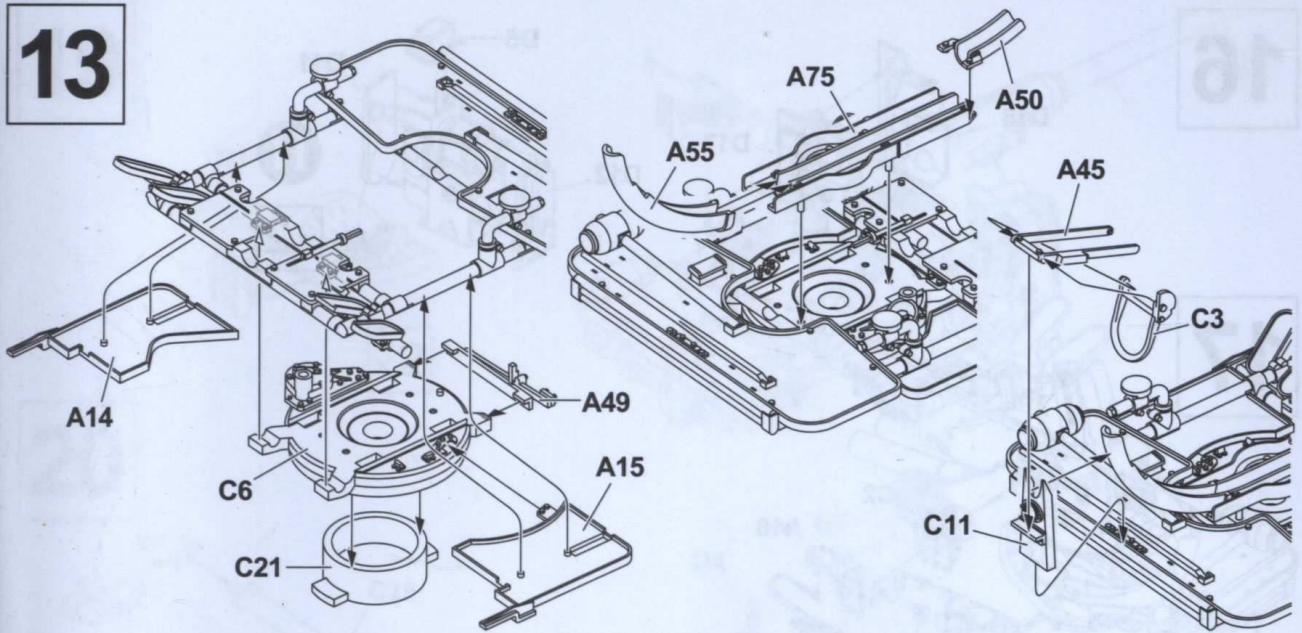

14

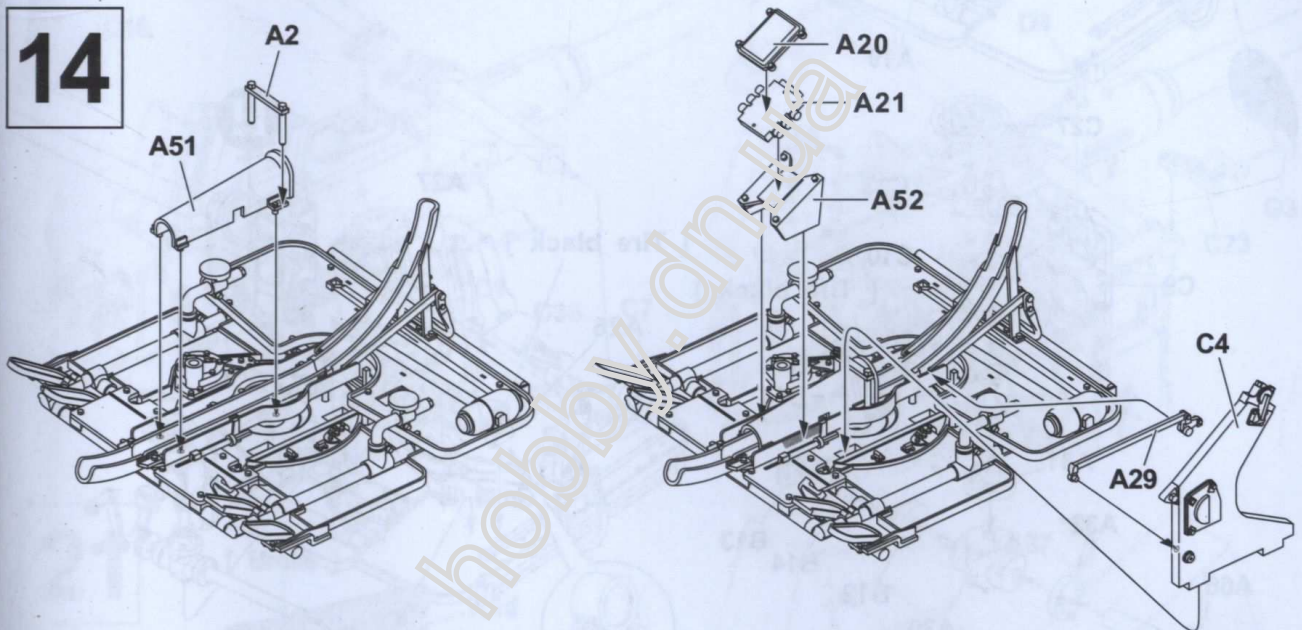

15

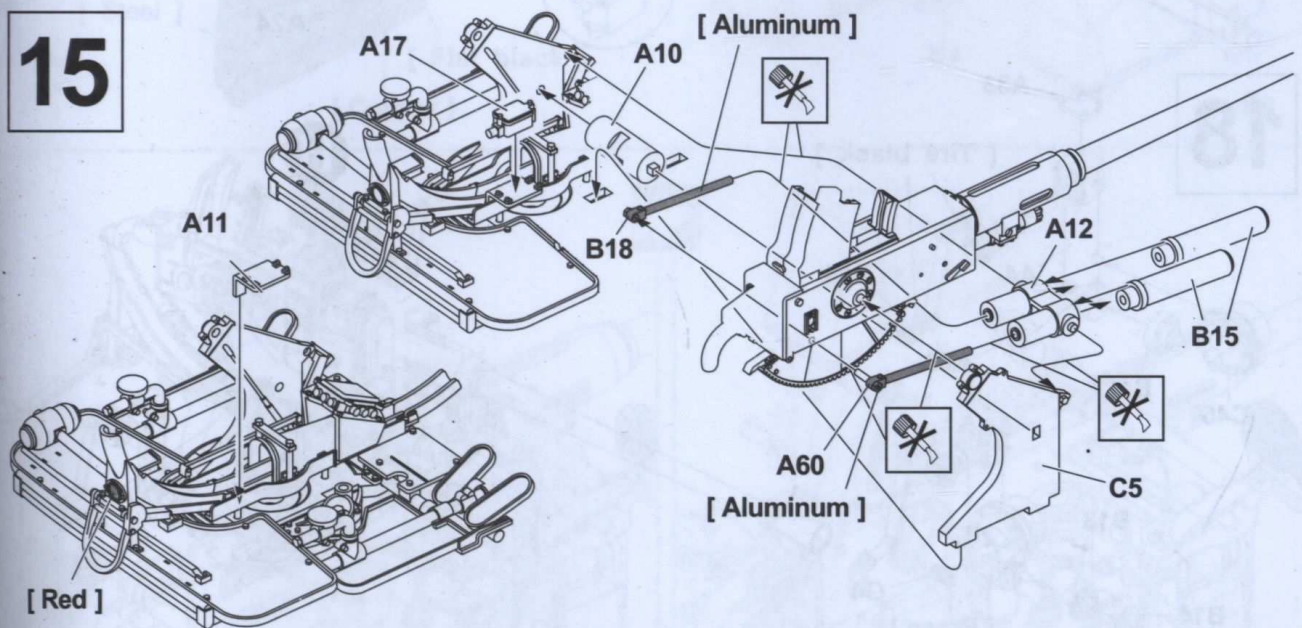

16

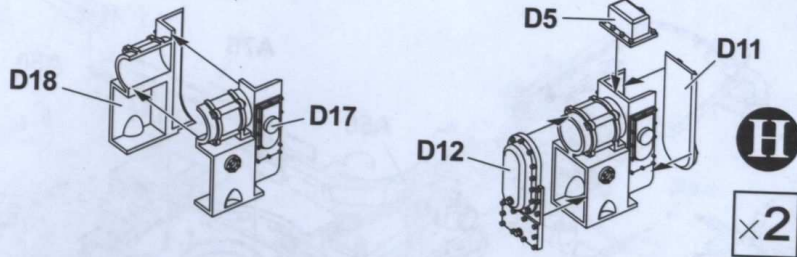

17

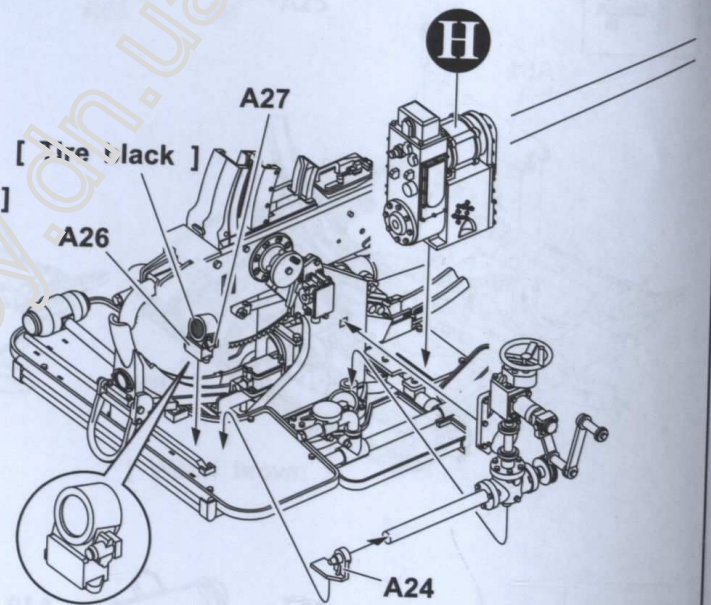
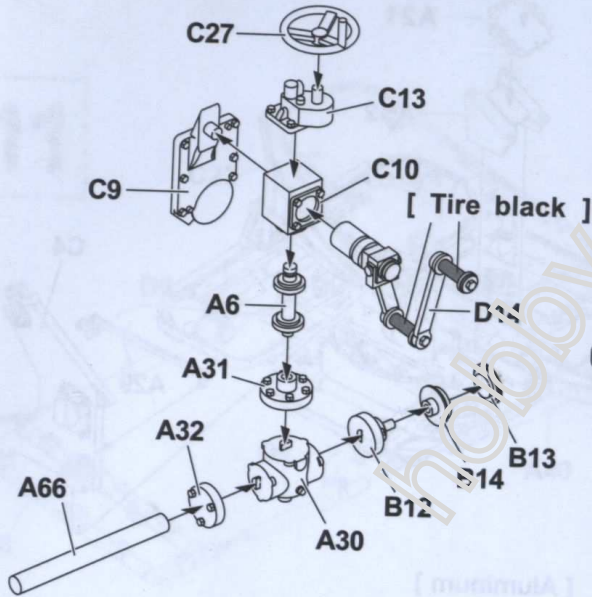
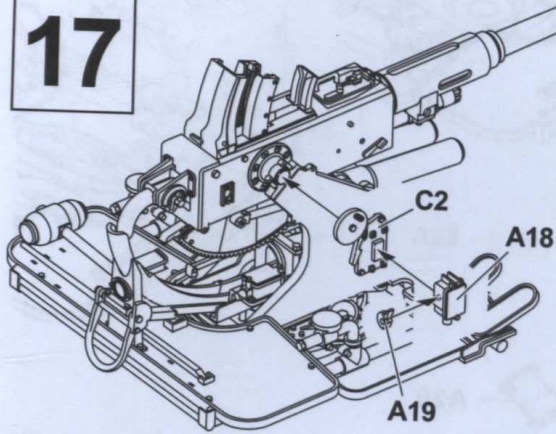

18

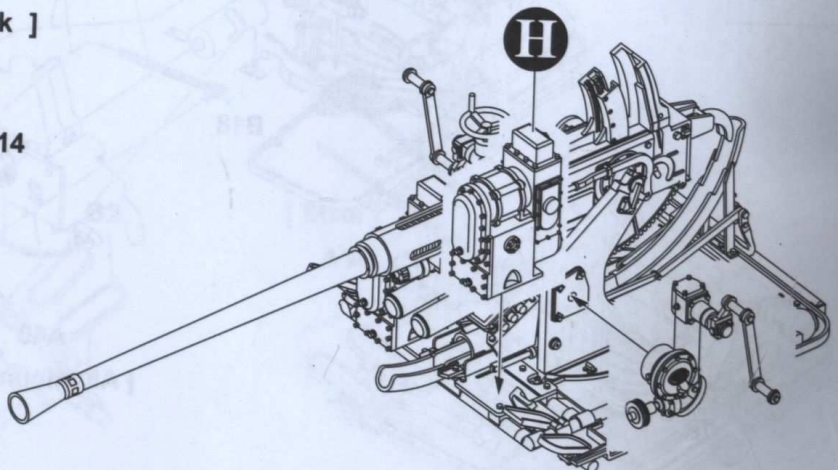
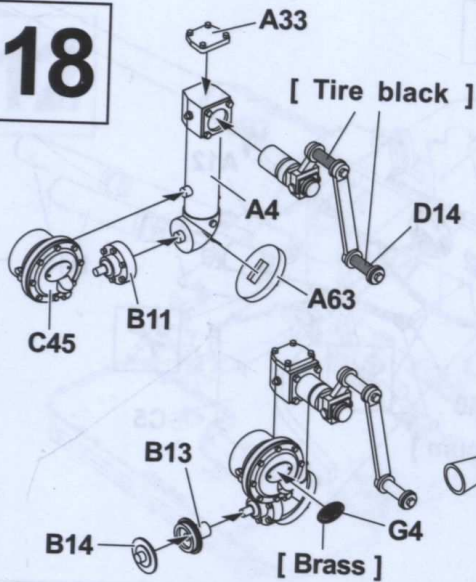

19

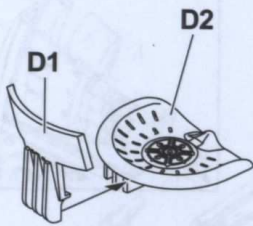

×2

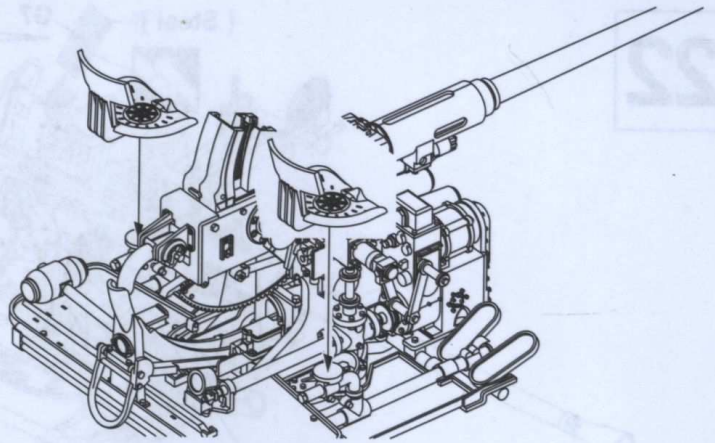

20

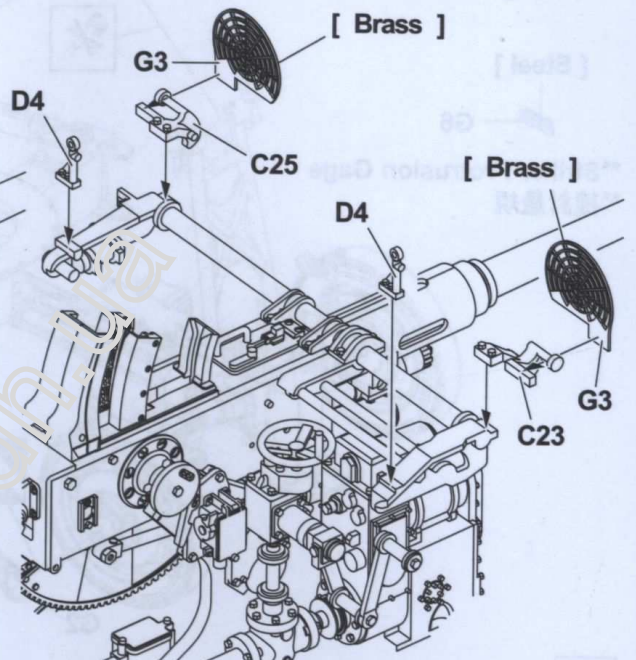
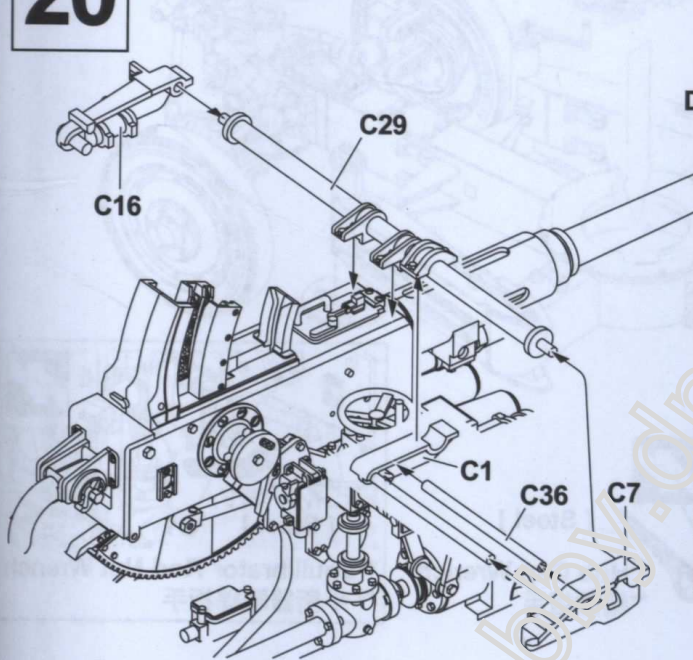

21

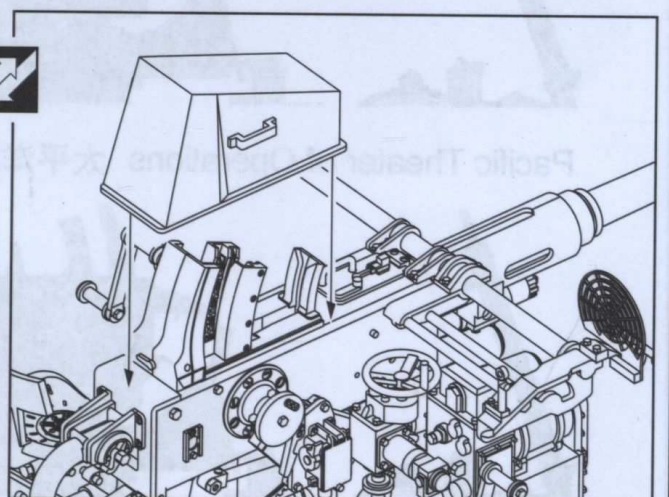
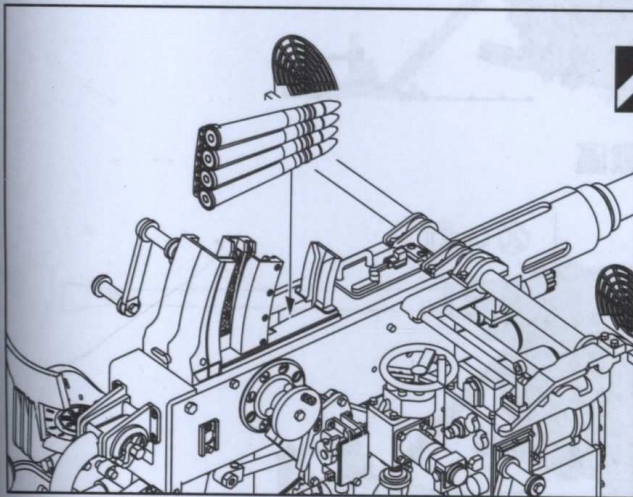
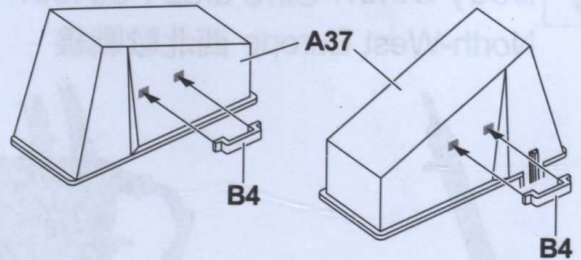
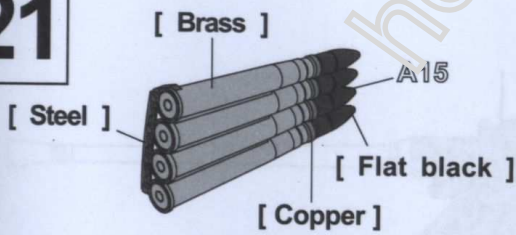

22

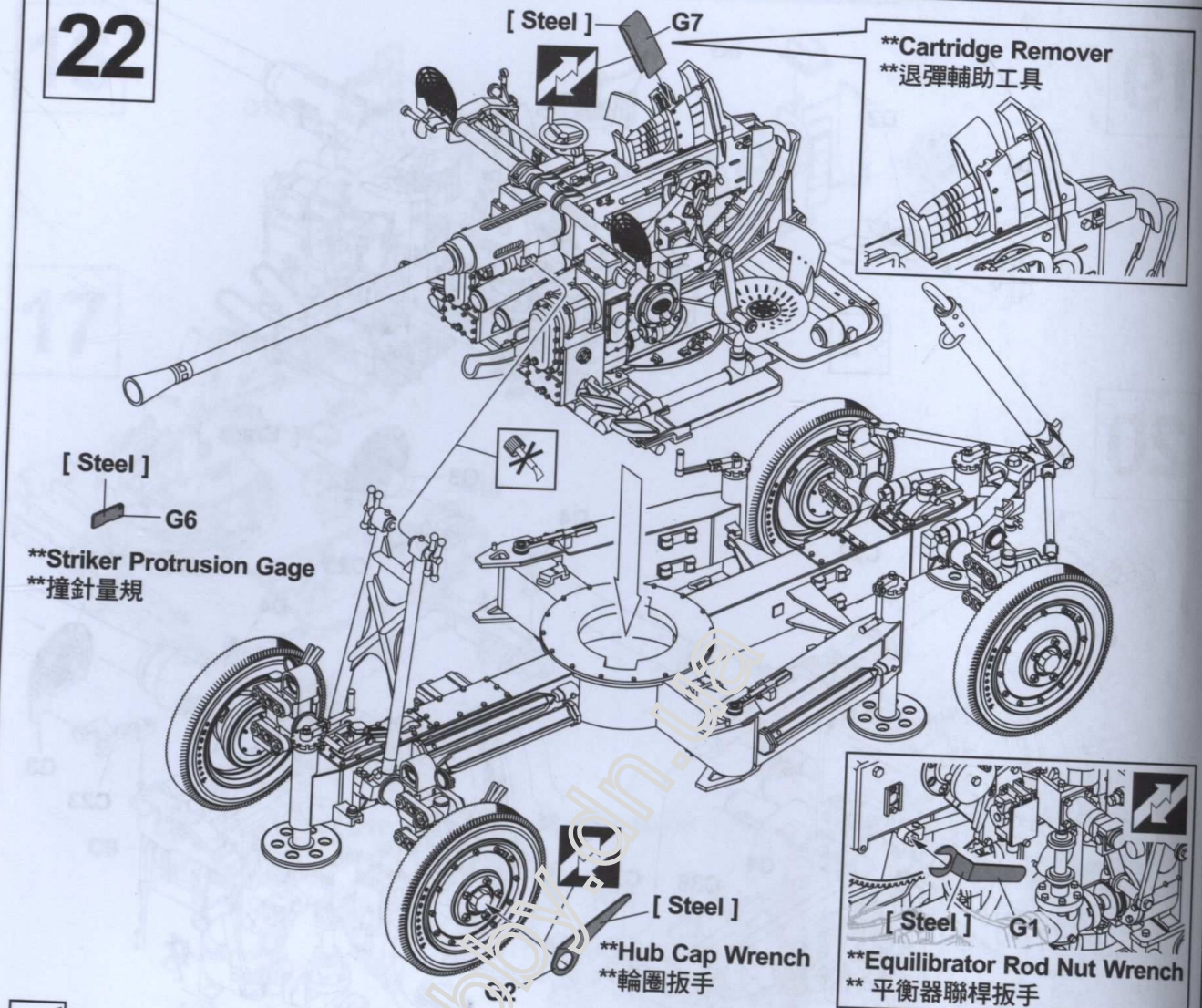

 Body Color: Olive drab FS34087
North-West Europe 西北歐戰線

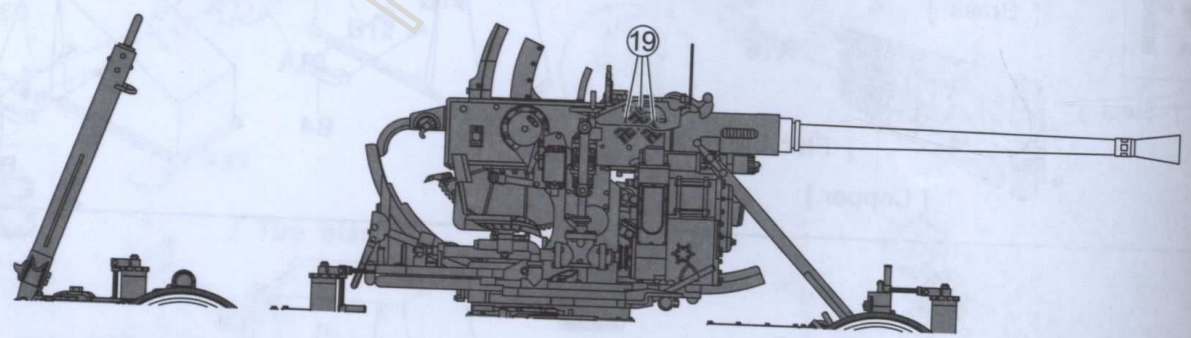

Pacific Theater of Operations 太平洋戰區

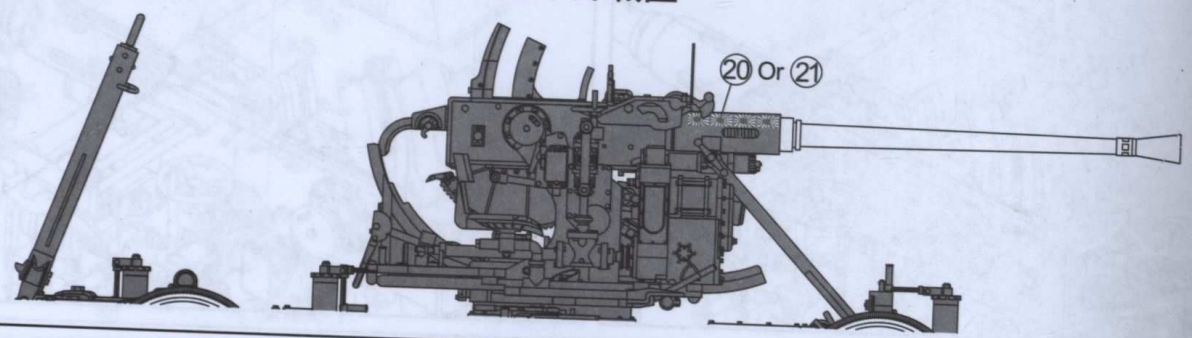

PARTS LIST 零件表

A X1 AF 35163

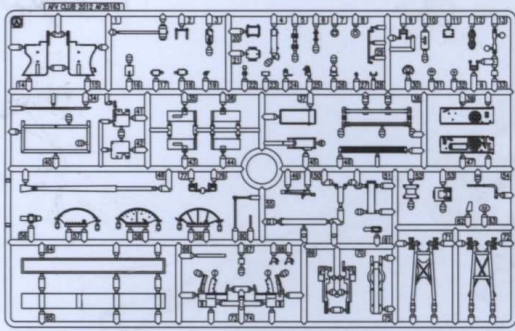

B X1 AF 35163

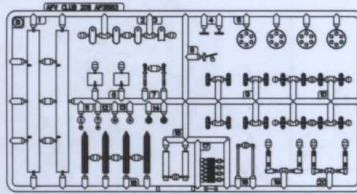

M X1 AF 35163



H X1 AF 35042



E X1 AF 35163

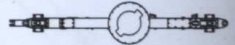

C X1 AF 35163

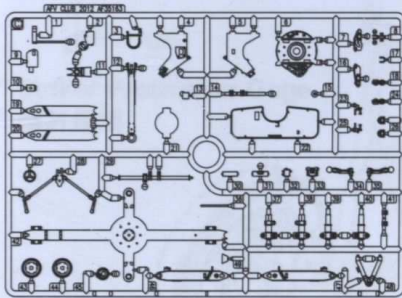

D X2 AF 35163

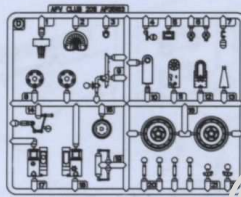

A X1 AF 35189

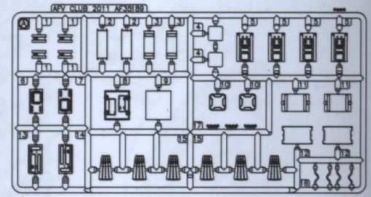

K X1 AF 35186

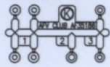

KA X4 AF 35163



G X1 AF 35163



J X1 AF 35163

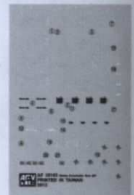

Instructions:

If for some reason, you are not fully satisfied or have questions concerning our product; Please use the form provide, and send it to our nearest representative or mail it directly to our office.

We will deal with that A.S.A.P.



AF 35163 Parts Replacement Form

- | | |
|-------------------------------------|--------------------------------------|
| <input type="checkbox"/> AF 35163-A | <input type="checkbox"/> AF 35163-J |
| <input type="checkbox"/> AF 35163-B | <input type="checkbox"/> AF 35186-K |
| <input type="checkbox"/> AF 35163-C | <input type="checkbox"/> AF 35163-KA |
| <input type="checkbox"/> AF 35163-D | <input type="checkbox"/> AF 35163-M |
| <input type="checkbox"/> AF 35163-G | <input type="checkbox"/> AF 35189-A |
| <input type="checkbox"/> AF 35163-E | <input type="checkbox"/> AF 35042-H |

Reason for replacement: Missing
 Broken

Signature: _____

限臺灣地區使用 For Taiwanese use only!

AGV CLUB AF 35163 零件補充申請表

申請人
姓名 地址 電話

- | | | |
|--------------------------------------|------|-----|
| <input type="checkbox"/> AF 35163-A | NT\$ | 200 |
| <input type="checkbox"/> AF 35163-B | NT\$ | 150 |
| <input type="checkbox"/> AF 35163-C | NT\$ | 250 |
| <input type="checkbox"/> AF 35163-D | NT\$ | 200 |
| <input type="checkbox"/> AF 35163-G | NT\$ | 180 |
| <input type="checkbox"/> AF 35163-E | NT\$ | 120 |
| <input type="checkbox"/> AF 35163-J | NT\$ | 160 |
| <input type="checkbox"/> AF 35186-K | NT\$ | 60 |
| <input type="checkbox"/> AF 35163-KA | NT\$ | 100 |
| <input type="checkbox"/> AF 35163-M | NT\$ | 160 |
| <input type="checkbox"/> AF 35189-A | NT\$ | 110 |
| <input type="checkbox"/> AF 35042-H | NT\$ | 40 |

+郵寄費 NT\$ 80
(請填)總計NT\$ _____

零件補充原因:(請於 打)
原包裝即 遺失或 毀損,
製作途中 遺失或 毀損,
其他原因 _____

總代理戰鷹企業 客服部收本公司將儘速為您處理。
請將本表與該部品相同金額之郵政匯票一同寄至。