



British Bofors QF 40mm L/60 Anti-aircraft Gun Mk III

****SPECIAL THANKS:** Imperial War Museum
Royal Artillery Museum

Located in Sweden, Bofors originates from a hammering trip hammer ~~and~~ founded 1646. The company expanded into weapons manufacture in late 19 century. Although Sweden itself did not involve in WWI, yet weapons manufacture subsidiary has become an important sector in Bofors Group.

The Swedish Navy commissioned Bofors to design a 20mm anti-aircraft cannon for ships in 1925. The Swedish Navy changed the specification to 40mm in 1928 because 20mm was considered to be insufficient. By 1930s, Krupp purchased a one-third share of Bofors. Krupp engineers started the process of updating the Bofors factories to use modern equipment and metallurgy. Acceptance trials for 40 mm akan M/32 were completed in 1932, and Dutch Navy became the first buyer in 1934. Bofors also developed a land-based m/34 on a towable carriage. The cannon was commonly known as Bofors 40mm L/60.

Giving Bofors 40mm L/60's performance has been well recognized, by 1939 it has been adopted or produced under license in no less than 18 countries, and seen actions with Allies and Axis armed forces. It is widely recognized as the most successful weapon in WWII, and also remains in service to date.

The British Government has been watching development of Bofors 40mm L/60 since 1933. The Royal Navy ordered 100 units of 40mm L/60, mounted on battleships and heavy cruisers. The land-based 40mm L/60 on a towable carriage based on Polish design was also introduced later and produced under license. From 1942, the British Army modified and produced the 40mm L/60, known as QF 40mm Mark I/III, production lines were set up in the UK, Canada and Australia. More than 2100 have been produced.

鉄工所を起源とするボフォース社が、スウェーデンに設立されたのは、1646年のことであり、19世紀後期に兵器の製造を開始した。第一次世界大戦が勃発すると、スウェーデンは参戦しなかったものの、兵器の需要は拡大し、それまで副次的な位置づけであった兵器製造部門は、一転してボフォースグループのなかで、重要な地位を占めるに至ったのである。

1925年、スウェーデン海軍は艦艇搭載用の防空火器として口径20mmの対空砲の設計を依頼した。1928年になると20mm砲の威力に不足を感じたスウェーデン海軍は、口径の仕様設定を40mmに変更した。1930年代に入り、軍備制限下にあったドイツのクルップ社が、ボフォース社の株式の1/3を取得、クルップの技術者は近代的な設備や冶金技術を活用するために、ボフォースの工場の更新に着手した。1932年、40mm akan M/32は試用の結果、合格、1934年にオランダ海軍が最初の購入者となった。ボフォースは、車輛牽引・移動式の地上用タイプM/34も開発し、これはボフォース40mm L/60として知られている。

ボフォース40mm対空砲L/60が高い評価を得ていたことは、1939年までに18以上の国が採用、ライセンス生産していた事実がなよりの証拠であり、それは連合軍のみならず枢軸軍でも使用されていたのである。この対空砲が、第二次大戦期間において最も成功した兵器のひとつであることは、広く認められていることで、現在でも多くの国の軍隊で、使用されているのである。

1933年以来、ボフォースの40mm対空砲L/60の開発に注目していた英国政府は、海軍の戦艦、重巡洋艦に搭載するため、100門の購入を決定した。また、ポーランド軍仕様をベースにした牽引・移動式の地上型を導入、後にライセンス生産を開始した。1942年より、英陸軍は40mm L60を改良、QF40mm Mk I / IIIとして生産を始め生産ラインは英国内、カナダ、オーストラリアにまで設置され、2100門以上が製造されたのであった。

設立於瑞典的波佛斯是一間由鐵匠鋪逐步發跡，歷史悠久的鋼鐵工業公司。十九世紀末波佛斯開始涉足軍火工業，在歐洲經歷了第一次世界大戰的洗禮後，雖然瑞典並未捲入戰火，但卻確立了軍火項目在波佛斯旗下的重要地位。

1925年瑞典海軍委託波佛斯設計一款供艦艇使用的防空火炮，最初的計畫是20mm口徑，但由於對這種小口徑火炮威力的質疑，在1928年瑞典海軍修訂了原本的規格，大幅提升為40mm口徑。1930年時，受到軍事限制下的德國克虜伯公司取得波佛斯三分之一股權，並引進了現代化的設備與冶金技術。到了1932年，被命名為40mm akan M/32的這型火炮問市，1934年荷蘭海軍搶在瑞典海軍之前成為這型火炮最早的買主。稍後波佛斯並開發可由車輛牽引移動的陸基型m/34，但各界通常會以波佛斯40mm L/60來統稱這一系列火炮。

由於波佛斯40mm L/60的性能得到肯定，許多國家在取得了波佛斯的授權而自行生產。在1939年歐戰爆發前已經有18個國家生產或採用，成為少數同時在同盟國與軸心國軍隊中服役的武器，堪稱是二戰期間最為成功的武器之一，至今仍然活躍在許多國家的軍隊之中。

英國在1933年時便已關注波佛斯40mm L/60的發展，1937年英國決定向瑞典購買一百門波佛斯40mm L/60配備於戰列艦與重巡洋艦之上，而後又由波蘭引進授權生產的牽引型波佛斯40mm L/60。1942年開始，英國改良了部分設計並自行生產同型火炮，英國型的陸基火炮型號為QF 40mm Mark I/III，分別在英國本土與加拿大、澳大利亞生產，產量在2100門以上。

Illustration: 圖示說明



Method For Applying Decals:

1. Clean Model Surface With Wet Cloth.
2. Cut Out Of Decal Sheet And Dip Them In Warm Water For 15 Seconds.
3. Place it on proper position on model.
4. Slide off base paper leaving decals On Model With Wet Finger Tip.
5. Move Decals To Exact Position, Push Out Excess Water Under Decal With Soft Cotton Cloth.
6. When Decals Get Dry Then Complete.

水貼紙使用說明:

1. 將模型表面擦乾淨
2. 將貼紙剪下泡入溫水中浸泡約15秒
3. 將泡濕之貼紙取出置於欲貼處旁
4. 用指尖輕推貼紙表面使其滑出底紙
5. 將貼紙調整至適當位置並輕擦拭水份
6. 待其自然乾燥後即完成

Color list: 塗料表

Color	Brand	Gunsangyo			Humbrol	Revell	Lifecolor
		Hobby Color	Mr.Color	Mr.Color Spray			
Aluminum	鋁		MC218		27001-6	99	
Brass	黃銅	H9	C9	J9	54	92	LC75
Khaki green	卡其綠	H50	C54				
Red brown	紅褐	H47	C41		160	383	UA085
Steel	黑鐵	H18	C28	J28	53	91	LC76
Tire black	輪胎黑	H77	C33+C62		85	302	LC02
Wood brown	木棕	H37	C43		169		FS12
Yellow FS13538	黃	H329	C329		188		LC53

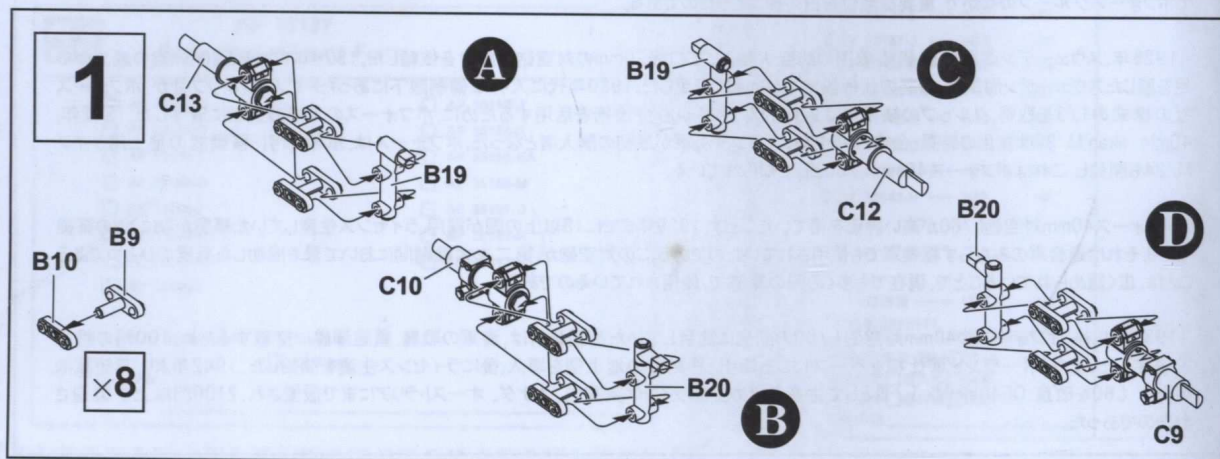

2

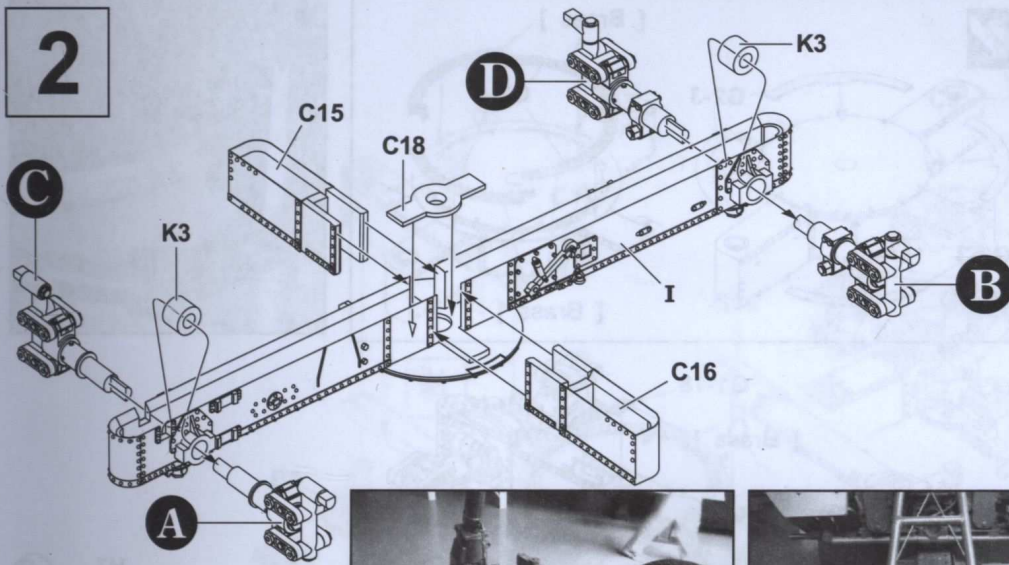

3

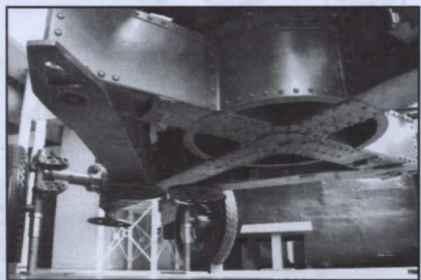
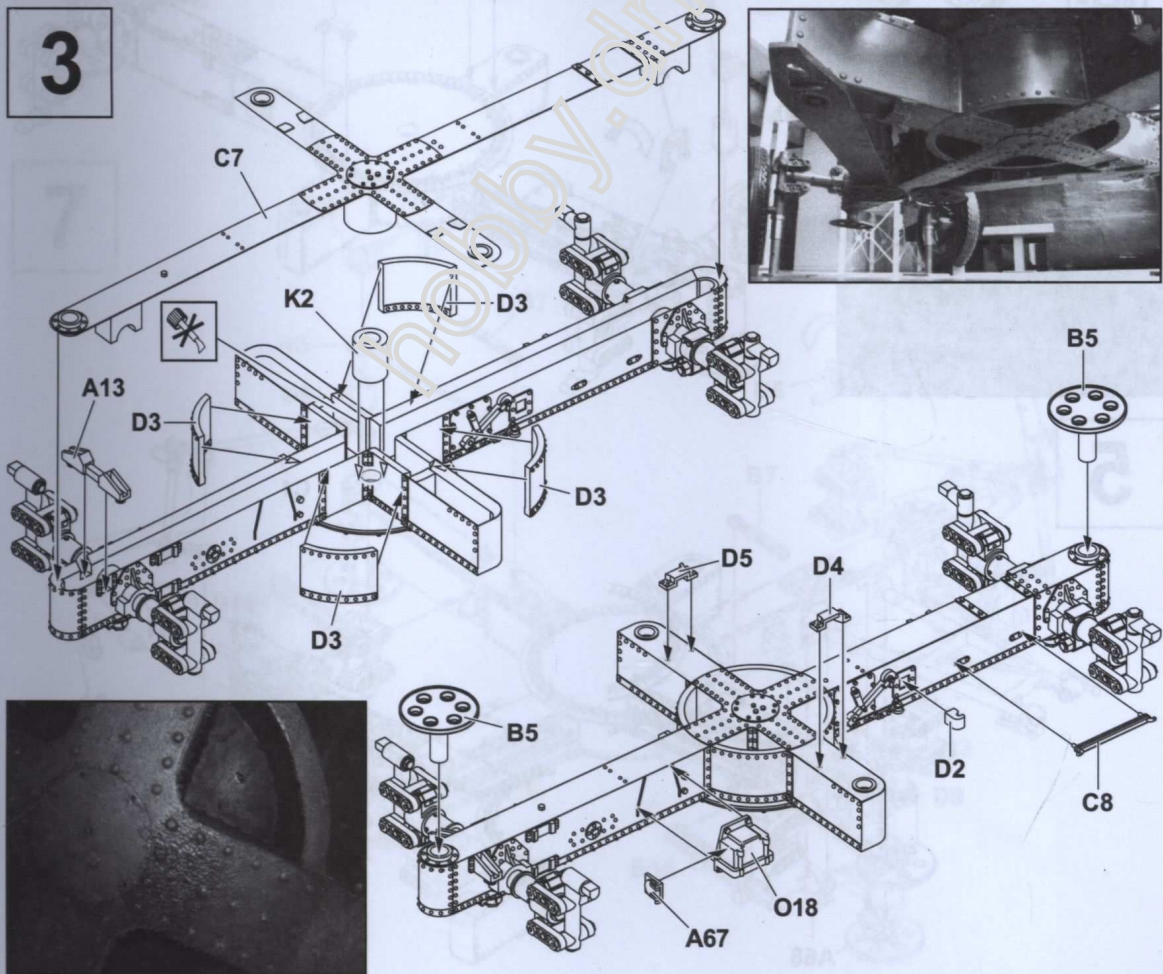

4

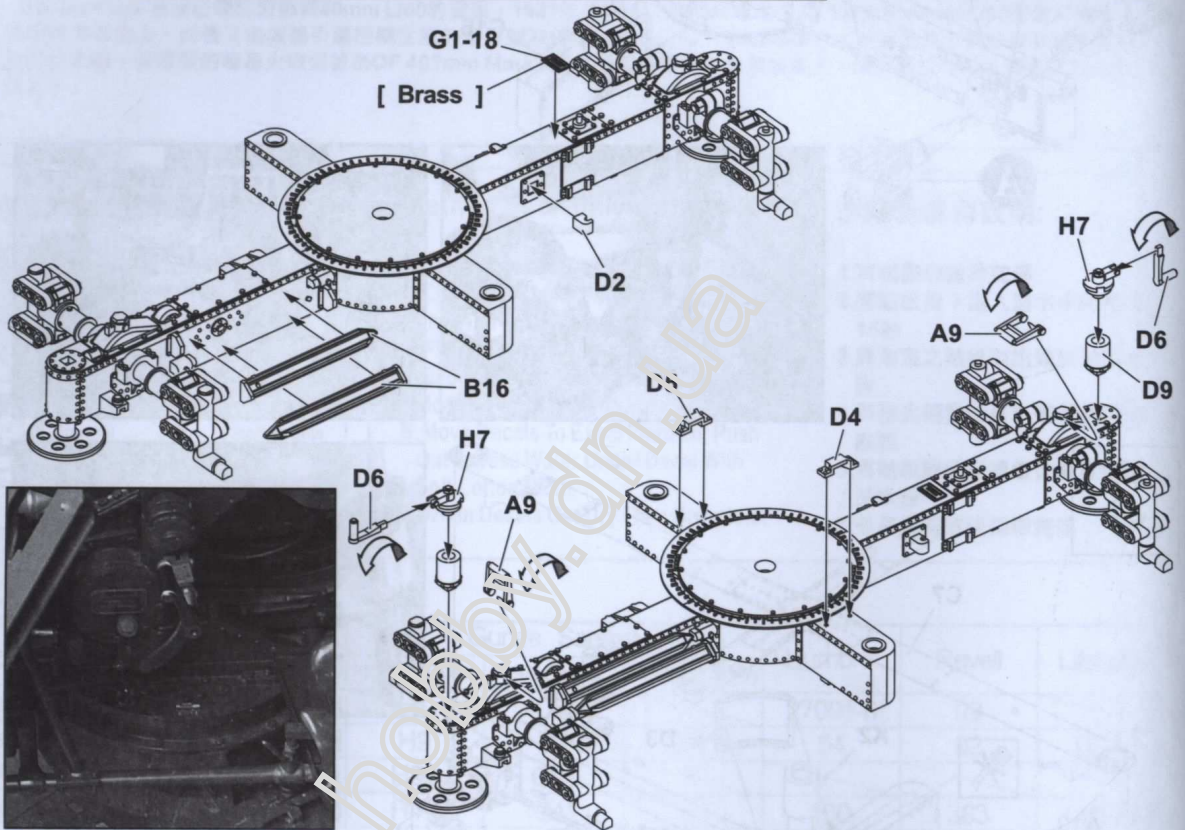
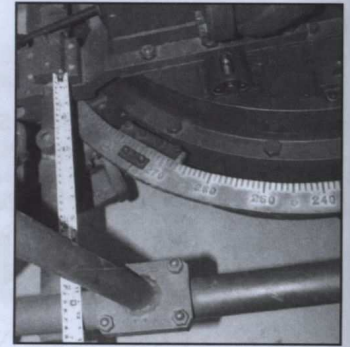
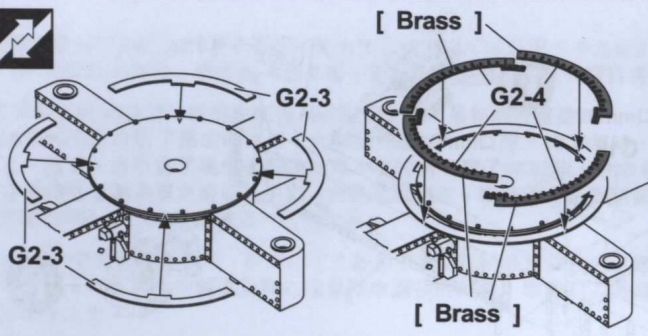

5

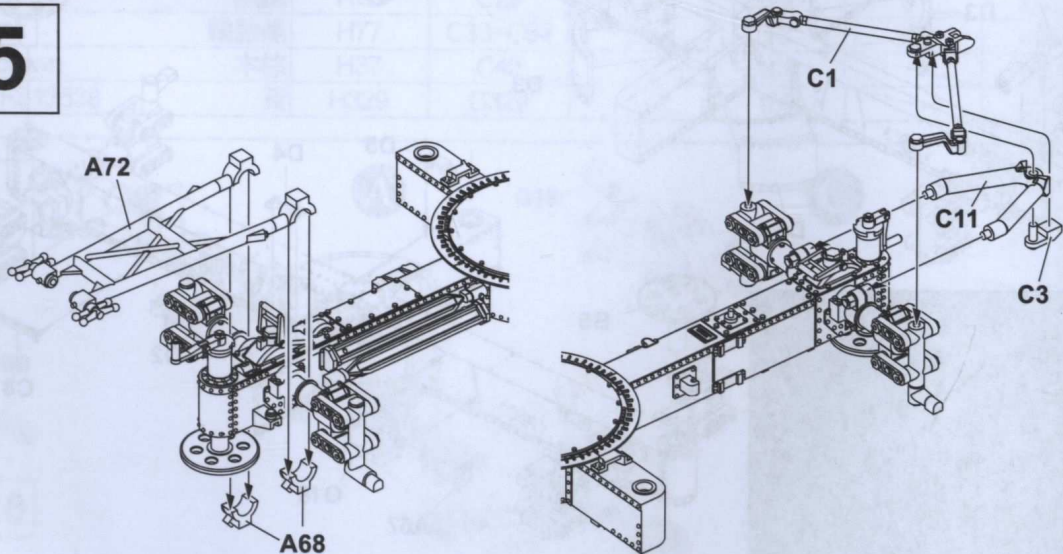

6

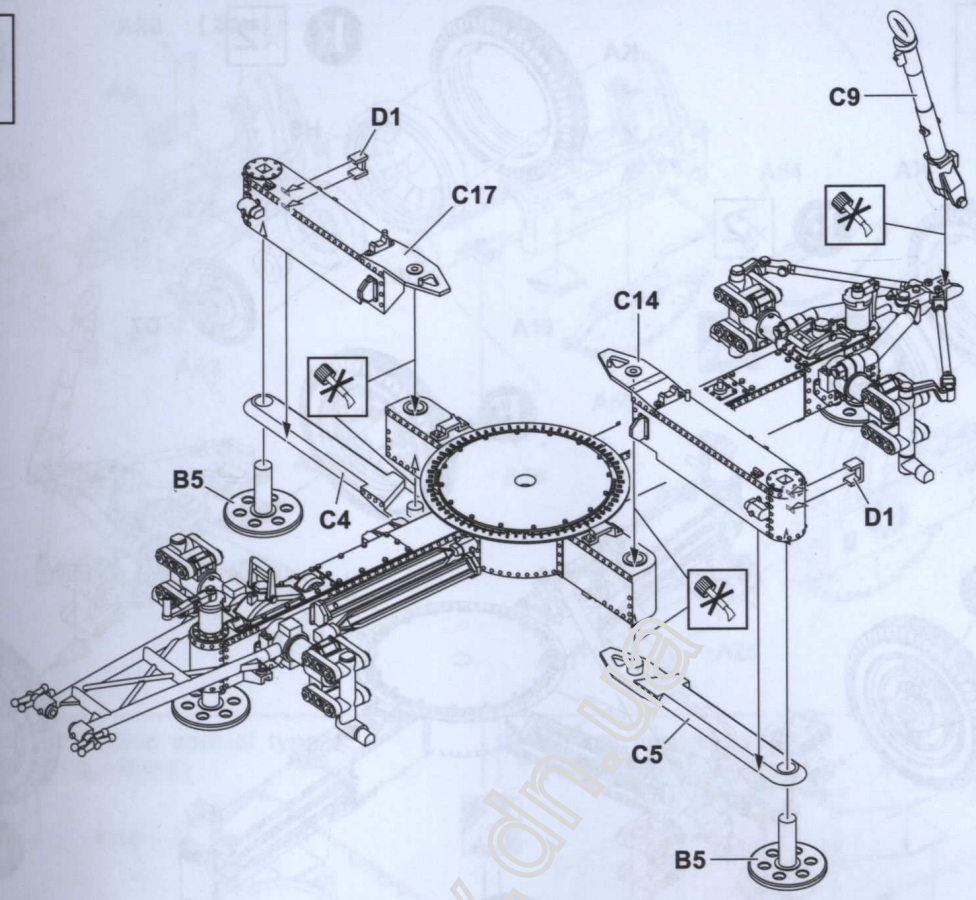

7

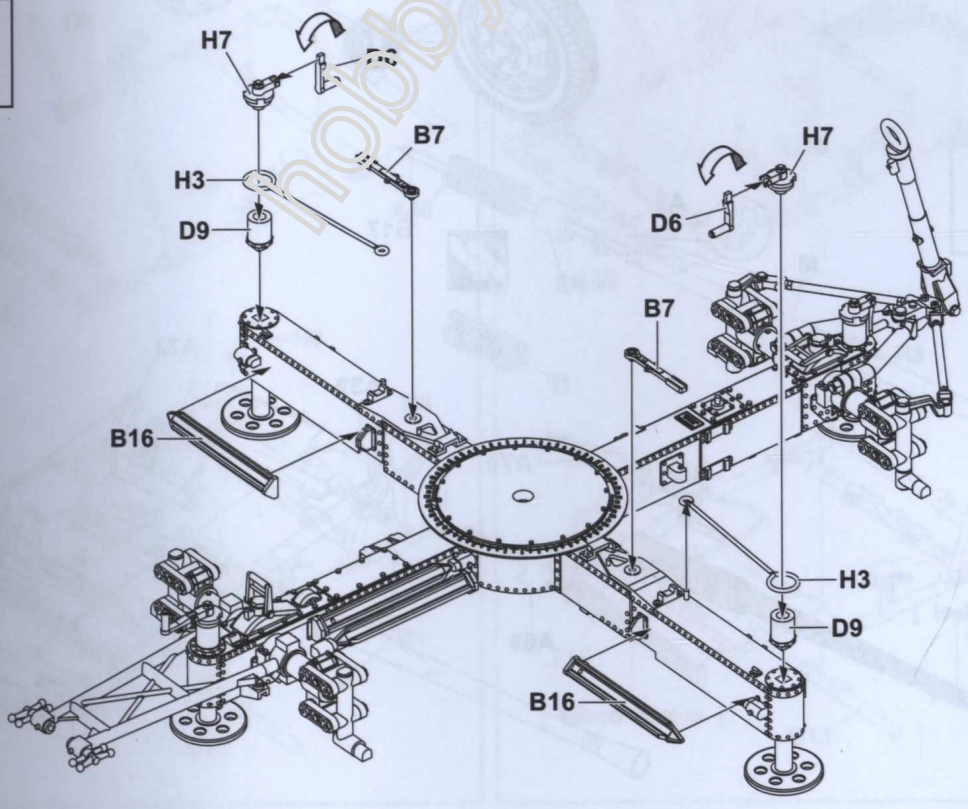

8

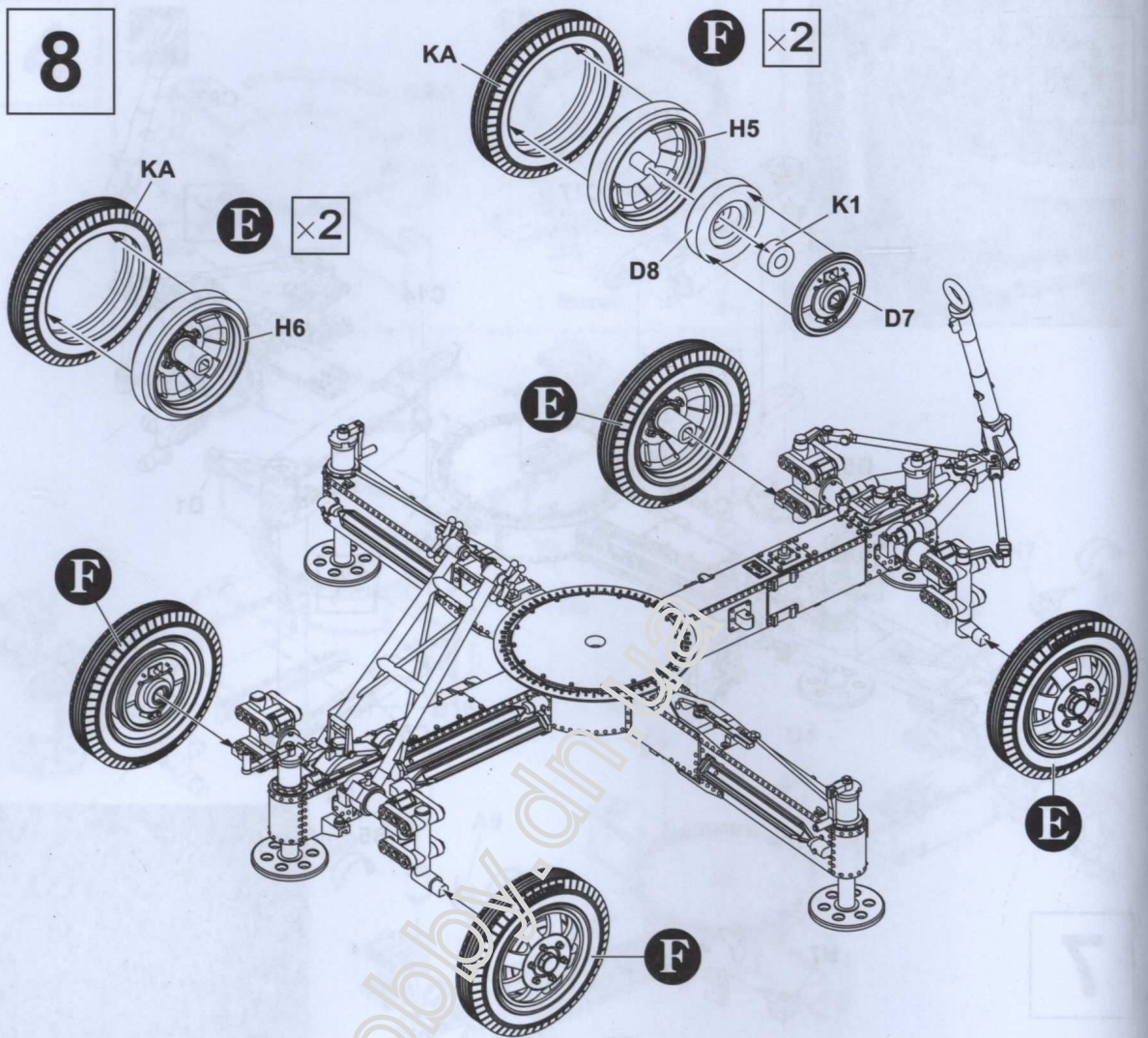

9

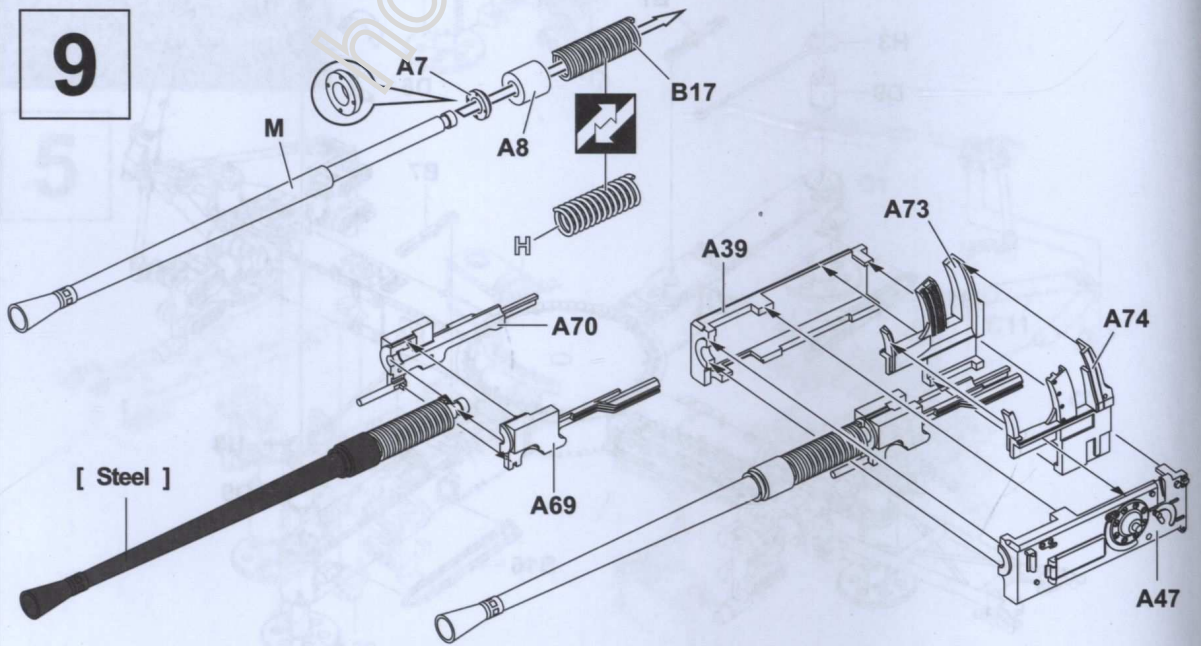

10

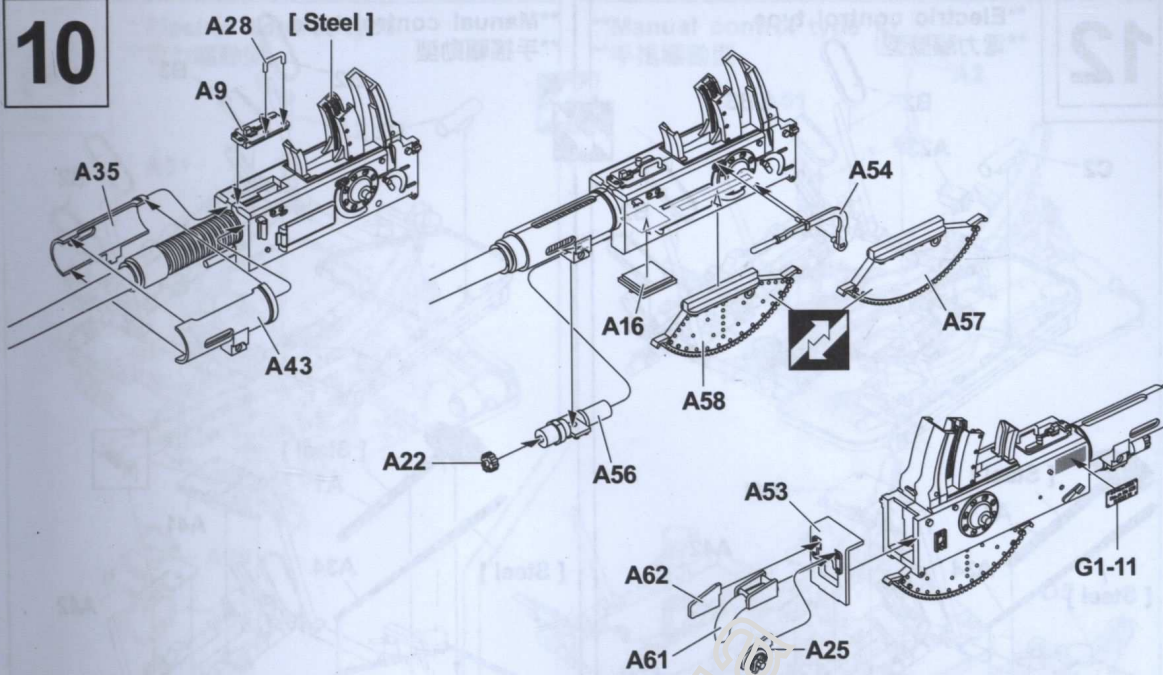

11

**Electric control type
**電力駆動型

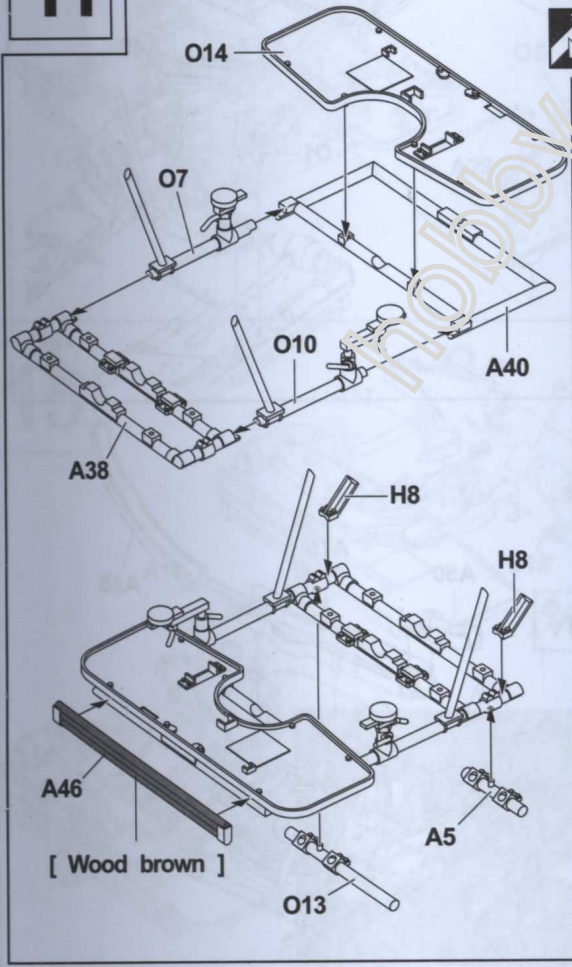

**Manual control type
**手動駆動型

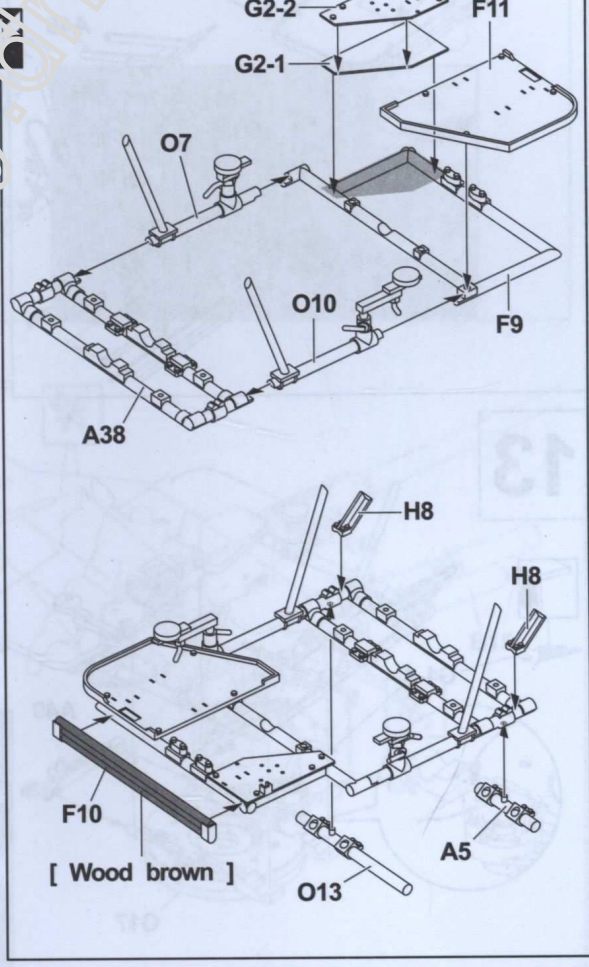

12

**Electric control type
**電力驅動型

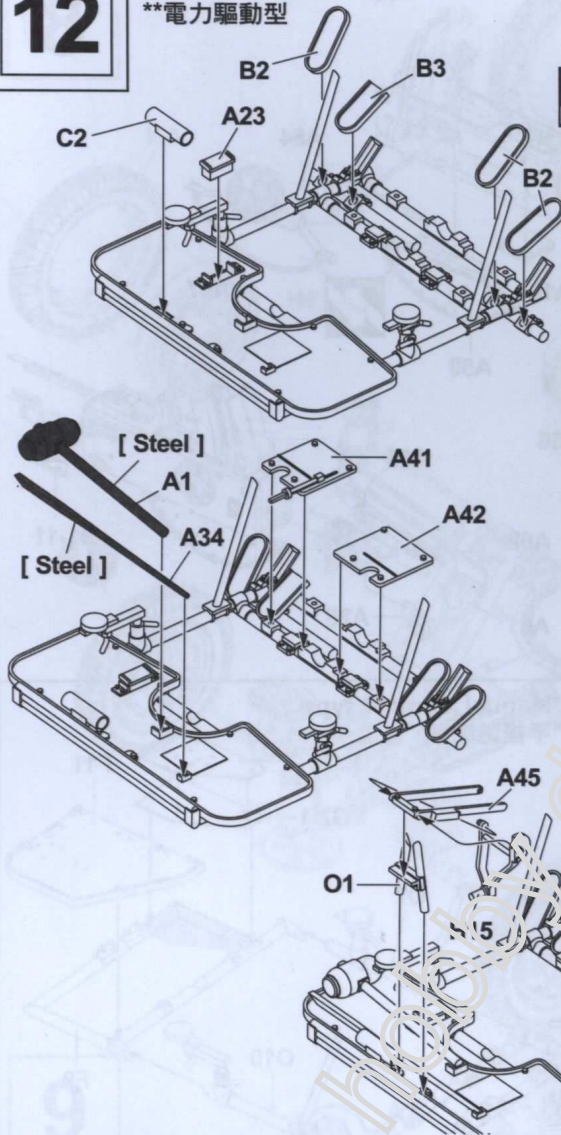

**Manual control type
**手搖驅動型

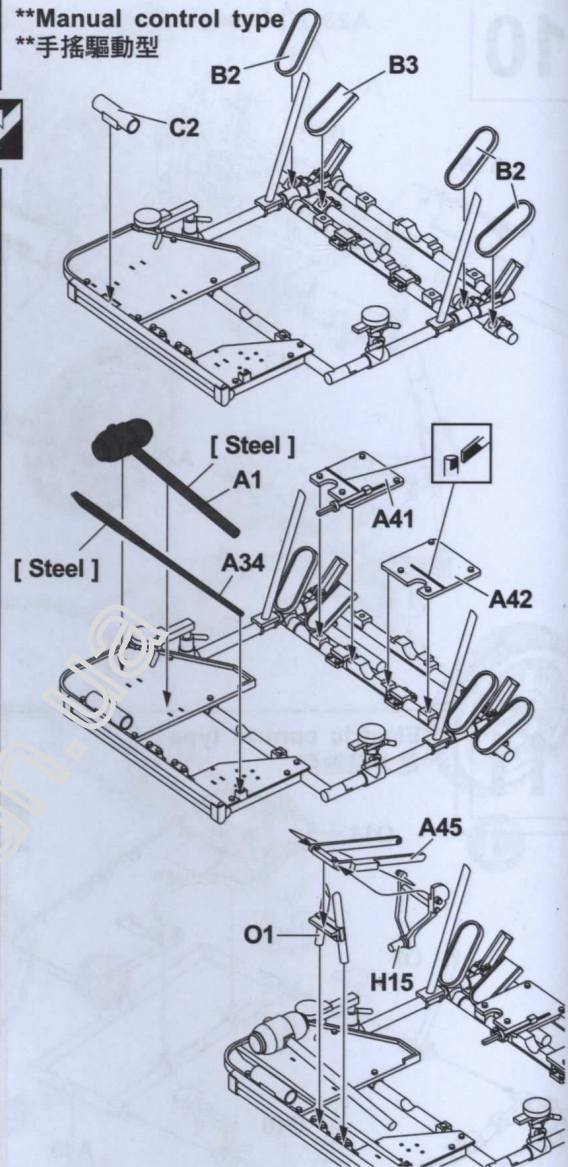

13

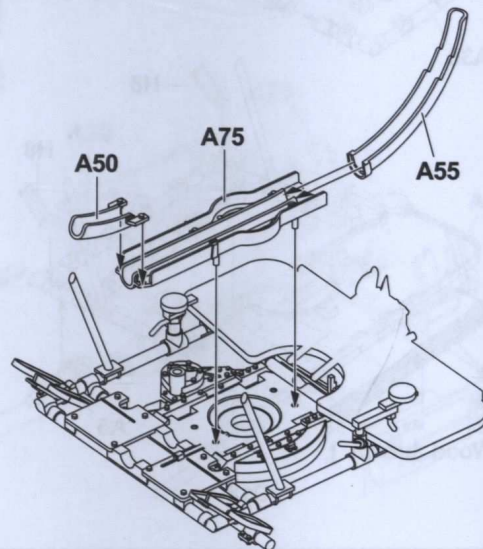
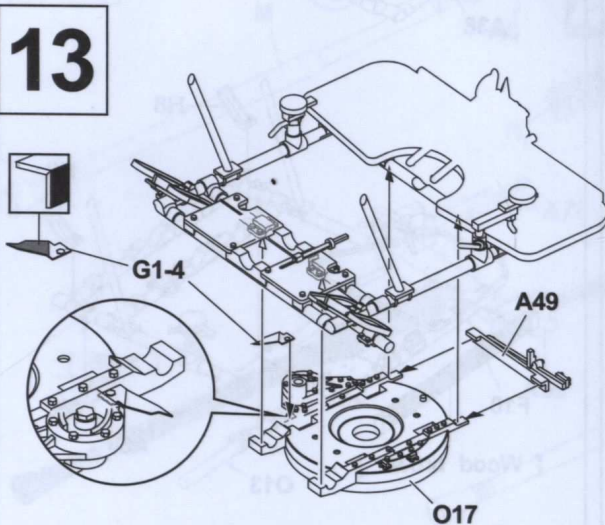

14

**Electric control type
**電力驅動型

**Manual control type
**手搖驅動型

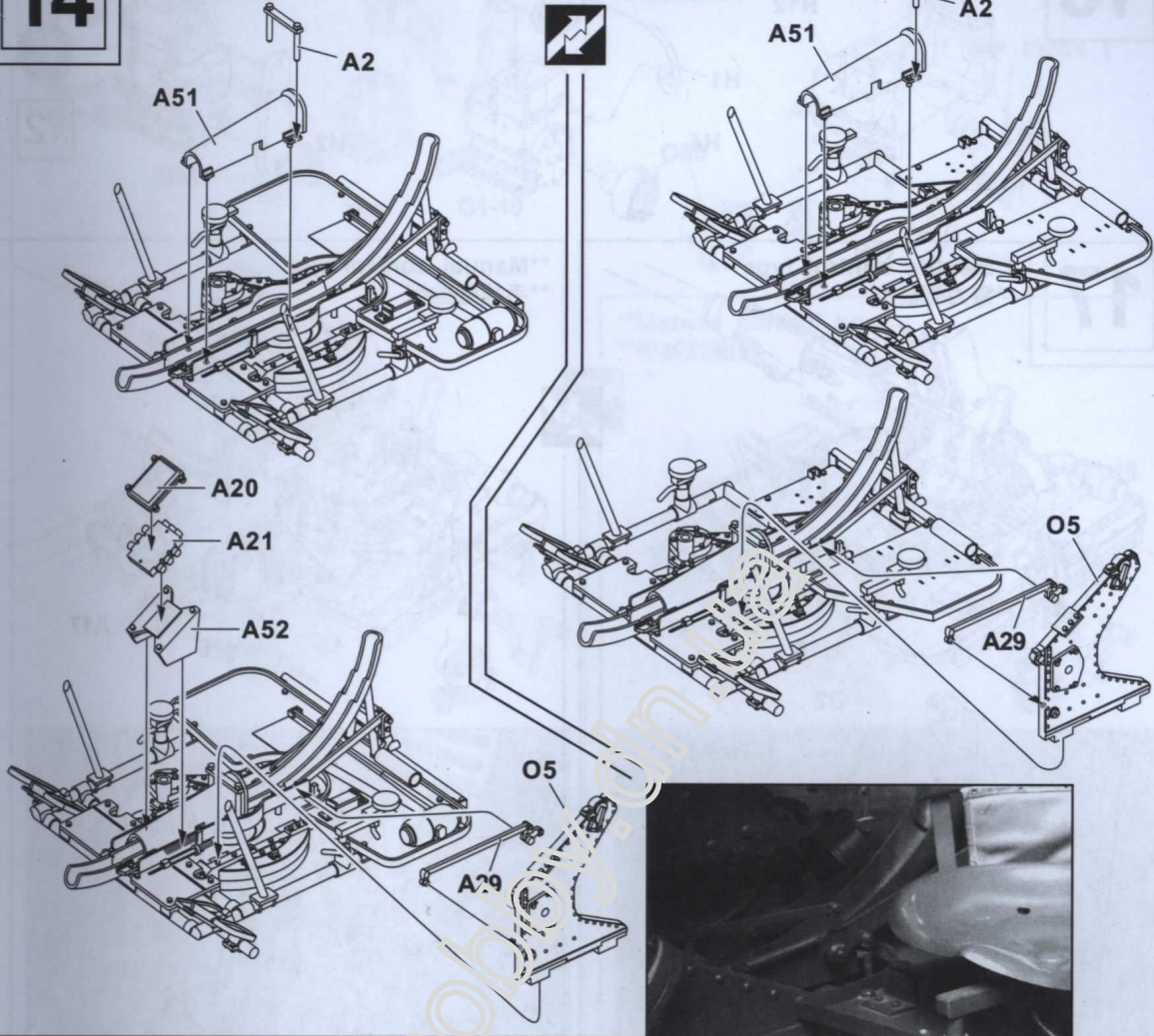

15

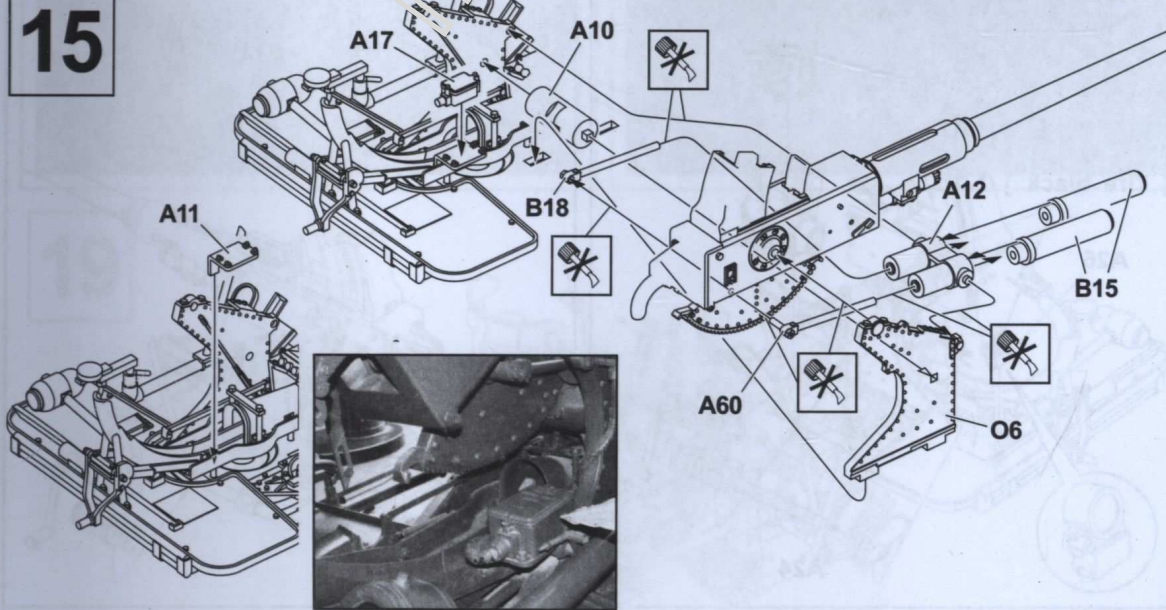

16

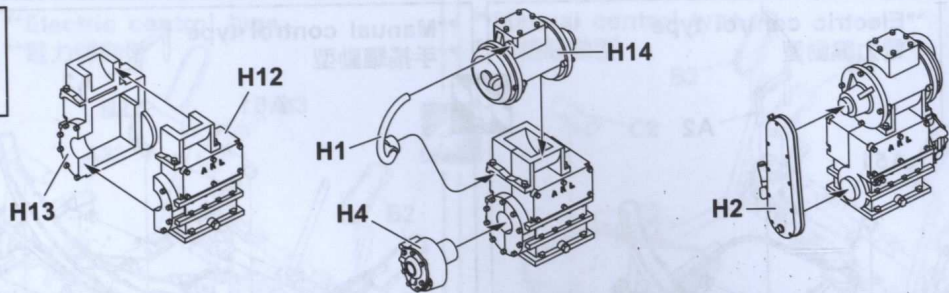

17

**Electric control type
**電力驅動型

**Manual control type
**手搖驅動型

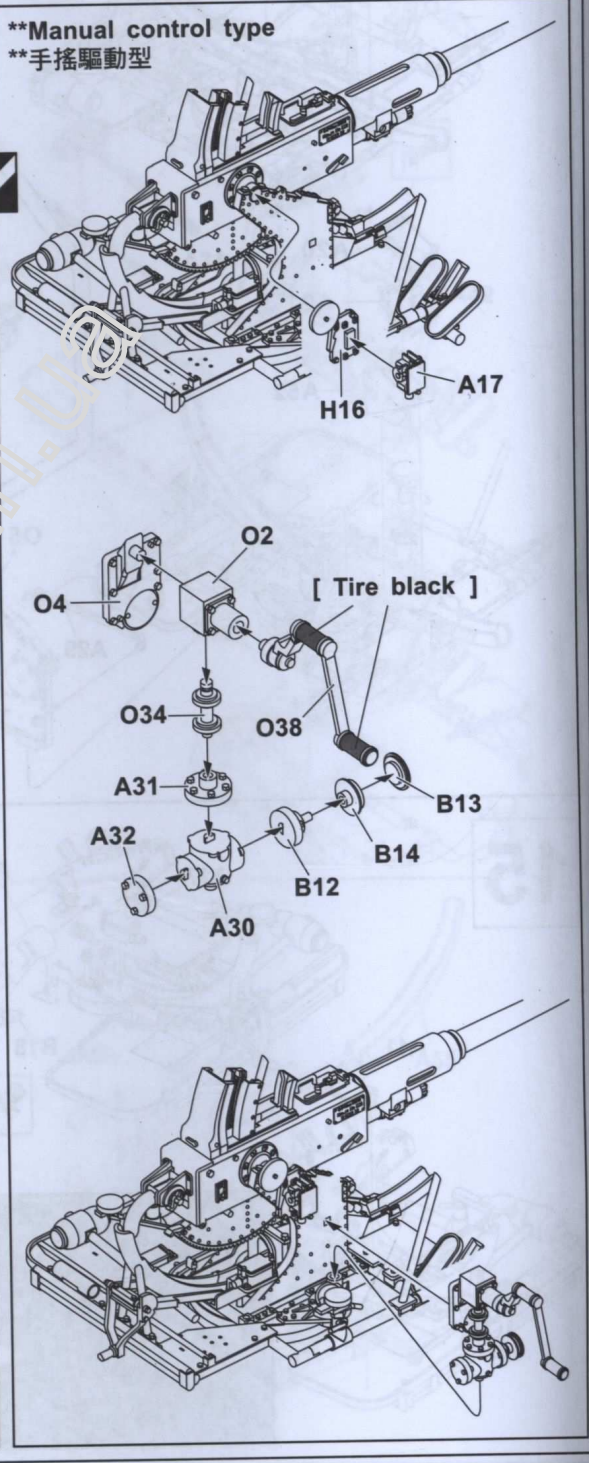
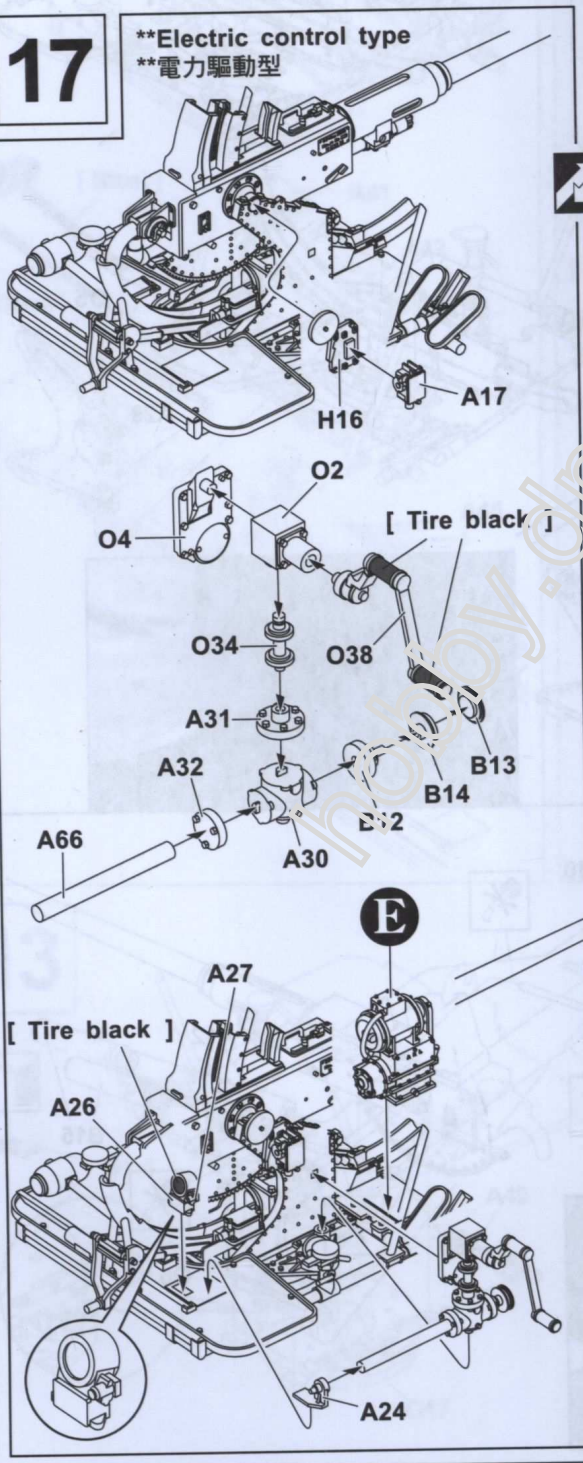

18

**Electric control type
**電力驅動型

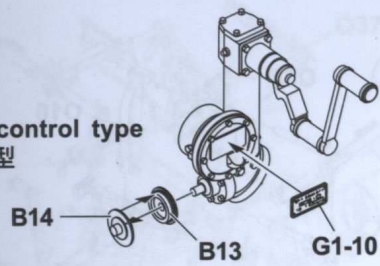

E

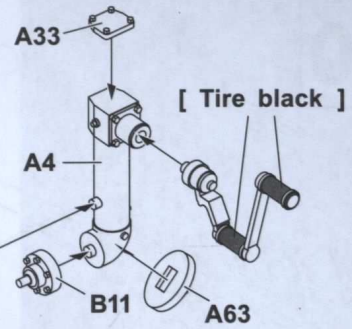
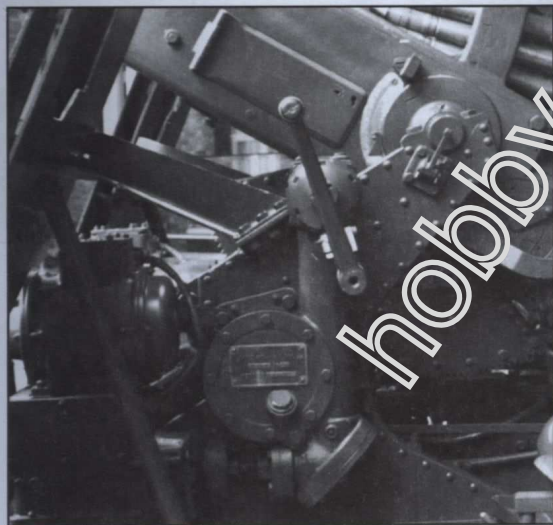
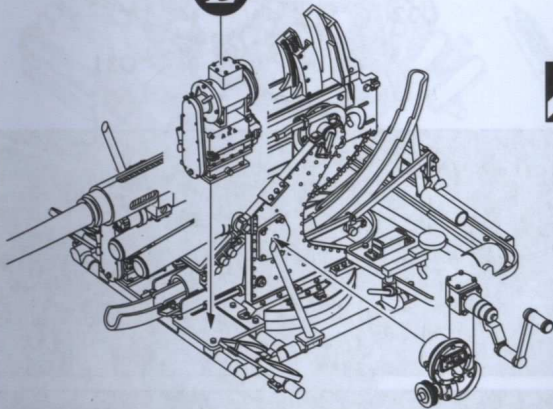

**Manual control type
**手搖驅動型

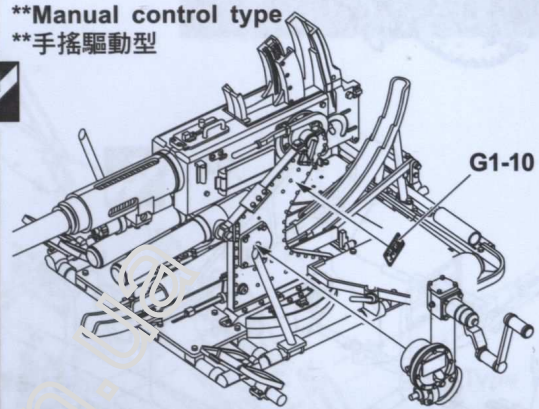

19

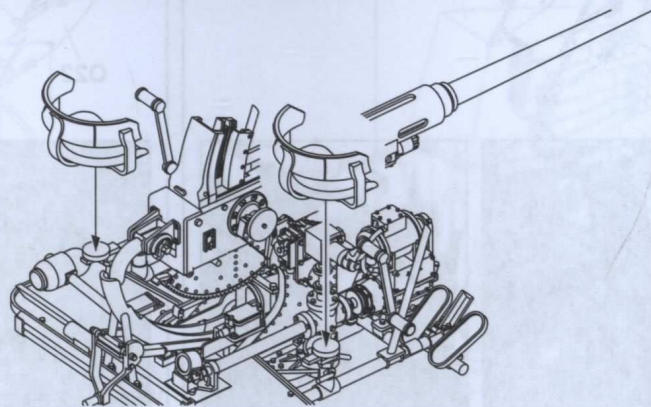

20

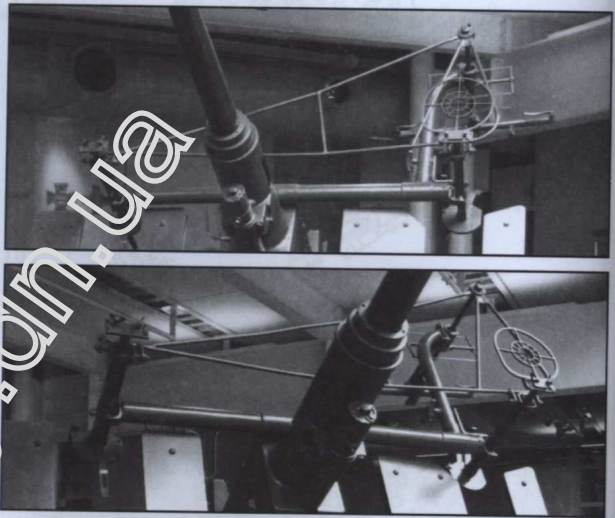
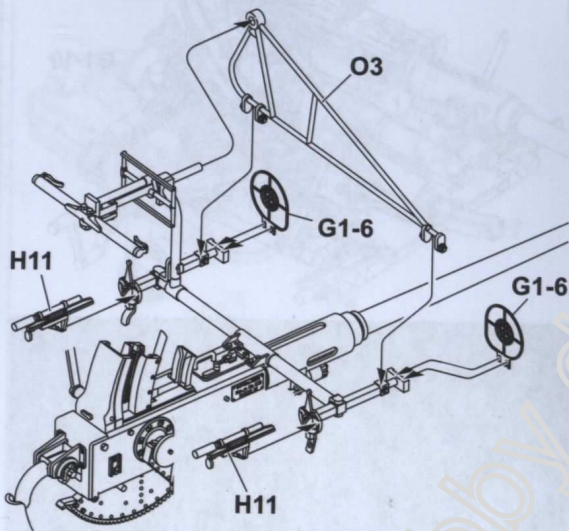
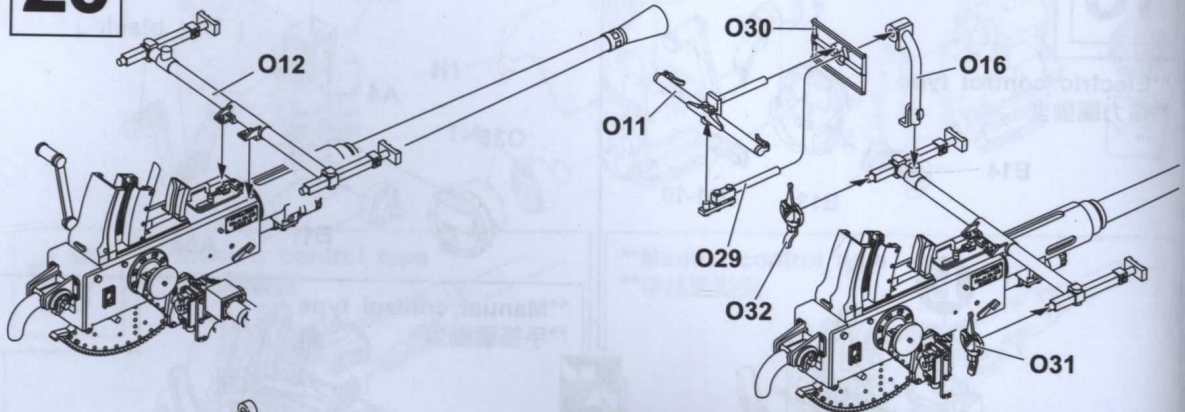

21

Type A

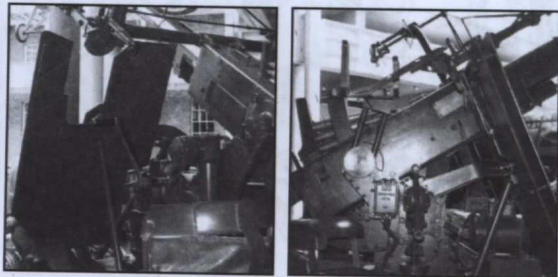
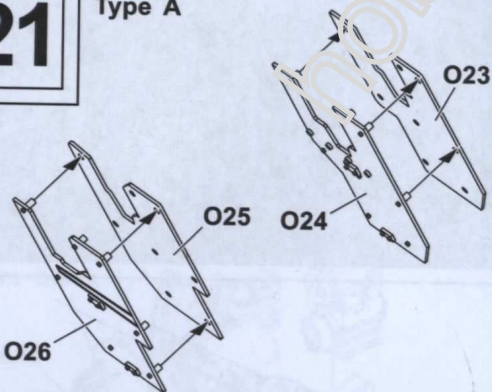

Type B

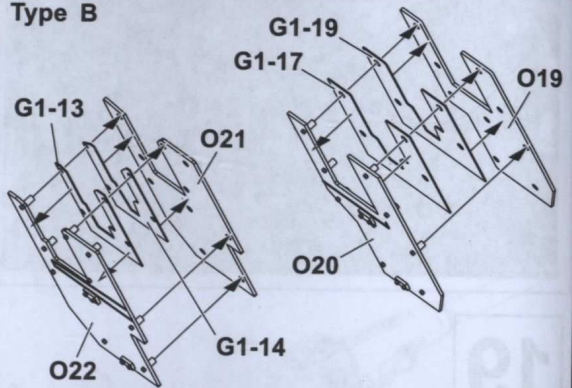

22

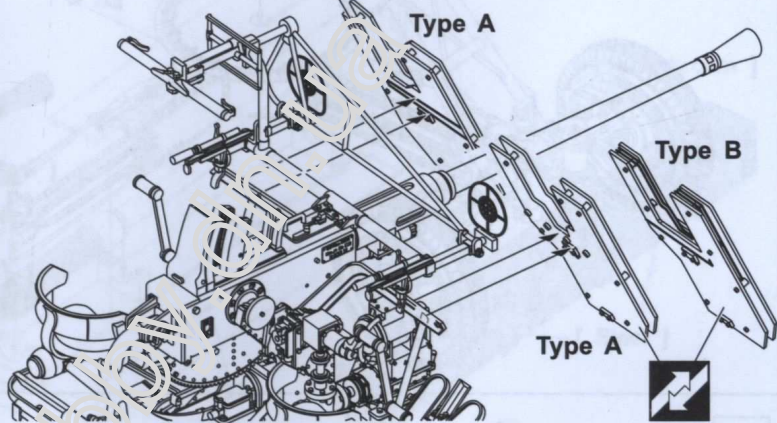
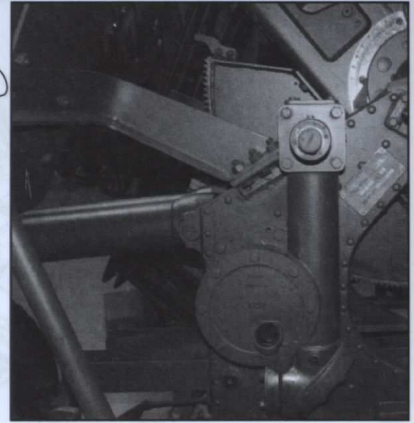
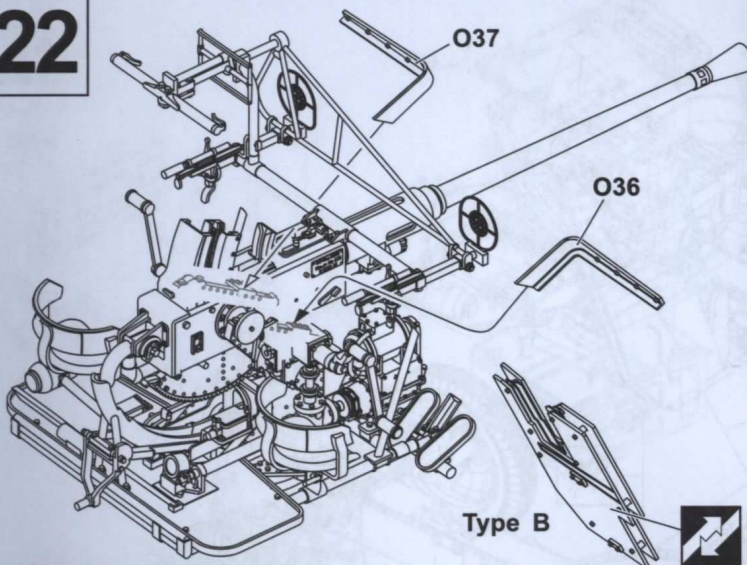

23

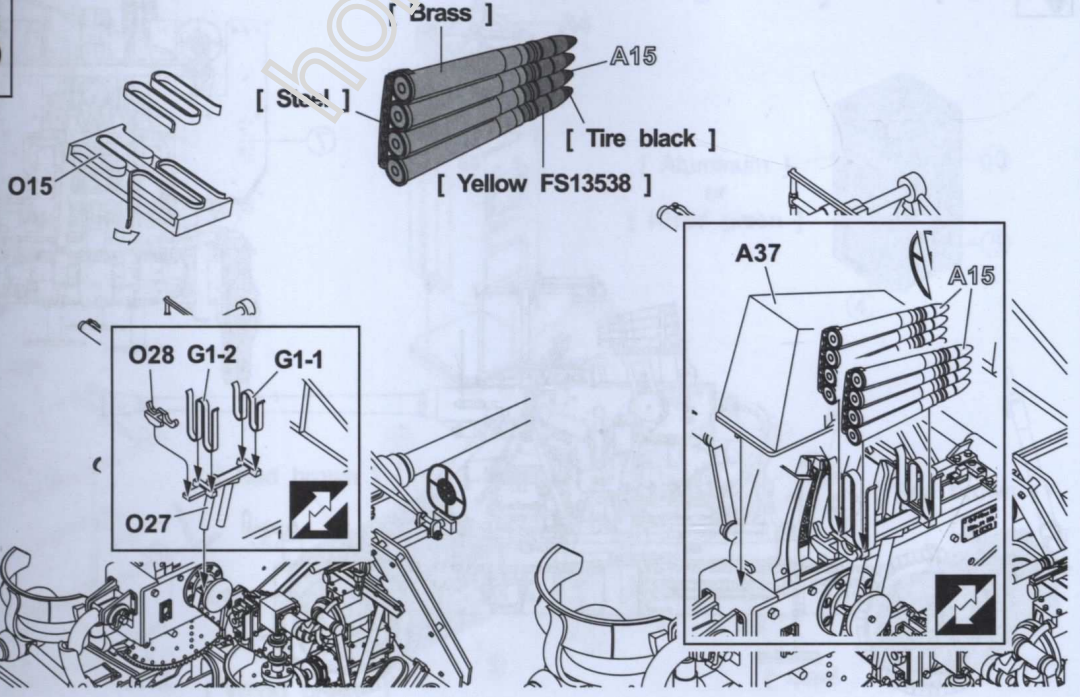

24

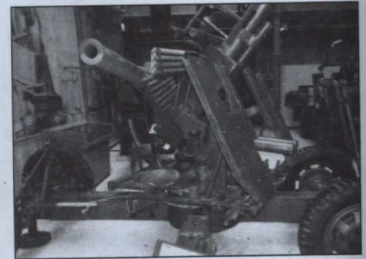
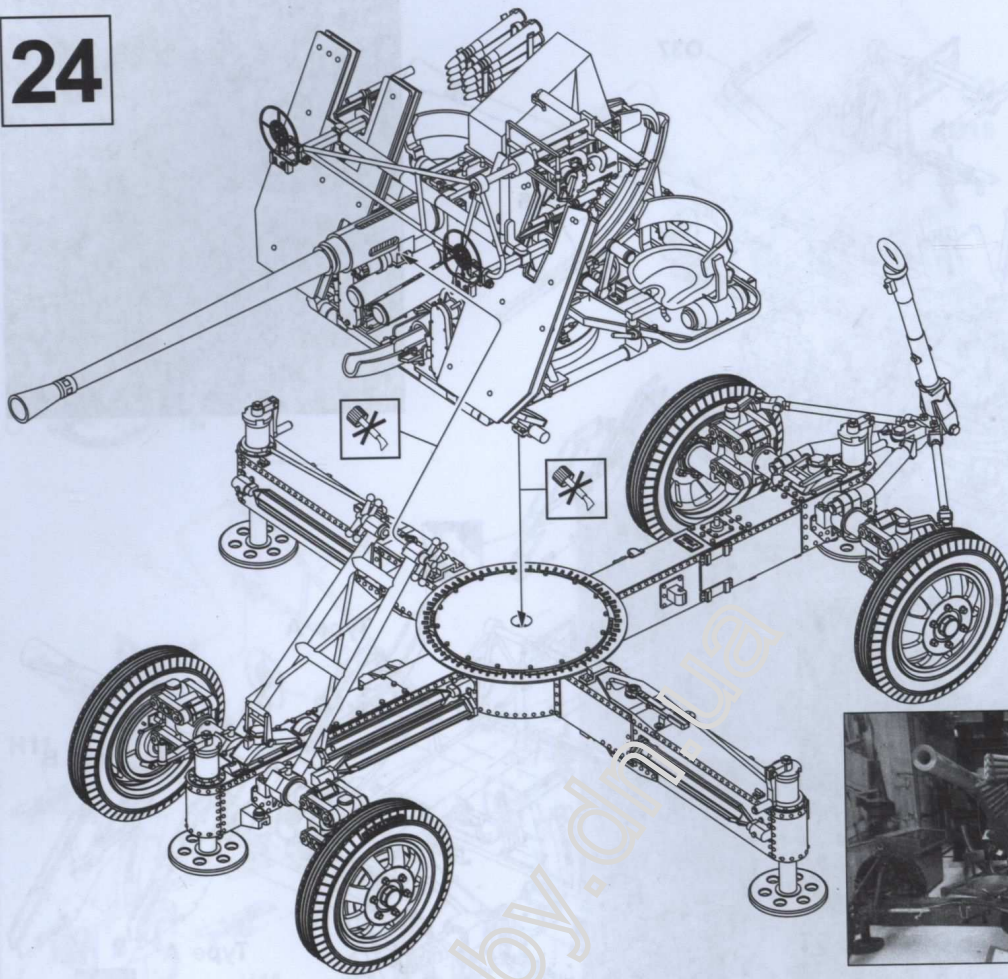

 Body Color: Khaki green

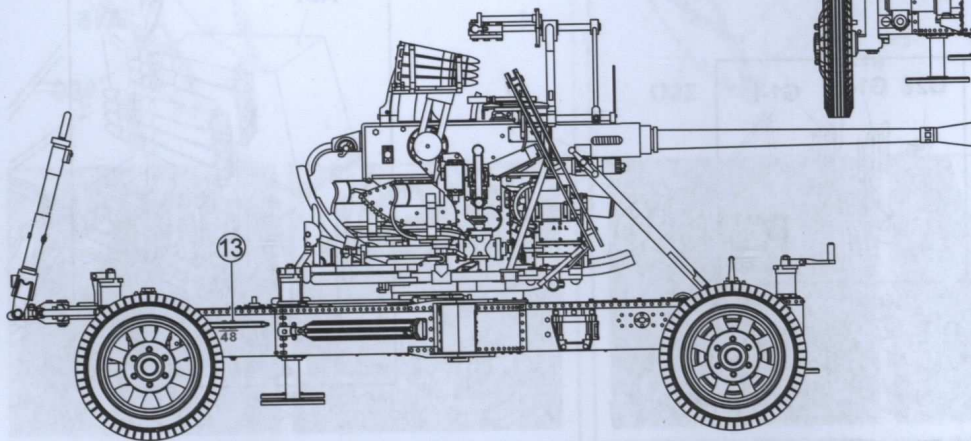
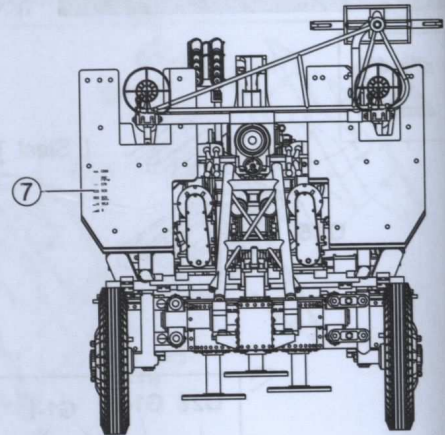

25

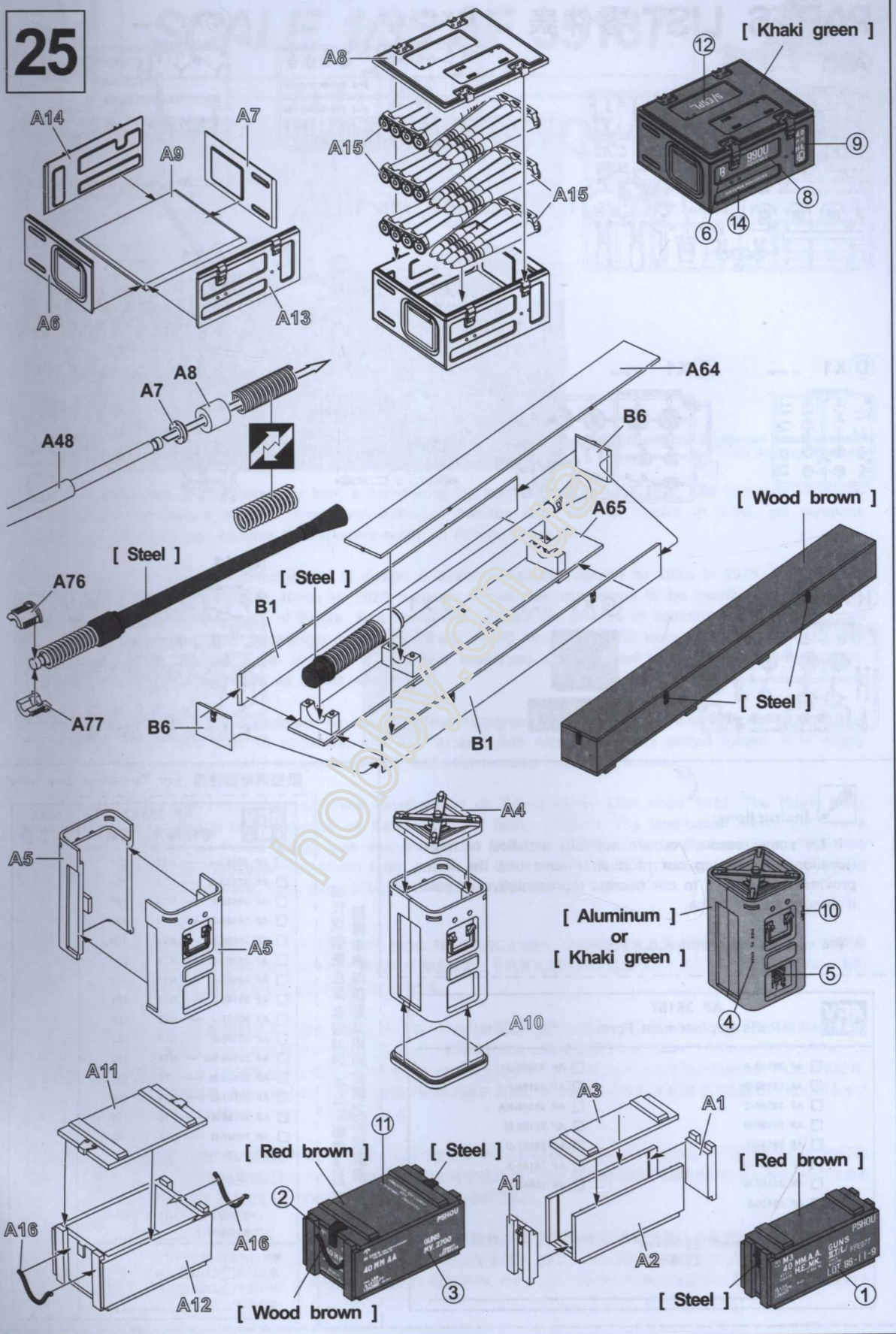

PARTS LIST 零件表

A X1 AF 35163

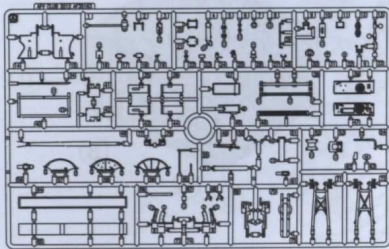

B X1 AF 35163

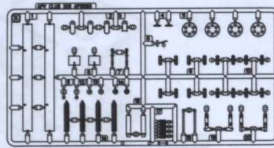

C X1 AF 35186

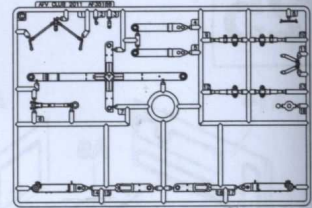

M X1 AF 35163



H X1 AF 35042



A X1 AF 35189

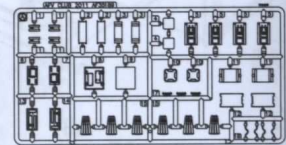

D X1 AF 35186

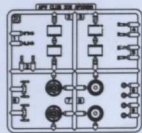

F X1 AF 35186

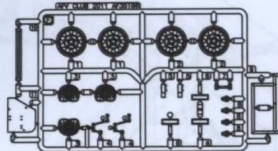

I X1 AF 35186

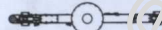

K X1 AF 35186



KA X4 AF 35186



H X1 AF 35187

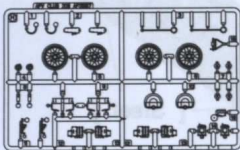

G X1 AF 35187



J X1 AF 35187



O X1 AF 35187

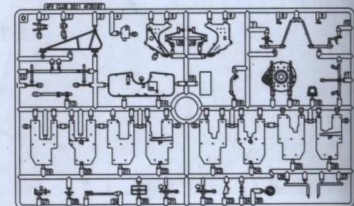

Instructions:

If for some reason, you are not fully satisfied or have questions concerning our product, please use the form provided, and send it to our nearest representative or mail it directly to our office.

We will deal with that A.S.A.P.



AF 35187 Parts Replacement Form

- | | |
|-------------------------------------|--------------------------------------|
| <input type="checkbox"/> AF 35163-A | <input type="checkbox"/> AF 35187-J |
| <input type="checkbox"/> AF 35163-B | <input type="checkbox"/> AF 35186-K |
| <input type="checkbox"/> AF 35186-C | <input type="checkbox"/> AF 35186-KA |
| <input type="checkbox"/> AF 35186-D | <input type="checkbox"/> AF 35163-M |
| <input type="checkbox"/> AF 35186-F | <input type="checkbox"/> AF 35187-O |
| <input type="checkbox"/> AF 35187-G | <input type="checkbox"/> AF 35189-A |
| <input type="checkbox"/> AF 35187-H | <input type="checkbox"/> AF 35042-H |
| <input type="checkbox"/> AF 35186-I | |

Reason for replacement: Missing
 Broken

Signature: _____

限臺灣地區使用 For Taiwanese use only!



AF 35187 零件補充申請表

申請人姓名地址電話

- | | |
|--------------------------------------|----------|
| <input type="checkbox"/> AF 35163-A | NT\$ 200 |
| <input type="checkbox"/> AF 35163-B | NT\$ 150 |
| <input type="checkbox"/> AF 35186-C | NT\$ 180 |
| <input type="checkbox"/> AF 35186-D | NT\$ 120 |
| <input type="checkbox"/> AF 35186-F | NT\$ 150 |
| <input type="checkbox"/> AF 35187-G | NT\$ 200 |
| <input type="checkbox"/> AF 35187-H | NT\$ 150 |
| <input type="checkbox"/> AF 35186-I | NT\$ 120 |
| <input type="checkbox"/> AF 35187-J | NT\$ 160 |
| <input type="checkbox"/> AF 35186-K | NT\$ 60 |
| <input type="checkbox"/> AF 35186-KA | NT\$ 100 |
| <input type="checkbox"/> AF 35163-M | NT\$ 160 |
| <input type="checkbox"/> AF 35187-O | NT\$ 180 |
| <input type="checkbox"/> AF 35189-A | NT\$ 110 |
| <input type="checkbox"/> AF 35042-H | NT\$ 40 |

+郵寄費 NT\$ 80

(請填)總計NT\$ _____

零件補充原因:(請於□打√)
原包裝即□遺失或□毀損,
製作途中□遺失或□毀損,
其他原因 _____

總代理: 戰鷹企業 客服部 收本公司將儘速為您處理。
請將本表與該部品相同金額之郵政匯票一同寄至