



## Husky Mk III

**VMMD W/ Interrogation arm**

哈士奇Mk III行地雷探測器搭載車 吊臂型

Special thanks from the bottom of our heart to  
Brent Sauer  
Joseph Szczygielski  
Ralph Zwilling

Landmines were seriously abused in Angola and Namibia when they involved in the South African Border War broke out in 1966. Landmines as many as the local population were buried in these two countries. Since 70' s of the last century, the South African National Defense Forces tried to clear them out. Thus, they accumulated much experience of mine detection and clearance. In order to improve the efficiency, vehicle mounted mine detecting systems were used by the military, and proved their ability.

Early in 21st century, the US military involved in the Afghanistan and Iraq wars. The organized forces of their opponents were quickly overwhelmed in conventional warfare, benefited by the technical gap of numerous generations between two sides. However, armed insurgents against the US armed forces were subdivided into countless smaller cells. They widely used improvised explosive devices to attack and create harassment, caused significant threats to the US-led coalition forces and even civilians. More than 60% of US casualties were caused by such devices constructed of hand grenades or shells.

The Husky Vehicle Mounted Mine Detector produced by South Africa based RSD of Dorbyl Ltd was originally developed for the South African Defense Force. After testing in the United States, it was awarded order from the US Army. Husky entered service with engineering units of the US Army and Marine Corps in 2007. Differ from previous mine detection vehicles, Husky VMMD is engineered in modular configuration. Very little ground pressure allows it to run over landmines without detonating them. The V-shaped hull and high ground clearance of Husky can protect it from blast even the landmine detonated. The front and rear modules can be field repaired in short time in case of blasted. The Husky VMMD can clear a path up to three meters wide, determine the type of device and mark its location for follow-up interrogation by subsequent vehicles. Numerous of life of soldiers and civilians were saved along with the deployment of Husky, especially in Afghanistan where huge number of improvised explosive devices buried. The US Army and Marine Corps tested the new Husky Mk.III in 2010, proved that it is capable of withstanding the blast of 15 kgs TNT, and it is safe to the operator even explosion occurs under the wheel. Thus they award further order of Husky and active in the development of the follow-up versions.

1966年、南アフリカで国境紛争が勃発すると、アンゴラとナミビアでは地雷が大量に使用され、その地域に住む住民と同じ位の数の地雷がこの2か国に埋設されたといわれています。南アフリカ国防軍は、1970年代から、これらの地雷を取り除く作業を通じて、地雷の発見と除去に関する豊富な経験を積んでいきました。やがて、作業の効率を上げるために地雷探知機を搭載した車輛が運用され、その有効性が実証されたのです。

21世紀に入り、米軍はアフガニスタンやイラクとの戦闘に加わりました。技術的優位性により、敵の主要な軍隊を短期間で制圧しましたが、残った敵勢力は無数に分散して米軍に抵抗を続けるようになったのです。彼らの簡易な爆発装置を使った、嫌がらせ的な攻撃は、米軍やその連合軍だけでなく、一般市民にとっても大きな脅威となり、人的被害の60%は、手榴弾や砲弾から作られるそのような爆発物によるものだったのです。

地雷探知機を搭載したハスキー-VMMDは、南アフリカに拠点を置くDCD社の鉄道車両部門が国防軍のために独自に開発した車輛です。アメリカでのテストにより、米陸軍から高い評価を得て、2007年米陸軍と海兵隊の工兵部隊に配備されたのです。それまでの地雷探知車輛との違いは、組み立て式の構成で設計されていた点です。地雷の除去作業は、ほんのわずかな圧力がかかっただけで爆発してしまいます。V字型の車体底部と高い地上高は、地雷が爆発してしまった場合の防御に有効です。車輛前後の組み立て式構成部は、爆発で吹き飛んだりした場合でも、前線での交換修理を短時間で可能にしています。ハスキー-VMMDは幅3mまでの通路を探索でき、爆発物の種類を分析し、後に続く除去専門車輛のために地雷の位置をマーキングしておくのです。ハスキー-VMMDの採用によって、多くの兵士や市民の命が救われました。特にアフガニスタンで大量に仕掛けられた即席爆破装置の効果的な除去に活躍したのです。2010年、米陸軍と海兵隊は新型のハスキー-Mk. III をテストしました。それは15kgのTNT火薬の爆発にも耐え、もし車輪の下で爆発が起きたとしても、操作員が無事であるという防御能力を持っています。このようにハスキーの採用数は増え続けており、次のバージョンの開発も積極的に進められているのです。

在1966年爆發的南非邊境戰爭中，戰事所及的安哥拉與納米比亞境內地雷被過度的濫用，地雷埋設的數量已相當於當地的人口數。為排除這些地雷的威脅，從上個世紀七十年代起，南非國防軍便逐漸累積地雷探測與清除的經驗。為提高偵測地雷的效率，車載的探雷系統也被軍方充分的運用，並證明了其能力。

進入21世紀後，美軍涉入阿富汗與伊拉克兩場戰役，由於交戰雙方在技術上存在數代的差距，對手具組織的作戰力量在傳統的攻堅戰中迅速的遭到瓦解。但反抗美軍的武裝力量選擇化整為零，以簡易爆炸裝置廣泛的進行襲擊與騷擾。此舉對美軍為首的聯軍甚至平民都形成了重大威脅，超過六成的美軍傷亡為這類以手榴彈或砲彈改裝的爆裂物所造成。

南非的RSD公司開發的「哈士奇」探雷車，原本僅是該公司獨力開發的一項產品，但在經過南非與美國本土的測試之後為美國軍方所採用，2007年後陸續的進入陸軍與陸戰隊的工兵單位中。「哈士奇」有別於早期的探雷車而採用模組化設計，極低的接地壓力讓車輛通過地雷上方時不易引爆。即便引爆，V字型的車底與較長的離地距離將有效的降低爆炸的損害。前輪與後輪組件也能夠在受損後迅速在野戰條件下更換。「哈士奇」能夠偵測寬度達三公尺的道路，並能分析爆炸物的類型，在經過標示後由後續模組車輛加以排除。「哈士奇」在投入使用後無形中已挽救了大量軍人以及平民的生命，特別是在有大量簡易爆炸裝置埋藏於地下的阿富汗。2010年，美國陸軍與陸戰隊再對新開發的「哈士奇」Mk III型進行15公斤級的TNT炸藥測試。測試證實即便在車輪處爆炸仍未對乘員造成傷害，因此增加了對「哈士奇」的採購數量，並積極進行後續車款的開發。

### Illustration: 圖示說明



### Method For Applying Decals:

1. Clean Model Surface With Wet Cloth.
2. Cut Out Of Decal Sheet And Dip Them In Warm Water For 15 Second.
3. Place it on proper position on Model.
4. Slide off base paper leaving decals On Model With Wet Finger Tip.
5. Move Decals To Exact Position, Push Out Excess Water Under Decal With Soft Cotton Cloth.
6. When Decals Get Dry Then Complete.

### 水貼紙使用說明:

1. 將模型表面擦乾淨
2. 將貼紙剪下泡入溫水中浸泡約15秒
3. 將泡濕之貼紙取出置於欲貼處旁
4. 用指尖輕推貼紙表面使其滑出底紙
5. 將貼紙調整至適當位置並輕擦拭水份
6. 待其自然乾燥後即完成

### Color list: 塗料表

Color	Brand	GSI Creos			Humbrol	AV Vallejo	Lifecolor
		Hobby Color	Mr.Color	Mr.Color Spray			
Bright blue	寶藍	H15	C65	S65	14	70841	LC60
Clear green	透明綠	H94				70936	
Field green	原野綠	H340	C340		105	71093	UF02
Flat red	消光紅	H13			73	70957	LC06
Flat white	消光白	H11	C62	S62	34	70919	LC01
Light gray	淺灰	H338	C338		147	71276	UA23
Orange	橘	H14	C59		18	70956	LC55
Red	紅	H3	C3	S3	19	70926	LC56
Silver	銀	H8	C8	S8	11	70997	LC74
Tire black	輪胎黑	H77	C137		85	70950	LC02
White	白	H1	C1	S1	22	70842	LC51
Yellow	黃	H4	C4	S4	69	70953	LC53
Yellow FS33531	黃	H313	C313		121	71327	DR05
Yellow green	黃綠	H16	C64		38	70954	FS09

1

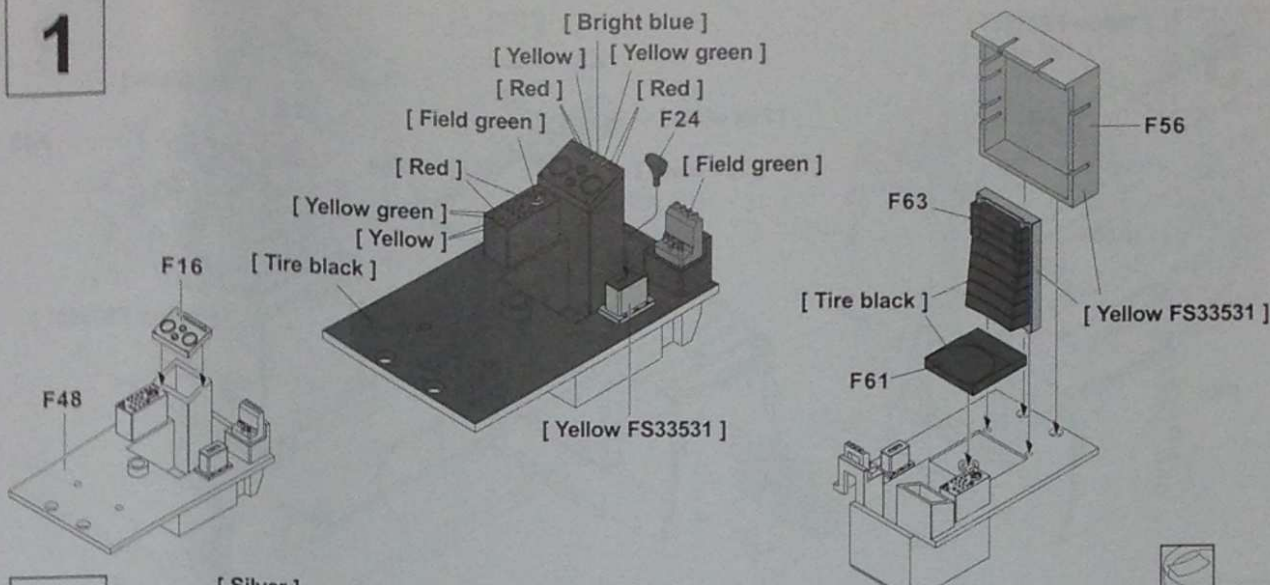

2

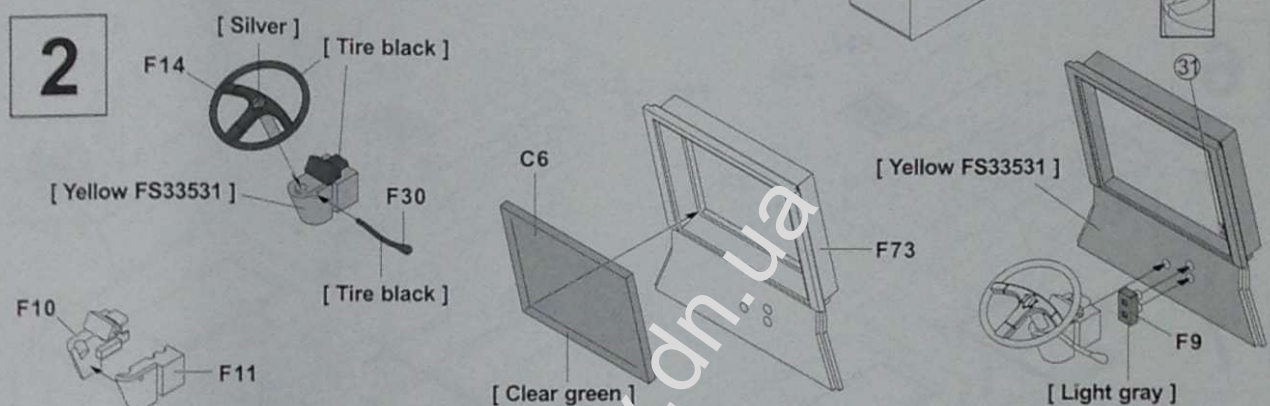

3

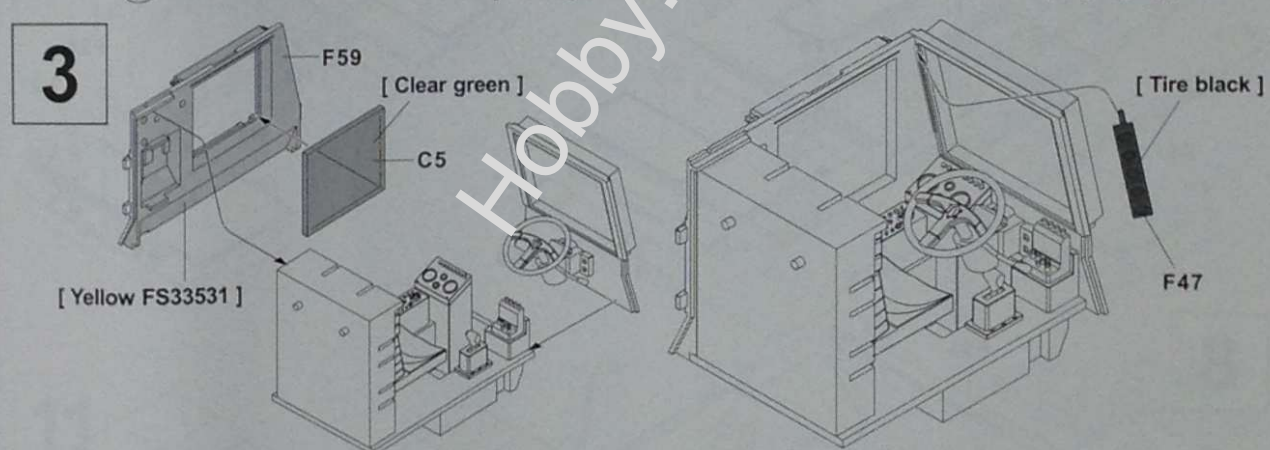

4

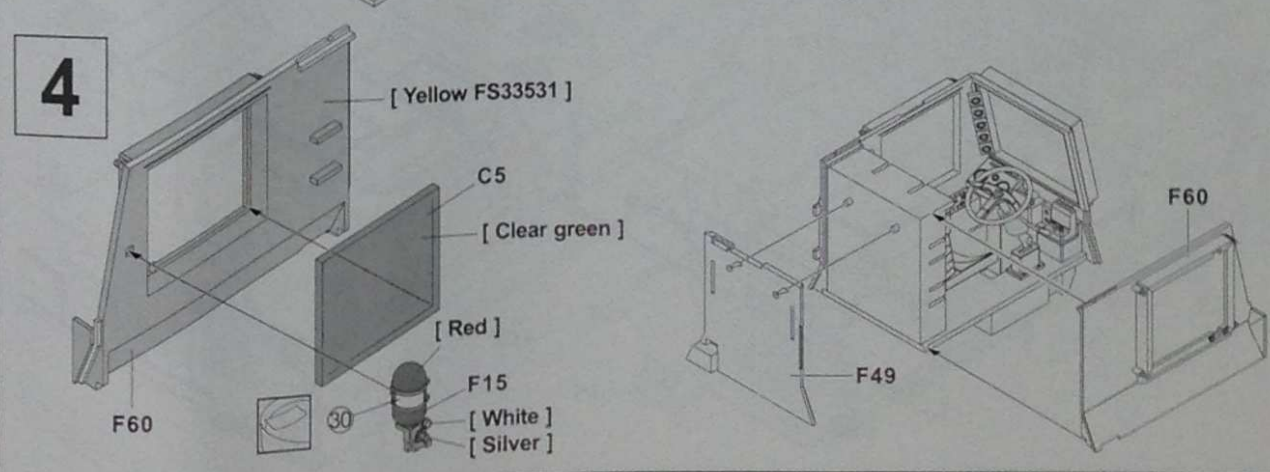

5

[ Yellow FS33531 ]  
[ Tire black ]

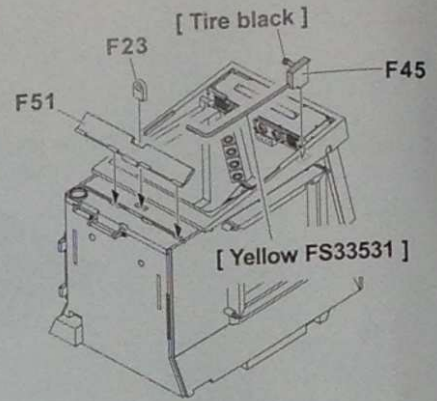
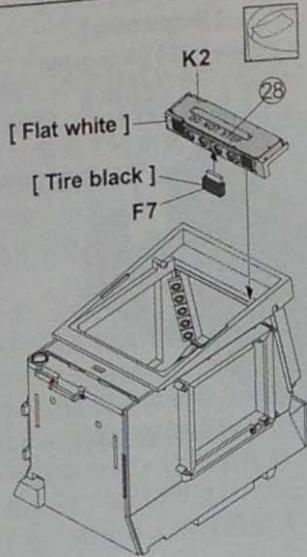
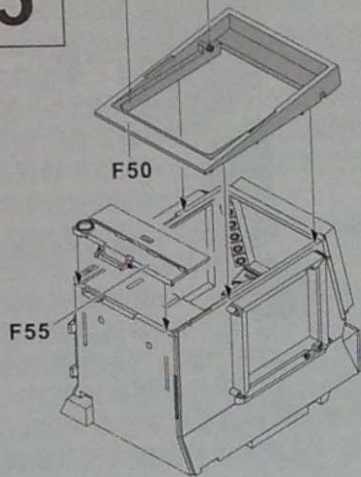

6

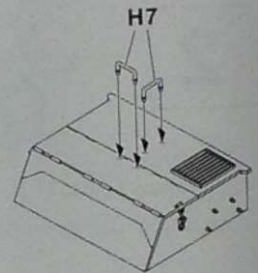
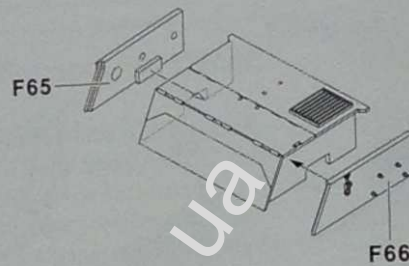
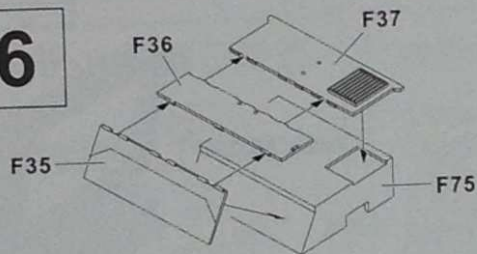

7

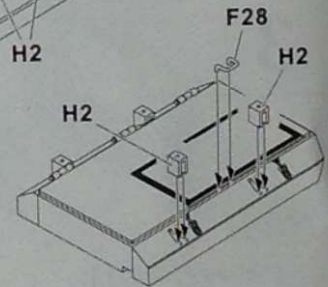
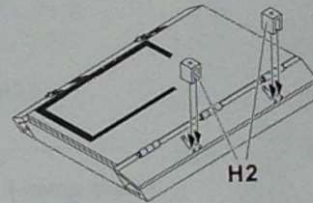
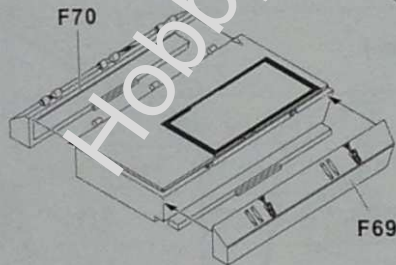
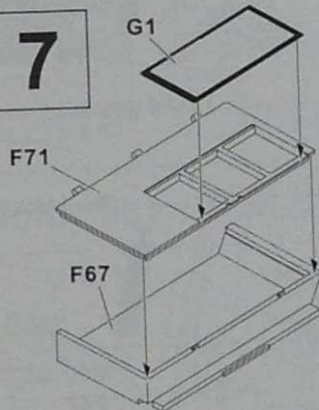

8

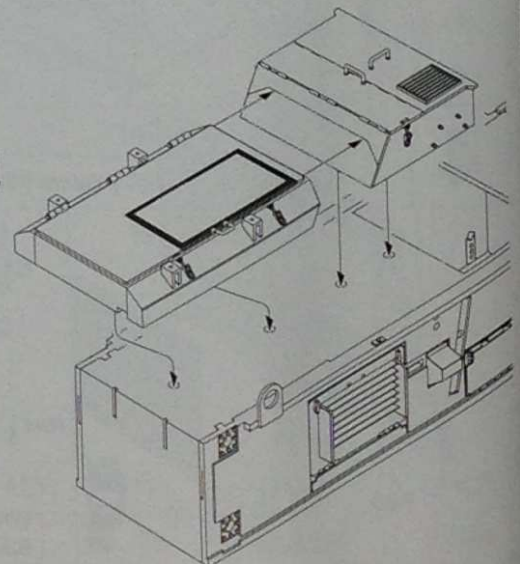
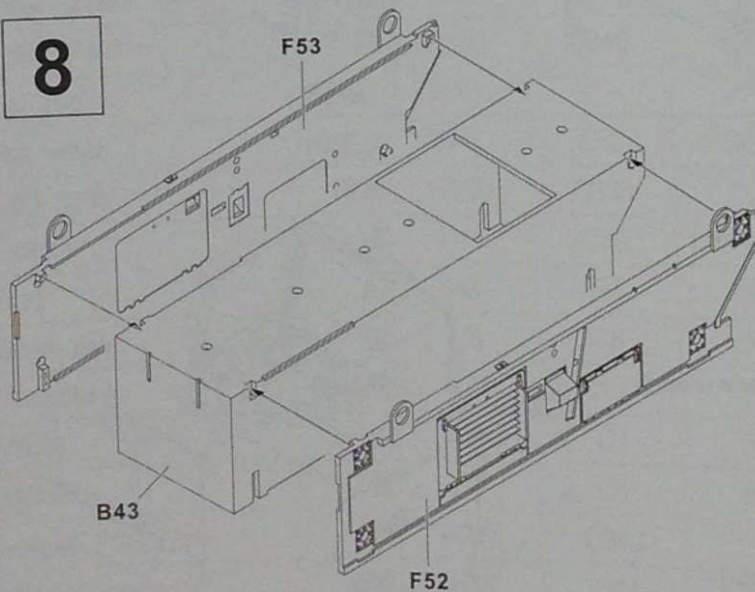

9

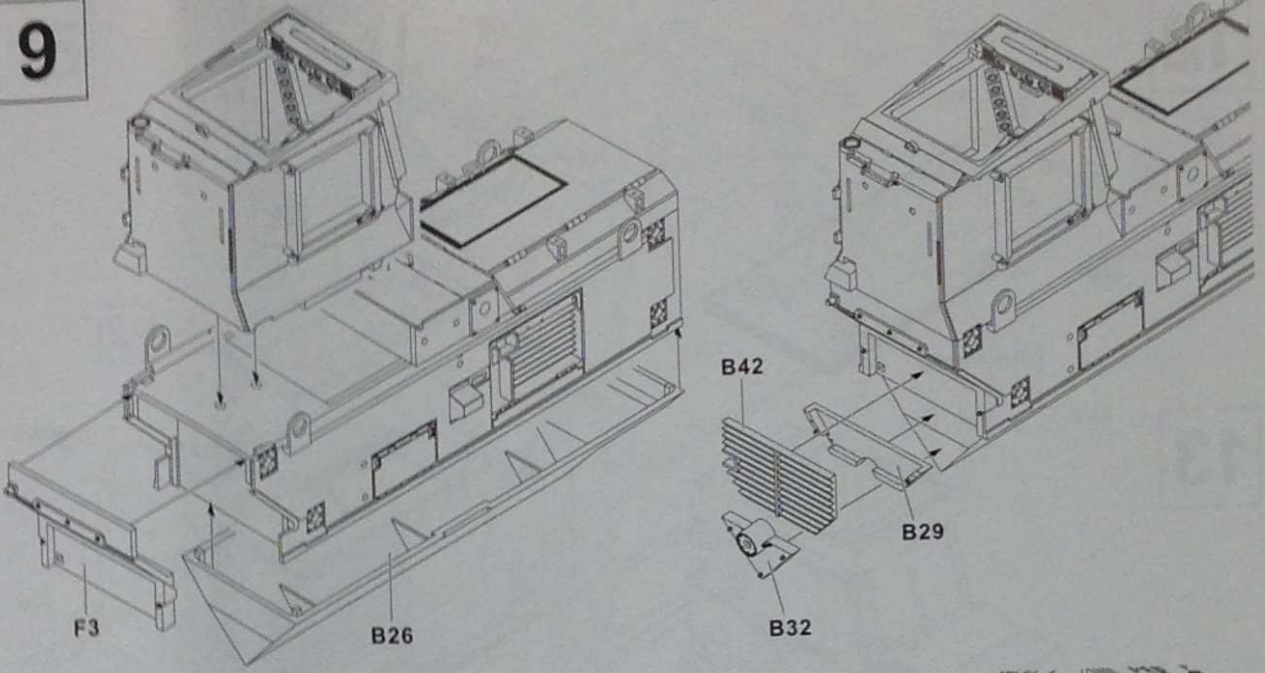

10

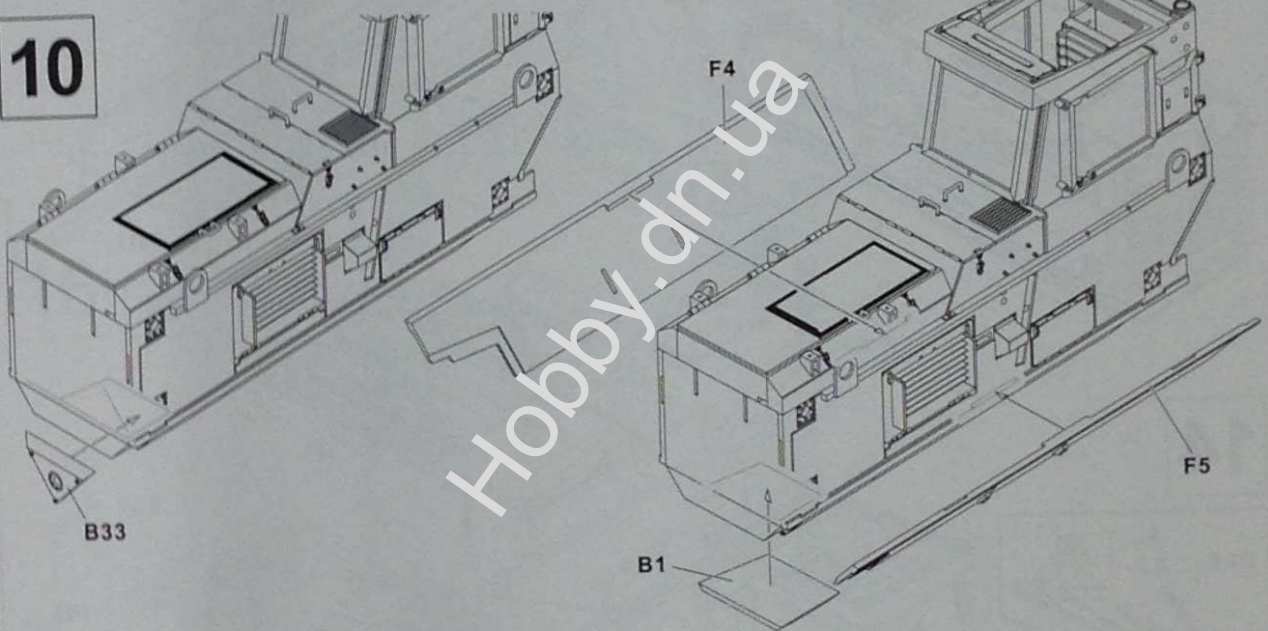

11

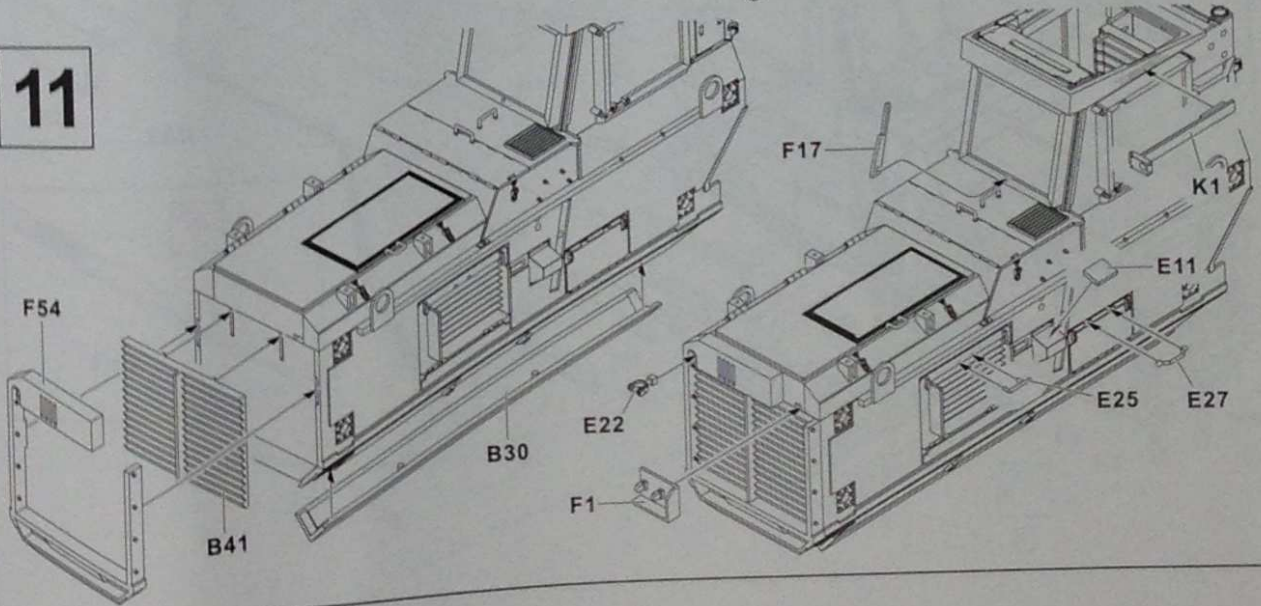

12

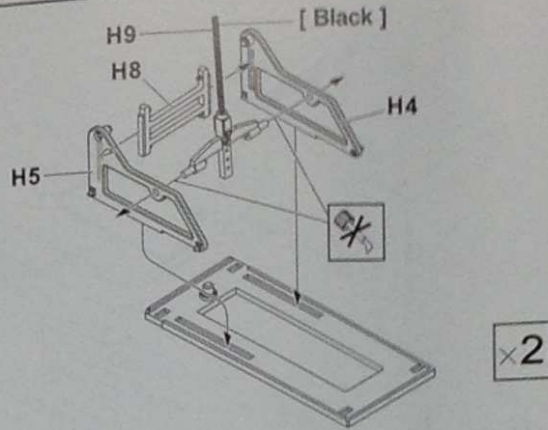
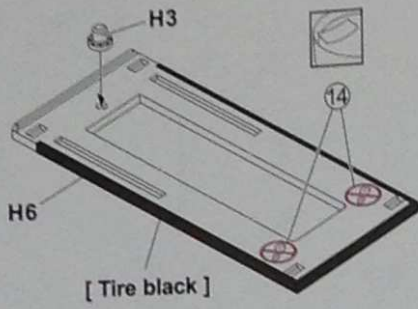

13

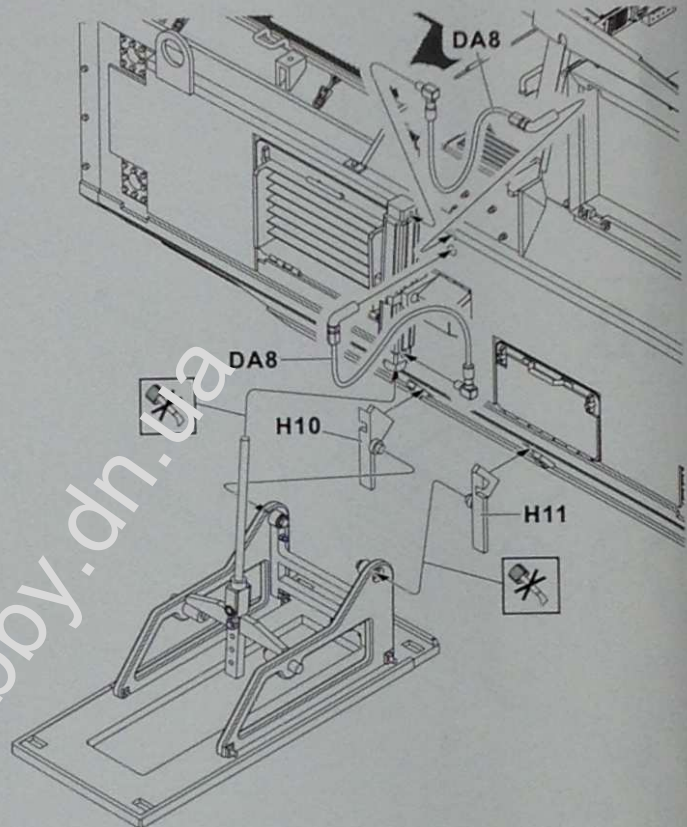
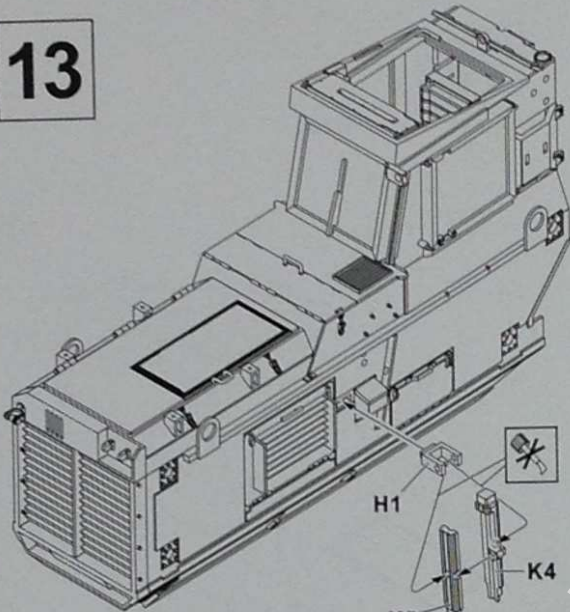

14

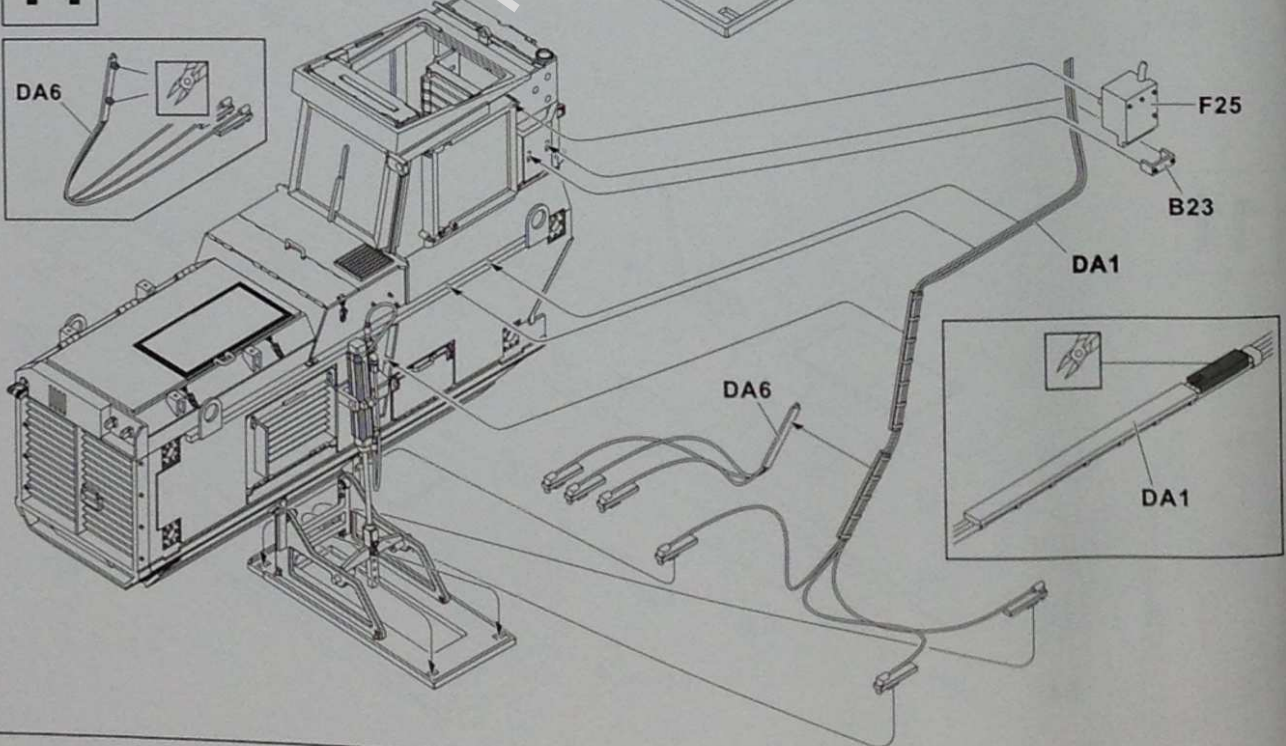
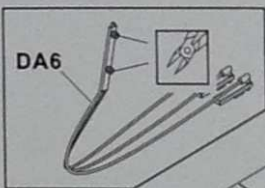

15

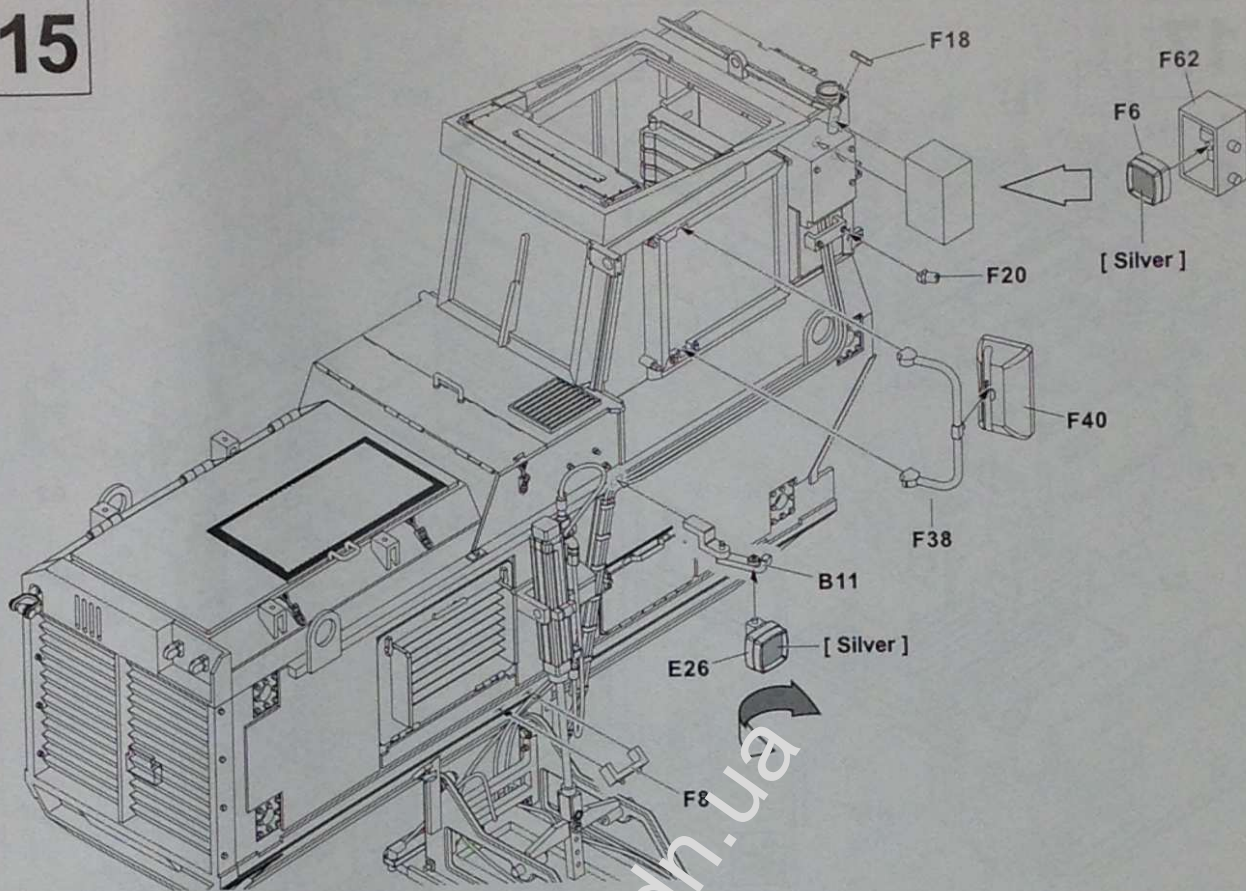

16

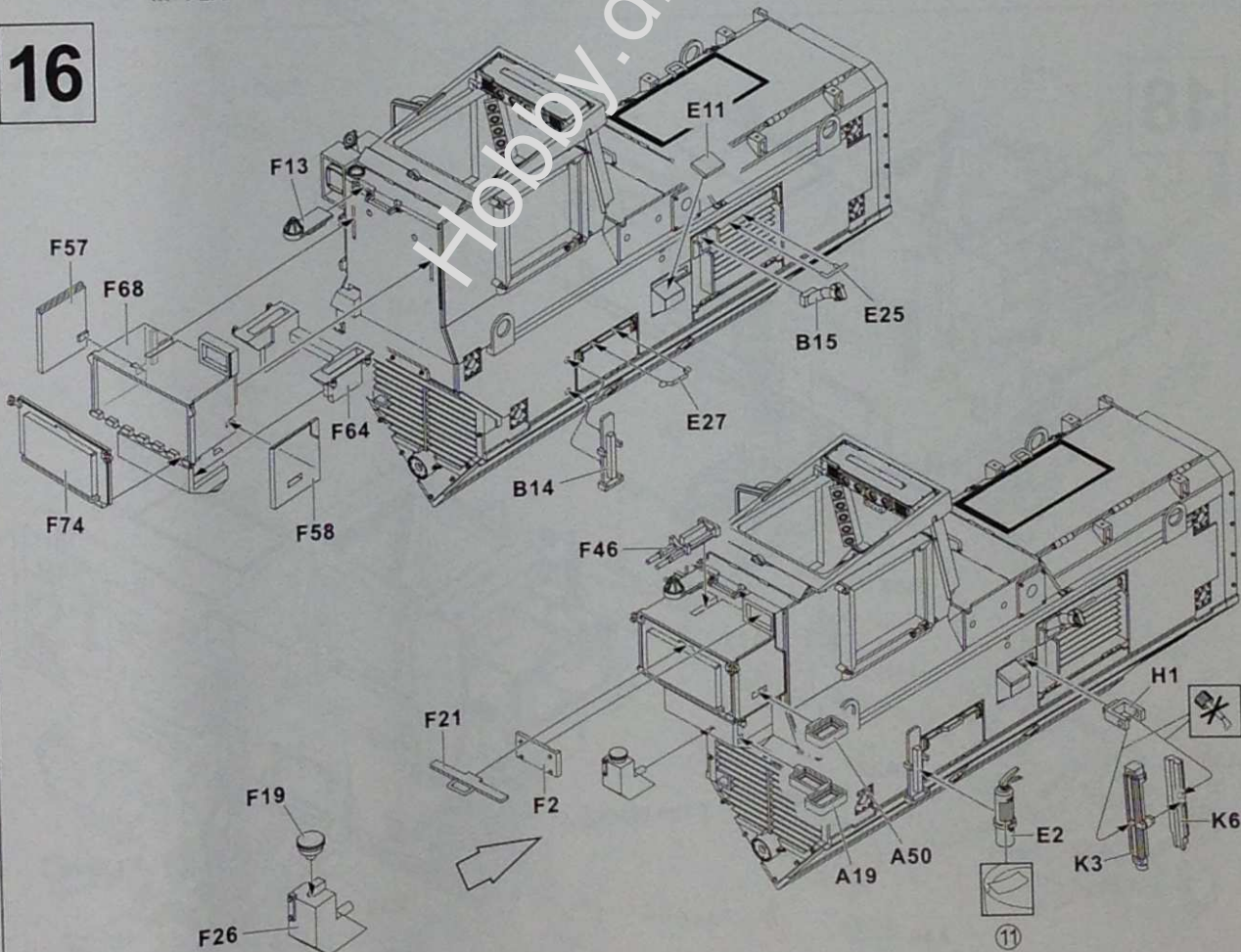

17

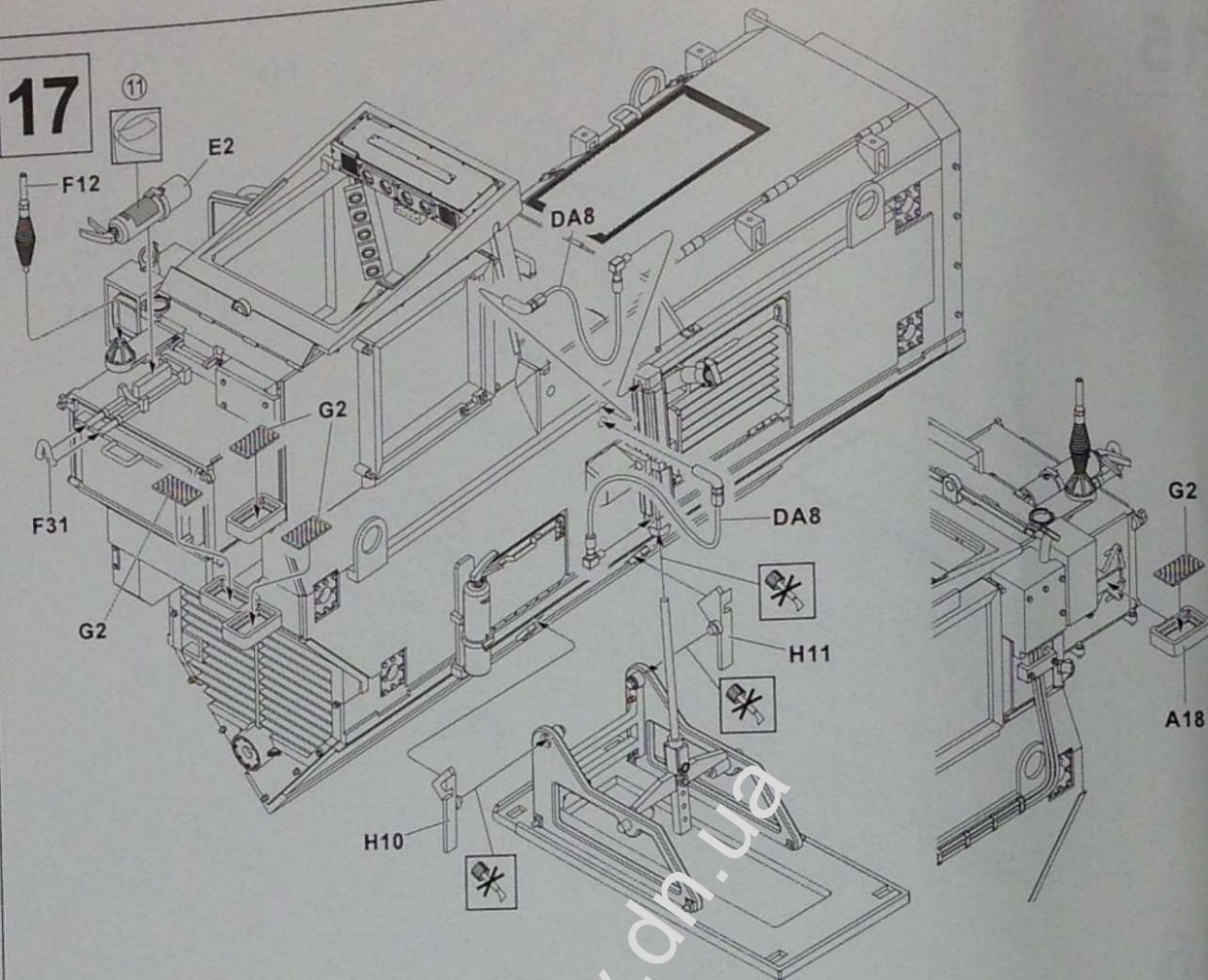

18

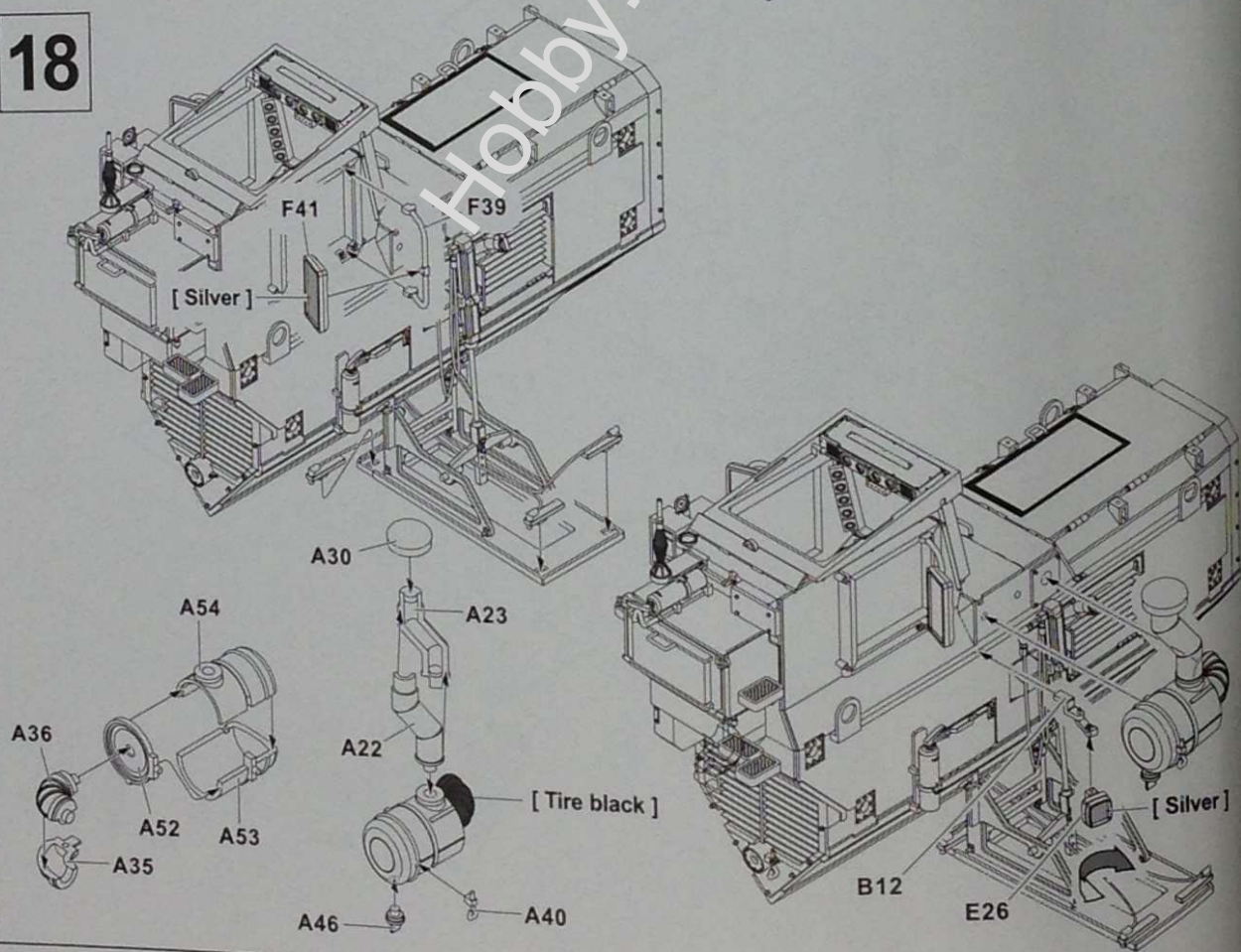



19

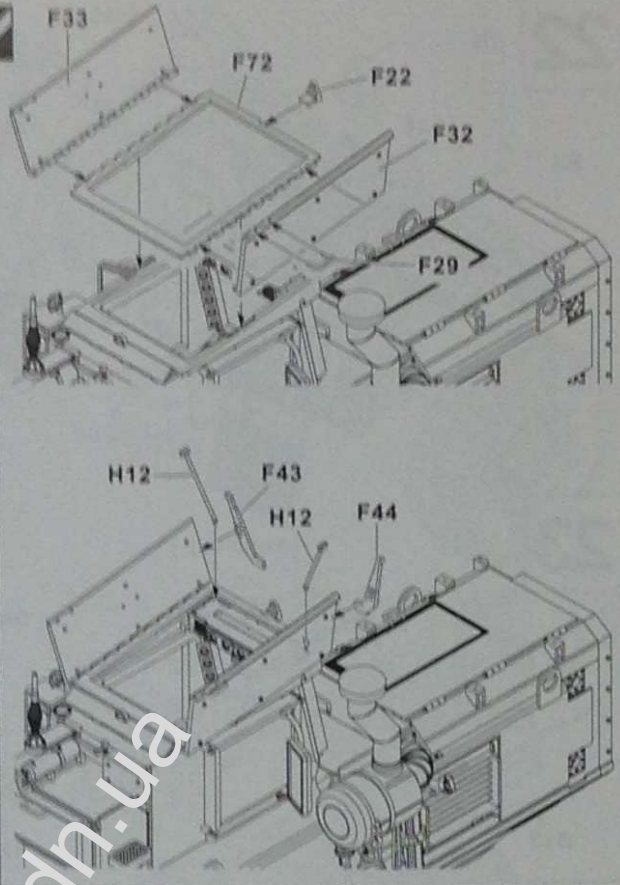
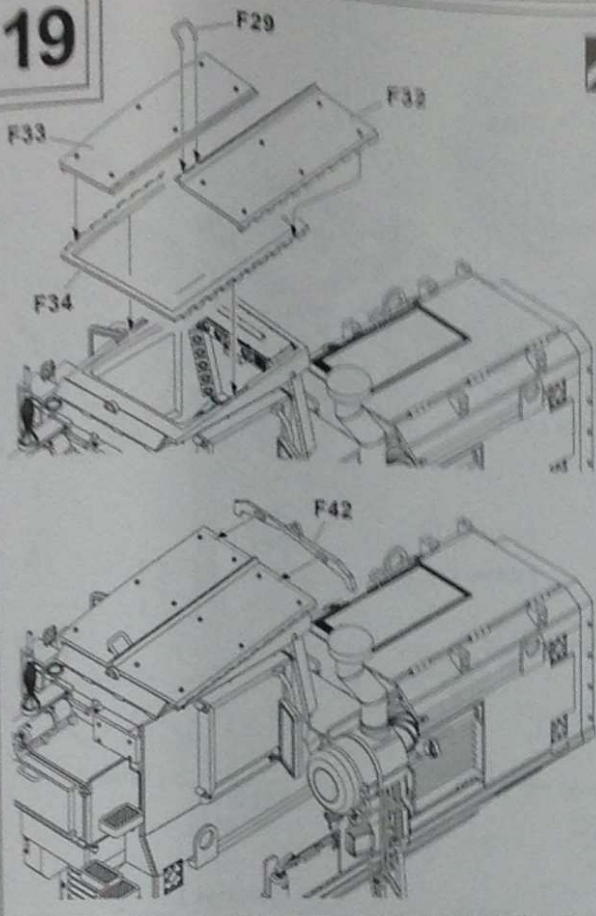

20

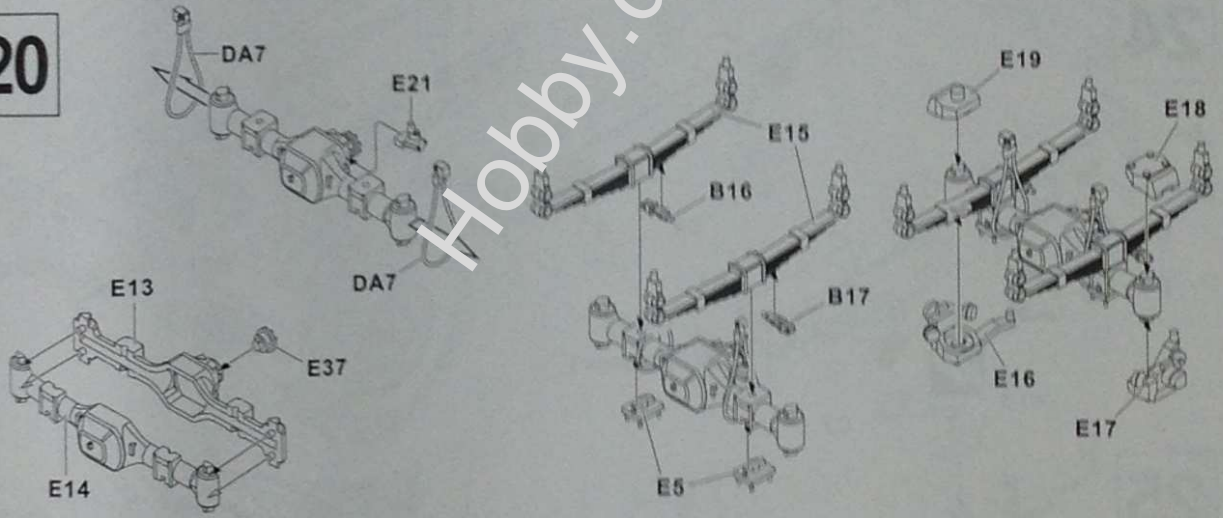

21

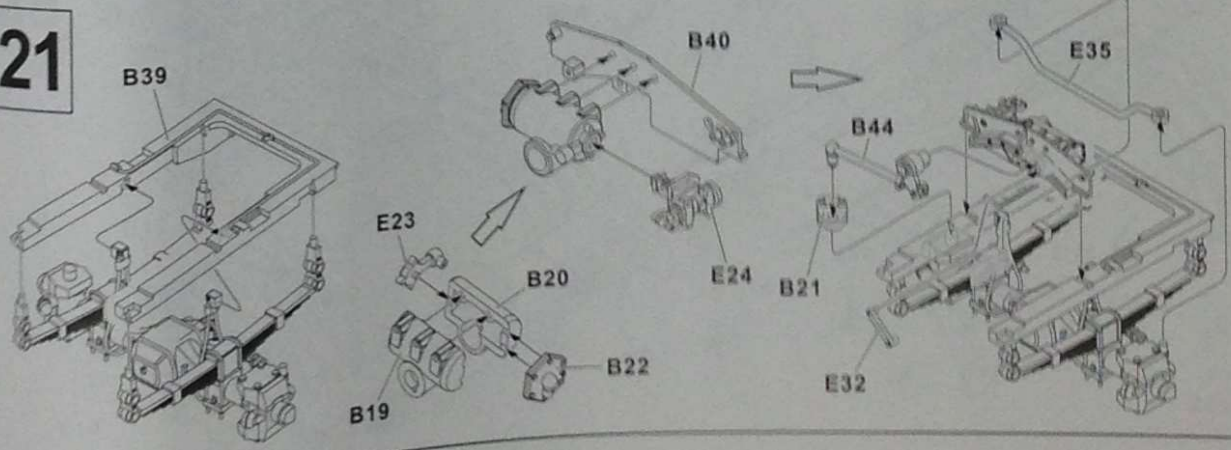

22

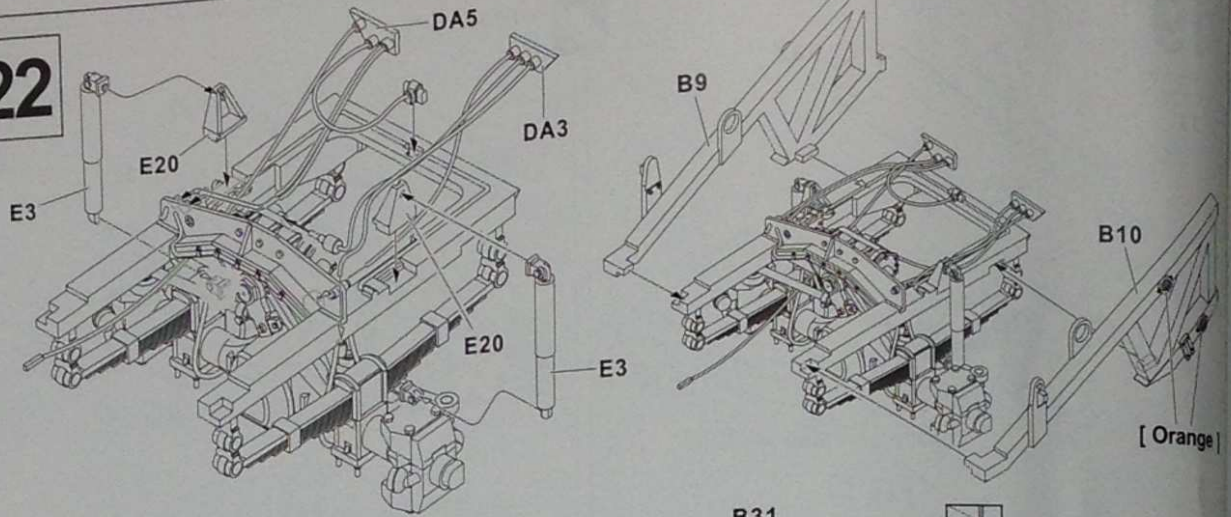

23

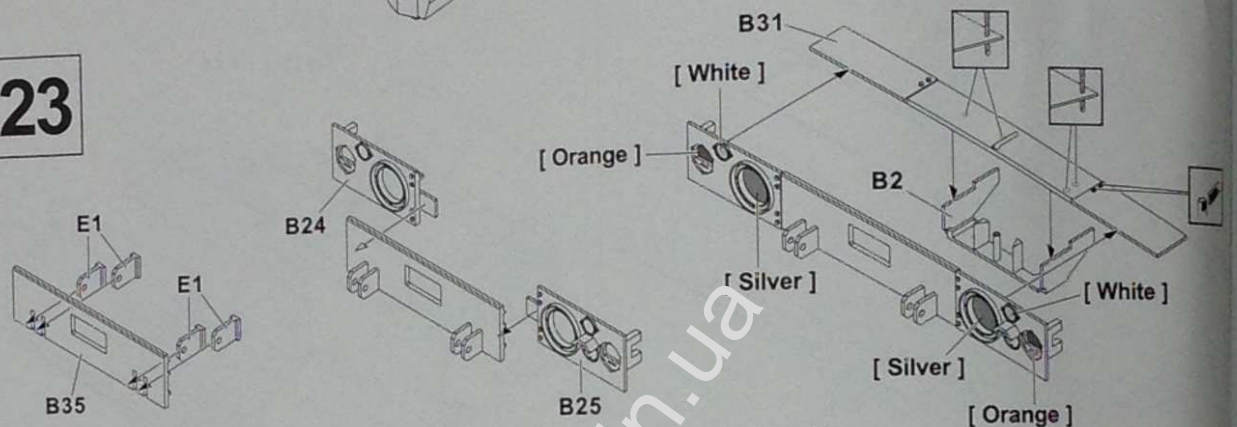

24

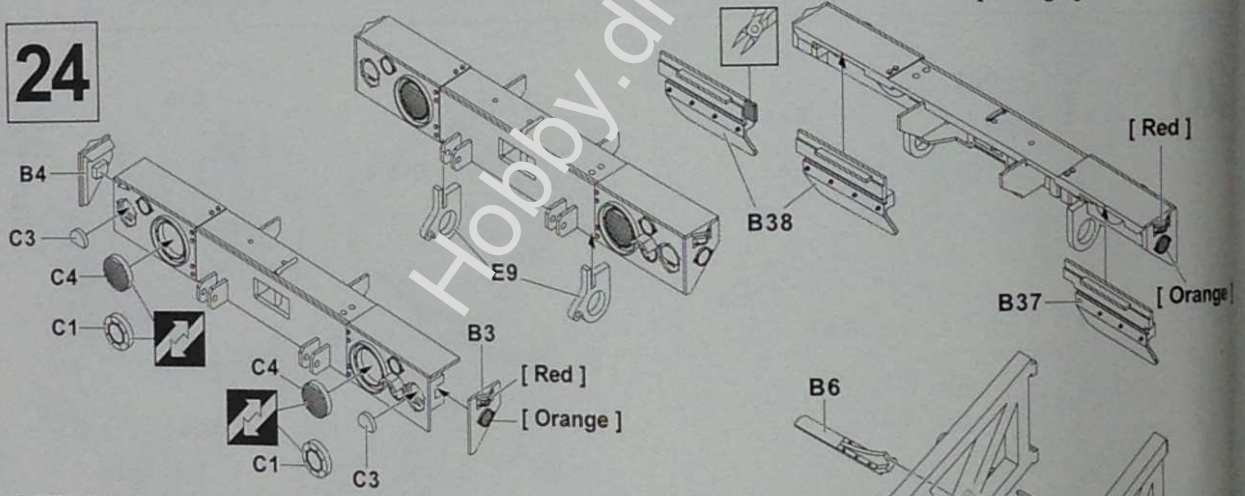

25

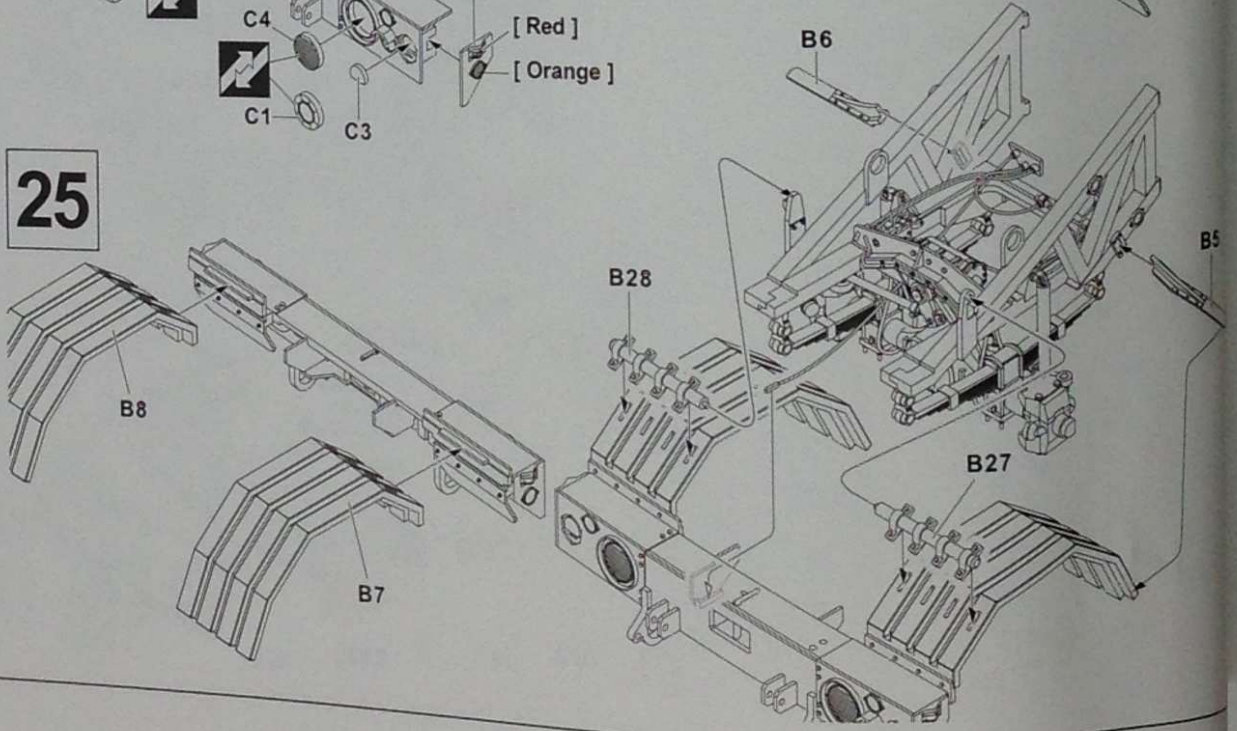

26

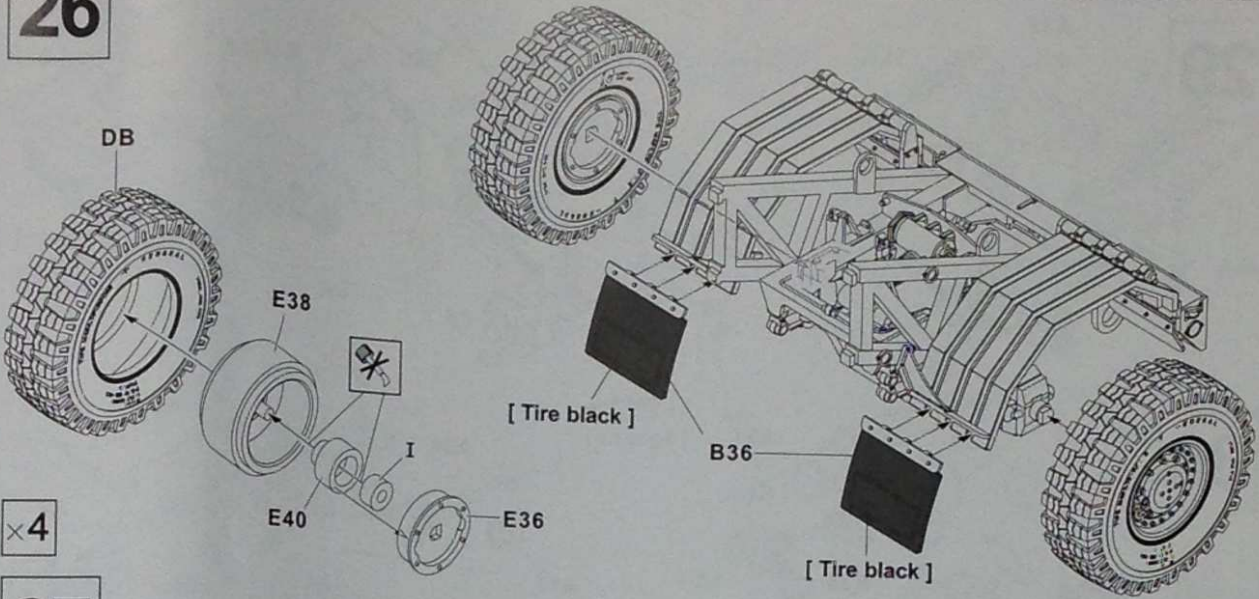

×4

27

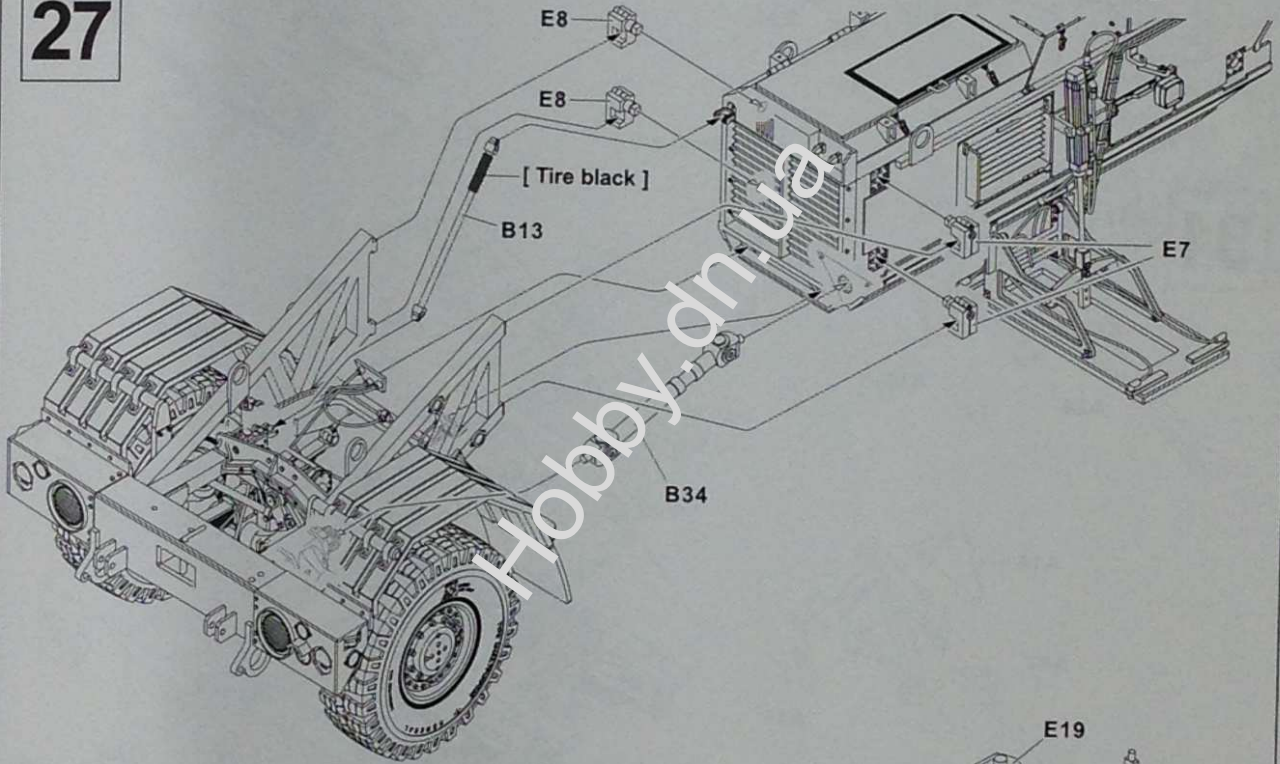

28

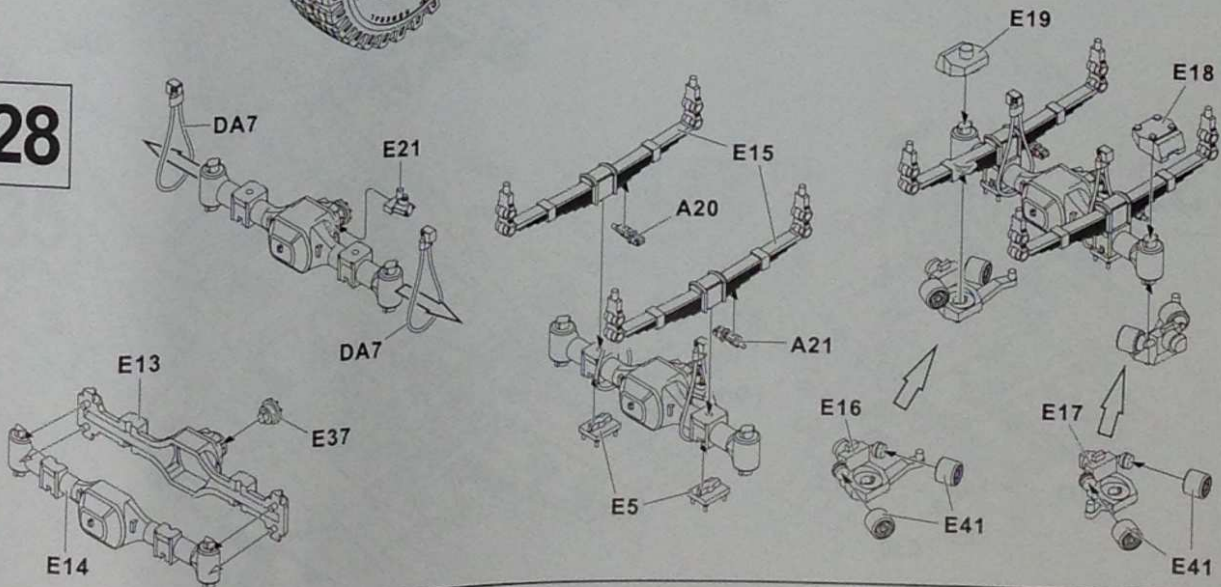

29

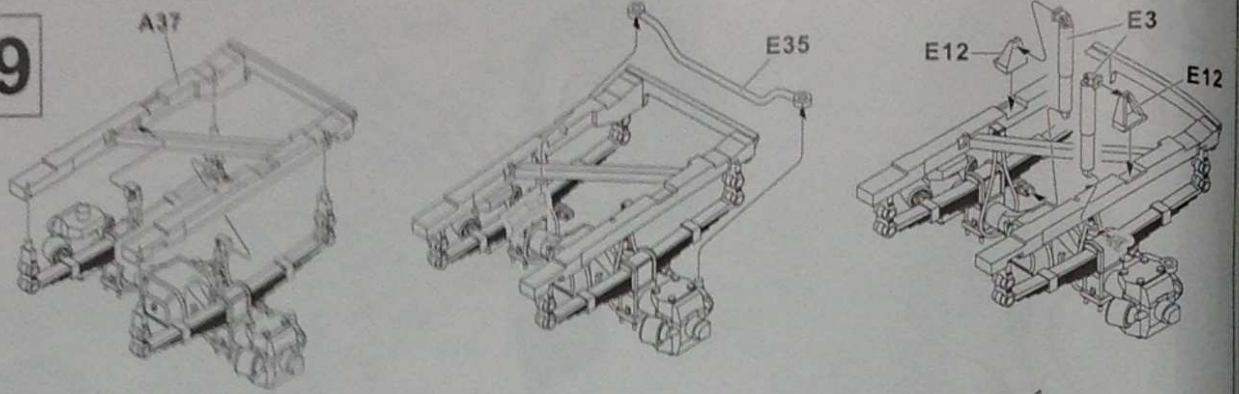

30

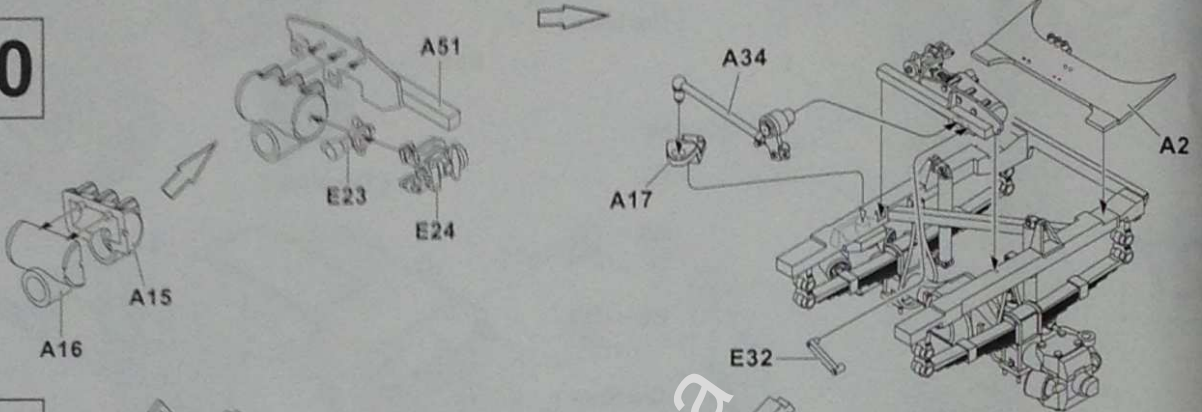

31

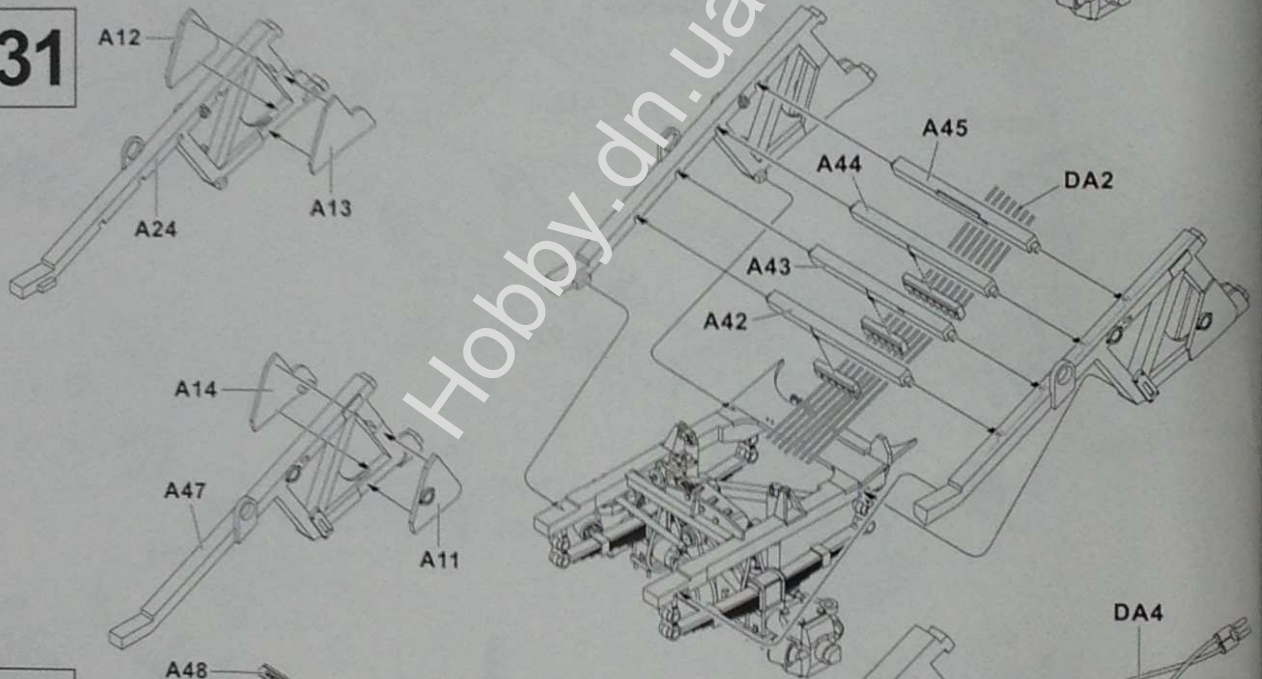

32

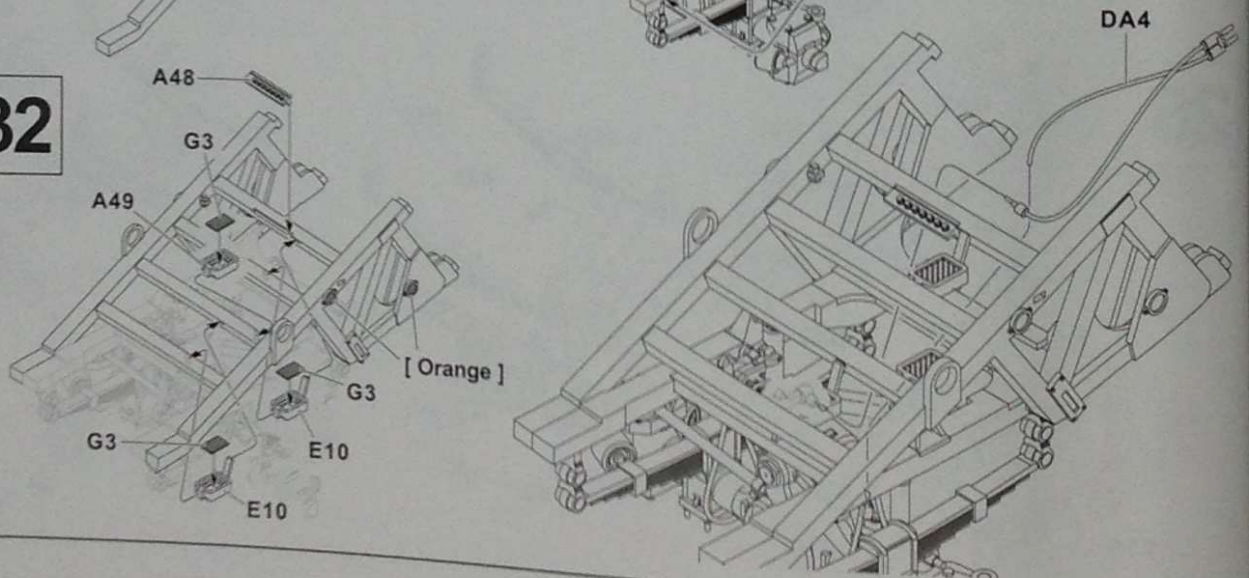

Hobby.dn.ua

33

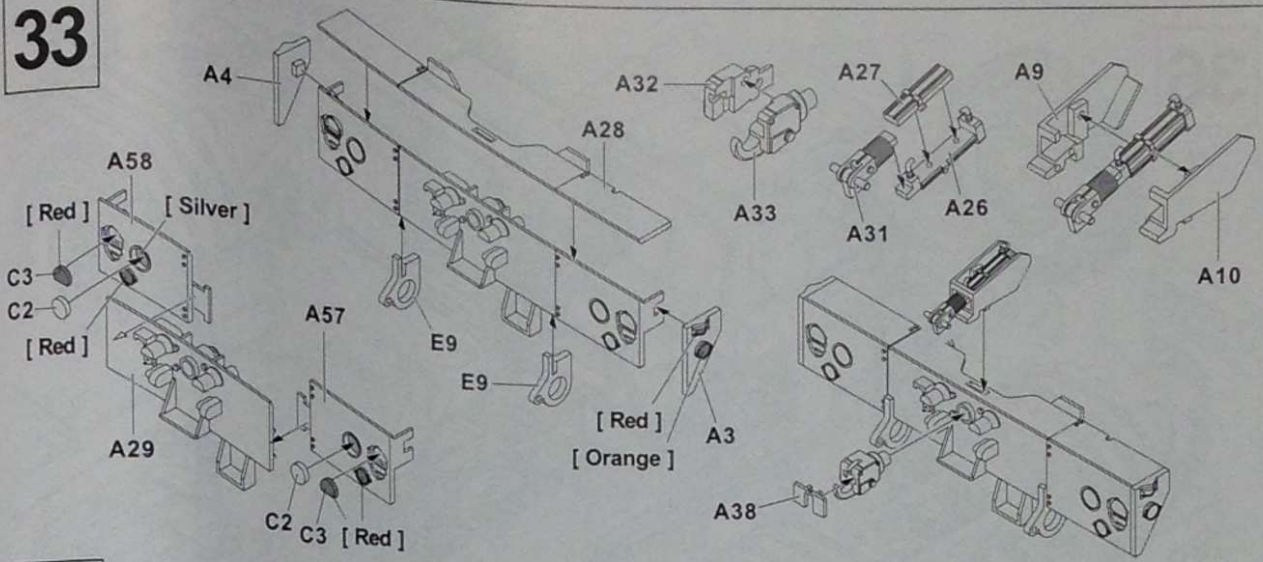

34

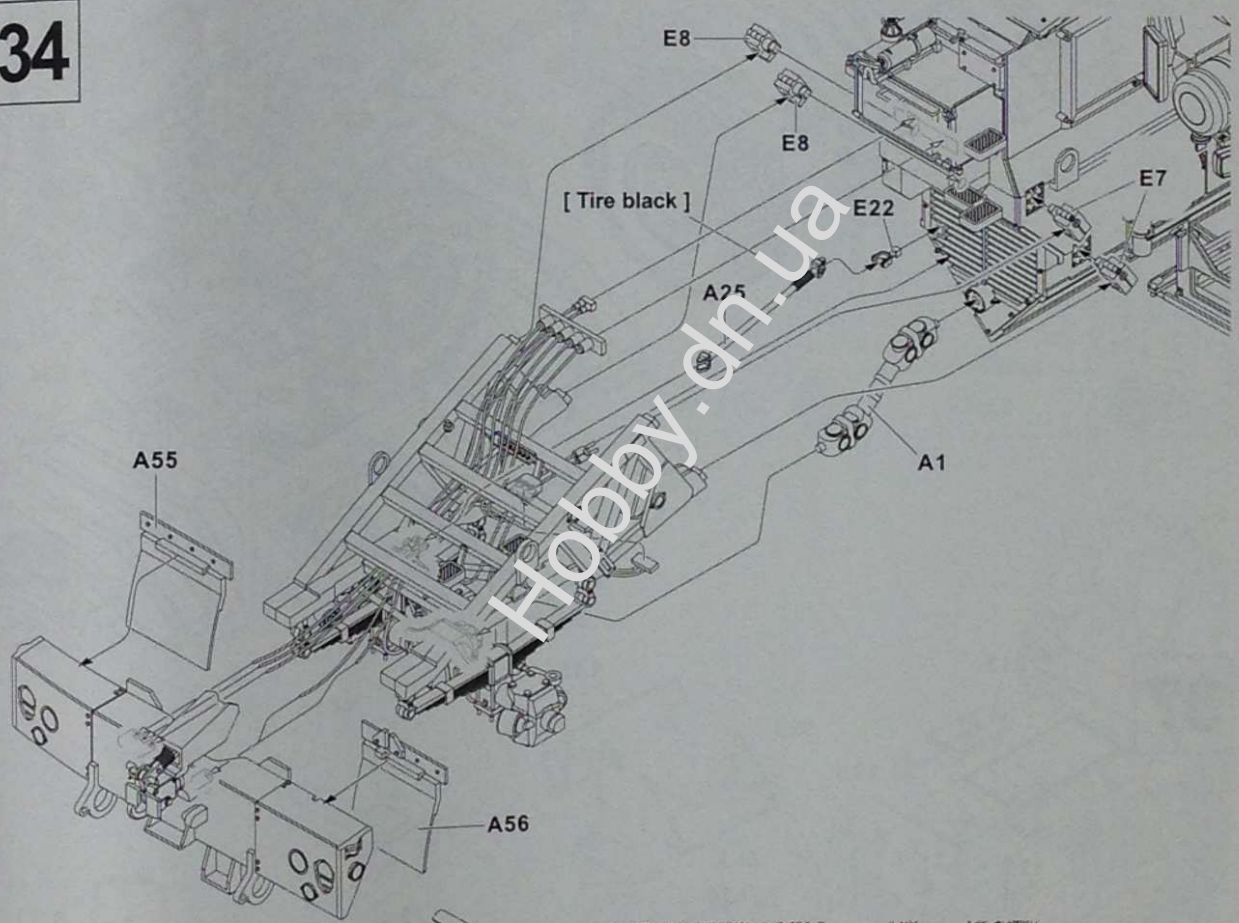

35

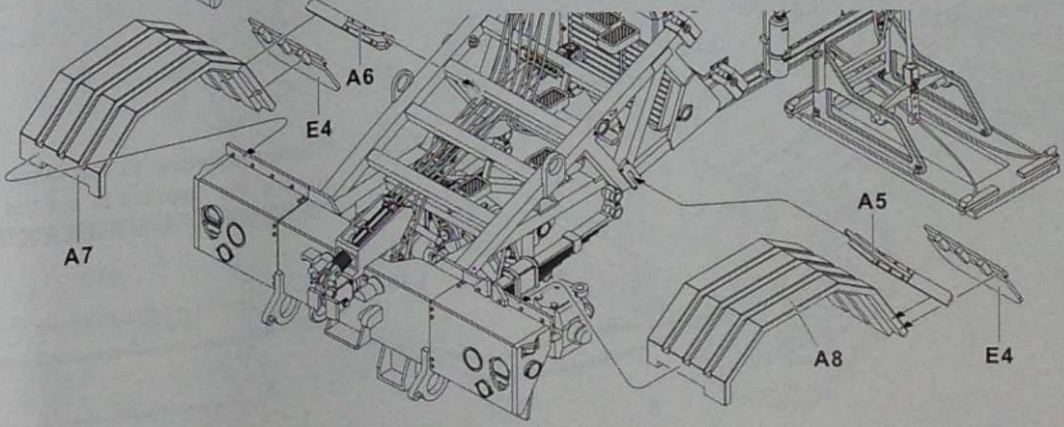

36

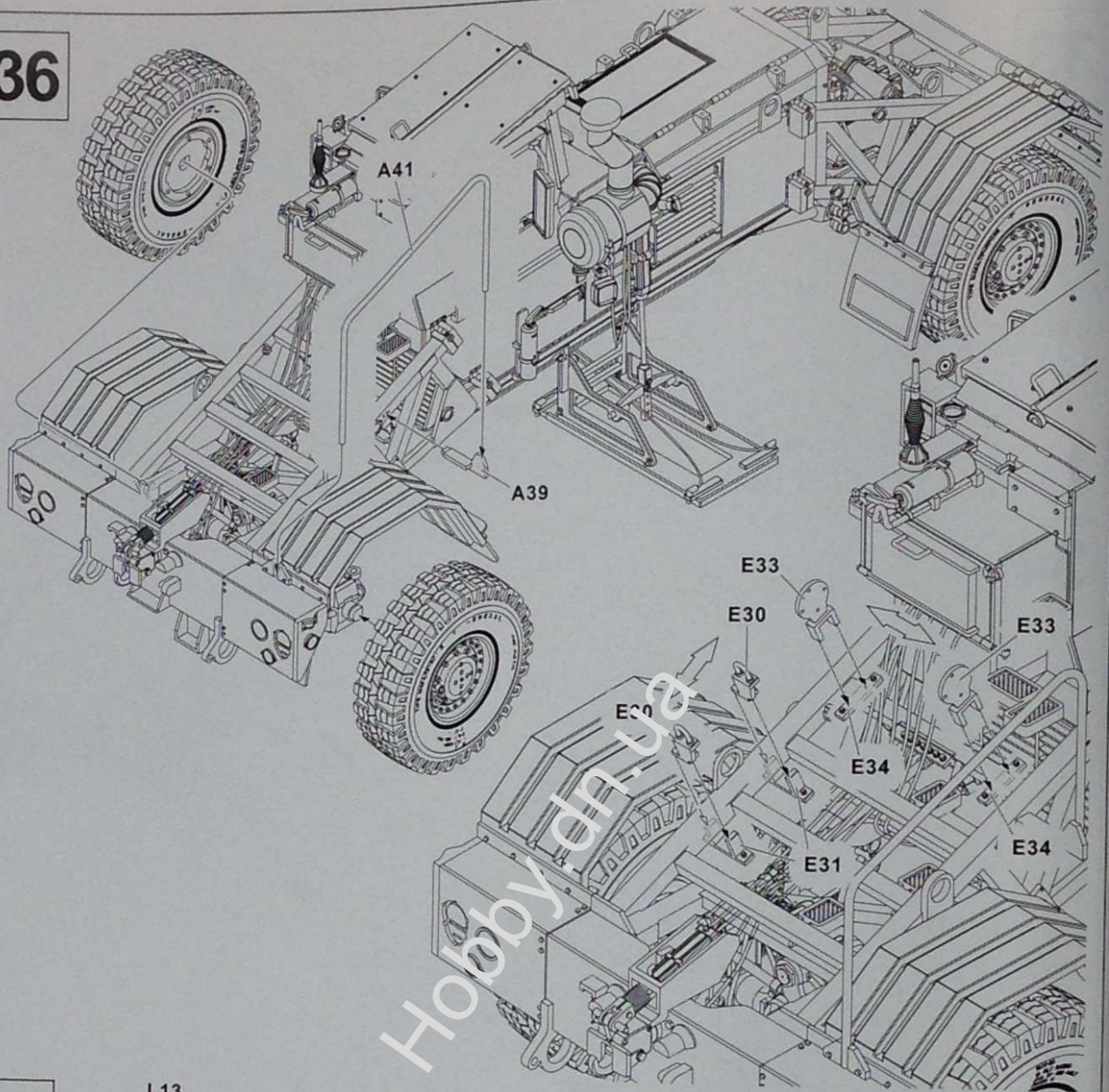

37

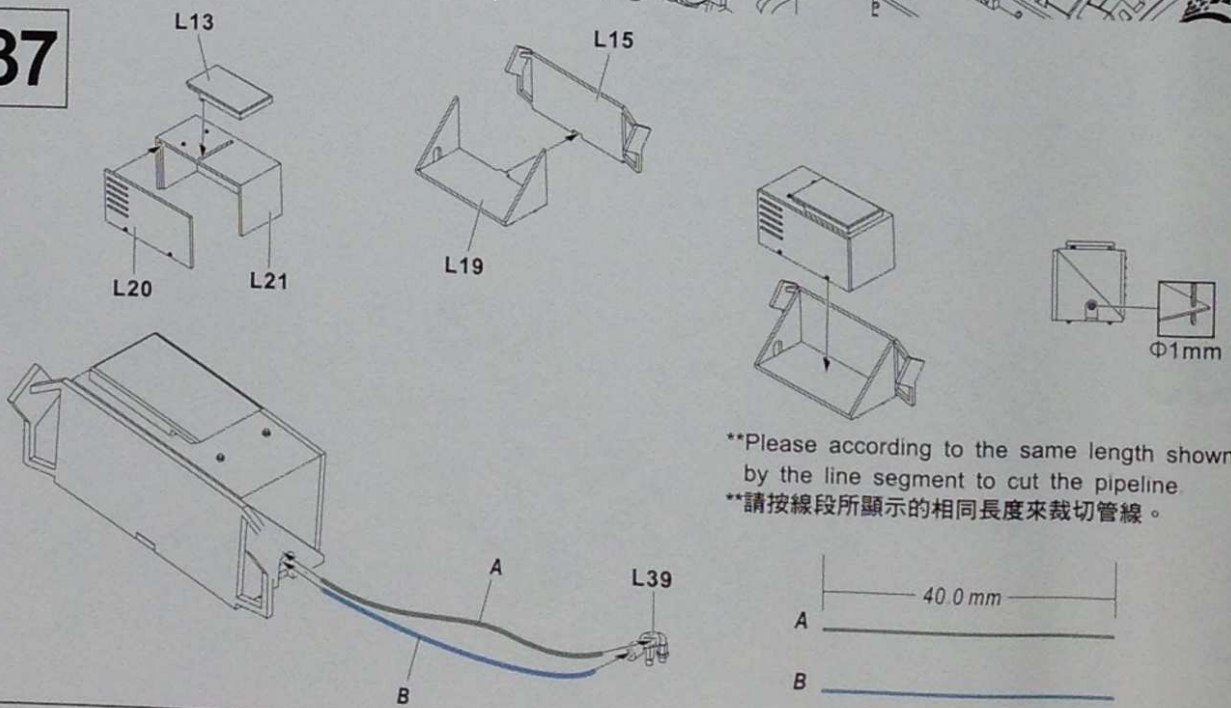

\*\*Please according to the same length shown by the line segment to cut the pipeline.  
 \*\*請按線段所顯示的相同長度來裁切管線。

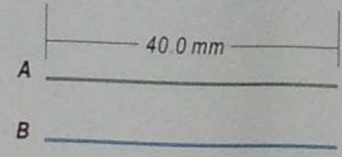

38

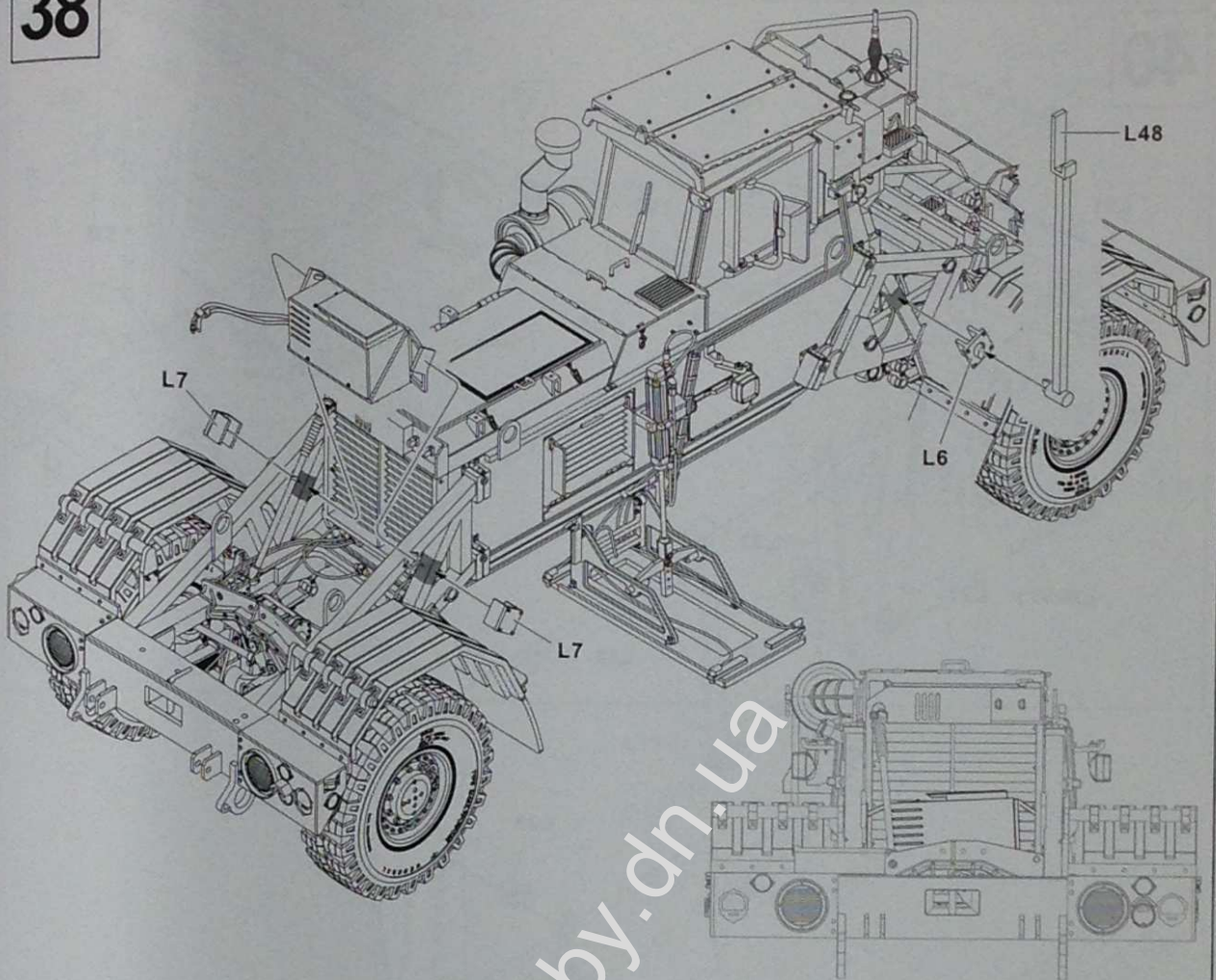

39

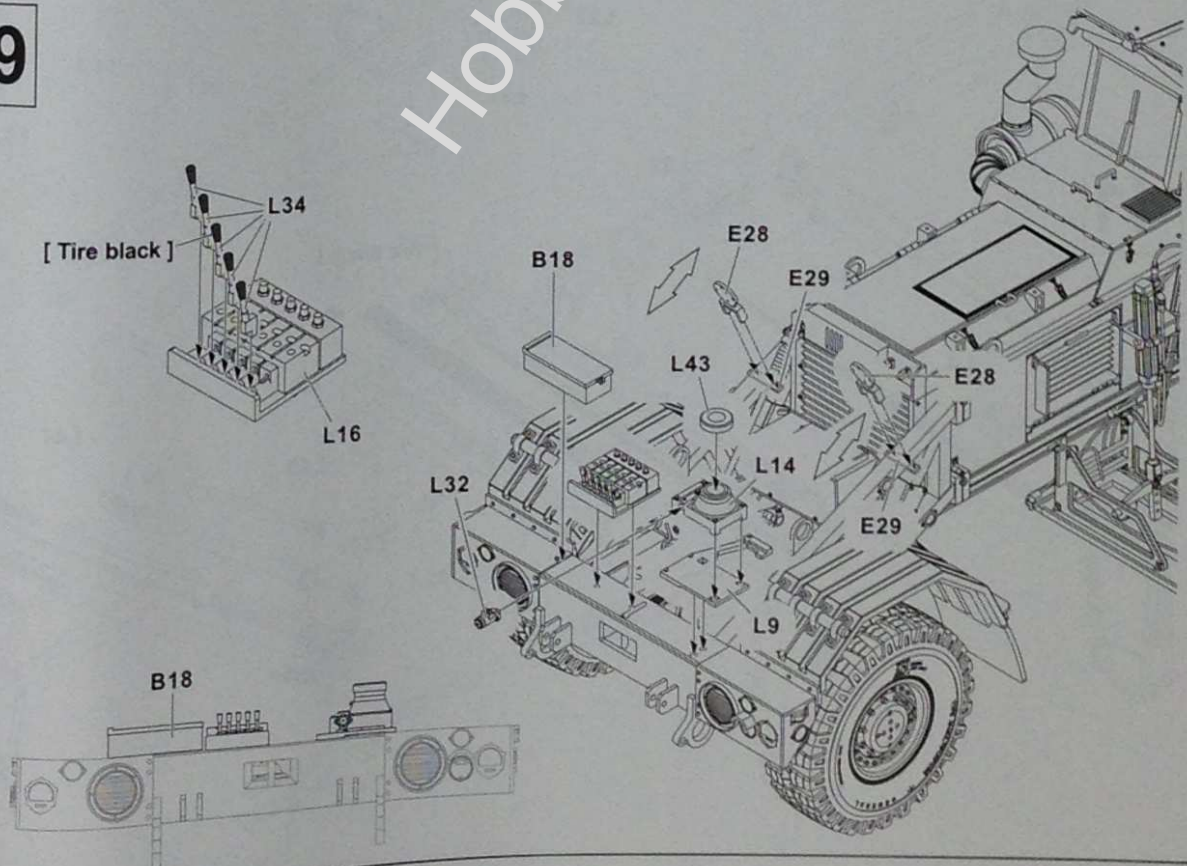

40

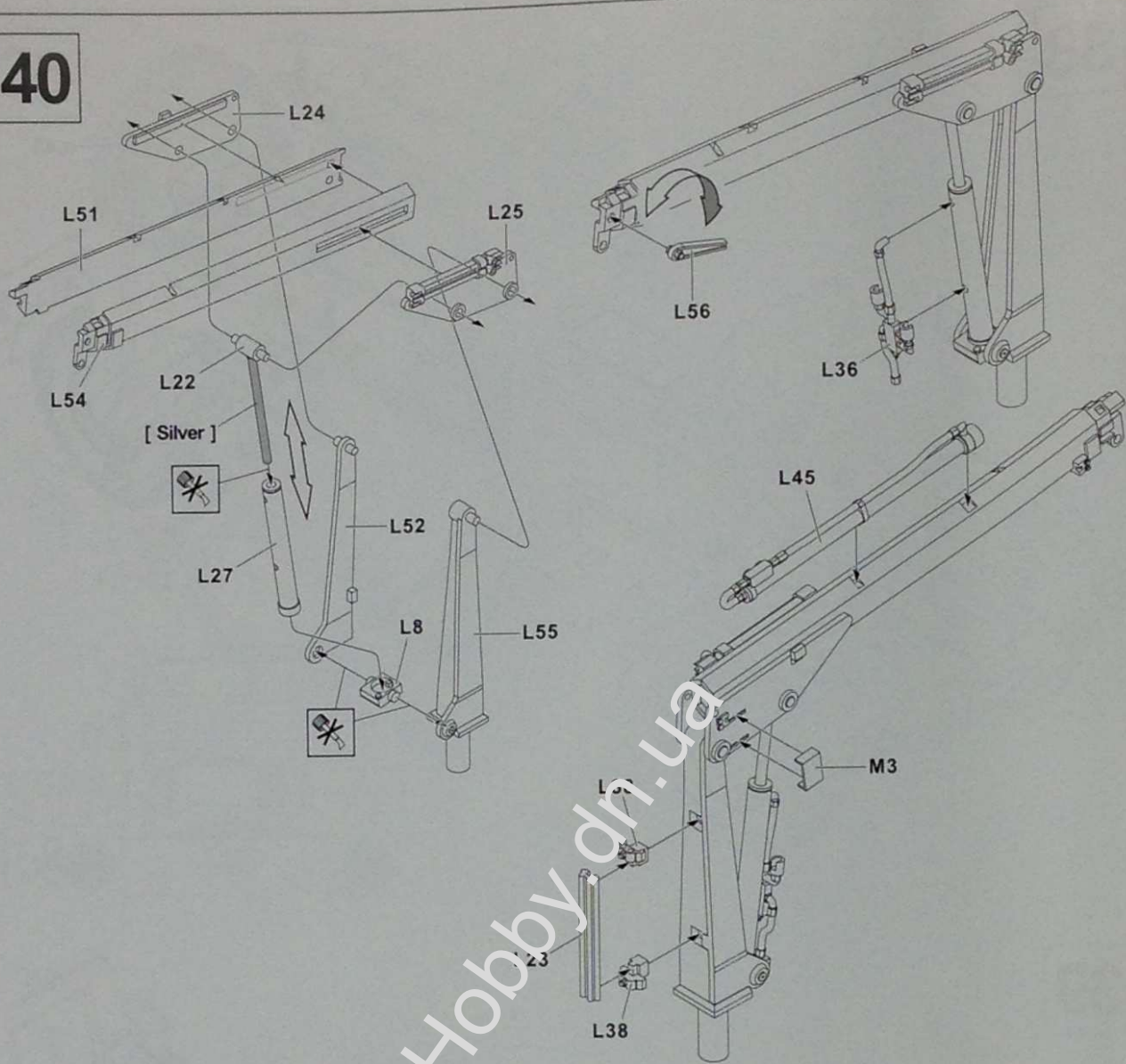

41

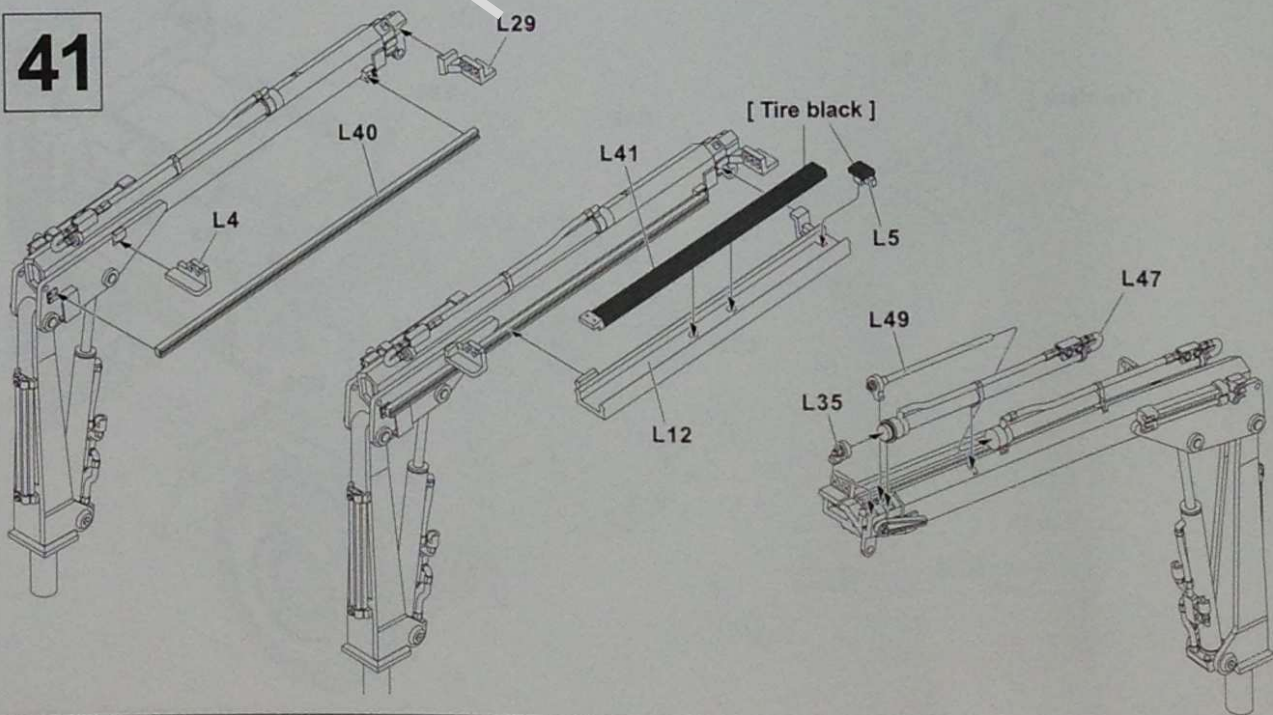



42

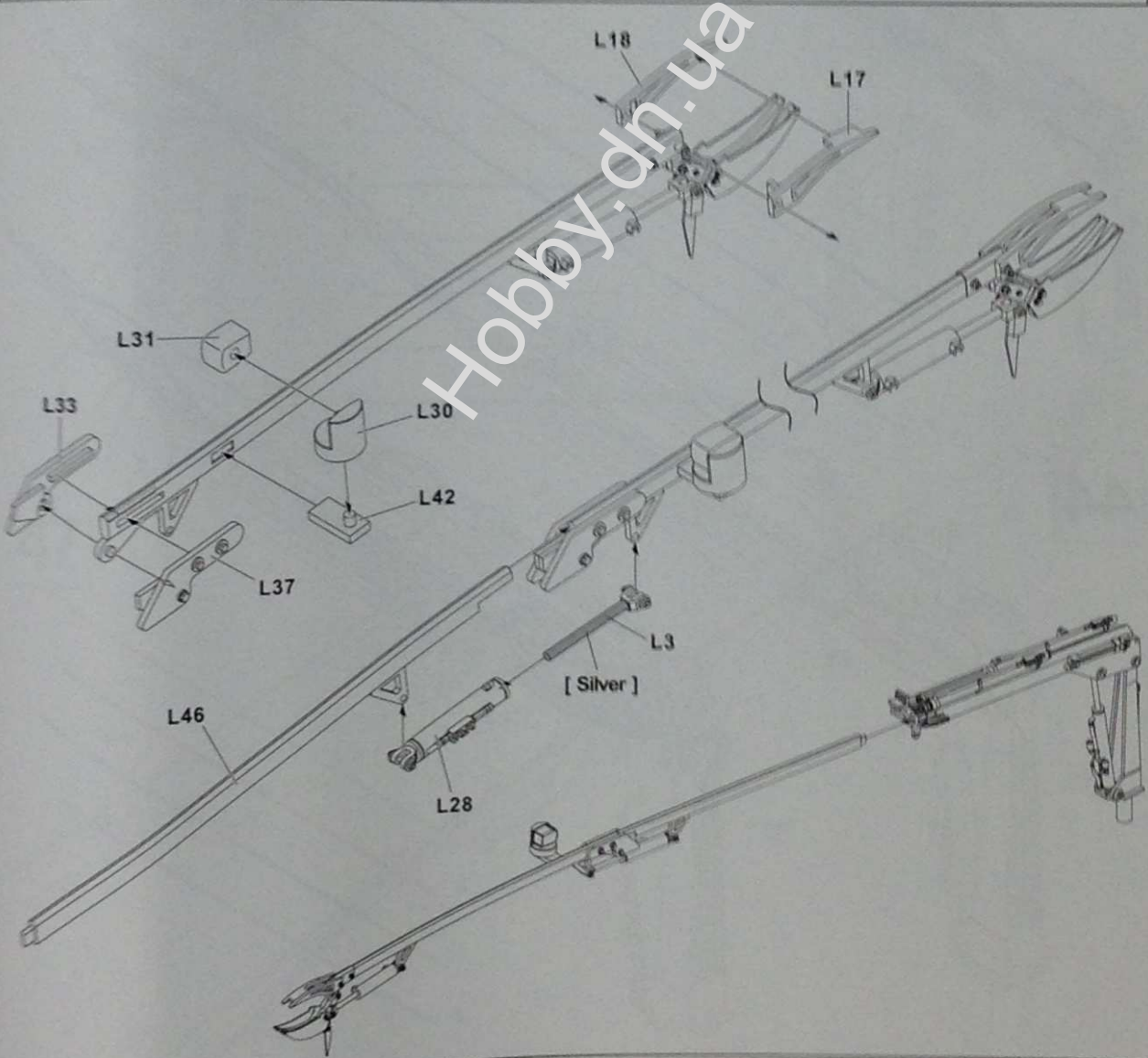
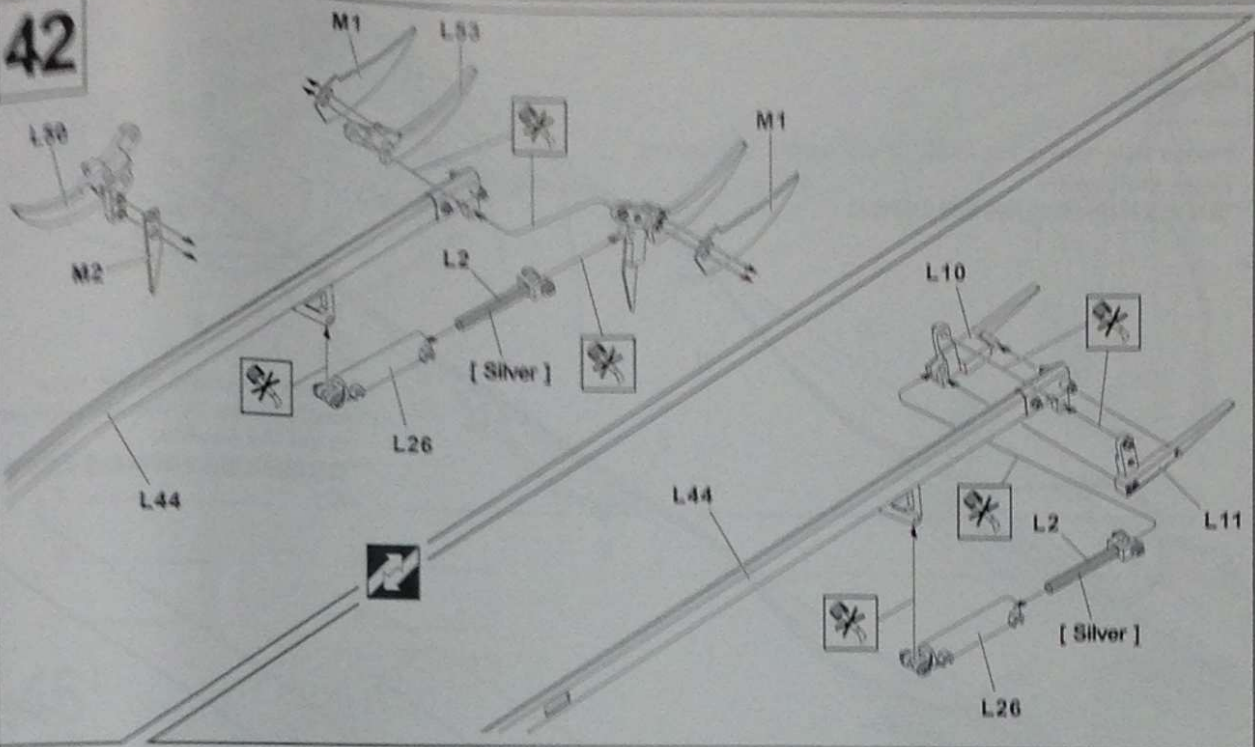

# 43

\*\*Please determining the angle of the robotic arm before install the pipeline.  
\*\*請在決定好機械臂的角度後再安裝管線。

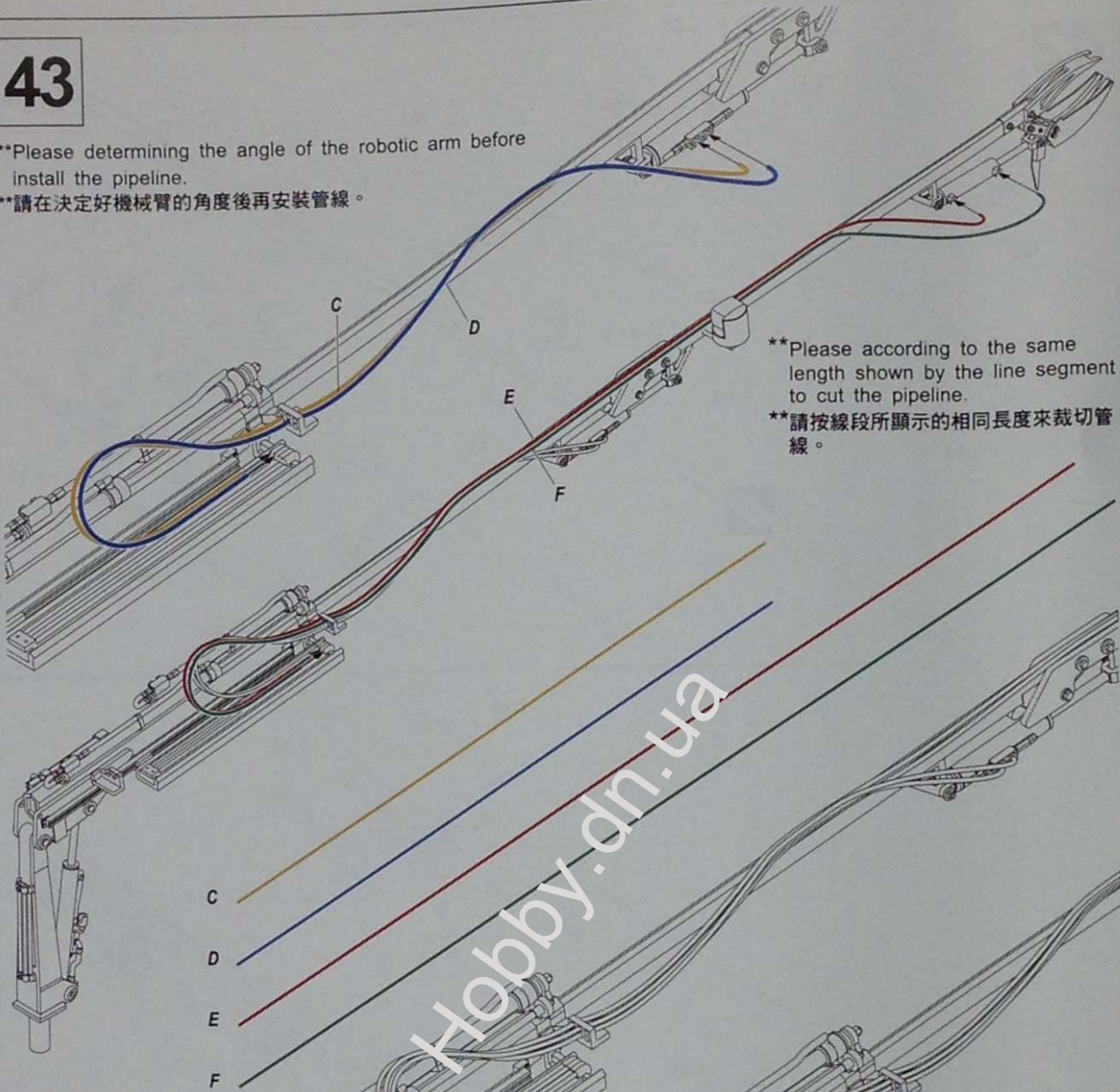

# 44

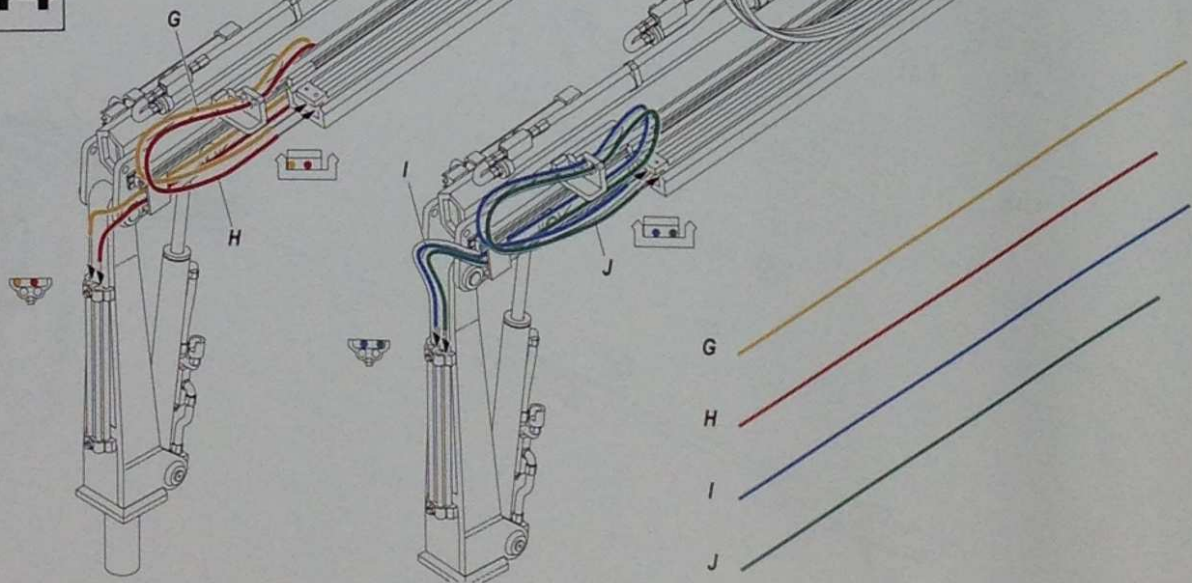

45

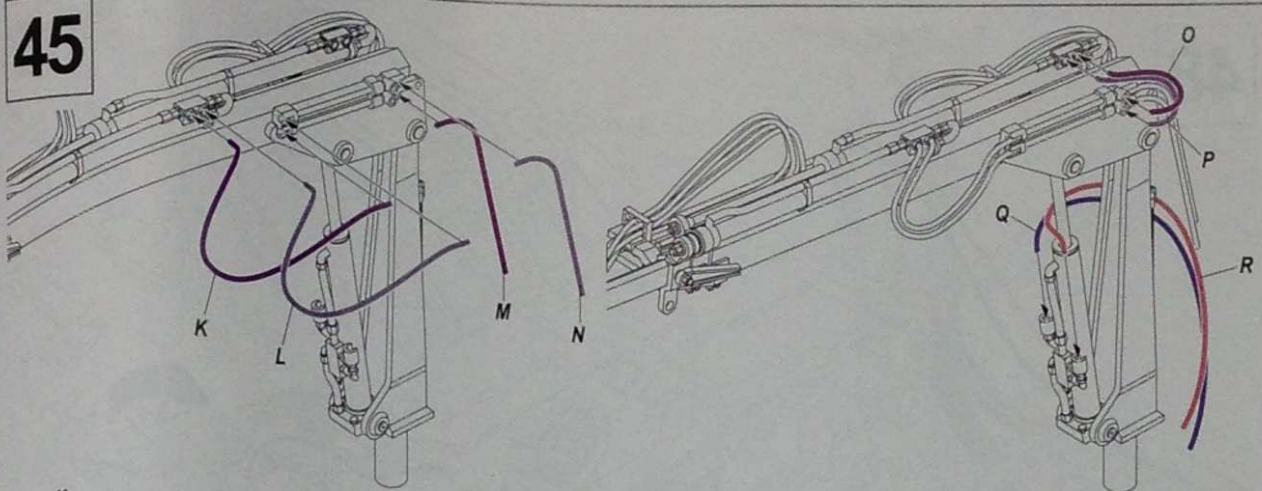

- K \_\_\_\_\_
- L \_\_\_\_\_
- M \_\_\_\_\_
- N \_\_\_\_\_
- O \_\_\_\_\_
- P \_\_\_\_\_
- Q \_\_\_\_\_
- R \_\_\_\_\_

46

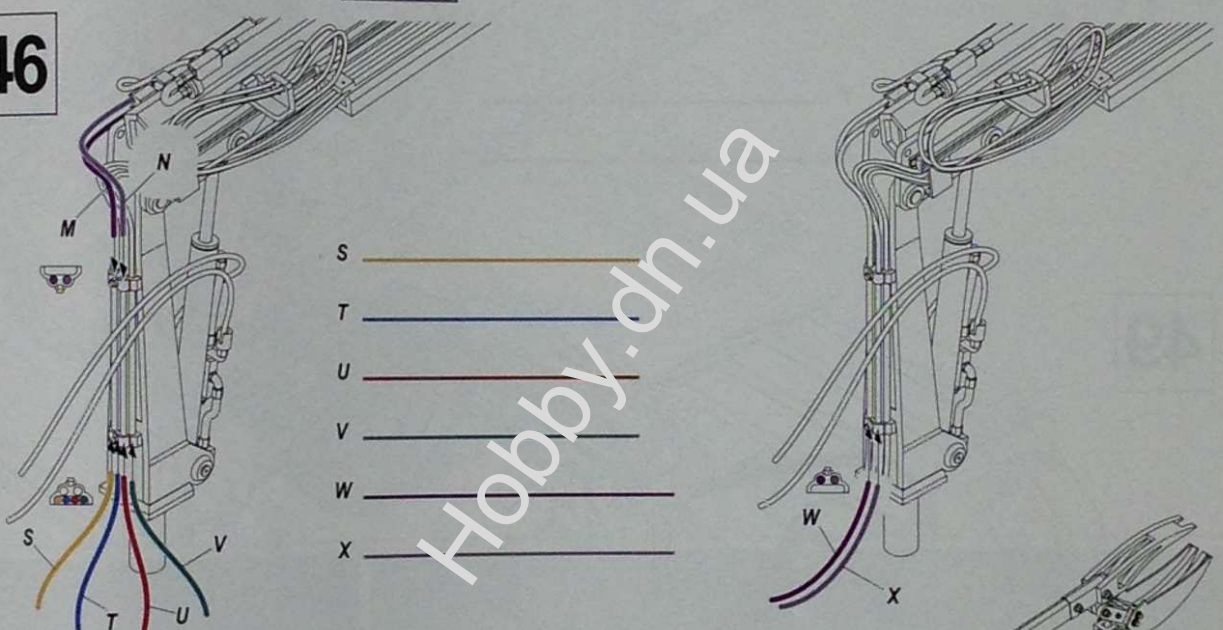

- S \_\_\_\_\_
- T \_\_\_\_\_
- U \_\_\_\_\_
- V \_\_\_\_\_
- W \_\_\_\_\_
- X \_\_\_\_\_

47

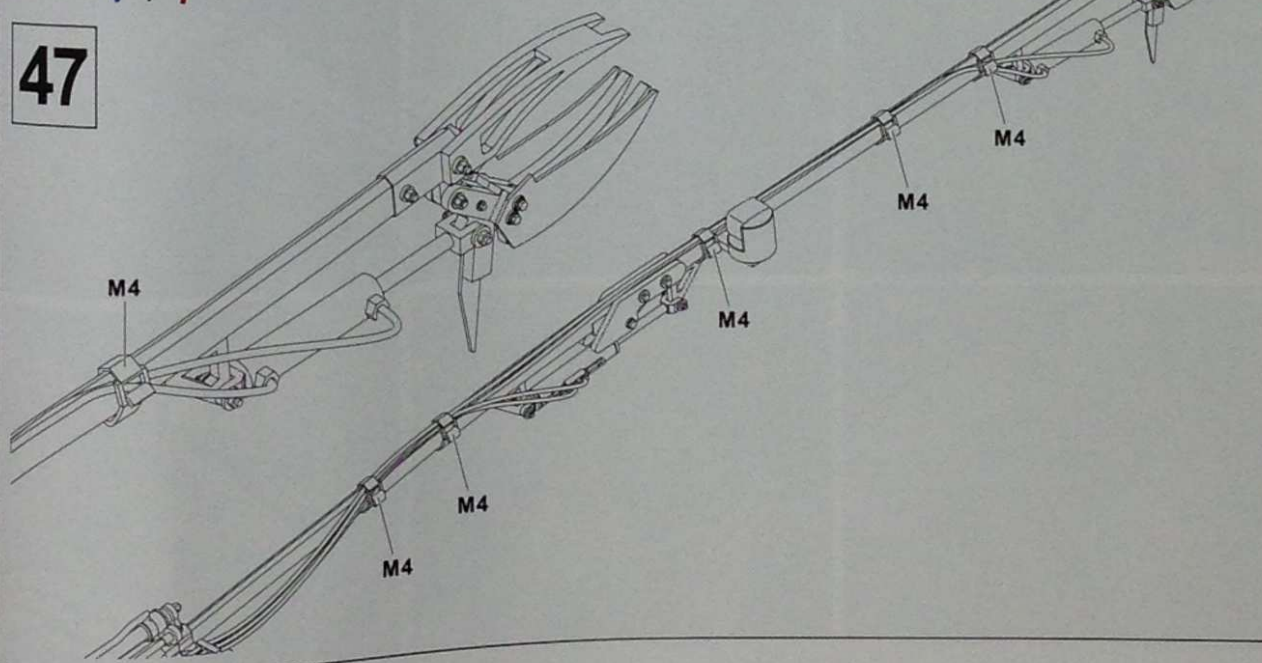

48

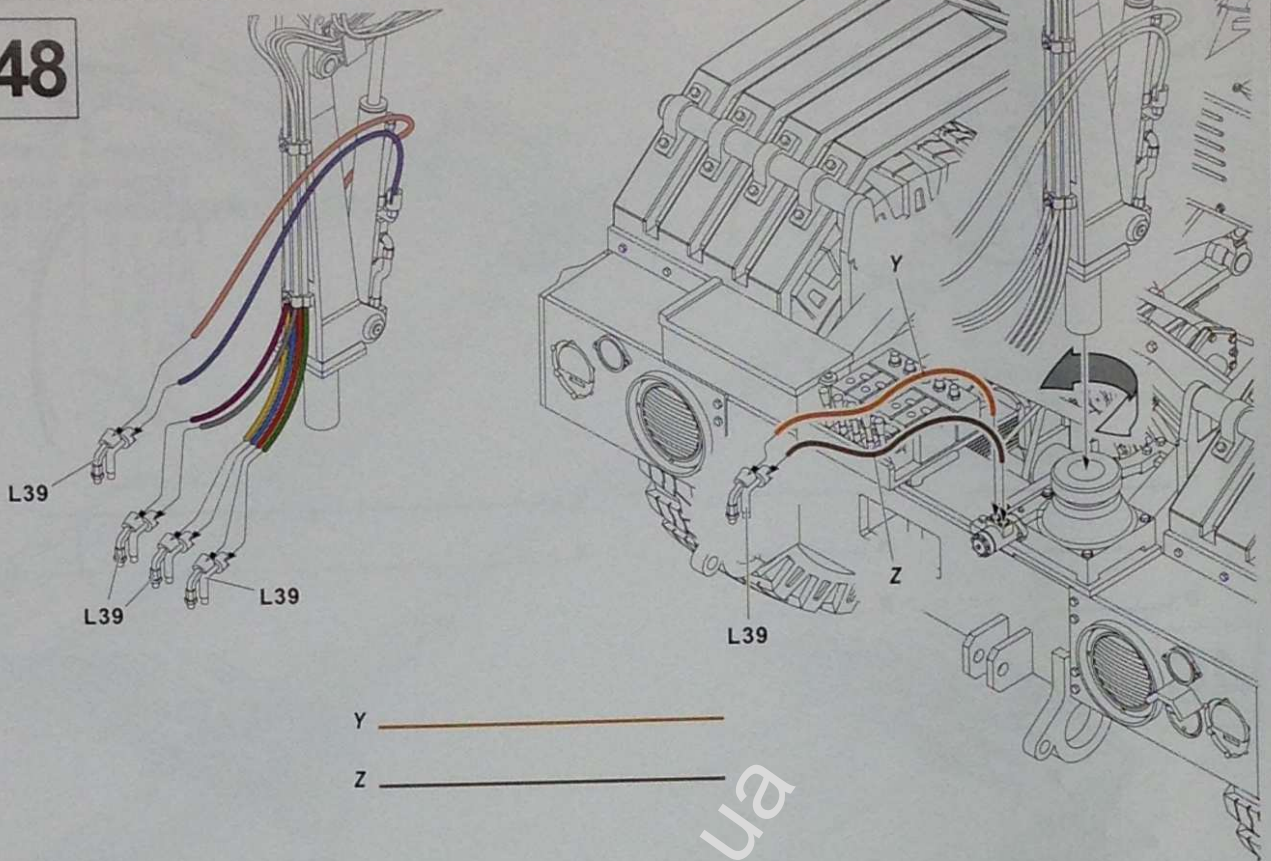

49

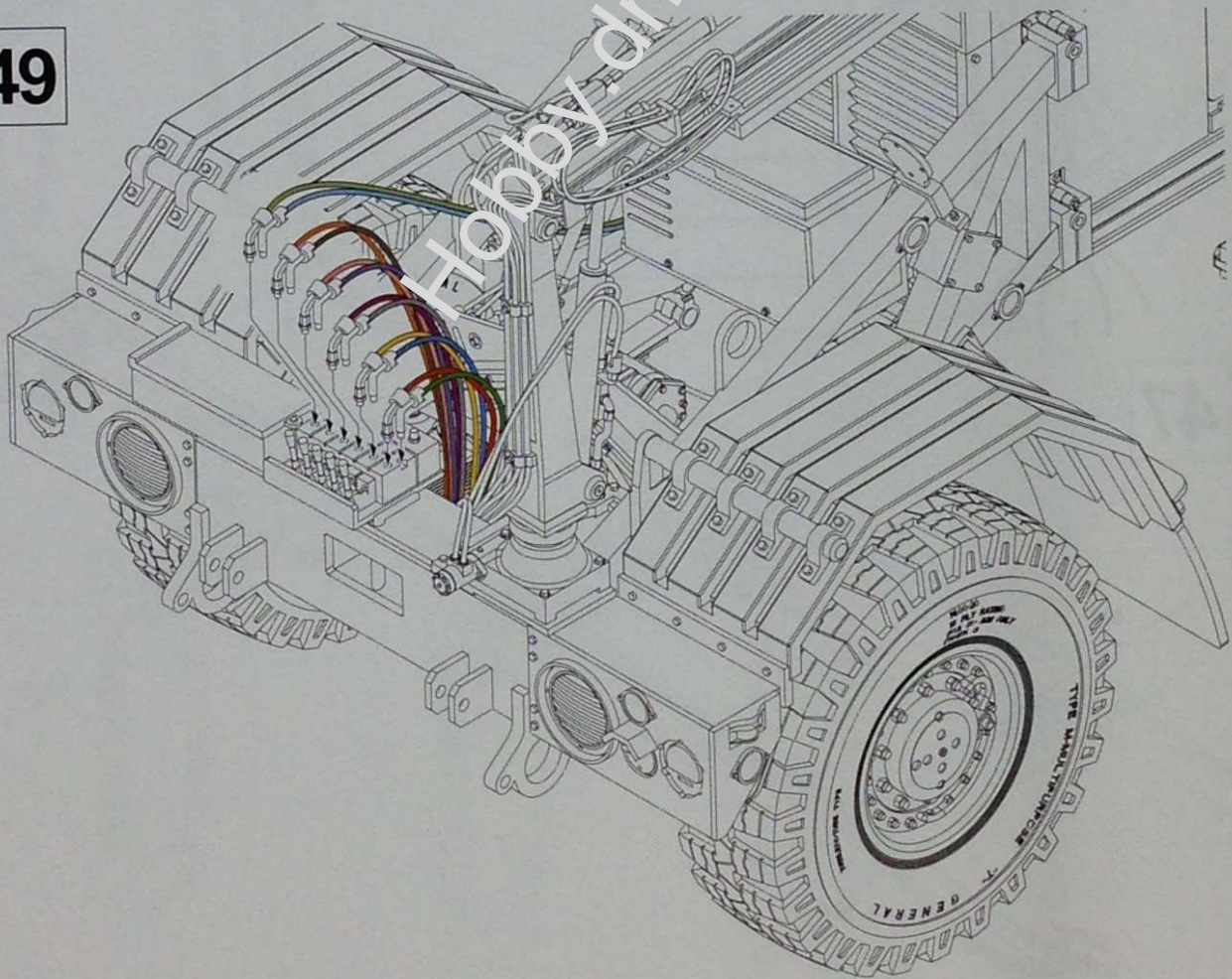

50

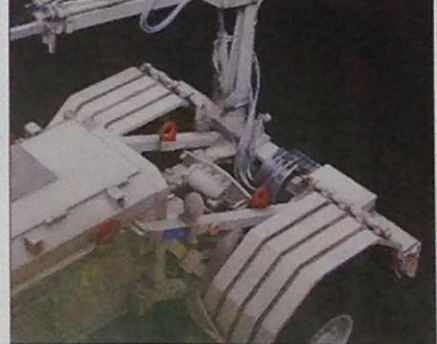
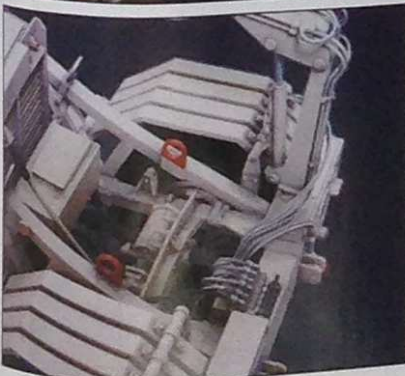
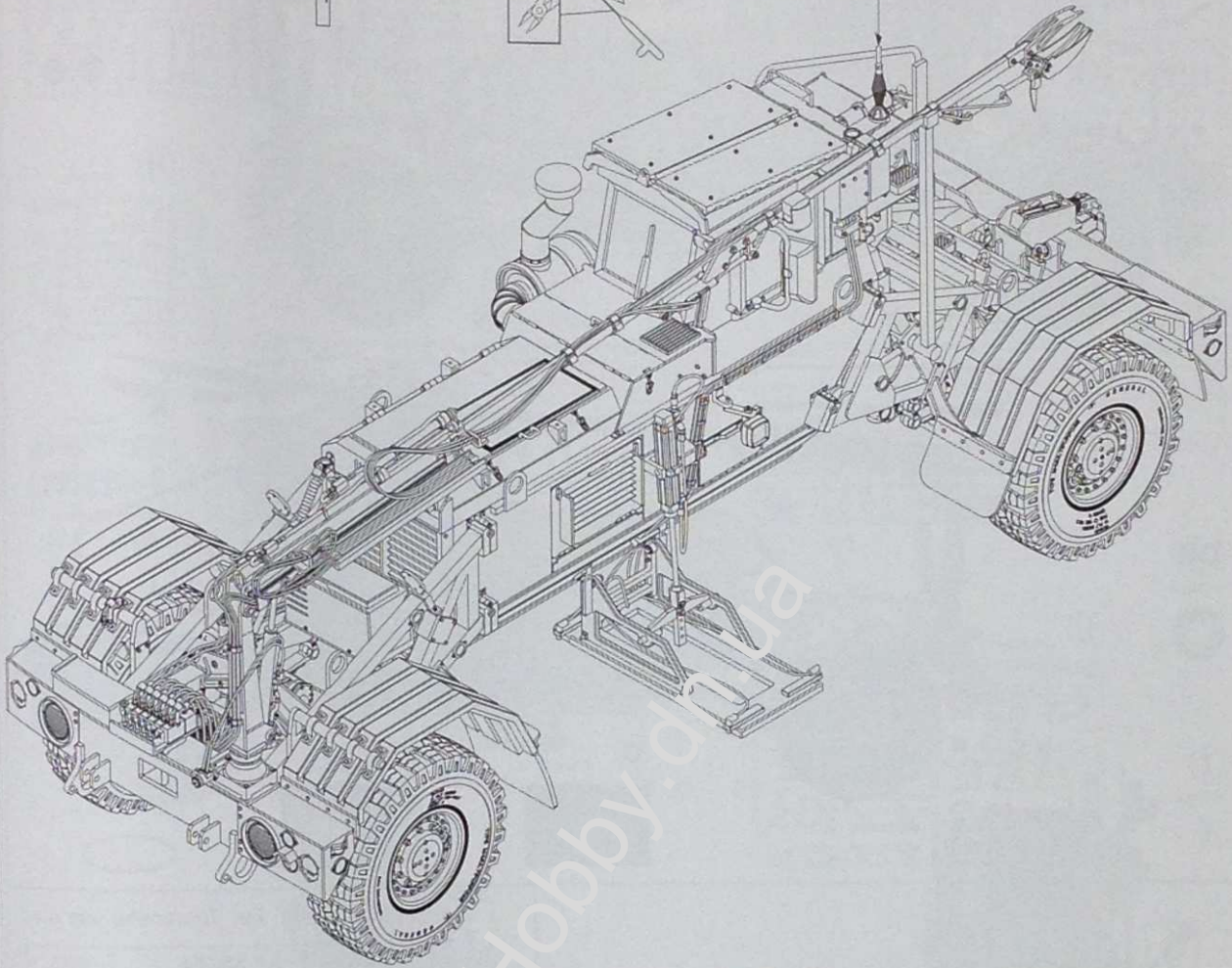
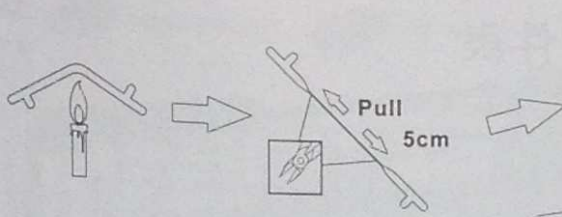

# PARTS LIST 零件表

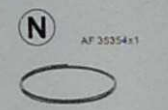
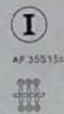
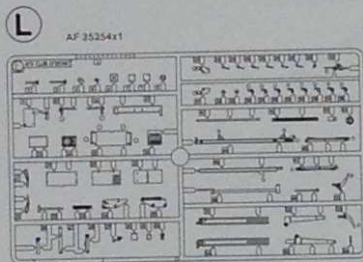
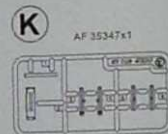
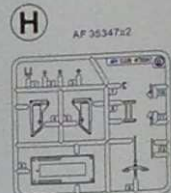
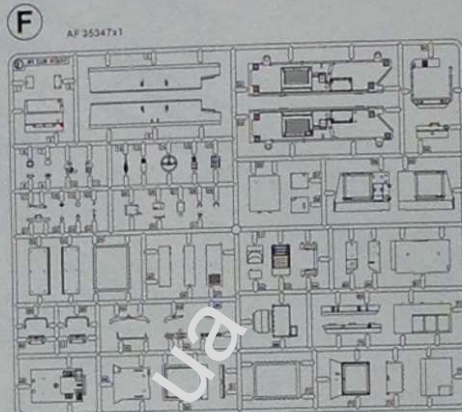
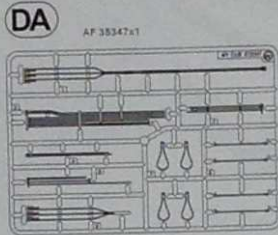
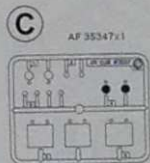
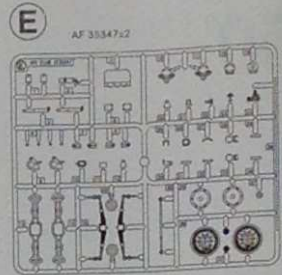
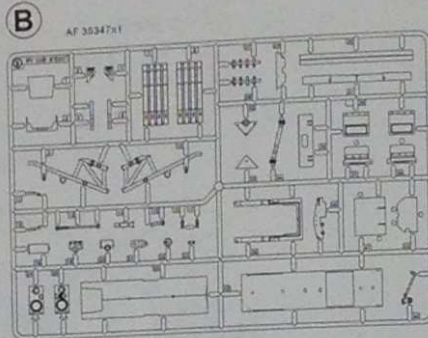
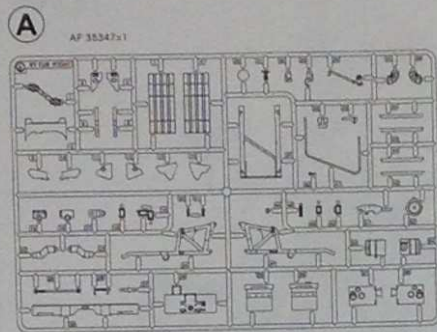

## Instructions:

If for some reason, you are not fully satisfied or have questions concerning our product, Please use the form provide, and send it to our nearest representative or mail it directly to our office.

We will deal with that A.S.A.P.



## AF 35354 Parts Replacement Form

- |                                      |                                     |
|--------------------------------------|-------------------------------------|
| <input type="checkbox"/> AF 35347-A  | <input type="checkbox"/> AF 35347-H |
| <input type="checkbox"/> AF 35347-B  | <input type="checkbox"/> AF 35S15-I |
| <input type="checkbox"/> AF 35347-C  | <input type="checkbox"/> AF 35354-J |
| <input type="checkbox"/> AF 35347-DA | <input type="checkbox"/> AF 35347-K |
| <input type="checkbox"/> AF 35347-DB | <input type="checkbox"/> AF 35354-L |
| <input type="checkbox"/> AF 35347-E  | <input type="checkbox"/> AF 35354-M |
| <input type="checkbox"/> AF 35347-F  | <input type="checkbox"/> AF 35354-N |
| <input type="checkbox"/> AF 35347-G  |                                     |

Reason for replacement:  Missing  
 Broken

Signature \_\_\_\_\_

限臺灣地區使用 For Taiwanese use only!



## AF 35354 零件補充申請表

申請人  
姓名 地址 電話

- |                                      |          |
|--------------------------------------|----------|
| <input type="checkbox"/> AF 35347-A  | NT\$ 350 |
| <input type="checkbox"/> AF 35347-B  | NT\$ 350 |
| <input type="checkbox"/> AF 35347-C  | NT\$ 120 |
| <input type="checkbox"/> AF 35347-DA | NT\$ 280 |
| <input type="checkbox"/> AF 35347-DB | NT\$ 120 |
| <input type="checkbox"/> AF 35347-E  | NT\$ 180 |
| <input type="checkbox"/> AF 35347-F  | NT\$ 380 |
| <input type="checkbox"/> AF 35347-G  | NT\$ 160 |
| <input type="checkbox"/> AF 35347-H  | NT\$ 240 |
| <input type="checkbox"/> AF 35S15-I  | NT\$ 60  |
| <input type="checkbox"/> AF 35354-J  | NT\$ 160 |
| <input type="checkbox"/> AF 35347-K  | NT\$ 120 |
| <input type="checkbox"/> AF 35354-L  | NT\$ 280 |
| <input type="checkbox"/> AF 35354-M  | NT\$ 250 |
| <input type="checkbox"/> AF 35354-N  | NT\$ 60  |

+郵寄費 \_\_\_\_\_ NT\$ 80  
(請填)總計NT\$ \_\_\_\_\_

零件補充原因(請於打√)  
原包裝即遺失或毀損,  
製作途中遺失或毀損,  
其他原因 \_\_\_\_\_

總代理 戰鷹企業有限公司收本公司將儘速為您處理。  
請將本表與該部品相同金額之郵政匯票一同寄至

A



Body Color:



Yellow FS33531



Flat red

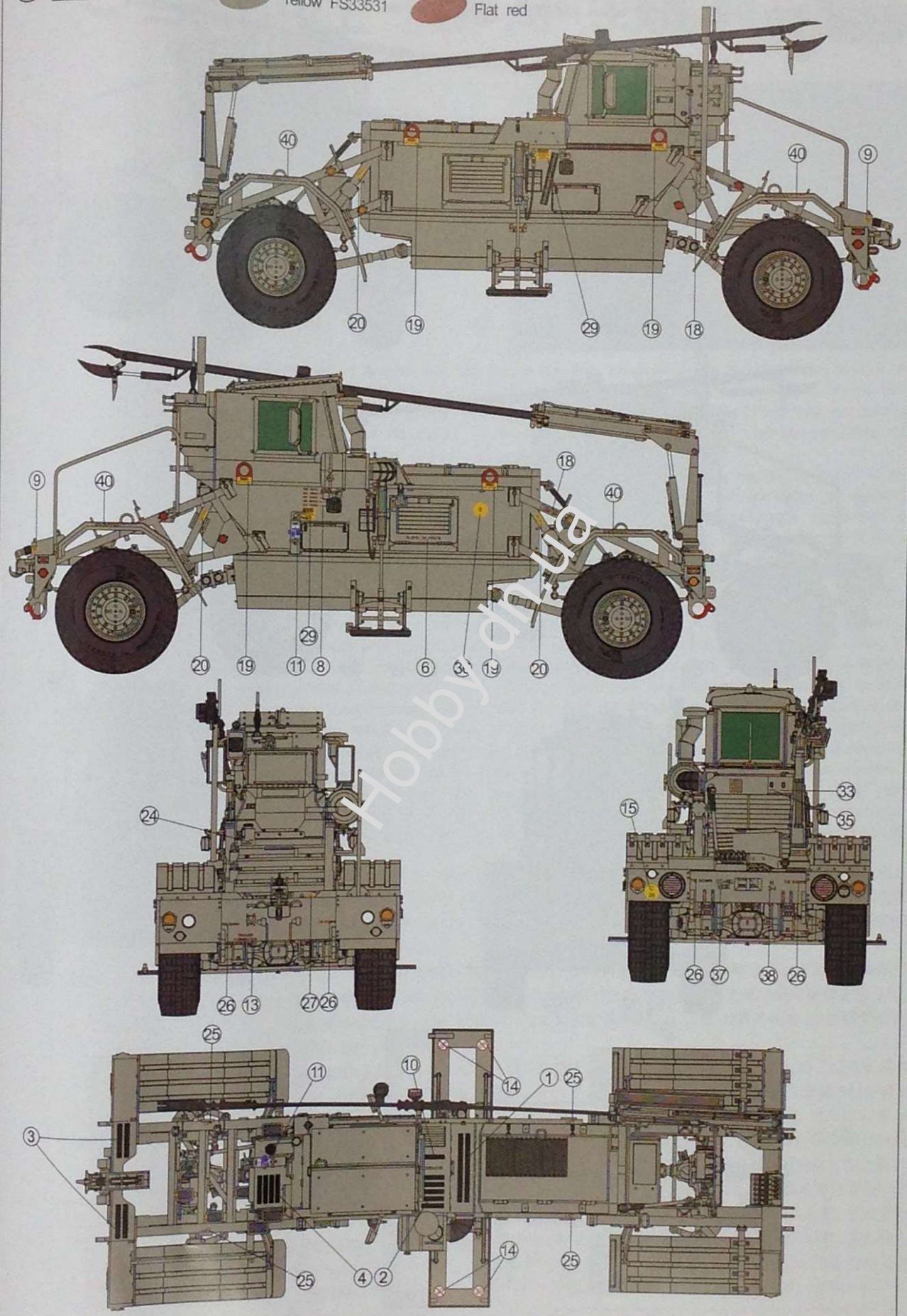

B



Body Color:



Yellow FS33531



Flat red

