



1:700 Gift Set R.M.S. Titanic

A50164A SCALE MODEL CONSTRUCTION KIT

EN The RMS Titanic has its place in maritime history as not just the largest and most luxurious passenger ship afloat upon its launch in 1912, but also as the most infamous, due to its now legendary maiden voyage.

Built at the Harland and Wolff shipyard in Belfast, the Titanic was commissioned by the White Star Line to be a direct competitor to its newest and most luxurious Atlantic liners. Designed to be unsinkable, with a number of water-tight compartments along the length of her hull, construction of the Titanic was not without its' difficulties. Work had to be delayed due to repairs being undertaken on her sister ship, the Olympic, necessitating parts from the Titanic being transferred to the other liner.

The Titanic was designed to herald a new era in cross-Atlantic travel. With previously unheard of luxuries available for its first class passengers, they had access to various baths, a swimming pool, gymnasium, squash court and even a barbers shop was aboard the vessel. For its maiden voyage in April 1912, the cost of a first class ticket was £875 one way, or £64,000 in today's money.

The Titanic departed Southampton on the 10th of April 1912, captained by the experienced Edward J. Smith. She stopped first at Cherbourg, France, then Cobh, Ireland, to pick up further supplies and passengers before then making her way out into the Atlantic on her maiden voyage to New York.

The first part of the journey was uneventful, but this was to change at 11:40pm on the night of the 14th of April. Two lookouts spotted a large iceberg directly ahead of the ship and despite frantic orders to change course, the liner was not able to react in time and just 30 seconds later the iceberg tore a gash in the starboard hull of the ship. This in turn popped rivets along the length of the hull hastening the filling of the water-tight compartments. Water rapidly

filled the hull and the vessel was doomed.

It became rapidly apparent to the officers on board that there was no chance of saving the ship and at 12:45am, the first of the lifeboats began to be lowered into the water. However, the first boats left barely filled, as the passengers on board, believing the ship to be unsinkable, took some persuasion to abandon the large liner and head for the small wooden lifeboats. By 2:00am, the fact the Titanic was sinking became apparent to all. The stern had risen clean out the water exposing the propellers and shortly afterwards, the water reached the boat deck. The remaining passengers clung desperately onto the top of the stern to prevent themselves falling into the icy waters, but at 2:20am, the bow and stern separated, with the bow sinking first and the stern following shortly afterwards.

Of the 2224 people aboard the ship, 711 survived and due to the orders given on deck that they should be first to leave, the vast majority of these were first and second class women and children. Just 75 of the 462 third class male passengers survived the sinking. With many families losing their sole breadwinner, there was a large charity drive for the survivors in the aftermath of the sinking.

Much criticism of the White Star Line followed the sinking, as it transpired that there were not enough lifeboats for all of the passengers, but the Titanic had complied with the laws of the period that dictated the number of boats based on tonnage, not on passenger numbers.

The wreck of the Titanic was found by Dr. Robert Ballard in 1985 and now even 100 years after its maiden voyage and tragic loss, the legend of the Titanic continues to hold the imagination of the world.

Length: 261.9m Height: 53.3m Beam: 28m Decks: 9 Speed: 21 Knots Capacity: 3547 Passengers and Crew.

WARNING

Not suitable for children under 8 years. For use under adult supervision. Read the instructions before use, follow them and keep them for reference.

WAARSCHUWING

Niet geschikt voor kinderen jonger dan 8 jaar. Gebruiken onder toezicht van volwassenen. Lees eerst de gebruiksaanwijzing en volg deze op. Bewaar deze om later te kunnen raadplegen.

ATTENTION

Ne convient pas aux enfants de moins de 8 ans. À utiliser sous la surveillance d'un Adulte. Lire les instructions avant utilisation, s'y conformer et les garder comme référence.

OSTRZEŻENIE

Nie nadaje się dla dzieci w wieku poniżej 8 lat. Do użytkowania pod nadzorem osoby dorosłej. Przeczytaj instrukcję przed użyciem. Postępuj zgodnie z ich zaleceniami i zachowaj ją do dalszego użycia.

ΠΡΟΕΙΔΟΠΟΙΗΣΗ

Δεν είναι κατάλληλο για παιδιά κάτω των οκτώ ετών. Να χρησιμοποιείται μόνο υπό την επίβλεψη ενήλικου. Διαβάστε αυτές τις οδηγίες πριν από τη χρήση, ακολουθήστε τις και κρατήστε τις για μελλοντική χρήση.

ACHTUNG

Nicht geeignet für Kinder unter ... Jahren 8. Benutzung unter Aufsicht von Erwachsenen. Lies die Anweisungen vor Gebrauch, befolge sie und halte sie nachschlagbereit.

ADVERSEL

Ikke egnet for barn under 8 år. Skal brukes under tilsyn av en voksen. Les bruksanvisningene før bruk, følg dem og ta vare på dem.

VAROITUS

Ei alle 8 -vuotiaalle lapsille. Lelua saa käyttää vain aikuisen valvonnassa. Lue käyttöohjeet ennen käyttöä ja noudata niitä. Säilytä ohjeet vastaisuuden varalle.

ADVERTENCIA

No conviene para niños menores de 8 años. Utilícese bajo la vigilancia de un adulto. Leer las instrucciones antes de la utilización, seguir las y conservarlas como referencia.

AVVERTENZA

Non adatto a bambini di età inferiore a 8 anni. Da usare sotto la sorveglianza di un adulto. Leggere le istruzioni prima dell'uso, attenersi ad esse e conservarle per riferimento futuro.

ADVARSEL

Ikke egnet for børn under 8 år. Skal anvendes under opsyn af en voksen. Læs brugsanvisningen før brug, følg den og gem den til senere brug.

VARNING

Inte lämplig för barn under 8 år. Ska användas under tillsyn av vuxen. Läs anvisningarna före användningen, följ dem och spara dem för framtida bruk.

ATENÇÃO

Contra-indicado para crianças com menos de 8 anos. A utilizar sob a vigilância de adultos. Ler as instruções antes de utilizar e conservá-las como informação.

UPOZORNĚNÍ

Nevhodné pro děti do 8 let. Používat pouze pod dohledem dospělých osob. Před použitím si přečtěte návod, dodržujte jej a uschovejte jej pro pozdější potřebu.

FOR BEST RESULTS:

Surfaces to be painted should be clean – before parts are removed from the sprue, wash in warm, soapy water, rinse and dry thoroughly. Stir paints thoroughly before use.

PLEASE NOTE:

Additional paints may sometimes be required to complete models to a higher specification. Some parts in the kit may not be required to build the model specified.

**HORNBY
HOBBIES**



Parts Locating Diagram

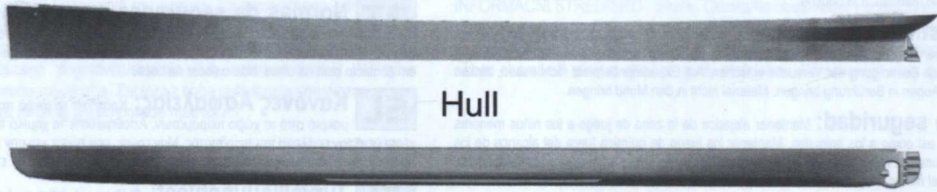
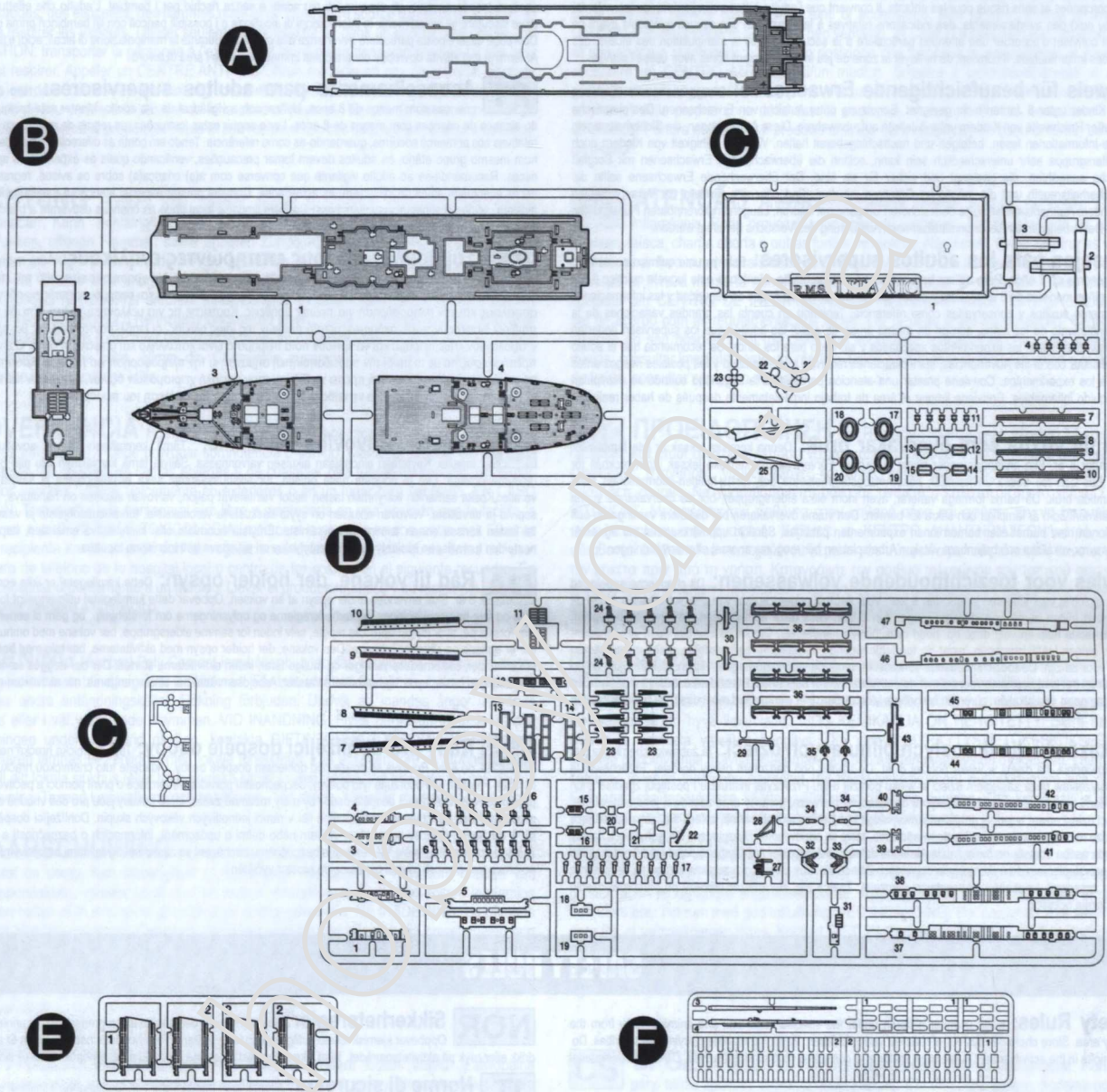

Hull

1

B1 (top view)

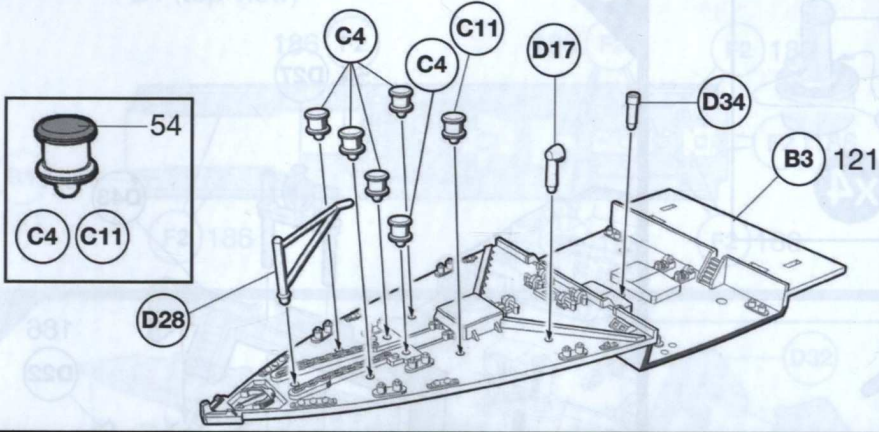

3

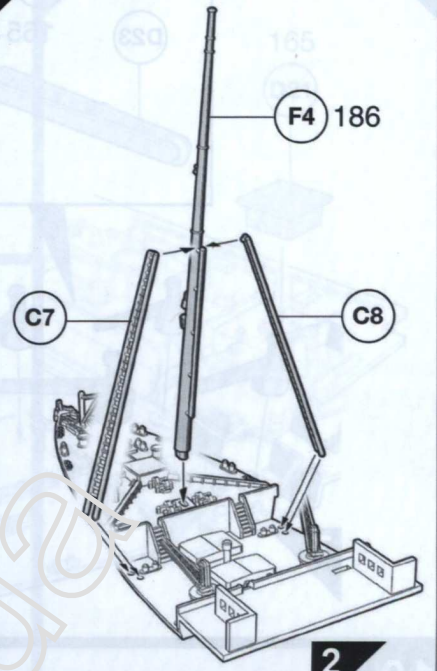

2

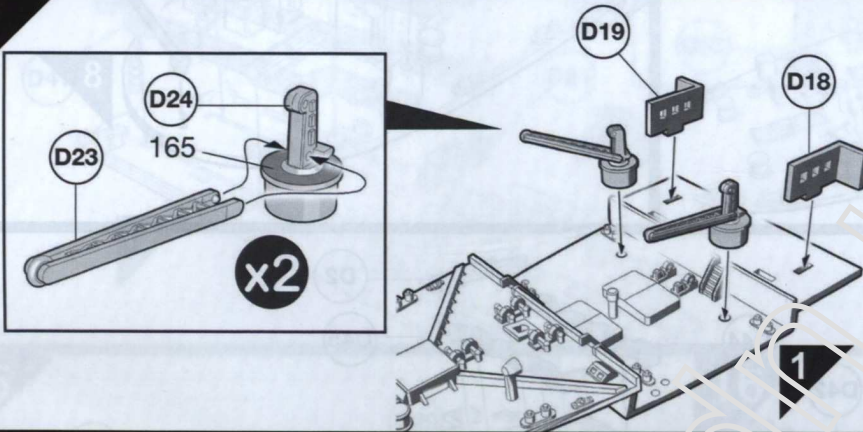

4

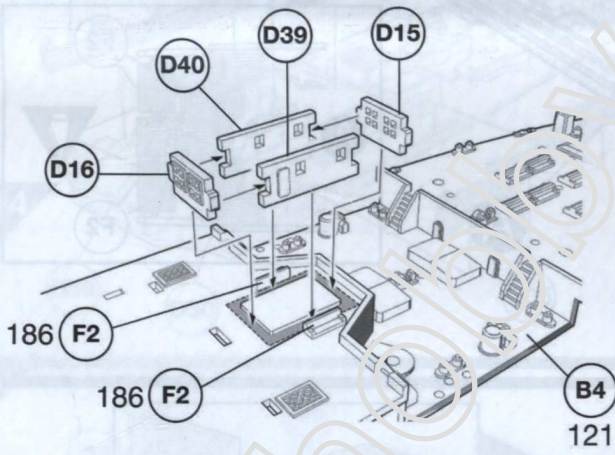

5

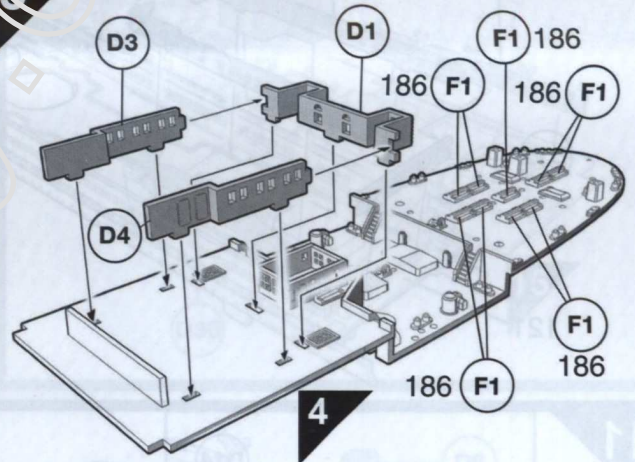

6

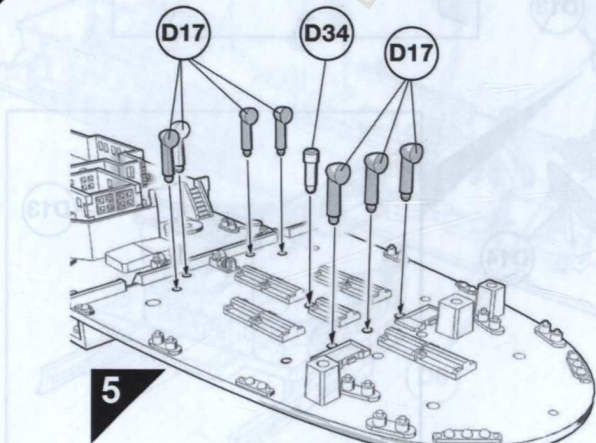

7

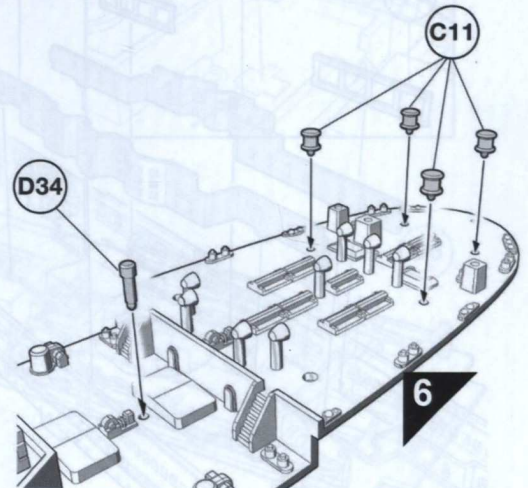

8

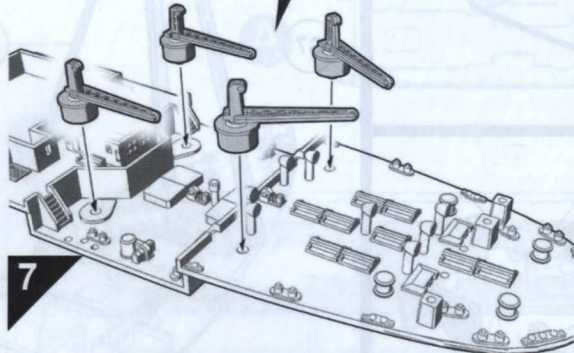
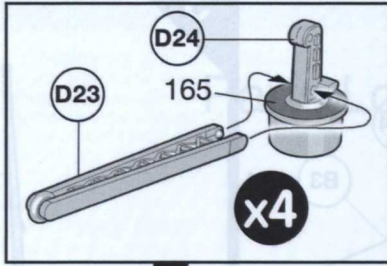

9

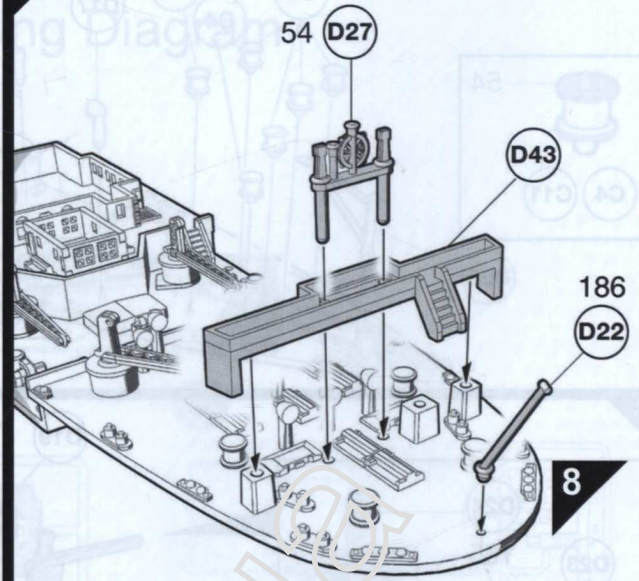

10

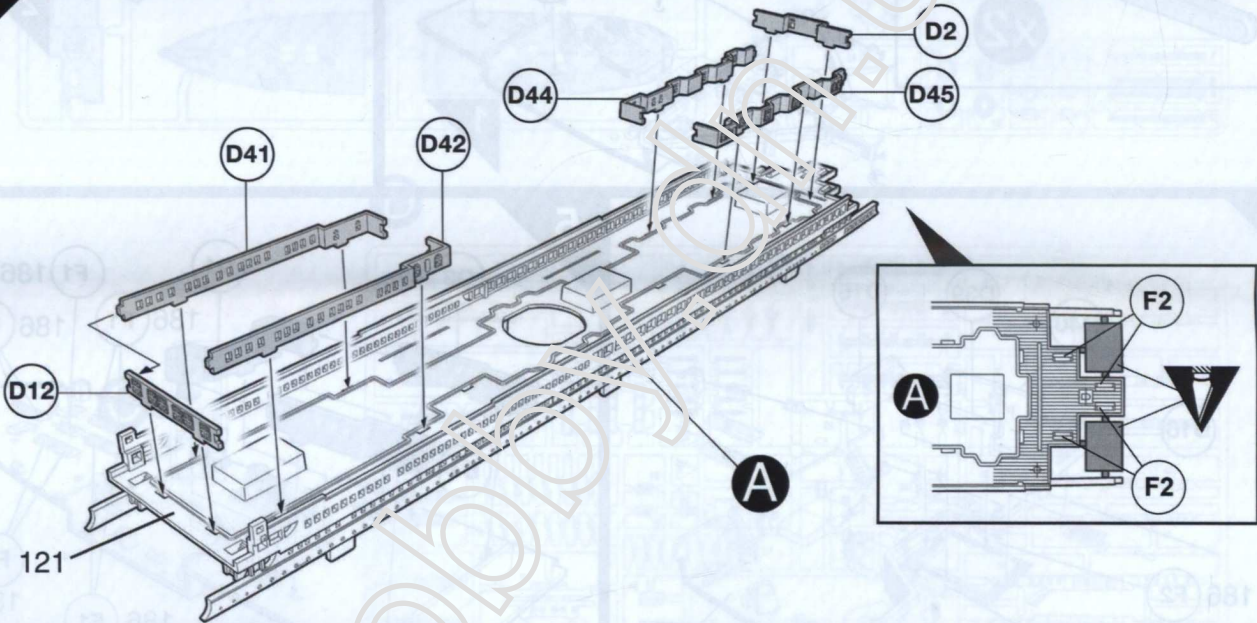

11

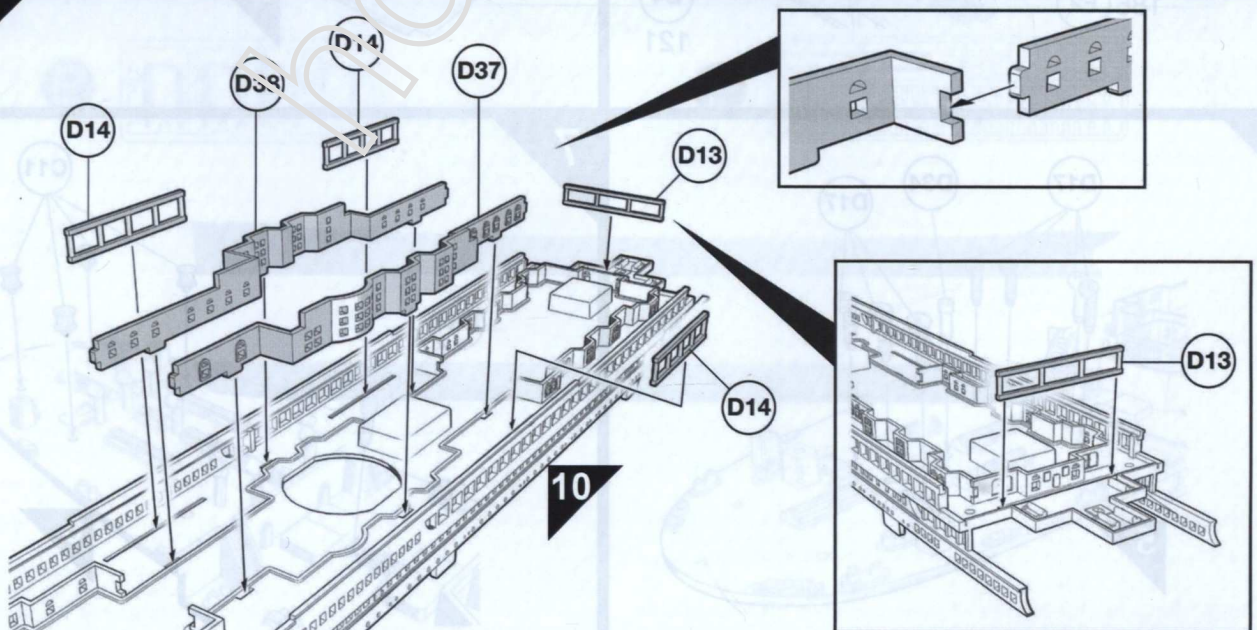

12

B1 (top view)

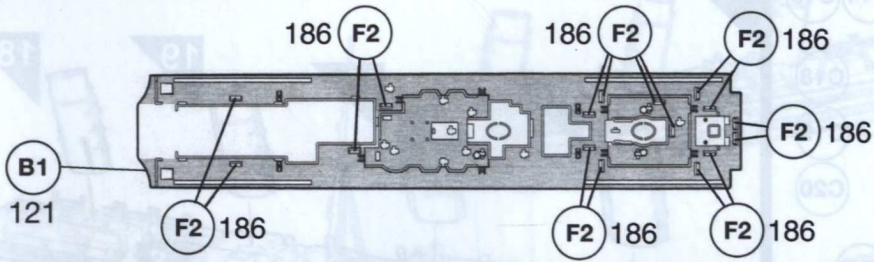

14

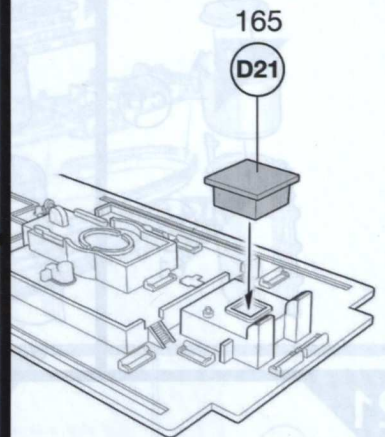

13

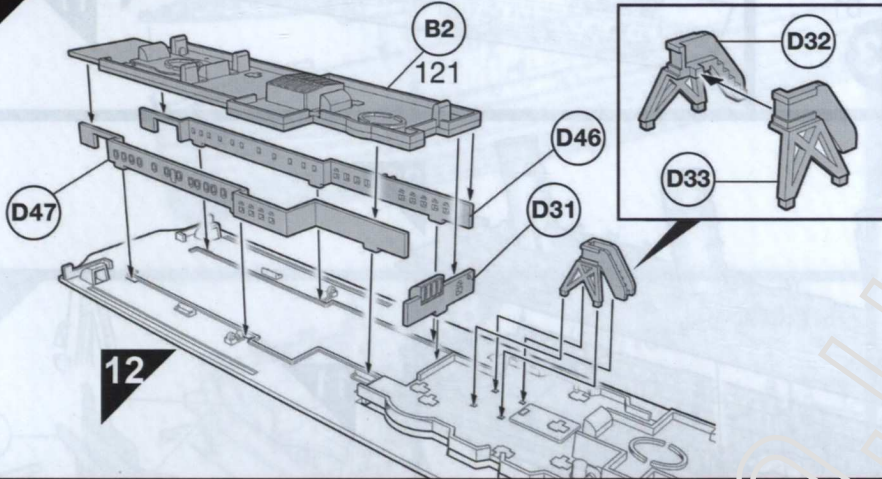

13

15

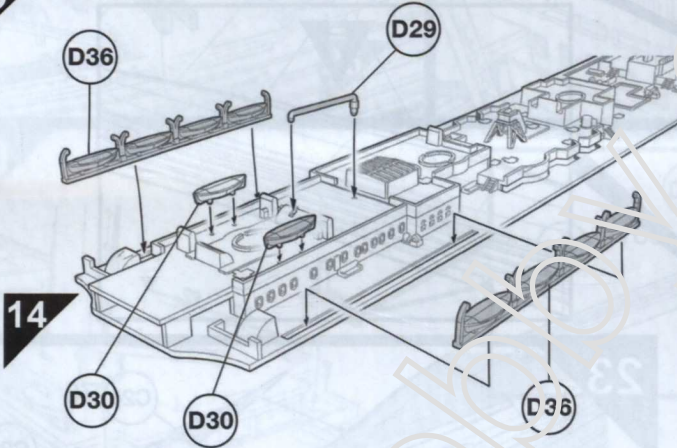

14

16

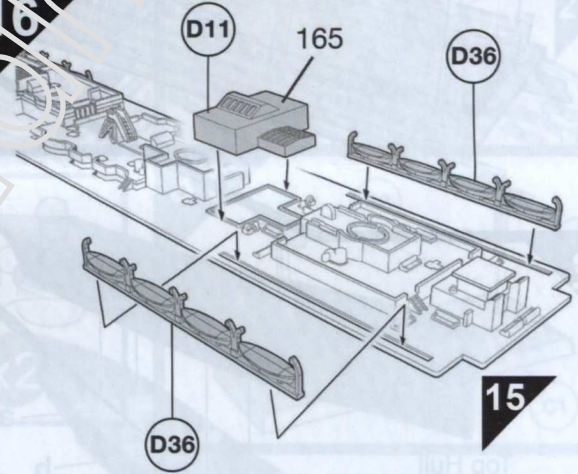

15

17

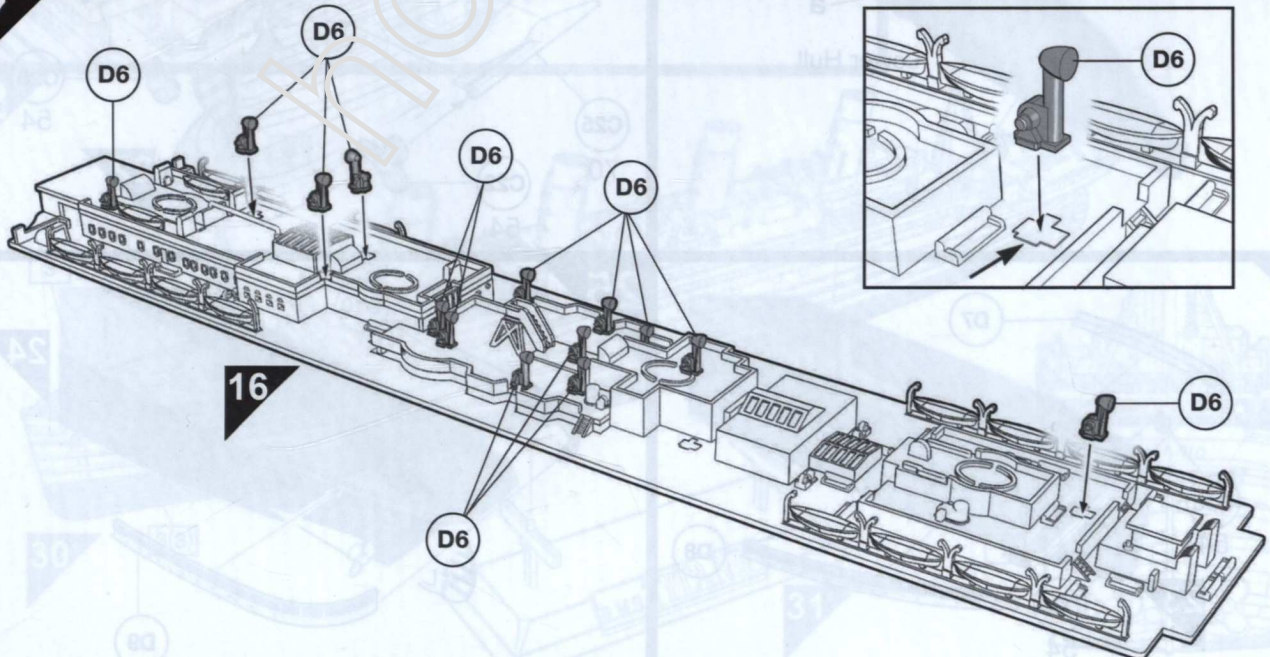

16

18



19

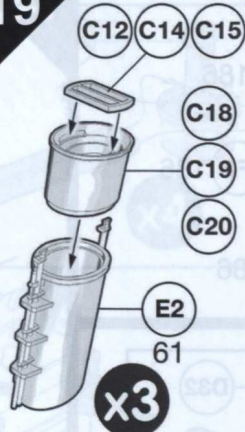

20

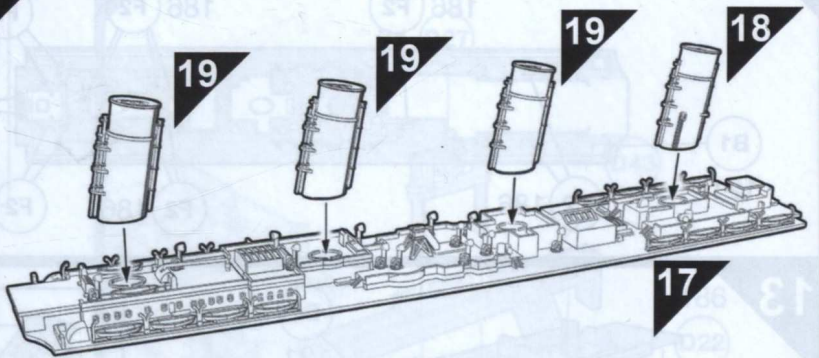

21

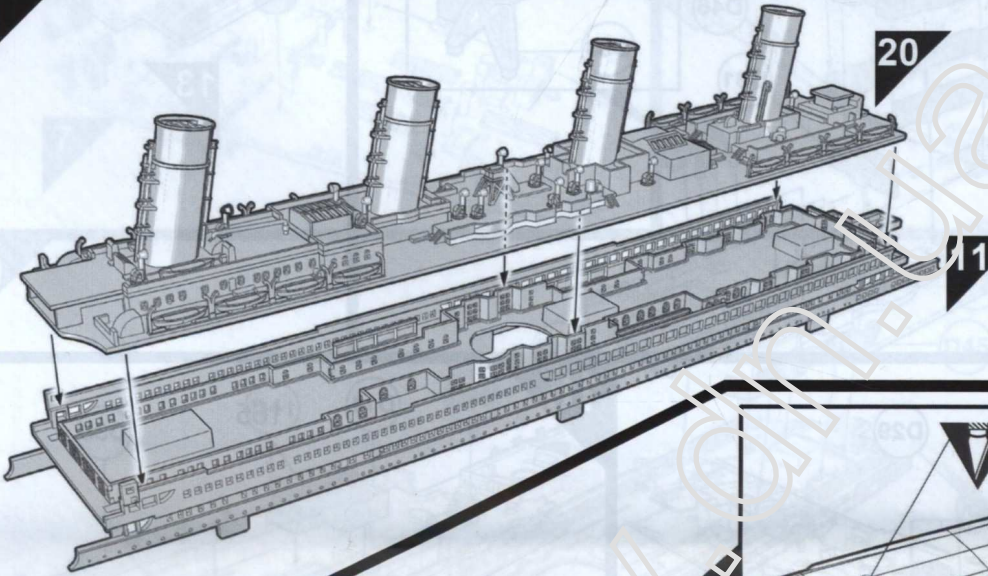

22

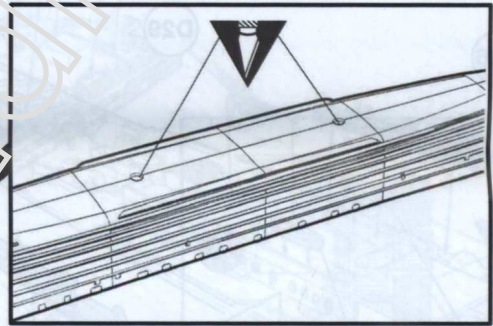
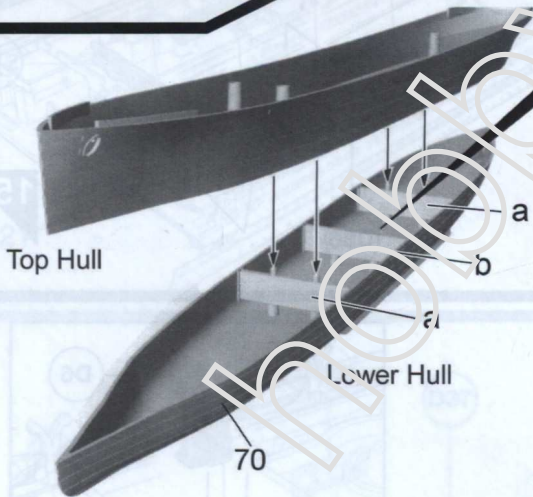

23

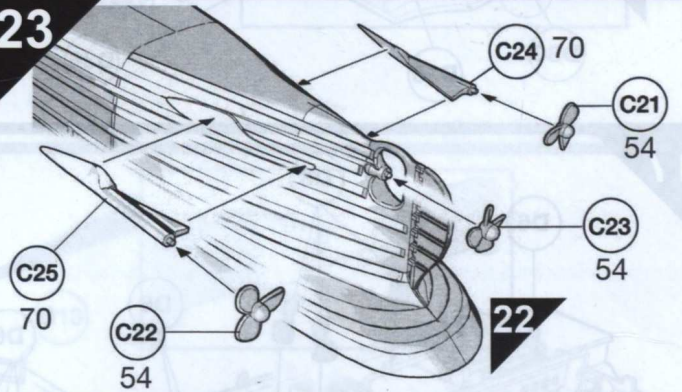

24

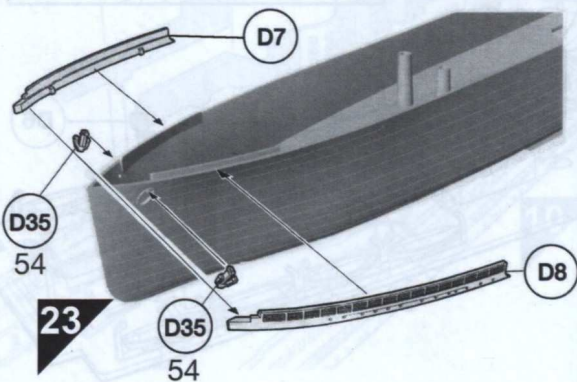

25

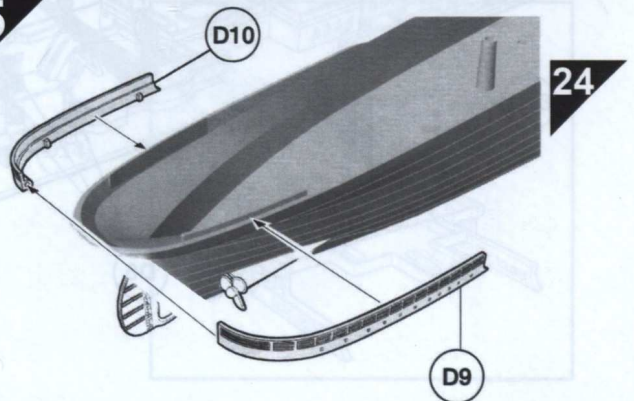

26

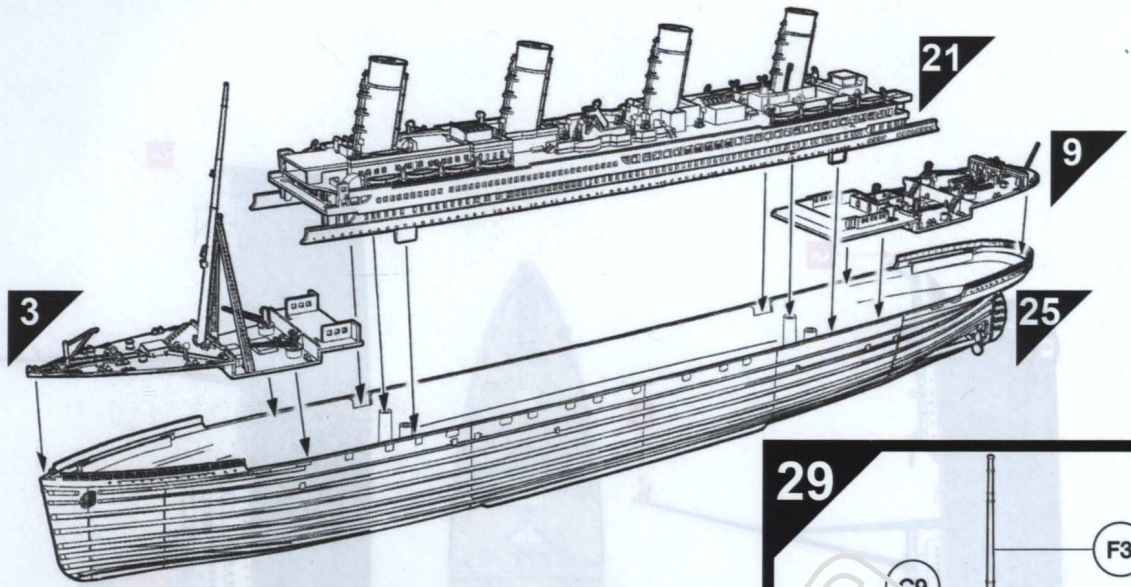

27

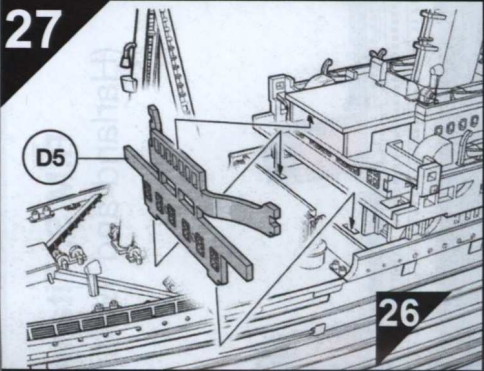

28

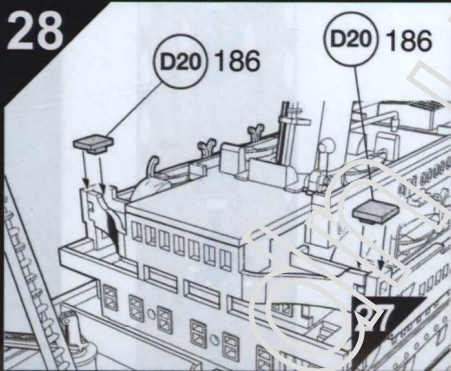

29

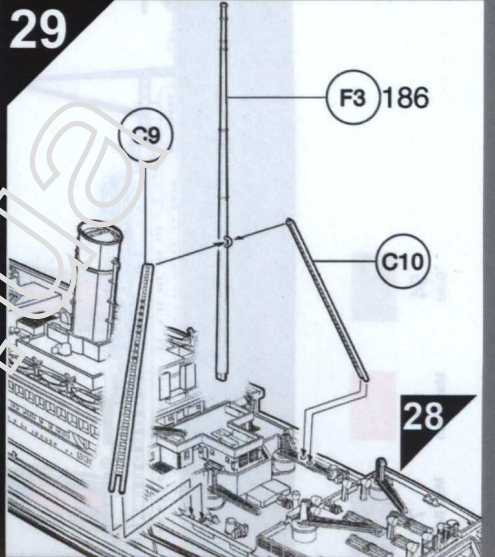

30

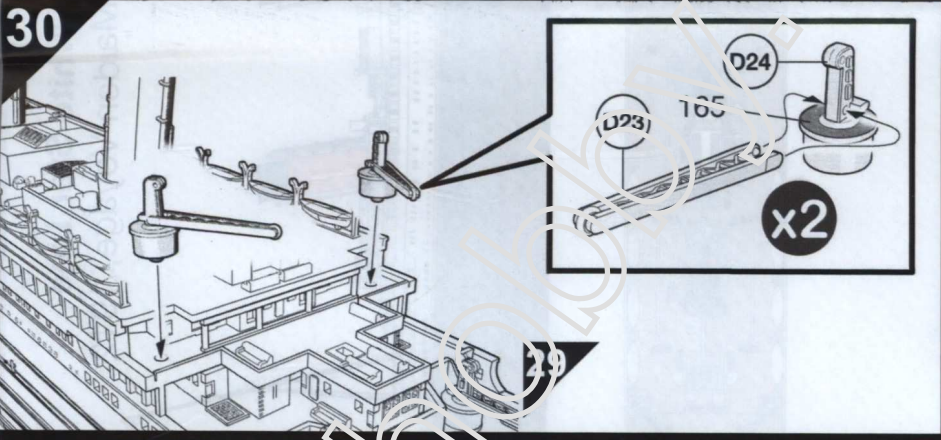

31

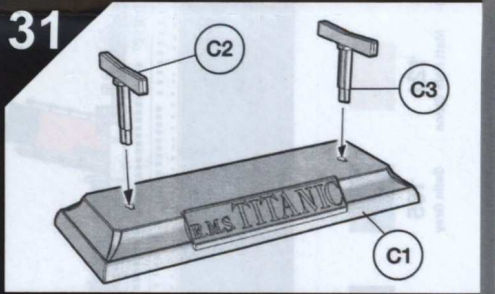



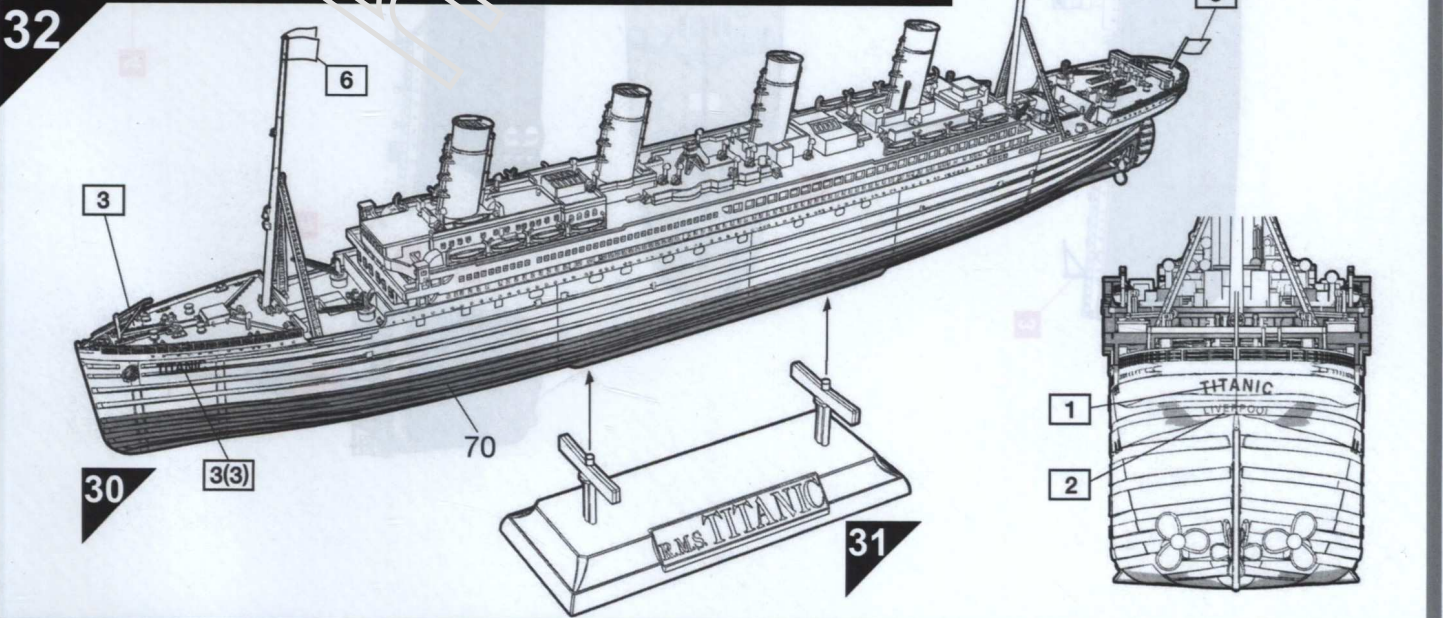

32

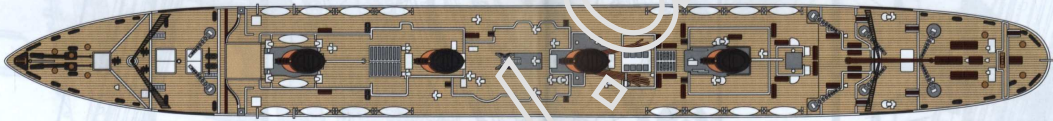

R.M.S. Titanic, White Star Line
(Harland and Wolff) Maiden Voyage, 1912



					
54 Gold	61 Matt Flesh	70 Matt Brick Red	121 Matt Pale Stone	165 Satin Grey	186 Brown