



Messerschmitt BF.109 A-1

The Messerschmitt Bf 109's versatility and time in service with both the German Luftwaffe and other foreign air forces, numerous variants were produced over the eight years of service with the Luftwaffe and even more were produced by its foreign service.

Willy Messerschmitt & Walter Rethel designed the Bf 109 in response to an official government request for a monoplane fighter. They sensibly designed their new fighter around the smallest airframe (length 8,5 m & wingspan 9,7 m), that could accommodate the most powerful motor available at the time, the liquid-cooled 660 HP Junkers Jumo 210A. This design philosophy was to serve the new fighter well during its long combat career.

The Bf 109 prototype first flew 02 05 1935. It was the first fighter to incorporate all of the features that would make the final generation of piston-engine fighters so successful during the WW II. It was an all metal, stressed skin monocoque, single seat, monoplane fighter with an enclosed cockpit and retractable landing gear.

The Me 109's track record is unparalleled. The Bf 109A entered service during the Spanish Civil war with the Condor Legion, where in 1936 it demonstrated its superiority against the I-16 monoplane fighter supplied to the Republican AF by the USSR.

The Bf 109 A was the first serial version of the Bf 109. A total of 22 Bf-109 A were built

References:

- Messerschmitt Bf 109 A-D models, KAGERO, M.Lukasik
- Messerschmitt Bf 109, WARPAIN Special N 2,
- Bf 109 part 1, SAM Datafile N 09,
- Me 109 A bis Me 109 E, Aviatic Verlag, 1997,
- Messerschmitt Me-109, W.Ridinger & W Schick,
- Cockpits DSeutscher Flugzeuge 1911-70, P.W. Cohauz,
- Luftwaffe Camouflage and Markings 1933-1945 vol.1, K.A. Merrick,
- Luftwaffe Colours 1935-1945, Hikoku Publ., M.Ullmann,
- Luftwaffe Colours vol.1, sec 1, JGDWAFFE, E.Mombeck,
- Flugzeug Classic Extra MESSERSCHMITT Bf 109 teil 1,
- Flugzeug Classic 1/2007
- Aero Journal N 18

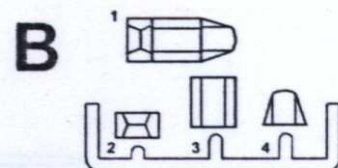
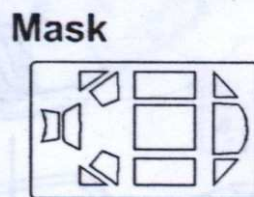
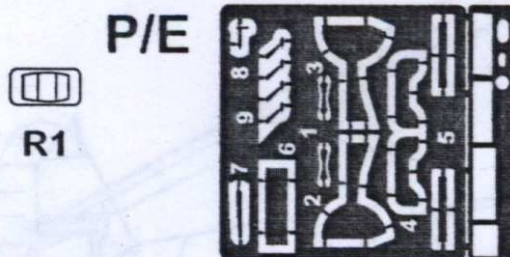
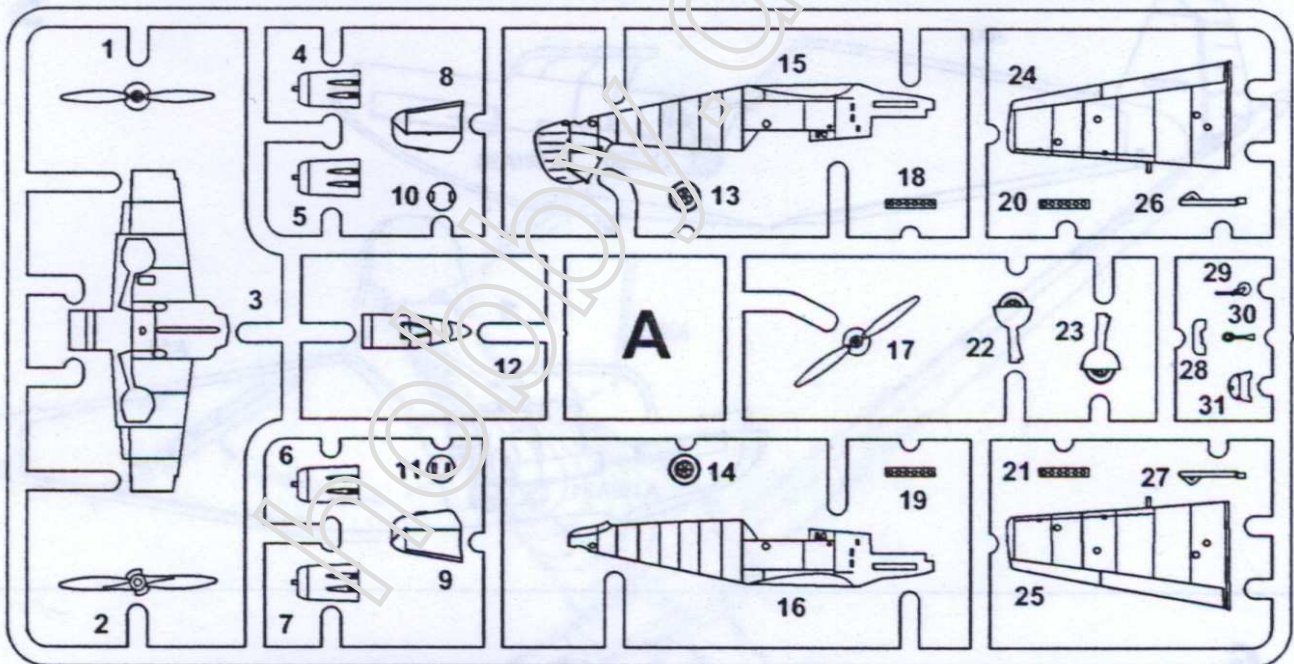

THE CONDITIONAL DENOTATION

УСЛОВНЫЕ ОБОЗНАЧЕНИЯ



BE CAREFUL
ОСТОРОЖНО



DON'T CEMENT
НЕ КЛЕИТЬ



REMOVE
РЕЗАТЬ



SYMMETRICAL
СИММЕТРИЧНО



MAKE TWO
УДВОИТЬ



OPTIONAL
НЕОБЯЗАТЕЛЬНО



BEND
СОГНУТЬ



OPEN WHOLE
СВЕРЛИТЬ



CEMENT
КЛЕИТЬ



VARIANTS
ВЫБОР ВАРИАНТА

1 2

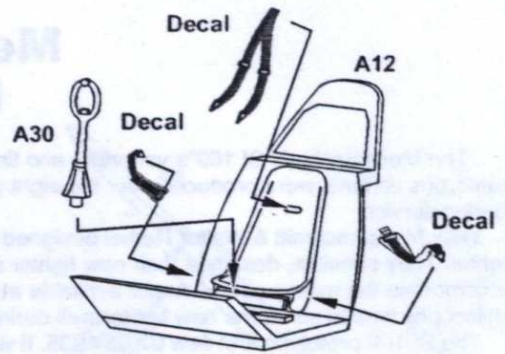
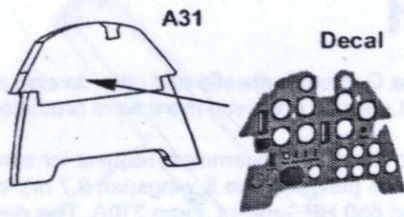

3

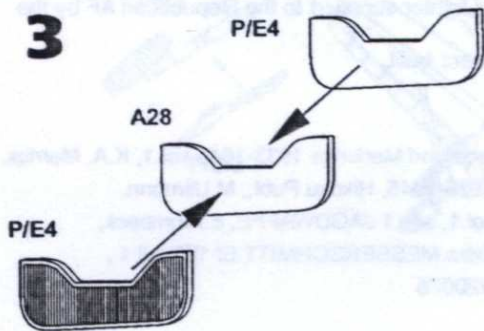

4

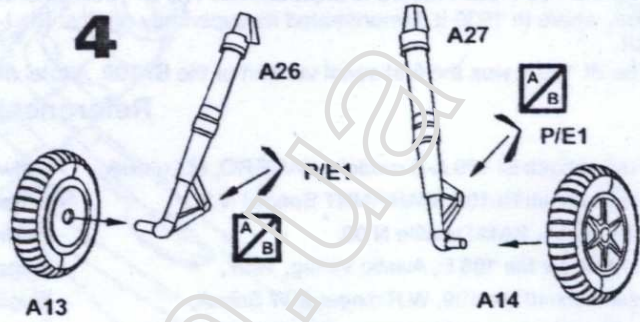

5

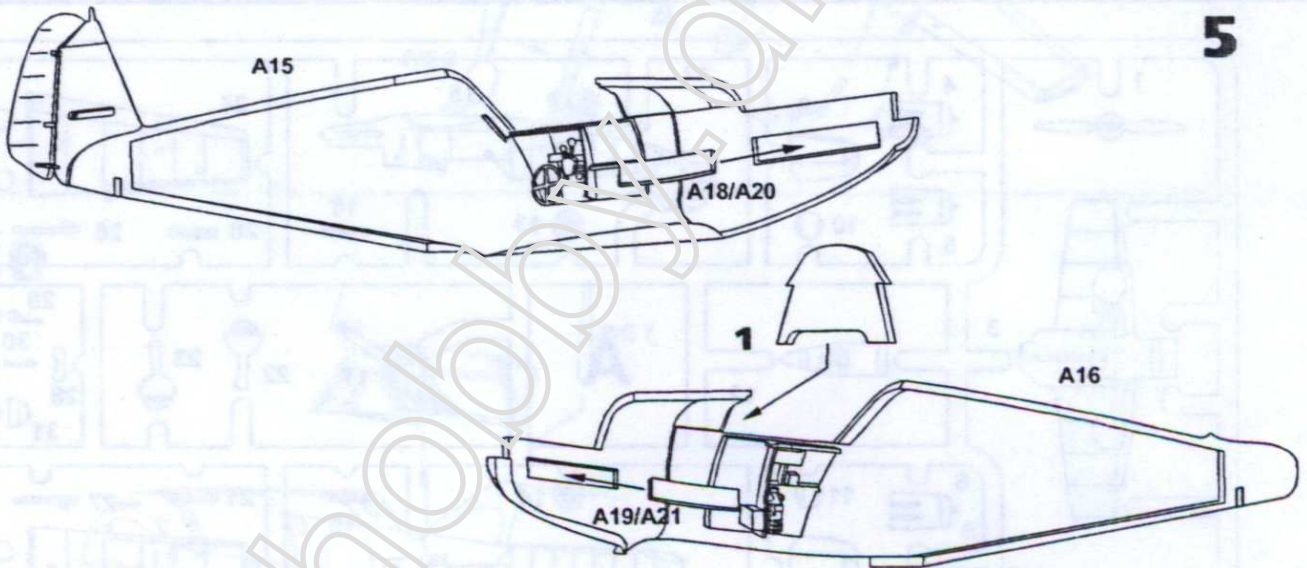

6

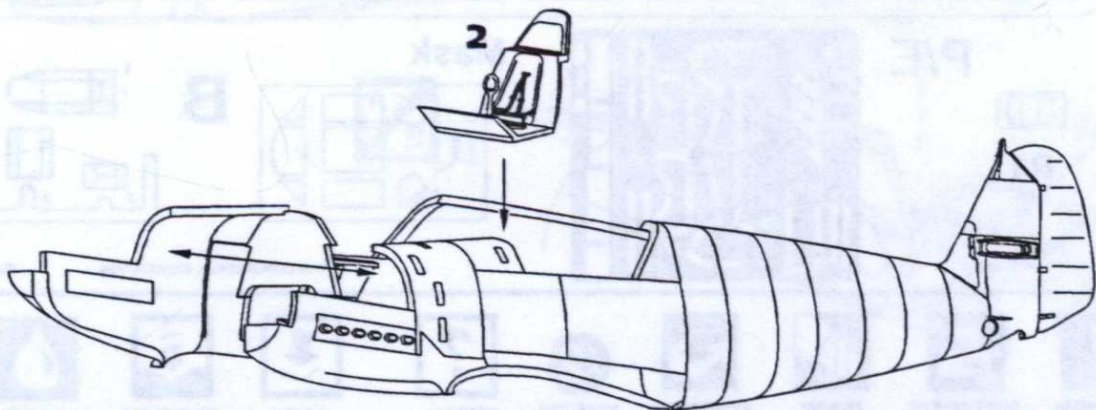

7

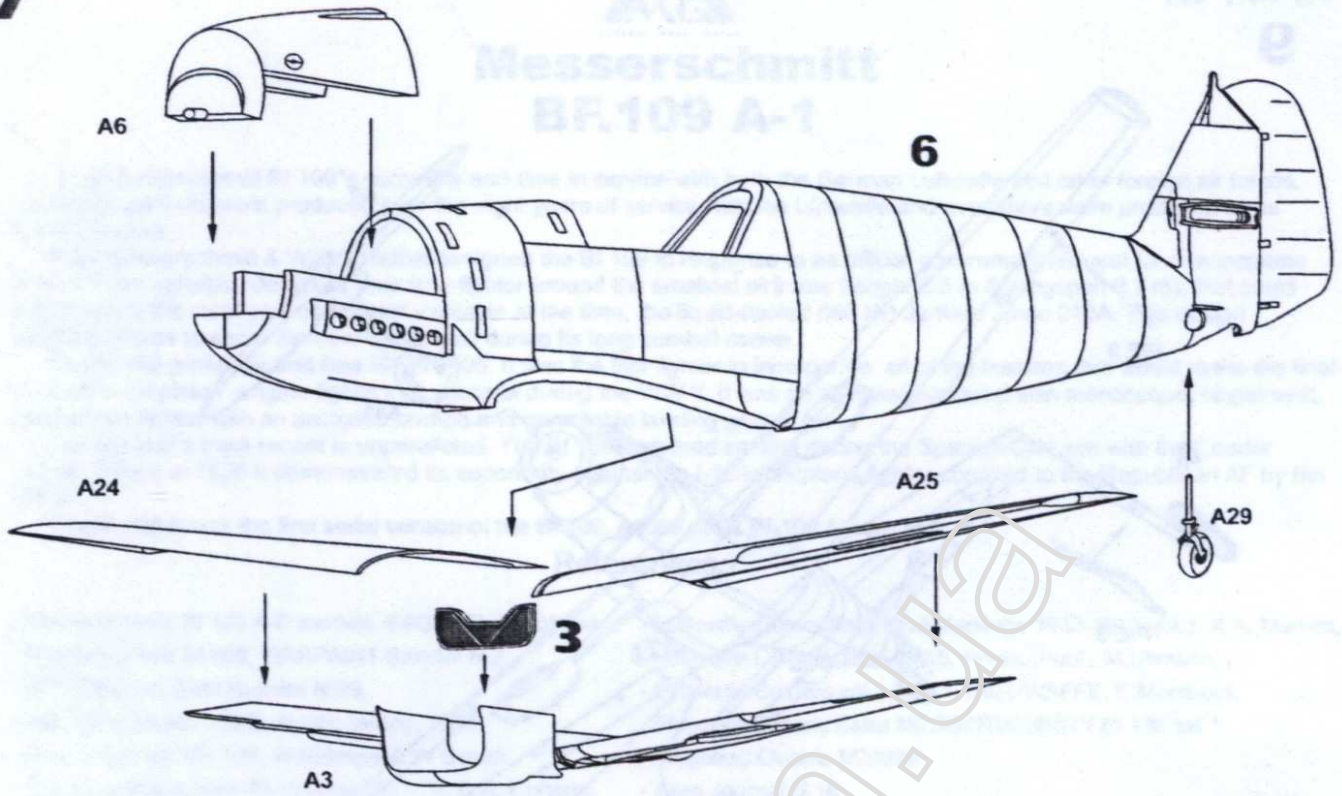

8

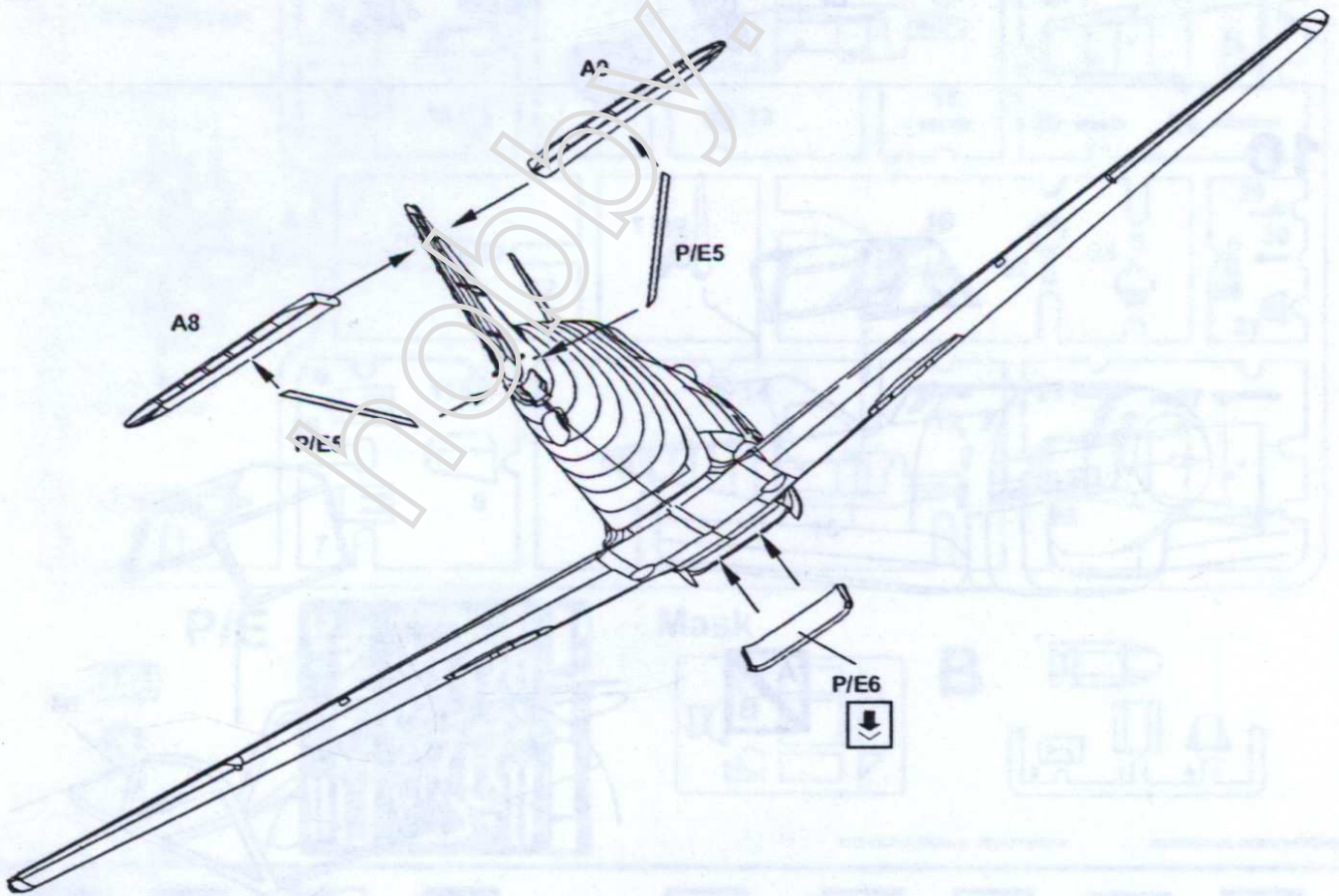

9

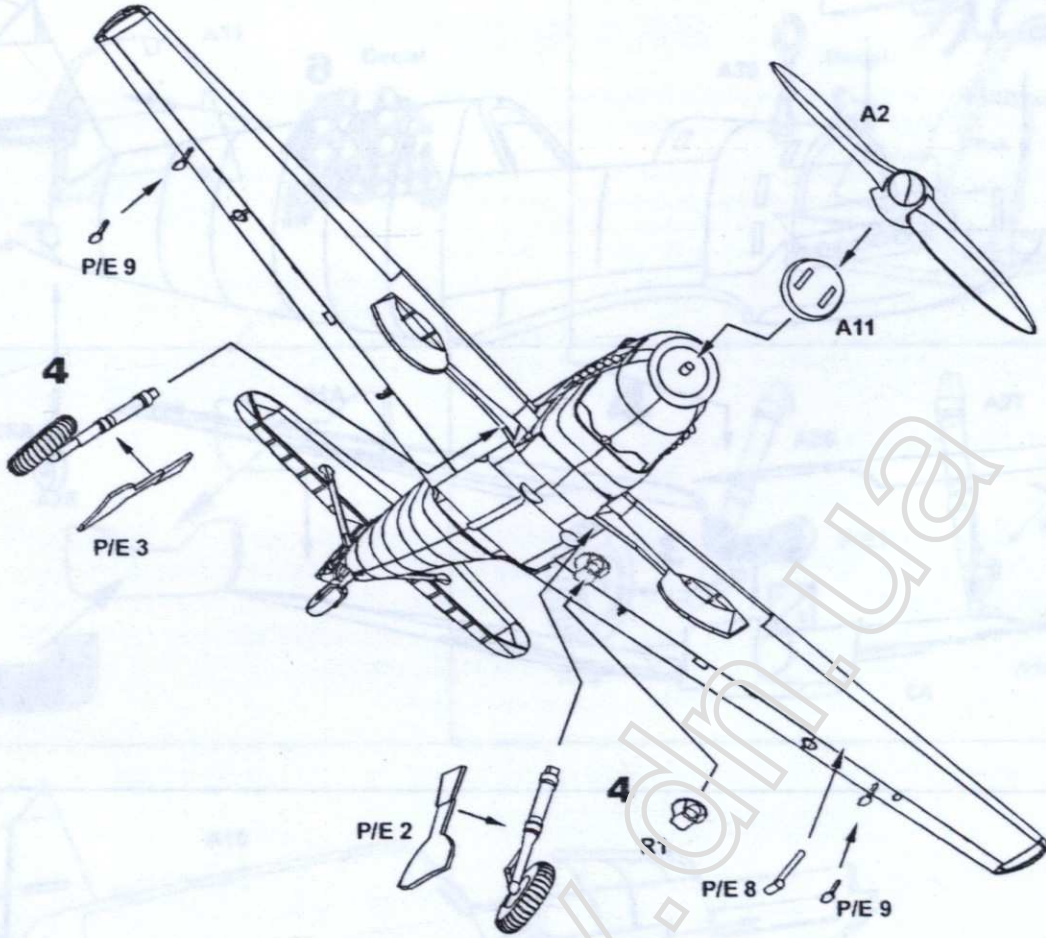

10

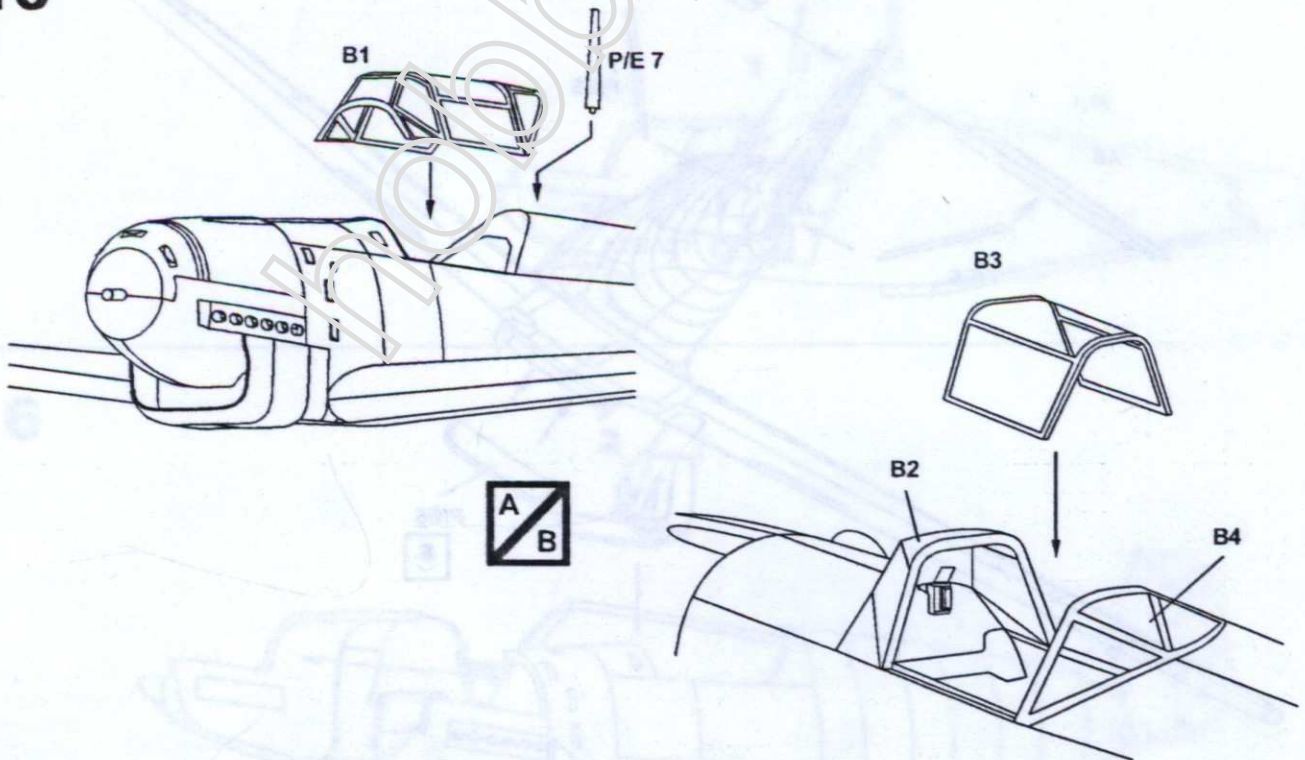

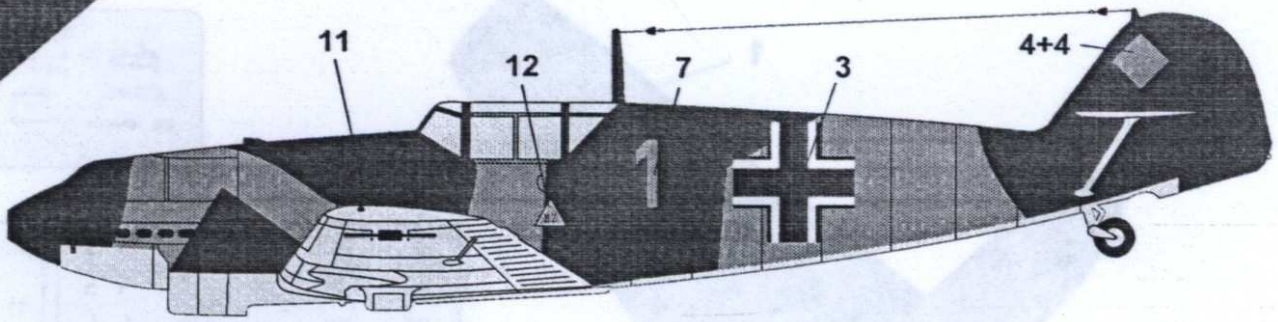

Bf 109 A-1 I/JG136, summer 1937

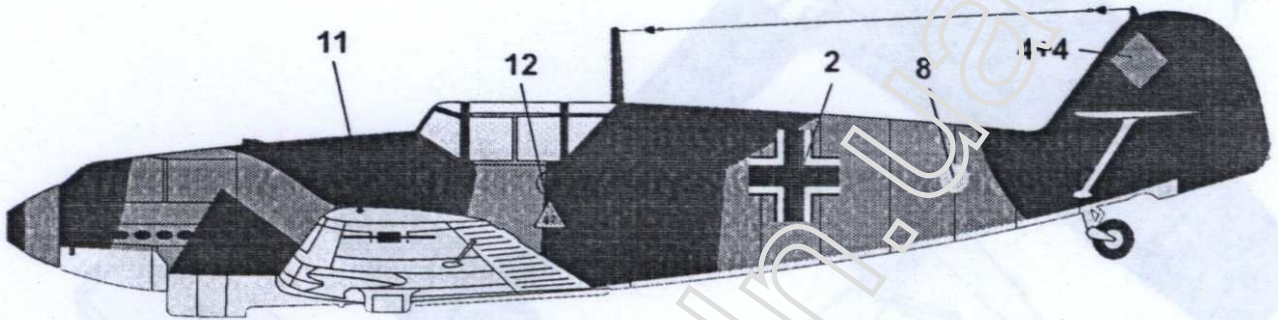

Bf 109 A-1 III/JG132 "Richthofen", Koln, April 1937

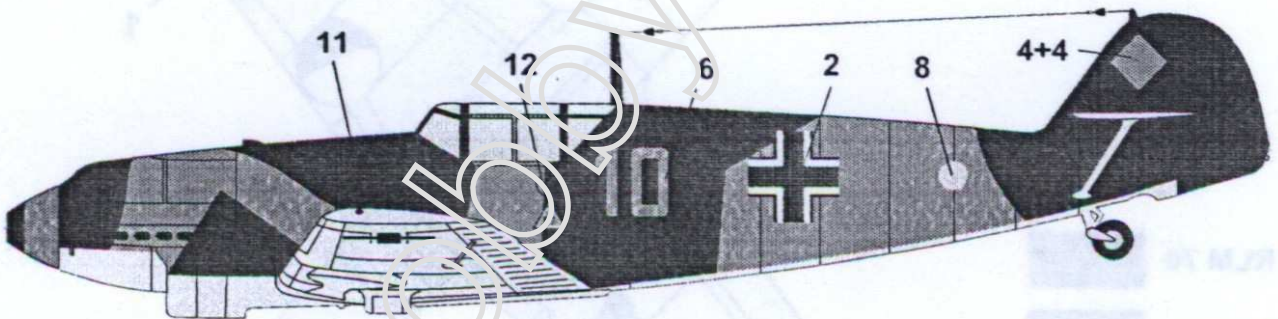

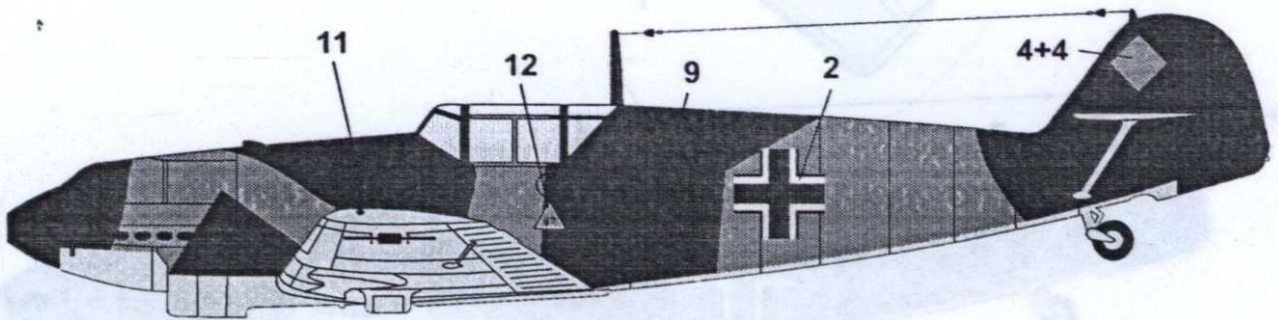

Bf 109 A-1 III/JG132 "Richthofen", Koln, April 1937

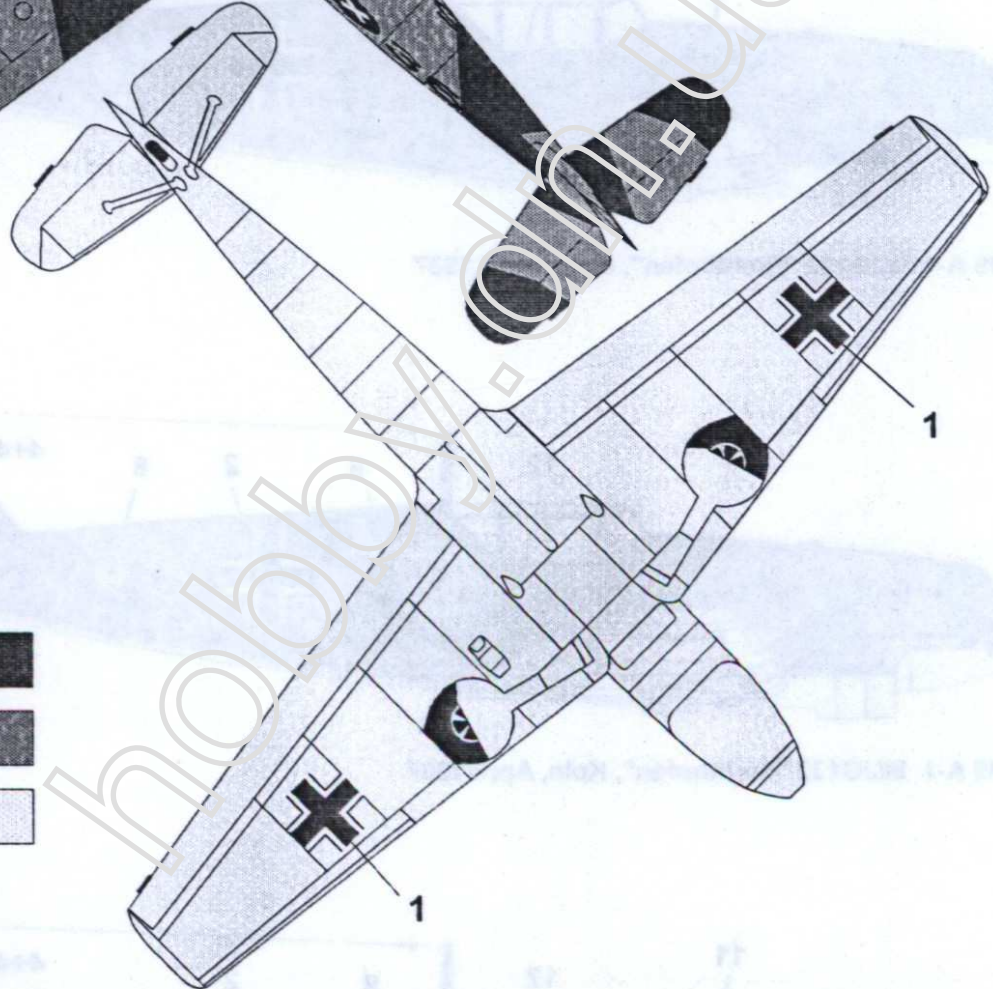
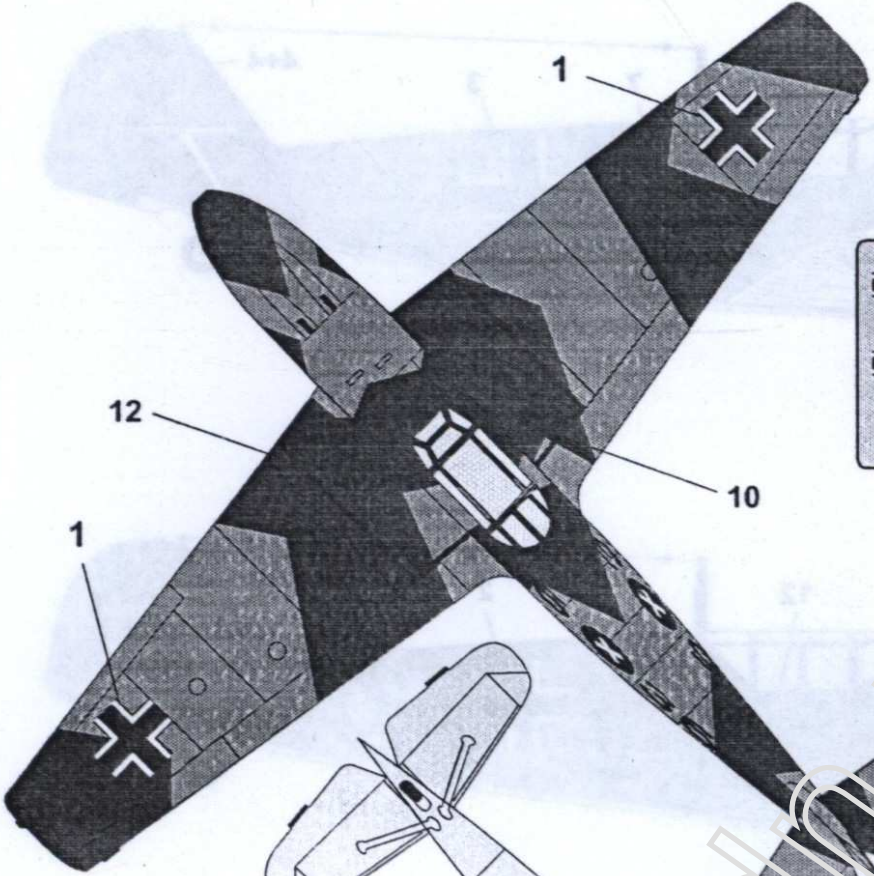
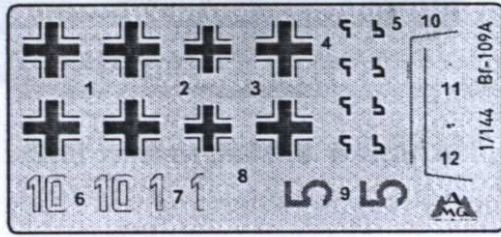
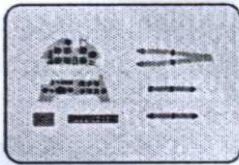

Bf 109 A-1 I/JG134, summer 1937



- RLM 70 
- RLM 71 
- RLM 62 