

# D.510J Japan service

In 1930, aircraft designer E. Dewoitine developed the D.500 fighter design. In november 1933, his company, Construction Aeronautiques Emile Dewoitine, was given a contract for 60 examples. The first production aircraft took flight on 29.11.1934, and in july 1935 D.501 aircraft entered service with the french AF, followed by the D.510 variant in october 1936.

Dewoitine D.500 was an all-metal, open-cockpit, fixed-undercarriage monoplane fighter aircraft. In total, an estimated 381 aircraft were built.

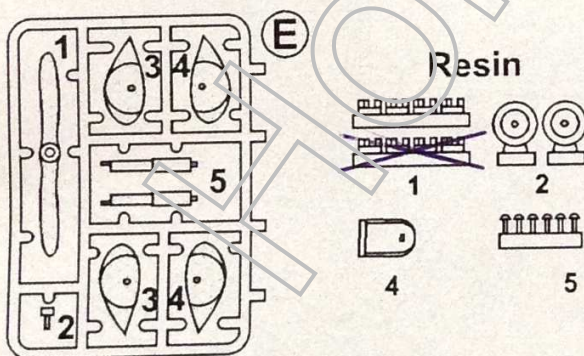
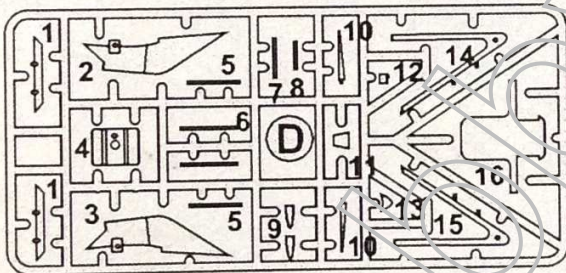
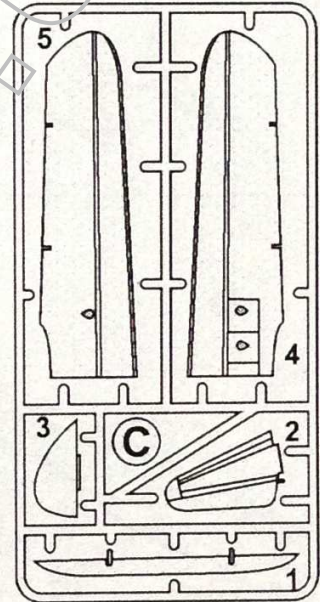
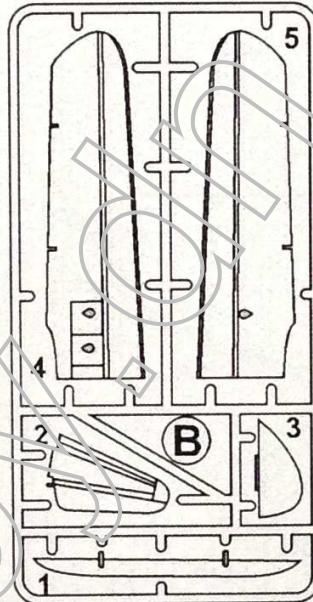
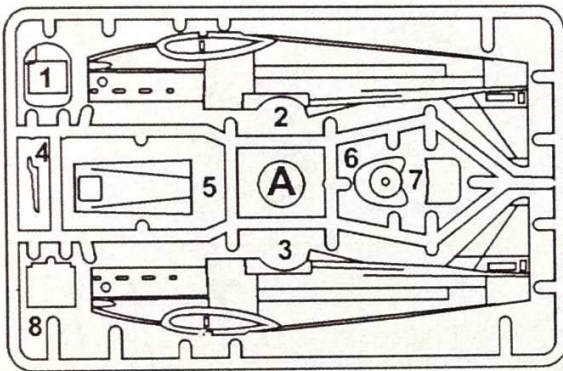

PE

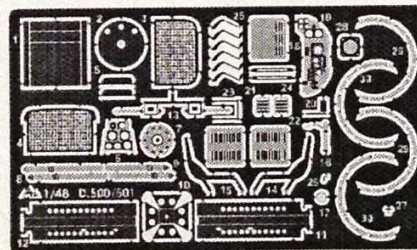

Film



THE CONDITIONAL DENOTATION

УШТОЧЕННЯ ДОЗНАЧЕННЯ



BE CAREFUL  
ОСТОРОЖНО



DON'T CEMENT  
НЕ КЛЕИТЬ



REMOVE  
РЕЗАТЬ



SYMMETRICAL  
СИММЕТРИЧНО



MAKE TWO  
УДОБИТЬ



OPTIONAL  
НЕОБЯЗАТЕЛЬНО



BEND  
СОГНУТЬ



OPEN WHOLE  
СВЕРЛИТЬ



CEMENT  
КЛЕИТЬ



VARIANTS  
ВЫБОР ВАРИАНТА

ASSEMBLY MANUAL

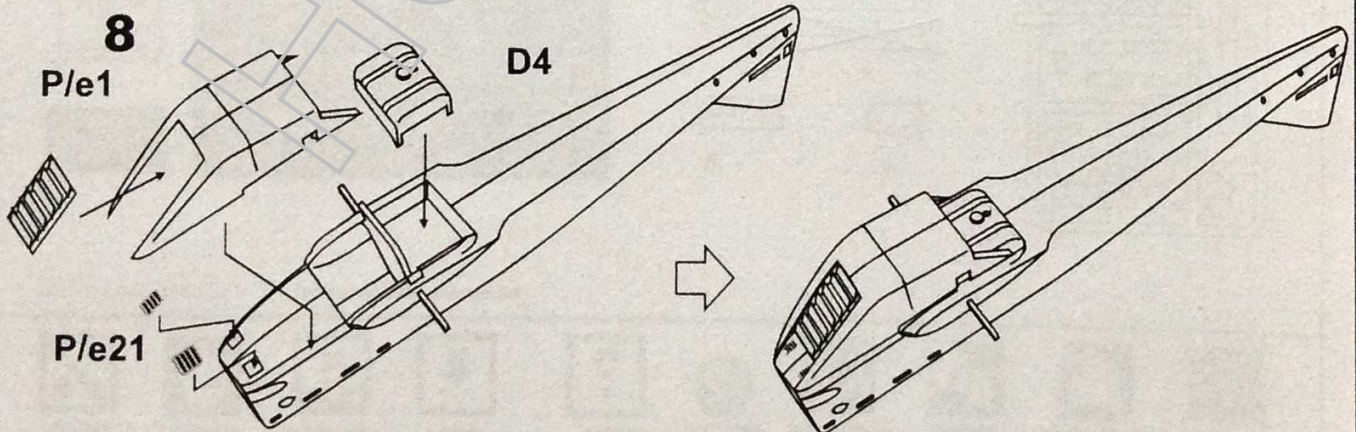
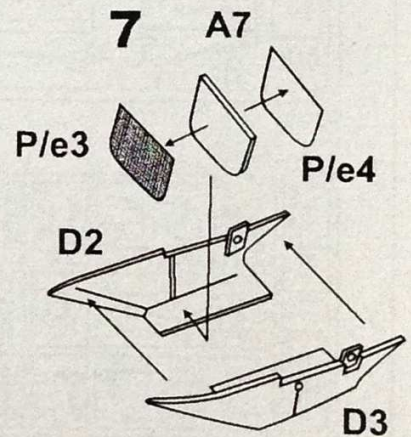
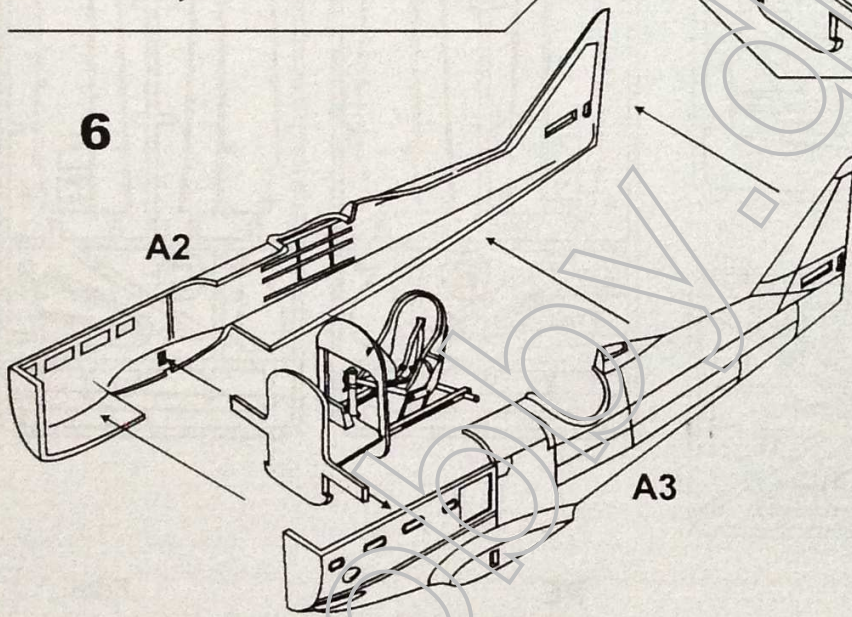
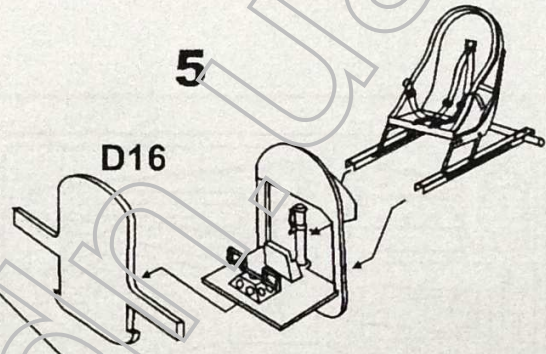
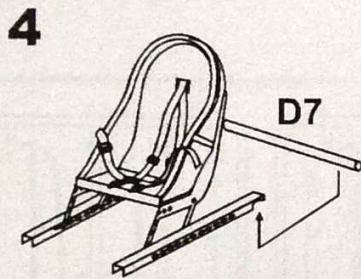
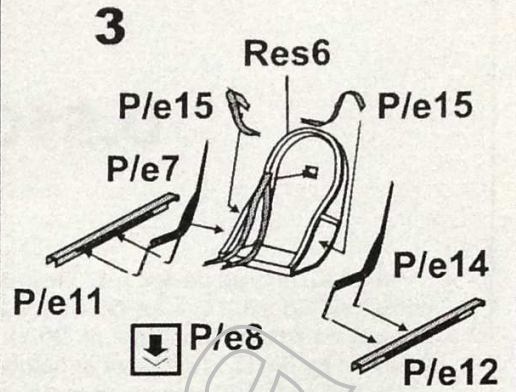
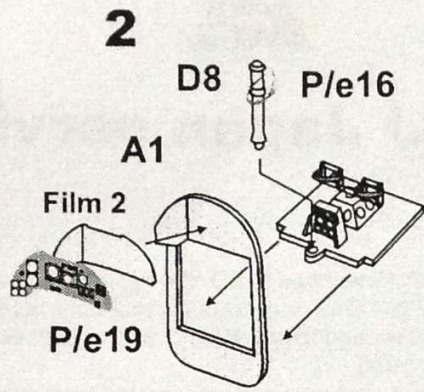
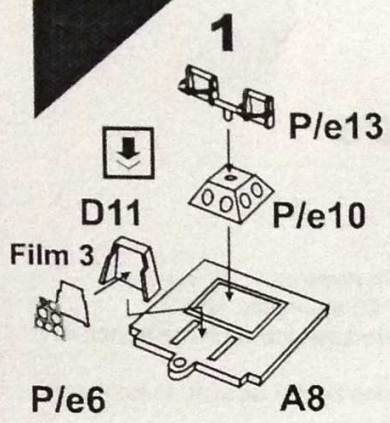

9

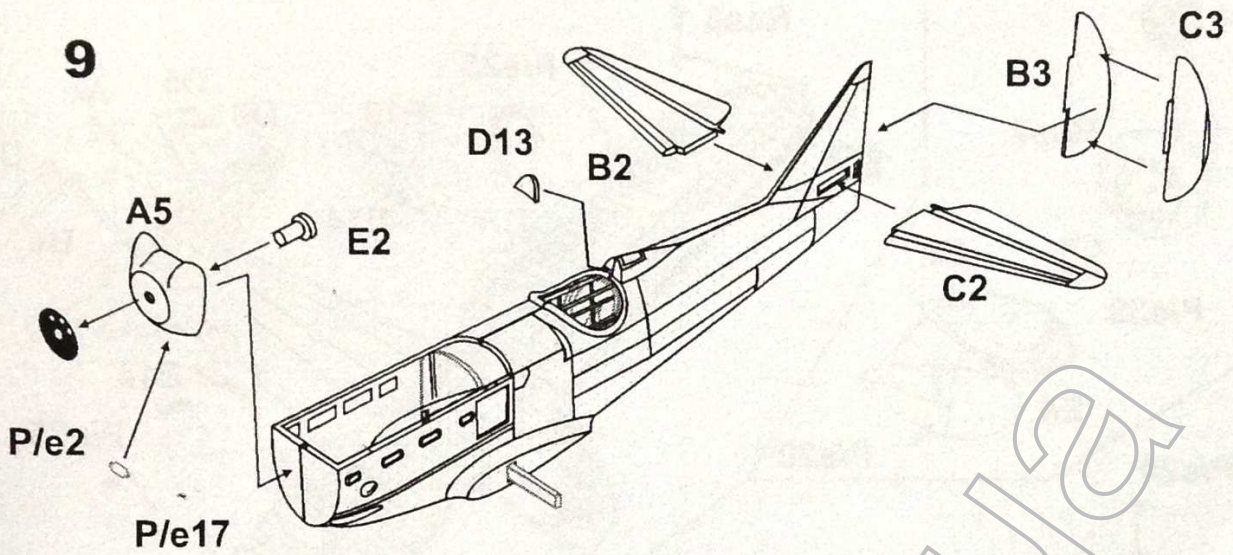

10

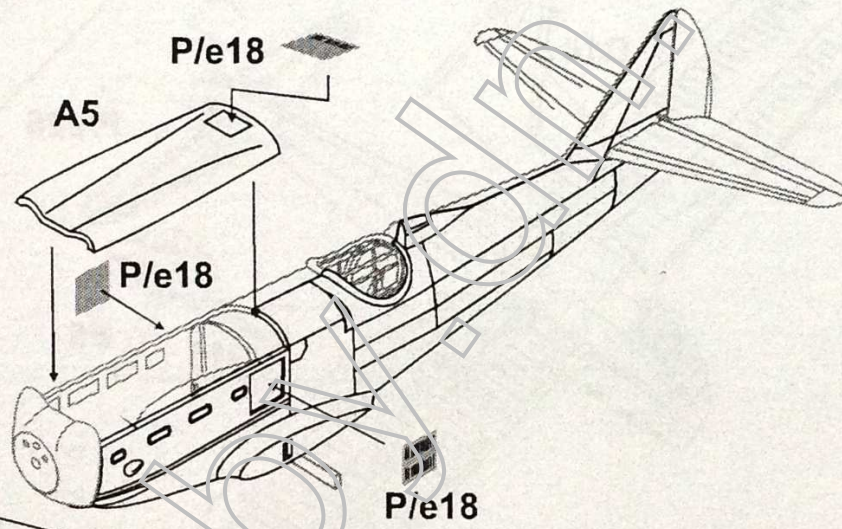

11

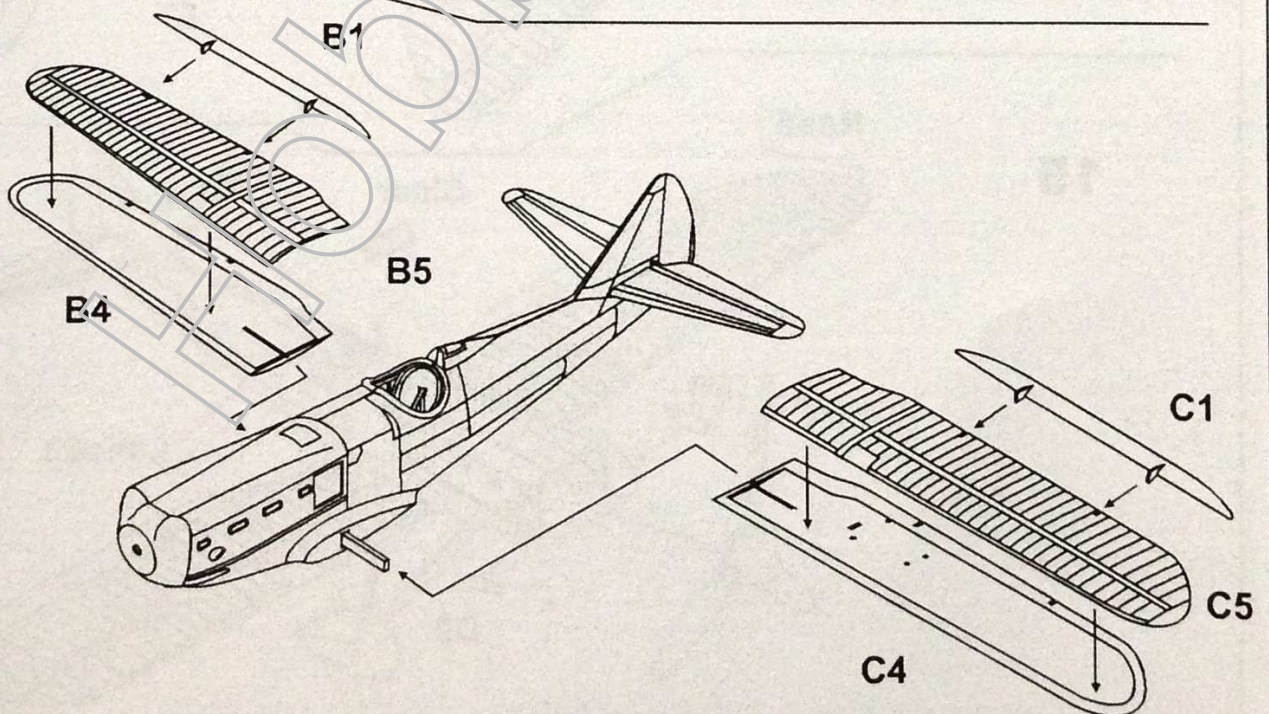

12 **x2**

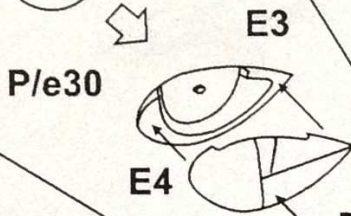

13

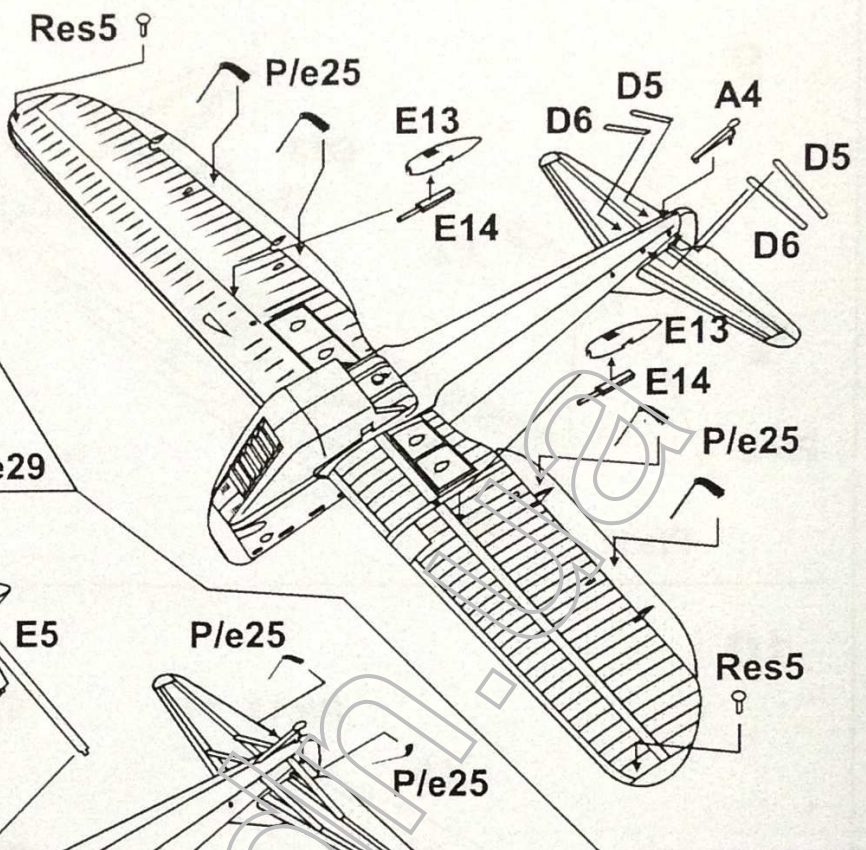

P/e20

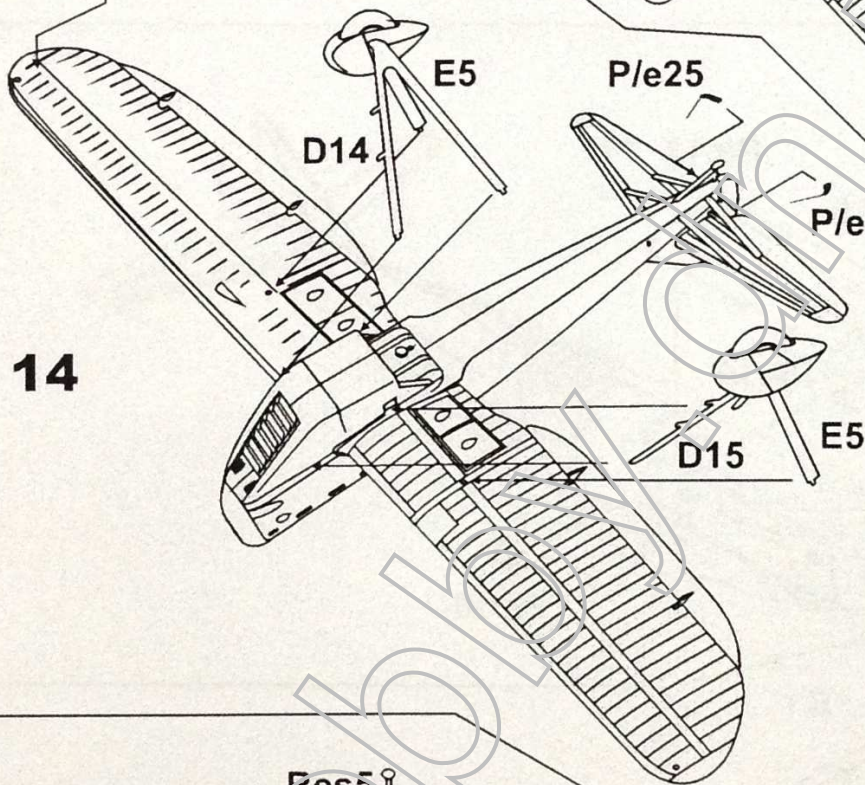

14

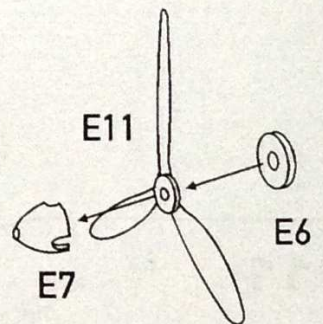

15

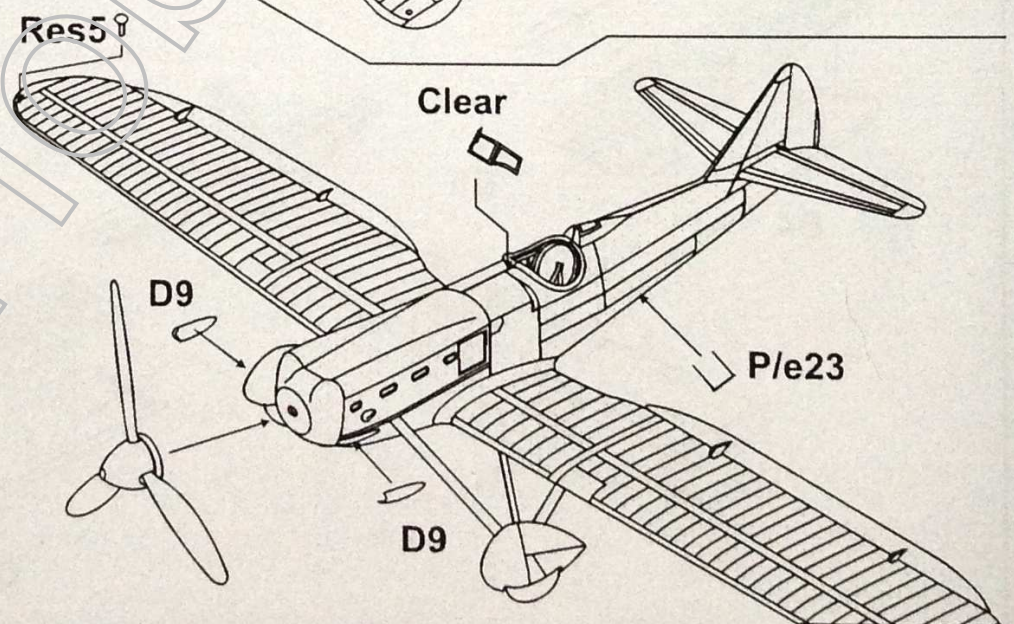

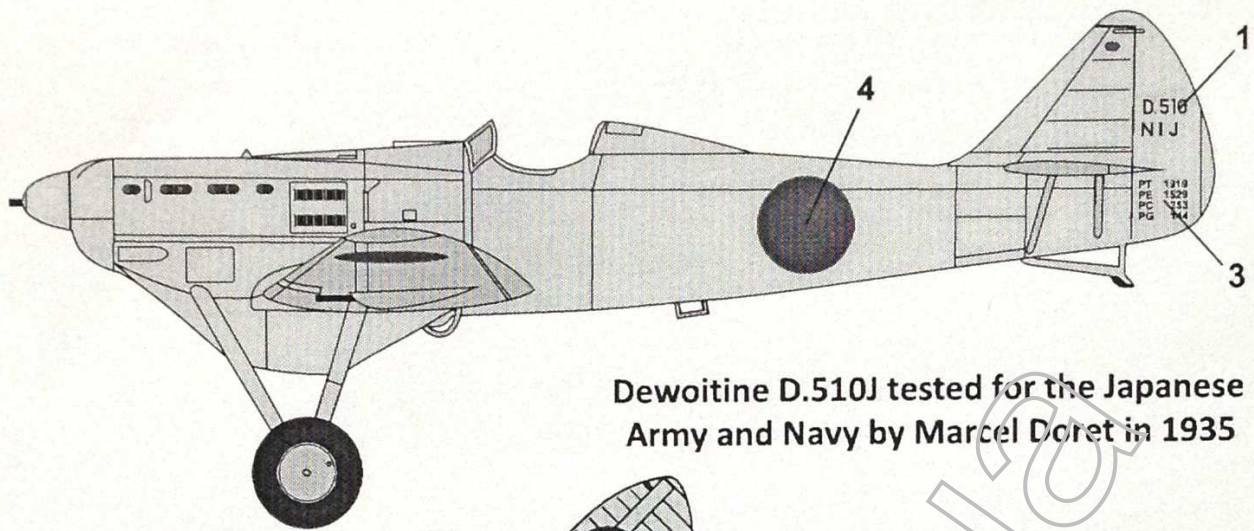

Dewoitine D.510J tested for the Japanese Army and Navy by Marcel Doret in 1935

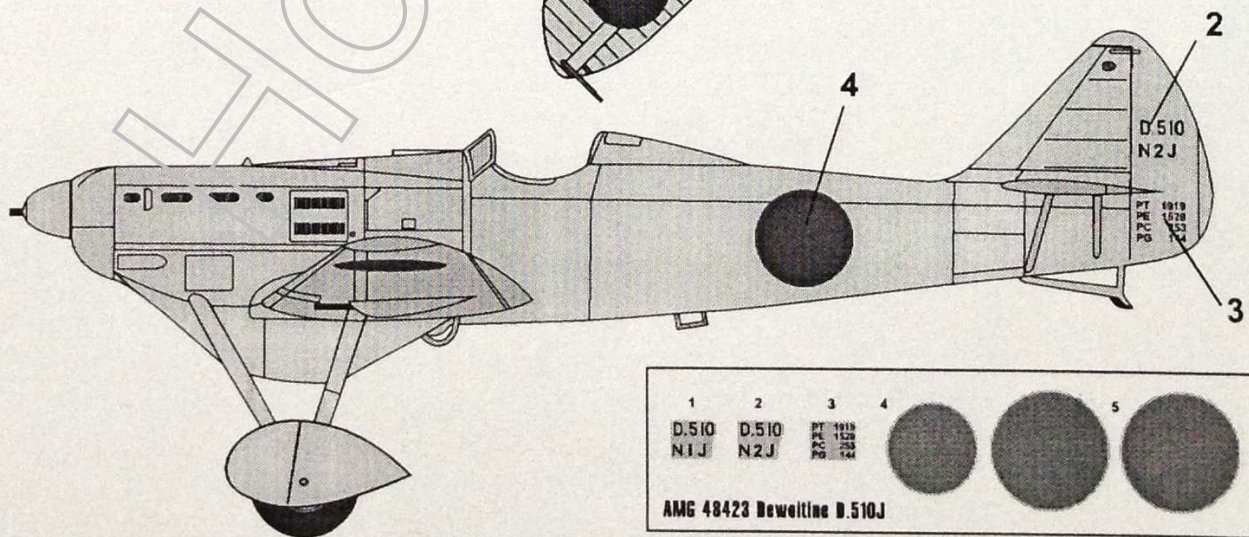
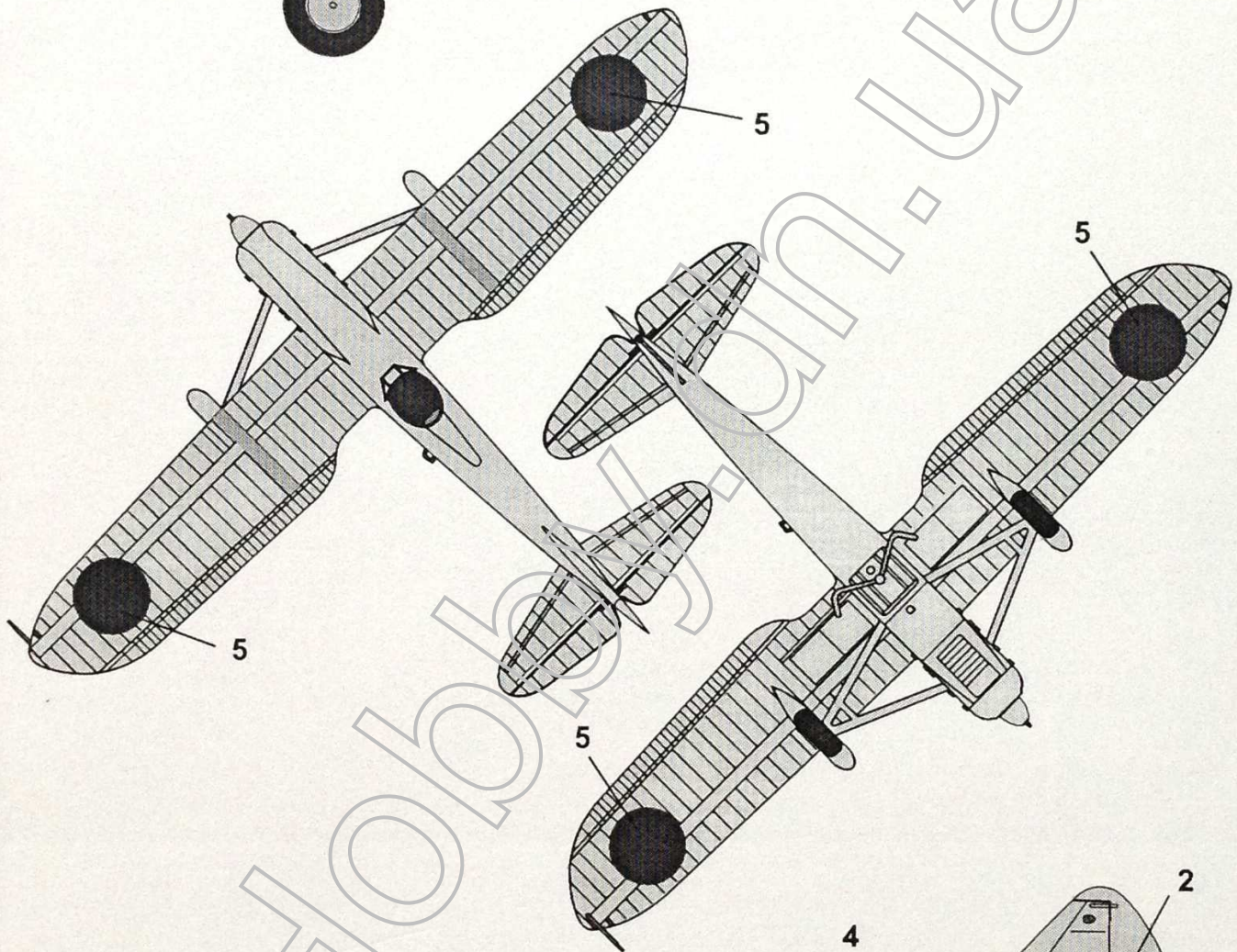

1	2	3	4	5
D.510 NIJ	D.510 N2J	PT 1919 PE 1529 PC 153 PG 154		

AMG 48423 Dewoitine D.510J