

PLASTIC MODEL KITS
LIMITED EDITION
CAT.NO.72018



WIDTH : 478 mm
LENGTH : 514 mm
PARTS : 518 pieces
SCALE:1/72



The largest helicopter in the world V-12 of M.L. Mile design conducted its first flight in spring 1967. 8 world records were achieved on this helicopter. In June 1971 the helicopter was first exhibited at International aviation saloon in Le Bourge, where the visitors were impressed by its dimensions and technical parameters. The wingspan reached 67 meters, fuselage length comprised 37 meters, height - 4,4 meters, chassis wheels diameter - 1,7 meters, maximum weight - 105 tons. The idea of building heavy cargo helicopter first appeared in 1960 as one of the components of quick nuclear war plan. It was intended that his mission would be to deliver missiles, as well as bulky loads to the launching point. The production of V-12 turned out to be too expensive, and regardless of all the achievements, the helicopter has not been produced serially. The largest helicopter in the world, having also the highest loading capacity, is currently exhibited in Aviation Museum in Monino.



Разработанный под руководством В.Л. Миля, самый большой вертолет в мире Ми-12 (В-12) совершил свой первый полет весной 1967 года. На нем были поставлены 8 мировых рекордов. Впервые вертолет был представлен широкой публике в 1971 году на Международном авиасалоне в Ле Бурже, где он поразил посетителей своими размерами и техническими характеристиками. Размах крыла - 67 м., длина фюзеляжа - 37 м., высота - 4,4 м., диаметр шасси - 1,7 м., максимальный вес - 105 тонн. Идея создания тяжелого грузовой вертолета впервые возникла в 1960 году, как часть ядерного военного плана - он должен был обеспечить доставку таких объемных грузов как ракеты к пусковым установкам. Производство В-12 было прекращено как очень дорогостоящее и, несмотря на все достижения, машина не пошла в серийное производство. Теперь самый большой в мире и обладающий наивысшей грузоподъемностью вертолет является экспонатом Авиационного музея в Монино.

The model is executed on technology short run and is intended only for experienced modelers
Word-wide distributor for AMODEL kits :
IBG, Warszawa, Poland
Fax:(4822)842-56-29 ; E-Mail:ibgso@ibg.com.pl

Модель выполнена по технологии short run и предназначена только для опытных моделеров
Дистрибьютор моделей AMODEL :
IBG, Варшава, Польша
Факс:(4822) 842-56-29 ; E-Mail:ibgso@ibg.com.pl



USED SYMBOLS / ИСПОЛЗУЕМЫЕ СИМВОЛЫ

1

STAGES OF ASSEMBLY
ЭТАПЫ СБОРКИ

1

NUMBER PARTS
НОМЕР ДЕТАЛИ

1

APPLY DECALS
НАНЕСТИ ДЕКАЛЬ

A

TO PAINT
ОКРАСИТЬ

G

GLUE
КЛЕИТЬ

S

TO USE SUPERGLUE™
ИСПОЛЗОВАТЬ КЛЕЙ SUPERGLUE™

X

DONT GLUE
НЕ КЛЕИТЬ

?

OPTIONAL
НА ВЫБОР

H

MAKE A HOLE
ВЫПОЛНИТЬ ОТВЕРСТИЕ

K

DETACH WITH KNIFE
ОТДЕЛИТЬ НОЖОМ

2x

QUANTITY OF OPERATIONS(PARTS)
КОЛИЧЕСТВО ОПЕРАЦИЙ(ДЕТАЛЕЙ)

M

TO MAKE A DETAIL
ИЗГОТОВИТЬ ДЕТАЛЬ



USED PAINTS / ИСПОЛЗУЕМЫЕ КРАСКИ

A

HUMBROL 22
WHITE
БЕЛЫЙ

B

HUMBROL 89
MIDDLE BLUE
ГОЛУБОЙ

C

HUMBROL 14
BLUE
СИНИЙ

D

HUMBROL 19
RED
КРАСНЫЙ

E

HUMBROL 33
BLACK
ЧЕРНЫЙ

F

HUMBROL 64
LIGHT GREY
СВЕТЛО СЕРЫЙ

G

HUMBROL 87
GREY
СЕРЫЙ

H

HUMBROL 147
LIGHT GREY
СВЕТЛО СЕРЫЙ

J

HUMBROL 145
MEDIUM GREY
СРЕДНЕ-СЕРЫЙ

K

HUMBROL 27004
GUN METAL
СТАЛЬНОЙ СЕРЫЙ

АЭРОФЛОТ
АЭРОФЛОТ
Н-833 · Н-833
СССР
21142

MI1 MI-12 (V-12)

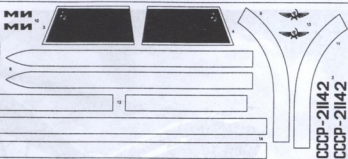

DECALS FOR ONE
VERSION OF COLOURING
ДЕКАЛЬ ДЛЯ ОДНОГО
ВАРИАНТА ОКРАСКИ

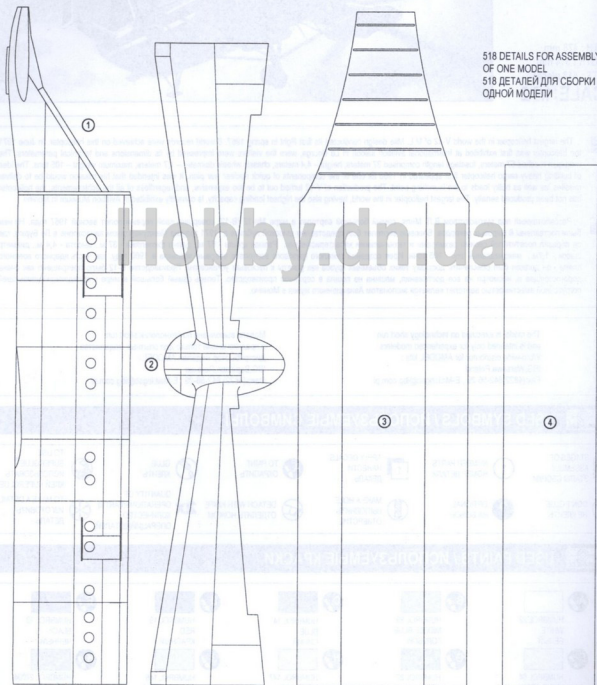

518 DETAILS FOR ASSEMBLY
OF ONE MODEL
518 ДЕТАЛЕЙ ДЛЯ СБОРКИ
ОДНОЙ МОДЕЛИ

Hobby.dn.ua

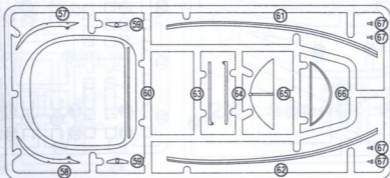
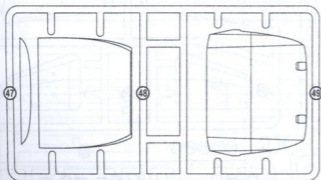
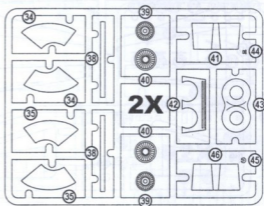
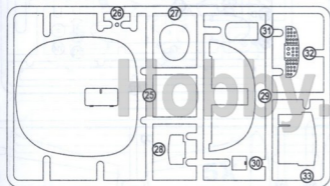
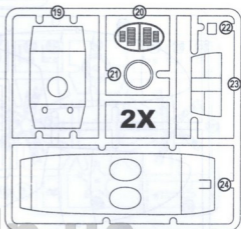
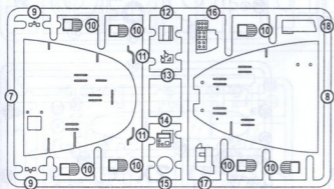
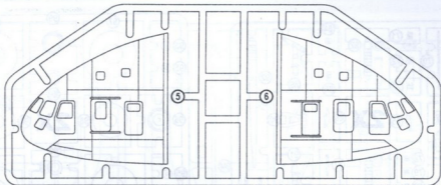

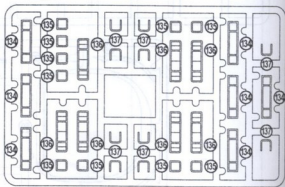
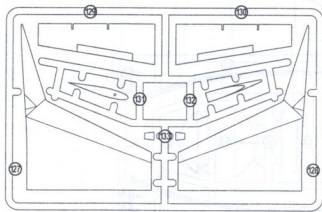
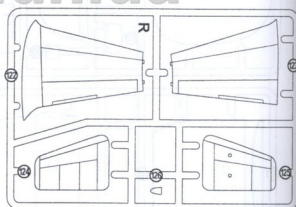
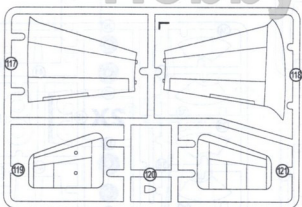
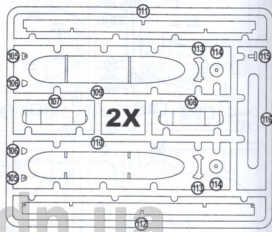
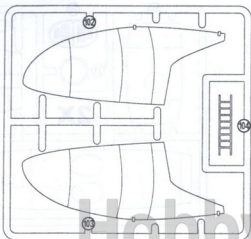
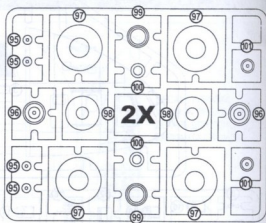
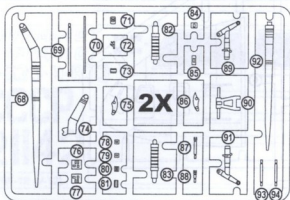

Hobby.on.ua

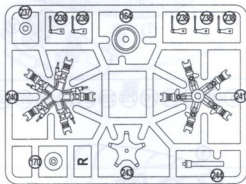
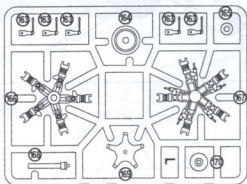
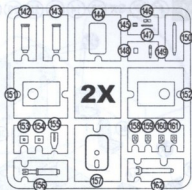
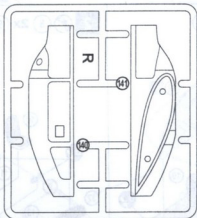
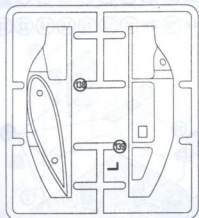

5X

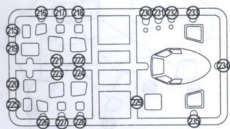
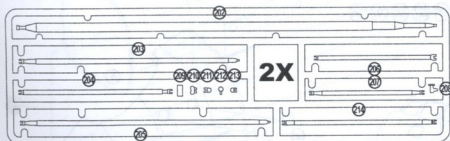
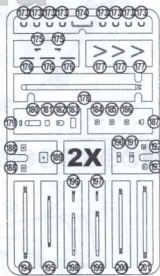

2X

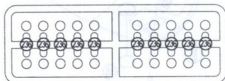

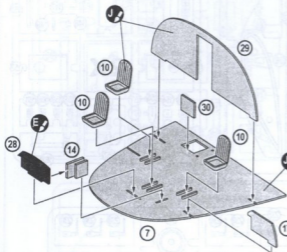
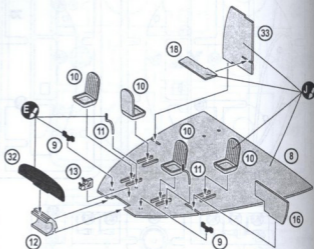
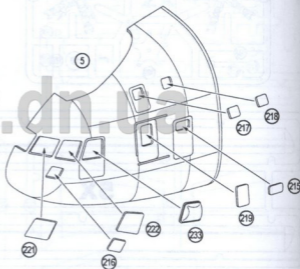
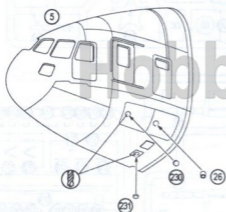
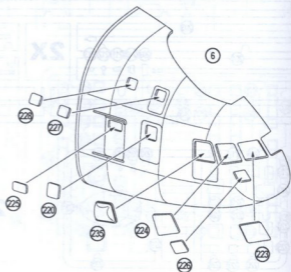
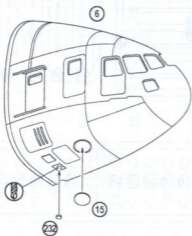
1 7 3x 10 14 17 28 29 30

2 8 2x 9 4x 10 2x 11 12 13 16 18 32 33

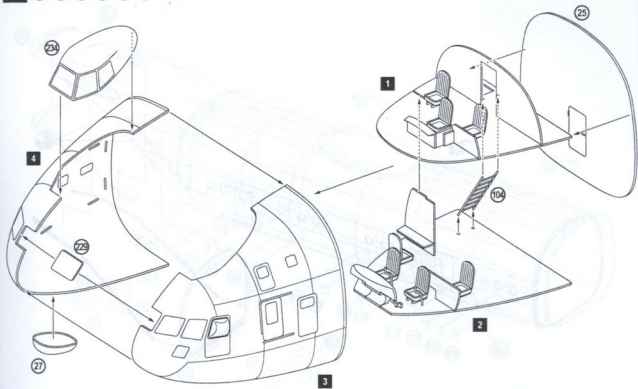
3 5 26 215 216 217 218 219 221 222 230 231 233

4 6 15 220 223 224 225 226 227 228 232 235

5 25 27 104 229 234 1 2 3 4

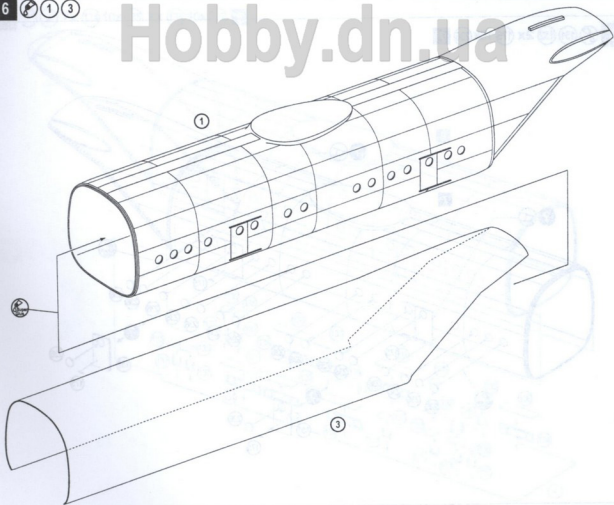

6 1 3

Hobby.dn.ua



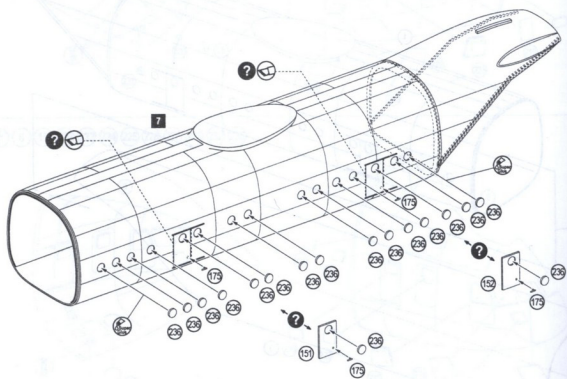
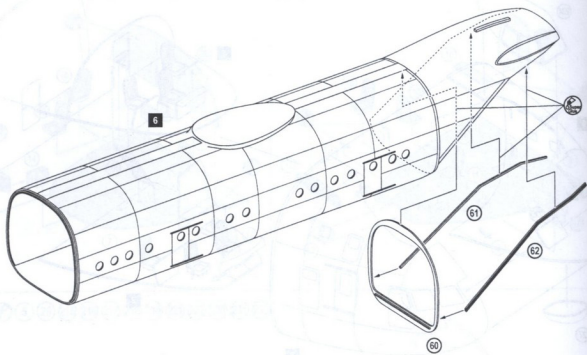

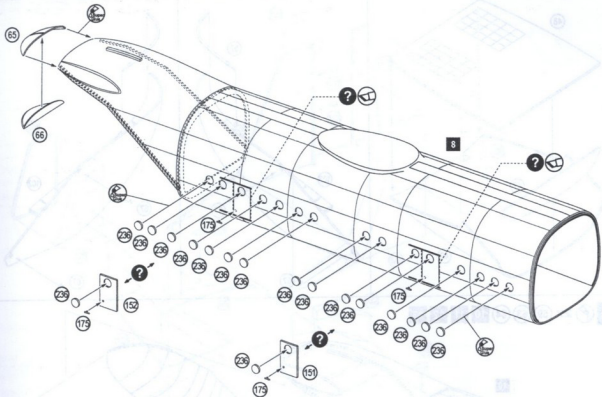

9 65 66 151 152 2x 175 15x 236 8

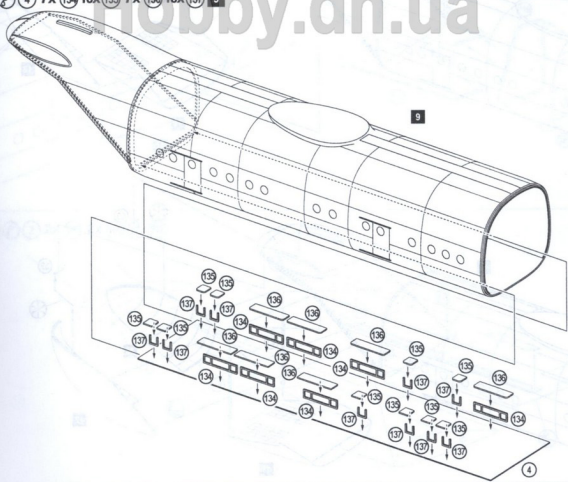

10 4 7x 134 10x 135 7x 136 10x 137 9



11  47 48 49

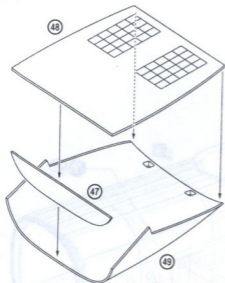

12  57 2x 67 103

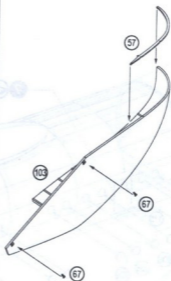

13  58 2x 67 102

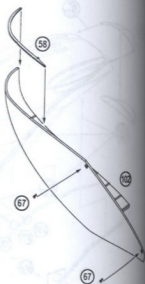

14  2x 59 63 64 10 11 12 13

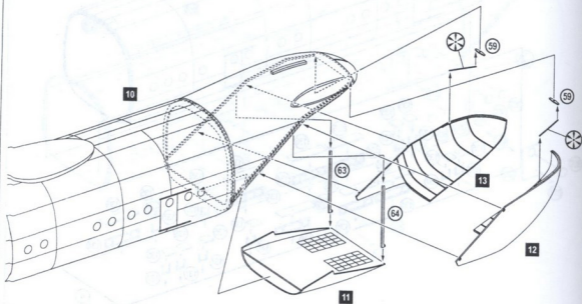
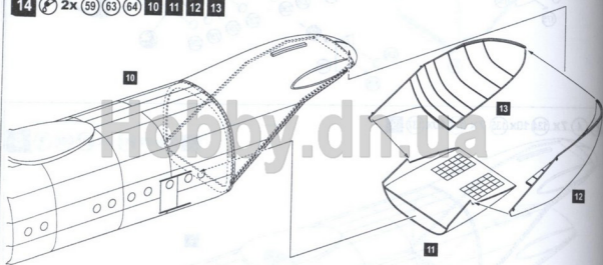

15  117 118 119 120 121 122 123 124 125 126 127 128 129 130 131 132 2x 133 14

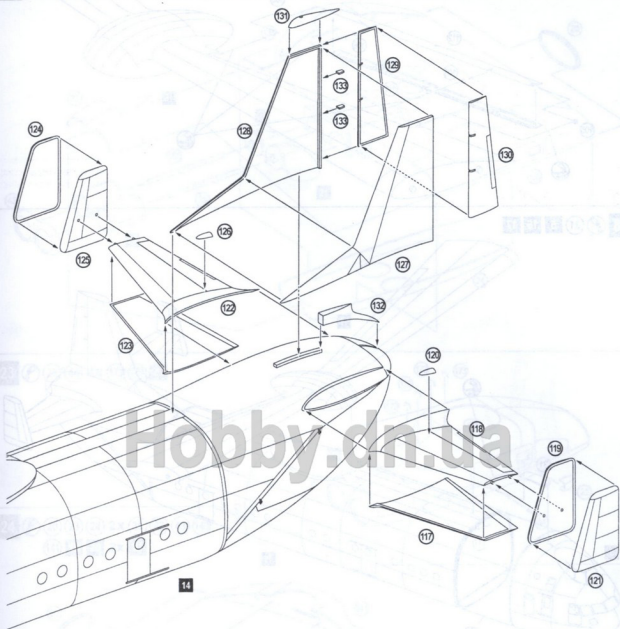

16  2 2x 105 2x 106 111 112

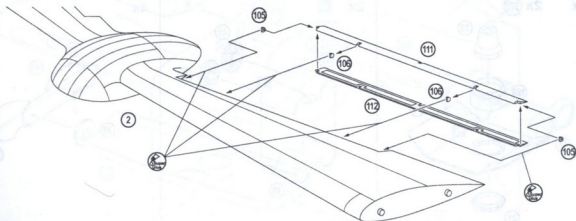

17 2x (105) 2x (106) (111) (112) **16**

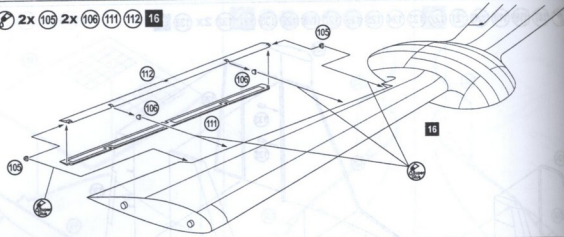

18 (31) **5** **15** **17**

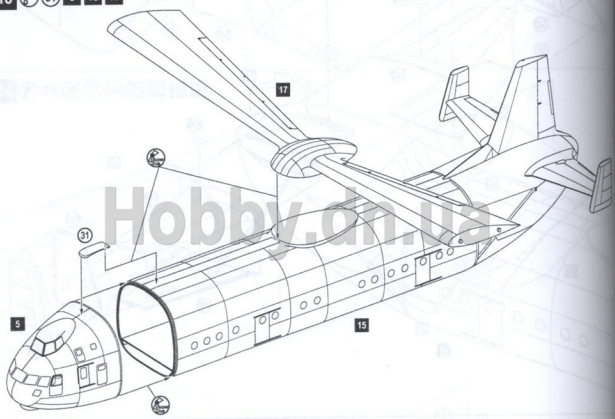

19 2x (19) 2x (21) 2x (164)
2x 2x (170)

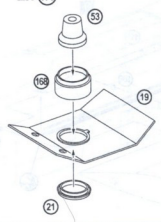

20 4x (40) 2x (41) 2x (46)
2x

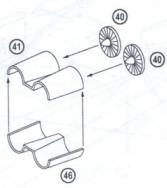

21 4x (34) 4x (35) 4x (39)
4x

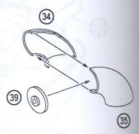

22  20 23 24 2x 38 42 43 138 139 19 20 2x 21

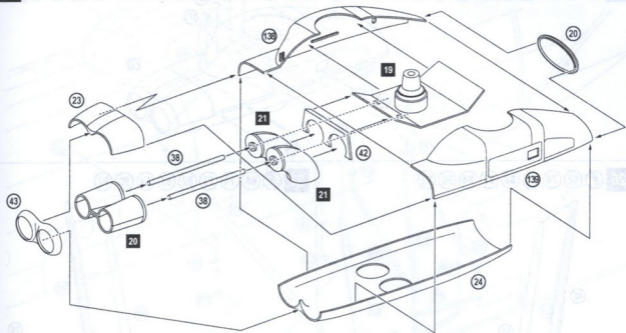

23  22 44 4x 173 174 22

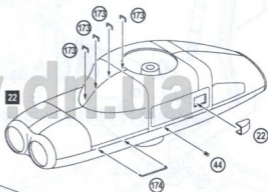

24  20 23 24 2x 38 42 43 140 141 19 20 2x 21

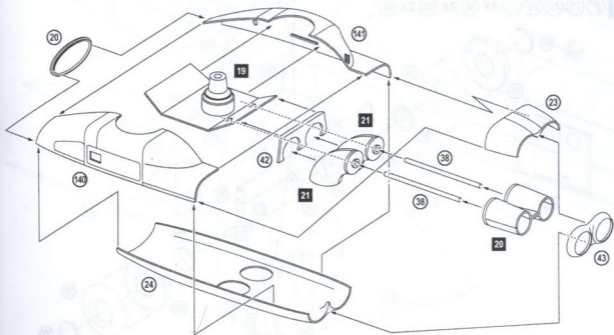

25 22 44 4x 173 174 24

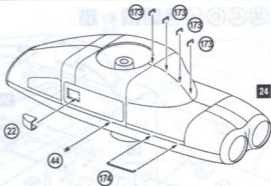

26 68 74 77 82 83 84 90 92

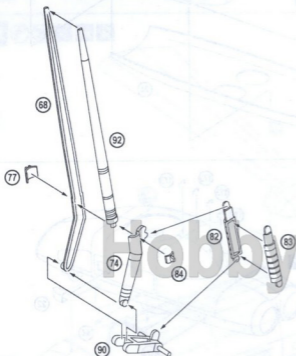

27 68 74 76 82 83 84 90 92

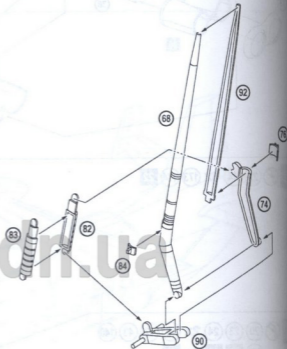

28 75 86 89 91 4x 98 2x 100 2x 101

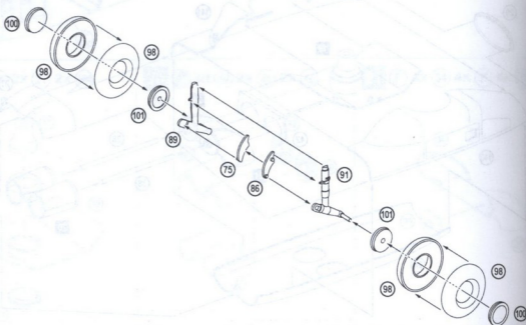

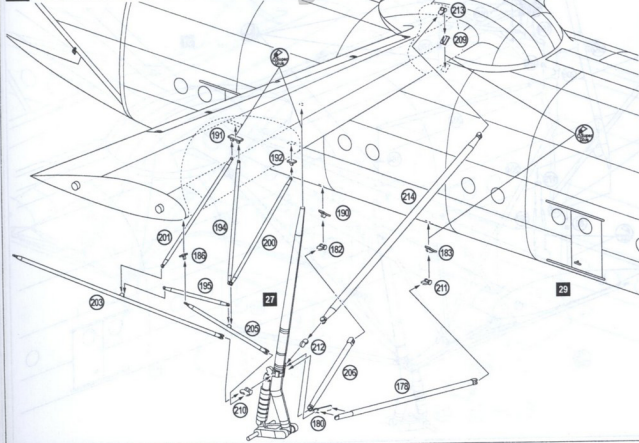
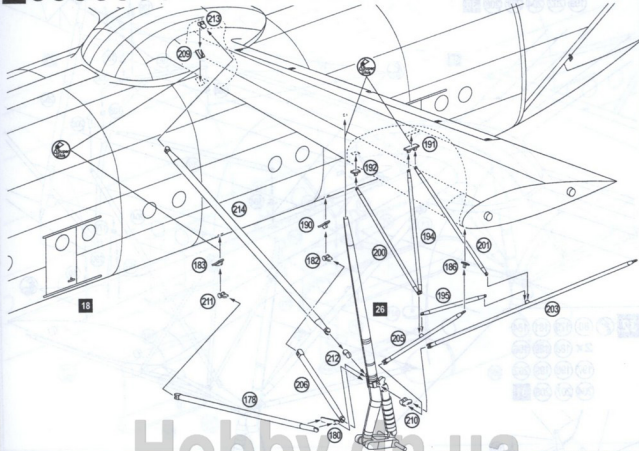

31  80 179 181 184 2x 188 189 196 197 198
199 202 204 207 208 30

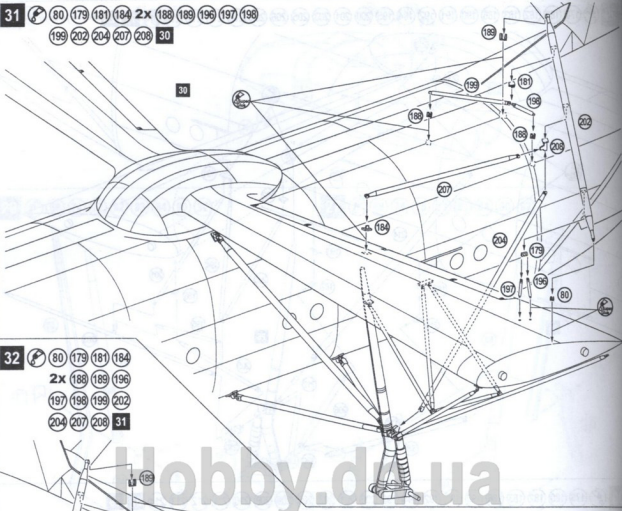

32  80 179 181 184
2x 188 189 196
197 198 199 202
204 207 208 31

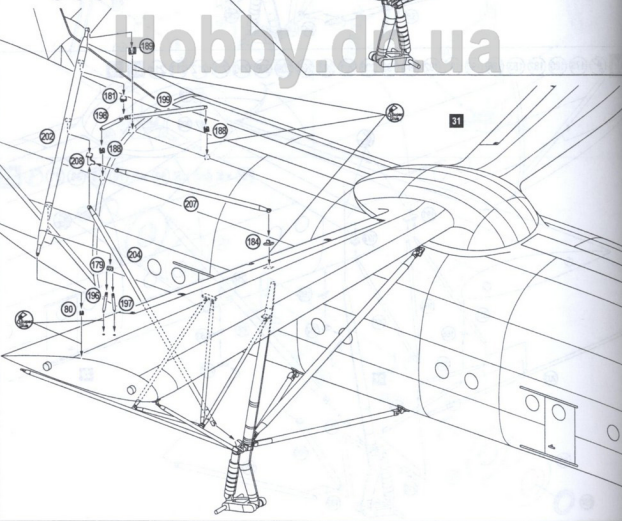

Hobby.dn.ua

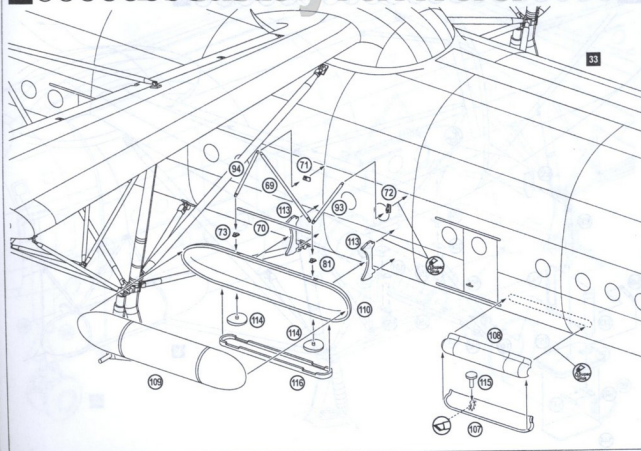
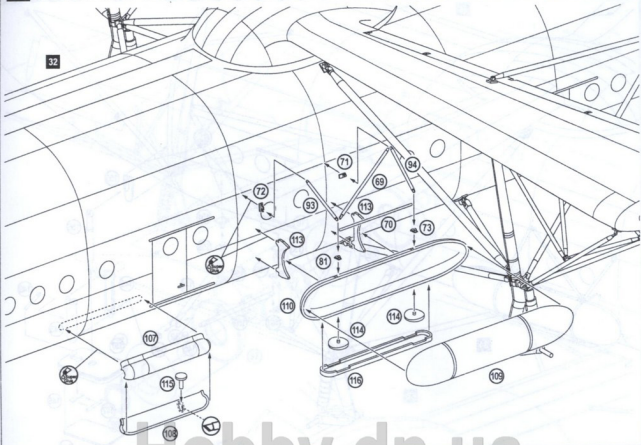

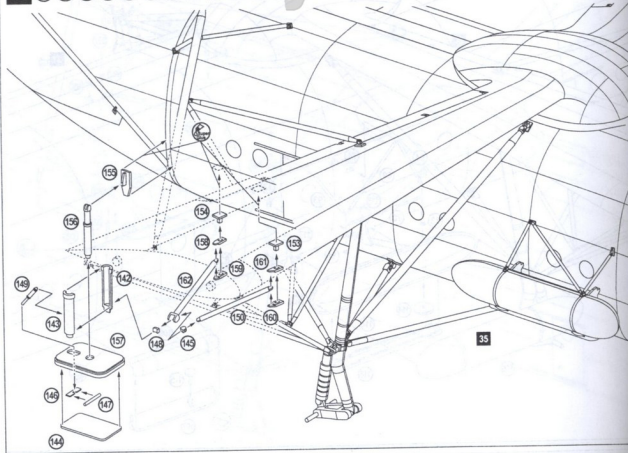
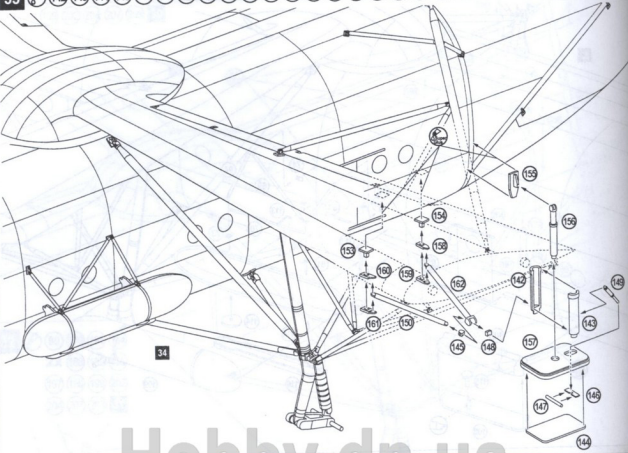

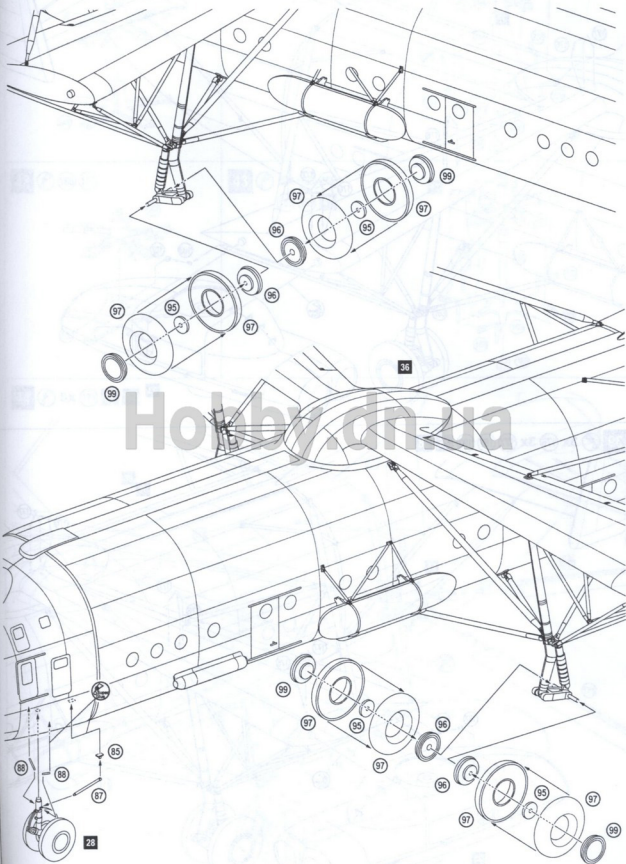

38 3x 176 3x 177 187 193 23 37

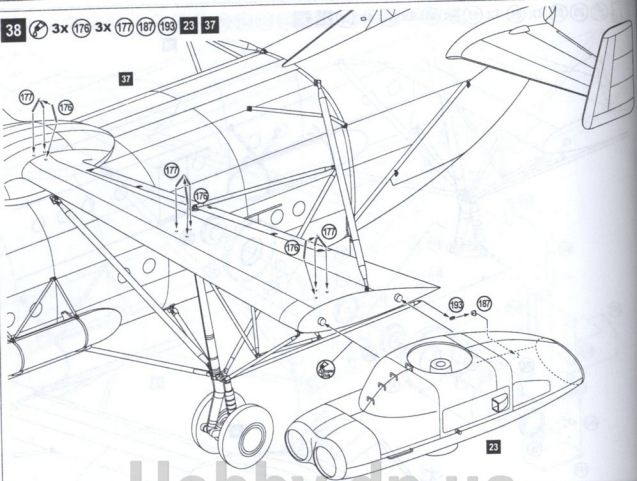

39 3x 176 3x 177 187 193 25 38

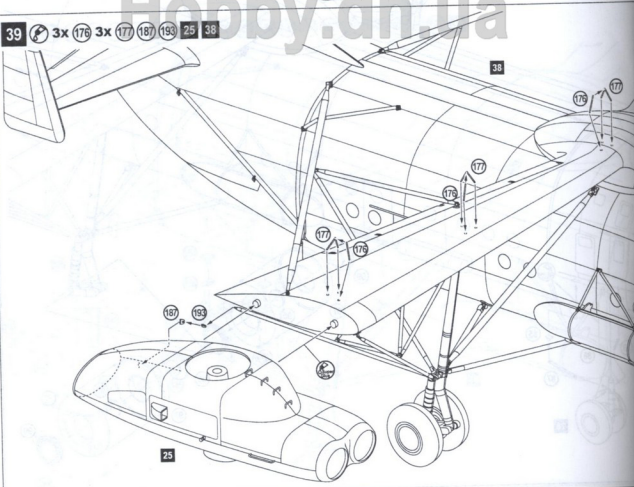

40  240 241

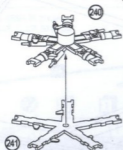

41  237 5x 238
243 244 40

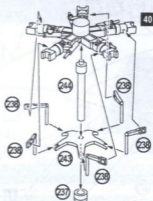

42  166 167

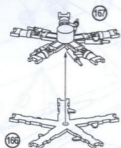

43  5x 163 165
168 169 42

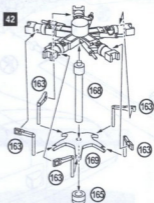

44  5x 171 39 43

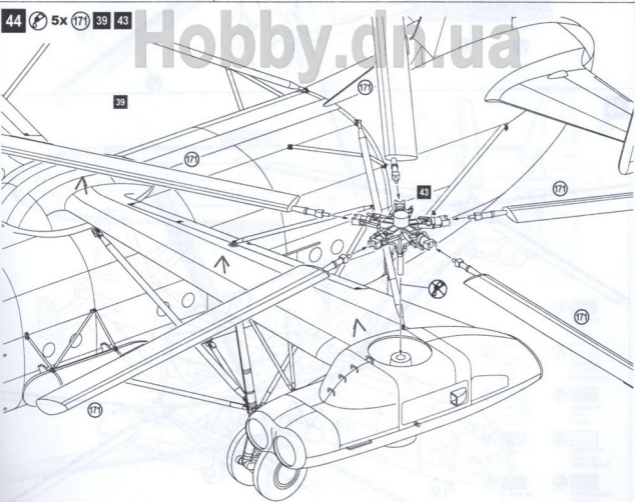

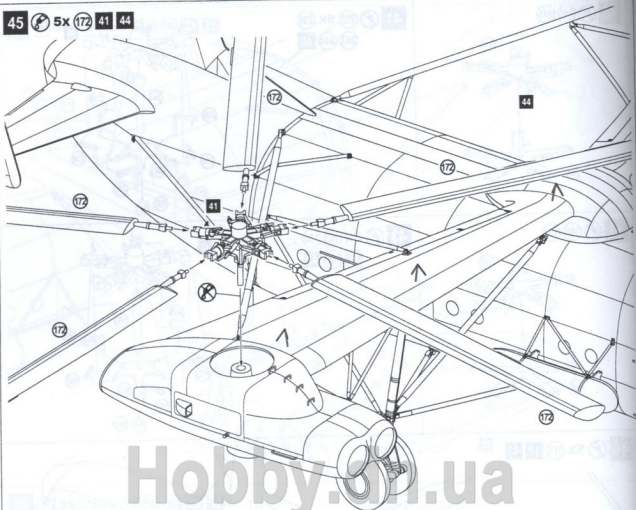

Hobby.com.ua

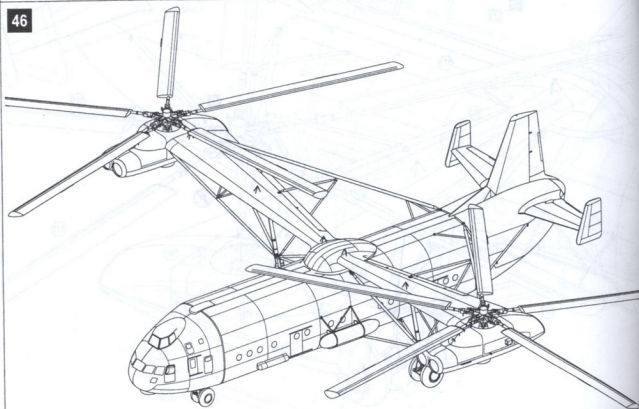

Ми М-12 (V-12), USSR, 60-th years
 Миль Ми-12 (B-12), СССР, 60-е года

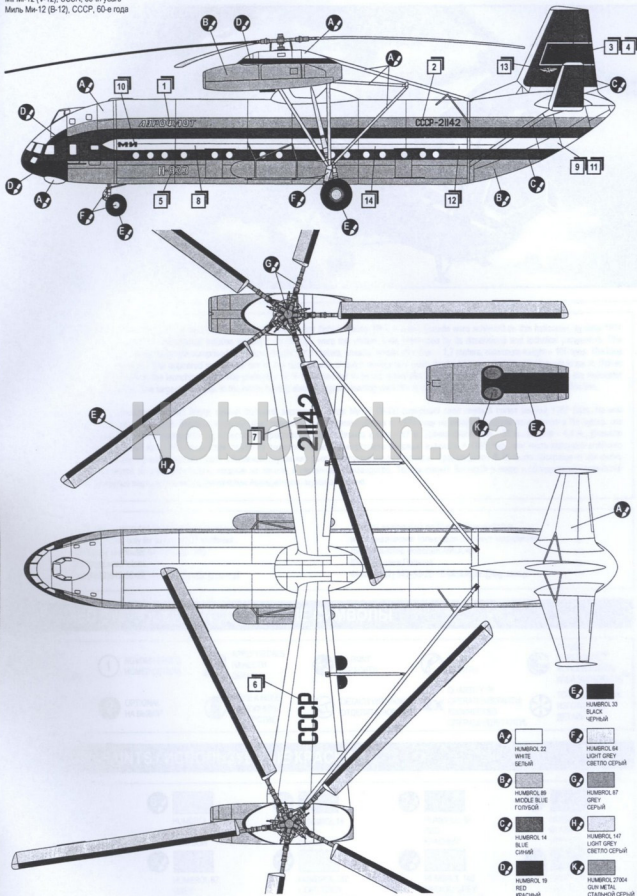

		HUMBROL 22 WHITE БЕЛЫЙ			HUMBROL 33 BLACK ЧЕРНЫЙ
		HUMBROL 89 MIDDLE BLUE СРЕДНИЙ			HUMBROL 66 LIGHT GREY СВЕТЛО СЕРЫЙ
		HUMBROL 14 BLUE СИНИЙ			HUMBROL 67 GREY СЕРЫЙ
		HUMBROL 19 RED КРАСНЫЙ			HUMBROL 147 LIGHT GREY СВЕТЛО СЕРЫЙ
					HUMBROL 2704 GLY METAL СТАЛЬНОЙ СЕРЫЙ