

PLASTIC MODEL KITS
LIMITED EDITION
CAT.NO.72033



SPAN : 704 mm
LENGTH : 660 mm
PARTS : 524 pieces
SCALE:1/72



Military-transport aircraft IL-76 was built in Iliushin Experimental Design Bureau in 1971. The chief designer of the aircraft is R.P. Papkovsky. In 1974 IL-76 went through the series of tests and was adopted for armament. On the basis of military-transport aircraft a lot of various aircraft of special use are built. Several planes were re-equipped into air command units IL-82, the flying hospital IL-76MD "Scalpel-MT" was built. In 1983 for testing the fighting laser and for studying the distribution of rays in the upper layer of the atmosphere, the version A-60 was built. On the basis of IL-76, the fuellers IL-78 and IL-78M were built and well as the aircraft of radio supervision A-50. In total around 950 aircraft IL-76 of all modifications were built, over 100 of which were sent for export.









Военно-транспортный самолет Ил-76 был построен в ОКБ Ильюшина в 1971 году. Главный конструктор самолета Р.П. Папковский. В 1974 году Ил-76 прошел весь комплекс испытаний и был принят на вооружение. На базе военно-транспортного самолета построено множество различных самолетов специального назначения. Так несколько самолетов было переоборудовано в воздушные командные пункты Ил-82, был построен летающий госпиталь Ил-76МД "Скальпель-МТ". В 1983 для отработки боевого лазера и для исследования распространения лучей в верхних слоях атмосферы был построен вариант А-60. На базе Ил-76 созданы самолеты заправки Ил-78 (Ил-78М), а также самолет радиолокационного дозора А-50. Всего выпущено около 950 самолетов Ил-76 всех модификаций, более 100 из которых поставлено на экспорт.

The model is executed on technology short run and is intended only for experienced modelers
Word-wide distributor for AMODEL kits: IBG, Warszawa, Poland
Fax: (4822) 842-56-29; E-Mail: ibgsc@ibg.com.pl

Модель выполнена по технологии short run и предназначена только для опытных моделистов
Дистрибьютор моделей AMODEL: IBG, Варшава, Польша
Факс: (4822) 842-56-29; E-Mail: ibgsc@ibg.com.pl





USED SYMBOLS / ИСПОЛЬЗУЕМЫЕ СИМВОЛЫ

- | | | | | | |
|---|---------------------------------------|--|---|---|---|
| 1 STAGES OF ASSEMBLY
ЭТАПЫ СБОРКИ | 1 NUMBER PARTS
НОМЕР ДЕТАЛИ | 1 APPLY DECALS
НАНЕСИ ДЕКАЛЬ | A TO PAINT
ОКРАСИТЬ |  GLUE
КЛЕИТЬ |  TO USE SUPERGLUE™
ИСПОЛЬЗОВАТЬ КЛЕЙ SUPERGLUE™ |
|  DON'T GLUE
НЕ КЛЕИТЬ | ? OPTIONAL
НА ВЫБОР |  MAKE A HOLE
ВЫПОЛНИТЬ ОТВЕРСТИЕ |  DETACH WITH KNIFE
ОТДЕЛИТЬ НОЖОМ | 2x QUANTITY OF OPERATIONS(PARTS)
КОЛИЧЕСТВО ОПЕРАЦИЙ(ДЕТАЛЕЙ) |  TO MAKE A DETAIL
ИЗГОТОВИТЬ ДЕТАЛЬ |



USED PAINTS / ИСПОЛЬЗУЕМЫЕ КРАСКИ

- | | | | | |
|---|---|---|--|--|
| A  HUMBROL 27
SEA GREY
СЕРО-ГОЛУБОЙ | B  HUMBROL 145
MEDIUM GREY
СРЕДНЕ-СЕРЫЙ | C  HUMBROL 27002
POLISHED ALUMINIUM
ПОЛИР. АЛЮМИНИЙ | D  HUMBROL 19
RED
КРАСНЫЙ | E  HUMBROL 33
BLACK
ЧЕРНЫЙ |
| F  HUMBROL 34
WHITE
БЕЛЫЙ | G  HUMBROL 64
LIGHT GREY
СВЕТЛО СЕРЫЙ | H  HUMBROL 101
MID GREEN
СРЕДНЕ ЗЕЛЕНый | K  HUMBROL 27004
GUN METAL
СТАЛЬНОЙ СЕРЫЙ | |

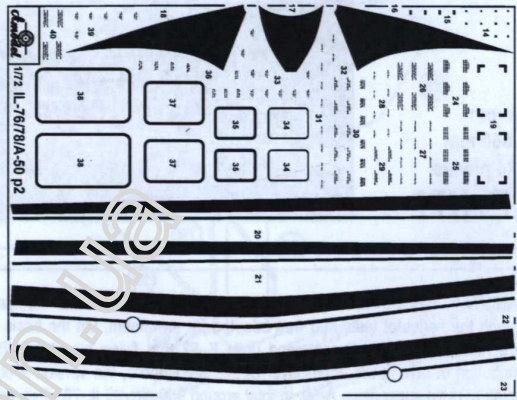
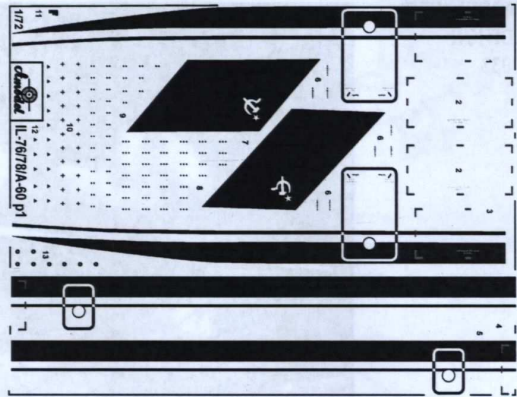
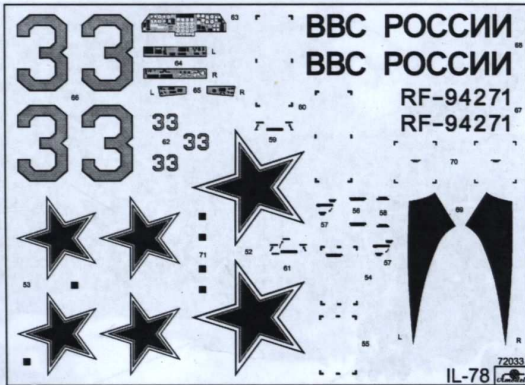

DECALS FOR TWO VERSIONS OF COLOURING
ДЕКАЛЬ ДЛЯ ДВУХ ВАРИАНТОВ ОКРАСКИ

524 DETAILS FOR ASSEMBLY OF ONE MODEL
524 ДЕТАЛИ ДЛЯ СБОРКИ ОДНОЙ МОДЕЛИ

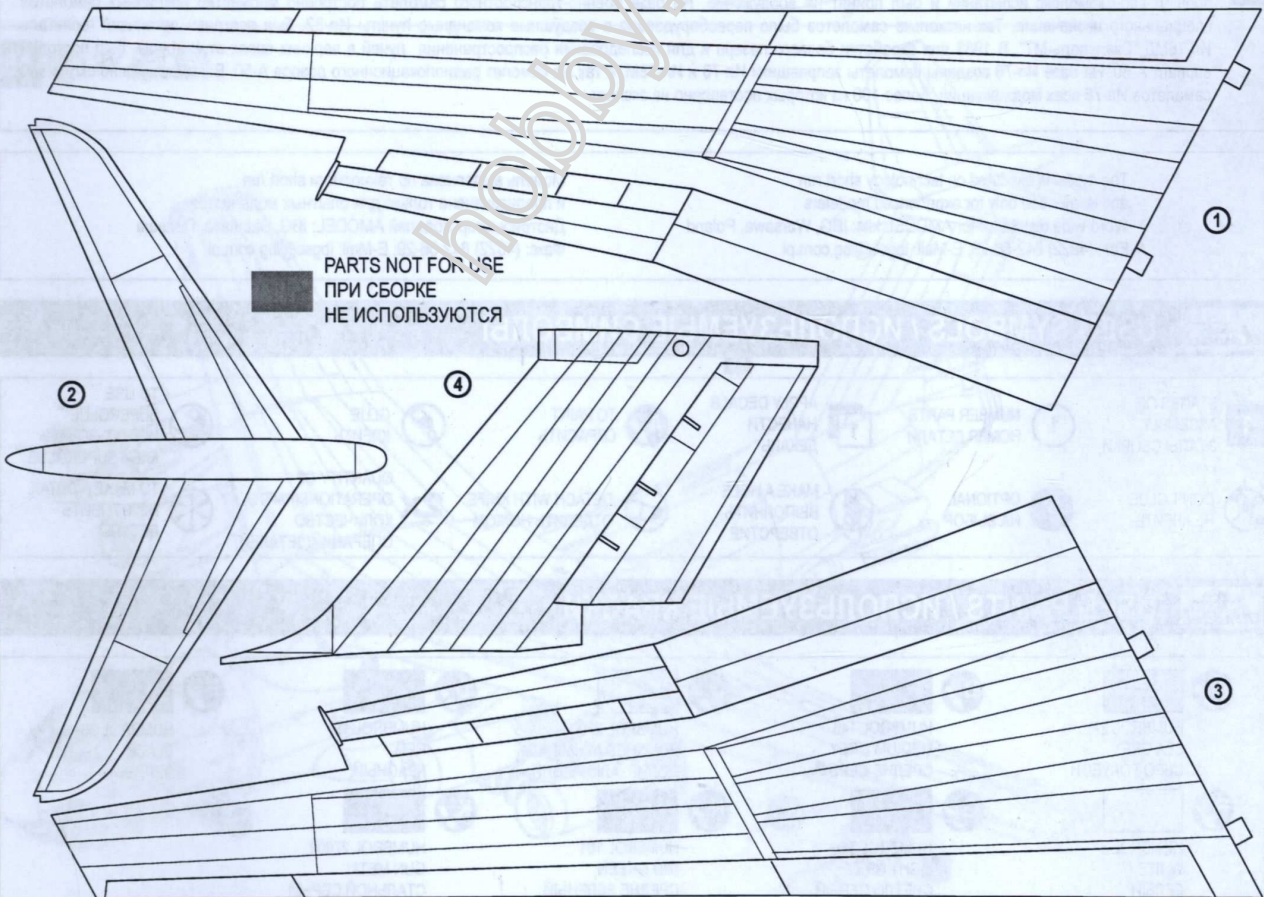

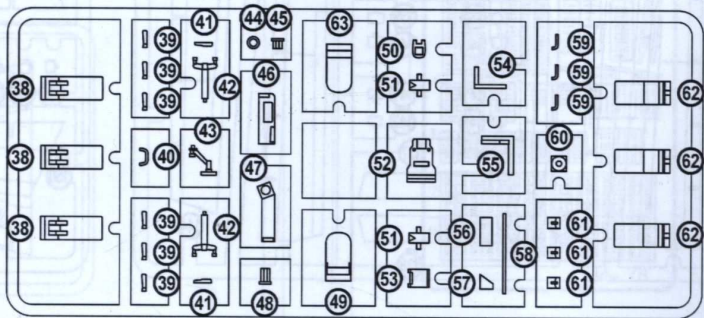
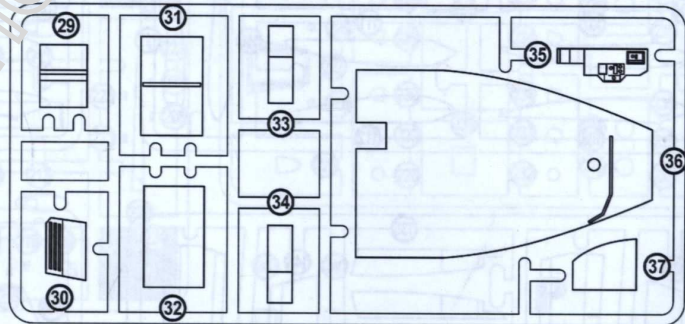
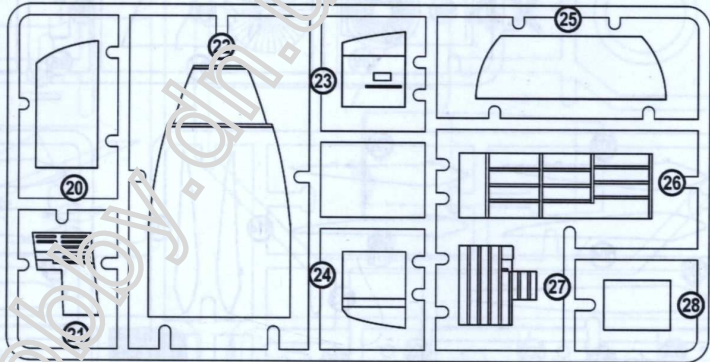
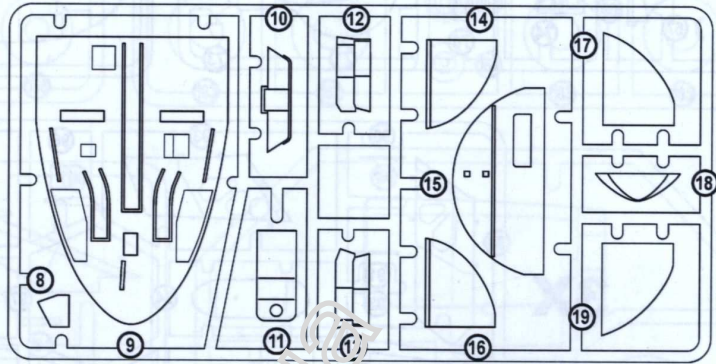
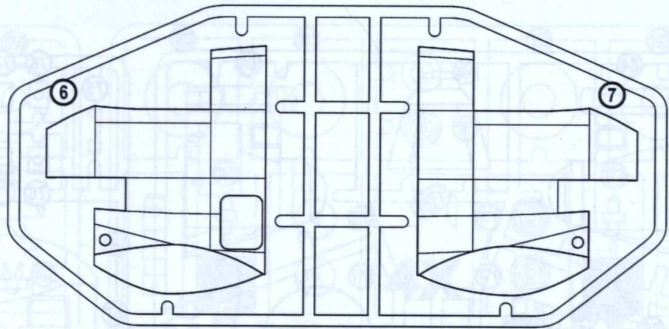
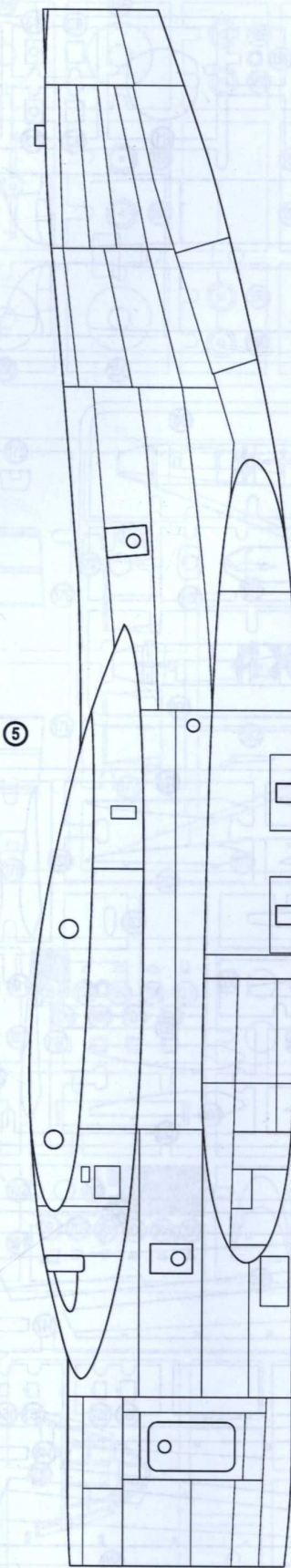

COMPLETE SET TO COMPLETE THE SET

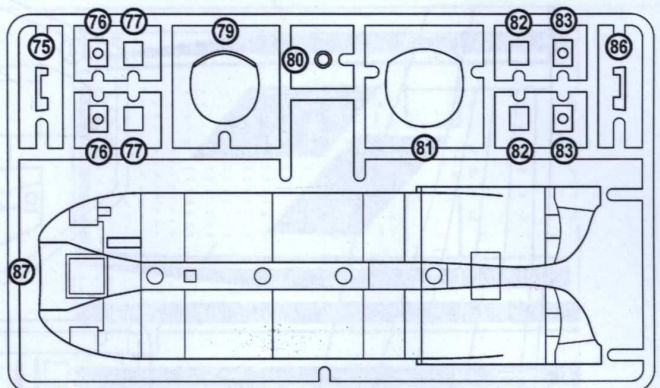
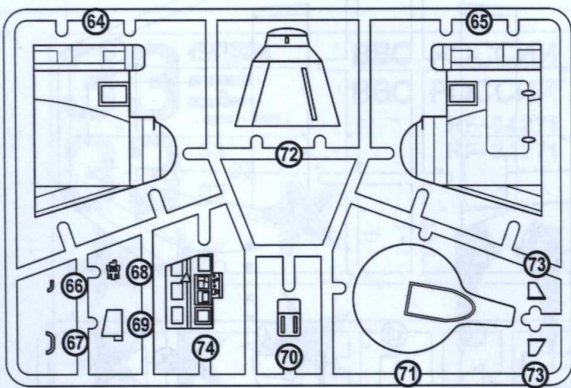

3X

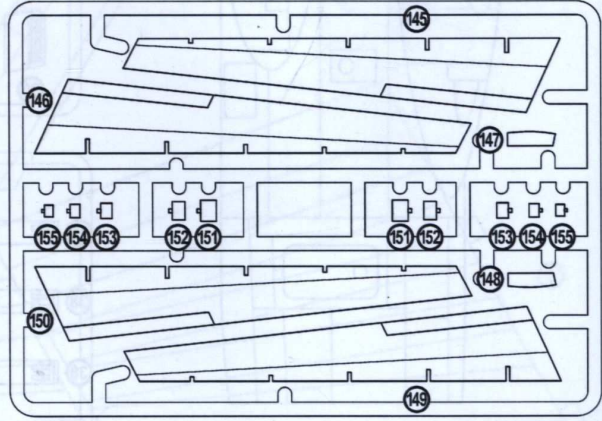
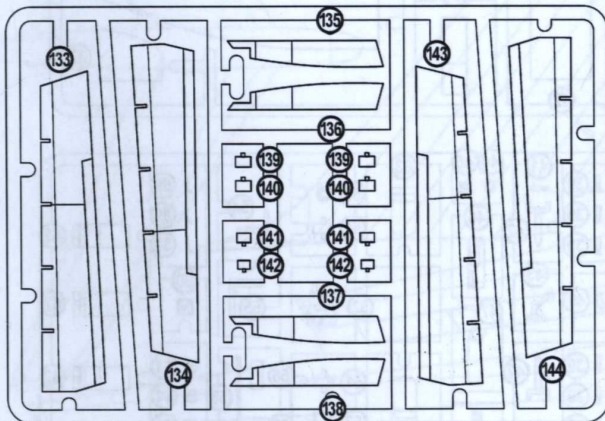
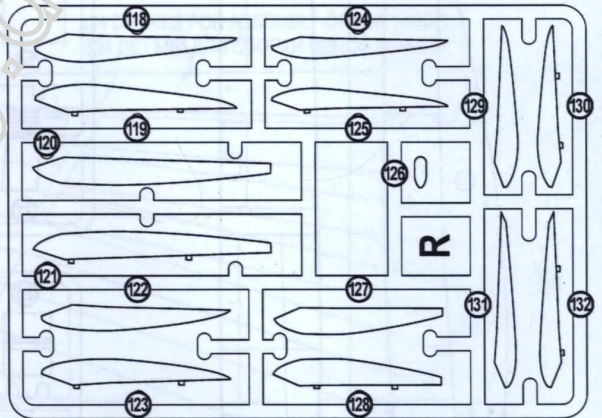
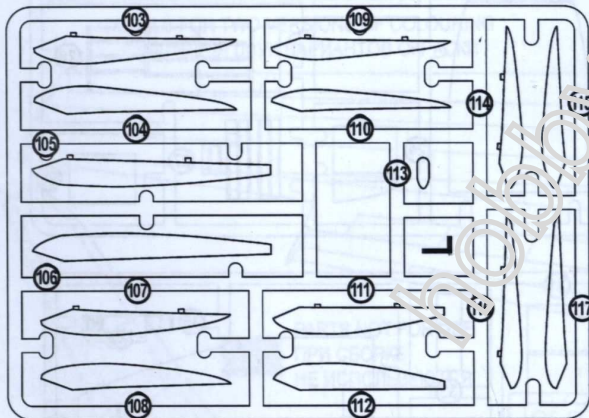
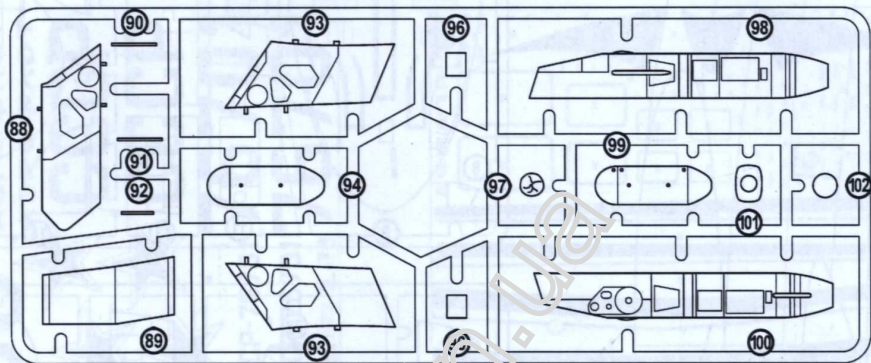

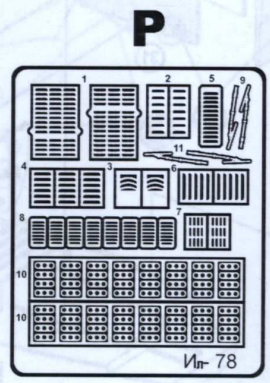
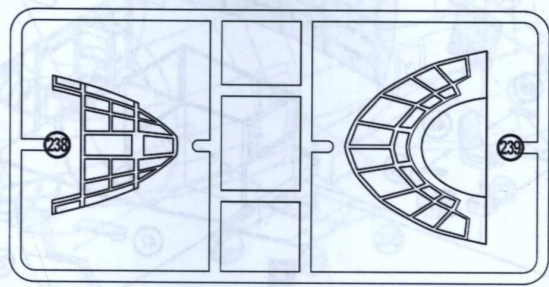
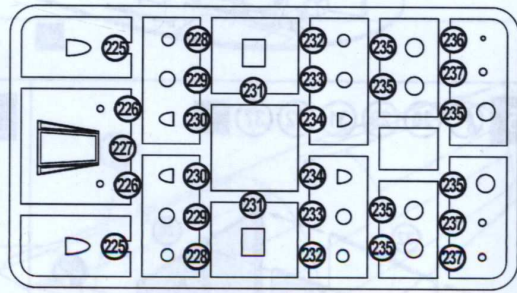
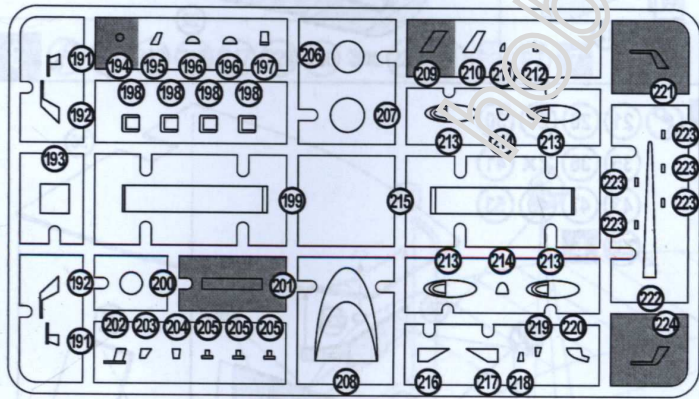
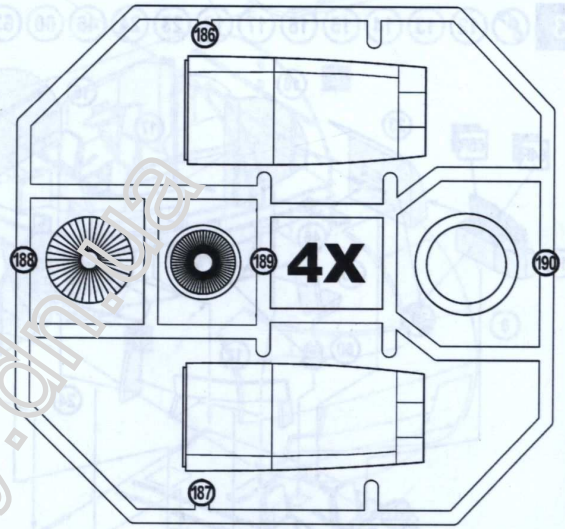
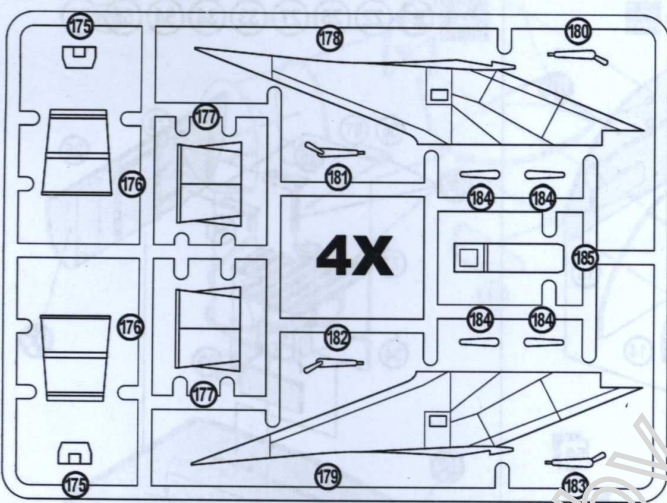
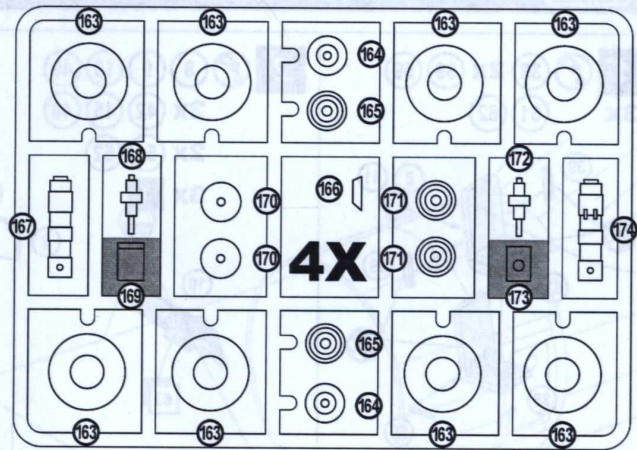
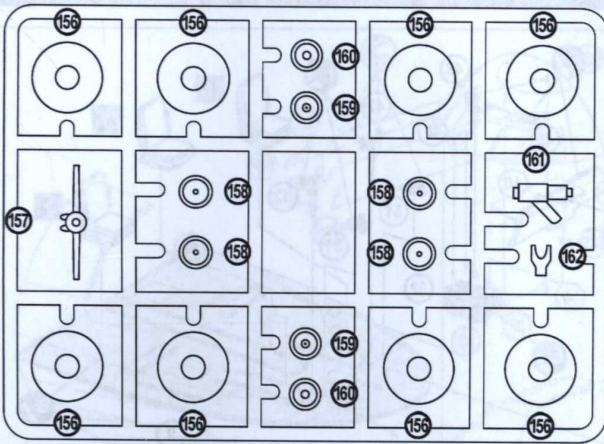

Ил. 78

- 1** 38 2x 39 59
3x 61 62

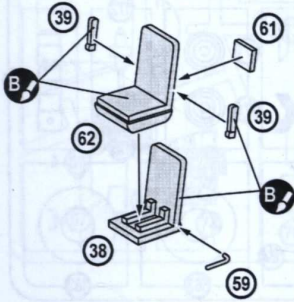

- 2** 8 9 10 40
2x 42 45 48
2x 51 52
3x 1

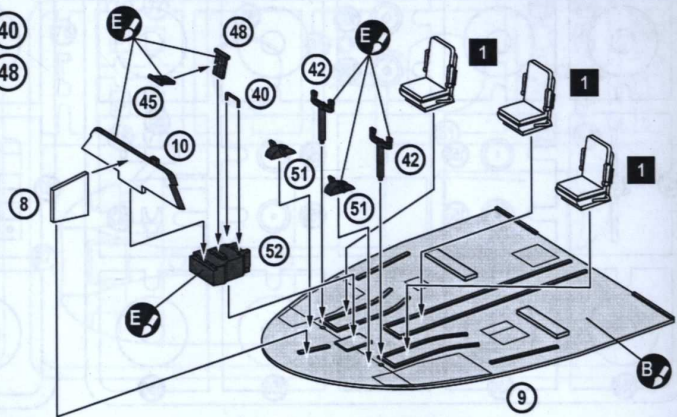

- 3** 12 13 14 15 16 17 19 23 24 46 60 63 2

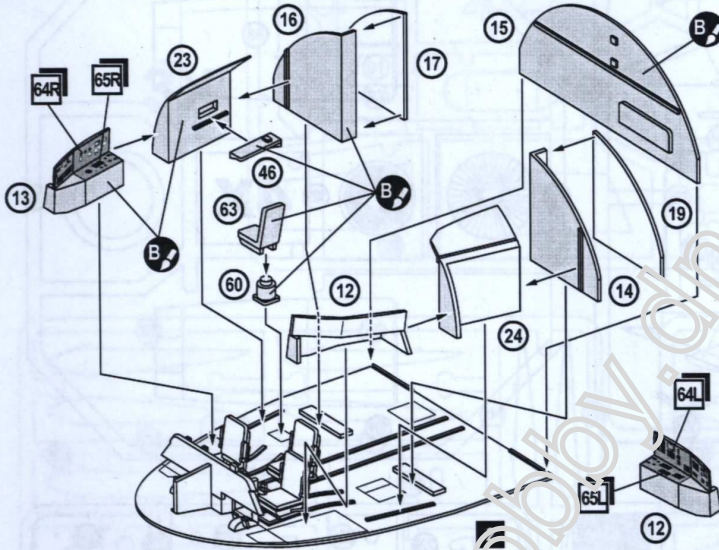

- 4** 22 25 27 33 34 54 55 56

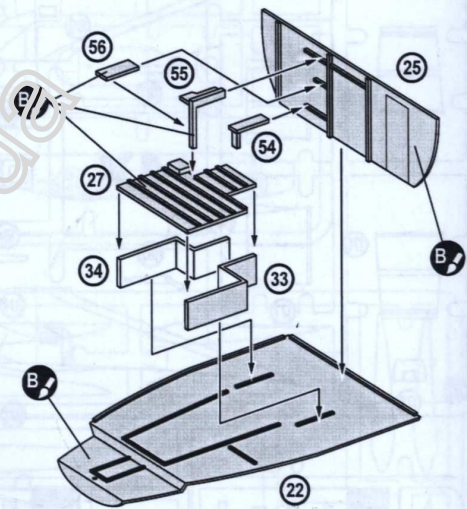

- 5** 20 29 31 32 37 4

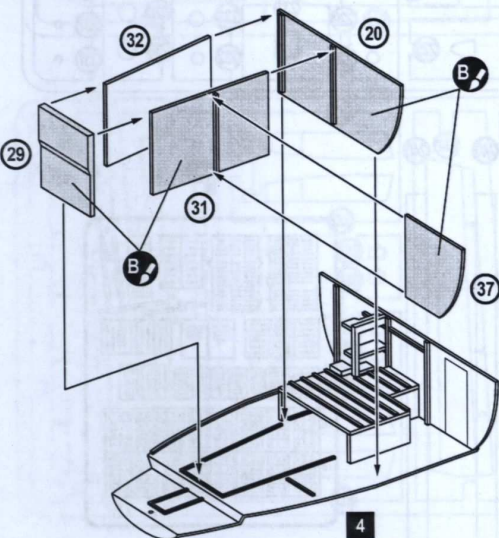

- 6** 21 26 28 30
35 36 2x 41
43 47 49 53
233 5

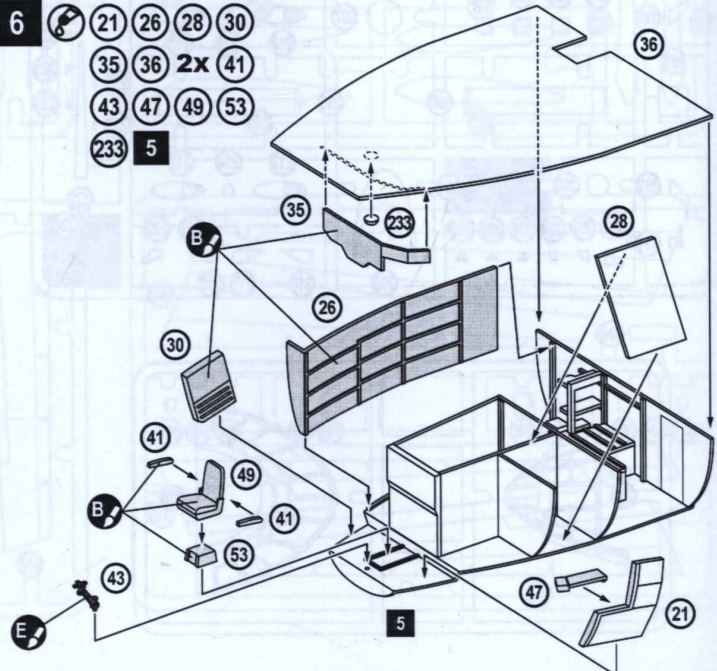

7 5 6 7 11 18 44 50 58 79 81 2x 228 233 238 239 2x P9 2x P11 3 6

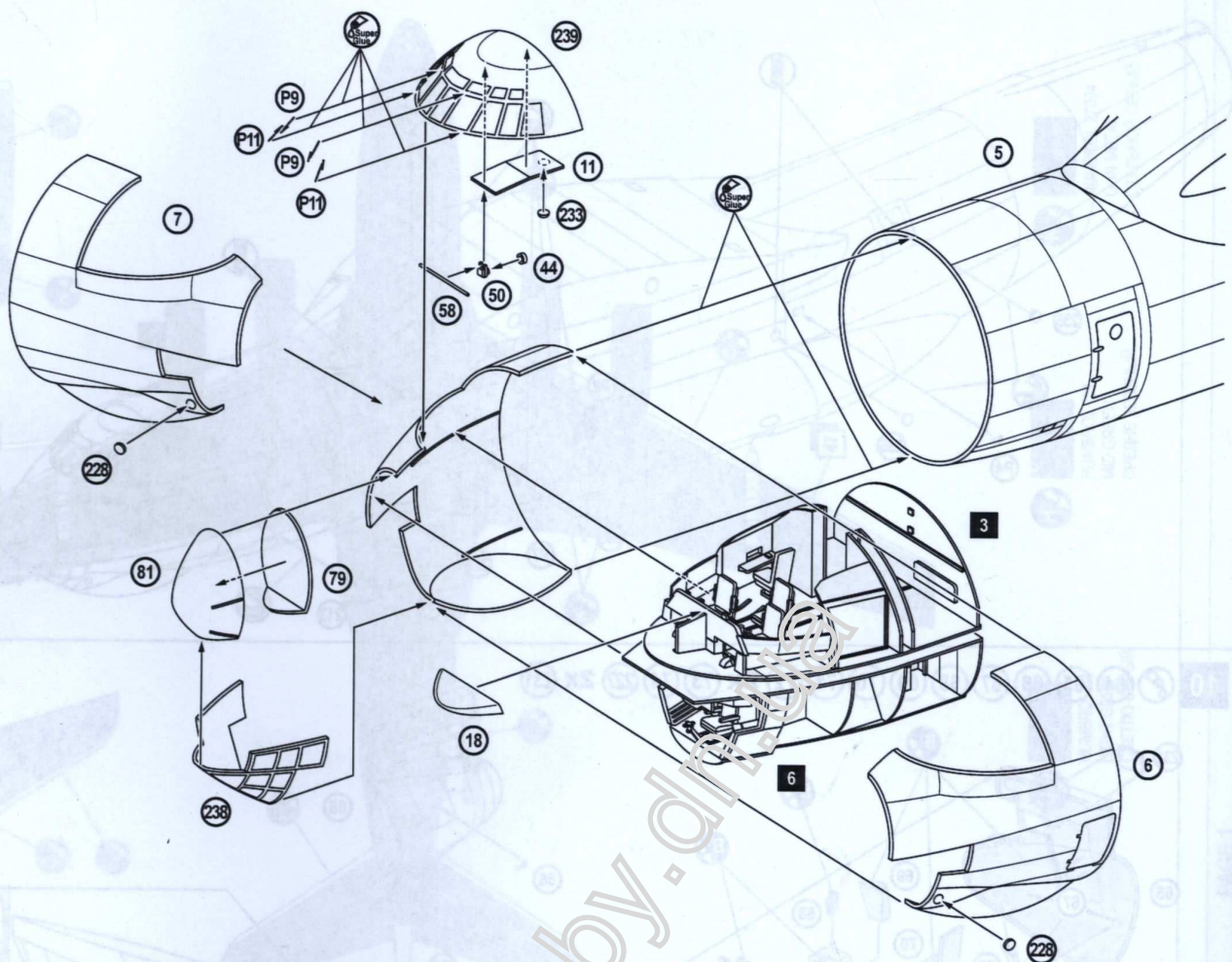

8 86 213 216 217 229 230 3x 235 P1 P2 P7 7

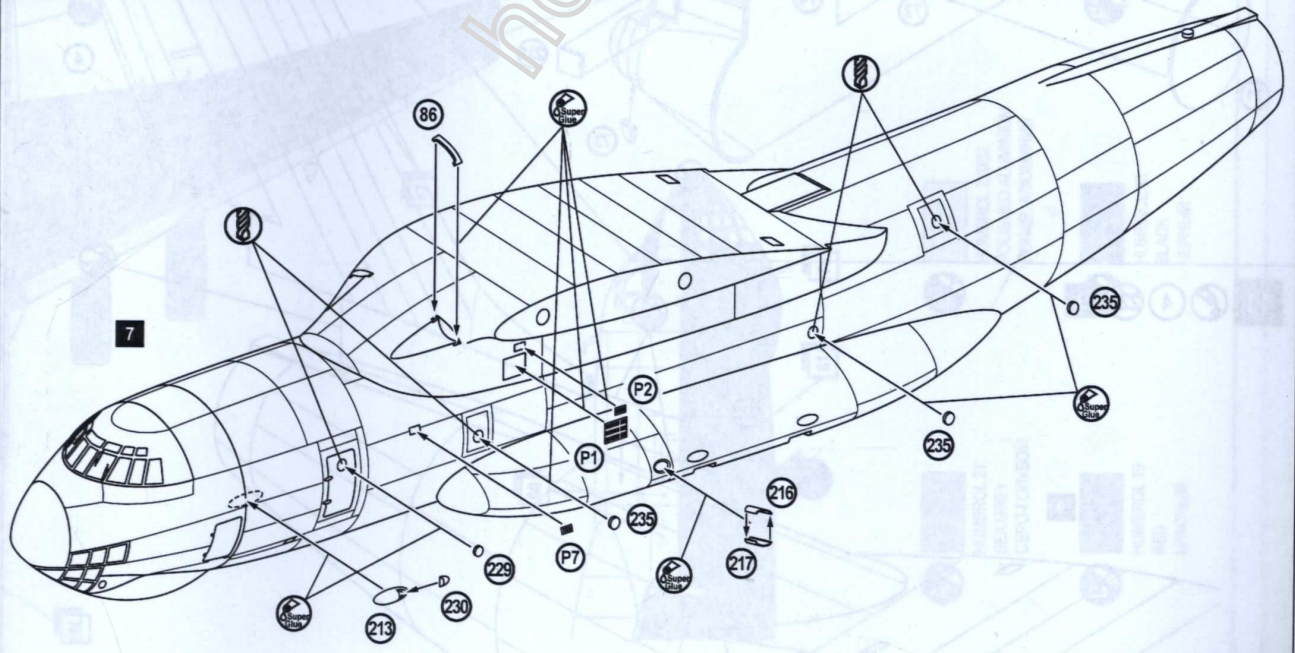

9 75 213 229 230 3x 235 P1 P2 P4 P7 8

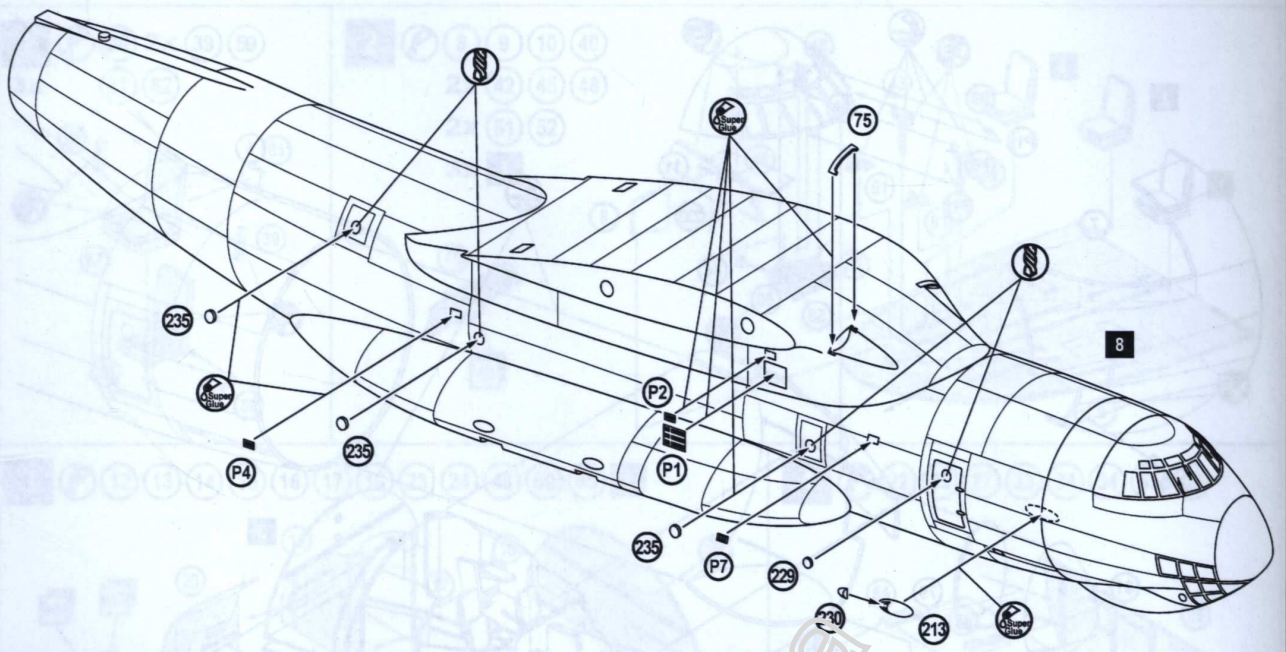

10 64 65 66 67 68 69 70 71 72 2x 73 74 227 2x 231

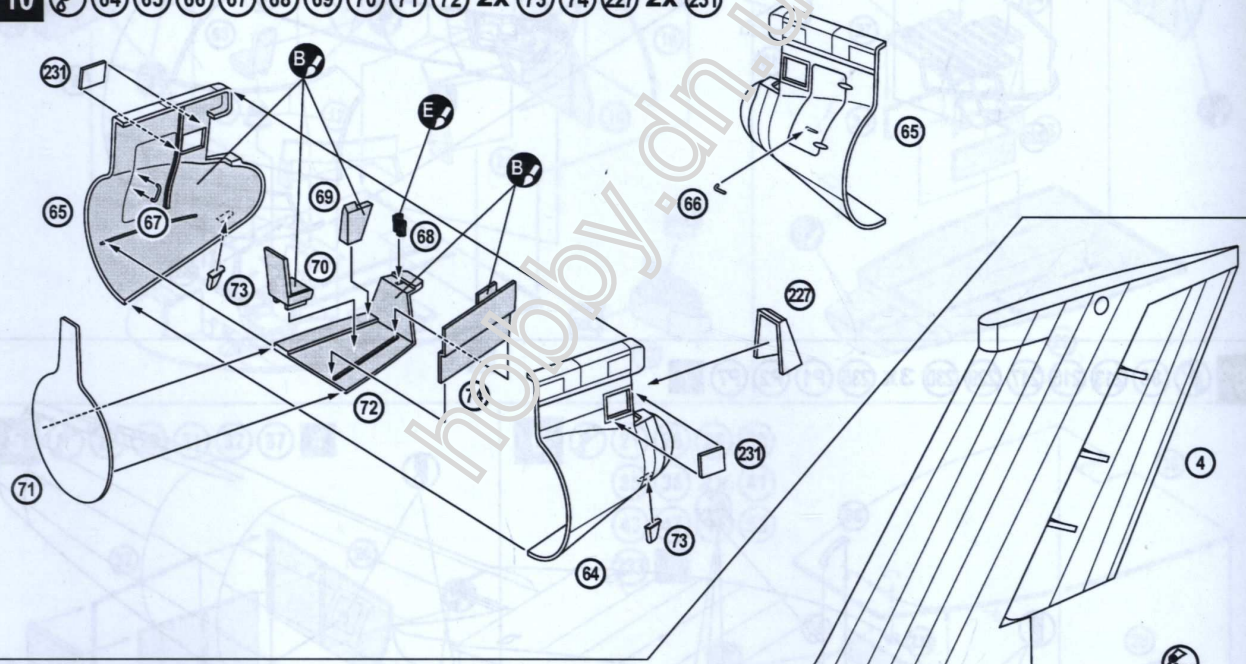

11 4 222 9

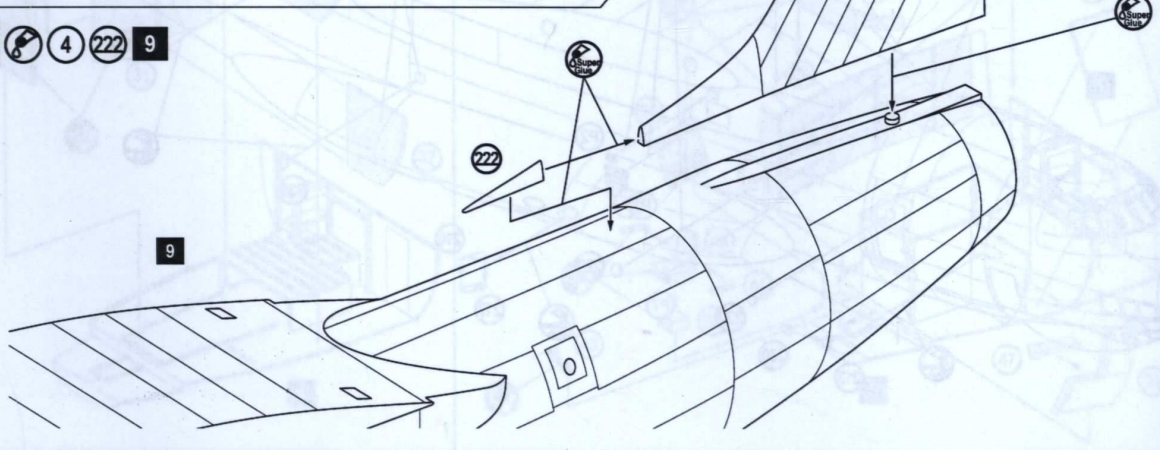

12  203 10 11

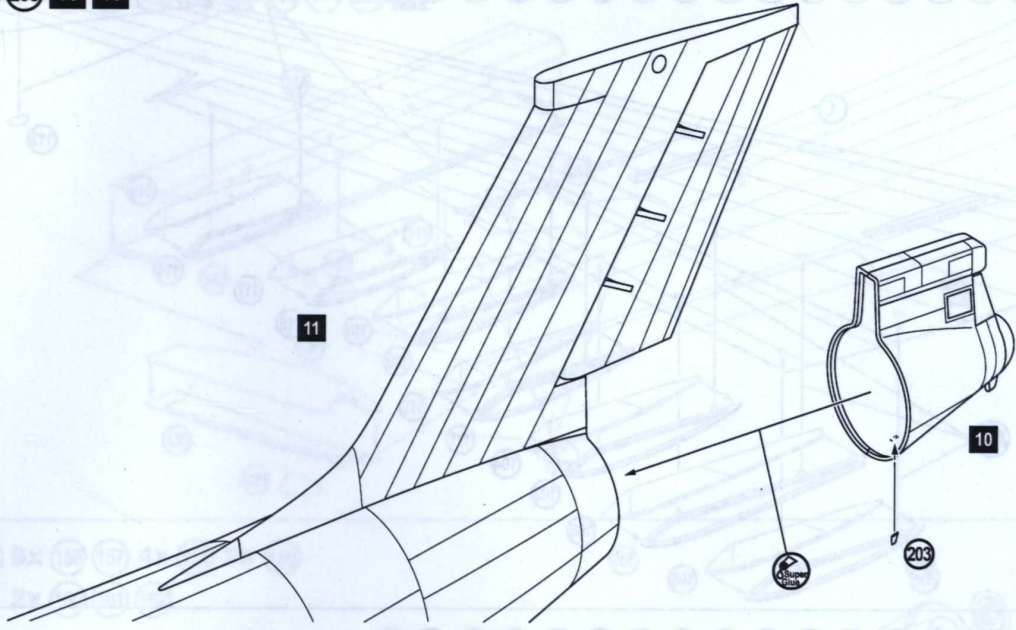

13  2 145 147 149 151 152 153 154 155

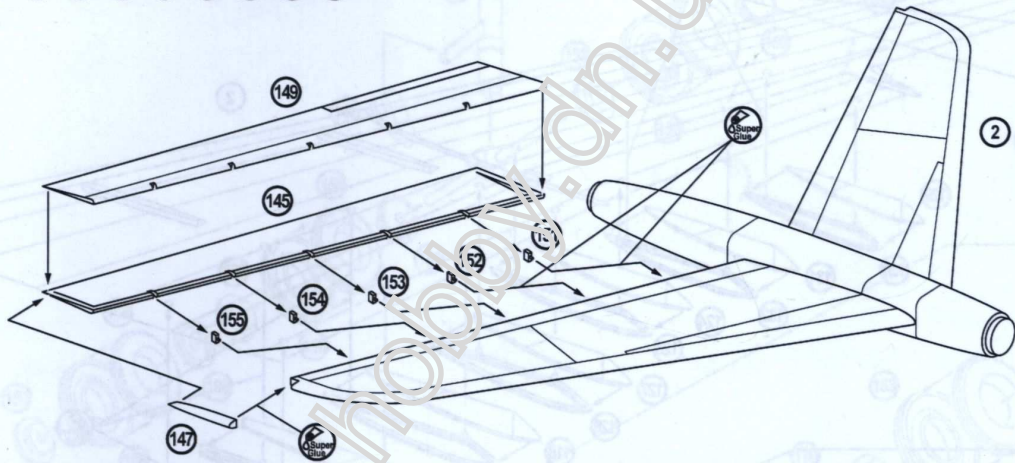

14  146 148 150 151 152 153 154 155 206 207 13

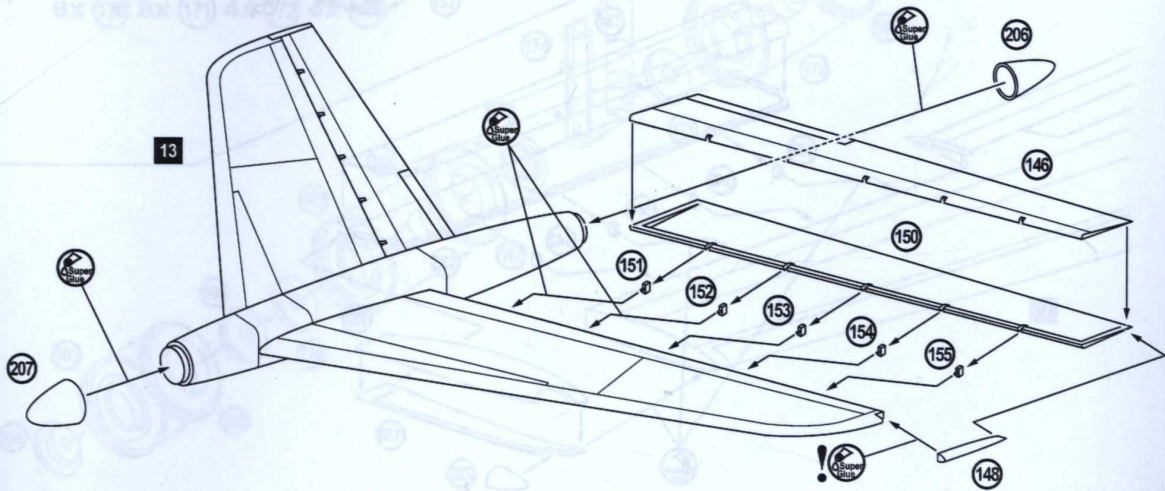

15 1 103 104 105 106 107 108 109 110 111 112 113 114 115 116 117 232

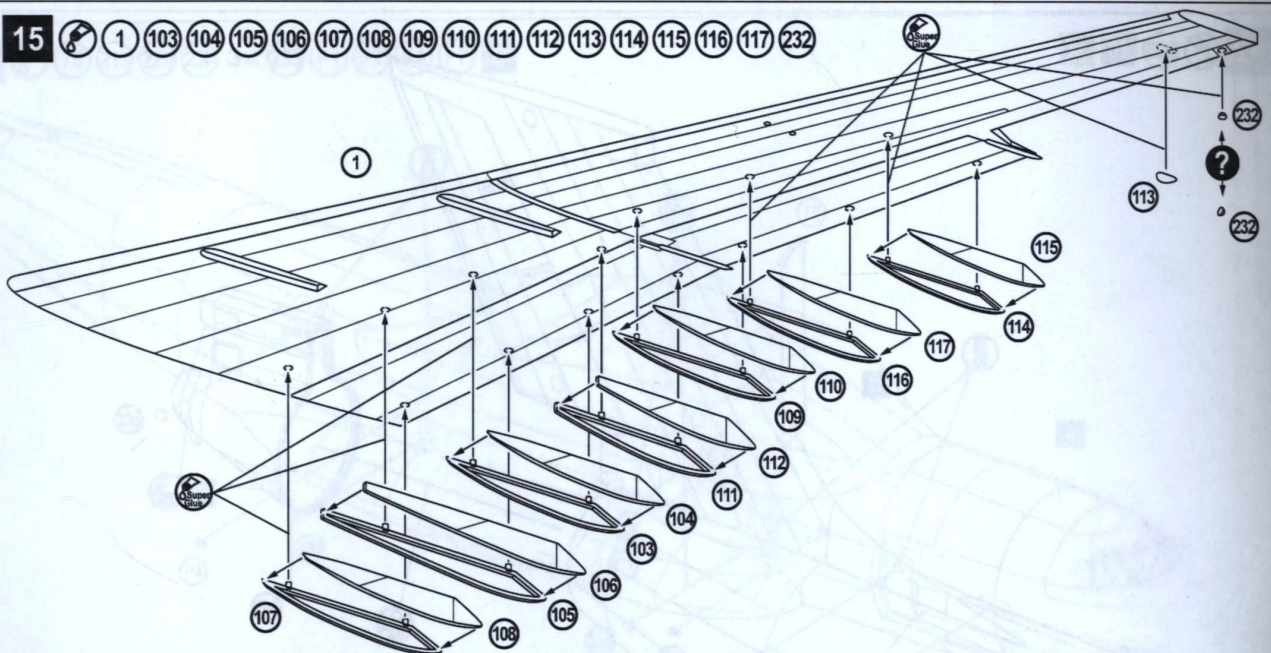

16 2 118 119 120 121 122 123 124 125 126 127 128 129 130 131 132 232

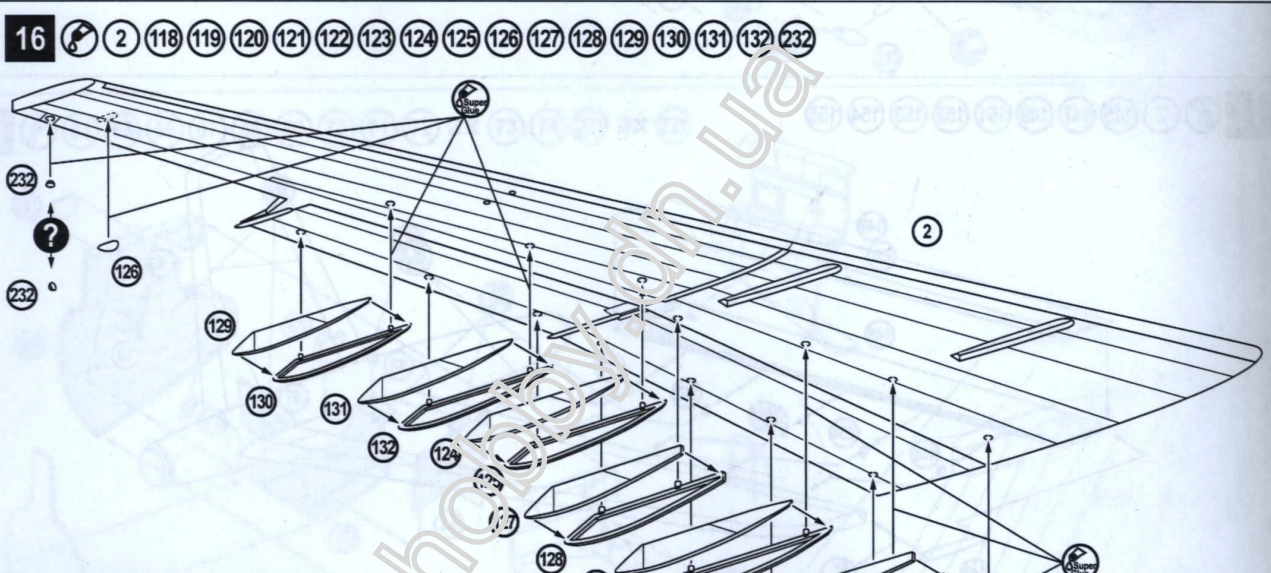

17 133 134 137 138 139
140 141 142 225 15

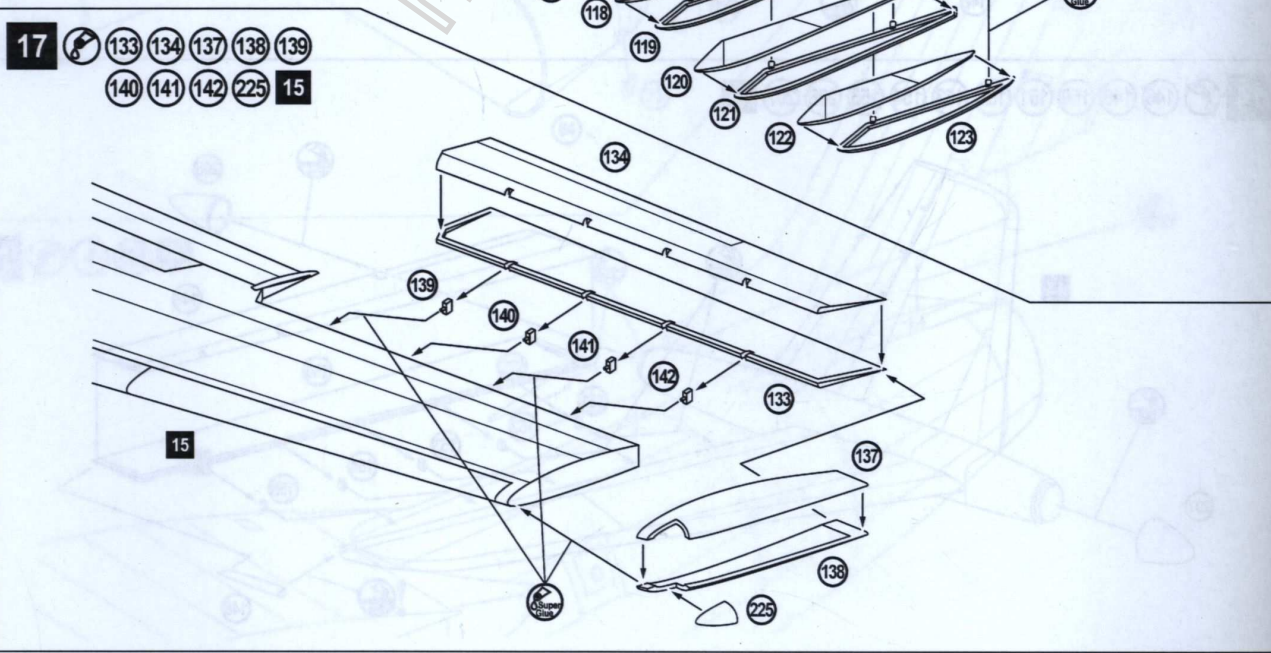

18 135 136 139 140 141 142 143 144 225 16

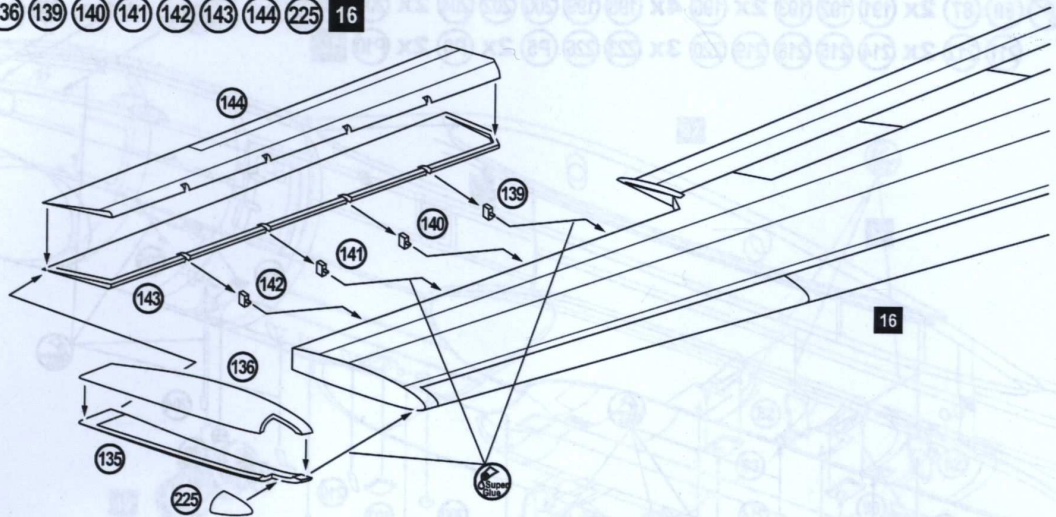

19 8x 156 157 4x 158 2x 159
2x 160 161 162

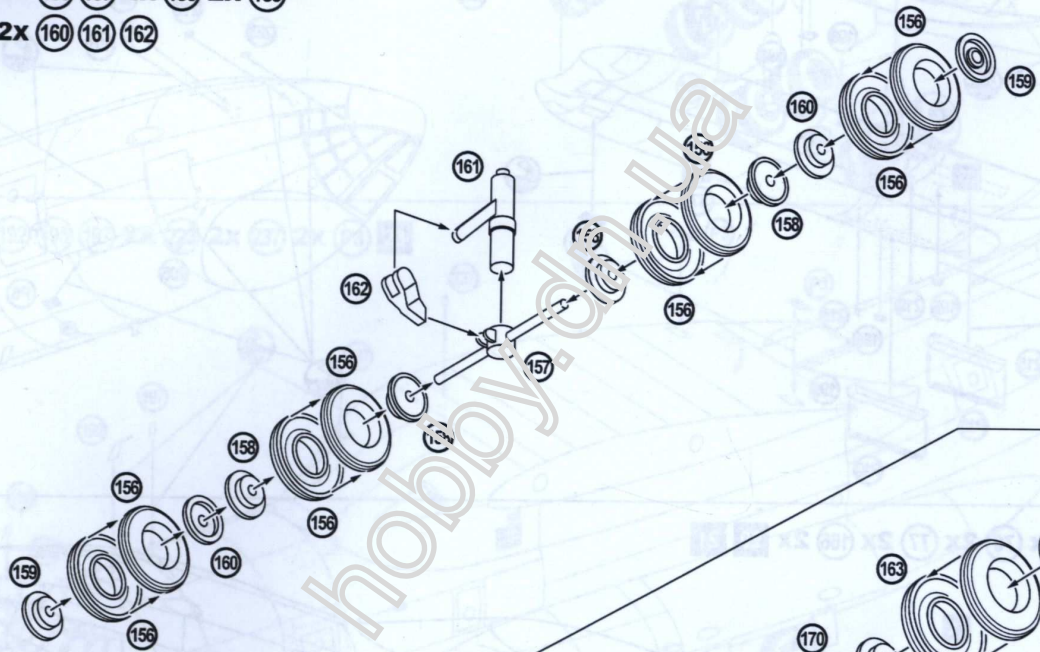

20 32x 163 8x 164 8x 165 4x 167 4x 168
4x 8x 170 8x 171 4x 172 4x 174

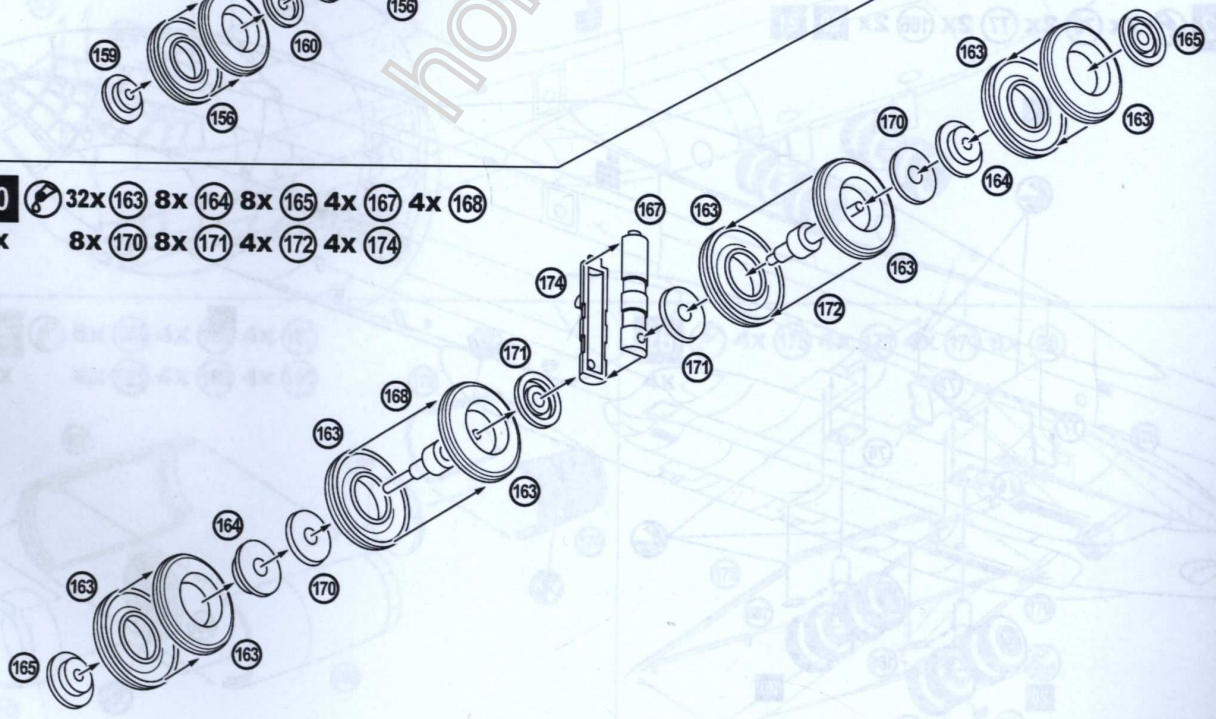

21 80 87 2x 191 192 193 2x 196 4x 198 199 200 202 204 2x 205 208 210
211 212 2x 214 215 218 219 220 3x 223 226 P5 2x P6 2x P10 12

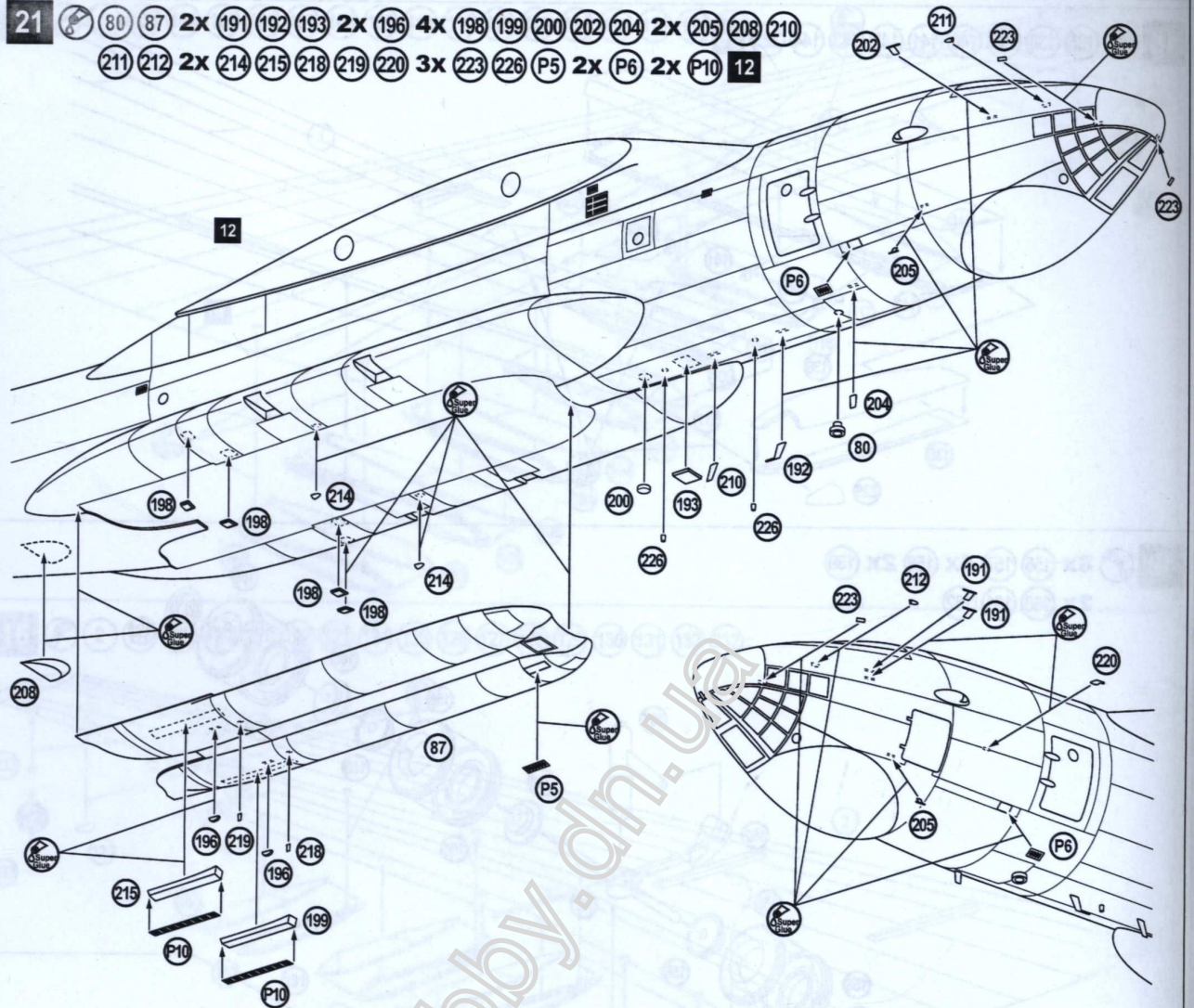

22 2x 76 2x 77 2x 166 2x 20 4

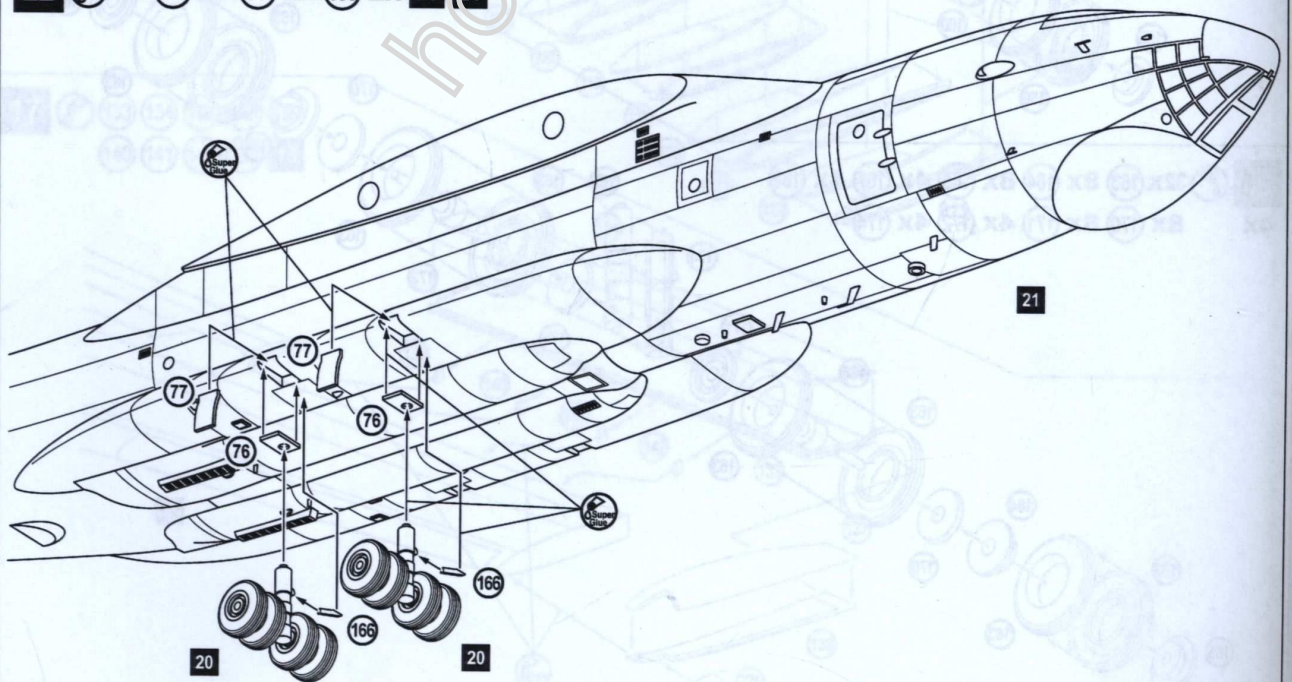

23 2x 82 2x 83 2x 166 19 2x 20 22

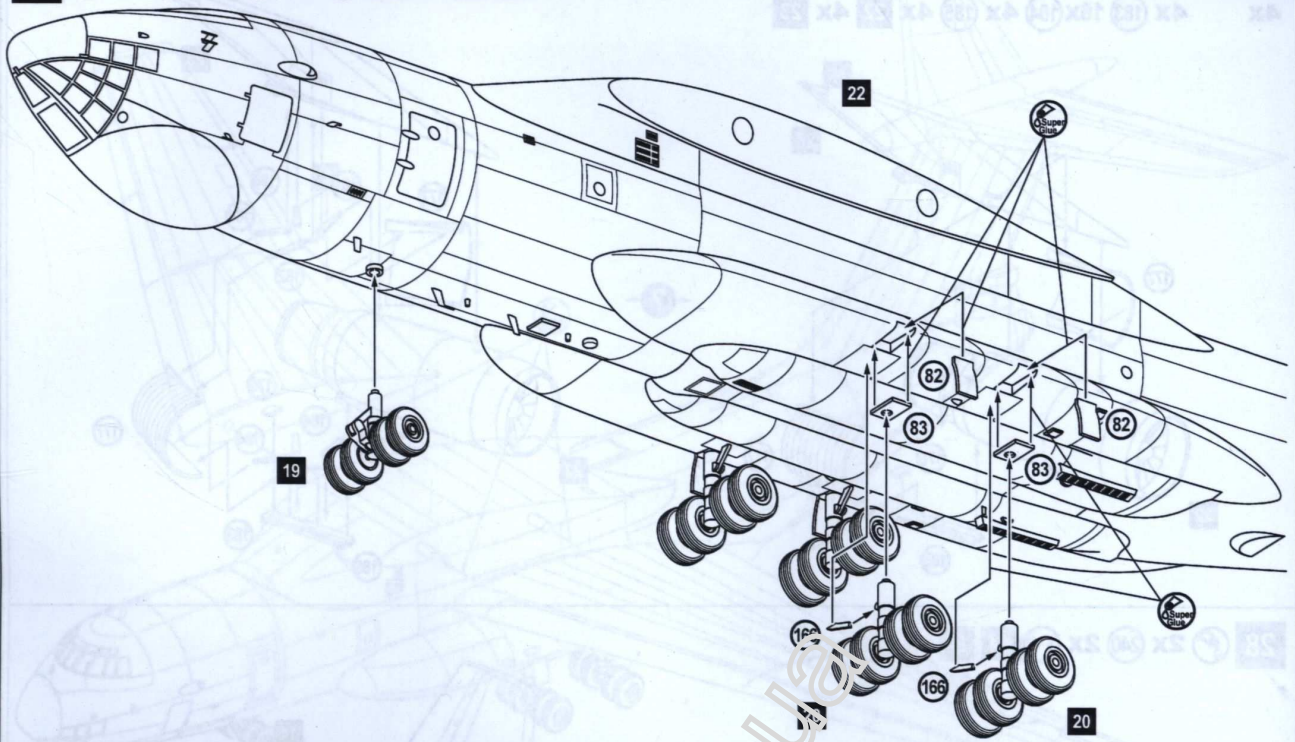

24 192 195 197 2x 223 2x 237 2x P3 23

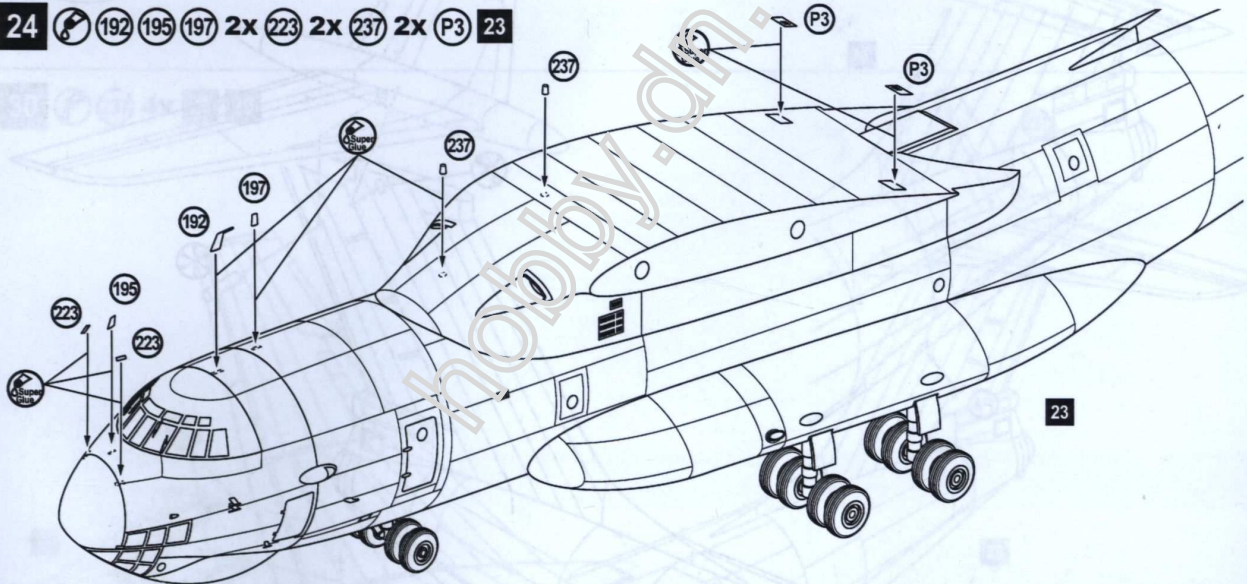

25 8x 176 4x 186 4x 187
4x 4x 188 4x 189 4x 190

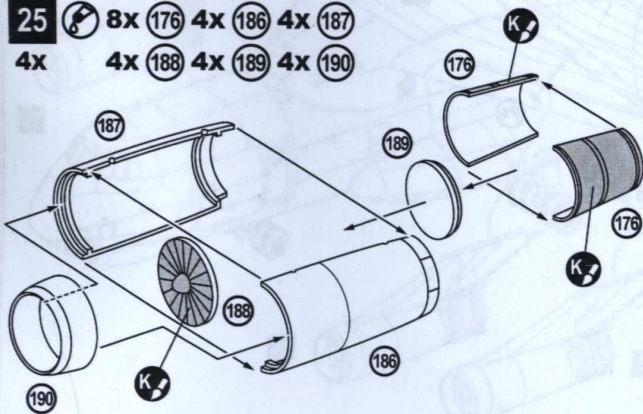

26 4x 175 4x 178 4x 179 8x P8
4x

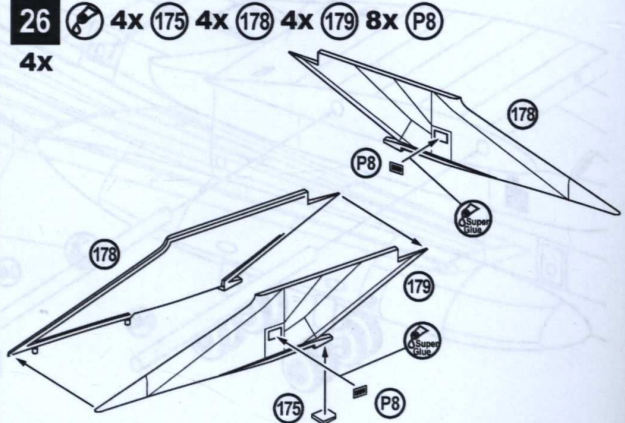

27 4x 175 8x 177 4x 180 4x 181 4x 182
 4x 183 4x 184 16x 184 4x 185 4x 22 4x 23

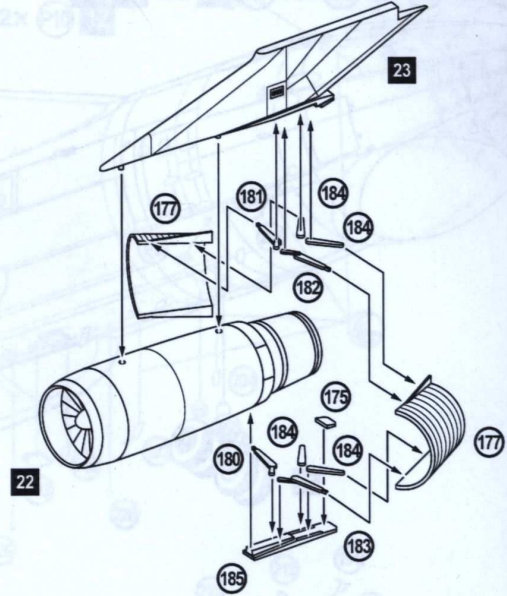
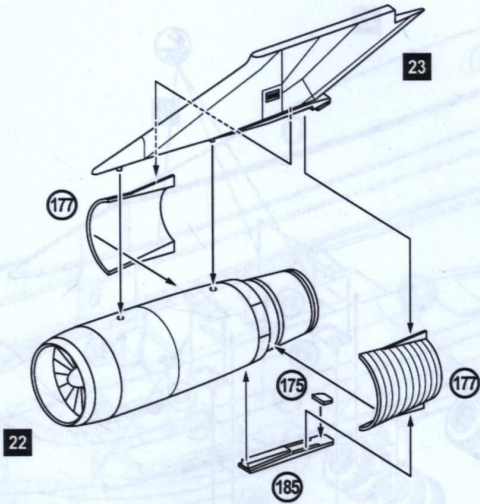

28 2x 240 2x P4 14 24

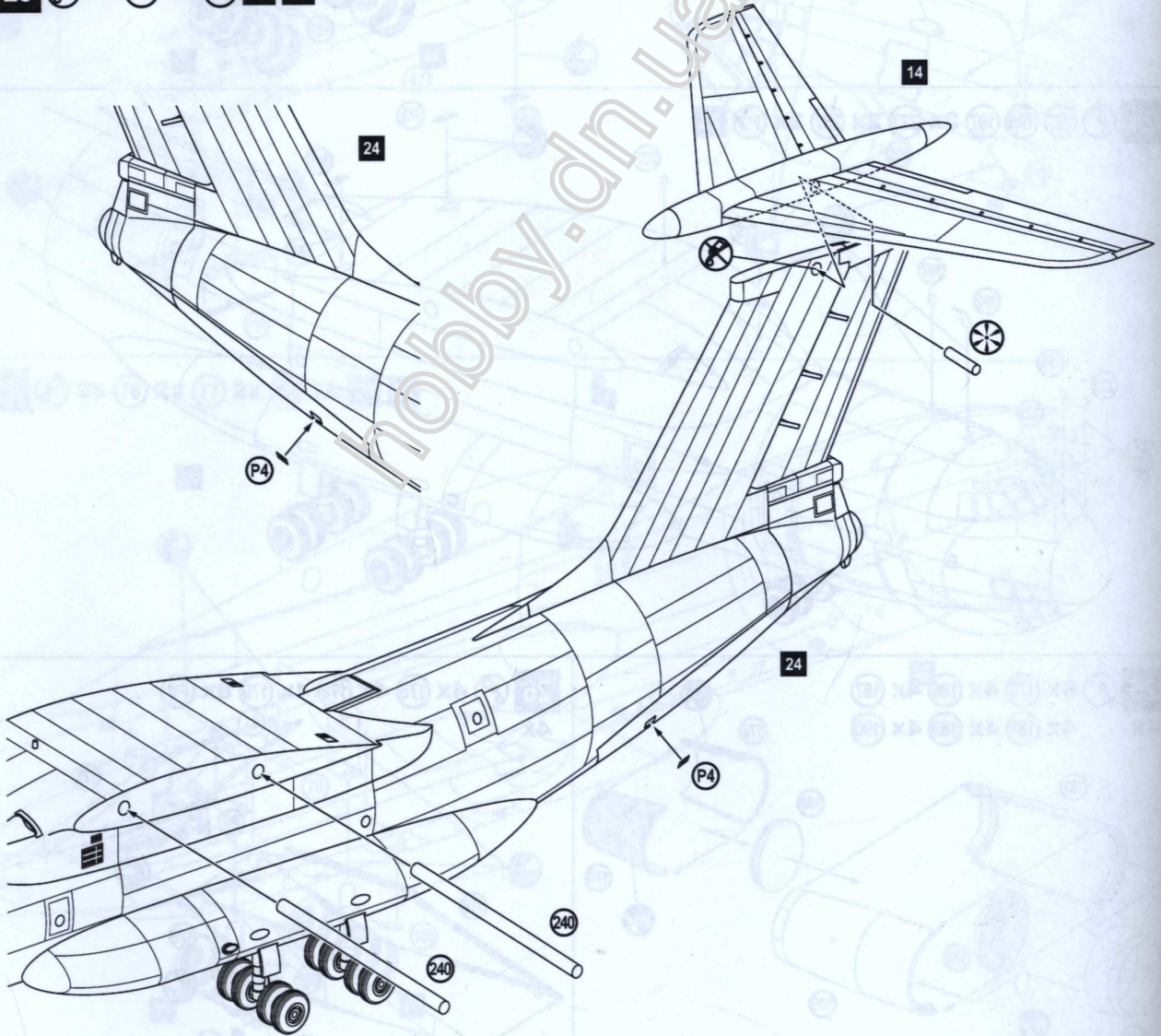

29  17 18 28

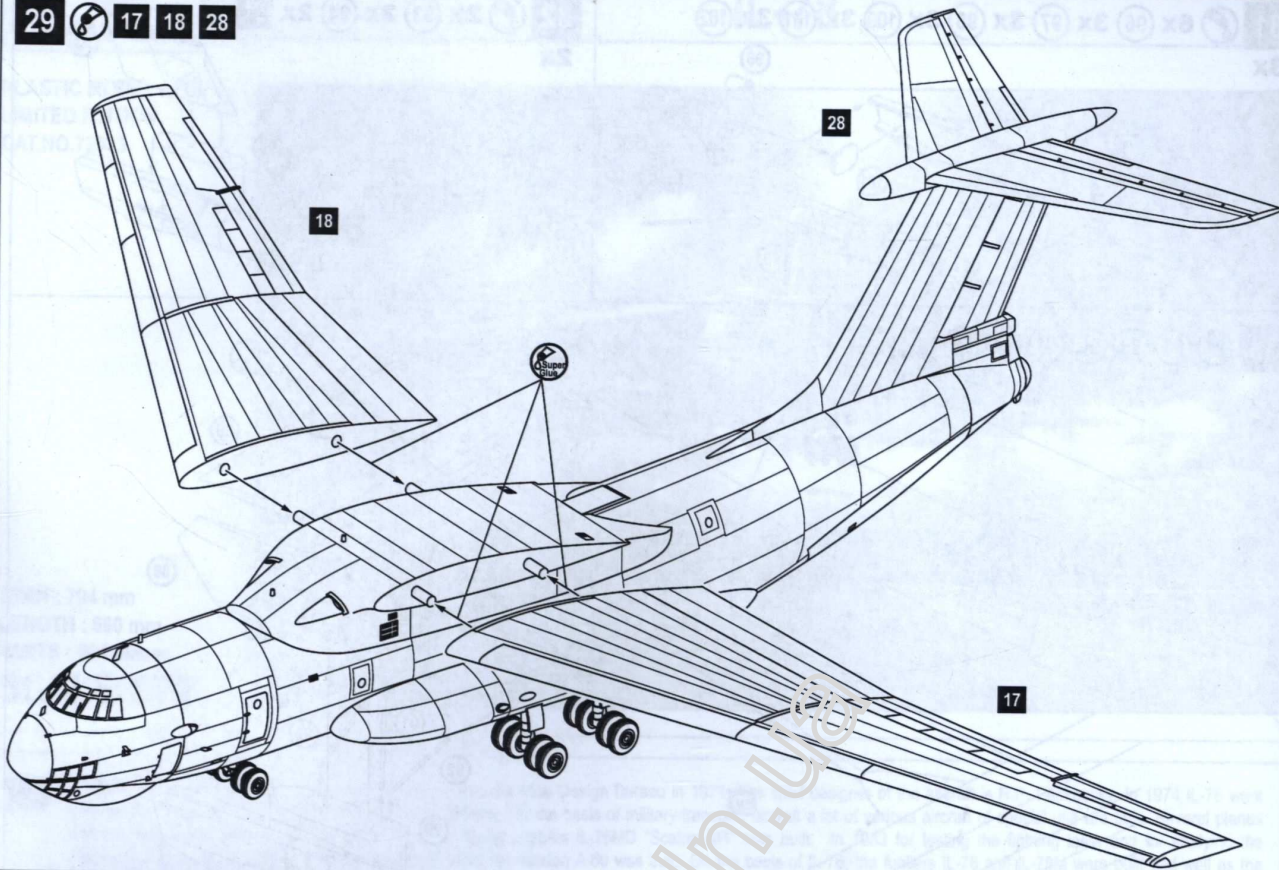

30  237 4x 27 29

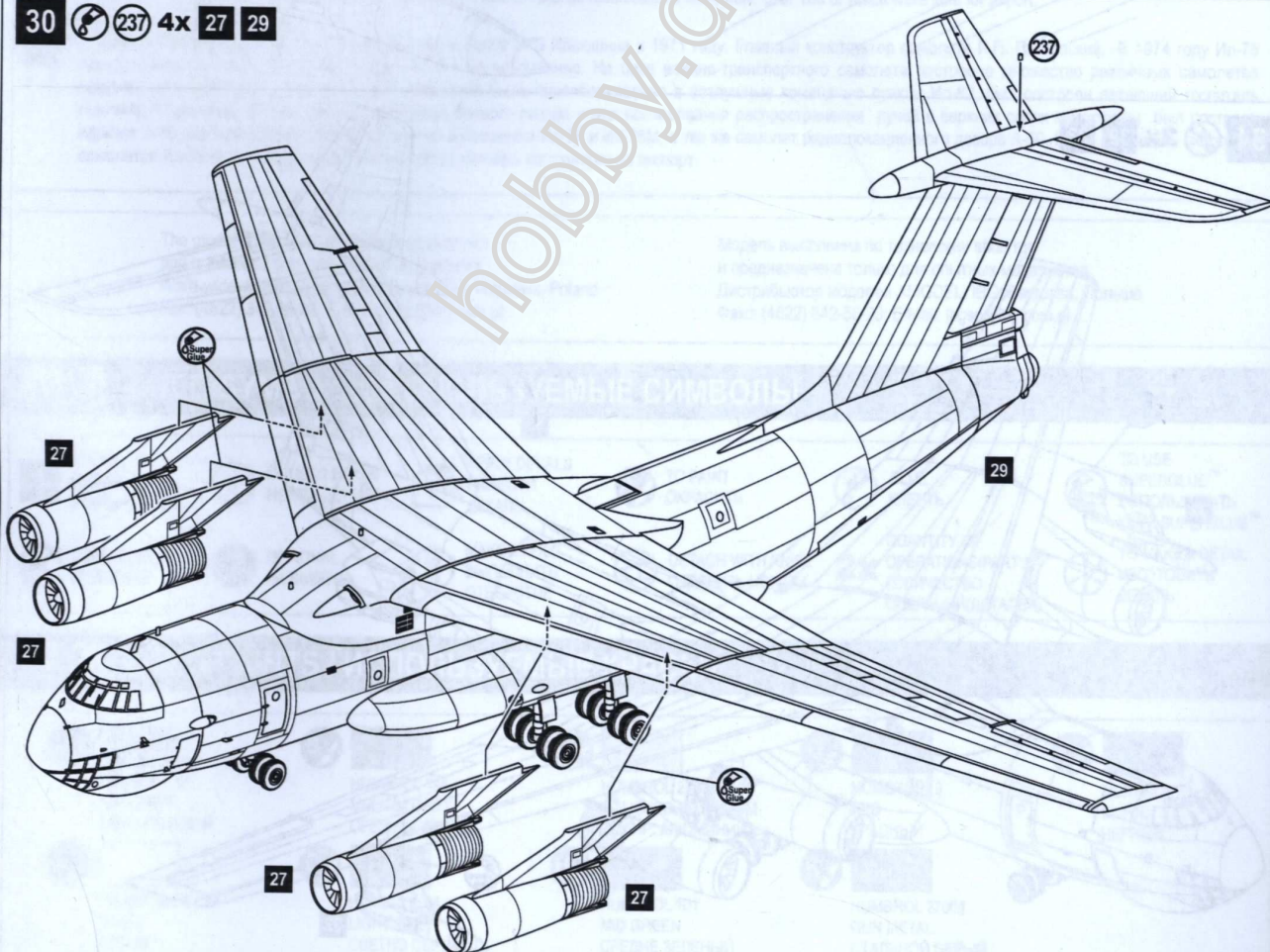

31 6x 96 3x 97 3x 98 3x 100 3x 101 3x 102
3x

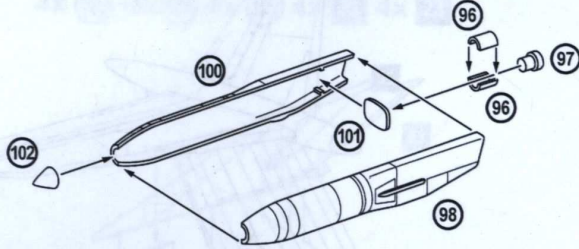

32 2x 93 2x 94 2x 31
2x

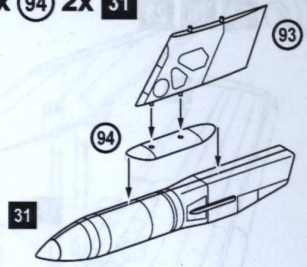

33 88 89 90 91 92 99 30 31

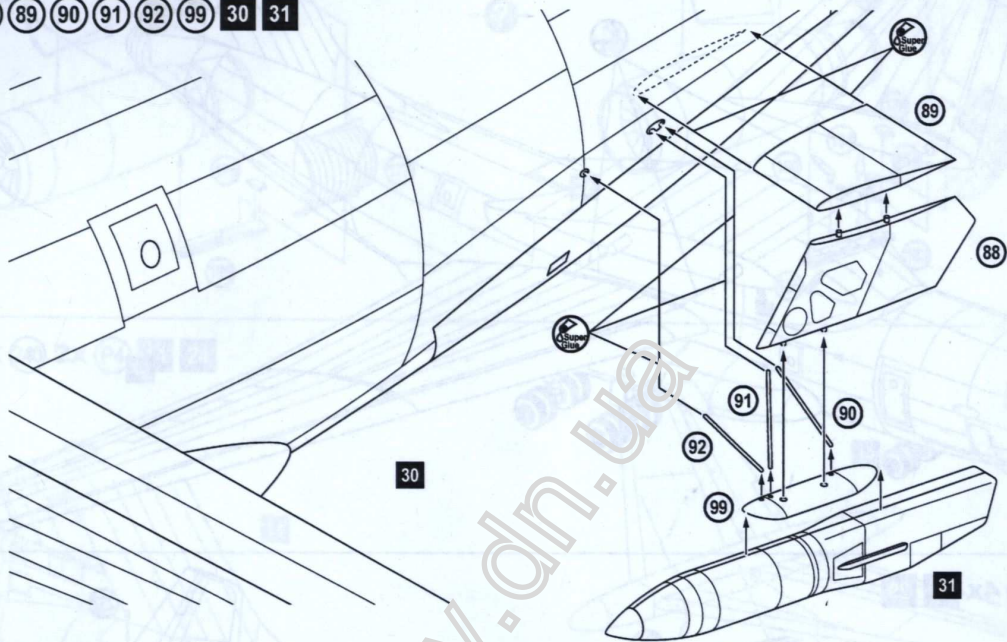

34 2x 32 33

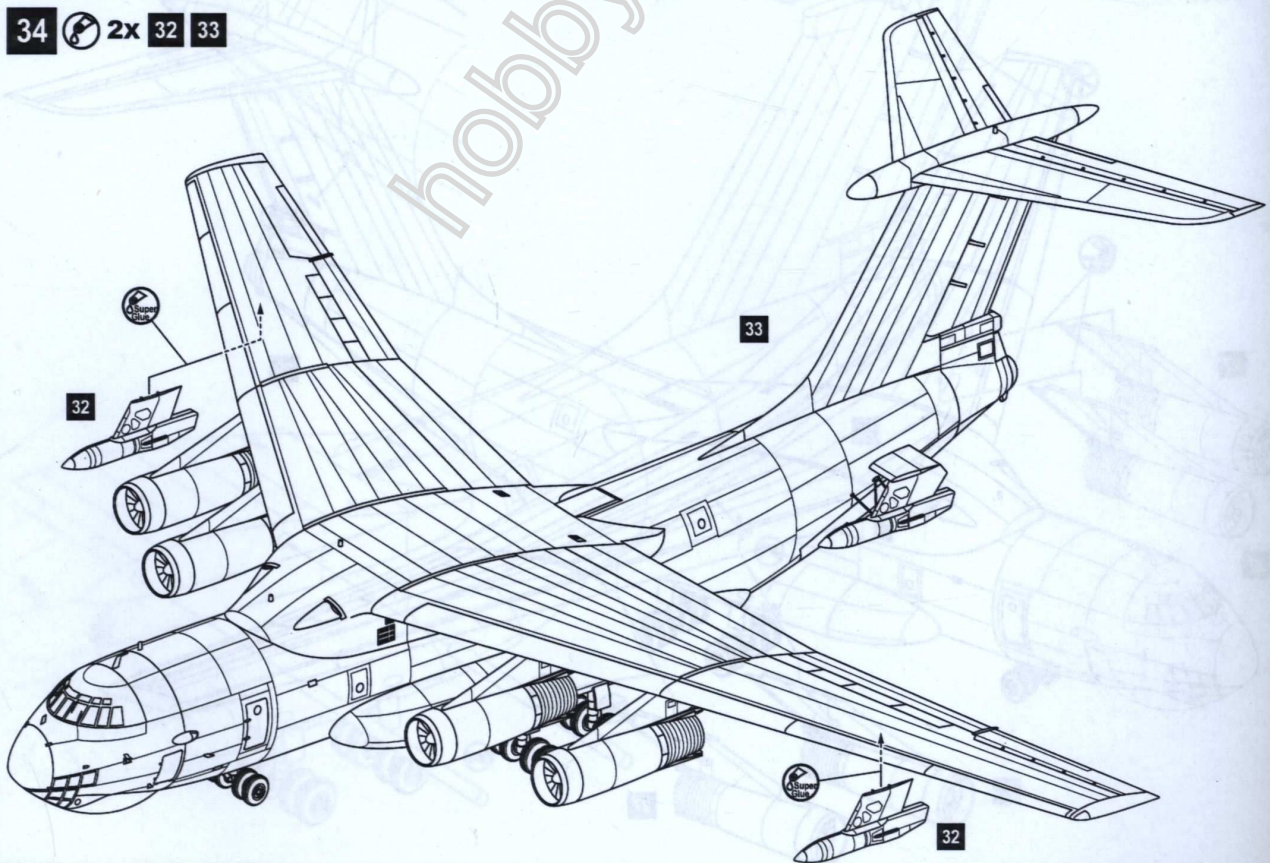

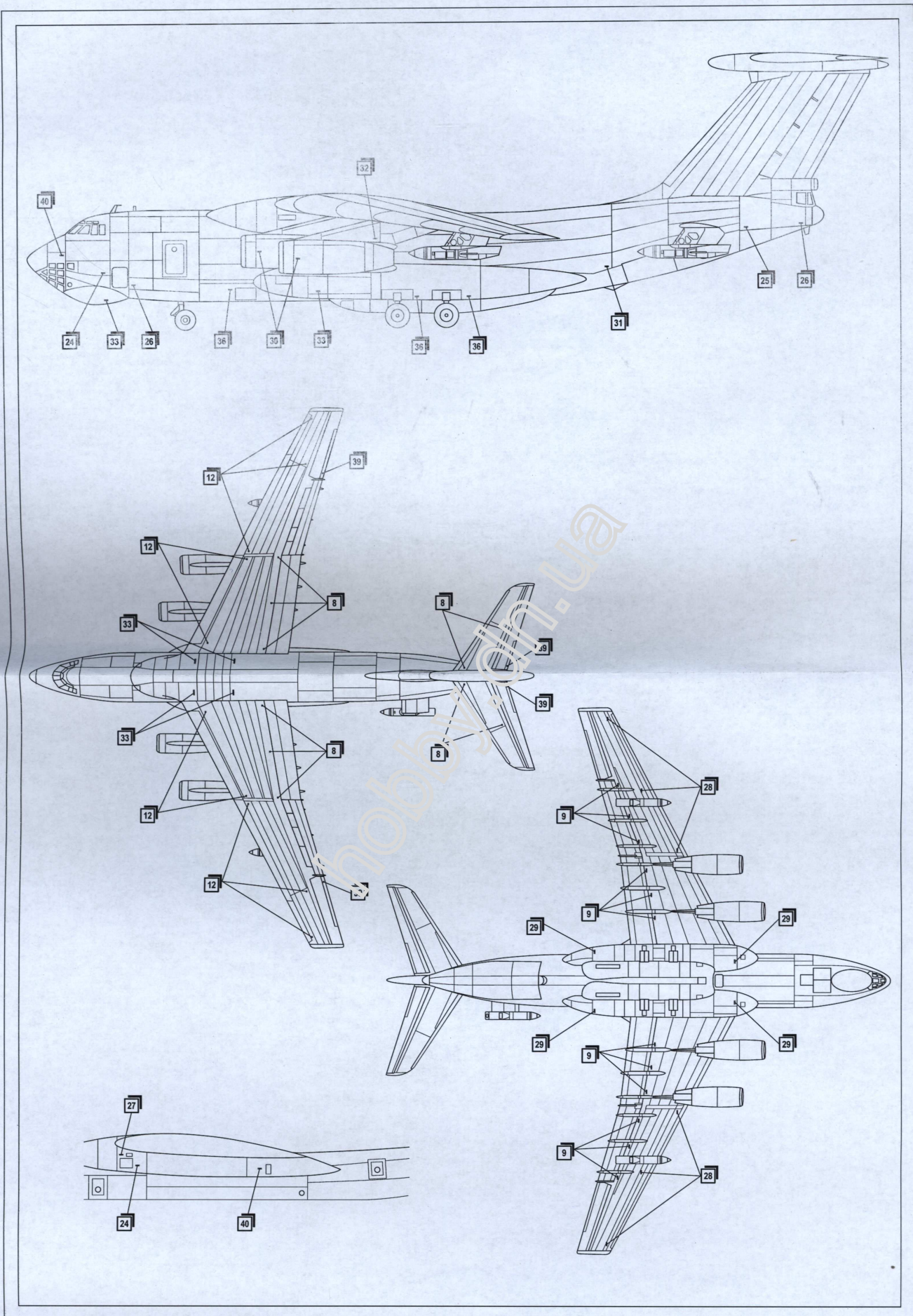

IL-78 early version, Air Force Russia
Ил-78 ранний вариант, ВВС России

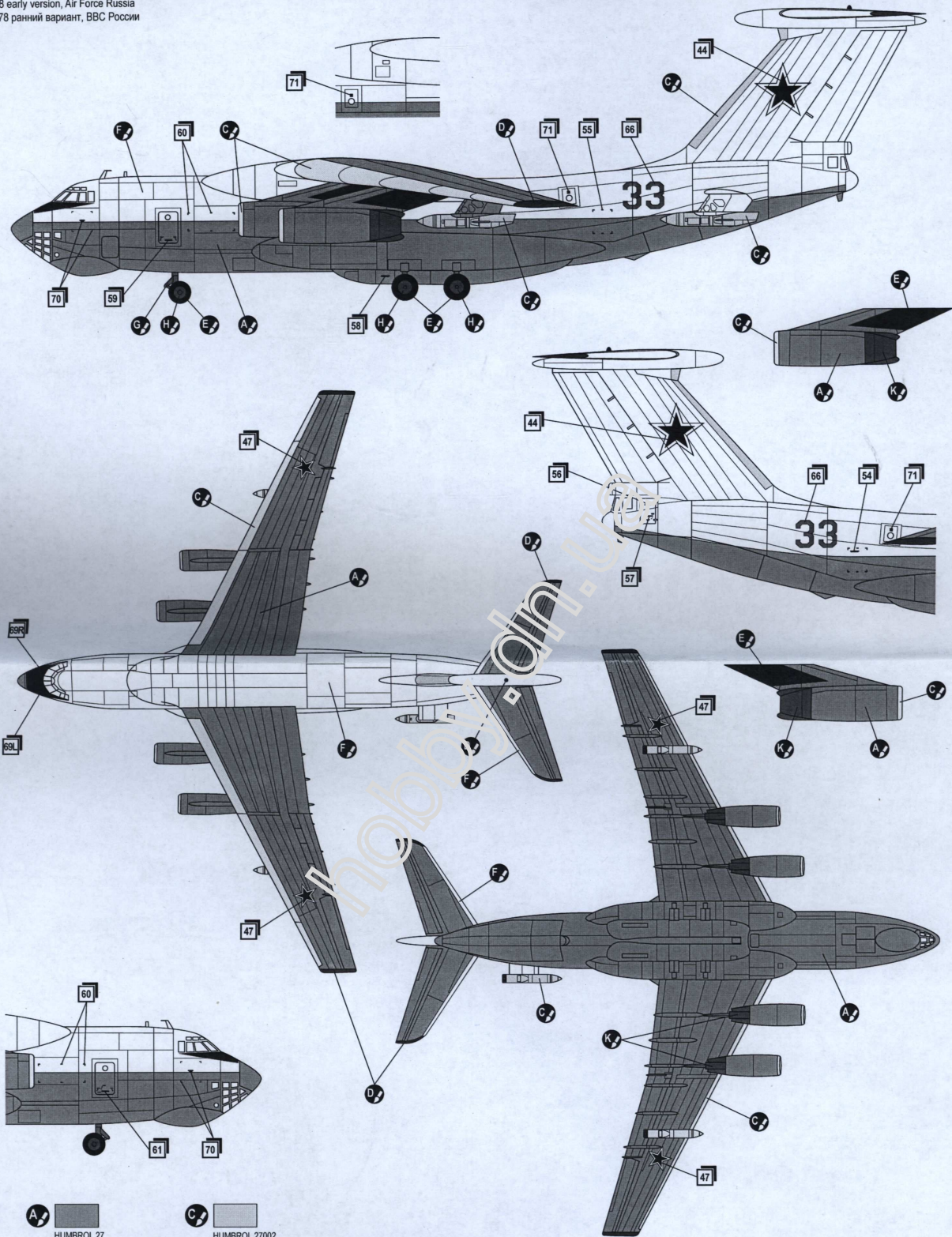

A HUMBROL 27
SEA GREY
СЕРО-ГОЛУБОЙ

C HUMBROL 27002
POLISHED ALUMINIUM
ПОЛИР. АЛЮМИНИЙ

D HUMBROL 19
RED
КРАСНЫЙ

E HUMBROL 33
BLACK
ЧЕРНЫЙ

F HUMBROL 34
WHITE
БЕЛЫЙ

G HUMBROL 64
LIGHT GREY
СВЕТЛО СЕРЫЙ

H HUMBROL 101
MID GREEN
СРЕДНЕ ЗЕЛЕНЬ

K HUMBROL 27004
GUN METAL
СТАЛЬНОЙ СЕРЫЙ

IL-78 late version, Air Force Russia
Ил-78 поздний вариант, ВВС России

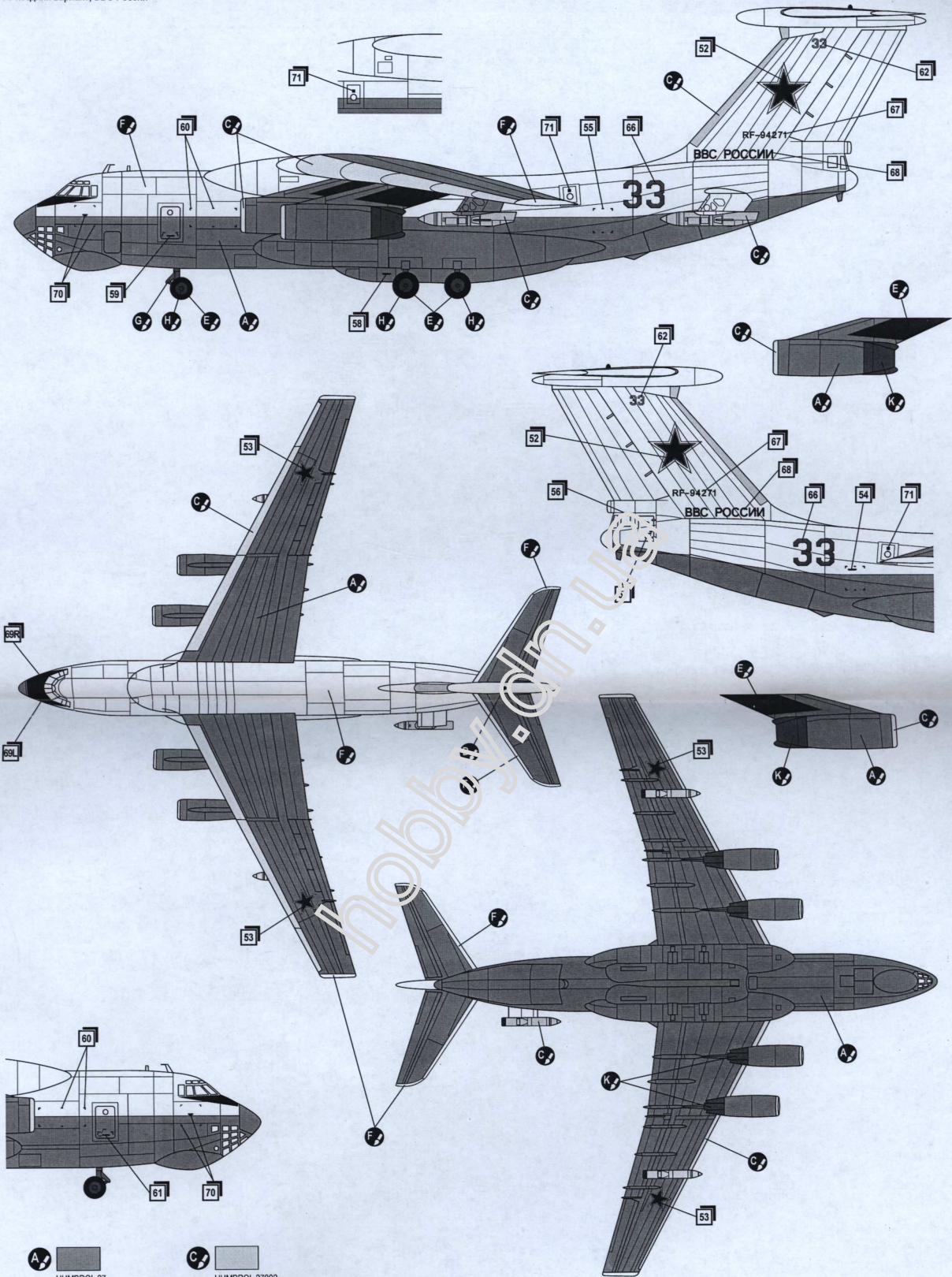

A HUMBROL 27
SEA GREY
СЕРО-ГОЛУБОЙ

C HUMBROL 27002
POLISHED ALUMINIUM
ПОЛПР. АЛЮМИНИЙ

D HUMBROL 19
RED
КРАСНЫЙ

E HUMBROL 33
BLACK
ЧЕРНЫЙ

F HUMBROL 34
WHITE
БЕЛЫЙ

G HUMBROL 64
LIGHT GREY
СВЕТЛО СЕРЫЙ

H HUMBROL 101
MID GREEN
СРЕДНЕ ЗЕЛЕНый

K HUMBROL 27004
GUN METAL
СТАЛЬНОЙ СЕРЫЙ