

PLASTIC MODEL KITS
LIMITED EDITION
CAT.NO.72293



SPAN : 262 mm
LENGTH : 257 mm
PARTS : 204 pieces
SCALE:1/72



The Dassault Falcon 50 is a French super mid-sized, long-range business jet, featuring a trijet layout with an S-duct air intake for the central engine. It has the same fuselage cross-section and similar capacity as the earlier twin-engine Falcon 20 but is a completely new design that is area ruled and includes a more advanced wing design. The first prototype flew on 7 November 1976, with French airworthiness certification on 27 February 1979, followed by U.S. Federal Aviation Administration certification on 7 March 1979.



Dassault Falcon 50 - reaktywny tróhdwигательный административный самолёт большой дальности. Основан на двухдвигательном Dassault Falcon 20 и является его развитием. Dassault Falcon 50 это трёхмоторный низкоплан с S-образным каналом для третьего двигателя. Двигатели Garret TEF731 с тягой 15,6кН. Дальность полета составляет 5830 км при полной загрузке и скорости равной 0.8 Маха. В салоне могут разместиться до 9 пассажиров. Серийное производство самолета началось в 1976 году.

The model is executed on technology short run and is intended only for experienced modelers
Word-wide distributor for AMODEL kits: IBG, Warszawa, Poland
Fax: (4822)842-56-29; E-Mail: ibgsc@ibg.com.pl

Модель выполнена по технологии short run и предназначена только для опытных моделистов
Дистрибьютор моделей AMODEL: IBG, Варшава, Польша
Факс: (4822)842-56-29; E-Mail: ibgsc@ibg.com.pl



USED SYMBOLS / ИСПОЛЬЗУЕМЫЕ СИМВОЛЫ

1

STAGES OF ASSEMBLY
ЭТАПЫ СБОРКИ

1

NUMBER PARTS
НОМЕР ДЕТАЛИ

1

APPLY DECALS
НАНЕСТИ ДЕКАЛЬ

A

TO PAINT
ОКРАСИТЬ

GLUE

КЛЕИТЬ

DONT GLUE

НЕ КЛЕИТЬ

?

OPTIONAL
НА ВЫБОР

TO BEND

СОГНУТЬ ДЕТАЛЬ

TO USE SUPERGLUE™

ИСПОЛЬЗОВАТЬ КЛЕЙ SUPERGLUE™

2x

QUANTITY OF OPERATIONS(PARTS)
КОЛИЧЕСТВО ОПЕРАЦИЙ(ДЕТАЛЕЙ)



USED PAINTS / ИСПОЛЬЗУЕМЫЕ КРАСКИ

A



HUMBROL 130
WHITE
БЕЛЫЙ

B



HUMBROL 165
GREY
СЕРЫЙ

C



HUMBROL 164
DARK GREY
ТЕМНО-СЕРЫЙ

D



HUMBROL 27003
POLISHED STEEL
ПОЛИР. СТАЛЬ

E



HUMBROL 33
BLACK
ЧЕРНЫЙ

F



HUMBROL 66
ALUMINIUM
АЛЮМИНИЙ

G



HUMBROL 121
PALE STONE
СВЕТЛО БЕЖЕВЫЙ

H



HUMBROL 27004
GUN METAL
СТАЛЬНОЙ СЕРЫЙ



COMPLETE SET / КОМПЛЕКТНОСТЬ

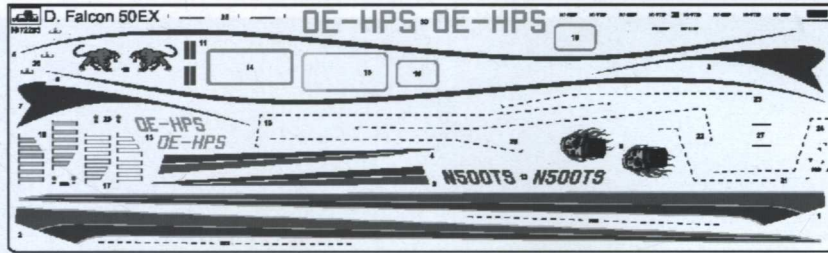

DECALS FOR TWO VERSIONS OF COLOURING
ДЕКАЛИ ДЛЯ ДВУХ ВАРИАНТОВ ОКРАСКИ

204 DETAILS FOR ASSEMBLY OF ONE MODEL
204 ДЕТАЛИ ДЛЯ СБОРКИ ОДНОЙ МОДЕЛИ

P
PARTS NOT FOR USE
ПРИ СБОРКЕ НЕ ИСПОЛЬЗУЮТСЯ

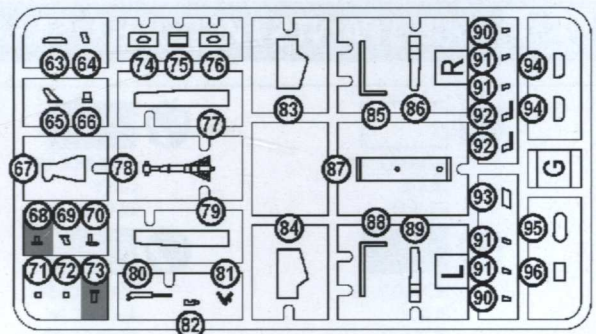
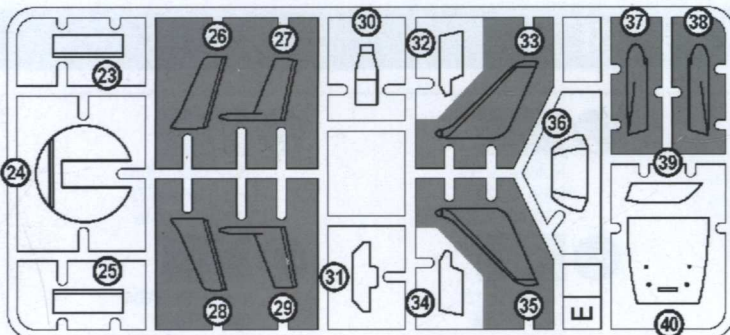
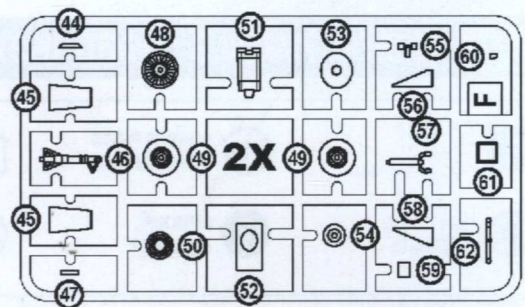
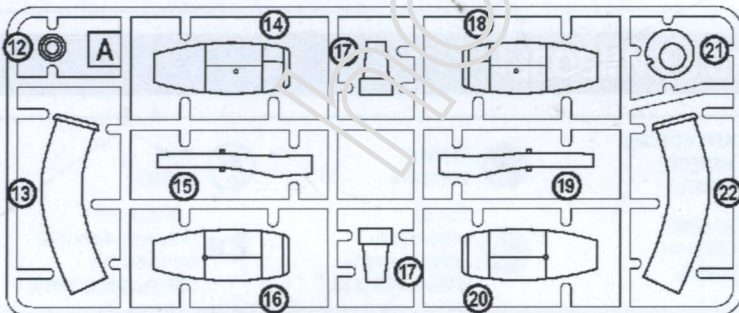
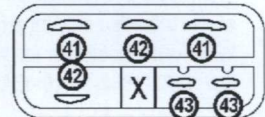
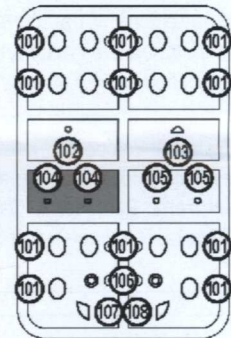
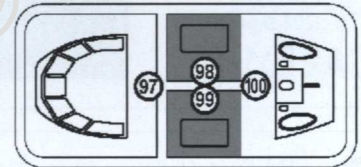
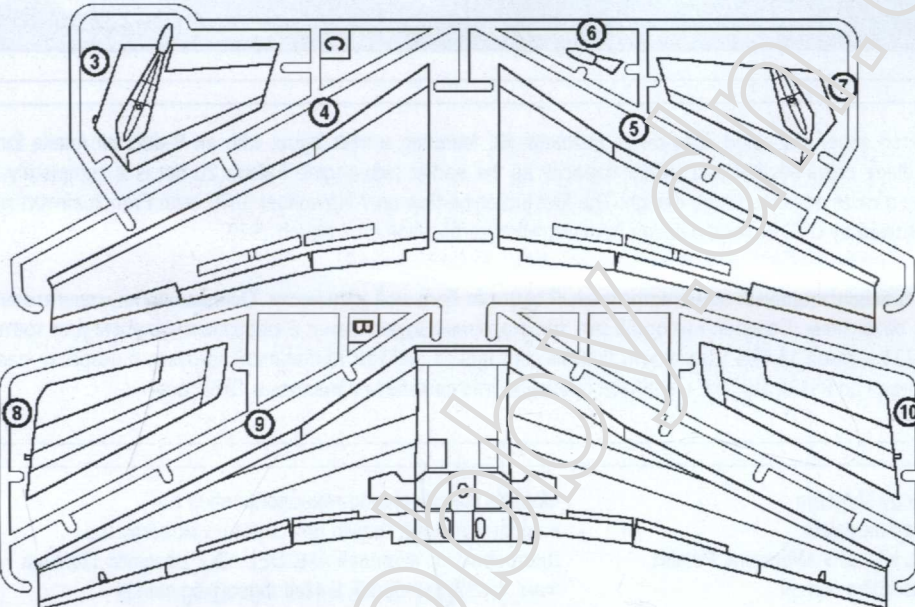
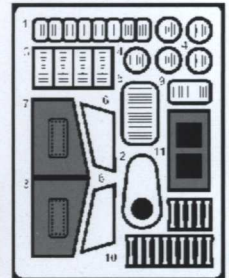
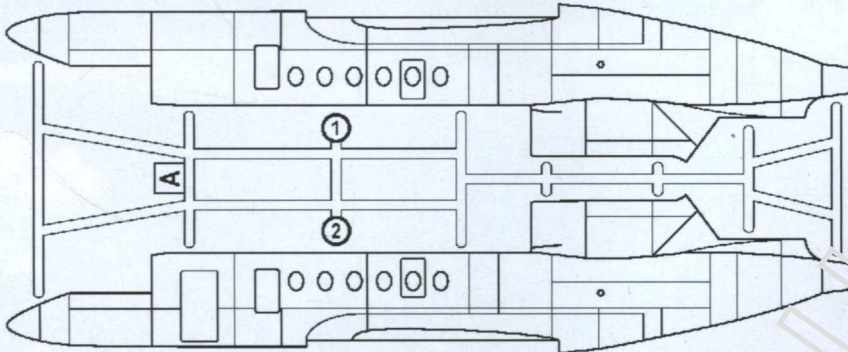

1 2x 44 2x 47 2x 51 2x 61
2x

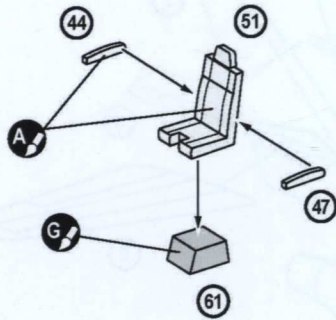

2 23 24 25 30 40 2x 55 2x 57 66 2x **1**

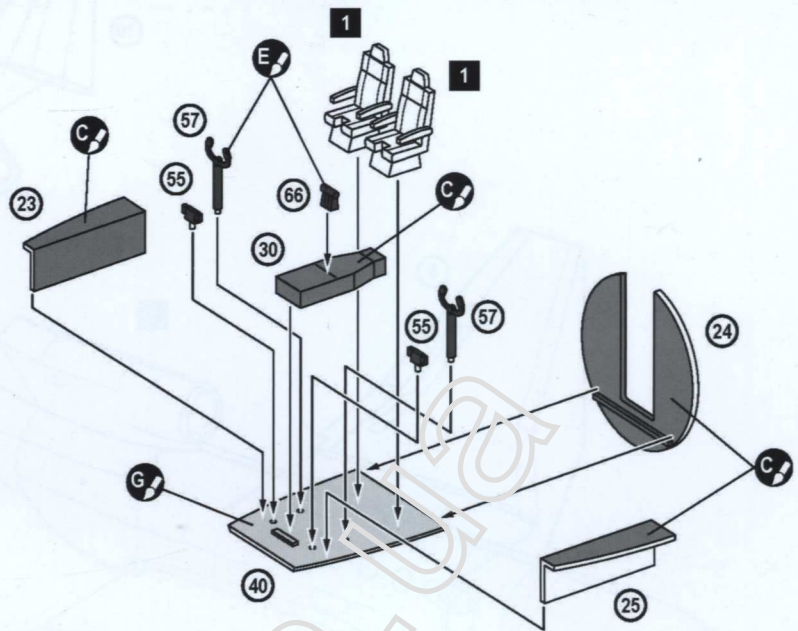

3 77 79 87

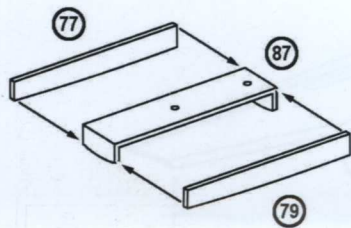

4 12 2x 17 21

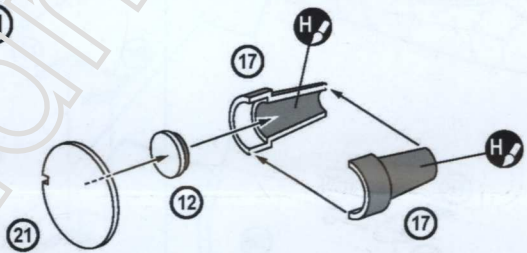

5 1 2 13 22 31 36 2x 52 97 14x 101 2 2 3 4

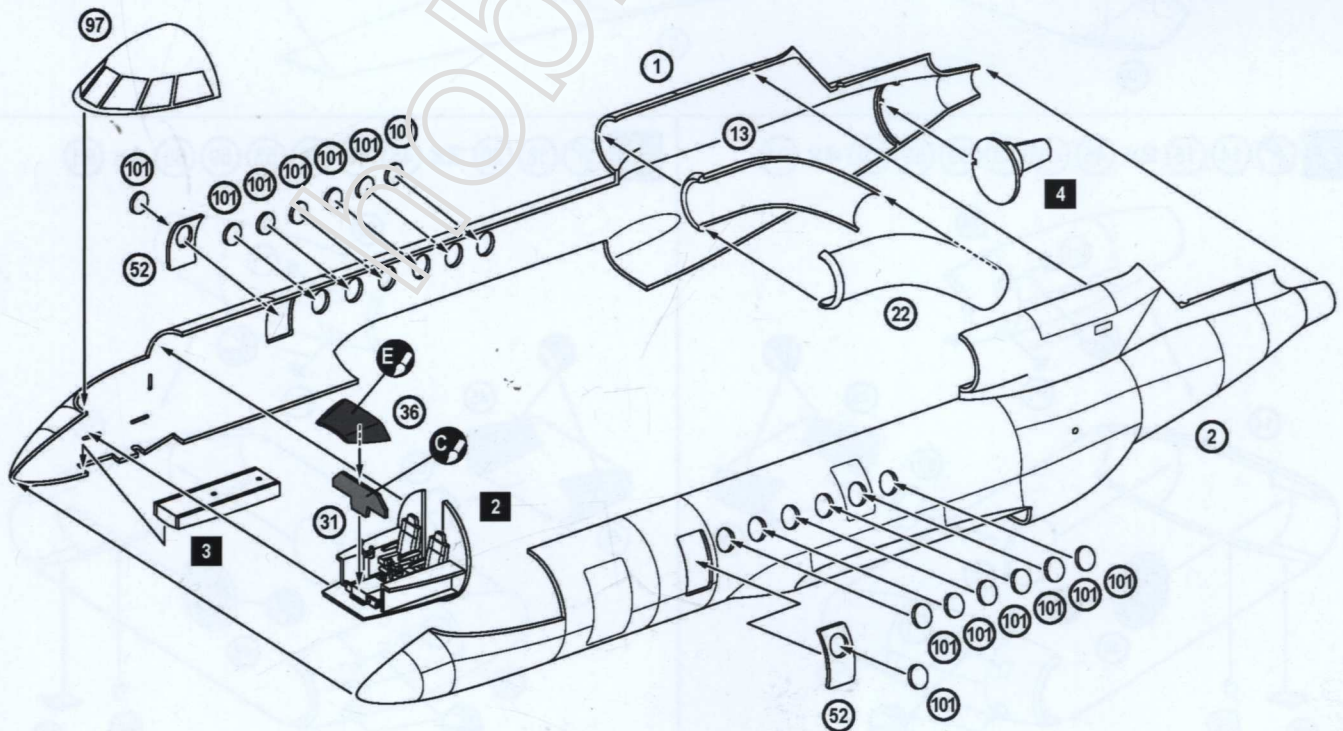

- 6** 3 4 5 6 7 8 9
 10 39 2x 56 2x 58 85
 86 88 89 100 2x 106 **5**

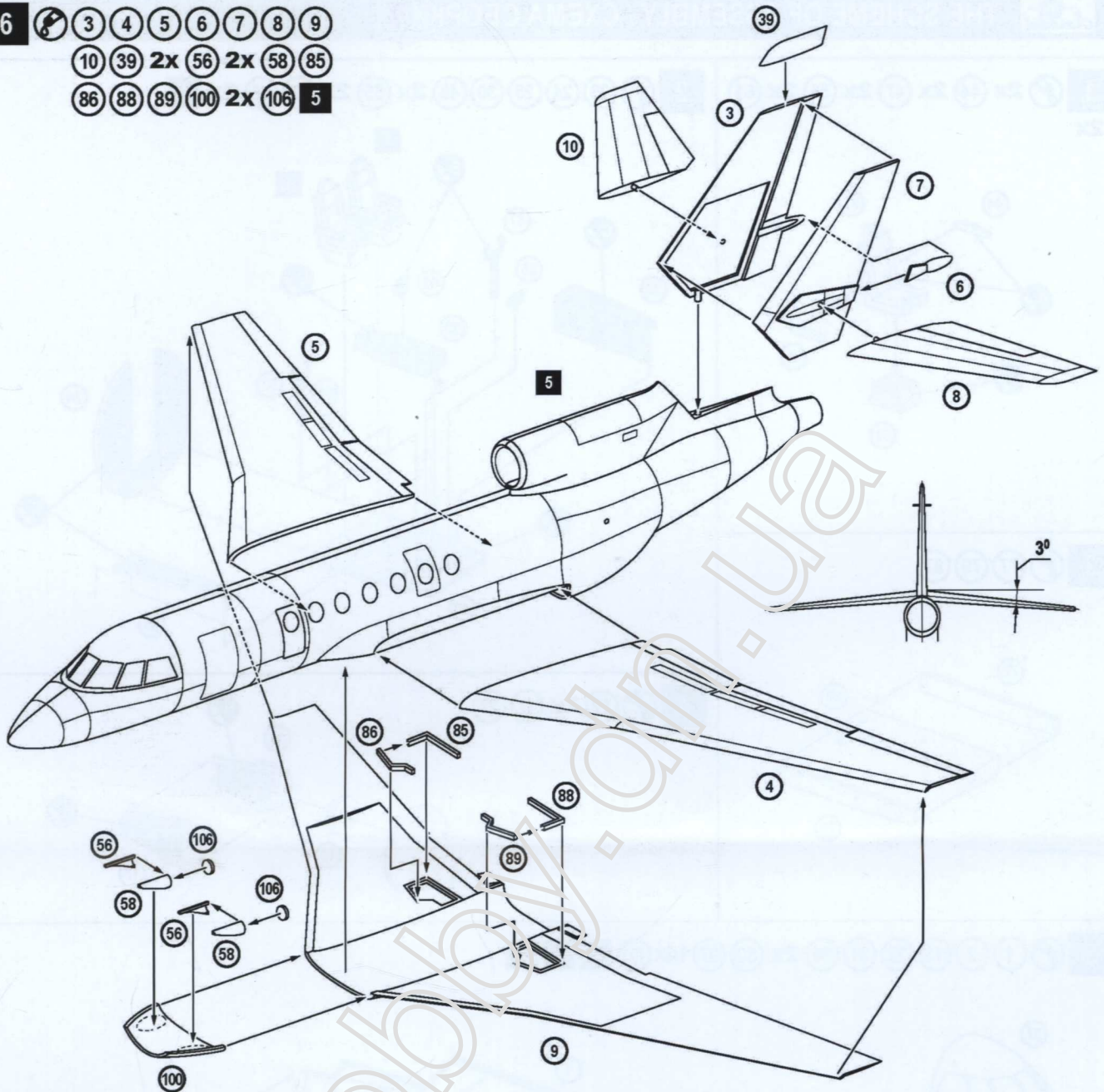

- 7** 14 16 2x 45 48 50 53 59 60 4x P1

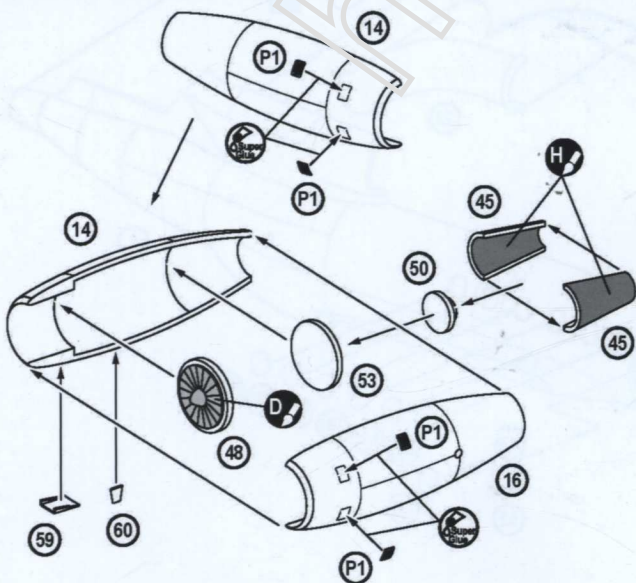

- 8** 18 20 2x 45 48 50 53 59 60 4x P1

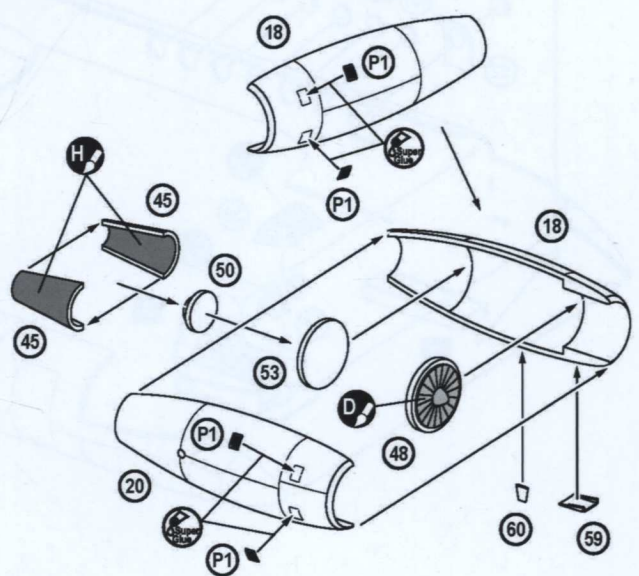

9 15 19 32 34 2x 94 107 108 6 7 8

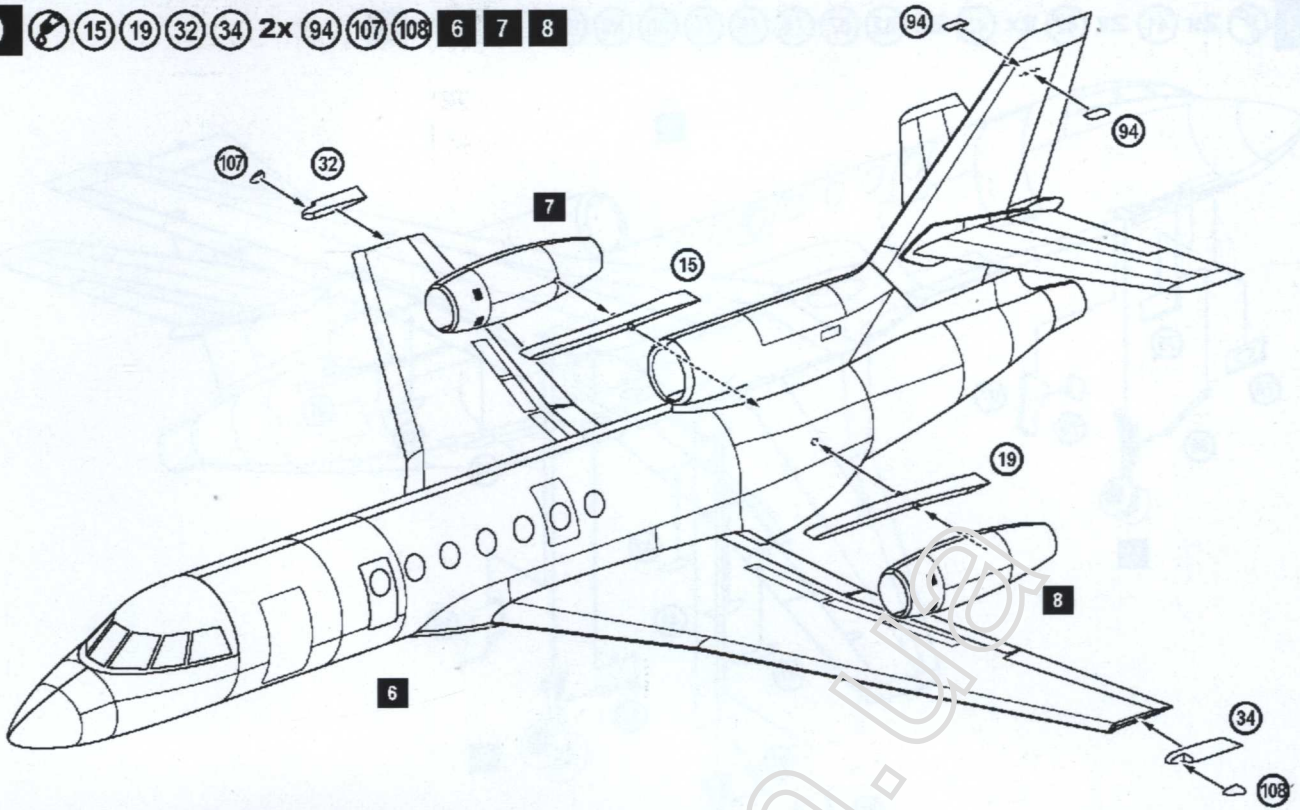

10 71 72 2x 90 2x 92
 95 96 105 P2 2x P10
 2x P12 2x P14 2x P15
 9

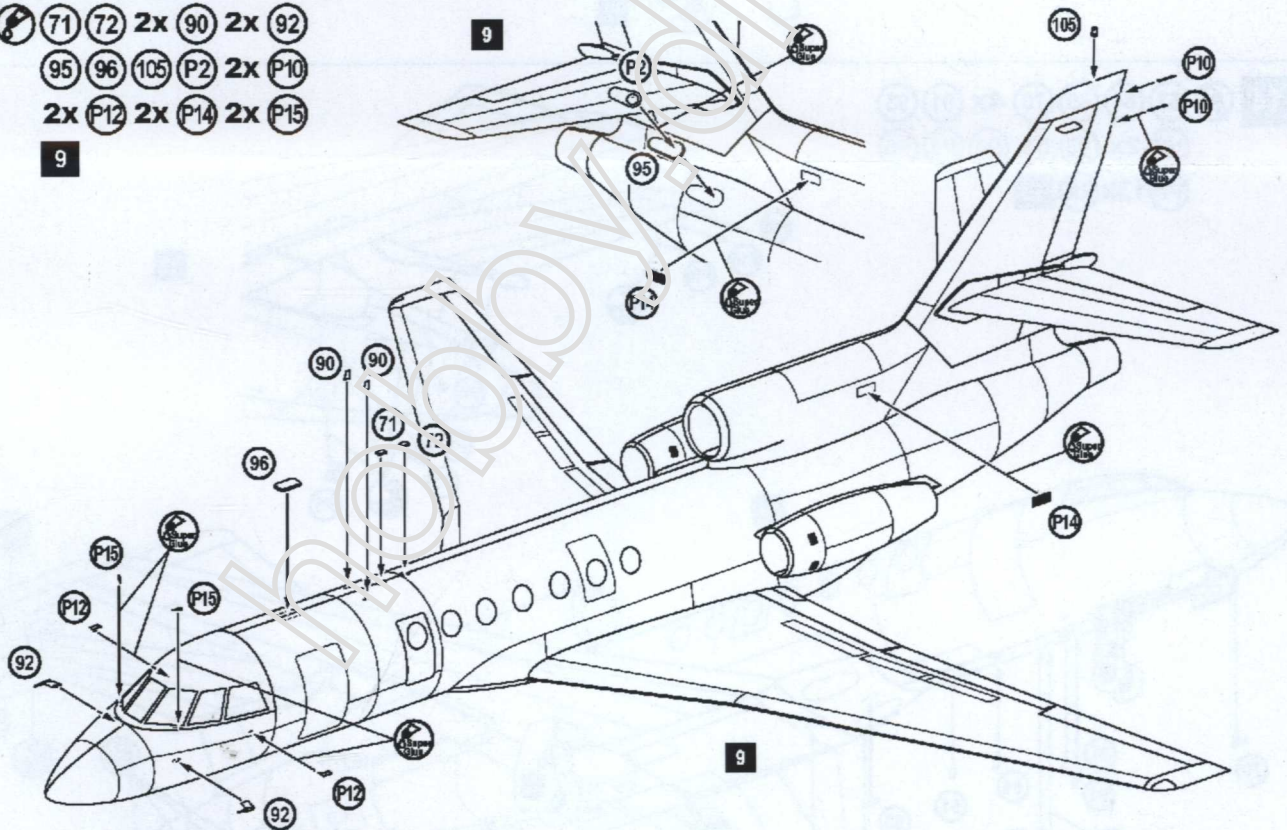

11 2x 54 78
 81 82 102

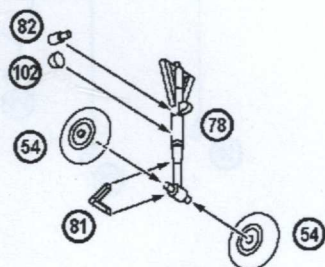

12 2x 46 4x 49
 2x

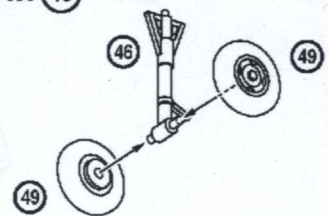

13 2x 41 2x 42 2x 43 2x 62 67 74 75 76 80 83 84 10 11 2x 12

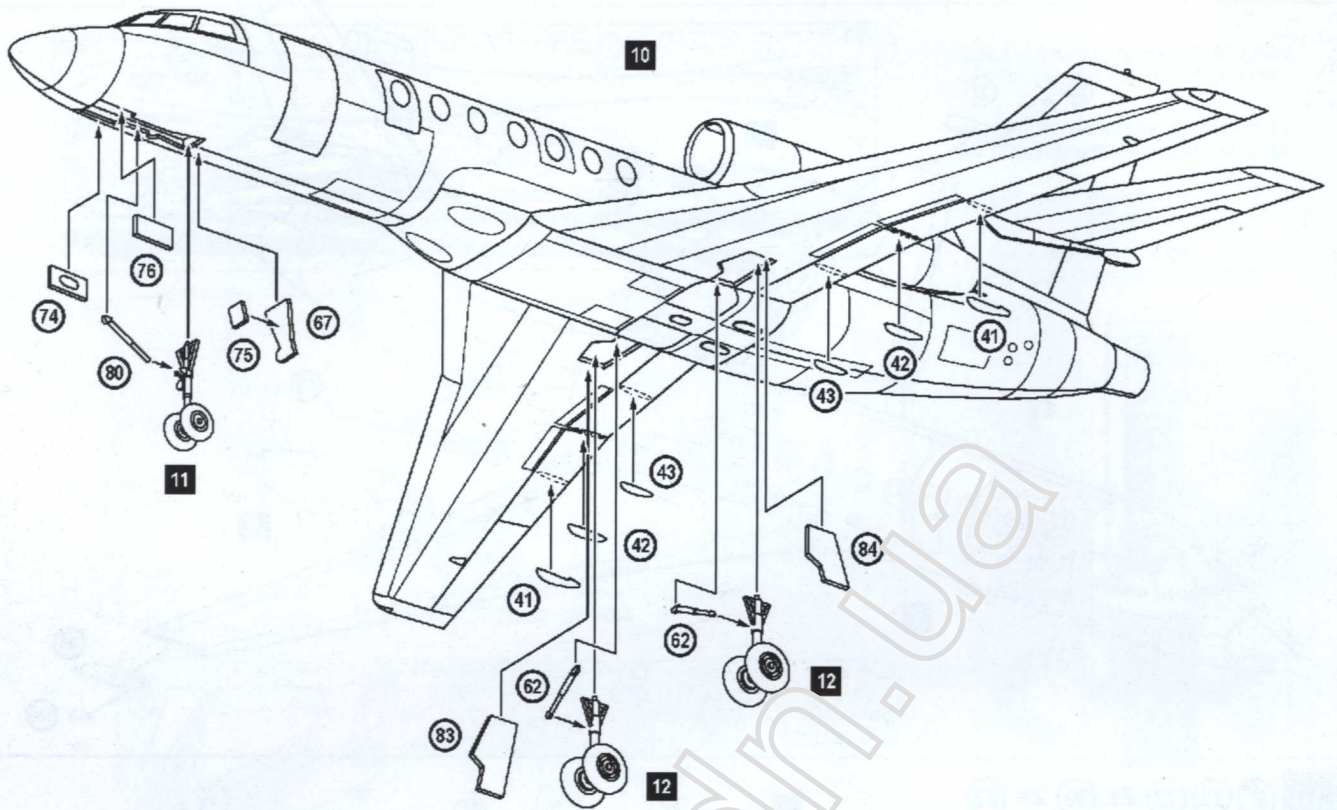

14 63 64 65 70 4x 91 93
103 2x P3 5x P4 P5 P6
P9 13x P10 13

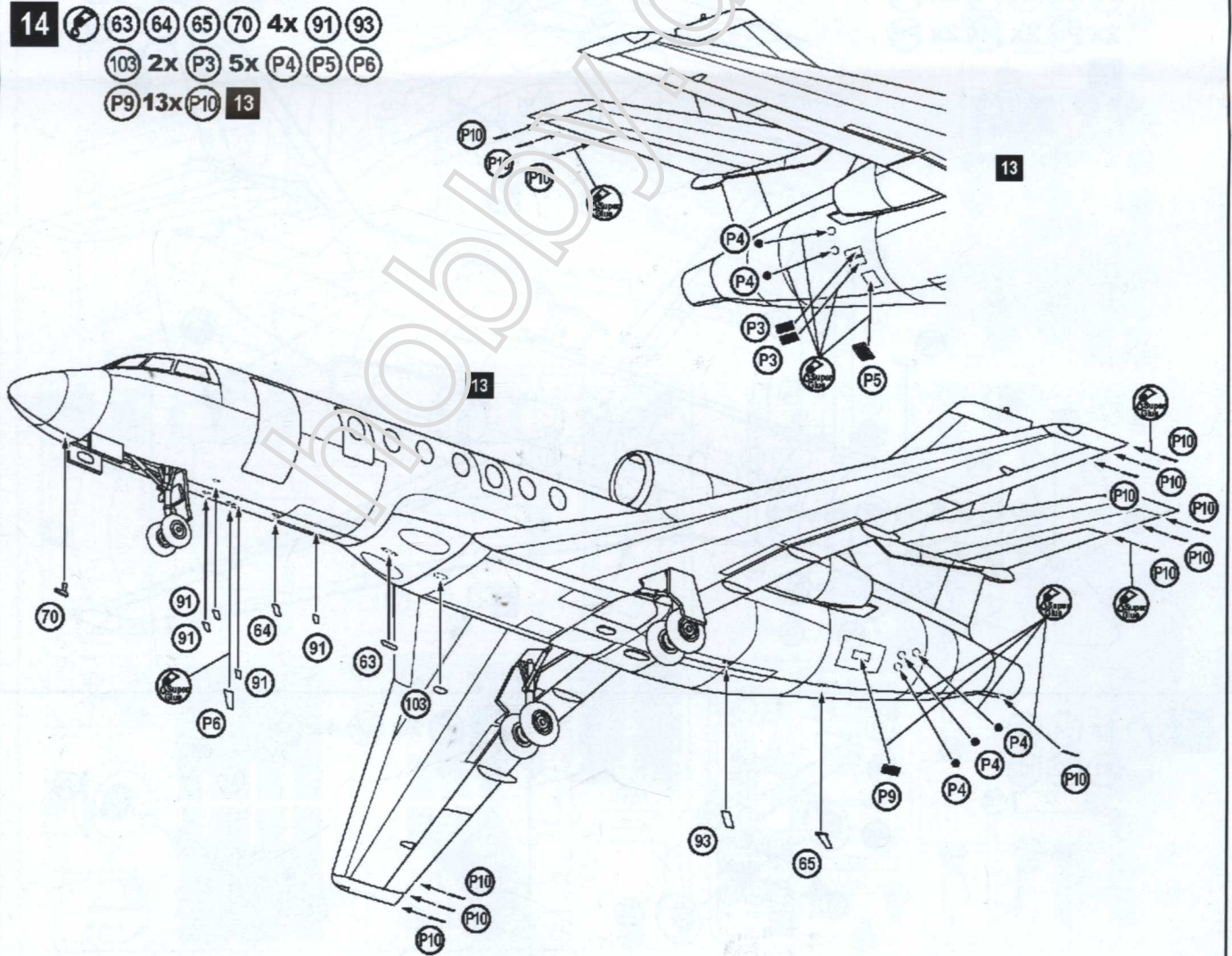



THE SCHEME OF COLOURING / СХЕМА ОКРАСКИ

Dassault Falcon 50EX



A  HUMBROL 130
WHITE
БЕЛЫЙ

D  HUMBROL 27003
POLISHED STEEL
ПОЛИР. СТАЛЬ

E  HUMBROL 33
BLACK
ЧЕРНЫЙ

F  HUMBROL 56
ALUMINIUM
АЛЮМИНИЙ

Dassault Falcon 50EX

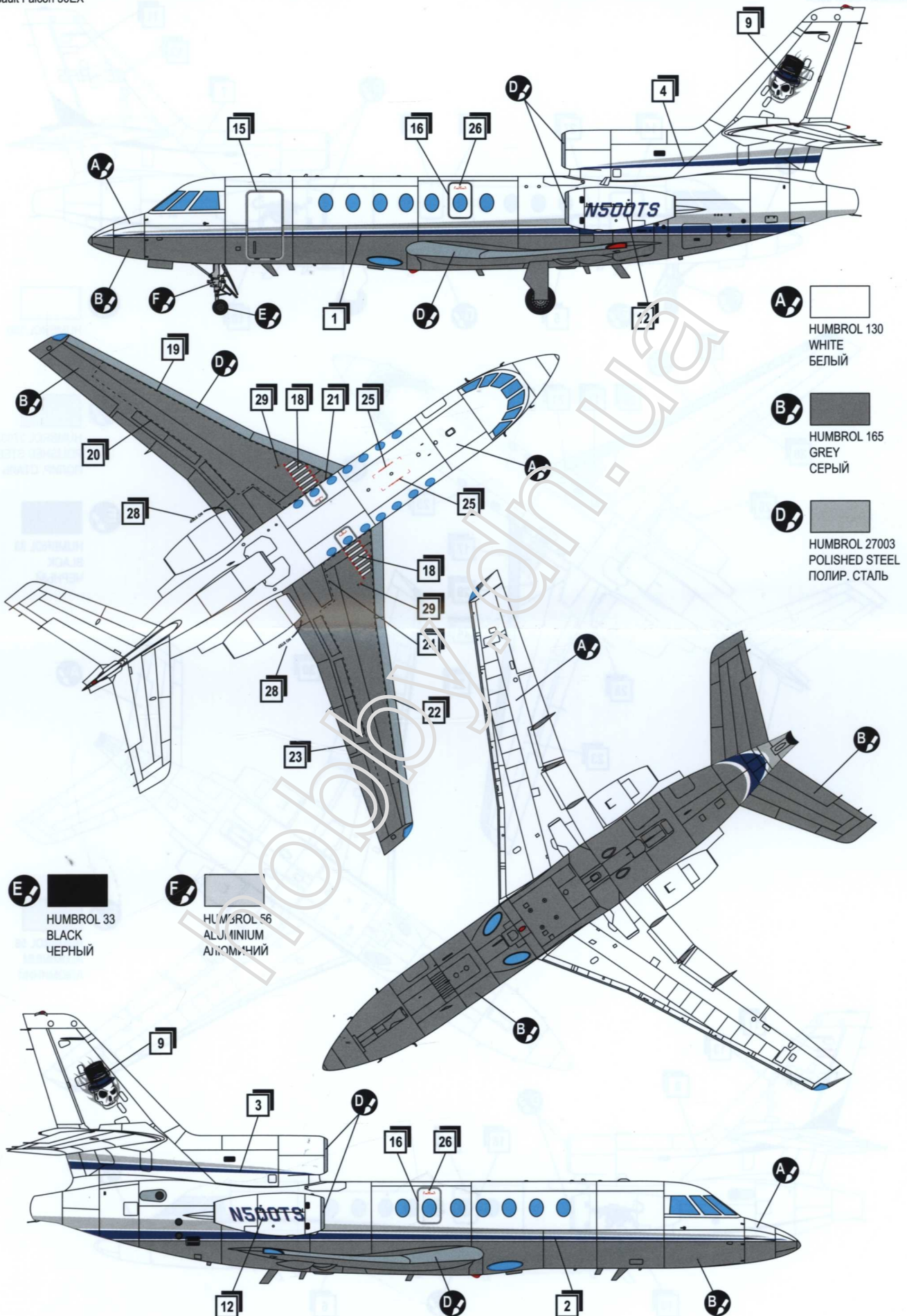

- 

HUMBROL 130
WHITE
БЕЛЫЙ
- 

HUMBROL 165
GREY
СЕРЫЙ
- 

HUMBROL 27003
POLISHED STEEL
ПОЛИР. СТАЛЬ

- 

HUMBROL 33
BLACK
ЧЕРНЫЙ

- 

HUMBROL 56
ALUMINIUM
АЛЮМИНИЙ