

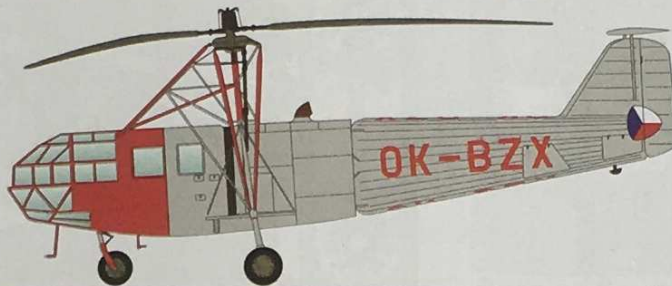

1/72 SCALE MODEL CONSTRUCTION KIT Avia VR 3/ Fa 223

72005



The first prototype V1 of Fa-223 helicopter was built by Focke-Achgelis in 1939 and made its first untethered flight on 3 August 1940 after over 100 hours of ground and tethered testing with Karl Bode at the controls. The first production version of multipurpose F 223E was production ready by 1941 but only about 20 machines were built by the end of the war.

Two Fa 223s designated as VR-1 were completed by the Československé Závody Letecké (formerly Avia) factory in Czechoslovakia in 1945–1946 from salvaged components.

Вертоліт Fa-223 був побудований фірмою «Focke-Achgelis» в 1939. Прототип Fa 223 V1 випробували в жовтні 1939. Капітан Карл Боде 3 серпня 1940 здійснив на ньому перший політ.

З 1941 до серійного виробництва підготували модель Fa 223 E, як багатоцільового вертольота.

До кінця війни вдалося зібрати близько 20 вертольотів. Після війни, в Чехословаччині на заводі Avia зібрали 2 Vr-1 із запчастин Fa 223.

Технічні характеристики / Technical specifications:

Довжина/Length - 12.25 м; Діаметр ротора/Rotor diameter - 12,00 м; Висота/Height - 4,35 м; Злітна вага (макс.)/Loaded weight - 4315 kg; Дальність польоту/Range - 700 км; Крейсерська швидкість/Cruising speed - 120 км/ч; Макс. висота польоту/Ceiling - 4880 м; Кількість пасажирів/Number of passengers - 4.

СПЕЦІАЛЬНІ СИМВОЛИ/USED SYMBOLS



CEMENT
КЛЕЯТИ



DON'T CEMENT
НЕ КЛЕЯТИ



REMOVE
ВІДРІЗАТИ



SYMMETRICAL
СИМЕТРИЧНО



x2
MULTIPLE
КРАТНО



BEND
ЗІГНУТИ



OPEN WHOLE
СВЕРДЛИТИ



VARIANTS
ВАРІАНТИ



TO PAINT
ФАРБУВАТИ

КОЛЬОРИ ФАРБ/USED PAINTS



White



Black
RLM 22



Dark Grey
RLM 66



Dark green
RLM 71



Light Blue
RLM 65



Grey
RLM 02



Silver



Steel



Red

PARTS OF THE MODEL

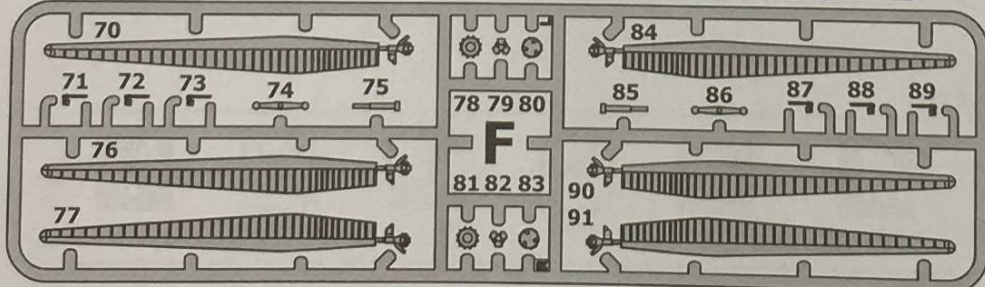
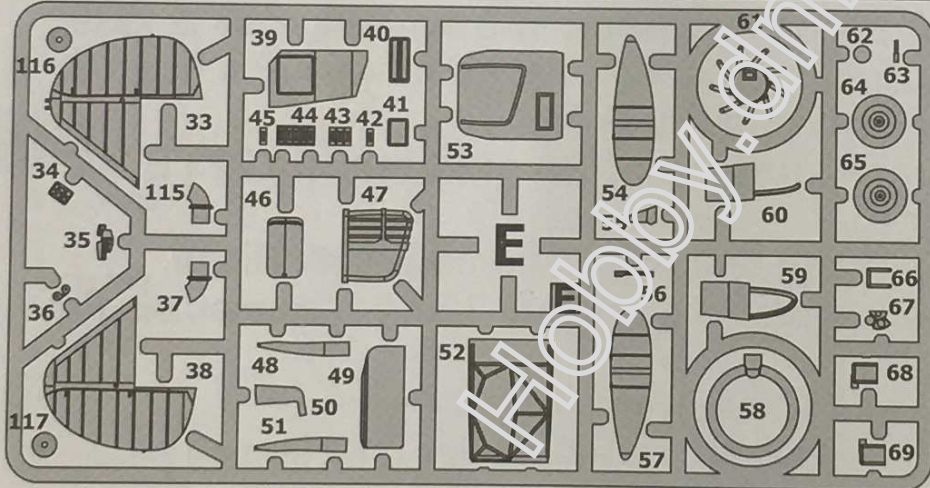
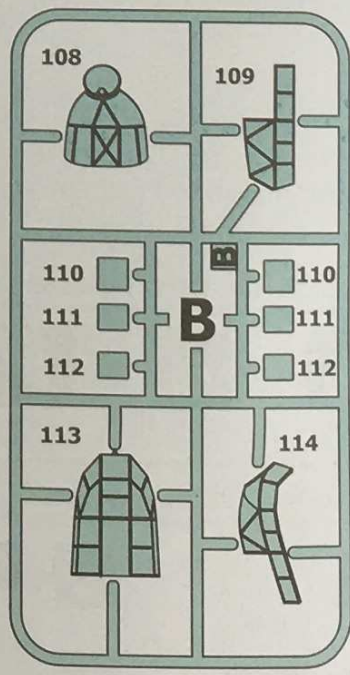
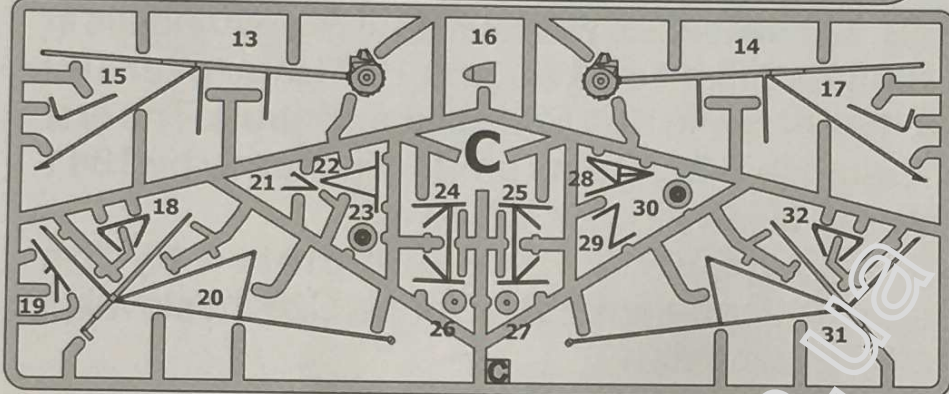
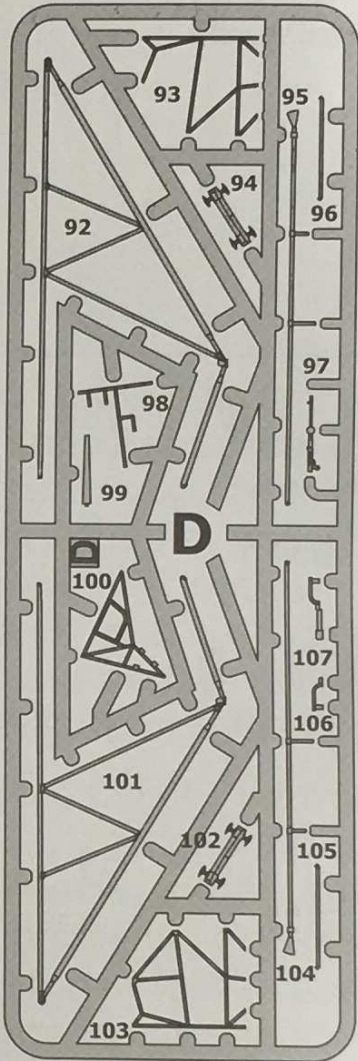
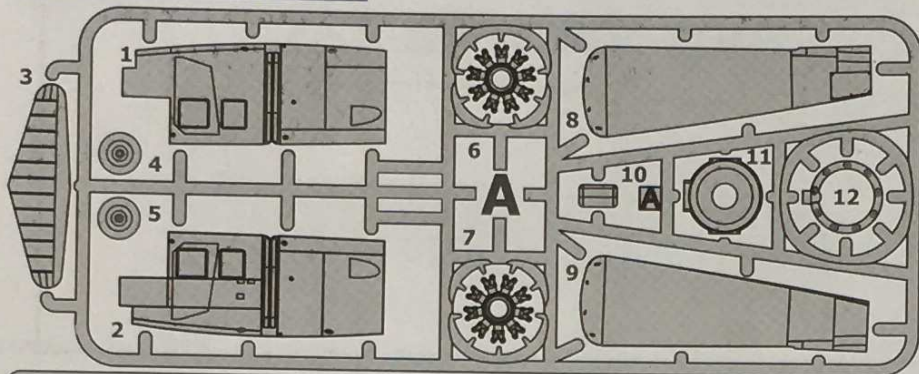

PE

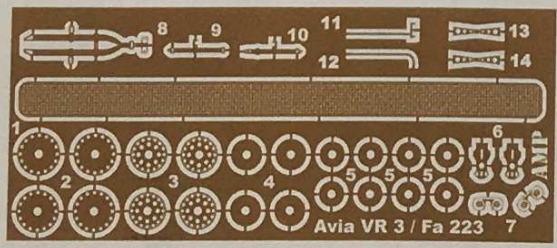

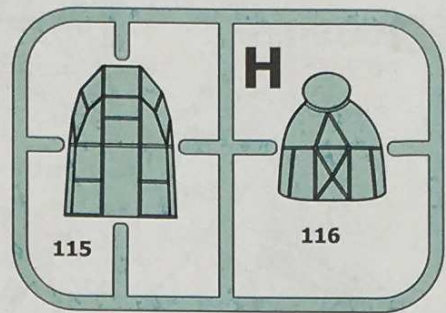
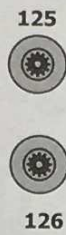
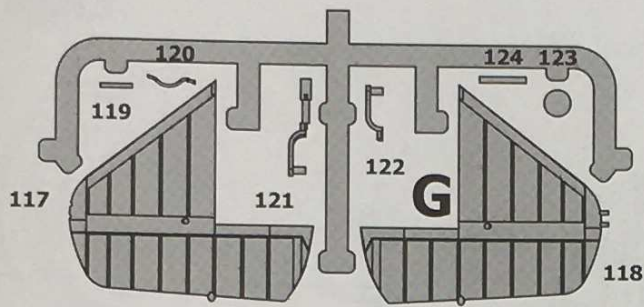

ASSEMBLY INSTRUCTION

1 E34, E35, D98

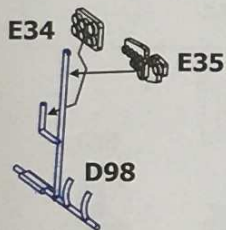

2 E42, E43, E44, E45, D100

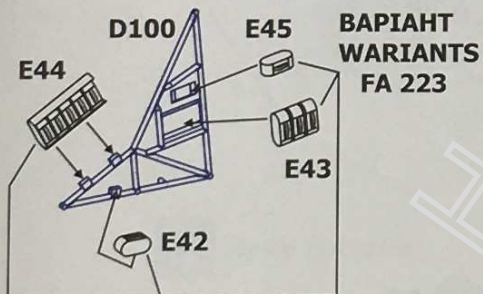

3 C23, C30, D106, D107

BAPIAHT
WARIANTS
FA 223

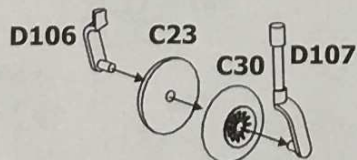

BAPIAHT
WARIANTS
VR 3

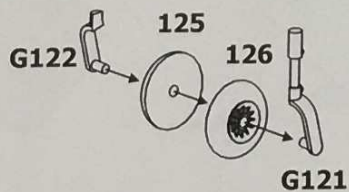

4 A10, E47, E49, E52, E53, E59-60, D93, D103

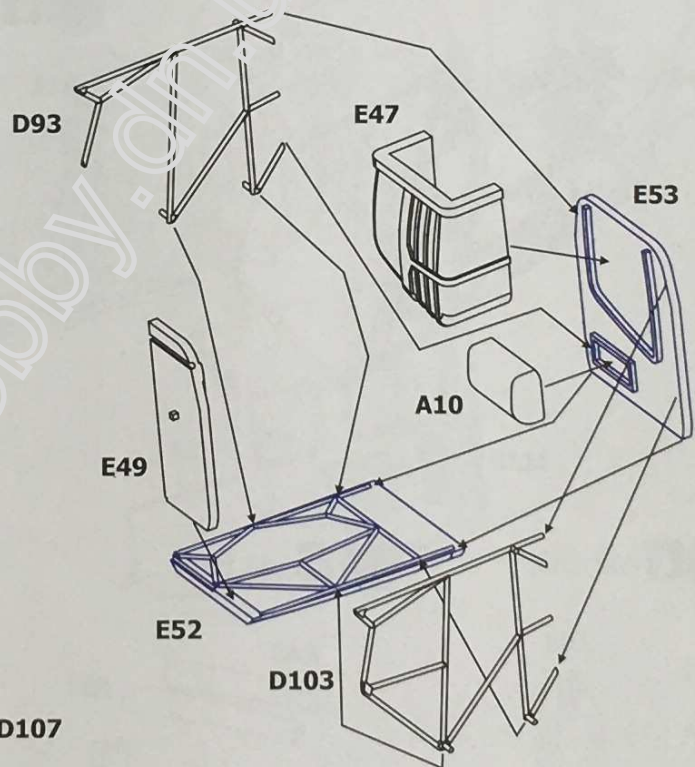

5 E40, E41, E46, E55, E56, C19, C22, C28, C29

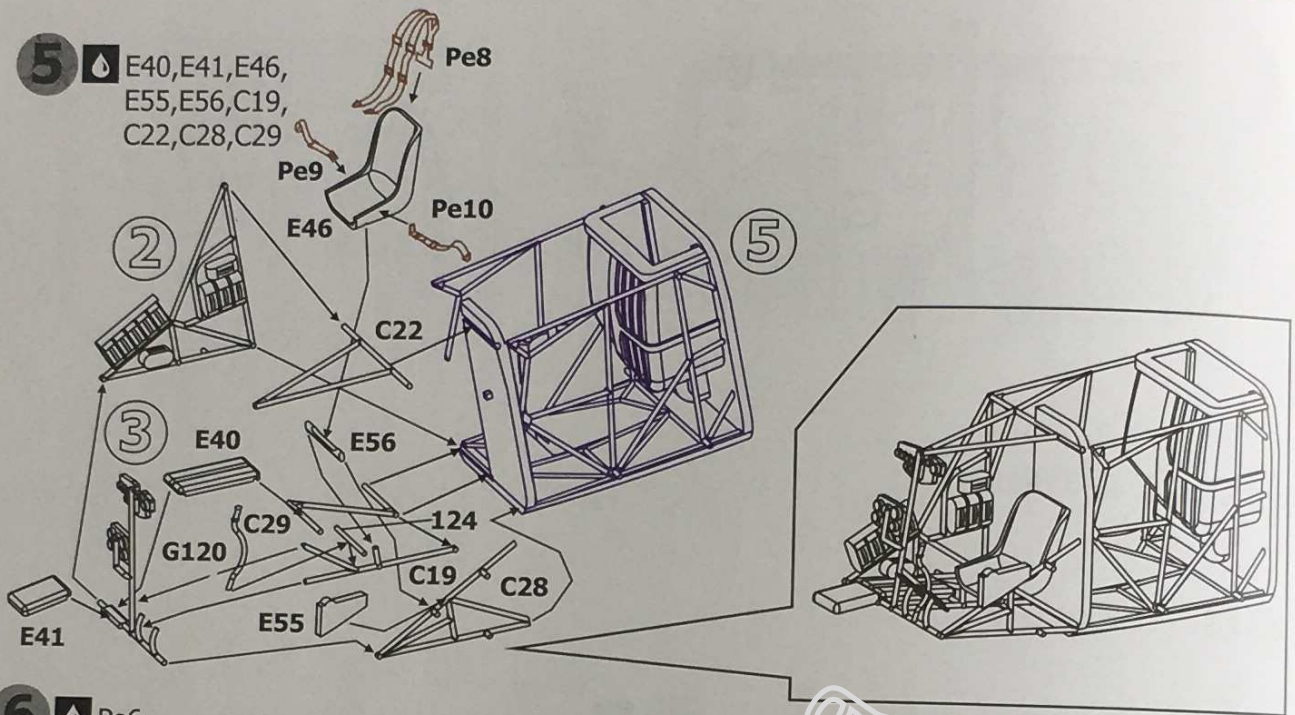

6 Pe6

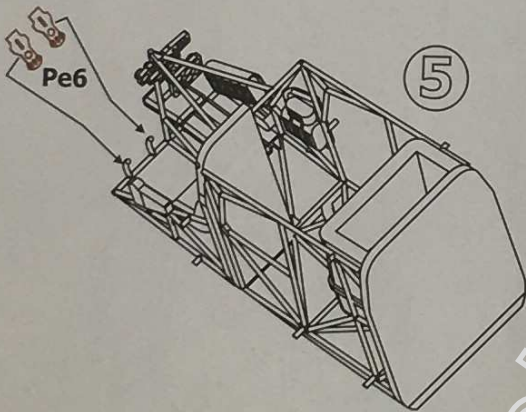

7 A6, A7, A11, E61

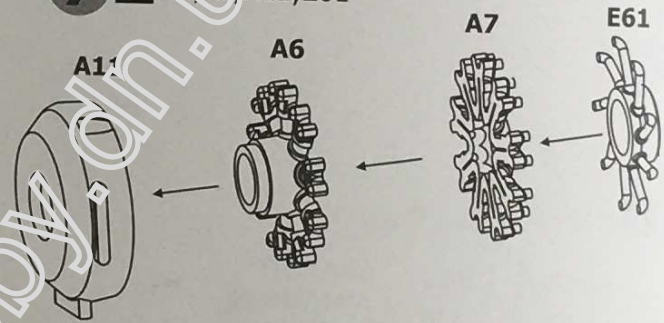

8 A12, E58

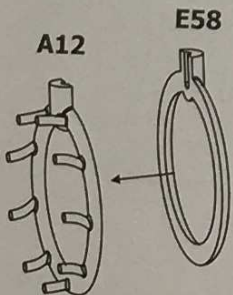

9 E48, E51

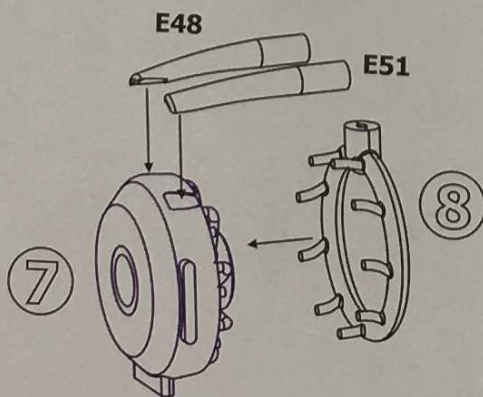

10 E50, E67, E68, E69

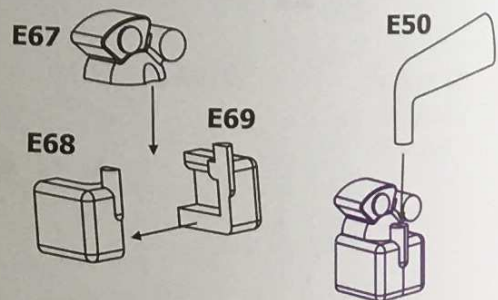

11

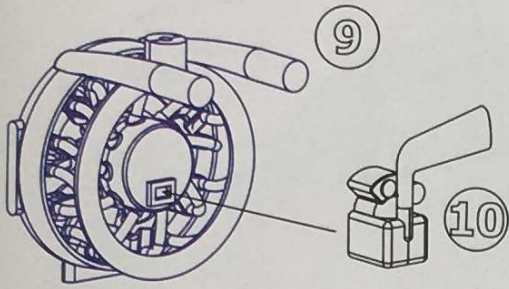

12 C18,C24,C25,C32

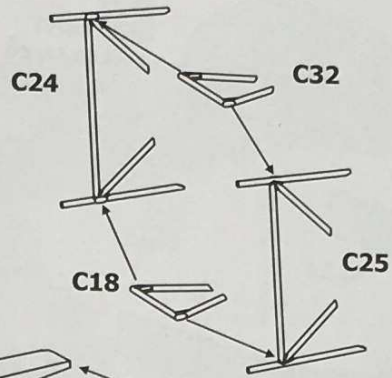

13 A1,A2,B110x2,B111x2

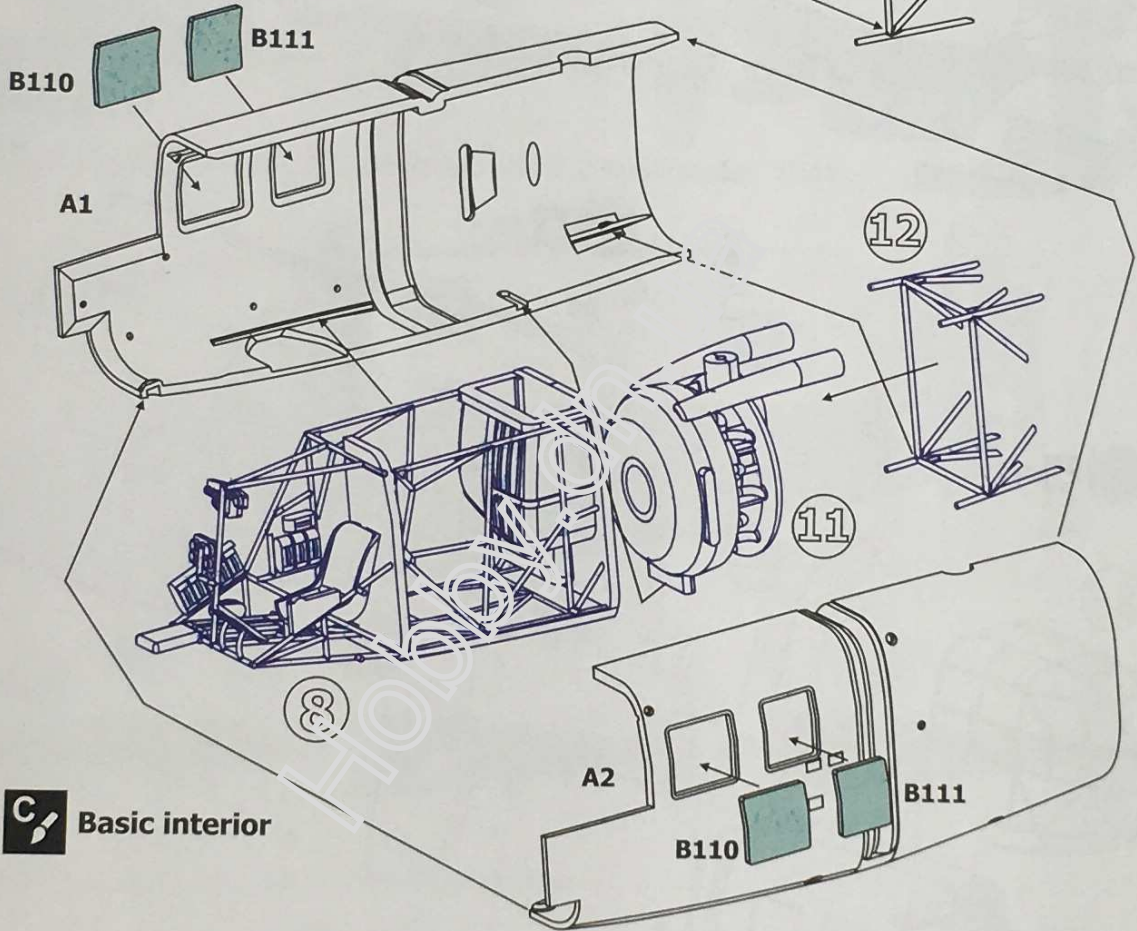

C Basic interior

13 E36,D97,Pe7

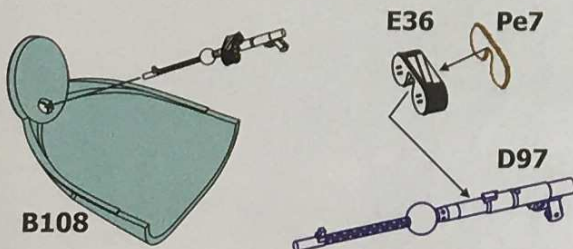

**BAPIAHT
WARIANTS
FA 223**

14  A108,A109,A113,A114

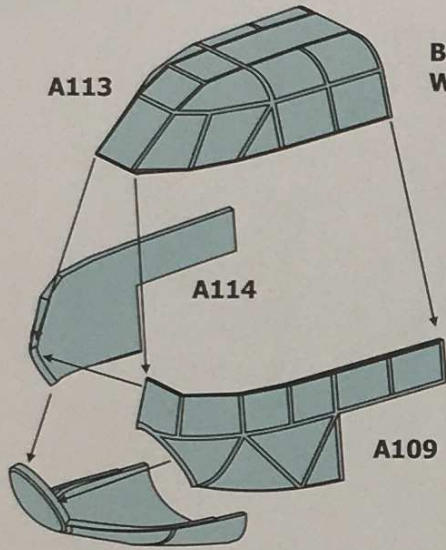

13

BAPIAHT
WARIANTS
FA 223

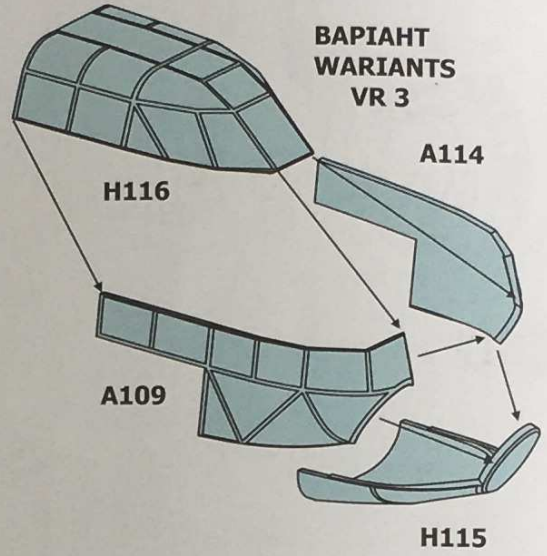

15  A8,A9

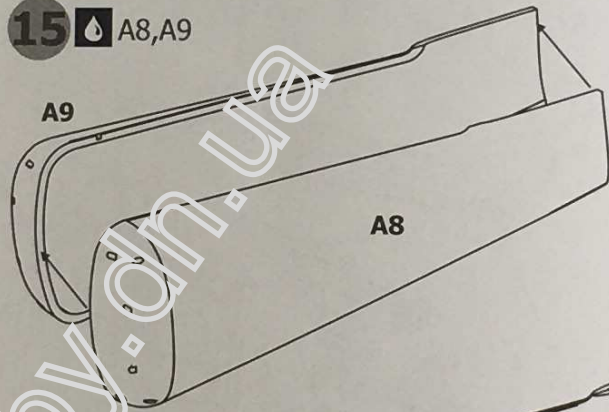

16  Pe1

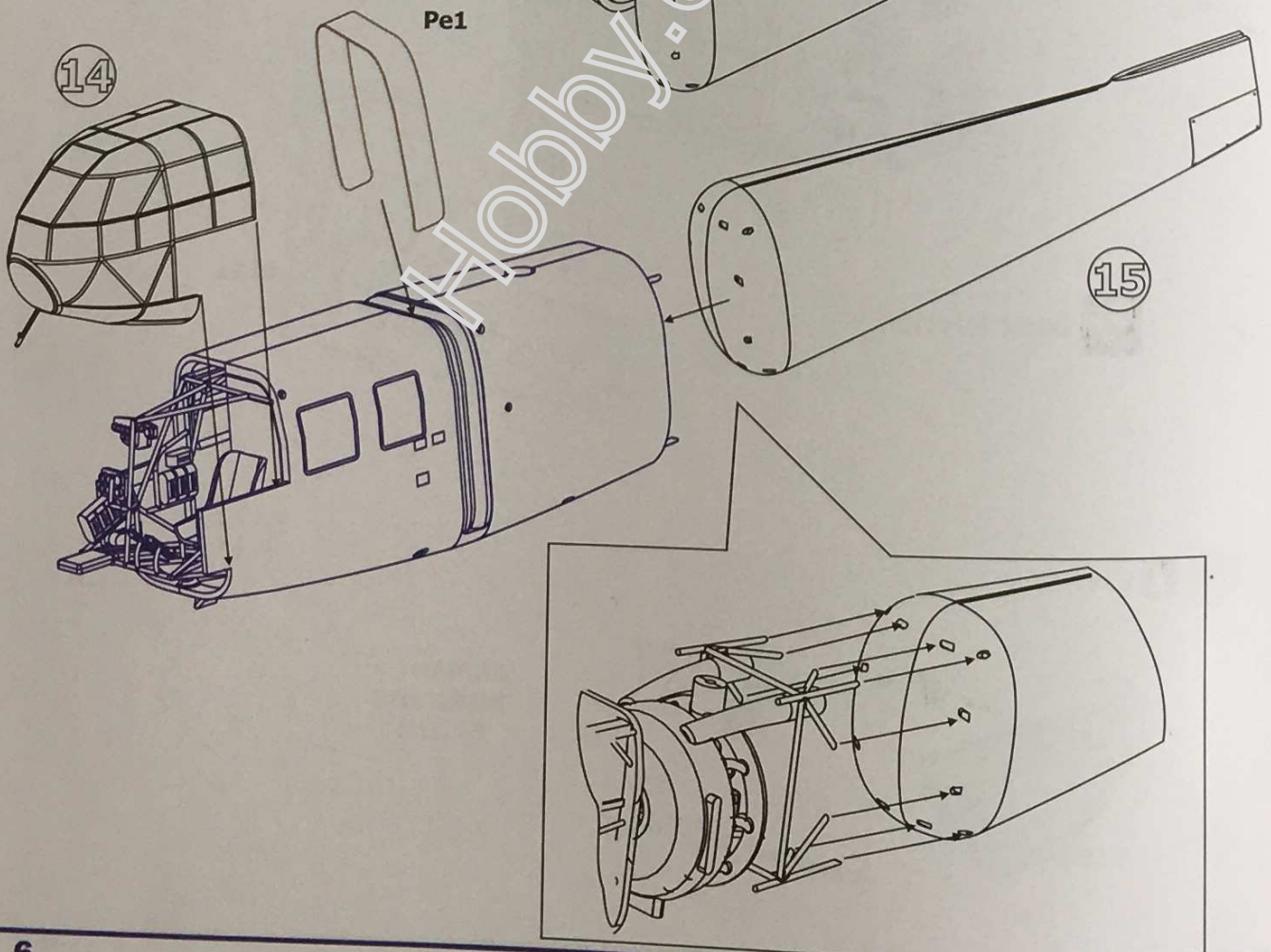

14

15

17 Pe2-5

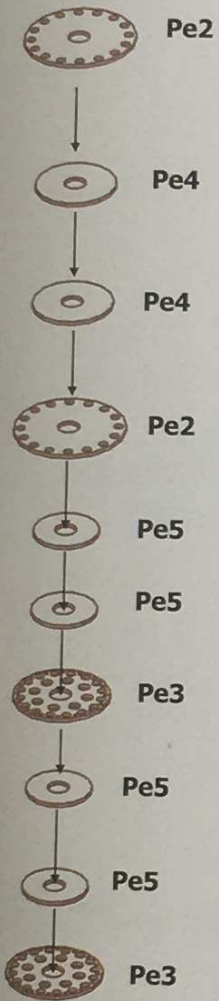

18 F71,F72,F73,F75,F78,F80

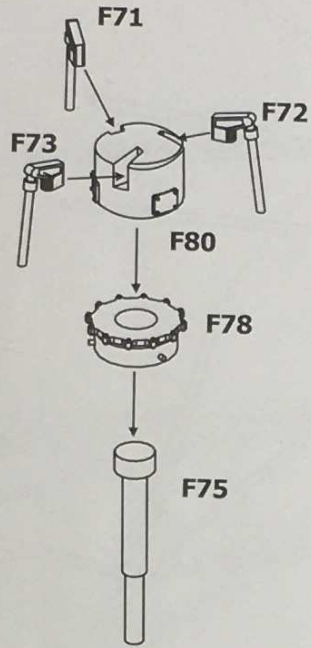

19 E38,E33

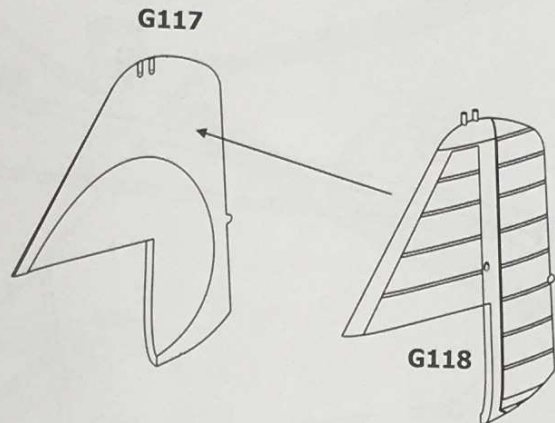

20 E37,E115

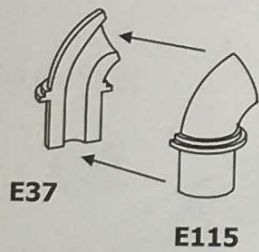

21 A3,D96,D105

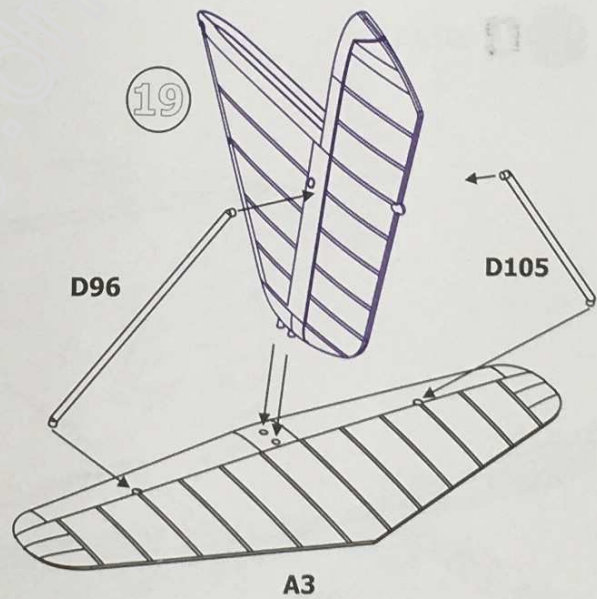

22 C13,D104

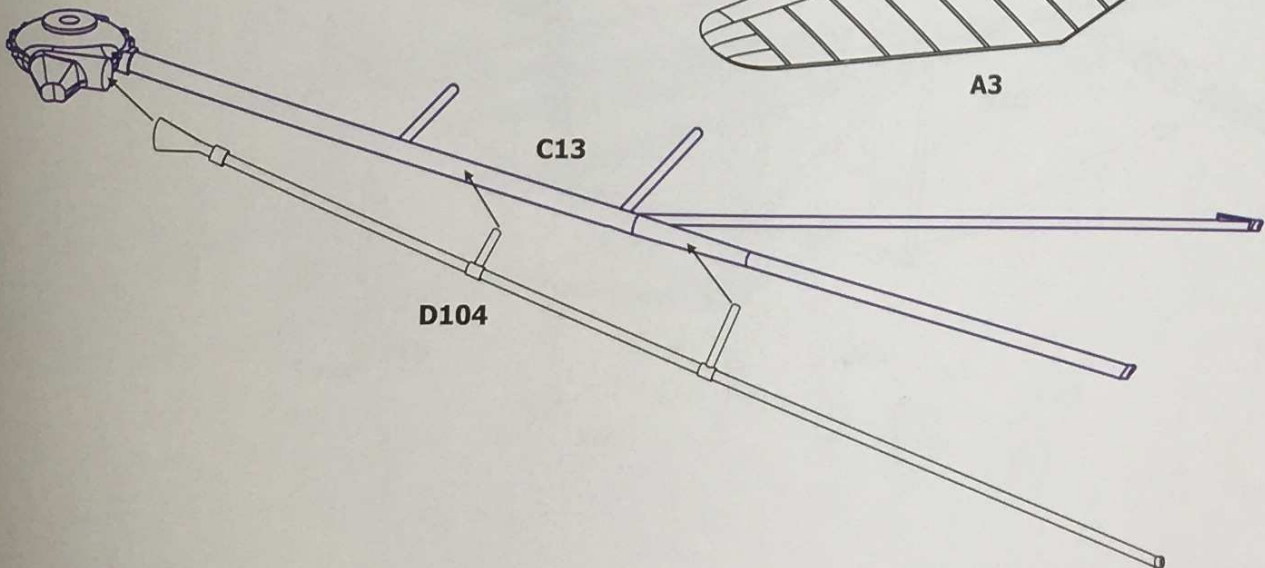

23  C20

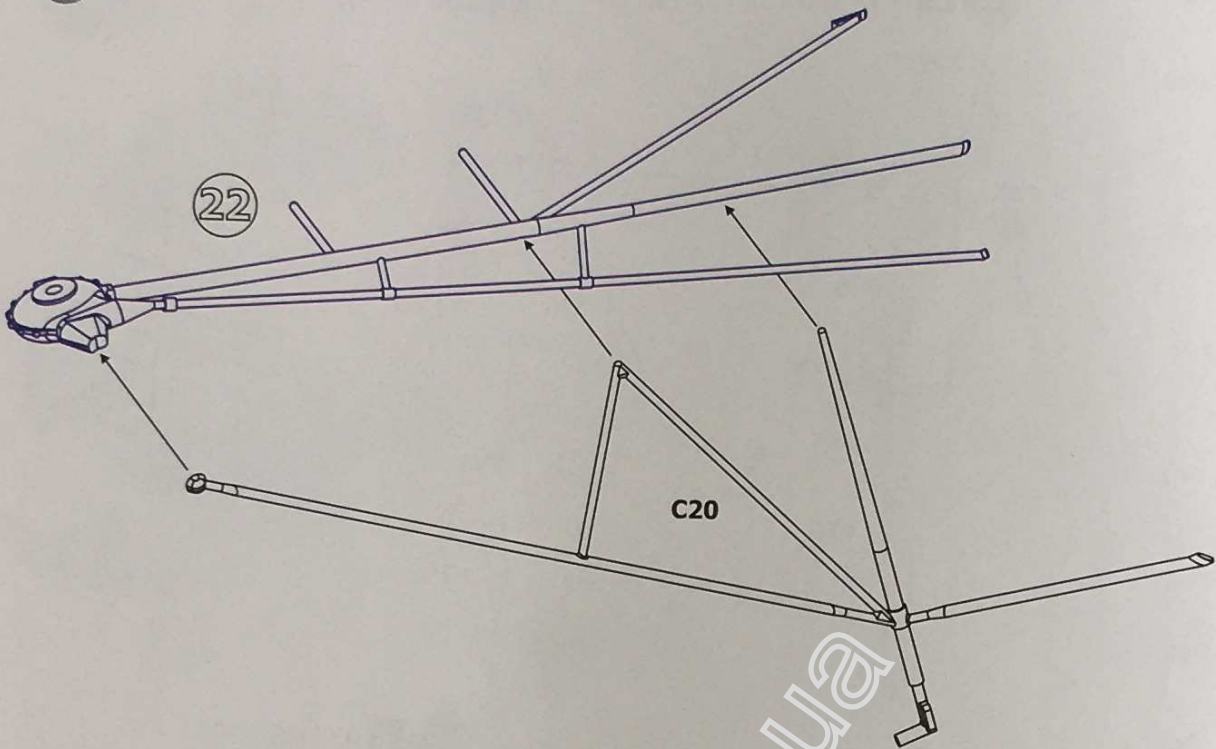

24  D92,C15

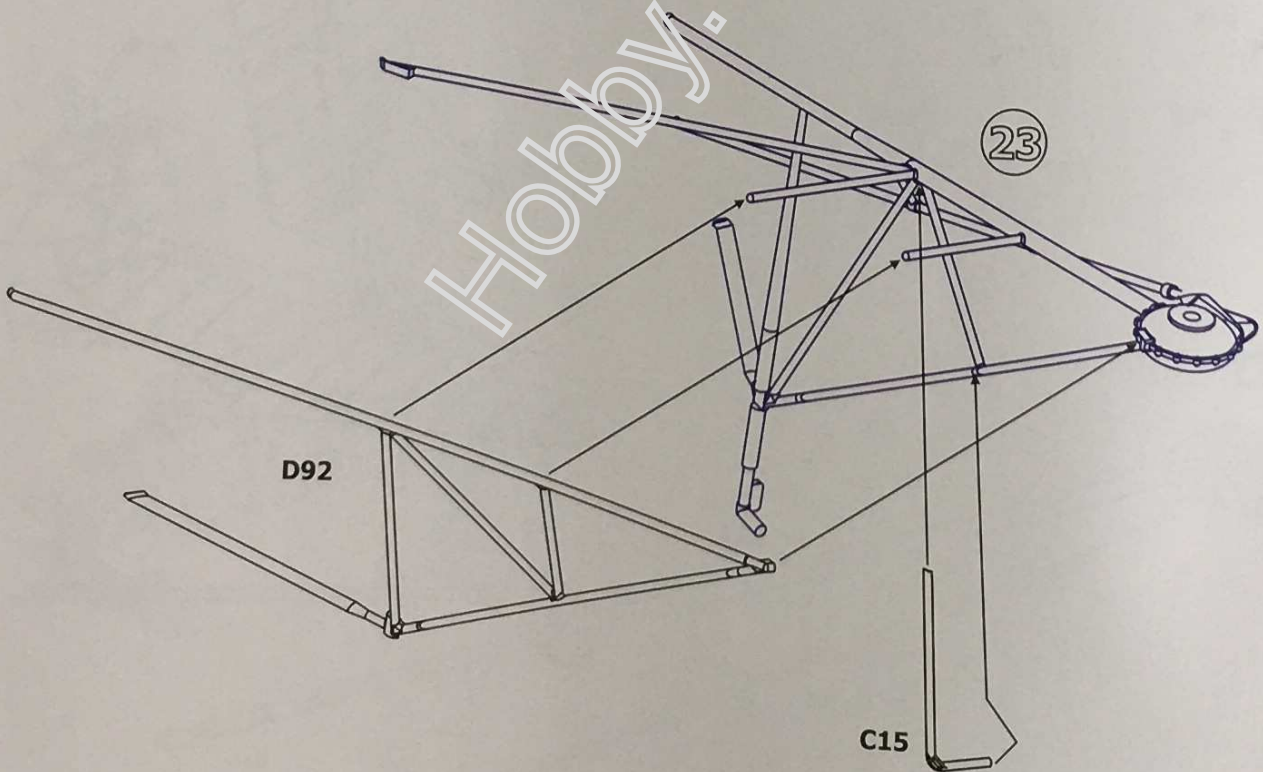

25 E116,F70,F74,F76,F77

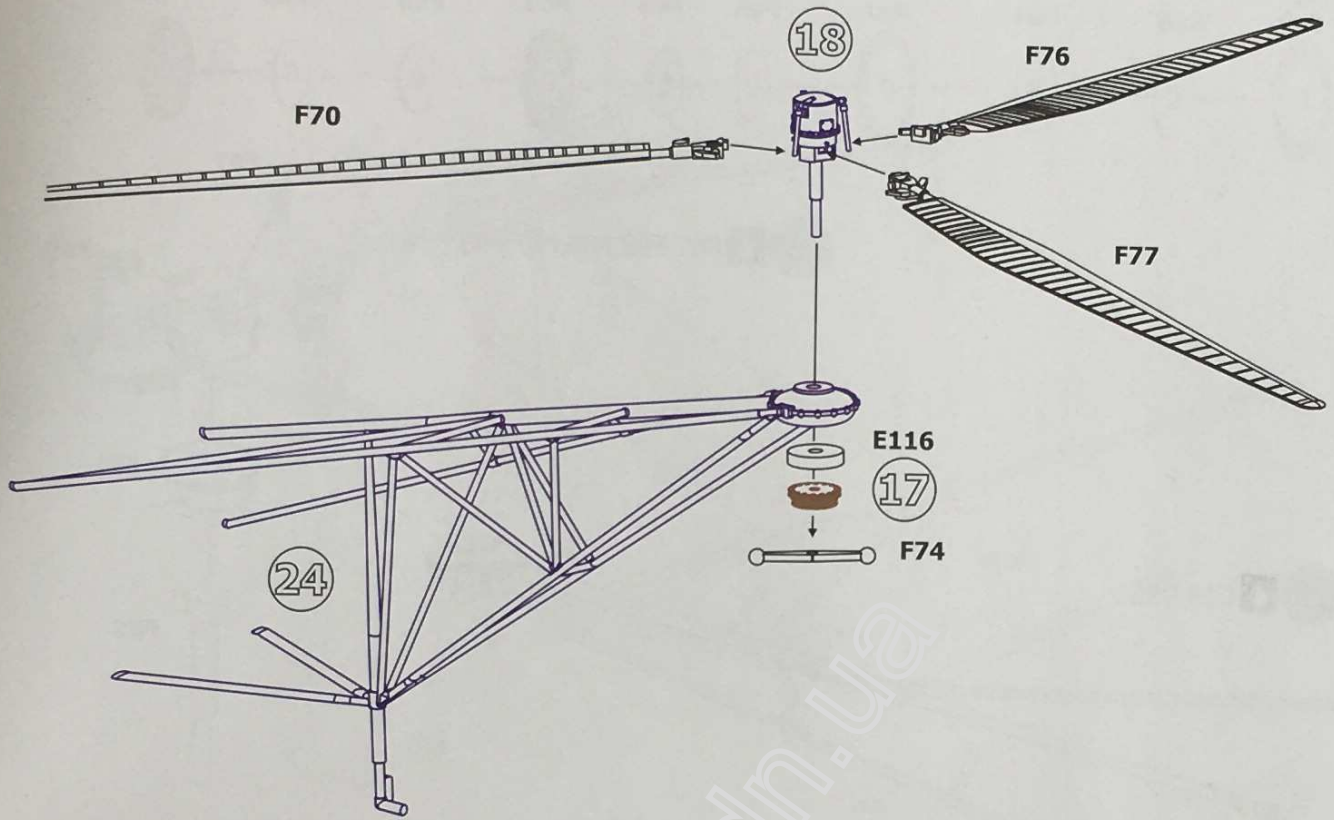

26 A4,C26,E64,E66,D99

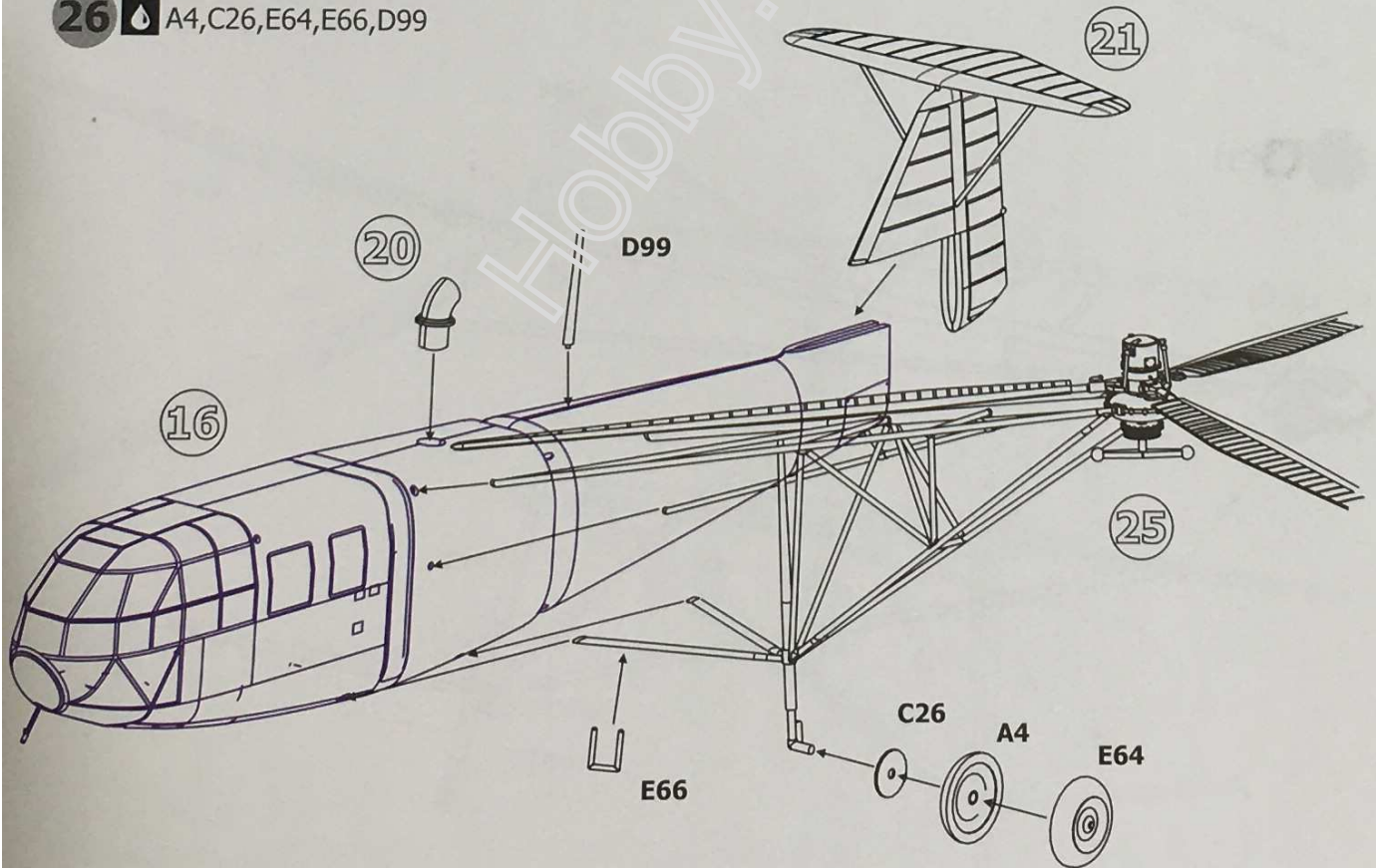

27 Pe2-5

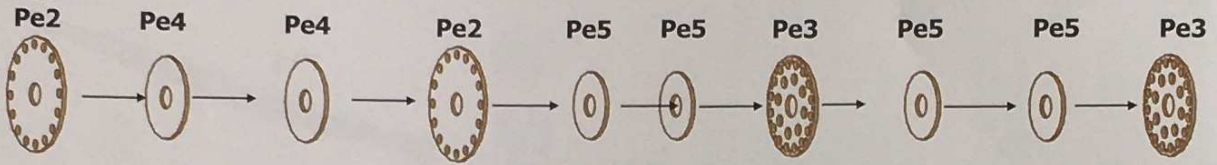

28 F81,F83,F85,F87,F88,F89

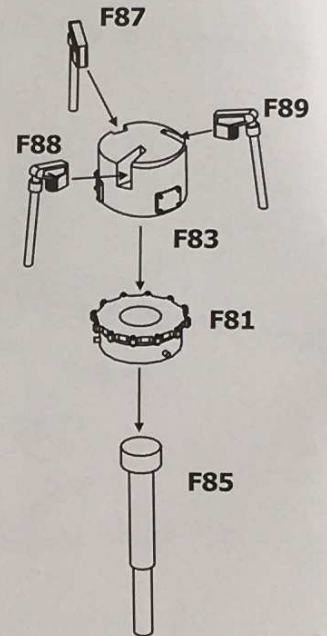

29 C14,D95

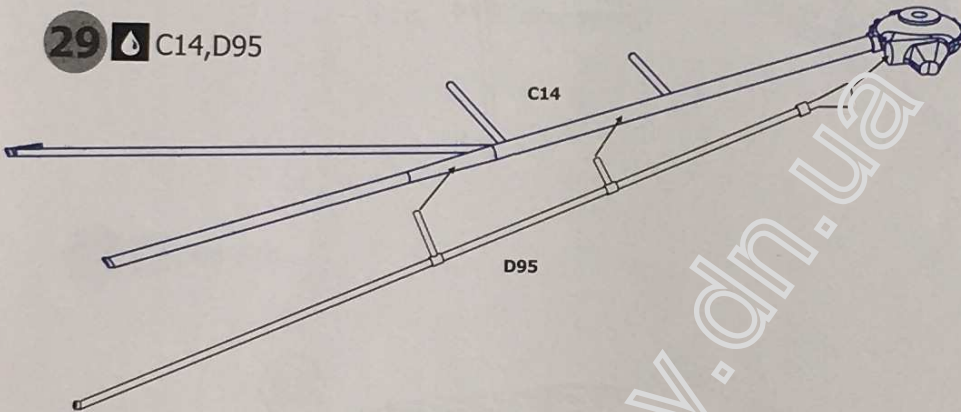

30 C31

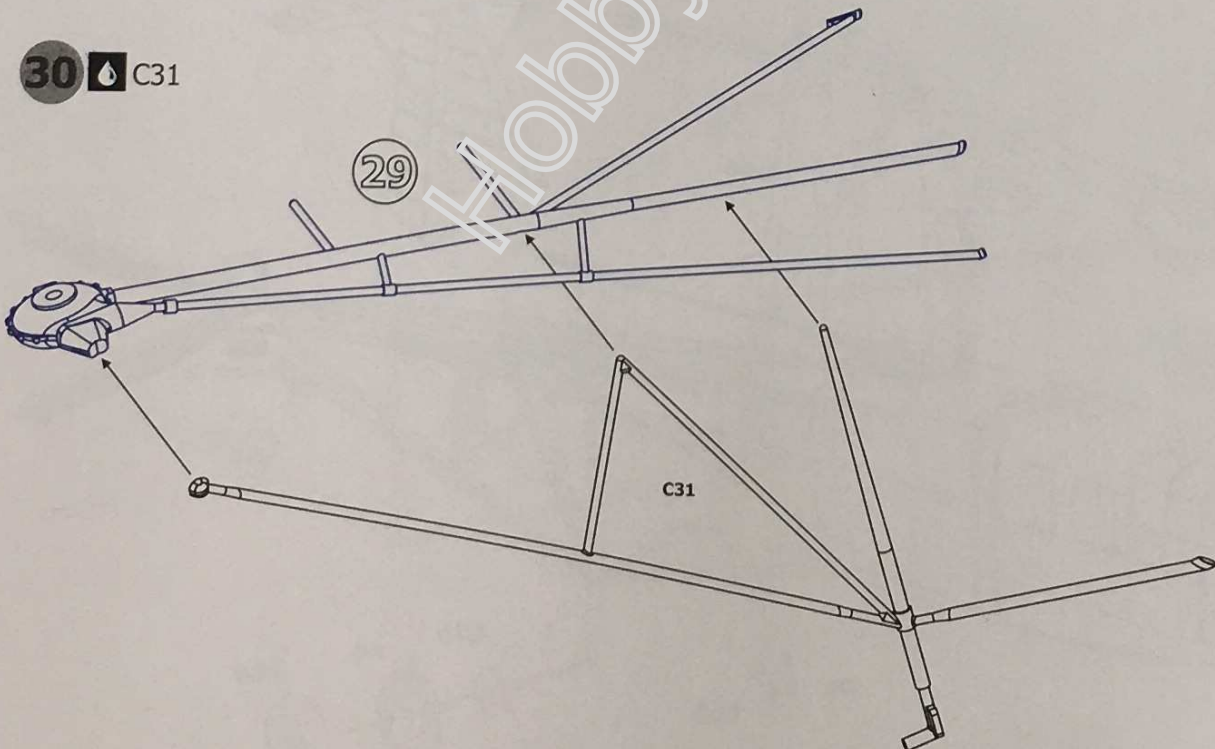

31 C17,D101

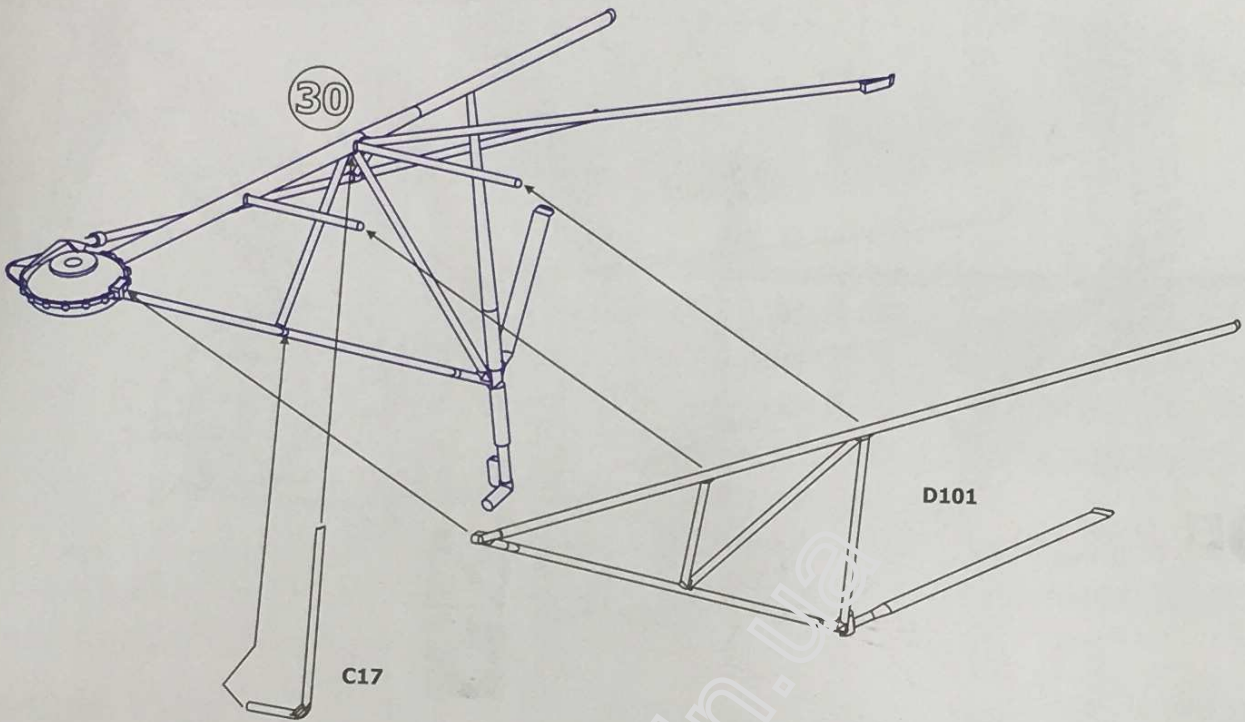

32 F84,F86,F90,F91,E117

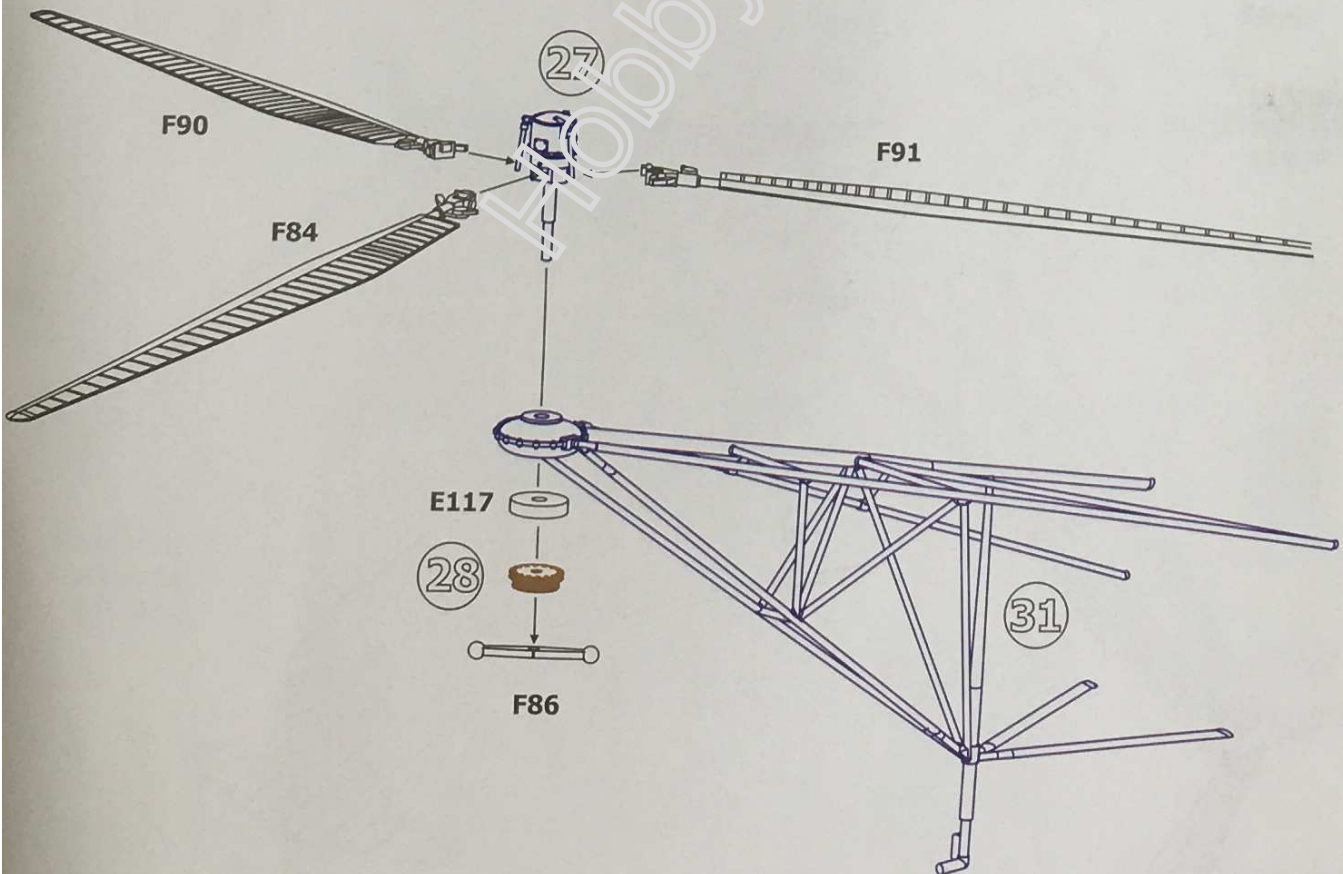

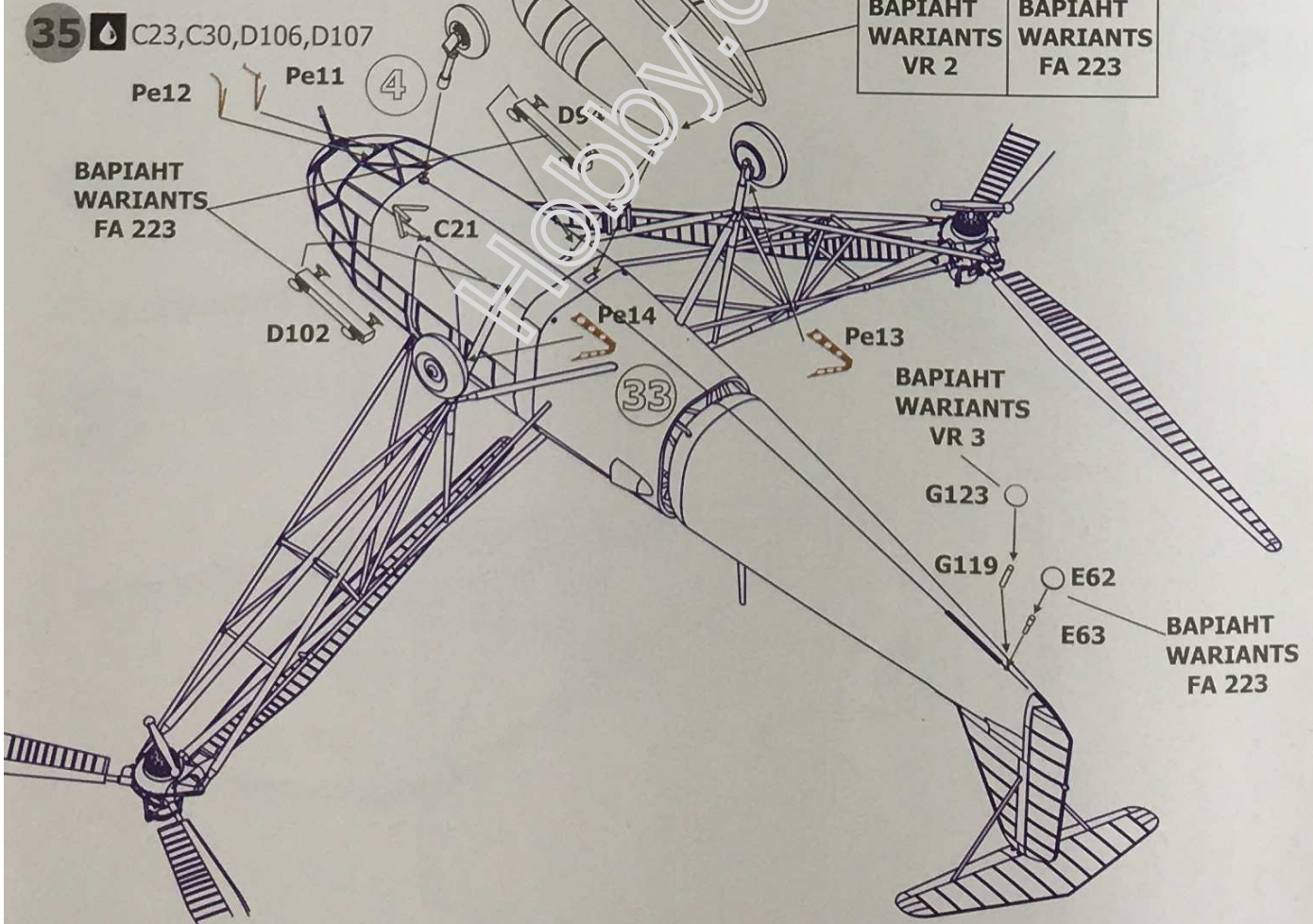
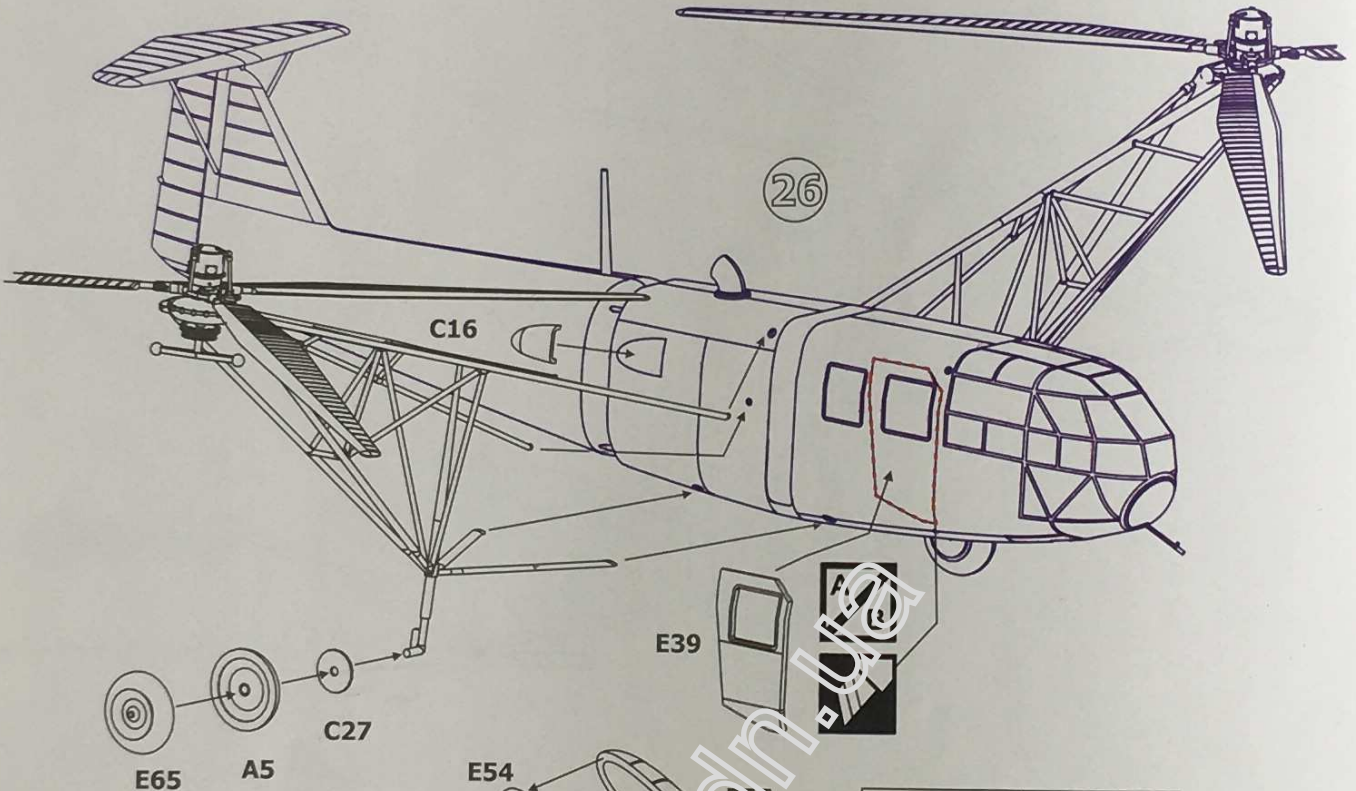

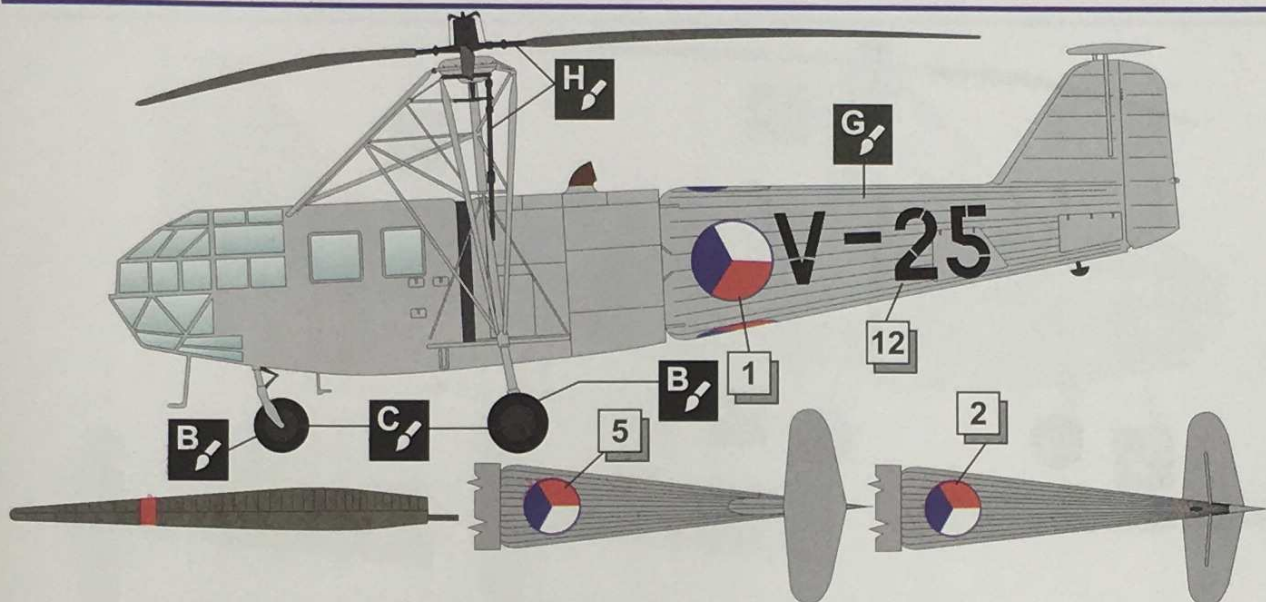

Чехословацький вертоліт VR 1.2, 1948 рік. VR 1,2 hyelicopter. 1948.

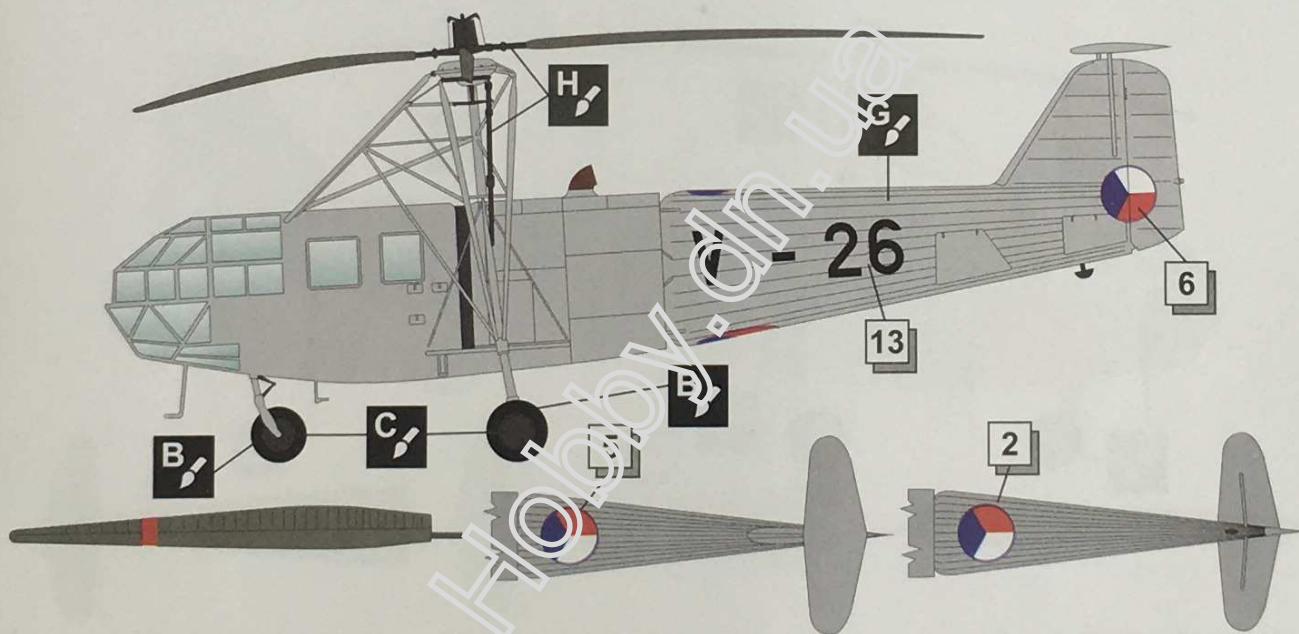

Чехословацький вертоліт VR 3. VR 3 hyelicopter.

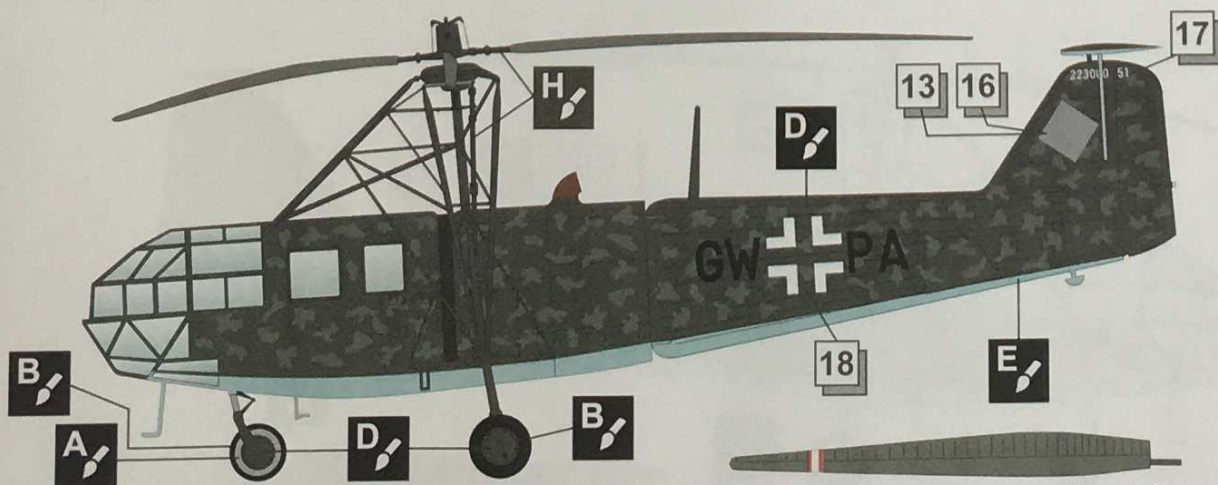

Фа 223ES51 злетів 6 лютого 1945 р. Фа 223 production helicopter had flown at February 6, 1945.

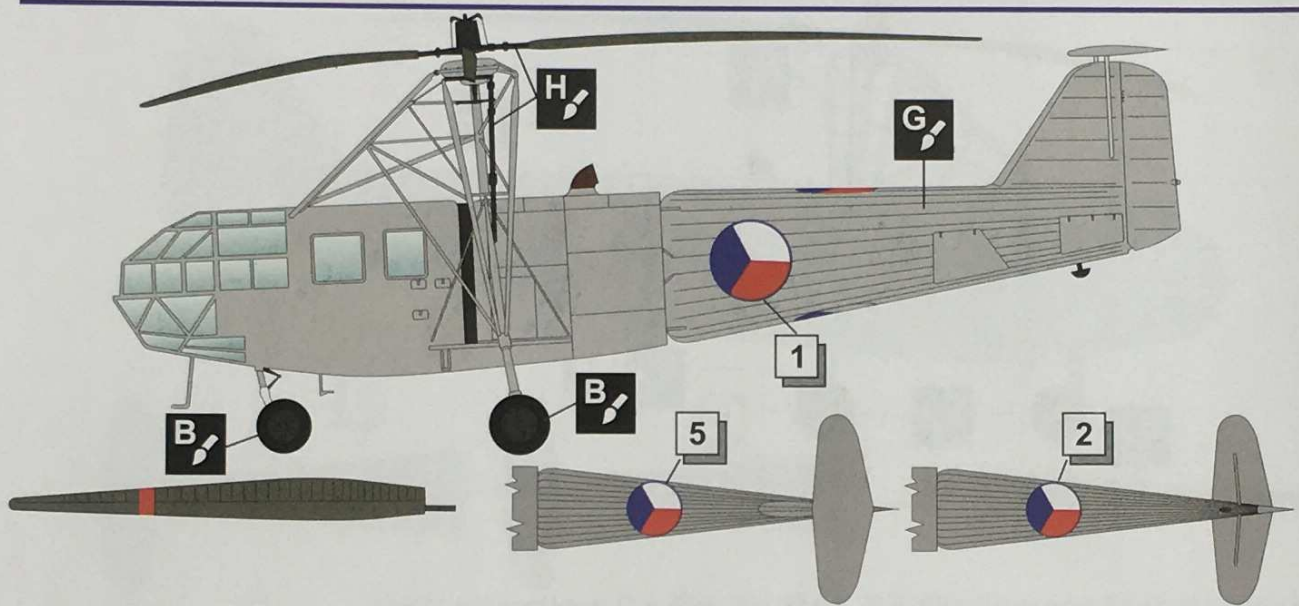

Вертоліт Avia VR-1 .2 піднявся у повітря у 1948 році. VR-1 .2 hyelicopter, 1948.

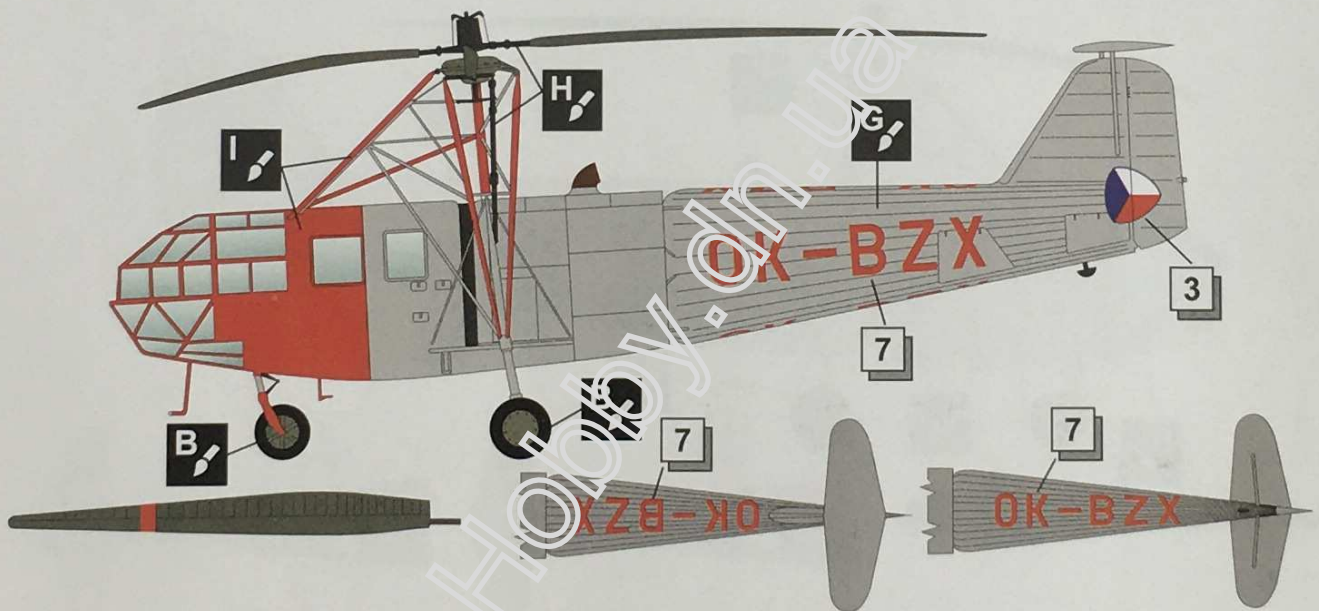

Вертоліт Avia VR-1 .1 піднявся у повітря у 1948 році. Avia VR-1 .1 hyelicopter, 1948.

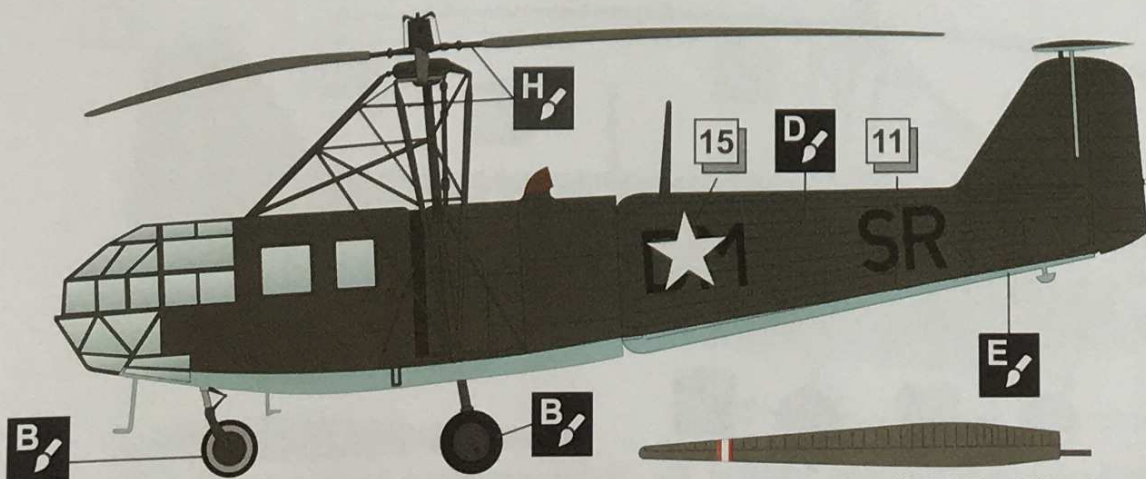

Fa 223E Werk-Nr 00051, побачений після застосування знаків USAAF у Ейррінге, 1945 року
 Fa 223E Werk-Nr 00051 seen after application of USAAF insignia at Ainring, may 1945.

Focke-Achgelis Fa 223