

### Uwaga!

Przed rozpoczęciem pracy dokładnie przeczytaj instrukcję. Zachowaj zasady bezpieczeństwa przy pracy z łatwopalnym klejem i farbami! Trzymaj model z dala od małych dzieci. Nie pozwalaj im brać do ust/nosa części plastikowych lub naciągać na głowę torebek plastikowych!  
**Wsparcie klienta:** W przypadku jakichkolwiek problemów z modelem bez wahania wypełnij formularz zgłoszenia na stronie:

<http://www.armahobby.pl/webpage/wsparcie-faq.html>

### Warning!

Before you start, please read the instructions carefully. Working with flammable glue and/or paint, please follow the safety recommendation of the manufacturers. Keep out of reach of small children! Do not allow them to place plastic parts in their mouths or noses or to pull plastic bags over their heads. **Customer care:** In case of any problems with the model, please do not hesitate to contact us and fill the claim form on our website

<http://www.armahobby.com/webpage/wsparcie-faq.html>

Hawker Hurricane Mk II powstał po doświadczeniach bojowych zebranych w walkach nad Francją, które szybko wykazały główne słabości pierwszej wersji myśliwca. Zespół konstrukcyjny Sydneya Camma postawił sobie za cel poprawę osiągnięć i skuteczności uzbrojenia. 11 czerwca 1940 r. oblatano prototyp wersji Mk II wyposażony w silnik Rolls-Royce Merlin XX z dwustopniową sprężarką. Z tym silnikiem Hurricane osiągał prędkość 342mph (550km/h). Pierwsze seryjne Hurricane Mk IIA weszły do akcji we wrześniu 1940. Drugim etapem modernizacji była poprawa siły ognia poprzez zwiększenie liczby karabinów maszynowych do dwunastu, co skutkowało pojawieniem się wersji Mk IIB. Równolegle pracowano nad dostosowaniem skrzydła do montażu działek 20mm Hispano-Suiza HS.404. Tak uzbrojona wersja, oznaczona Mk IIC, pojawiła się w jednostkach (242, 3 i 257 Dywizjon RAF) w marcu 1941 r. i bez większych zmian była produkowana do lipca 1944 r. Łącznie powstało 4711 egzemplarzy maszyn wersji Mk IIC służących na niemal wszystkich frontach Drugiej Wojny Światowej. Samolot, skonstruowany jako myśliwiec przechwytyjący, przystosowano z czasem do roli intrudera, nocnego myśliwca (powstała też wersja wyposażona w radar), myśliwca pokładowego, czy samolotu szturmowego i lekkiego bombowca. W tej ostatniej roli wyróżniał w jednostkach pierwszoliniowych najdłużej. Wersja Mk IIC stała się też punktem wyjścia do powstania przeciwpancernej wersji Mk IID, wyposażonej w dwie 40mm armatki Vickers S, oraz Mk IV - wyspecjalizowanej wersji szturmowej, mogącej przenosić bomby lub pociski rakietowe. Poza europejskim teatrem działań używano wersji tropikalnej, wyposażonej w charakterystyczny filtr przeciwpylewy. Piloci Polskich Sił Powietrznych spotkali się z Hurricane Mk IIC już jesienią 1941 r. odbywając staze bojowe w 87. Dywizjonie. W roku 1943 pojedyncze egzemplarze trafiły do 318. Dywizjonu Myśliwsko-Rozpoznawczego, a w kwietniu 1944 r. cały polski 309. Dywizjon został wyposażony w ten typ i operował z lotnisk w Szkocji pełniąc służbę patrolową.

**Podziękowania:** Grzegorz Cieliszak

The Hawker Hurricane Mk II was developed after the first combat experience gained in the battles over France, which quickly showed the main weaknesses of the first version of the fighter. Sydney Camm's design team set itself to improve the plane's performance and armament effectiveness. On June 11, 1940, the prototype of the Mk II version was flown, equipped with a Rolls-Royce Merlin XX engine with a two-stage compressor. With this engine, the Hurricane reached 342 mph (550 km/h). The first production Hurricane Mk IIA went into action in September 1940. The second stage of modernisation was to improve firepower by increasing the number of machine guns to twelve, resulting in the appearance of the Mk IIB version. At the same time, work was carried out on adapting the wing to the installation of 20mm Hispano-Suiza HS.404 cannons. Cannon-armed version, marked Mk IIC, appeared in units (242, 3 and 257 Squadrons RAF) in March 1941 and was produced without major changes until July 1944. A total of 4,711 Mk IIC machines were produced, serving on almost all fronts during the Second World War. The aircraft, designed as an interceptor, was adapted over time to the role of an intruder, a night fighter (a version equipped with radar was also created), a carrier-based fighter, an attack aircraft and a light bomber. He lasted the longest in the first-line units in the latter role. The Mk IIC version also became the starting point for the Mk IID anti-tank version, equipped with two 40mm Vickers S cannons and the Mk IV - a specialised assault version that could carry bombs or rockets.

A tropicalised version was used outside the European theatre of operations, equipped with a distinctive dust filter. The pilots of the Polish Air Force met the Hurricane Mk IIC as early as in the autumn of 1941 during exchange postings in the No. 87 Squadron. In 1943, single examples were sent to the No. 318 Fighter-Reconnaissance Squadron, and in April 1944, the entire Polish No. 309 Squadron was equipped with this type and operated from airfields in Scotland on patrol duty.

**Acknowledgement:** Grzegorz Cieliszak

### Kalkomanie/Decals

### Części przezroczyste/Clear parts

### Części plastikowe/Plastic parts

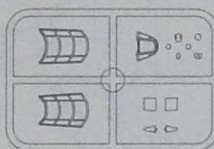
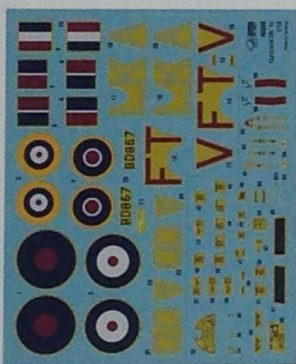

### Maski/Masks

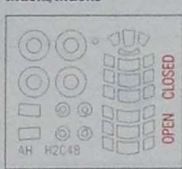

### Wydruki 3D/3D Print

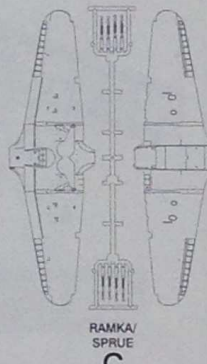
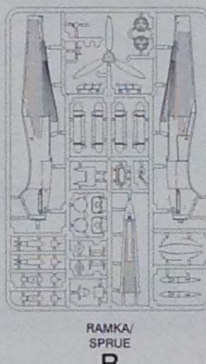
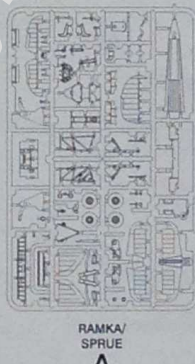
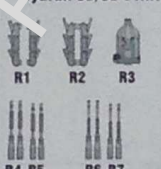

Kolory farb/ Paint colours	Hataka	AK RC	Mission Models	AMMO	Humbrol	Vallejo	Tamiya	Kolory farb/ Paint colours	Hataka	AK RC	Mission Models	AMMO	Humbrol	Vallejo	Tamiya
<b>A</b> Matt Silver FS 37178	HTK-A003/ C003	RC210	MMM-008	195	11	71.063	X-11	<b>G</b> Dark Green FS34092	HTK-A016/ C016	RC286	MMP-058	915	116	71.324	XF-81
<b>B</b> Matt Black FS37038	HTK-A100/ C100	RC001	MMP-047	046	33	71.057	XF-1	<b>H</b> Ocean Grey FS36176	HTK-A032/ C032	RC288	MMP-093	245	106	71.273	XF-82
<b>C</b> Interior Grey Green FS34226	HTK-A025/ C025	RC283	MMP-079	219	78	71.305	XF-71	<b>I</b> Medium Sea Grey FS38270	HTK-A034/ C034	RC289	MMP-094	243	165	71.307	XF-83
<b>D</b> Gun Metal HTK-A106/ C106	RC015	MMM-010	045	53	71.073	X-10	<b>J</b> Sky Type S FS34583	HTK-A026/ C026	RC290	MMP-080	0243	90	71.302	XF-21	
<b>E</b> Insignia Red FS11136	HTK-A219/ C219	RC006	MMP-101	049*	153	71.102*	X-7*	<b>M1</b> MIXED GREY 1 - 10 części/parts of MSG (I) and 1 część/part of Black (B)							
<b>F</b> Insignia Yellow FS13538	HTK-A066/ C066	RC008	MMP-007	048	154	71.002	XF-3	<b>M2</b> MIXED GREY 2 - 8 części/parts of MSG (I) and 1 część/part of Black (B)							

\*Kolor zbliżony/approximate colour

Więcej informacji na temat budowy tego modelu: <http://armahobbynews.pl/blog/tag/nr40006/>

More advice on building this kit: <http://armahobbynews.pl/en/blog/tag/nr40006-en/>

Manufacturer Arma Hobby S.C  
 Ostrobramska 101/200, 04-041 Warszawa, Poland  
[www.armahobby.pl](http://www.armahobby.pl) [www.armahobby.com](http://www.armahobby.com)  
 kontakt1@armahobby.pl  
 © 2023 Arma Hobby S.C all rights reserved



montaż symetryczny/  
symmetrical assembly



zegnij/  
bend



usuń/  
remove



obróć/  
rotate



kalkomania/  
decals



nawierć/  
drill



zwin/  
roll



wybór/  
option

DLA PODWIESZENIA ZBIORNIKÓW ZAPASOWYCH (A) LUB WYRZUTNIKÓW BOMBOWYCH (B) NAWIERĆ ODPOWIEDNIE OTWORY OD WEWNĄTRZ. **NIE UŻYWAJ BOMB DLA MAŁOWAN PUDEŁKOWYCH.** MOŻESZ UŻYĆ ZBIORNIKÓW DODATKOWYCH TYLKO DLA MAŁOWANIA 2/ FOR AUXILIARY TANKS (A) OR BOMBS RACKS (B) DRILL APPROPRIATE HOLES FROM INSIDE. **NONE OF THE BOX SCHEMES USE THE BOMBS.** AUXILIARY TANKS ONLY FOR PAINTING OPTION 2

**A**

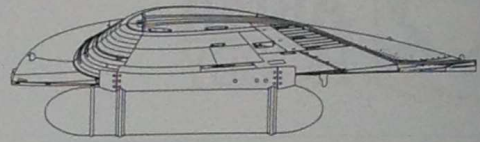

**B**

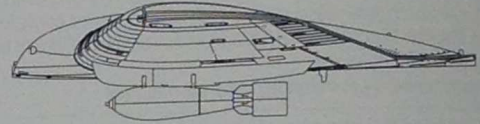

A - ZBIORNIKI/ A - AUXILIARY TANKS

B - BOMBY/ B - BOMBS

C1

**1**

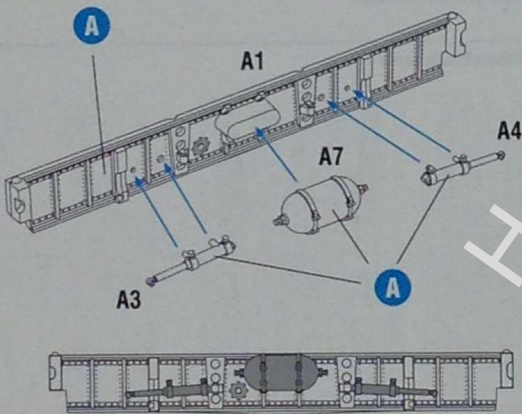

**2**

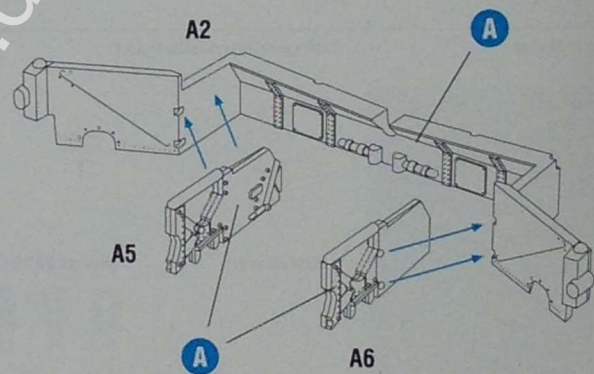

**3**

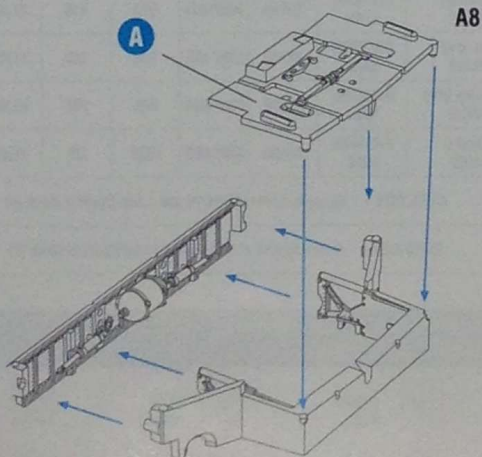

**4**

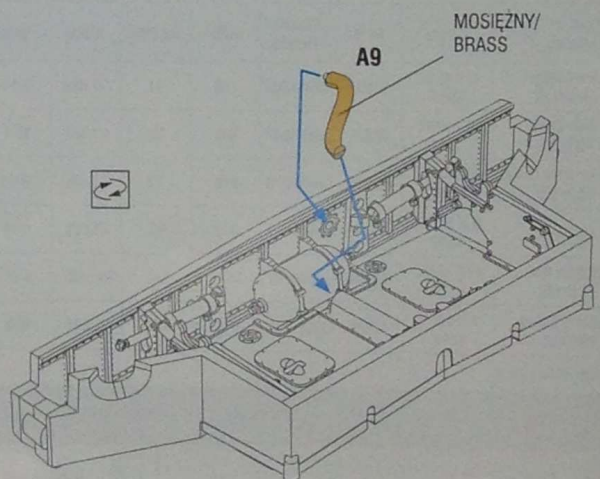

MOSIĘZNY/  
BRASS

5

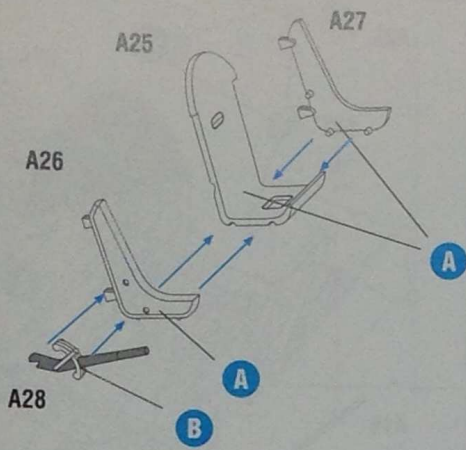

6

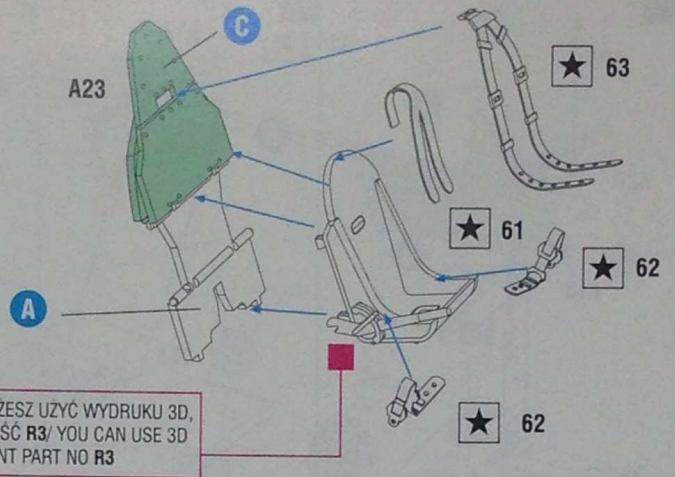

7

DLA MAŁOWANIA 1, 2 PRZESUN OTWÓR DO POZYCJI ZAZNACZONEJ CZERWONYM KOLOREM. STARY OTWÓR (KOLOR NIEBIESKI) ZASLEP / FOR PAINTING OPTIONS 1, 2 MAKE NEW HOLE IN THE NEW POSITION (COLOR RED) THE OLD ONE (COLOR BLUE) FILL IN/REMOVE

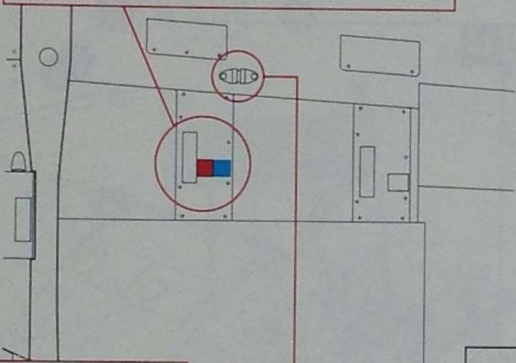

DLA MAŁOWANIA 3 USUN UCHWYTY ZBIORNIKÓW PODWIESZANYCH / FOR PAINTING OPTIONS 3 REMOVE DROP TANK MOUNTS

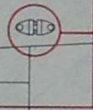

8

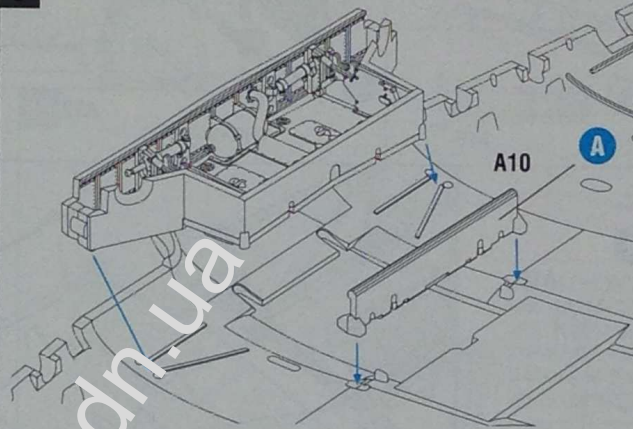

DLA LEPSZEGO DOPASOWANIA REFLEKTORÓW USUN ZAZNACZONE FRAGMENTY LISTWY WZMACNIAJĄCEJ PO WEWNĘTRZNEJ STRONIE SKRZYDŁA (C2) / FOR BETTER FIT REMOVE RED MARKED PART OF THE STRINGERS FROM INNER SIDE OF THE WING (C2)

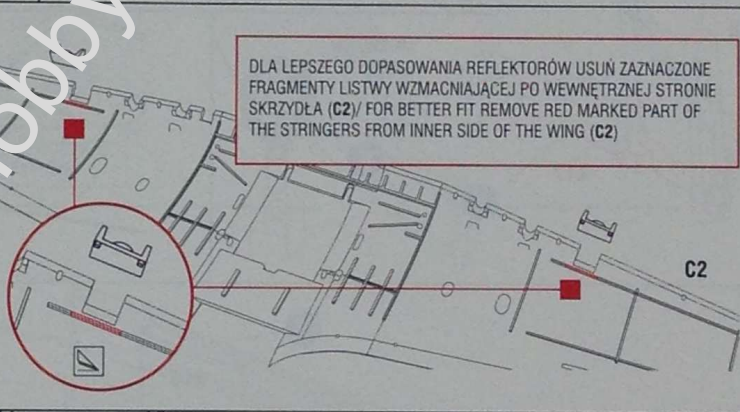

9

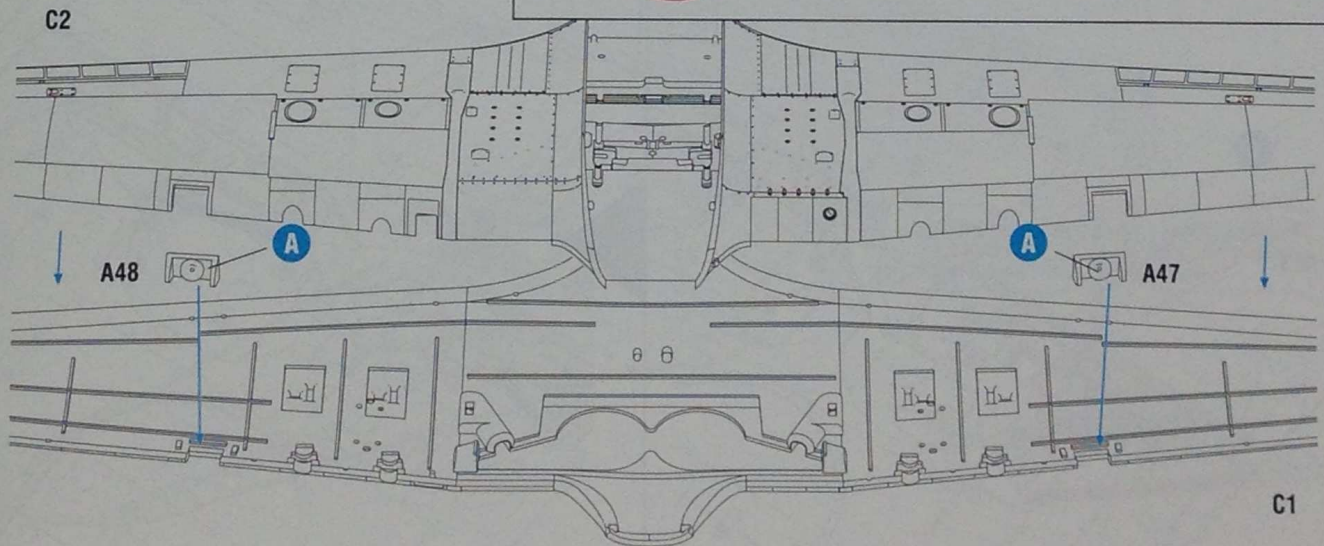

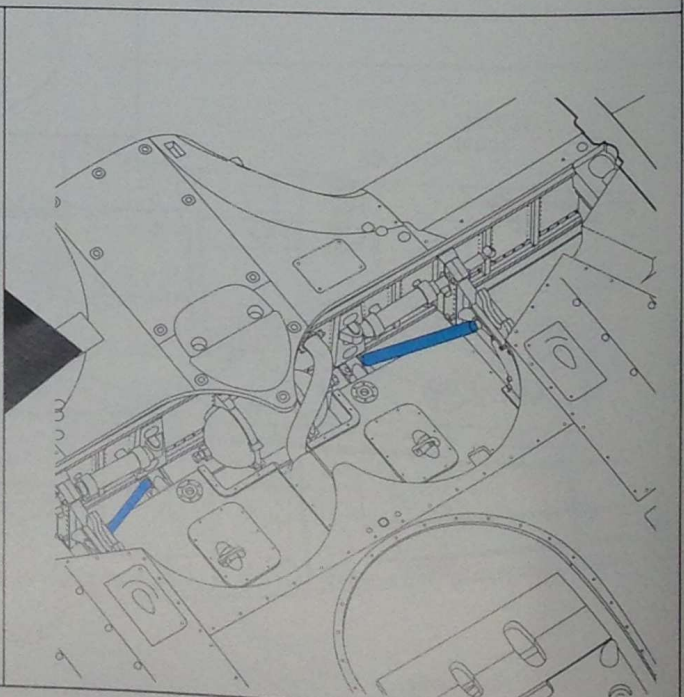
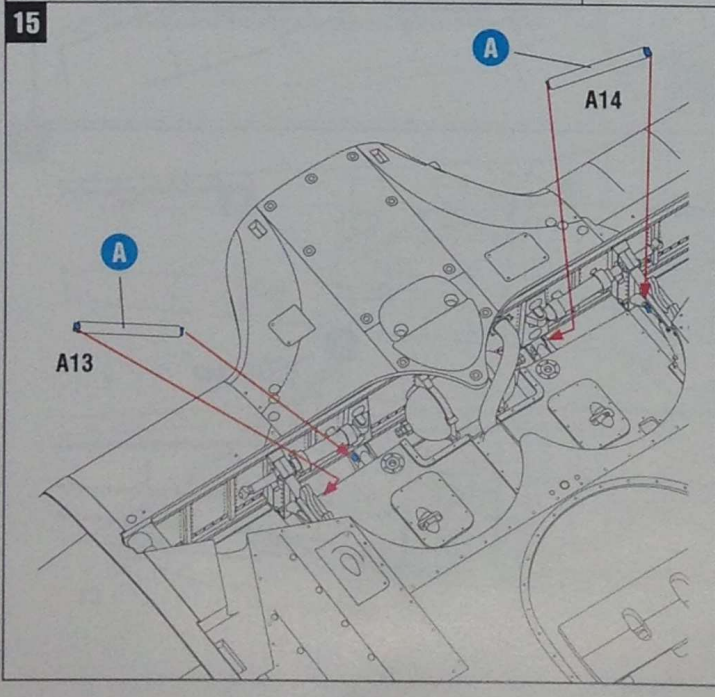
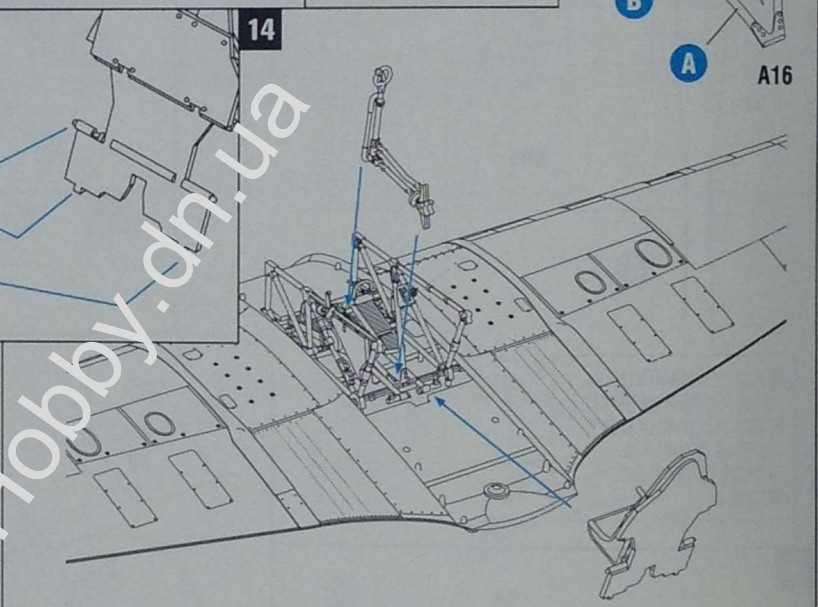
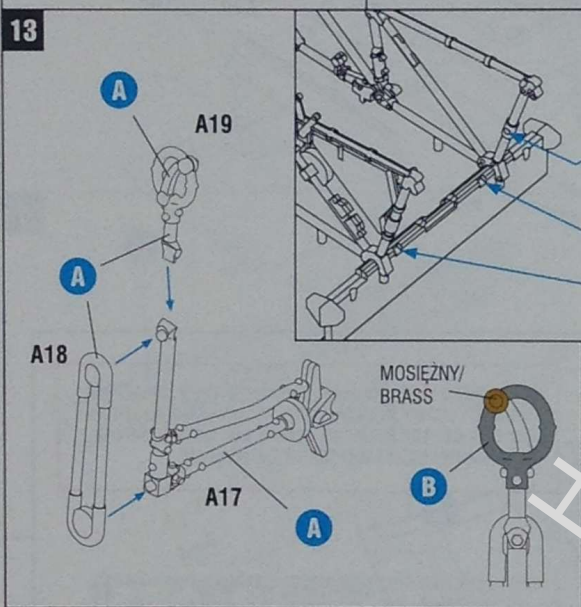
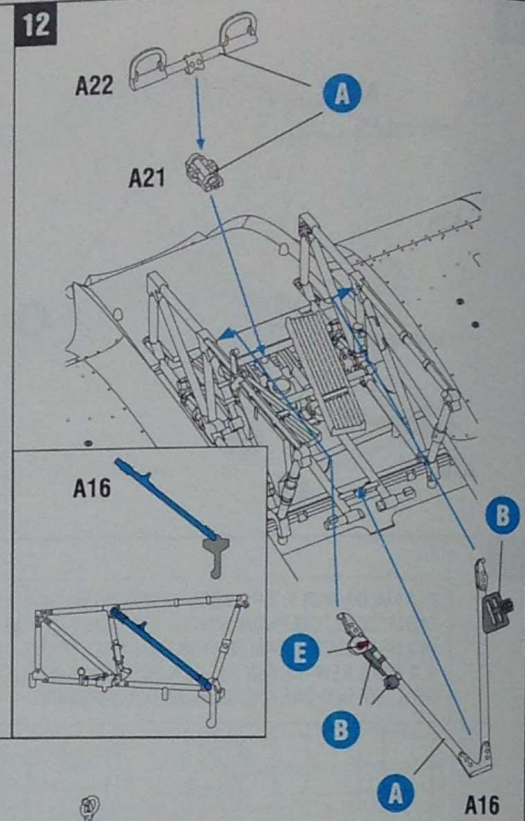
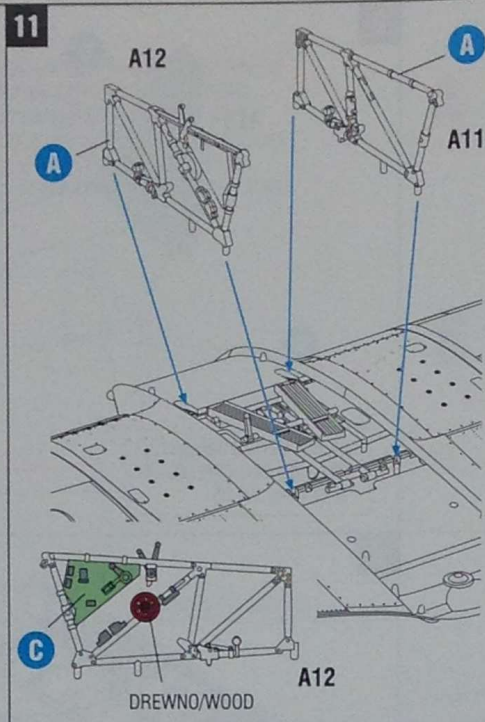
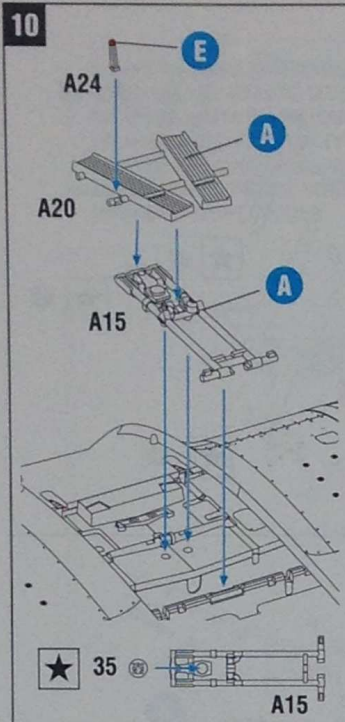

16

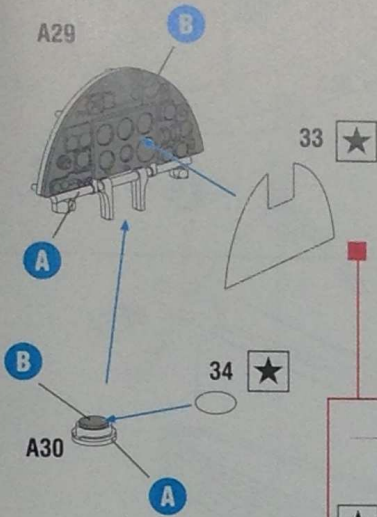

17

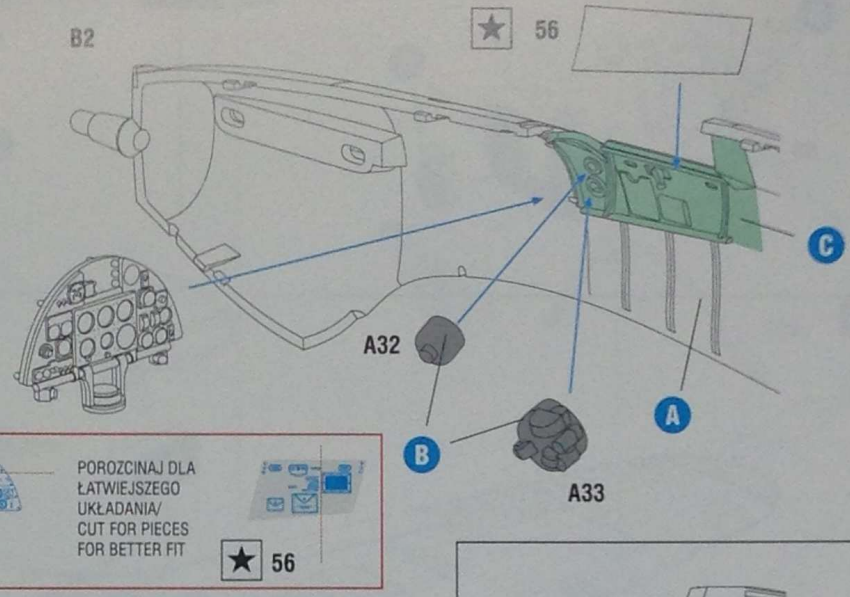

★ 33

PORÓZCINAJ DLA ŁATWIEJSZEGO UKŁADANIA/  
CUT FOR PIECES FOR BETTER FIT

★ 56

18

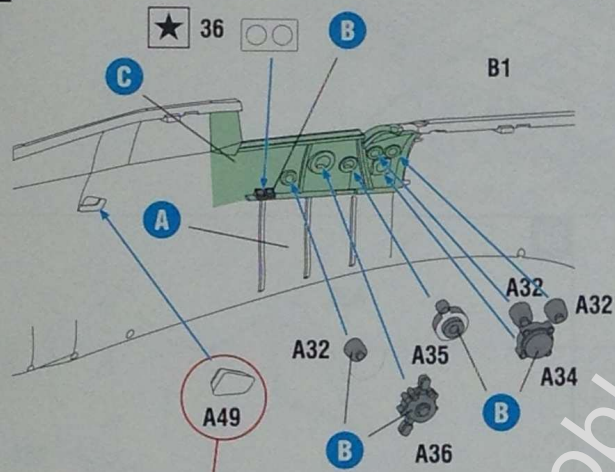

NIE WKLEJAJ CZĘŚCI A49 JEŚLI PLANUJESZ UŻYĆ CZĘŚCI A50 (STOPIEN W POZYCJI OPUSZCZONEJ)/  
DO NOT USE PART A49 IF YOU WANT TO MOUNT PART A50 (FOOT STEP IN THE LOW POSITION)

19

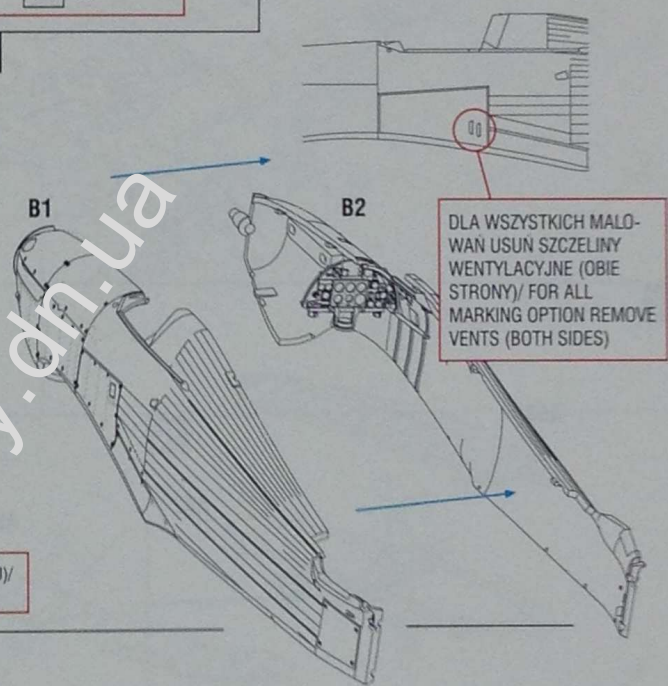

DLA WSZYSTKICH MALOWAN USUN SZCZELINY WENTYLACYJNE (OBIE STRONY)/ FOR ALL MARKING OPTION REMOVE VENTS (BOTH SIDES)

20

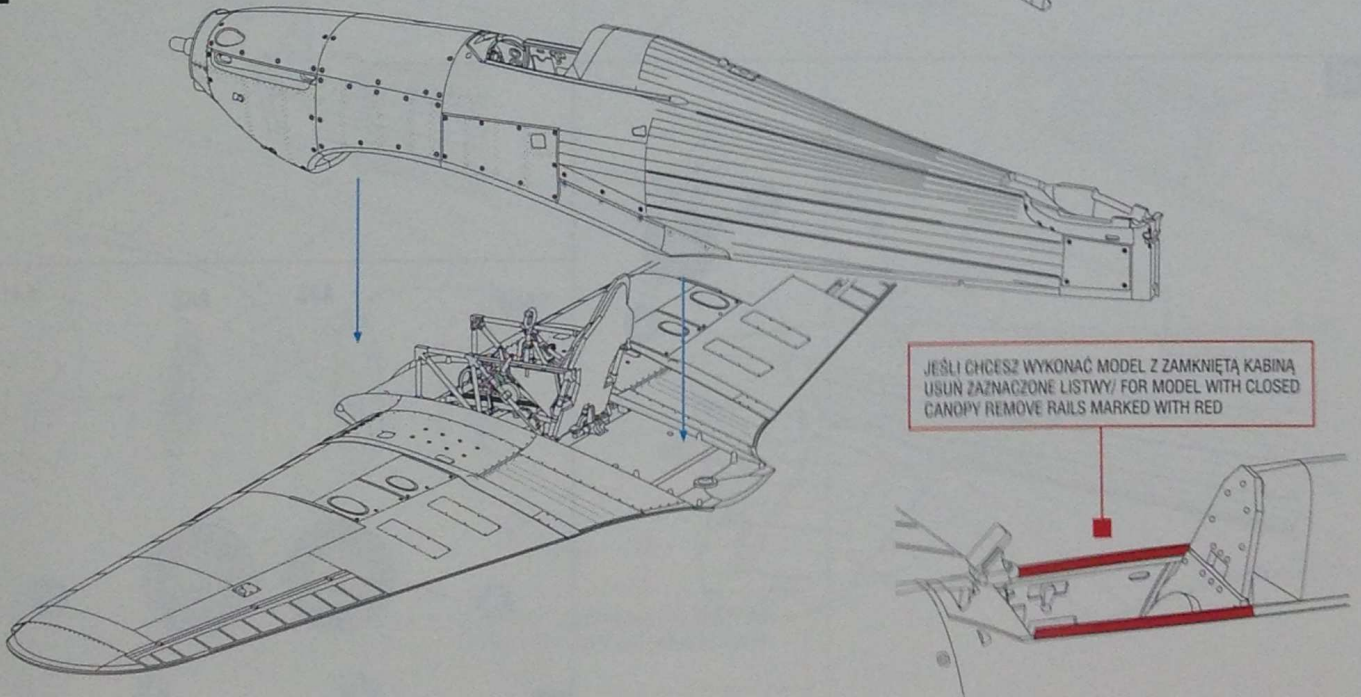

JEŚLI CHCESZ WYKONAĆ MODEL Z ZAMKNIĘTĄ KABINĄ  
USUN ZAZNACZONE LISTWY/ FOR MODEL WITH CLOSED CANOPY REMOVE RAILS MARKED WITH RED

21 22

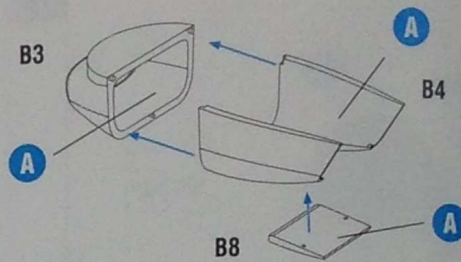
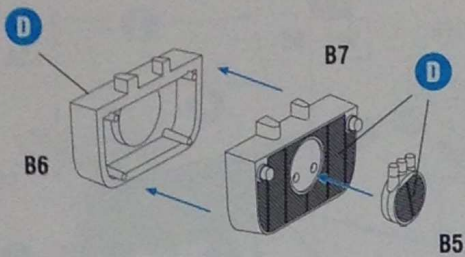

23

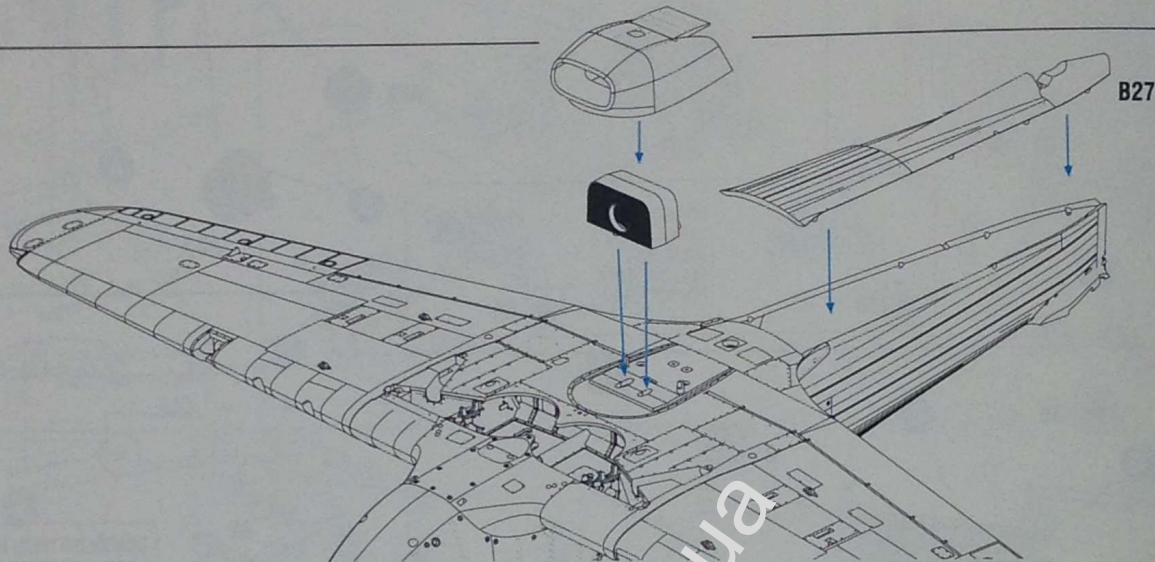

24

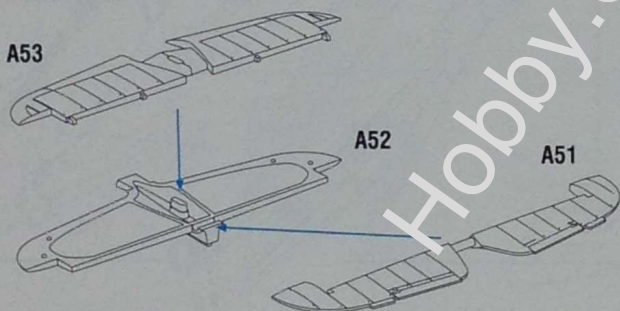

25

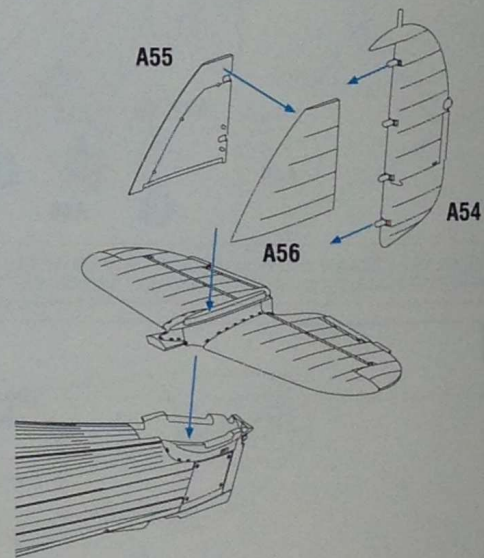

26

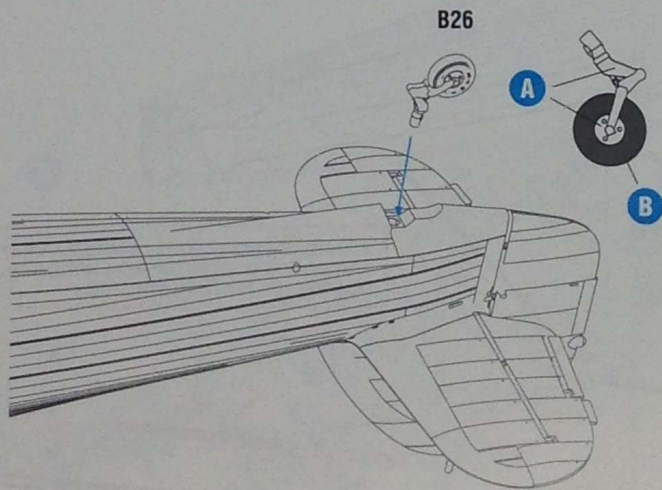

27

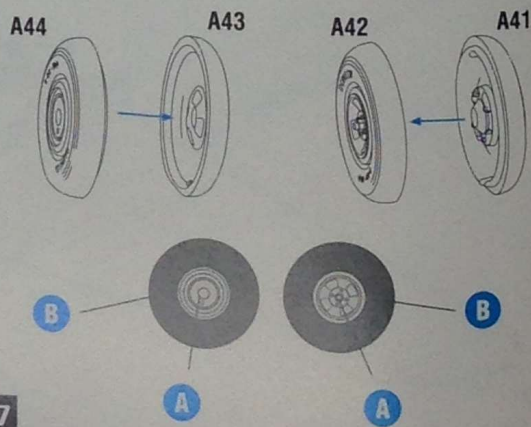

28

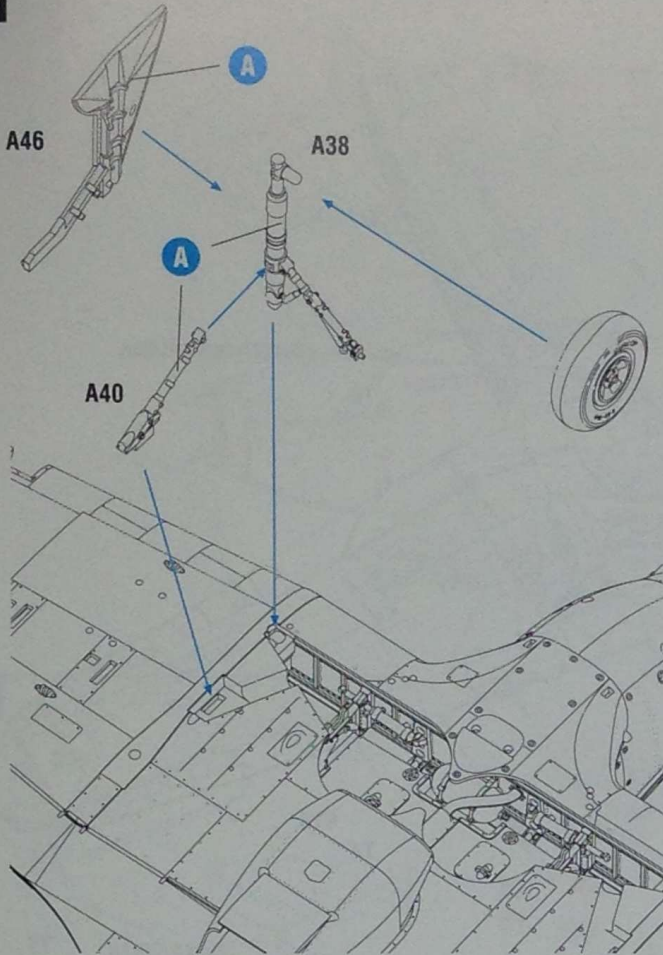

29

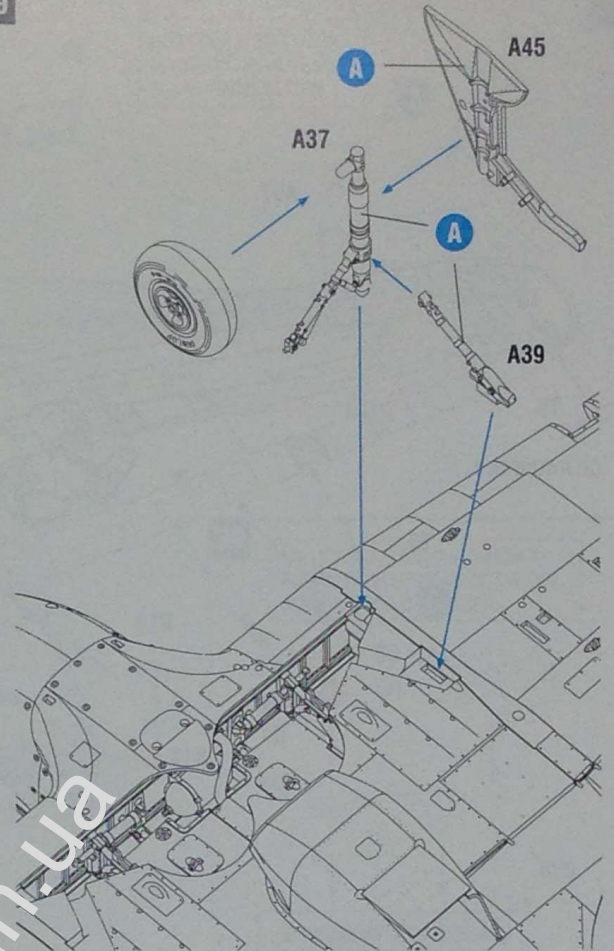

30

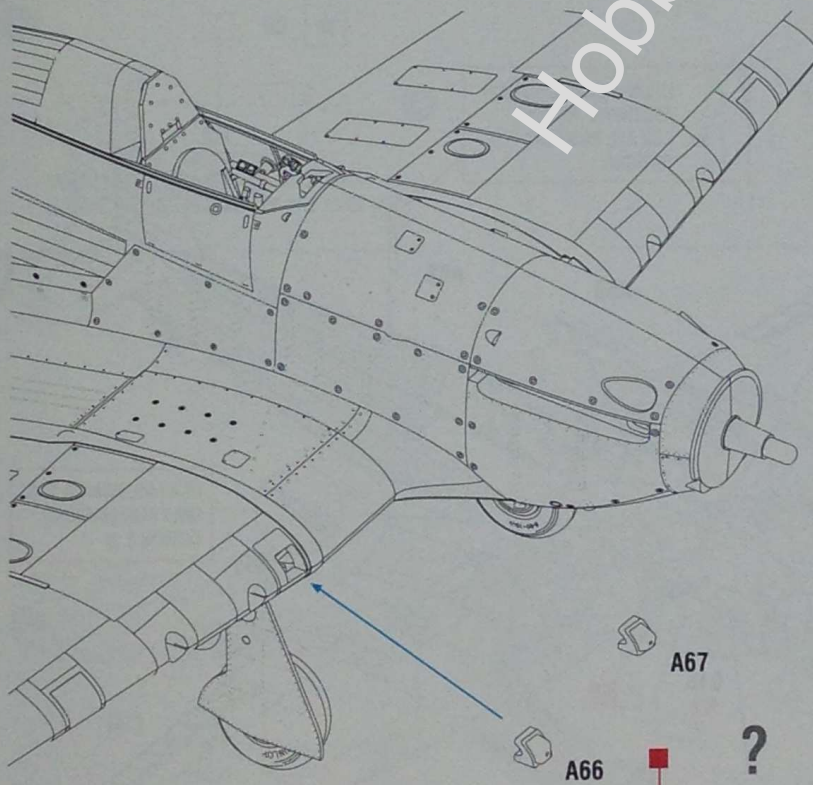

31

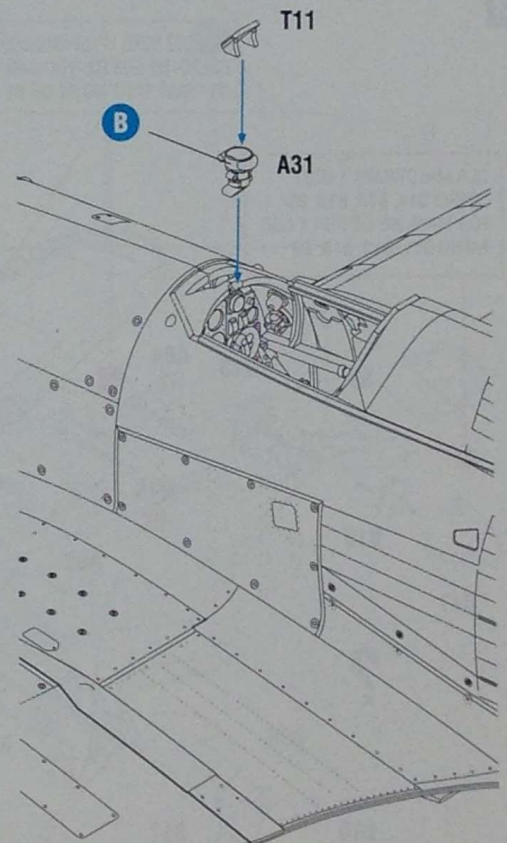

DLA MAŁOWANIA 3 WKLEJ CZĘŚĆ NR A66 I ZESZLIFUJ NA GŁADKO DO POWIERZCHNI SKRZYDŁA.  
DLA MAŁOWANIA 1, 2 UŻYJ CZĘŚCI A67/ FOR MARKING OPTION 3 USE PART NO. A66 AND FLUSH  
WITH WING SURFACE, FOR MARKING OPTION 1, 2 USE PART NO A67

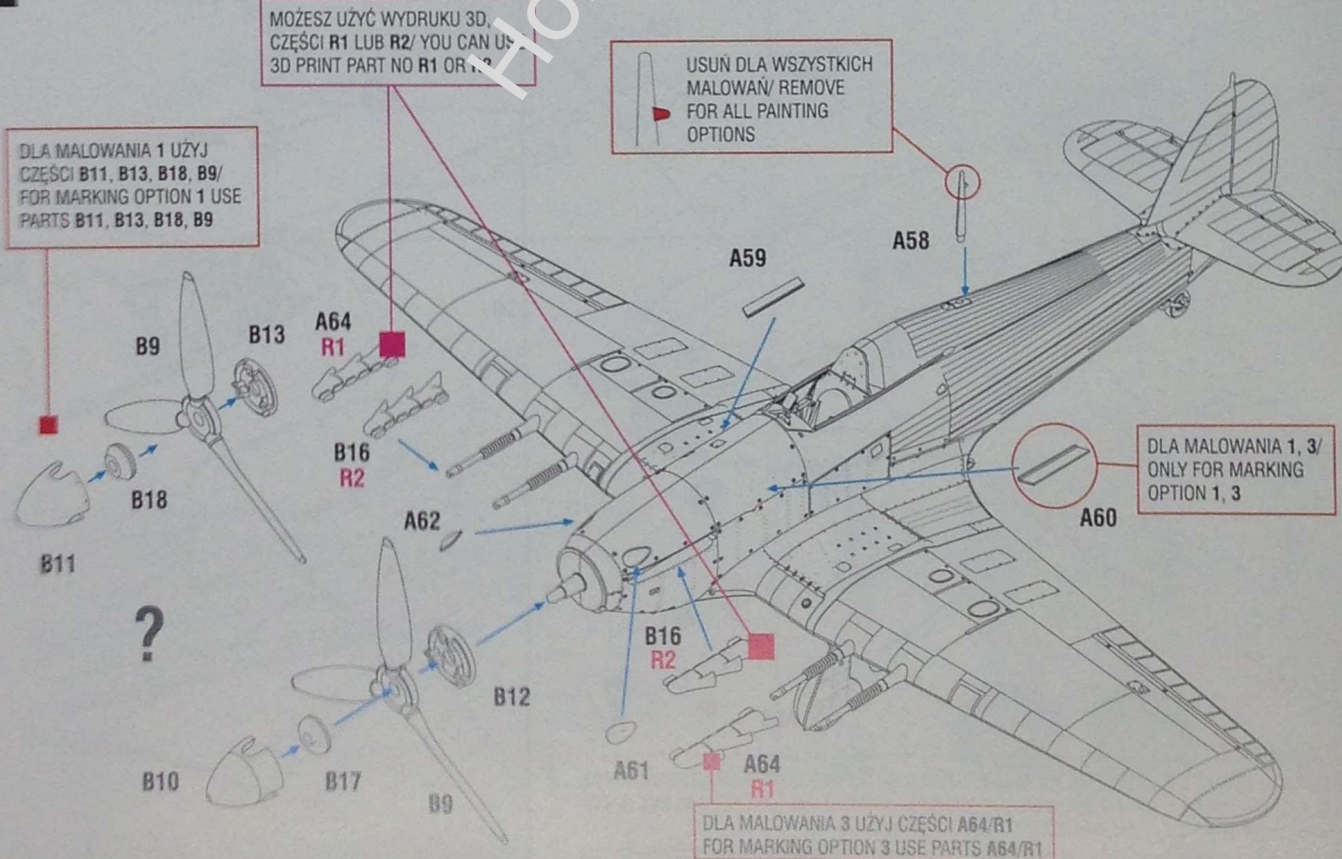
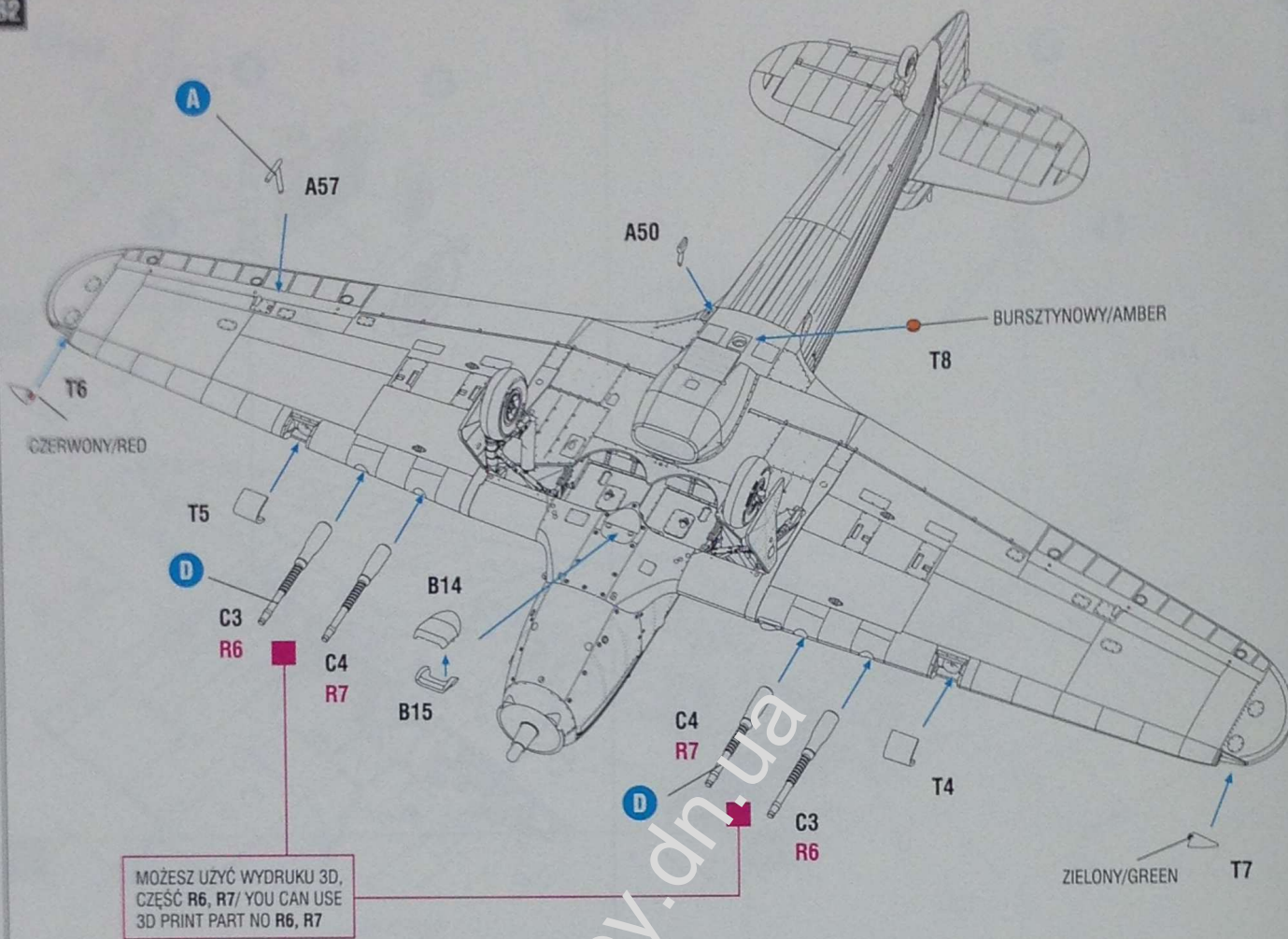



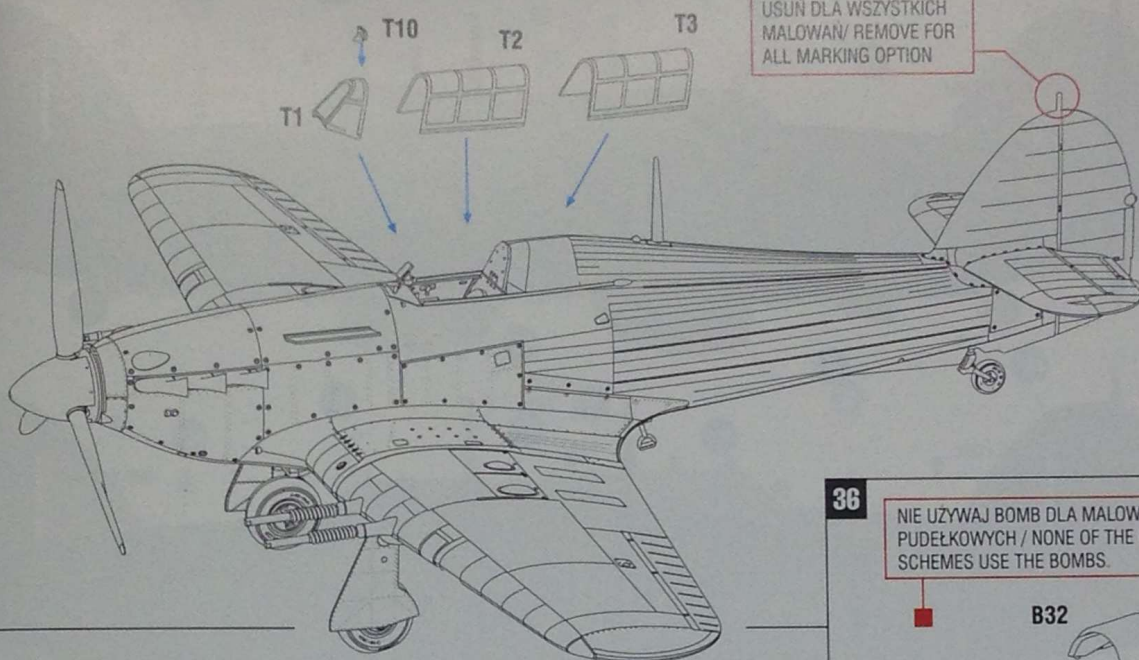

35

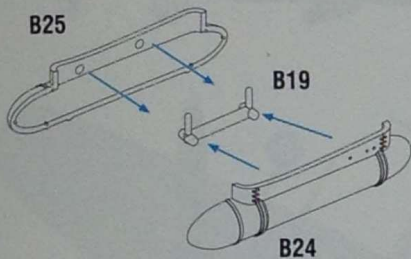

MOŻESZ UŻYĆ ZBIORNIKÓW DLA MALOWANIA 2/ YOU CAN USE THE DROP TANKS FOR PAINTING OPTION 2

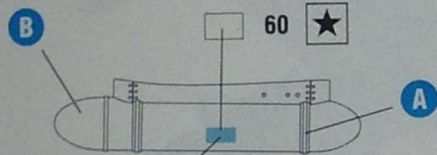

ZAWSZE PO LEWEJ STRONIE ZBIORNIKA/ ALWAYS AT THE LEFT SIDE OF THE TANK

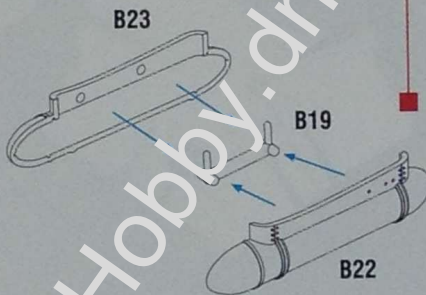

36

NIE UZYWAJ BOMB DLA MALOWAN PUDEŁKOWYCH / NONE OF THE BOX SCHEMES USE THE BOMBS.

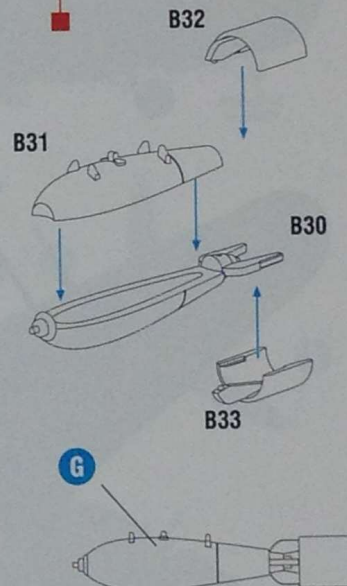

37

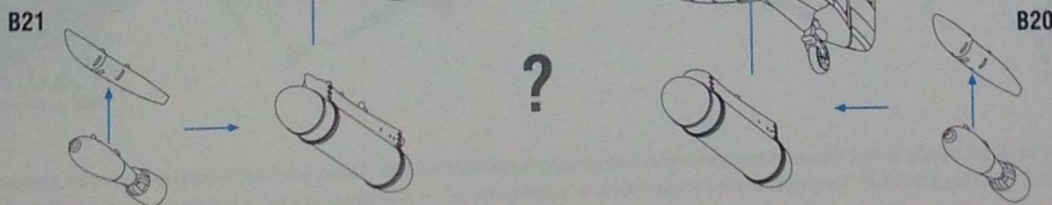
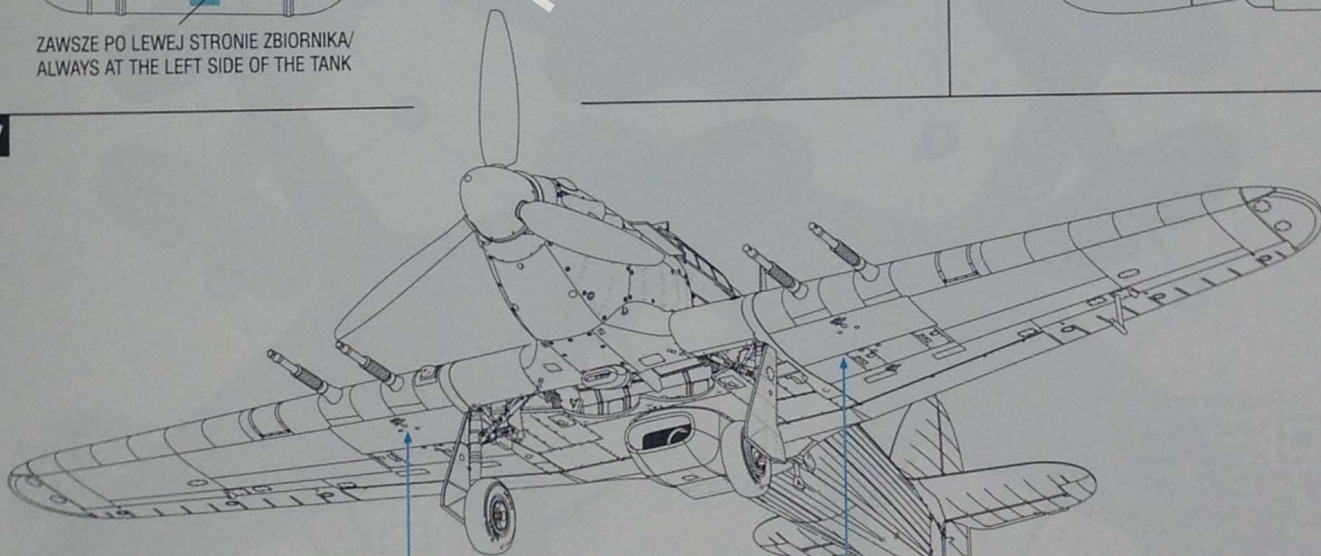

1.

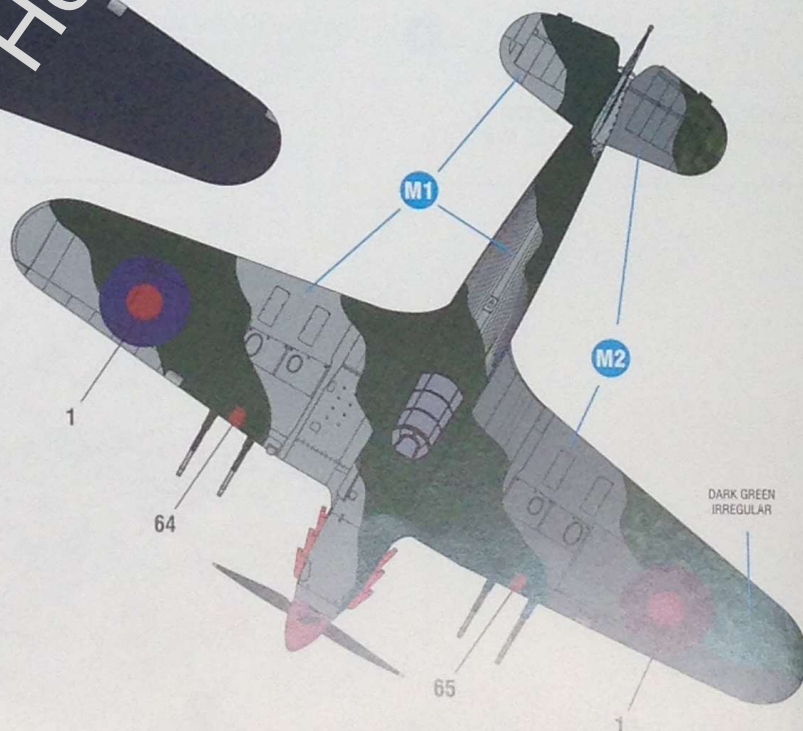
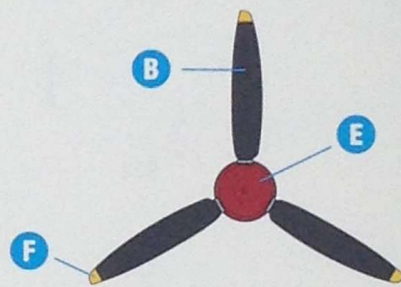
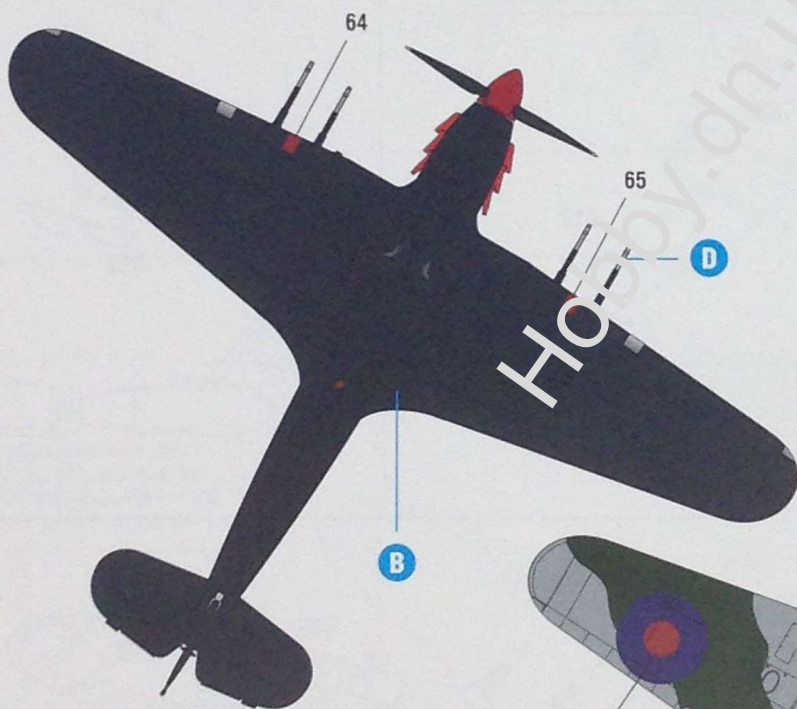
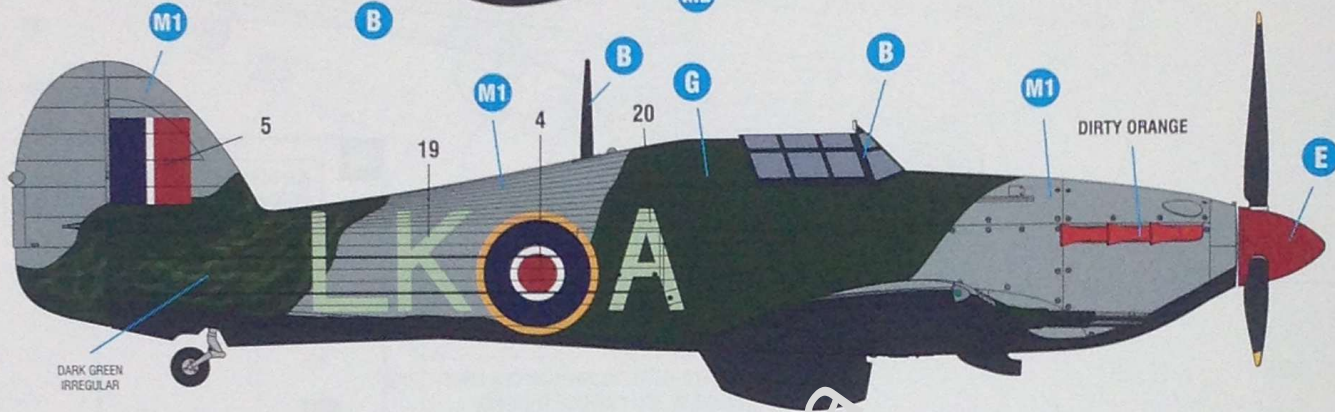
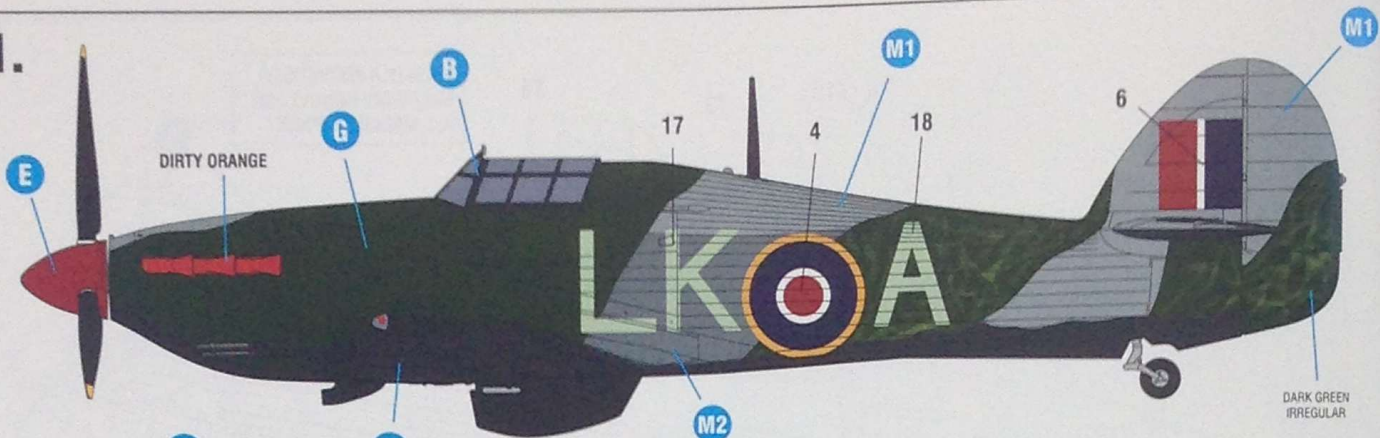

więcej/see more



<http://armahobbynews.pl/40006>

Hurricane Mk.IIc BE500/LK-A.87. Dywizjon RAF Lotnisko Tangmere. Trzy loty bojowe w operacji „Jubilee”. Piloci: S/Ldr D.G. Smallwood i F/L A.H. Thom  
 Hurricane Mk.IIc BE500/LK-A.87 Squadron RAF Tangmere airfield. Three missions in operation „Jubilee”. Pilots: S/Ldr D.G. Smallwood and F/L A.H. Thom

2.

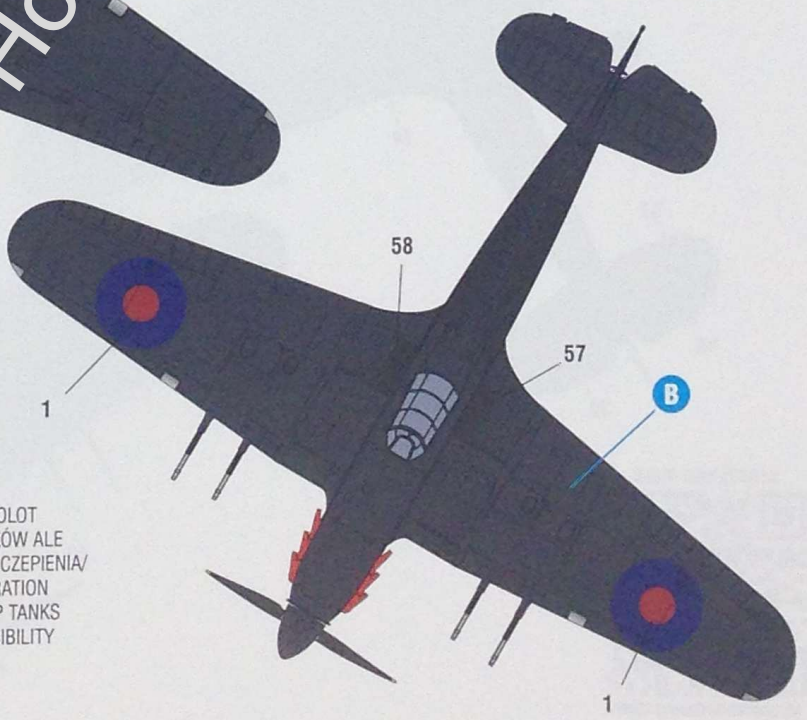
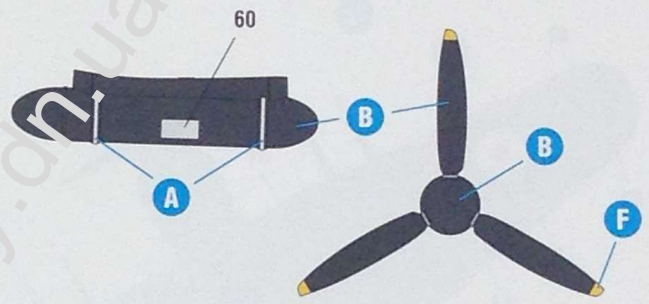
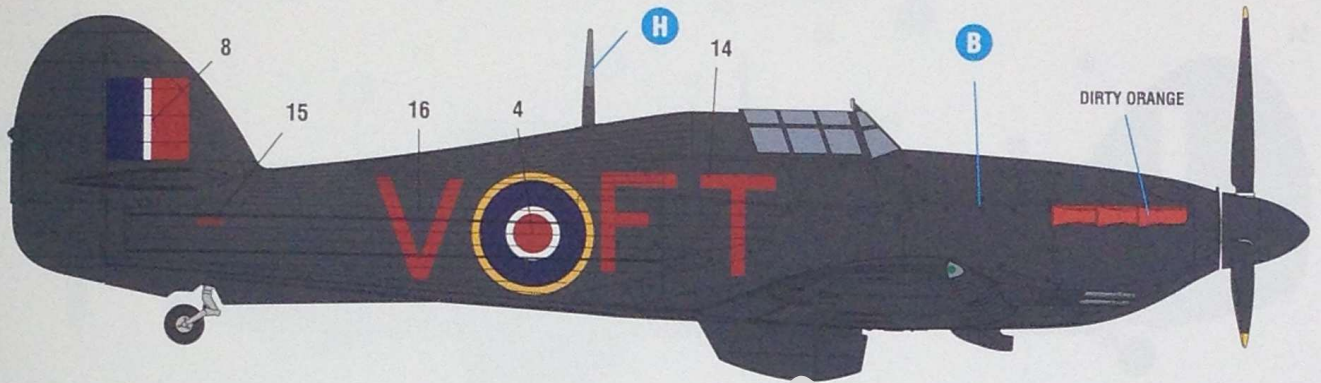

więcej/see more

<http://armahobbynews.pl/40006>

W OPERACJI JUBILEE SAMOŁOT Z3081 LATAŁ BEZ ZBIORNIKÓW ALE MIAŁ MOŻLIWOŚĆ ICH PODCZEPIENIA/  
 DURING THE JUBILEE OPERATION Z3081 DIDN'T CARRY DROP TANKS ALTHOUGH HAD THIS POSSIBILITY

Hurricane Mk.IIc Z3081/FT-V „Baron Dhanis” 43. Dywizjon RAF. Lotnisko Tangmere. Trzy loty bojowe w operacji „Jubilee”. Pilot S/Ldr D.A.R.G. Le Roy du Vivier (Belgia)  
 Hurricane Mk.IIc Z3081/FT-V „Baron Dhanis” 43 Squadron RAF. Tangmere airfield. Three missions in operation „Jubilee”. Pilot S/Ldr D. A.R.G. Le Roy du Vivier (Belgium)

3.

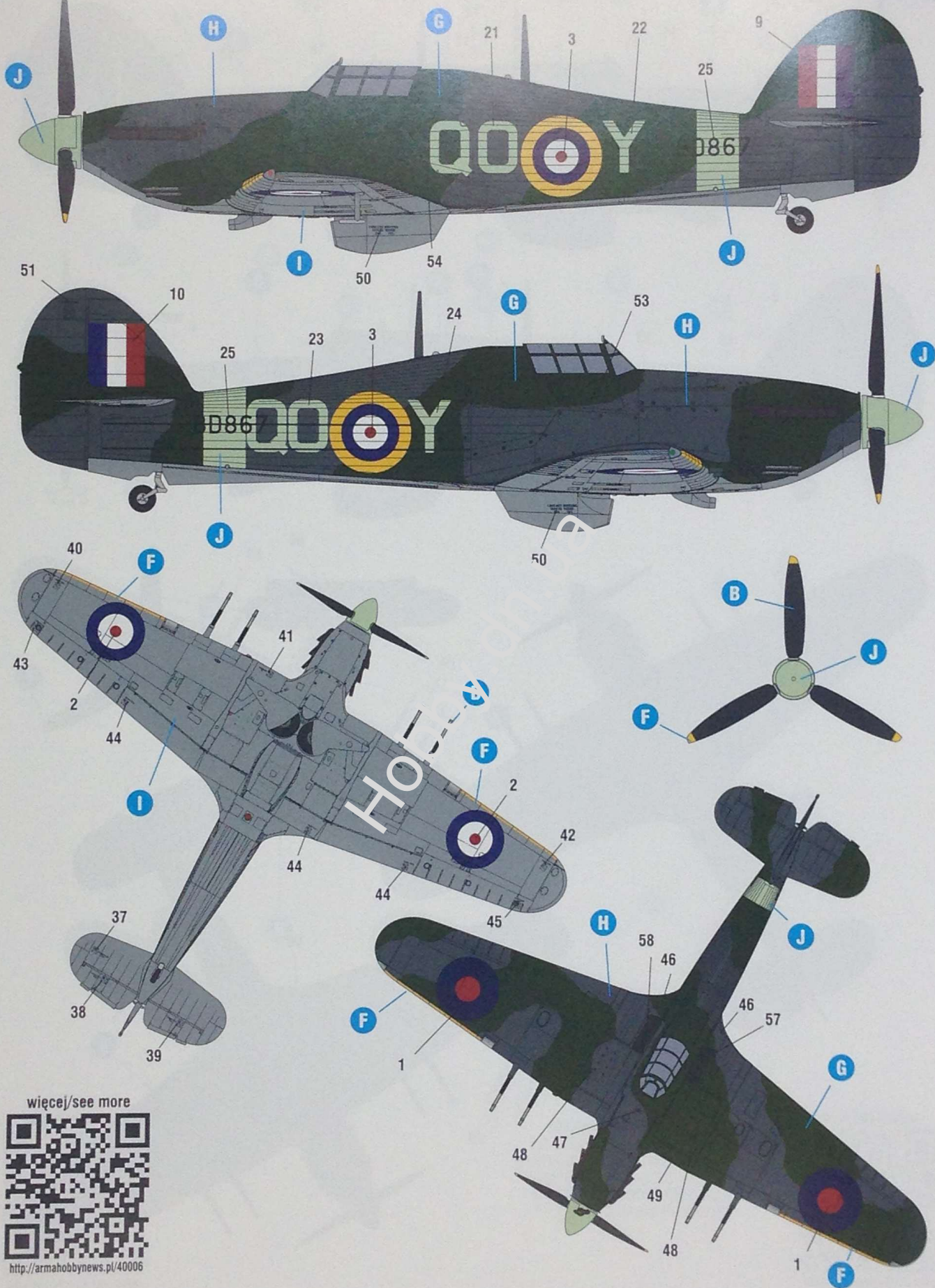

więcej/see more



<http://armahobbynews.pl/40006>

Hurricane Mk IIC BD867/QO-Y, 3. Dywizjon RAF, lotnisko Hunsdon, jesień 1941. Samolot został zestrzelony w czasie operacji „Jubilee”, pilot Sgt. Stirling David Banks (RCAF) poległ. Nie jest znany wygląd i oznakowanie samolotu z 19 sierpnia 1942 r.

Hurricane Mk IIC BD867/QO-Y, No. 3 Squadron RAF, Hunsdon airfield, Autumn 1941. This aeroplane was shot down during the “Jubilee” operation, pilot Sgt. Stirling David Banks (RCAF) died. The appearance and marking of this plane on 19th August 1942 is unknown.

Contains plastic kit,  
decals, masks

# Hurricane Mk IIb

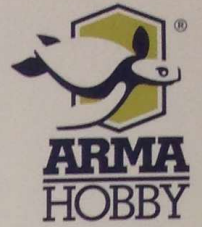

40007



Hurricane Mk.IIb "Hurribomber", BE489/AE-Q "Butch the Falcon", 402 Sqn RCAF, Warmwell, luty 1942 r.

Hurricane Mk.IIb "Hurribomber", BE489/AE-Q "Butch the Falcon", 402 Sqn RCAF, Warmwell, February 1942.



Hurricane Mk.IIb Z3171/SW-P "Hyderabad City", 253 Dywizjon RAF, Hibaldstow, pilot F/SGT. J.C. Tate, zima 1941/42 r.

Hurricane Mk.IIb Z3171/SW-P "Hyderabad City", 253 Squadron RAF, Hibaldstow, pilot F/SGT. J.C. Tate, winter 1941/42.



Hurricane Mk. IIb, Z3675/WX-B, 302 Dywizjon PSP, Church Stanton, sierpień 1941 r.

Hurricane Mk. IIb, Z3675/WX-B, 302 Squadron PAF, Church Stanton, August 1941.