

#### Uwaga!

Przed rozpoczęciem pracy dokładnie przeczytaj instrukcję. Zachowaj zasady bezpieczeństwa przy pracy z łatwopalnym klejem i farbami! Trzymaj model z dala od małych dzieci. Nie pozwalaj im brać do ust/nosa części plastikowych lub naciągając na głowę torebek plastikowych!

**Wsparcie klienta:** W przypadku jakichkolwiek problemów z modelem bez wahania wypełnij formularz zgłoszenia na stronie:

<http://www.armahobby.pl/webpage/wsparcie-faq.html>

#### Warning!

Before you start, please read the instructions carefully. Working with flammable glue and/or paint: please follow the safety recommendation of the manufacturers. Keep out of reach of small children! Do not allow them to place plastic parts in their mouths or noses or to pull plastic bags over their heads.

**Customer care:** In case of any problems with the model, please do not hesitate to contact us and fill the claim form on our website:

<http://www.armahobby.com/webpage/wsparcie-faq.html>

Samolot **TS-11 Iskra** został skonstruowany przez Tadeusza Sołtyka i produkowany w WSK „PZL Mielec” w latach 1964-87. Miał on zapewnić Lotnictwu ludowego WP tanie i bezpieczne przeszkolenie pilotów do lotów na maszynach odrzutowych. W latach 1970-tych wprowadzono do produkcji wersję szkolno-szturmową TS-11 Iskra bis D i szkolno-rozpoznawczą TS-11 Iskra bis DF.

W 1975 r. 50 samolotów TS-11 Iskra bis D sprzedano do Indii, gdzie sprawdziły się w służbie w Akademii Sił Powietrznych w Hakimpet obok Hyderabadu. Samoloty TS-11 bis D/DF służyły w Lotnictwie przez ponad pięćdziesiąt lat szkoląc pilotów samolotów bojowych. Ze służby zostały wycofane w grudniu 2020 roku.

Uzbrojeniem samolotów TS-11 Iskra bis D/DF było działko 23 mm i cztery węzły podwieszni 100kg dla bomb lub zasobników z niekierowanymi pociskami rakietowymi MARS-4.

The **TS-11 Iskra** jet plane was constructed by Tadeusz Sołtyk and produced at WSK „PZL Mielec” factory in 1964-87. It was designed to provide the Polish People’s Army Aviation with an inexpensive and safe training platform for jet pilots. In the 1970s, the TS-11 Iskra bis D training-assault version and the TS-11 Iskra bis DF training-reconnaissance version were introduced into production.

In 1975, 50 TS-11 Iskra bis D aircraft were sold to India, where they proved themselves in service at the Air Force Academy in Hakimpet, near Hyderabad. TS-11 bis D / DF planes have served in Polish Aviation for more than five decades, training pilots of combat jet aircraft. They were withdrawn from service in December 2020.

The TS-11 Iskra bis D / DF aircraft were armed with a 23 mm cannon and four underwing pylons 100 kg for bombs or pods with MARS-4 unguided missiles.

#### Kalkomanie/Decals



#### Maski/Masks

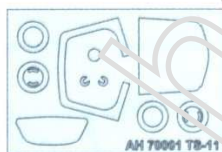

#### Części przezroczyste/Clear parts

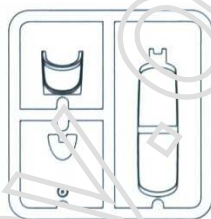

#### Elementy fototrawione/Photo etched parts

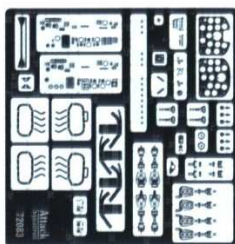

#### Części plastikowe/Plastic part

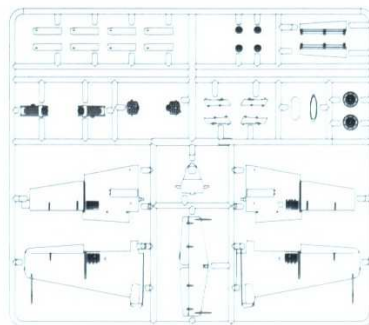
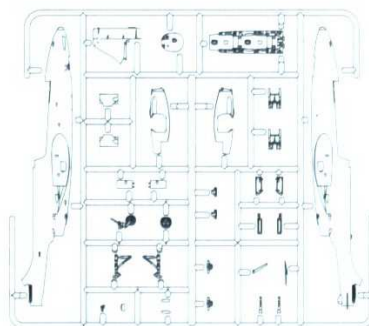

Kolory farb/ Paint colours	Hataka	Kolory farb/ Paint colours	Hataka	Kolory farb/ Paint colours	Hataka
<b>A</b> Matt Black F837038	HTK-A041/ C041*	<b>F</b> Dark Grey F838178	HTK-A158/ C158*	<b>K</b> Blue Green F835275	HTK-A129/ C129
<b>B</b> Dark Ghost Grey F838320	HTK-A035/ C035*	<b>G</b> Light Ghost Grey F838375	HTK-A037/ C037*	<b>L</b> Air Superiority Blue F835450	HTK-A155/ C155
<b>C</b> Green F834128	HTK-A221/ C221	<b>H</b> Field Green F834095	HTK-A002/ C002*	<b>t</b> Insignia Yellow F813538	HTK-A088/ C088
<b>D</b> Aluminium F817178	HTK-A078/ C078	<b>I</b> Sky Blue F825488	HTK-A005/ C005*		
<b>E</b> Insignia Red F811138	HTK-A219/ C219	<b>J</b> Desert Tan F833448	HTK-A126/ C126		



\*Kolor dostępny w zestawie Hataka AS48/CS48 / colours included in HATAKA AS48/CS48 paint set





budowa z blaszką fototrawioną 72083  
/building with photo-etched set 72083

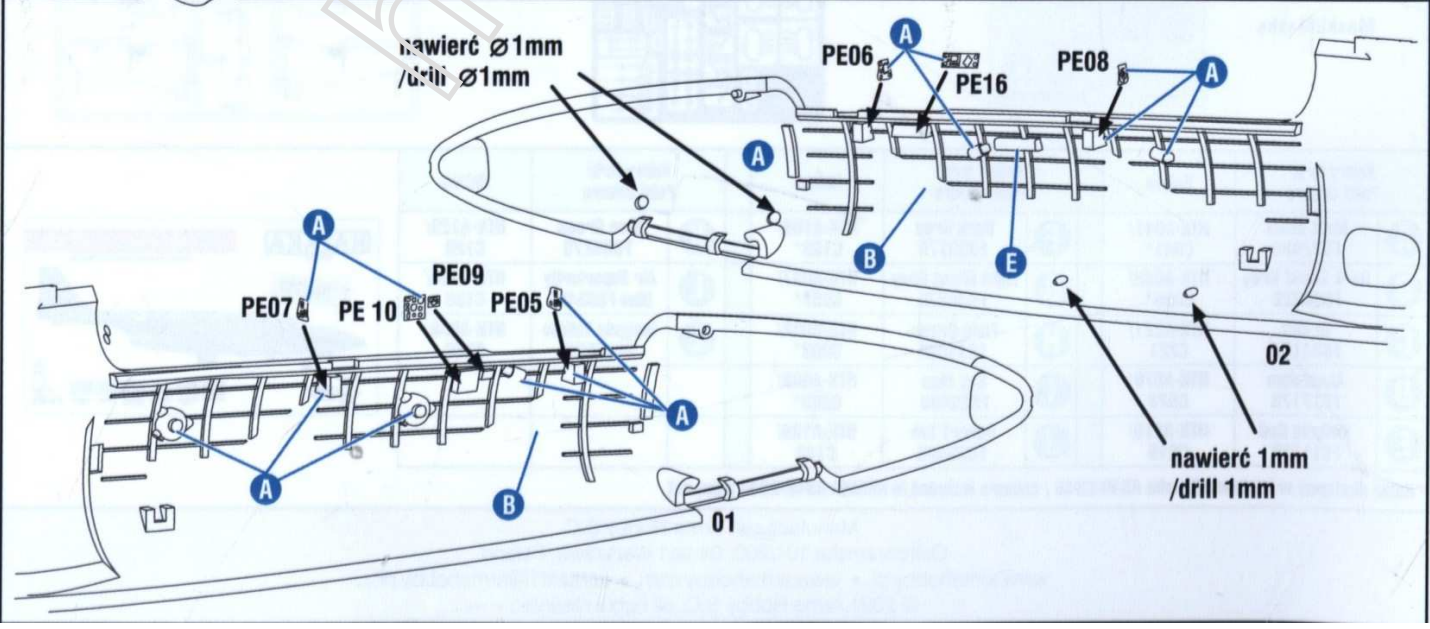
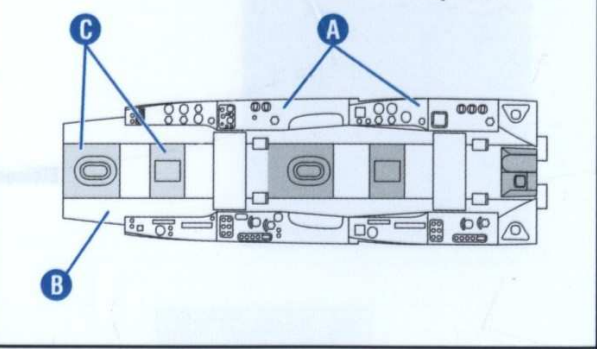
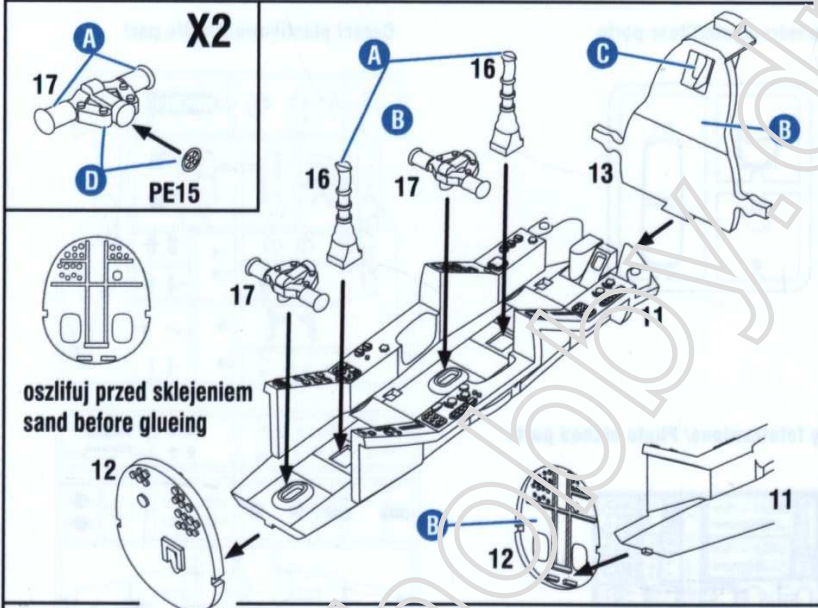
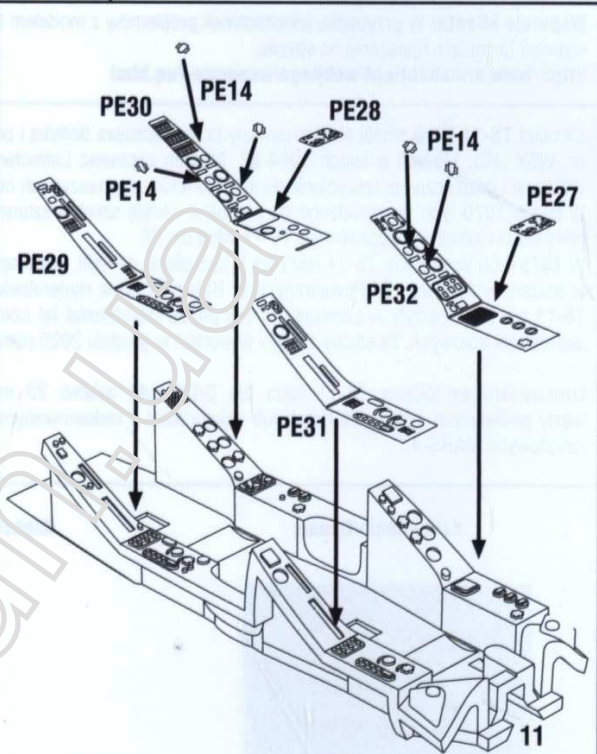
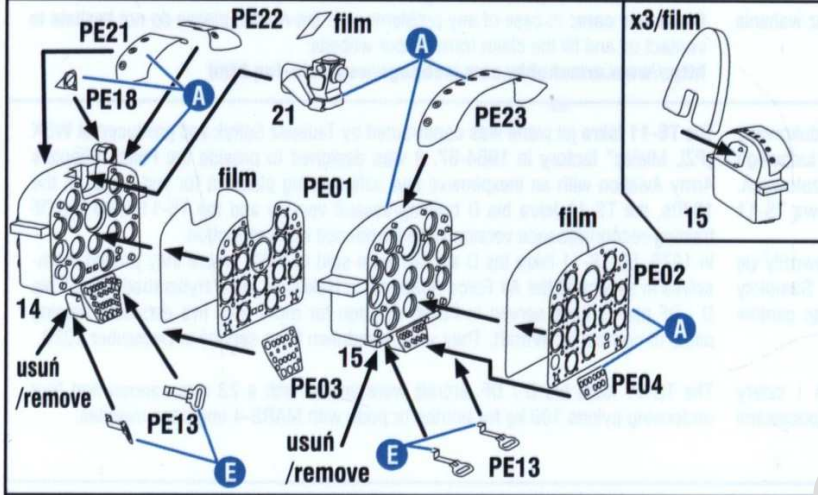
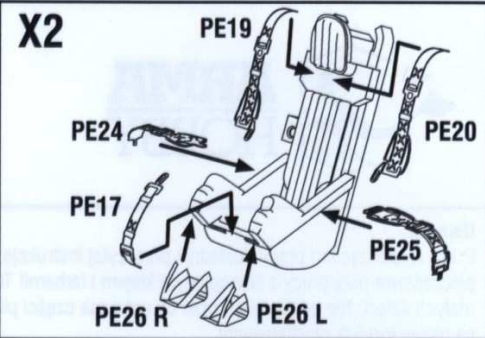
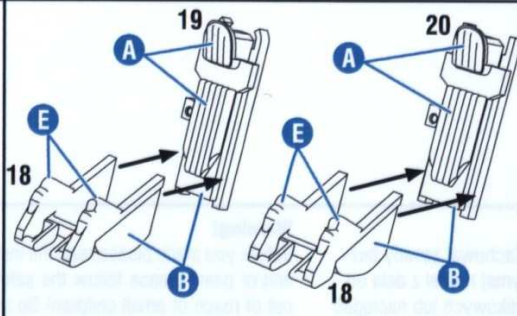



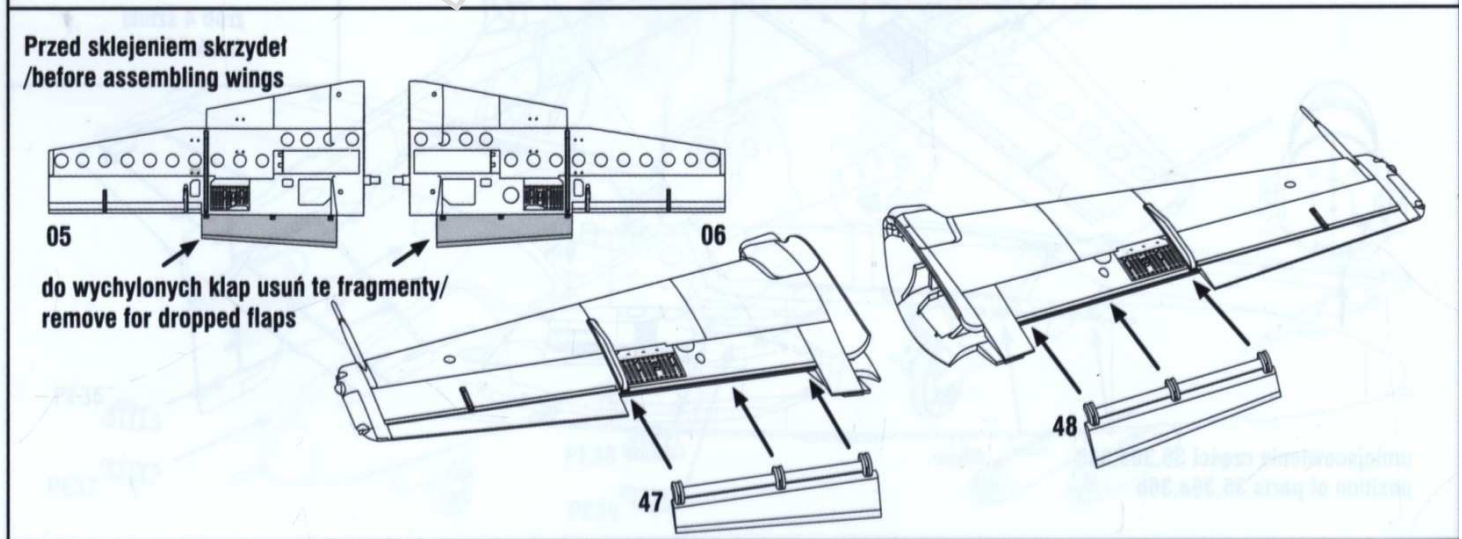
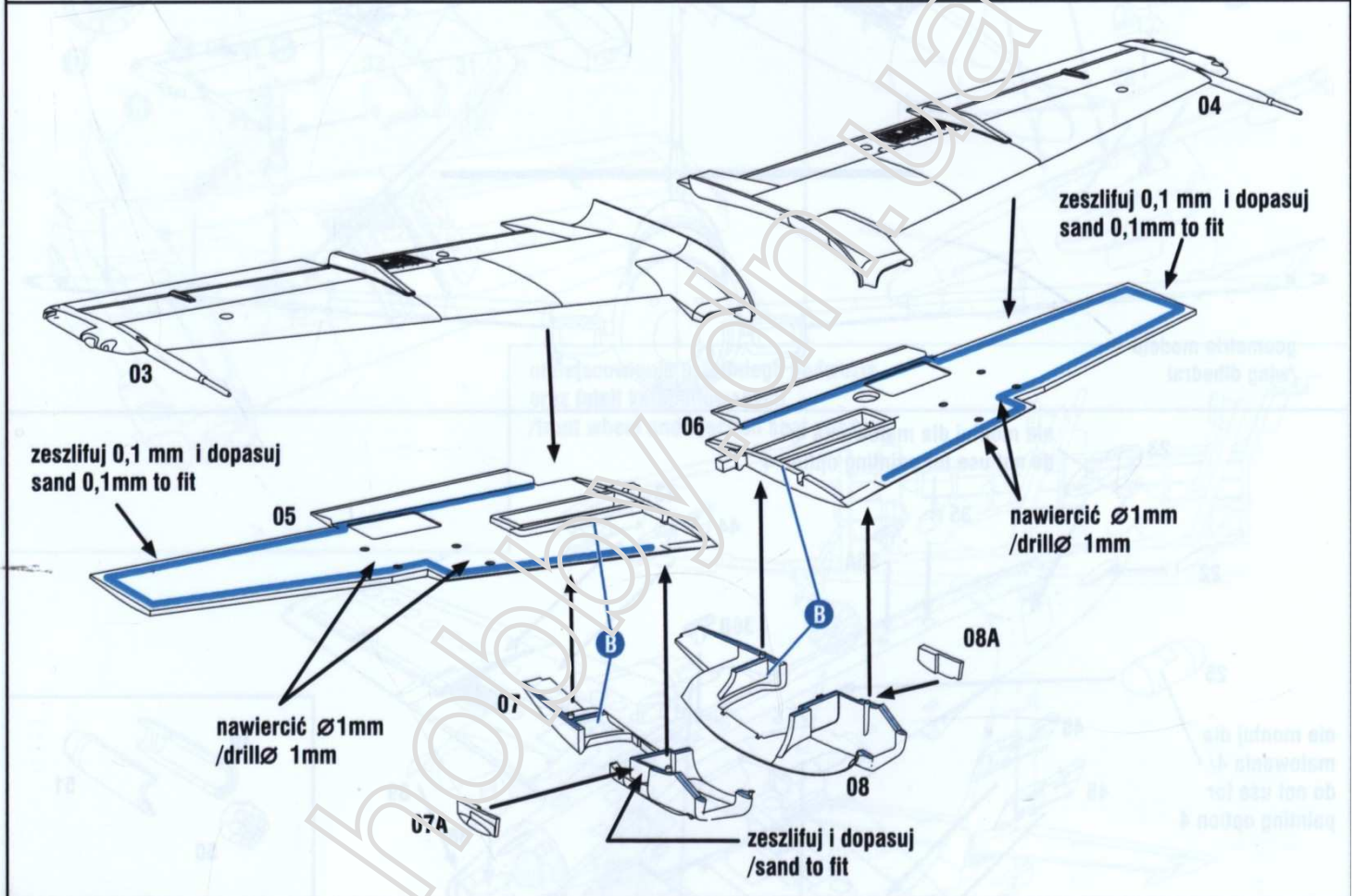
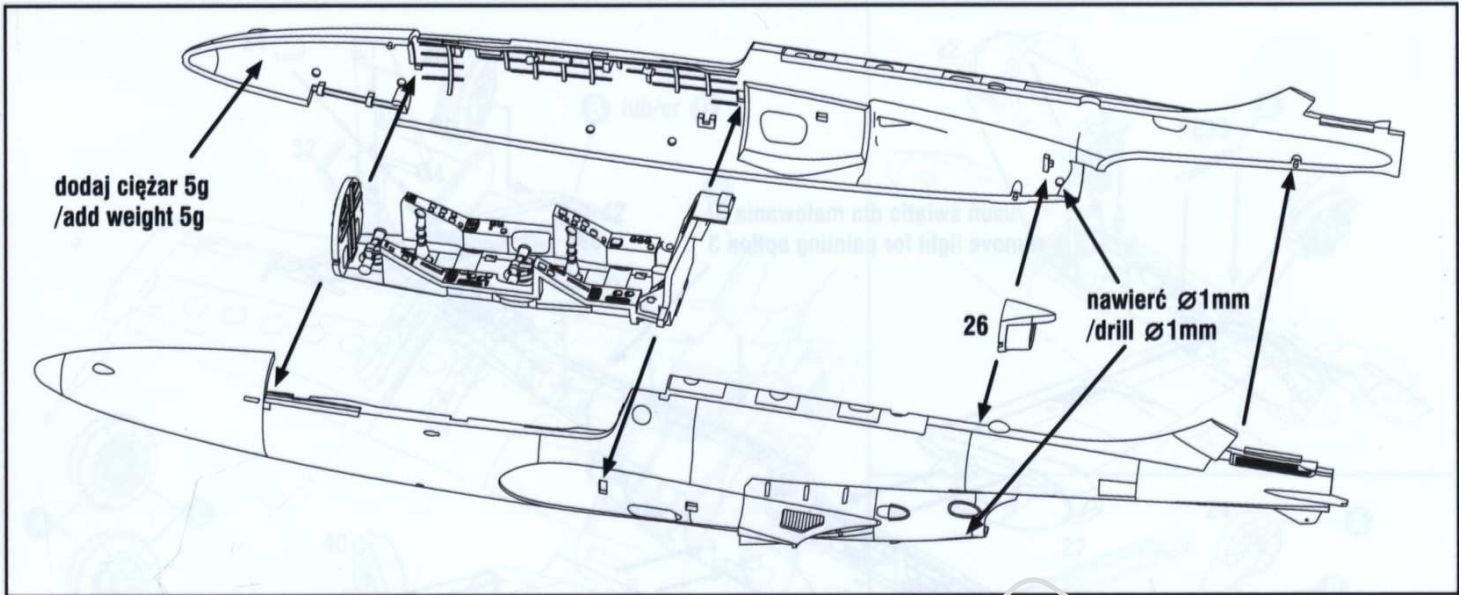



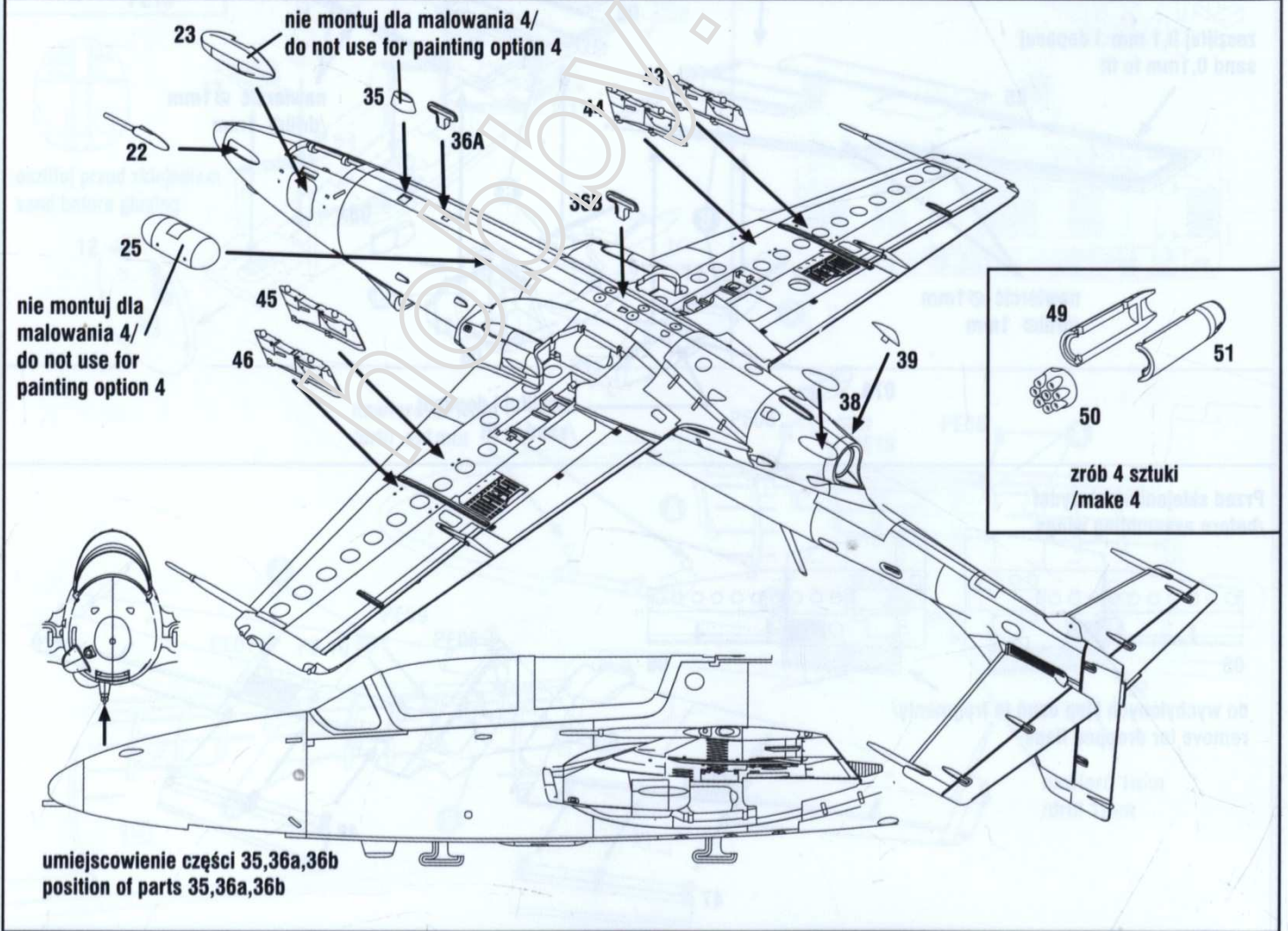
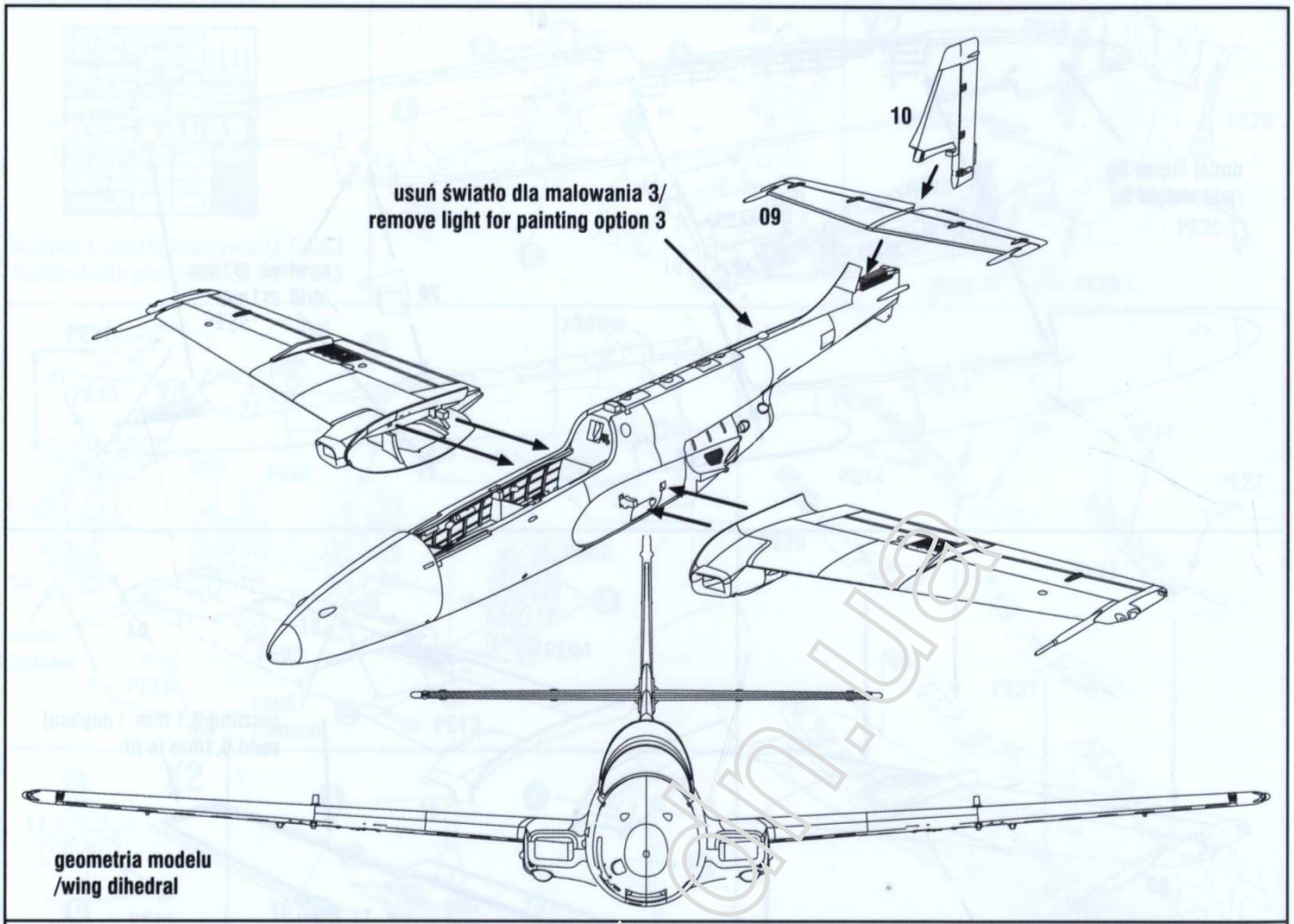



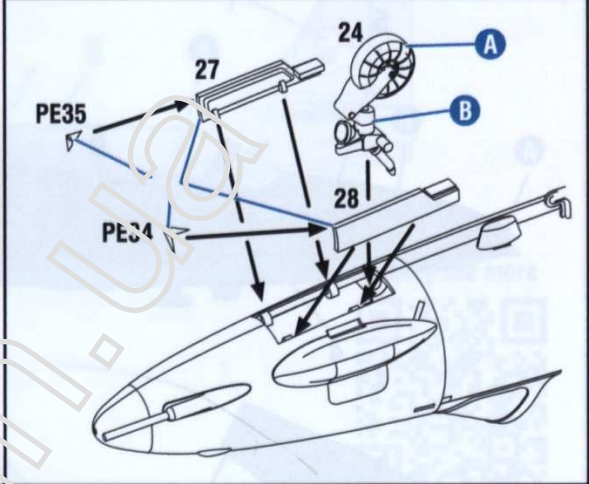
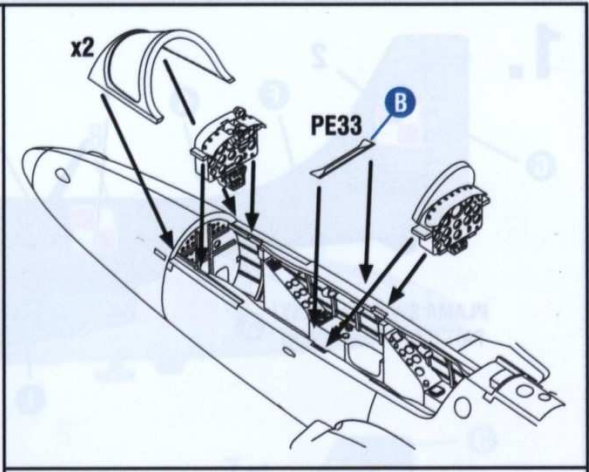
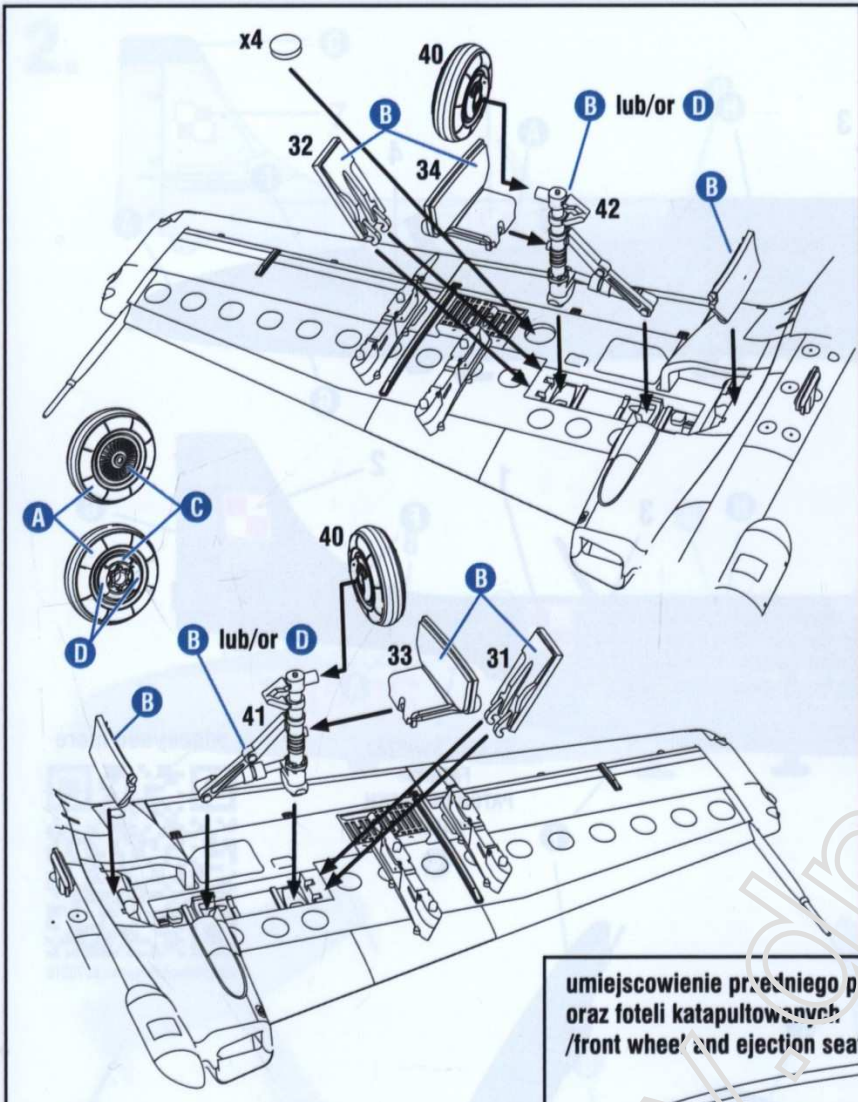

umieszczenie przedniego podwozia  
oraz foteli katapultowanych  
/front wheel and ejection seat position

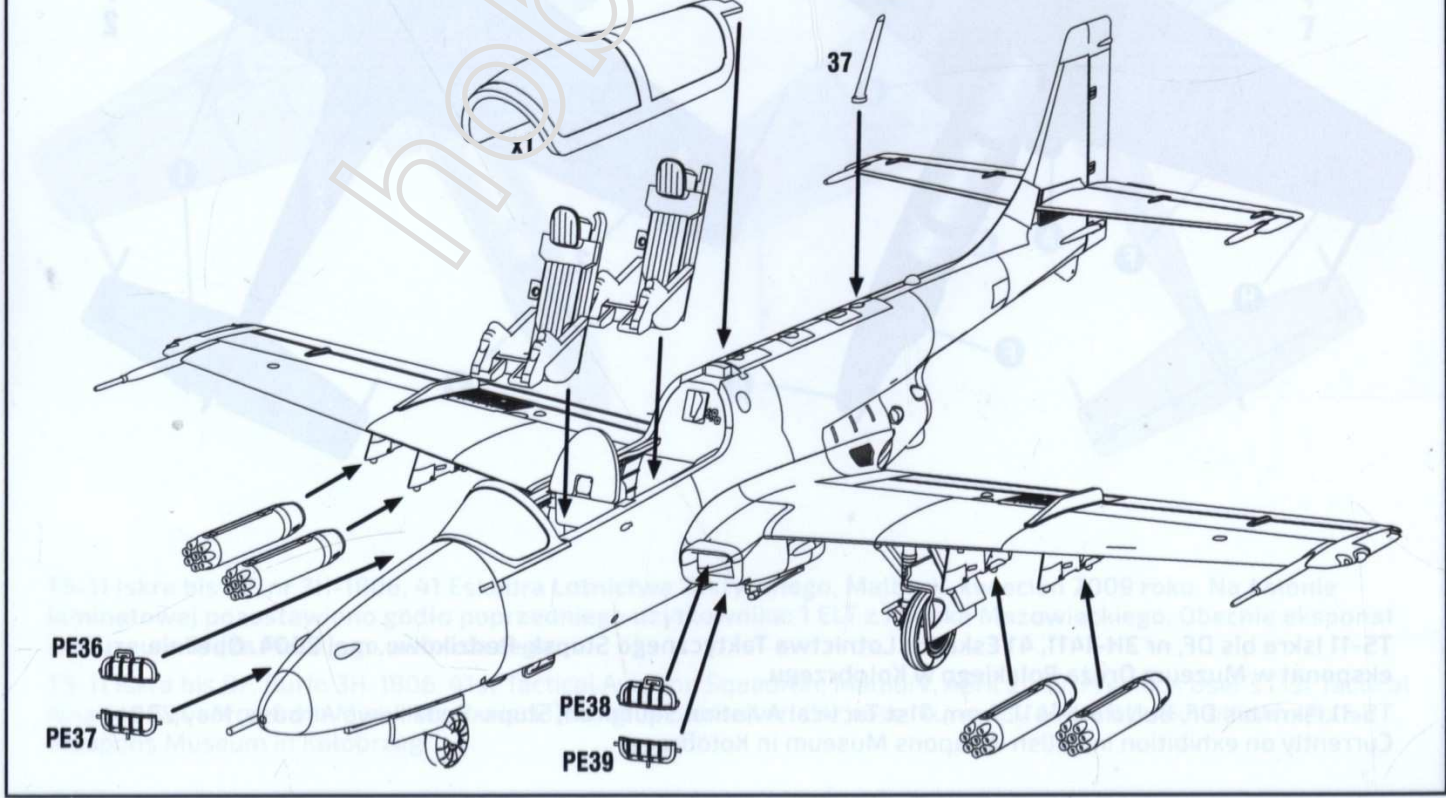
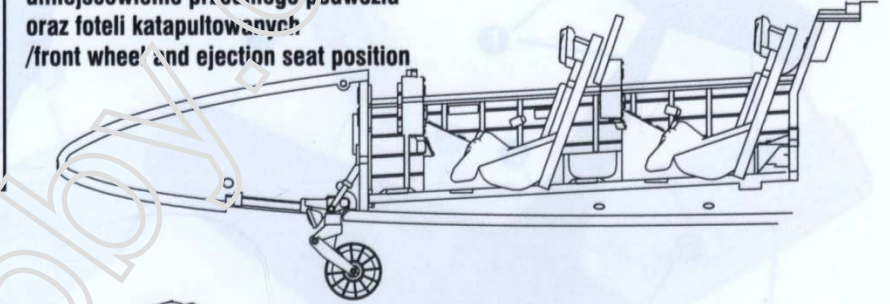



# 1.



TS-11 Iskra bis DF, nr 3H-1411, 41 Eskadra Lotnictwa Taktycznego Słupsk-Redzikowo, maj 2004. Obecnie eksponat w Muzeum Oręża Polskiego w Kołobrzegu.

TS-11 Iskra bis DF, BuNo 3H-1411, from 41st Tactical Aviation Squadron, Słupsk-Redzikowo Airbase, May 2004. Currently on exhibition in Polish Weapons Museum in Kołobrzeg.



# 2.

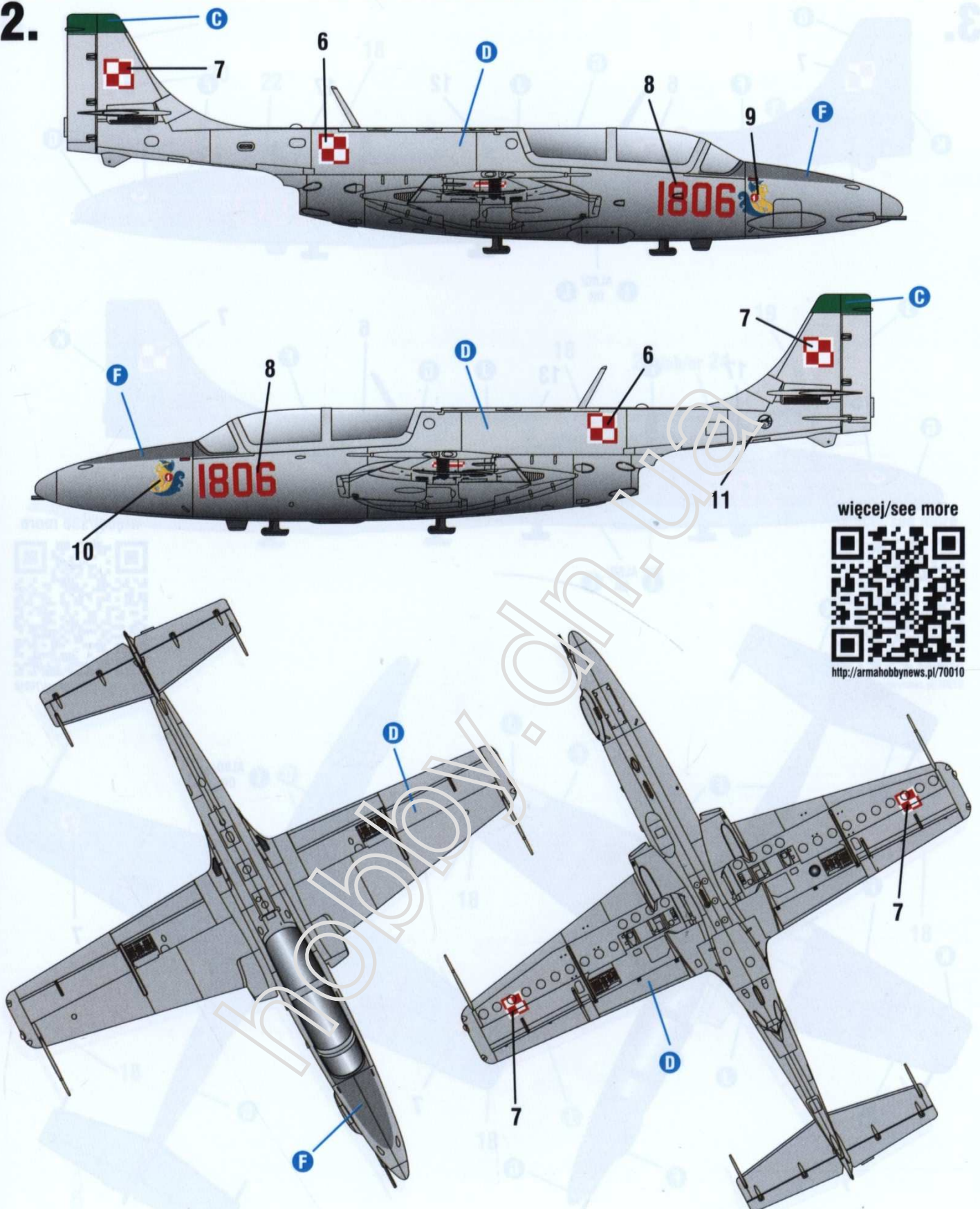

więcej/see more



<http://armahobbynews.pl/70010>

TS-11 Iskra bis DF, nr 3H-1806, 41 Eskadra Lotnictwa Taktycznego, Malbork, kwiecień 2009 roku. Na osłonie laminatowej pozostawiono godło poprzedniego użytkownika: 1 ELT z Mińska Mazowieckiego. Obecnie eksponat w Muzeum Oręża Polskiego w Kołobrzegu.

TS-11 Iskra bis DF, BuNo 3H-1806, 41st Tactical Aviation Squadron, Malbork, April 2009. Previous user's (1st Tactical Aviation Squadron from Minsk Mazowiecki) insignia painted on the nose. Currently aircraft is exhibited in Polish Weapons Museum in Kołobrzeg.



3.



więcej/see more



<http://armahobbynews.pl/70010>

TS-11 Iskra bis DF, nr 3H-2013, 7 Pułk Lotnictwa Specjalnego Marynarki Wojennej, 2 Klucz 1 Eskadra Lotnicza, Siemirowice, sierpień 1993 r.

TS-11 Iskra bis DF, BuNo 3H-2013, of the 7th Special Aviation Regiment Polish Navy, 2nd Section 1st Aviation Squadron, Siemirowice AB, August 1993.

Specjalne podziękowania dla Mitosza Rusieckiego za pomoc w odtworzeniu kamuflażu./Special Thanks to Mr Mitosz Rusiecki for help in camouflage research.



4.

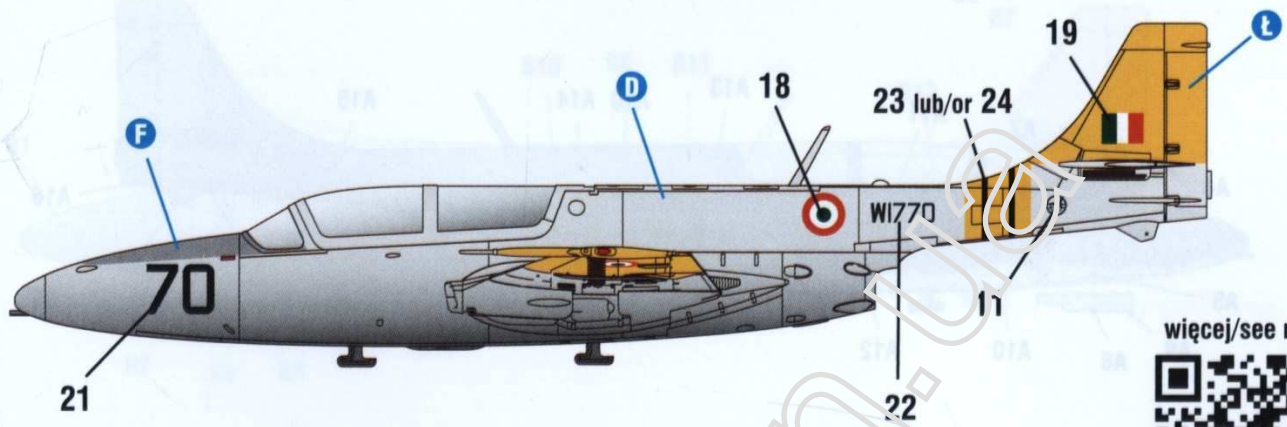
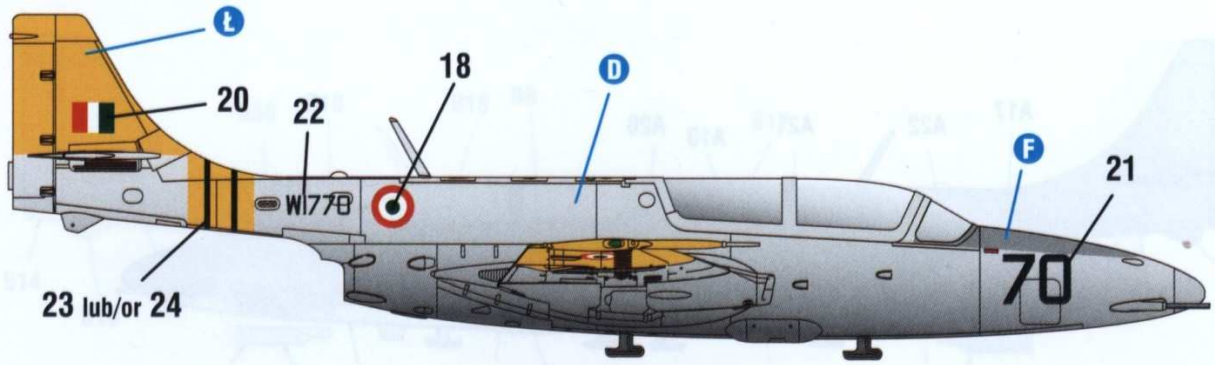

więcej/see more



<http://armahobbynews.pl/70010>

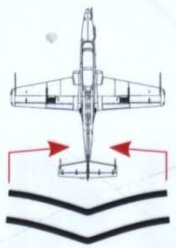
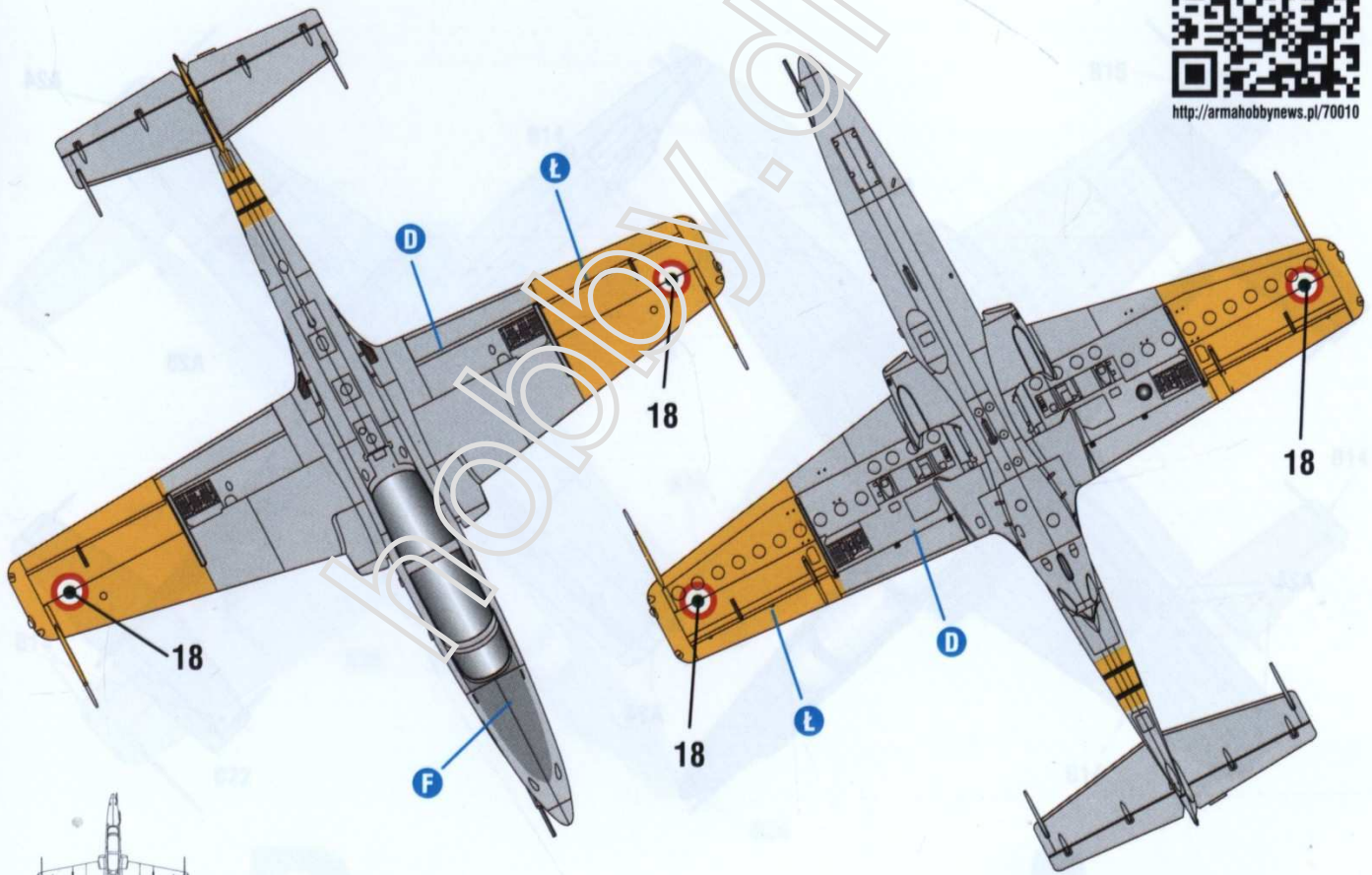

kalkomania 23, kładziona od góry  
belki ogonowej/decal 23, put it from  
the top of the tail boom

lub/or

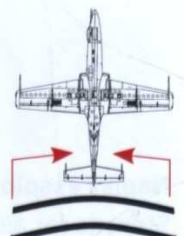

kalkomania 24, kładziona od dołu  
belki ogonowej/decal 24, put it from  
the underside of the tail boom

TS-11 Iskra D, lotnisko Hakimpet, Hyderabad w Indiach. Około 1976 r.

TS-11 Iskra D, Hakimpet airfield, Hyderabad, India 1976.



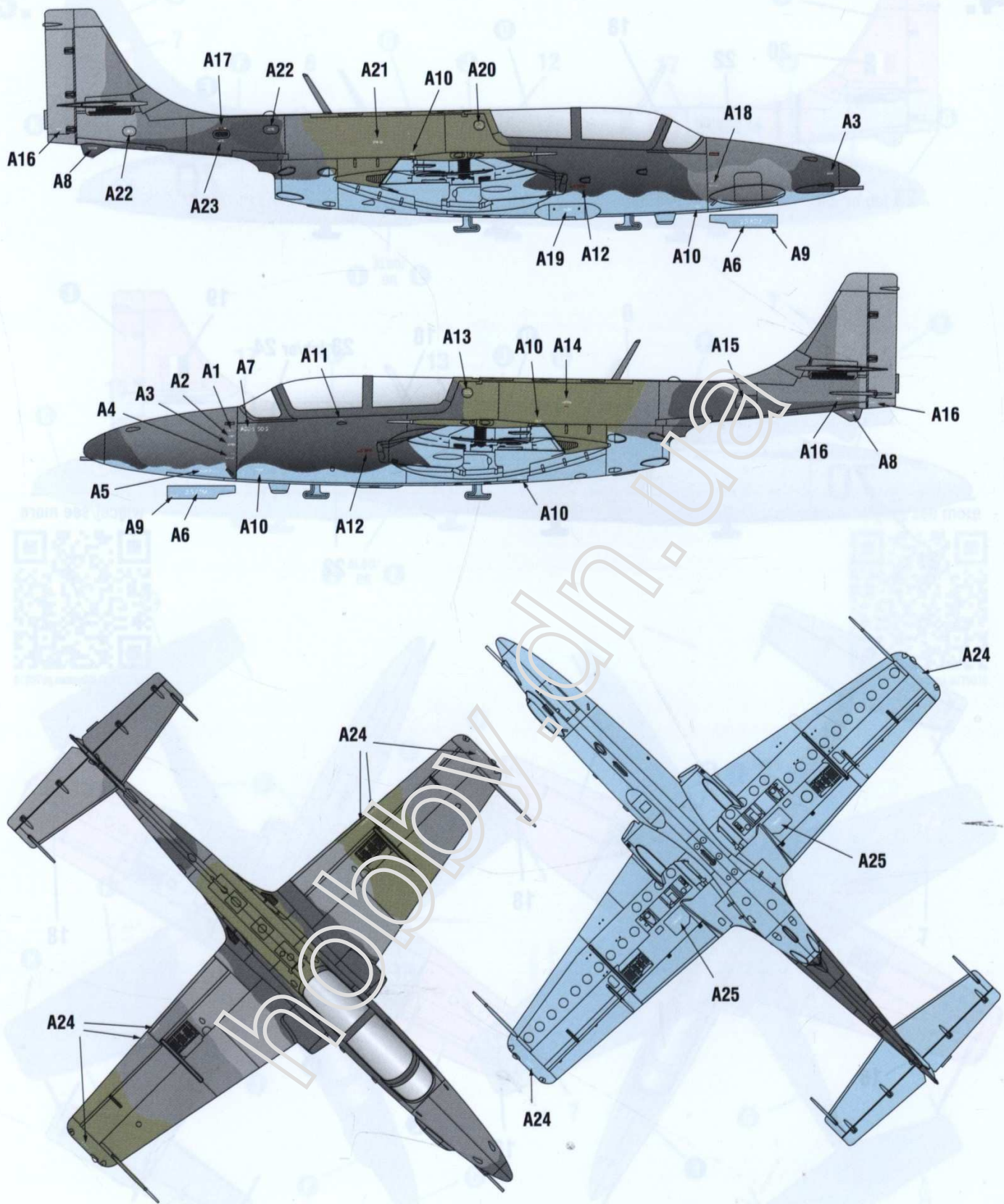

A

1411

Napisy eksploatacyjne dla samolotu o numerze 1411.  
 Stencils for airplane No 1411 painted with camouflage colors.



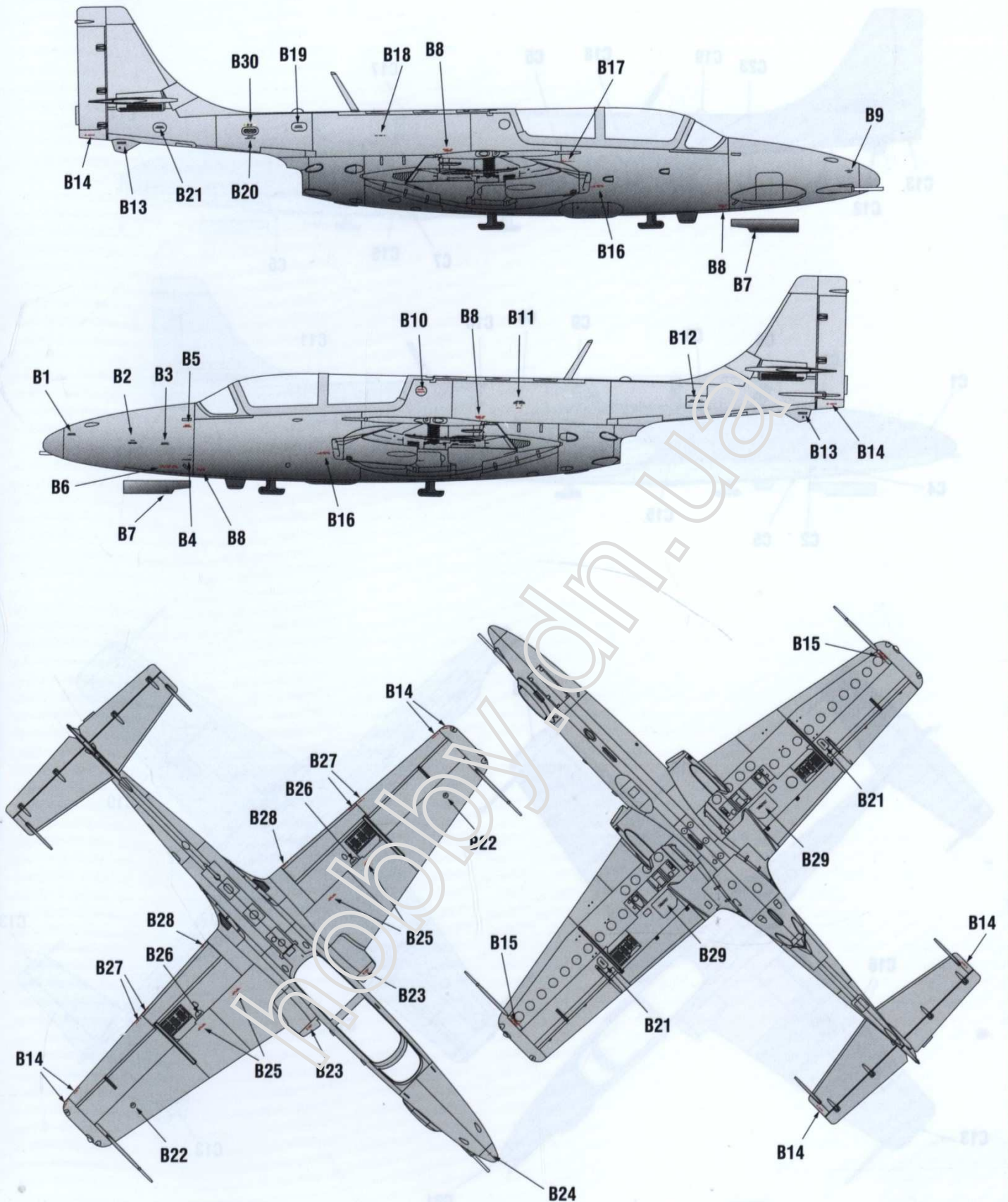

**B**

**1806**

Napisy eksploatacyjne dla samolotu 1806.  
 Stencils for airplane 1806 without camouflage colors.



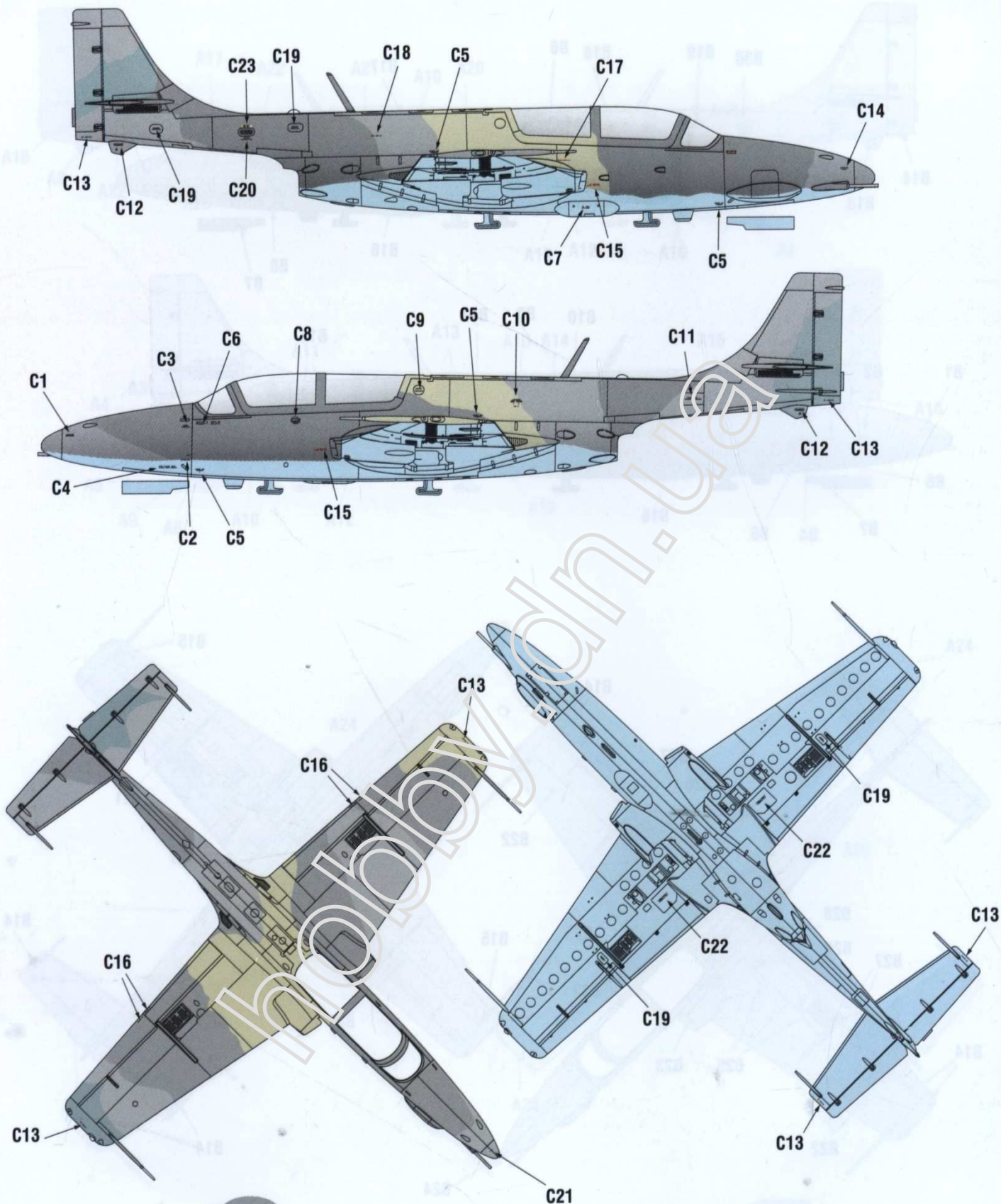

C

2013

Napisy eksploatacyjne dla samolotu o numerze 2013.  
 Stencils for airplane No 2013 painted with camouflage colors.