

Uwaga!

Przed rozpoczęciem pracy dokładnie przeczytaj instrukcję. Zachowaj zasady bezpieczeństwa przy pracy z łatwopalnym klejem i farbami! Trzymaj model z dala od małych dzieci. Nie pozwalaj im brać do ust/nosa części plastikowych lub naciągać na głowę torebek plastikowych!

Wsparcie klienta: W przypadku jakichkolwiek problemów z modelem bez wahania wypełnij formularz zgłoszenia na stronie:

<http://www.armahobby.pl/webpage/wsparcie-faq.html>

Warning!

Before you start, please read the instructions carefully. Working with flammable glue and/or paint: please follow the safety recommendation of the manufacturers. Keep out of reach of small children! Do not allow them to place plastic parts in their mouths or noses or to pull plastic bags over their heads.

Customer care: In case of any problems with the model, please do not hesitate to contact us and fill the claim form on our website:

<http://www.armahobby.com/webpage/wsparcie-faq.html>

P-39 Airacobra to jeden z najciekawszych i najbardziej innowacyjnych myśliwców II wojny światowej – konstruktorzy z firmy Bell wyposażyli go w przednie kołko, silnik w środku ciężkości płatowca i solidne działo 37 mm. Silnik w pierwotnym założeniu był wyposażony w turbosprężarkę, zapewniającą oblatanemu wiosną 1939 roku prototypowi znakomite osiągi na dużych wysokościach. Jednak urzędnicy amerykańskiego lotnictwa woleli napęd prostszy, dostosowany do operowania na mniejszym pułapie. Wdrażanie Airacobry do produkcji seryjnej i jednostek bojowych przypadło na szybko zmieniające się okoliczności związane z wybuchem wojny w Europie, a potem na froncie wschodnim i Pacyfiku. Pierwsze zamówienia dla Francji i Wielkiej Brytanii nie zostały w pełni zrealizowane, część z nich przekierowano bezpośrednio do sił USA walczących na Pacyfiku i w Afryce. Po pojawieniu się doskonalszych typów samolotów, ponad połowę z 9558 wyprodukowanych Cobr wysłano w ramach Lend-Lease do Związku Radzieckiego, gdzie samolot sprawdzał się doskonale: walki toczono tam na niewielkim pułapie, do jakiego Airacobra była najlepiej dostosowana. Spośród 10 czołowych sowieckich asów, połowa latała na Airacobrach. W związku z ciągłymi modyfikacjami, wynikającymi zarówno z potrzeb operacyjnych, jak i czysto technologicznych, pierwszą naprawdę masowo produkowaną wersją samolotu była dopiero P-39N. Airacobr N powstało ponad 2 tysiące, używały ich siły powietrzne USA na Pacyfiku, w Afryce i w Europie, Francuzi, Włosi, ale ponad połowa trafiła do ZSRR, gdzie latały na nich i zwyciężyli najwybitniejsi piloci elitarnych pułków gwardyjskich. Lotnictwo USA zastępowało myśliwce P-39N Airacobra nowszymi typami na przełomie lat 1943 i 1944, ale w innych krajach pozostały w aktywnej służbie frontowej aż do końca wojny.

The P-39 Airacobra is one of the most interesting and innovative fighters of World War II - Bell designers equipped it with a front wheel, an engine in the centre of gravity of the airframe and a solid 37 mm cannon. The engine was originally equipped with a turbo-supercharger, which provided the prototype flown in the spring of 1939 with excellent performance at high altitudes. However, US aviation officials preferred less-complex propulsion, fit to operate at a lower altitude. The implementation of Airacobra into mass production and combat units coincided with the rapidly changing circumstances related to the outbreak of war in Europe, and then on the Eastern and Pacific fronts. The first orders for France and Great Britain were not fully delivered, some of them were transferred directly to the US forces fighting in the Pacific and North Africa. With the advent of more effective aircraft types, more than half of the 9,558 produced Cobras were sent under Lend-Lease to the Soviet Union, where the aircraft performed excellently: battles were fought at the low altitude for which the Airacobra was best suited. Of the top 10 Soviet aces, half flew Airacobras. Due to constant modifications resulting from both operational and purely technological needs, the first truly mass-produced version of the aircraft was only the P-39N. Over 2,000 Airacobras N were built, and used by the US Air Force in the Pacific, Africa and Europe, the French and Italians, but more than half went to the USSR, where the most outstanding aces of the elite Guards regiments flew them and achieved victories. The US Air Force replaced operational P-39N Airacobra fighters with newer types in late 1943 and early 1944, but in other countries they remained in active frontline service until the end of the war.

Kalkomanie/Decals



Części przezroczyste/ Transparent parts

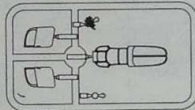

Ramka /Frame



obciążenie/weight

Maski/Masks

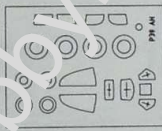

Druk 3D/3D Parts



Części plastikowe/Plastic parts

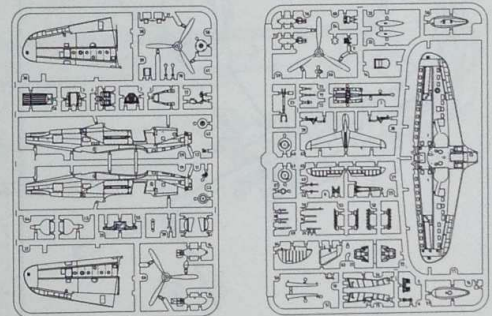







Więcej informacji na temat budowy tego modelu: <http://armahobbynews.pl/blog/tag/nr70057/>

More advice on building this kit: <http://armahobbynews.pl/en/blog/tag/nr70057-en/>

Kolory farb/ Paint colours	Hataka	AK RC	HUMBROL	AMMO	MISSION MODELS	Vallejo	Tamiya	Kolory farb/ Paint colours	Hataka	AK RC	HUMBROL	AMMO	MISSION MODELS	Vallejo	Tamiya
A Matt Black	HTK-A041/ C041	RC001	33	046	MMP- 047	71.057	XF-1	G Zinc Chromate Yellow	HTK-A330/ C330*	RC263	81*	221	MMP-67	71.107	XF-4
B Aluminium	HTK-A078/ C078	RC020	11	194	MMM- 003	71.062	XF-16	H Olive Drab	HTK-A018/ C018	RC259	155	240	MMP- 091	71.016	XF-62
C Bell Green	HTK-A056/ C056	RC260	149	238	MMP-66	71.124	XF-26	I Dark Green DuPont 71-013	HTK-A016/ C016	RC286	116	915	MMP- 058	71.324	XF-81
D Insignia White	HTK-A049/ C049	RC013	34	047	MMP- 104	71.001	XF-2	J Dark Earth DuPont 71-009	HTK-A009/ C009	RC287	118	070	MMP- 078	71.323	XF-52
E Insignia Yellow	HTK-A066/ C066	RC008	154	048	MMP- 007	71.002	XF-3	K Sky Type-S Grey DuPont 71-021	HTK-A039/ C039	RC285	28	226	MMP- 080	70.989	XF-19
F Gunmetal	HTK-A106	RC015	53	045	MMM- 010	71.073	X-10	L Neutral Grey	HTK-A033/ C033	RC261	176	239	MMP- 089*	71.051	XF-53

*Kolor zbliżony/similar colour

 symetrycznie/ symmetrically	 kalkomania/ decals	 zegnij/ bend	 usuń/ remove	 nawierć/ drill	 zwini/ roll
--	---	---	---	---	--

Manufacturer:

Arma Hobby S.C. Ostrobramska 101/200, 04-041 Warszawa, Poland
www.armahobby.pl; www.armahobby.com; kontakt1@armahobby.pl

© 2023 Arma Hobby S.C. all rights reserved

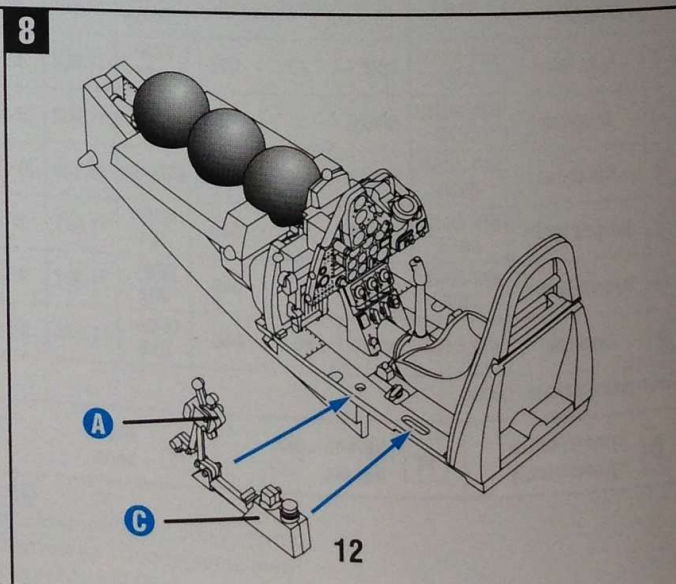
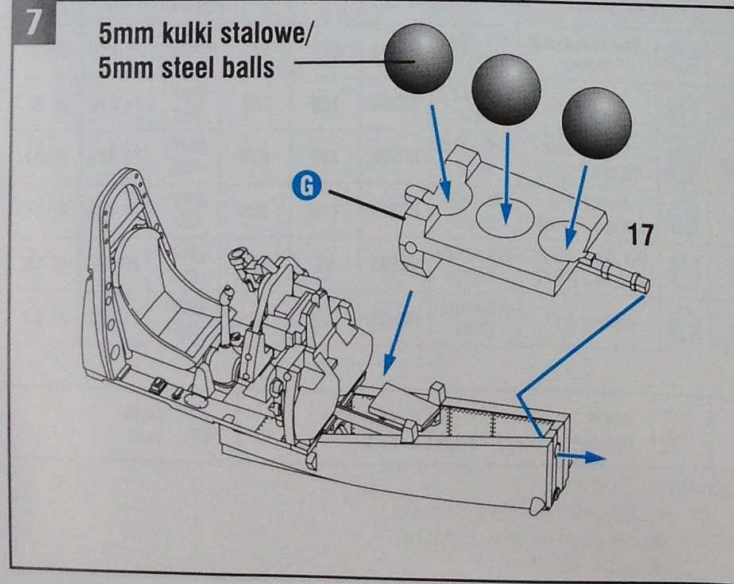
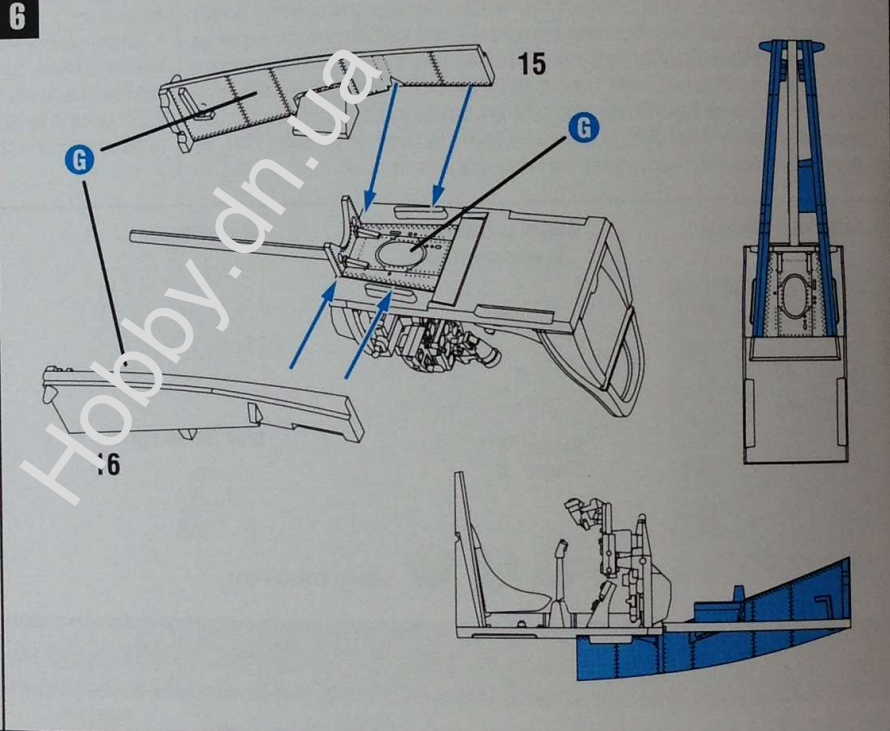
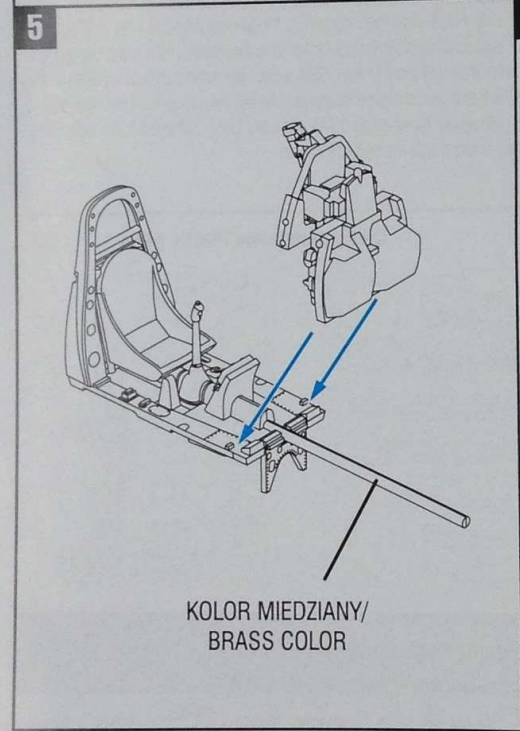
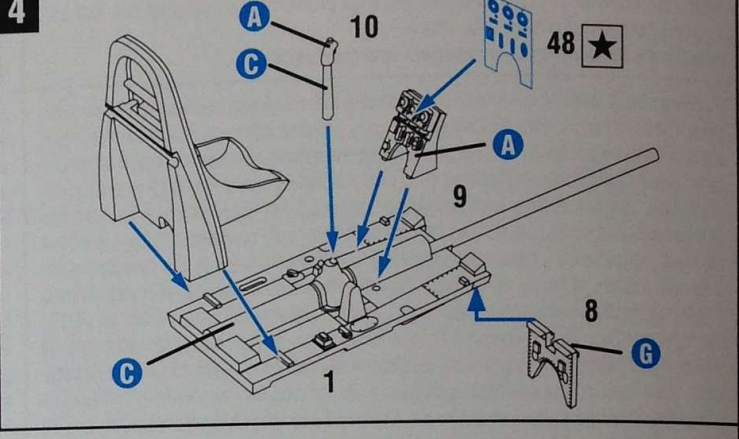
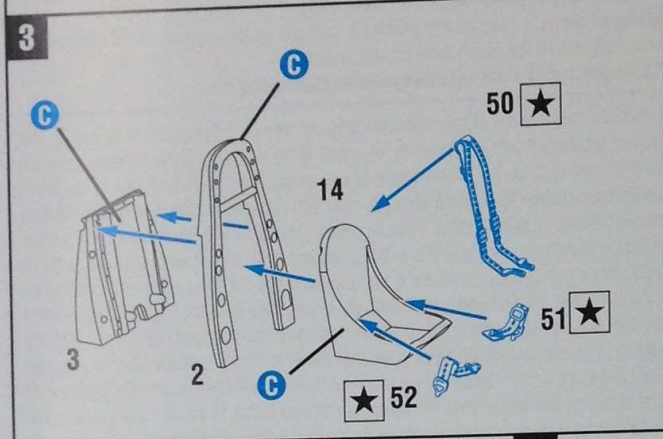
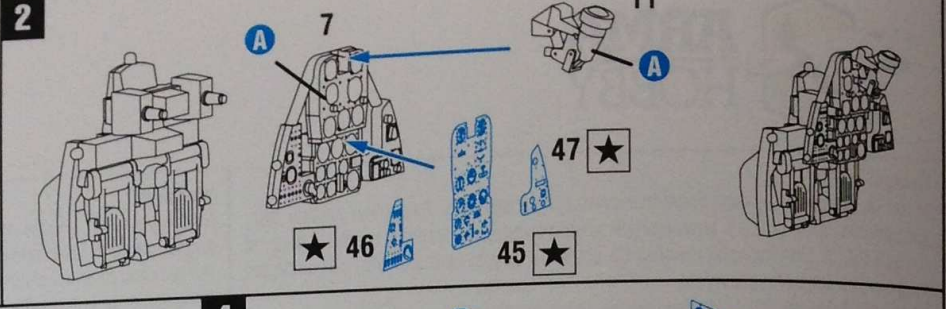
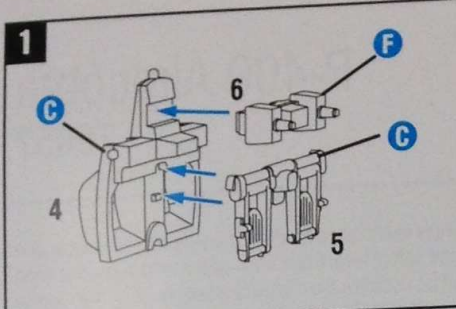

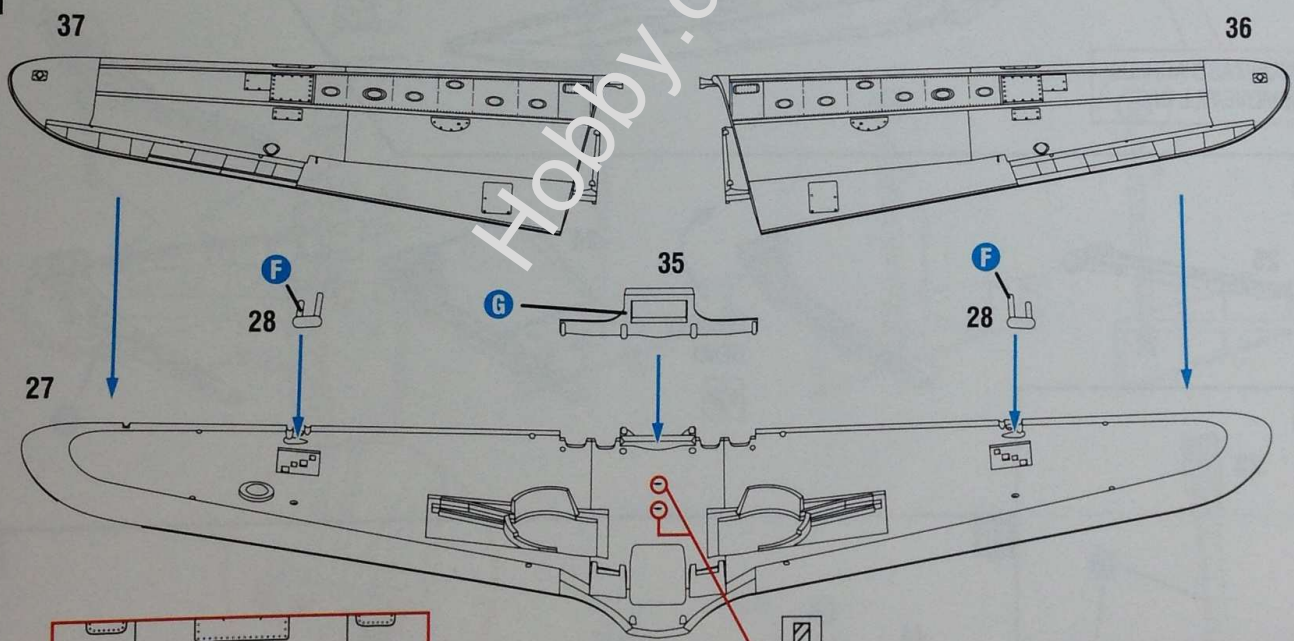
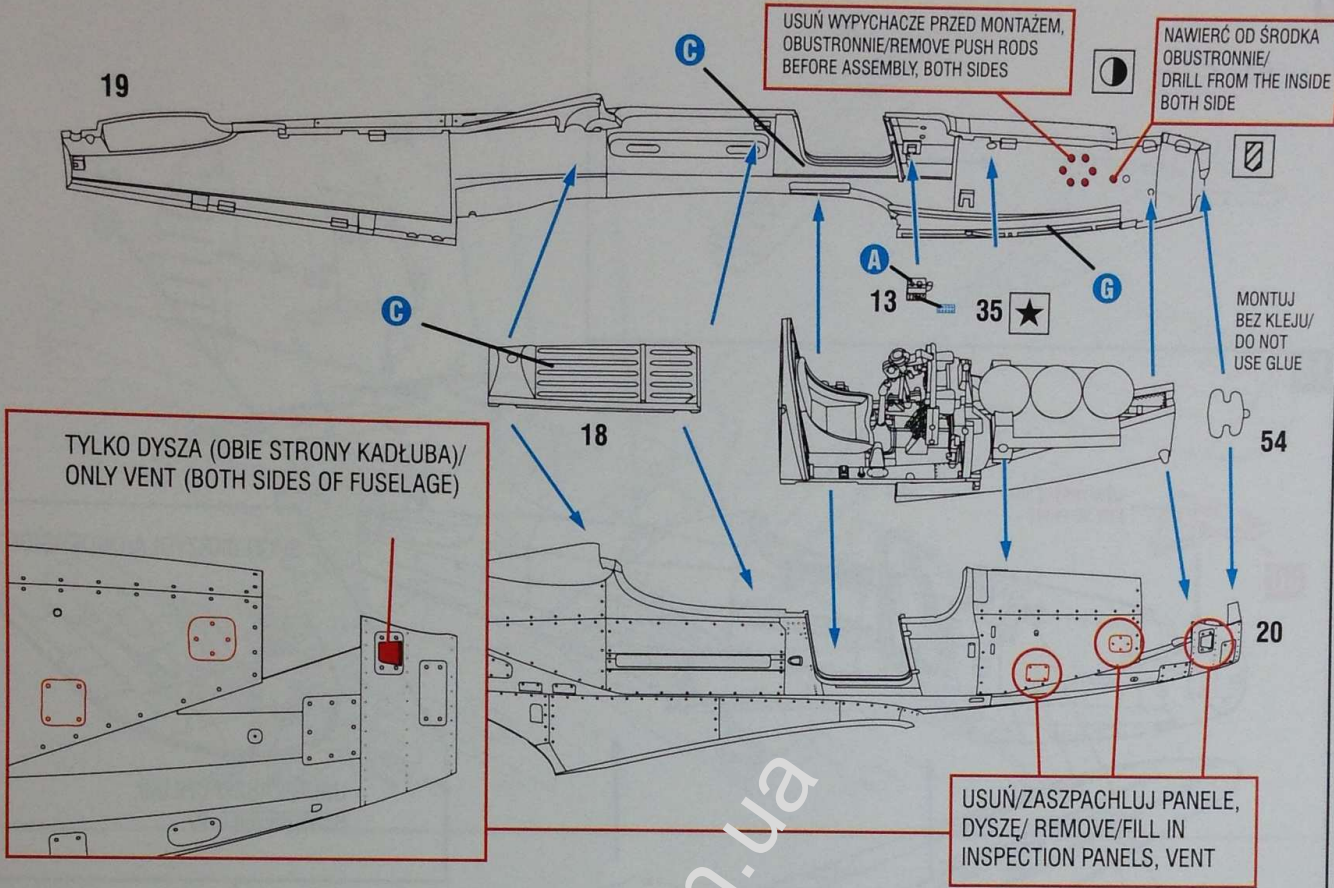

12

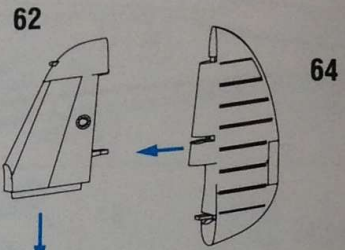
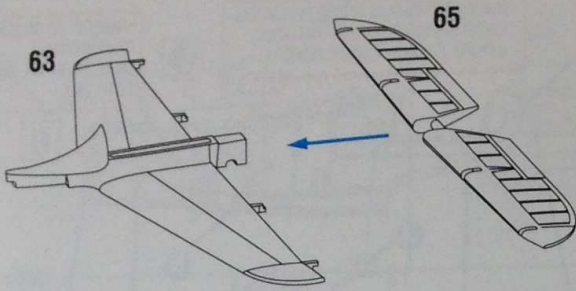

13

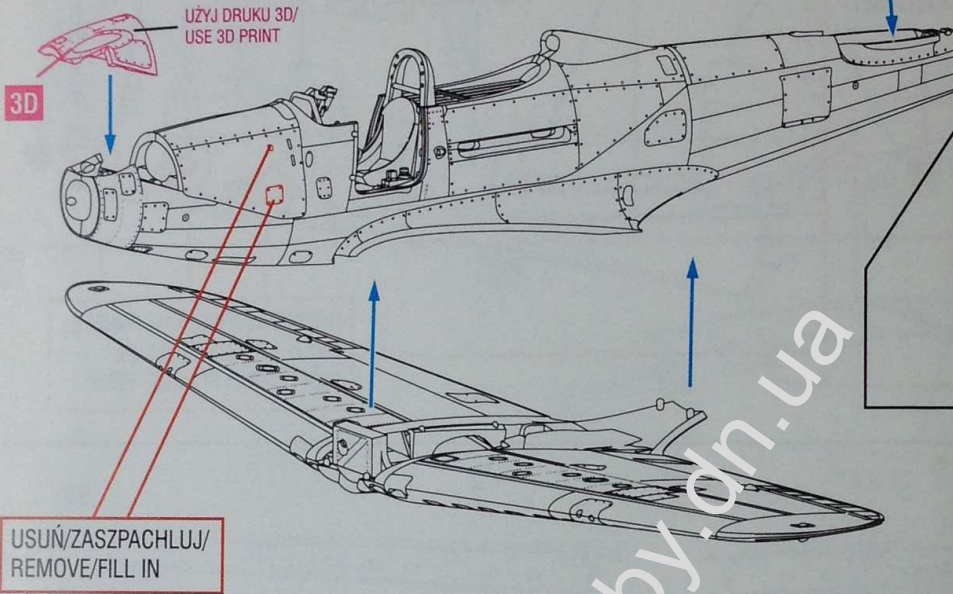

14

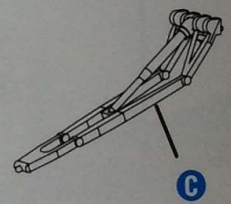
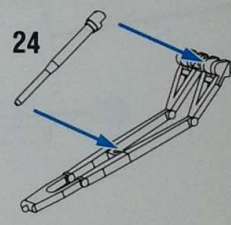

15

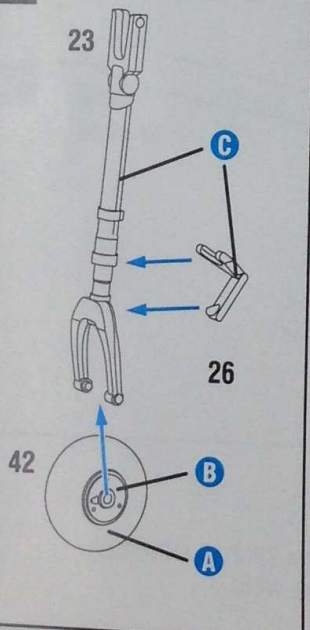

16

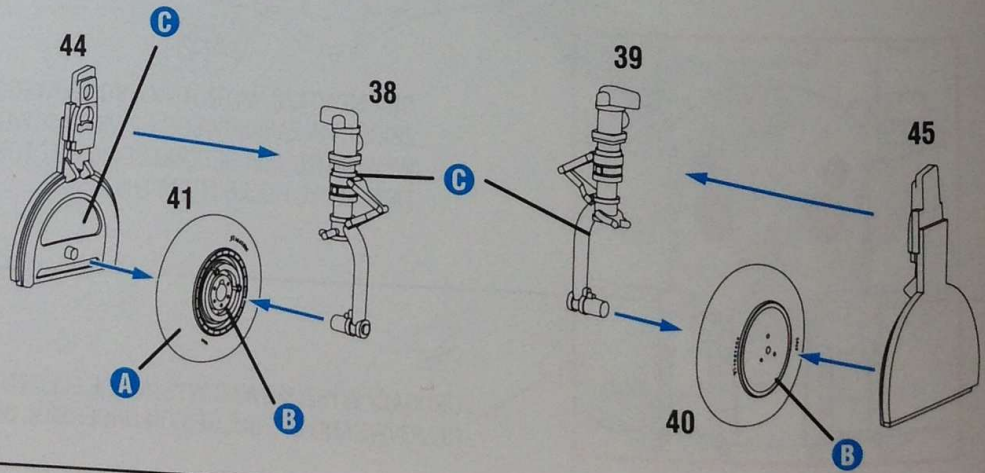

17

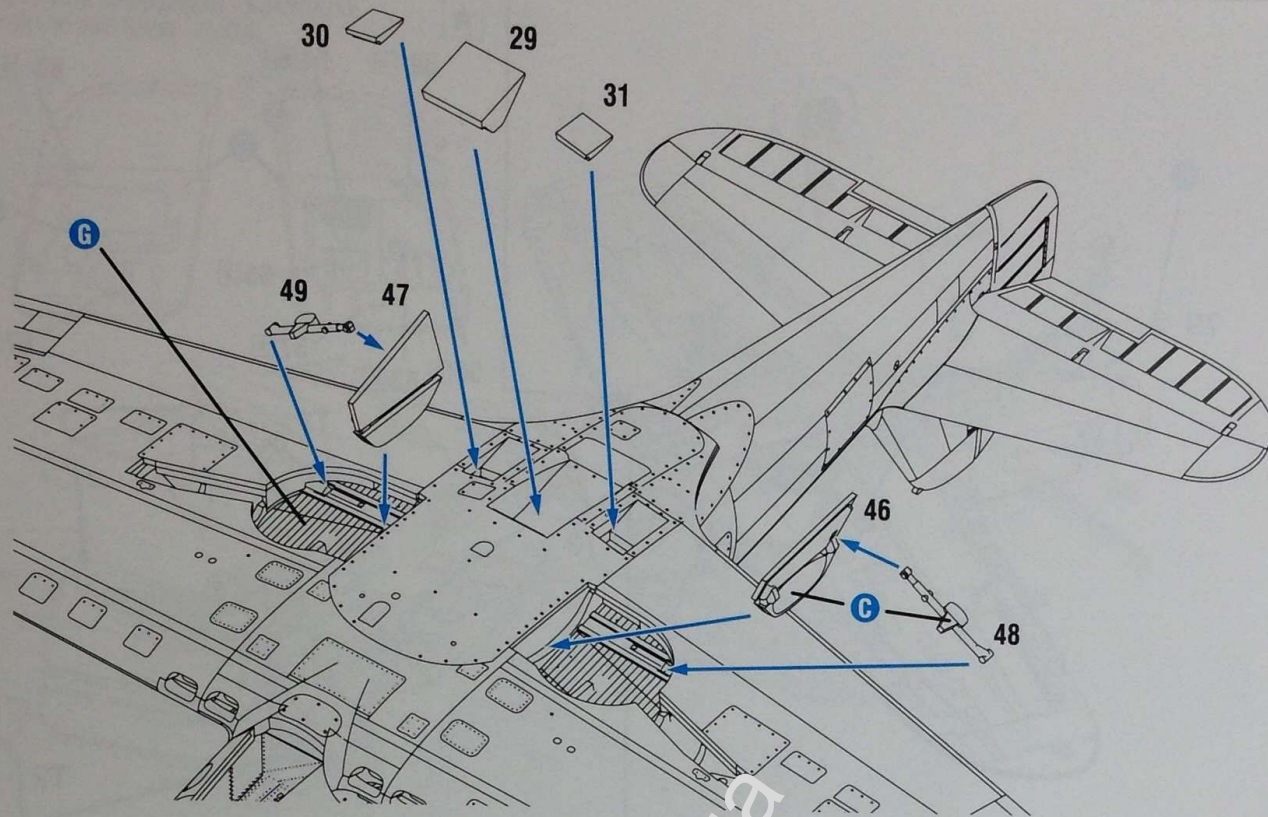

18

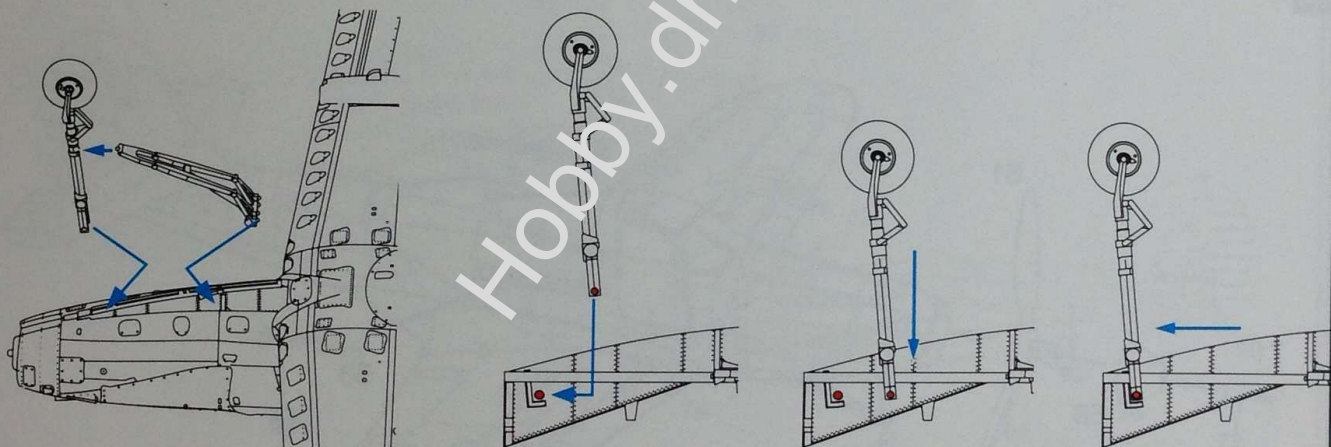

19

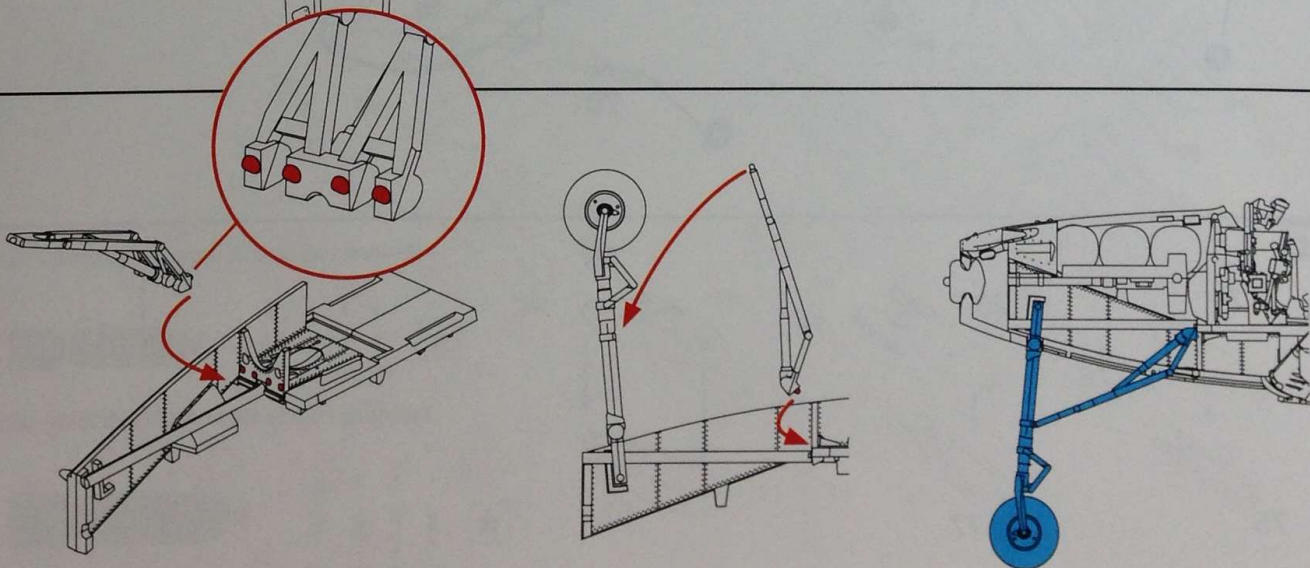

20

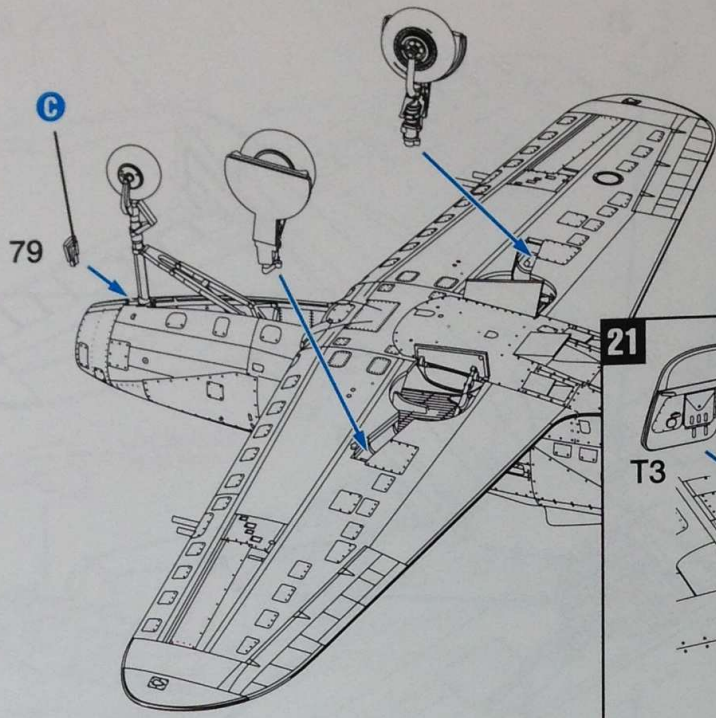

KALKOMANIE - WEWNĘTRZNA STRONA DRZWI /
DECALS - INNER SIDE OF THE DOOR

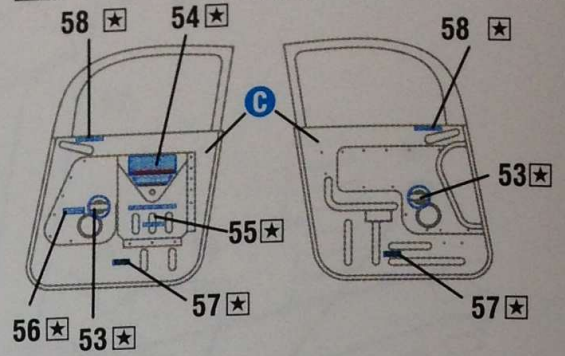

21

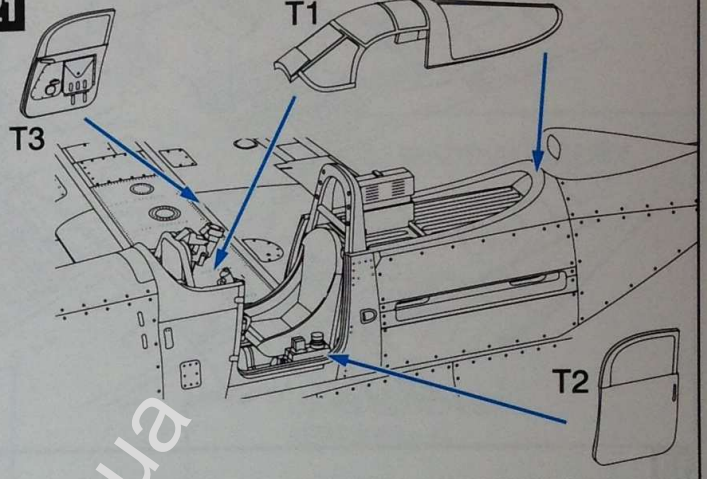

22

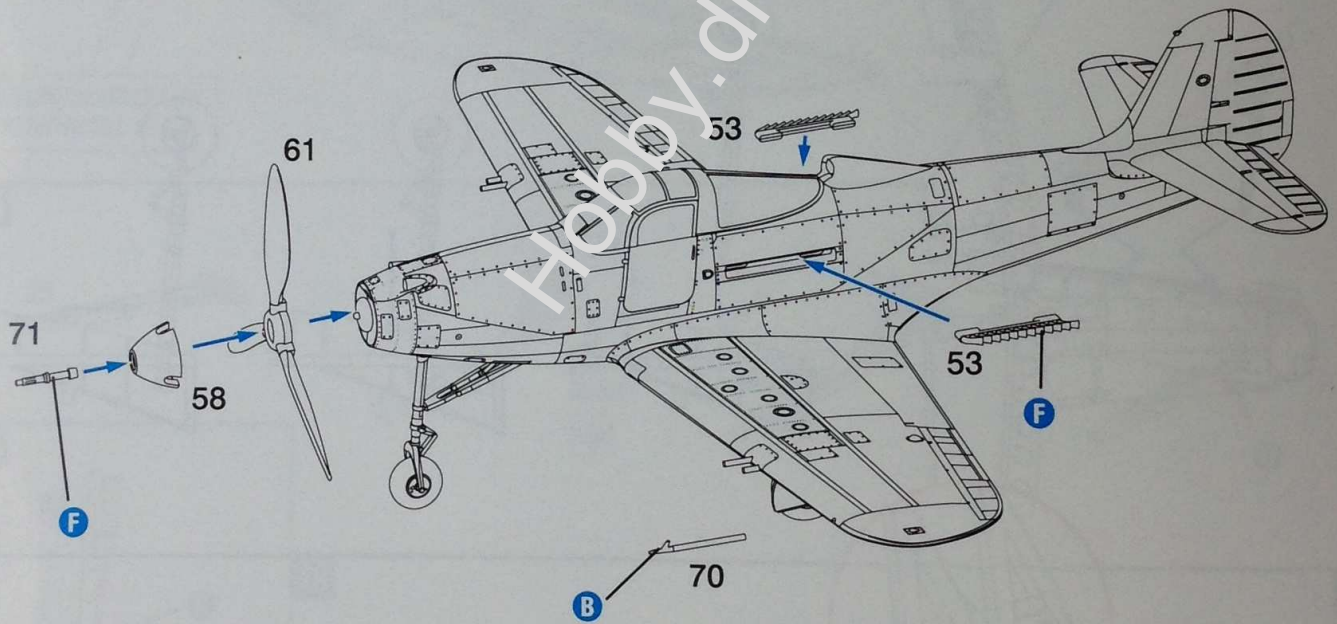

23

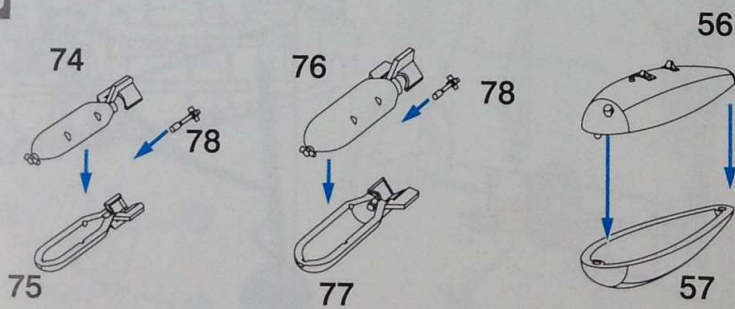

Kalkomanie - bomba 250 funtów/250 Lb bomb - decals

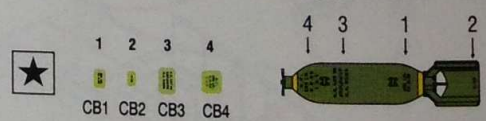

Kalkomanie - bomba 500 funtów/500 Lb bomb - decals

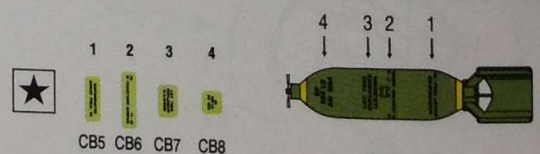

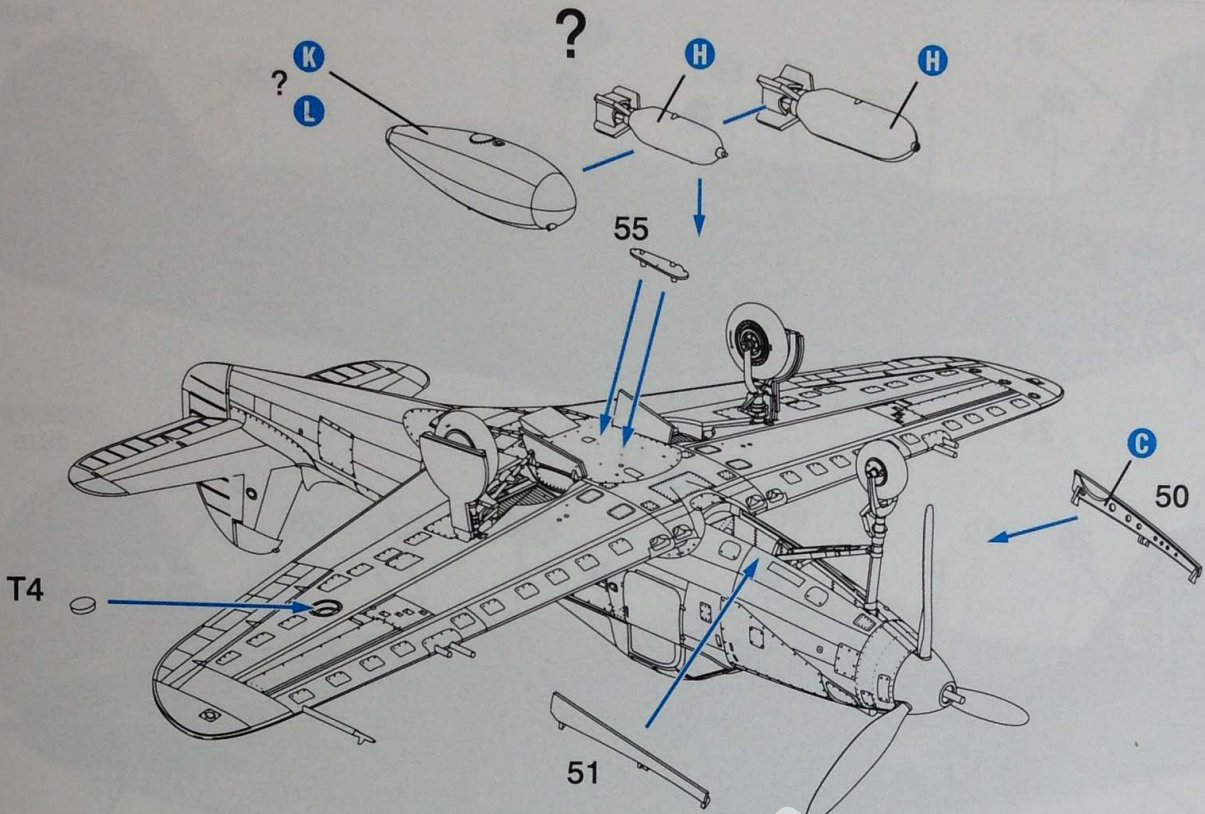

NAPISY EKSPLOATACYJNE/STENCILS

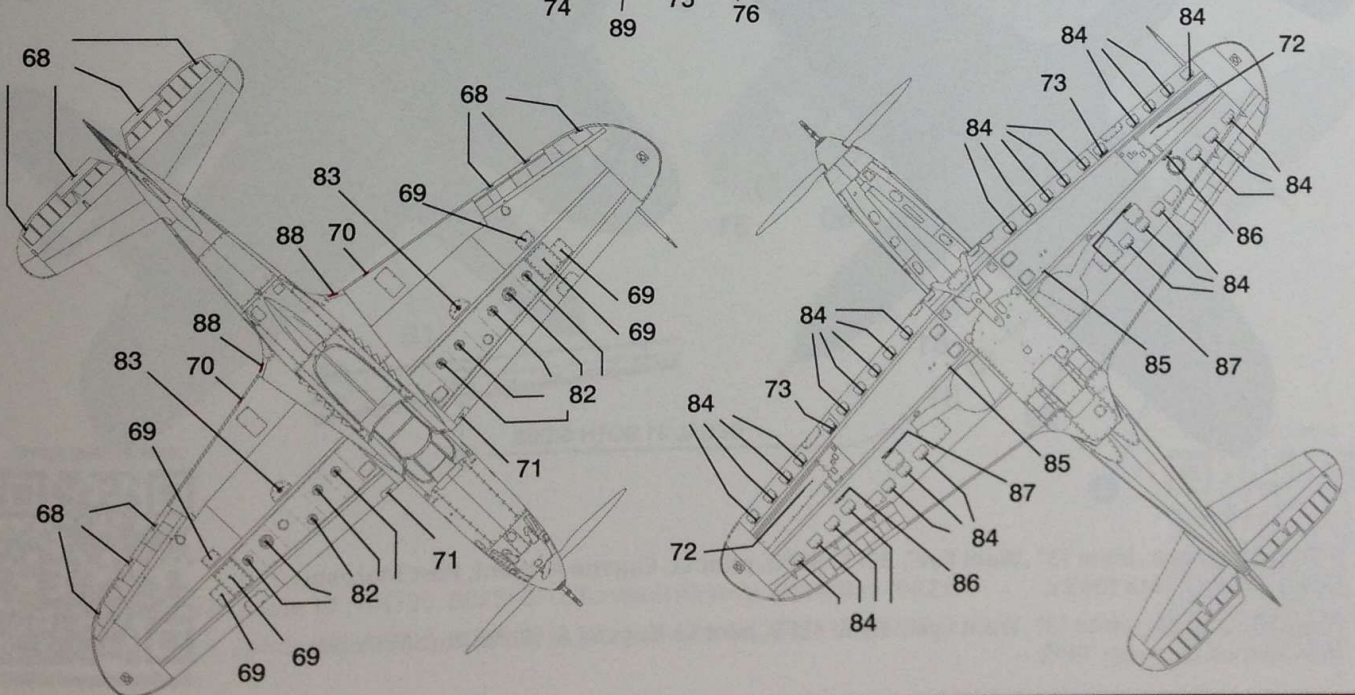
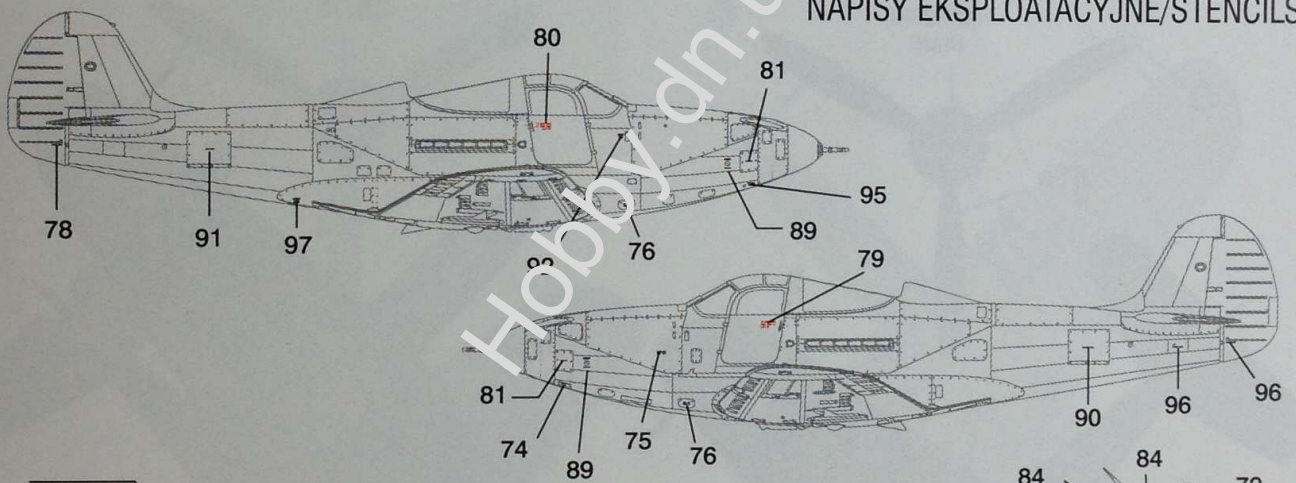

1.

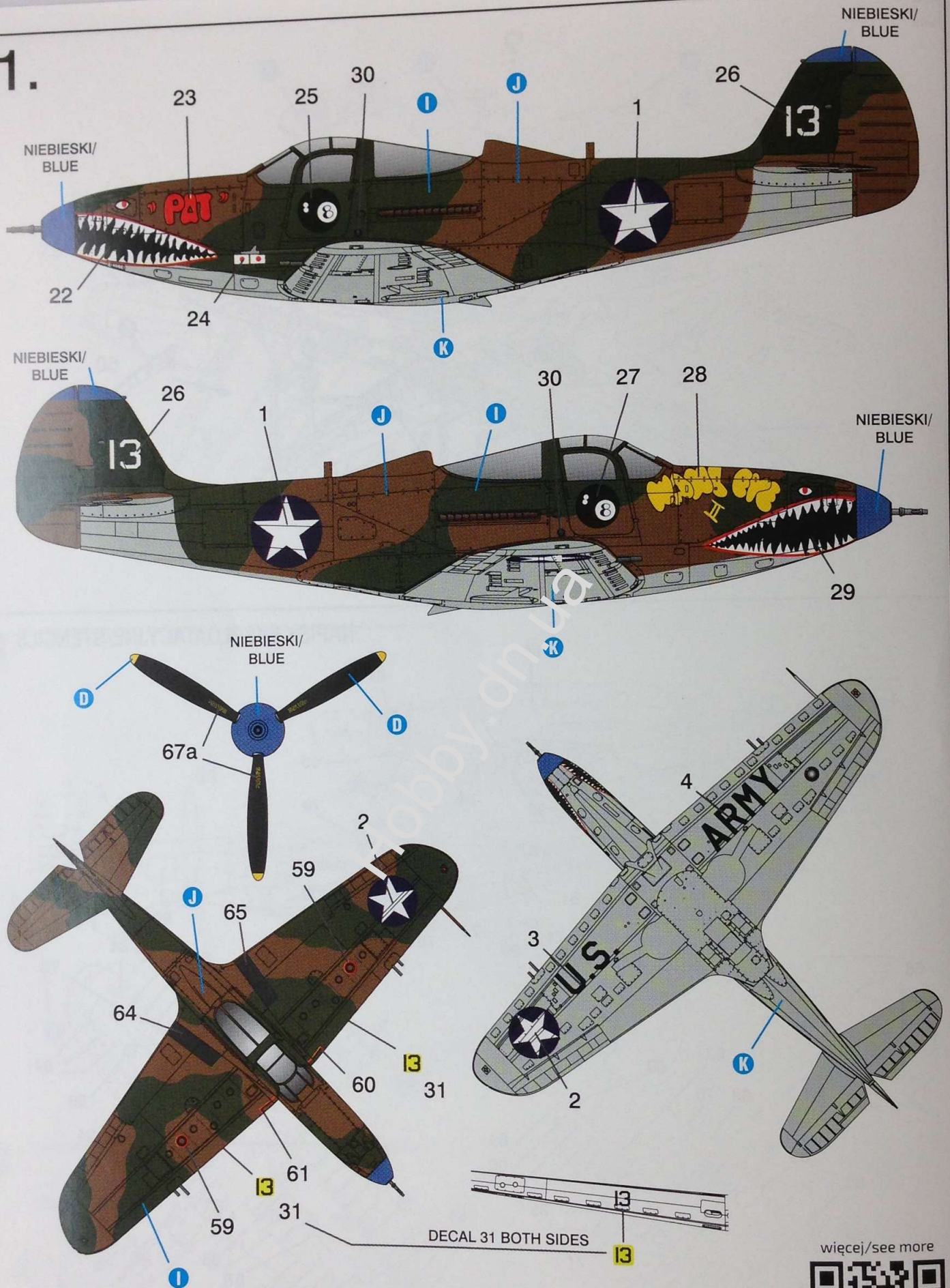

P-400 Airacobra „białe 13” „Wahl Eye”, 39FS/35FG, pilot Lt. Eugene A. Wahl, Port Moresby, Nowa Gwinea, lato 1942 r.

P-400 Airacobra „white 13” „Wahl Eye”, 39FS/35FG, pilot Lt. Eugene A. Wahl, Port Moresby, New Guinea, Summer 1942

więcej/see more



<http://armahobbynews.pl/70057>

2.

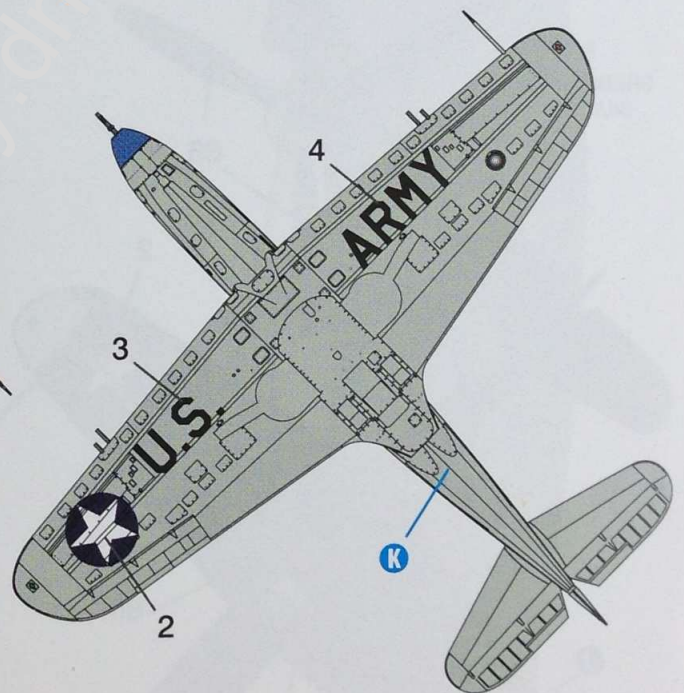
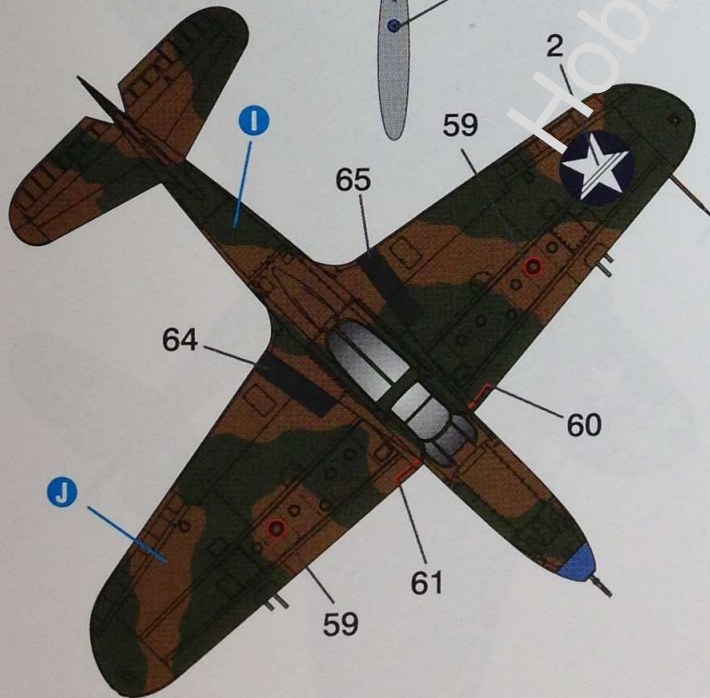
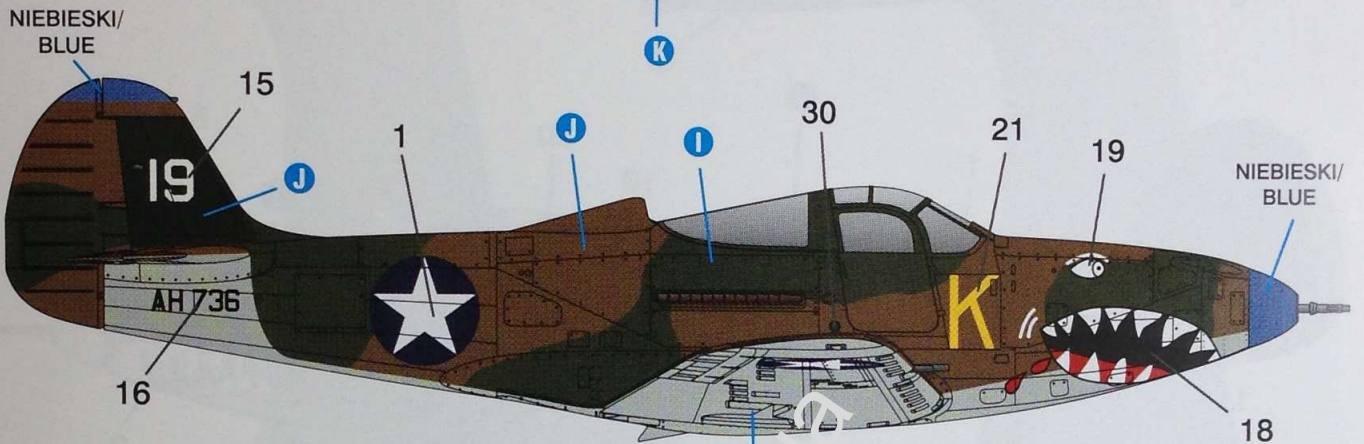
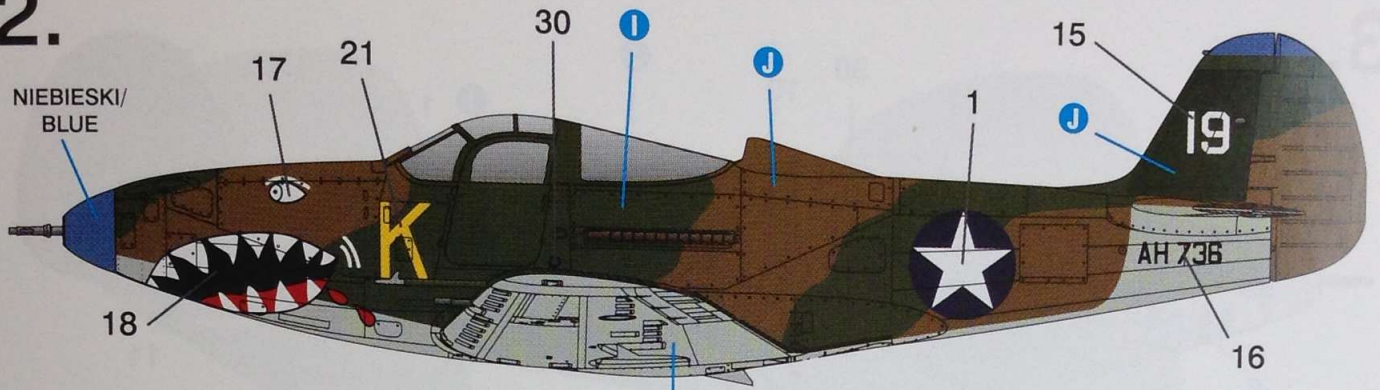

więcej/see more



<http://armahobbynews.pl/70057>

P-400 Airacobra „białe 19”, AH736, 80FS/8FG, Turnbull Airstrip, Milne Bay 1942 r.
P-400 Airacobra „white 19”, AH736, 80FS/8FG, Turnbull Airstrip, Milne Bay 1942

3.

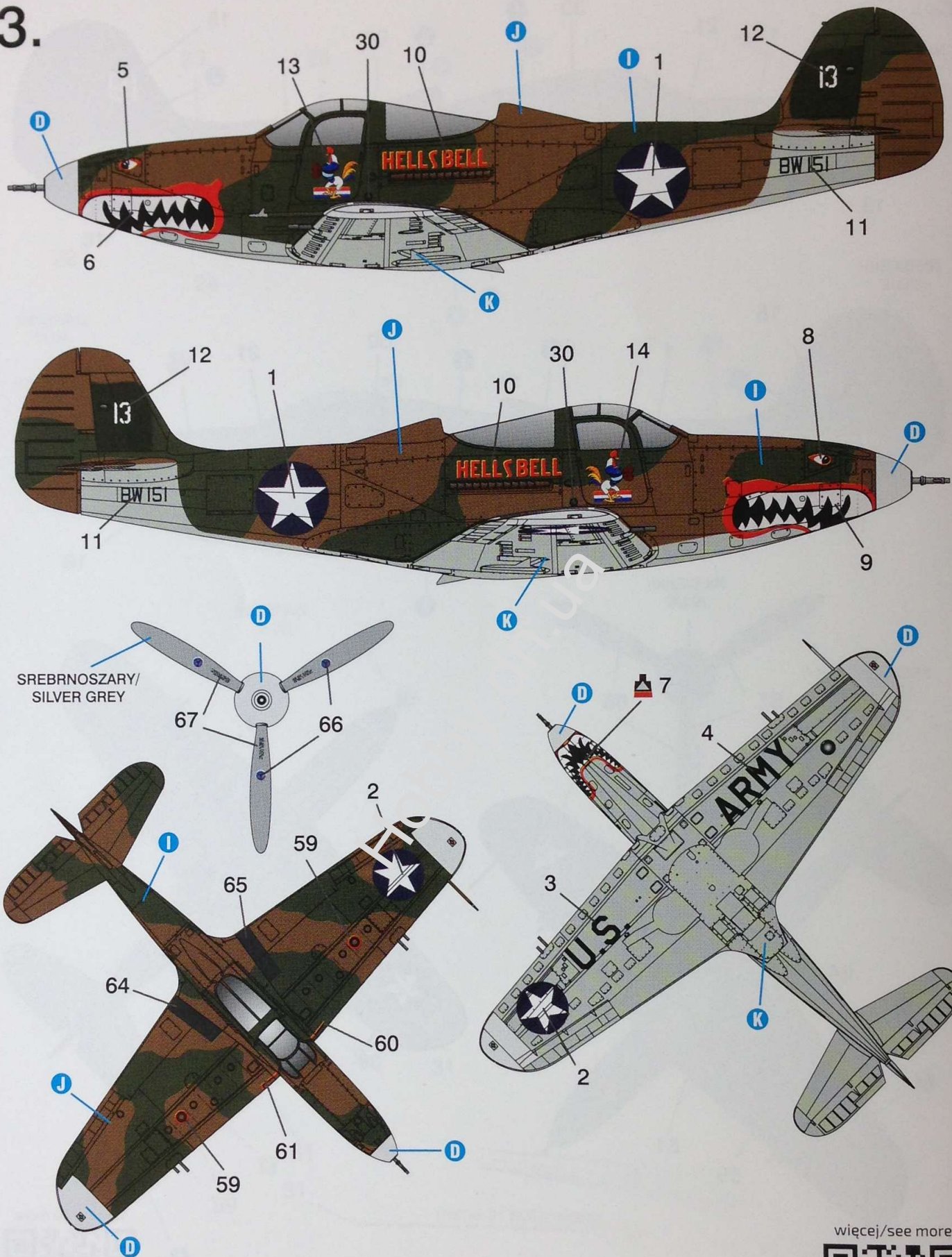

P-40 Airacobra „białe 13” „Hells Bell”, BW151, 67FS/347FG, pilot Lt. Robert M. Ferguson, Guadalcanal, sierpień-listopad 1942 r.

P-40 Airacobra „white 13” „Hells Bell”, BW151, 67FS/347FG, pilot Lt. Robert M. Ferguson, Guadalcanal, August-November 1942.

więcej/see more



<http://armahobbynews.pl/70057>



Hobby.dn.ua

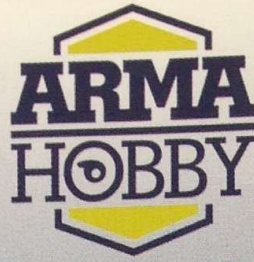

NAKAJIMA
KI-84 HAYATE
70053

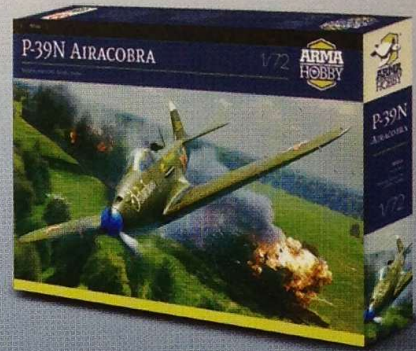

P-39Q
AIRACOBRA
70056

ENJOY MORE 1/72 SCALE FIGHTERS FROM ARMA HOBBY



P-51B
MUSTANG™
70067



SEA HURRICANE MK IIC



Contains plastic kit,
3D parts, decals, masks.

P-400 AIRACOBRA

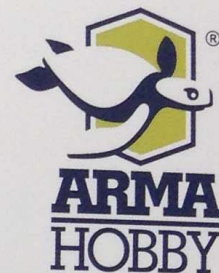

70057



P-400 Airacobra „białe 13” „Wahl Eye”, 39FS/35FG, pilot Lt. Eugene A. Wahl, Port Moresby, Nowa Gwinea, lato 1942 r.
P-400 Airacobra „white 13” „Wahl Eye”, 39FS/35FG, pilot Lt. Eugene A. Wahl, Port Moresby, New Guinea, Summer 1942

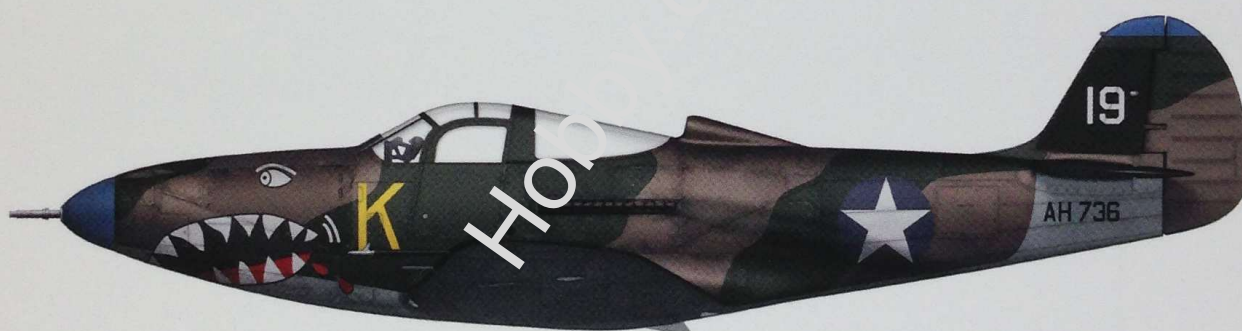

P-400 Airacobra „białe 19”, AH736, 80FS/8FG, Turnbull Airstrip, Milne Bay 1942 r.
P-400 Airacobra „white 19”, AH736, 80FS/8FG, Turnbull Airstrip, Milne Bay 1942



P-400 Airacobra „białe 13” „Hells Bell”, BW151, 67FS/347FG, pilot Lt. Robert M. Ferguson, Guadalcanal, sierpień-listopad 1942 r.
P-400 Airacobra „white 13” „Hells Bell”, BW151, 67FS/347FG, pilot Lt. Robert M. Ferguson, Guadalcanal, August-November 1942.