

### Uwaga!

Przed rozpoczęciem pracy dokładnie przeczytaj instrukcję. Zachowaj zasady bezpieczeństwa przy pracy z łatwopalnym klejem i farbami! Trzymaj model z dala od małych dzieci. Nie pozwalaj im brać do ust/nosa części plastikowych lub naciągać na głowę torebek plastikowych!

**Wsparcie klienta:** W przypadku jakichkolwiek problemów z modelem bez wahania wypełnij formularz zgłoszenia na stronie:

<http://www.armahobby.pl/webpage/wsparcie-faq.html>

### Warning!

Before you start, please read the instructions carefully. Working with flammable glue and/or paint: please follow the safety recommendation of the manufacturers. Keep out of reach of small children! Do not allow them to place plastic parts in their mouths or noses or to pull plastic bags over their heads.

**Customer care:** In case of any problems with the model, please do not hesitate to contact us and fill the claim form on our website:

<http://www.armahobby.com/webpage/wsparcie-faq.html>

Przystępując do II wojny światowej, brytyjskie lotnictwo pokładowe nie dysponowało ani jednym nowoczesnym myśliwcem. W awaryjnej sytuacji postawiono więc na zaokrętowanie Hurricanów, maszyn solidnych i sprawdzonych. Pierwsze „Huragany”, jeszcze w wersji lądowej, wystartowały z pokładu lotniskowca HMS Glorious, który wiosną 1940 r. przewiózł 46. dywizjon RAF do Norwegii, ale był to wyczyn jednorazowy. Kolejną próbą „nawalizacji” Hurricanów były tzw. CAM ships, czyli handlowe statki wyposażone w katapultę do wystrzelenia myśliwca w obronie atakowanego konwoju. Samolot po wykonaniu zadania miał wracać na brzeg lub lądować na wodzie i tonąć. Maszyny te otrzymały oznaczenie Sea Hurricane Mk. Ia i weszły do akcji wiosną 1941 r.

„Prawdziwymi” myśliwcami morskimi stały się samoloty oznaczone Sea Hurricane Mk.Ib. Wyposażono je w sposób typowy dla maszyn pokładowych: hak do lądowania, uchwyty mocowania do katapulty, radio dostosowane do „marynarskich” częstotliwości oraz wyskalowane w węzłach przyrządy. Nie miały jedynie składanych skrzydeł. Wszystkie 340 Sea Hurricane Mk Ib, bo tyle ich powstało, były przebudowane z używanych, „lądowych” Hurricanów Mk.I. Weszły do akcji w lipcu 1941 r. Samoloty te przez ponad rok brały udział w najważniejszych operacjach Royal Navy na Atlantyku, Oceanie Indyjskim, w Arktyce i na Morzu Śródziemnym. Największymi osiągnięciami pochwalić się mogły podczas eskorty dwóch kluczowych, a jakże różnych konwojów – arktycznego PQ-18 (17 zestrzeleń), oraz w operacji „Pedestal” – na Maltę (25 zestrzeleń), latem i jesienią 1942 roku.

At the start of World War II, the Royal Navy's Fleet Air Arm did not have a single modern fighter at its disposal. Given the urgent need, the decision was made to embark Hurricanes, solid and proven machines. The first land-based „Hurris” took off from the aircraft carrier HMS Glorious, which in the spring of 1940 transported No. 46 Squadron RAF to Norway, but at the time it was a one-off feat. Another attempt to navalise Hurricanes were the so-called CAM ships, i.e. merchant ships equipped with a catapult to launch a fighter in defence of an attacked convoy. After completing the task, the plane was supposed to return to shore or land on water and sink. These machines were designated Sea Hurricane Mk. Ia and entered action in the spring of 1941.

The first true naval fighters were the planes designated Sea Hurricane Mk.Ib. They were equipped properly for carrier borne operations: an arrestor hook, catapult spools, a radio with „Navy” frequencies and instruments reading in knots. They only lacked folding wings. All 340 Mk.Ib Sea Hurricanes were converted from used „land” Mk.I Hurricanes. They entered action in July 1941. These planes took part in all the most important Royal Navy operations in the Atlantic, Indian Ocean, Arctic and Mediterranean for over a year. Their greatest achievements occurred during the escort of two very important and very different convoys: PQ-18 in the Arctic (17 kills), and Operation Pedestal to Malta (25 kills), in the summer and fall of 1942.

Podziękowania/Acknowledgement: **Wojciech Łuczak, Tony O'Toole**

### Kalkomanie/Decals

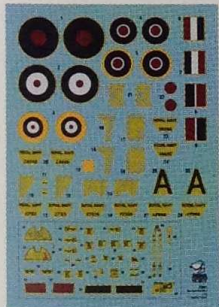

### Części drukowane 3D/3D printed parts

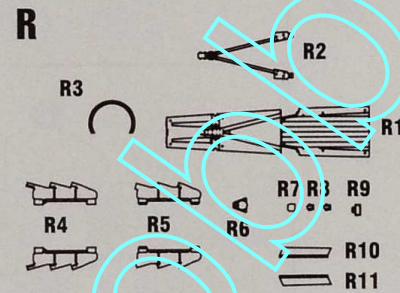

### Części przezroczyste/Clear parts

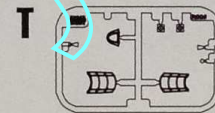

### Maski/Masks

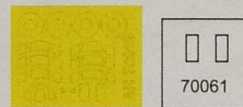

### Części plastikowe/Plastic part

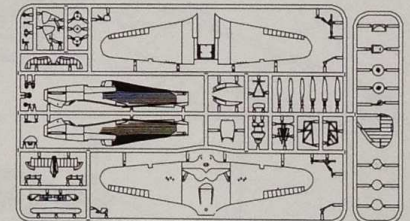

### Panele winylowe/Vinyl panels

Kolory farb/ Paint colours	Hataka	AK RC	Lifecolor	AMMO	Humbrol	Vallejo	Tamiya	Kolory farb/ Paint colours	Hataka	AK RC	Lifecolor	AMMO	Humbrol	Vallejo	Tamiya
<b>A</b> Interior Grey Green FS34226	HTK-A025/ C025	RC293	UA551	219	78	71.305	XF-71	<b>F</b> Sky Type S FS34583	HTK-A026/ C026	RC290	UA095	0243	90	71.302	XF-21
<b>B</b> Night black FS37038	HTK-A041/ C041	RC001	LC02	046	33	71.057	XF-1	<b>G</b> BS Extra Dark Sea Grey	HTK-A140/ C140	RC295	UA109	-	123	71.110	XF-54
<b>C</b> Matt silver FS37178	HTK-A003/ C003	RC020	LC24	194	56	71.062	XF-16	<b>H</b> BS Dark Slate Grey	HTK-A202/ C202	RC294	-	-	224	71.309	-
<b>D</b> GUN METAL	HTK-A106	RC015	LC26	045	53	71.073	XF-10	<b>I</b> Insignia Yellow FS13538	HTK-A066/ C066	RC007	LC04	125	24	71.002	XF-3
<b>E</b> Insignia Red FS11136	HTK-A219/ C219	RC006	LC26*	049*	153	71.102*	X-7*	<b>J</b> Insignia White FS37925	HTK-C049	RC004	LC01	050	34	71.001	XF-2

\*Kolor zbliżony/similar colour

Manufacturer: Arma Hobby S.C.  
Ostrobramska 101/200; 04-041 Warszawa, Poland  
[www.armahobby.pl](http://www.armahobby.pl) [www.armahobby.com](http://www.armahobby.com)  
kontakt1@armahobby.pl  
© 2022 Arma Hobby S.C. all rights reserved



montaż symetryczny/  
symmetrical assembly



zegnij/  
bend



usuń/  
remove



kalkomania/  
decals



nawierć/  
drill



zwin/  
roll

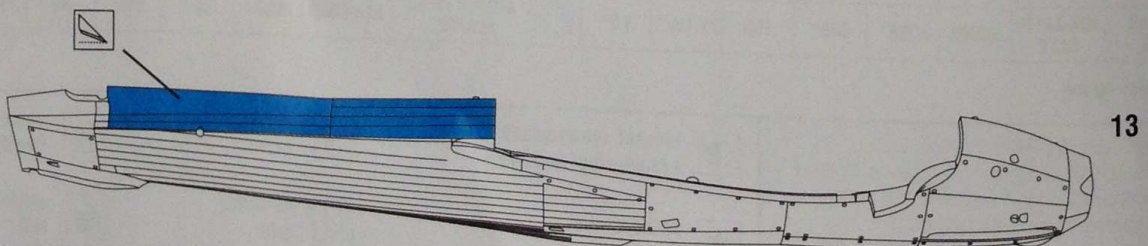
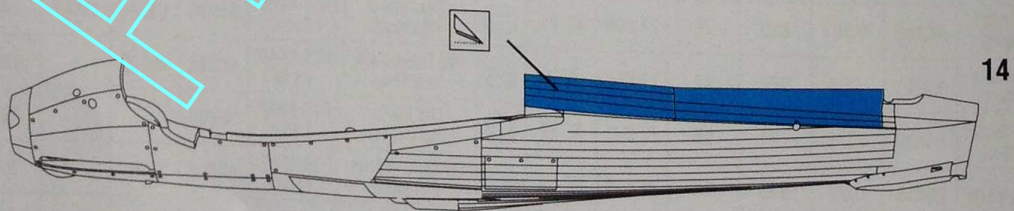
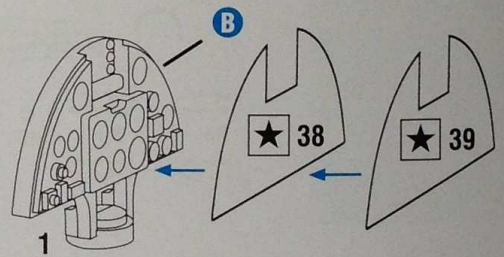
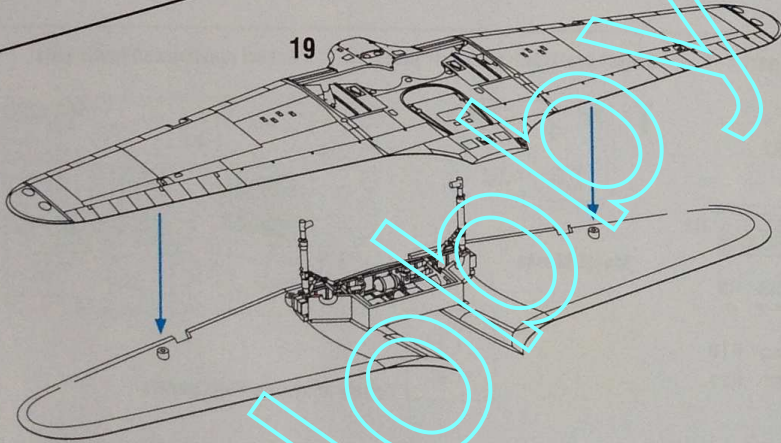
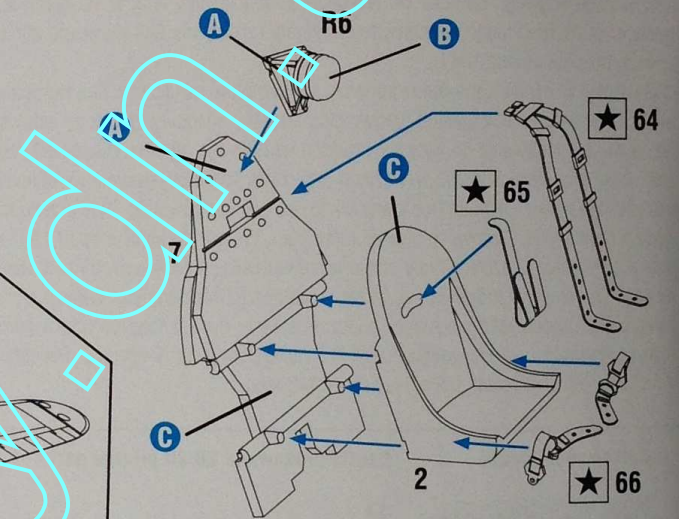
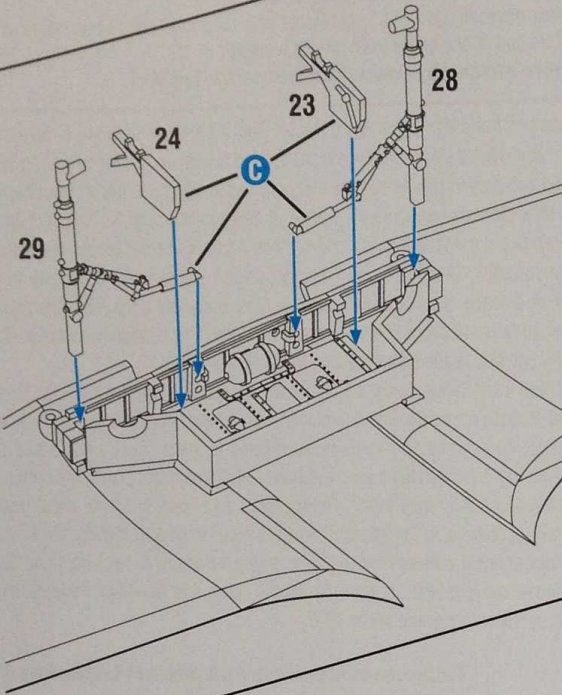
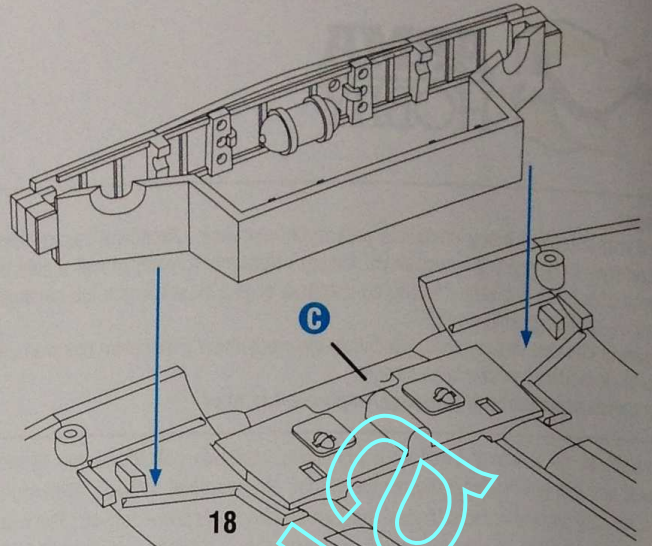
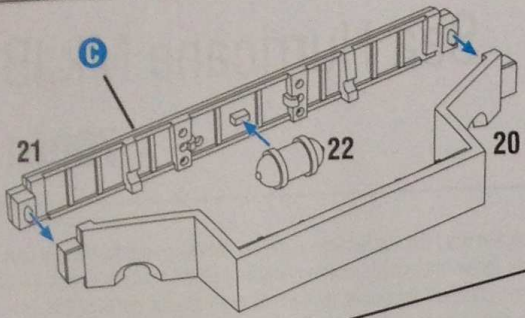

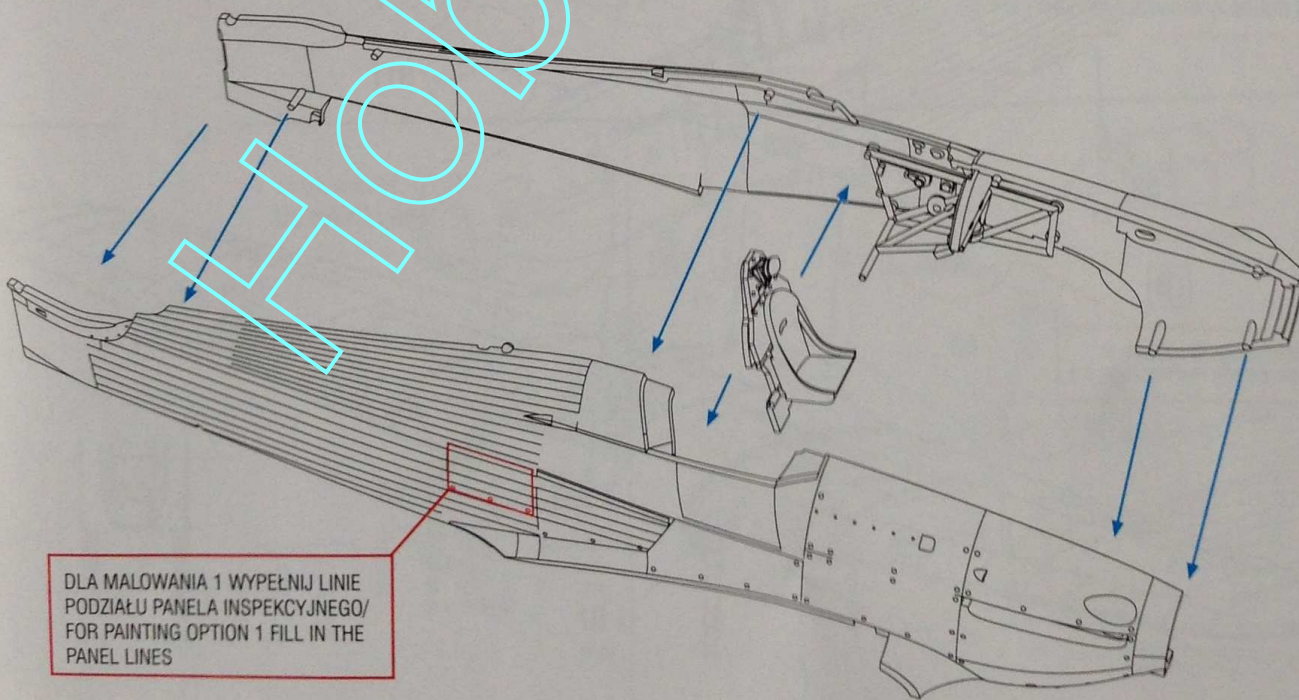
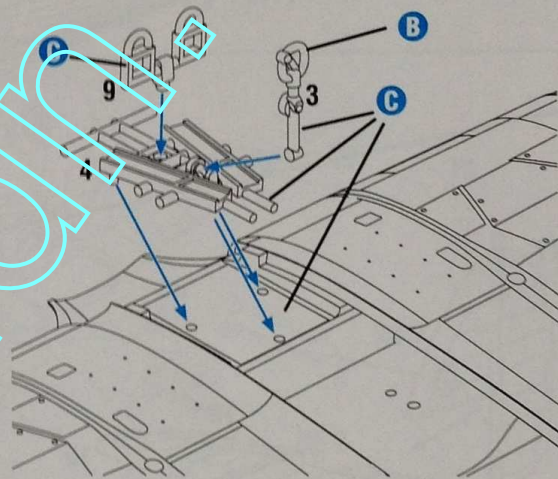
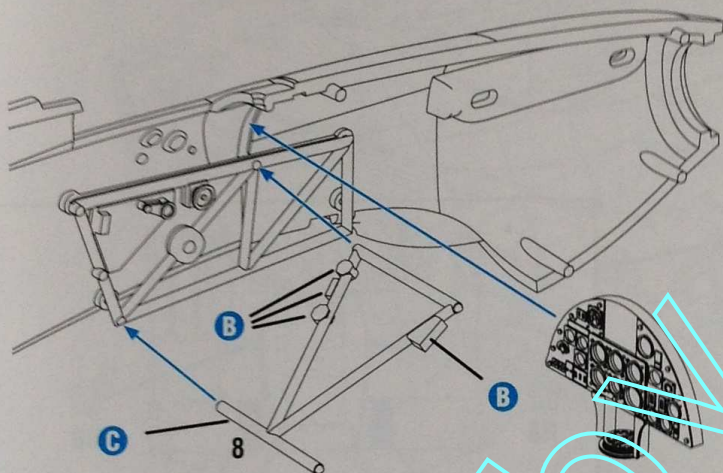
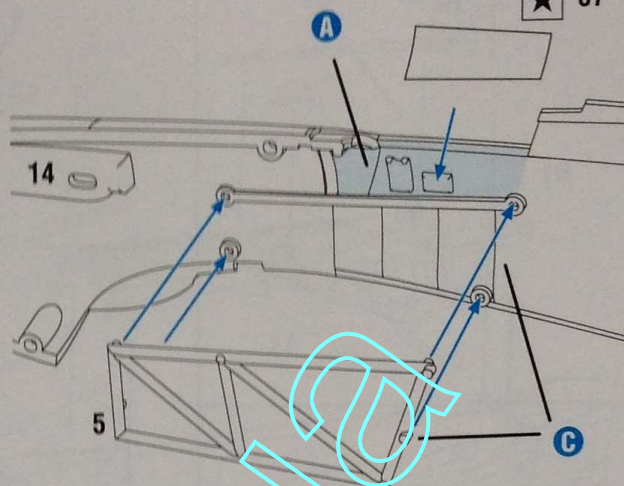
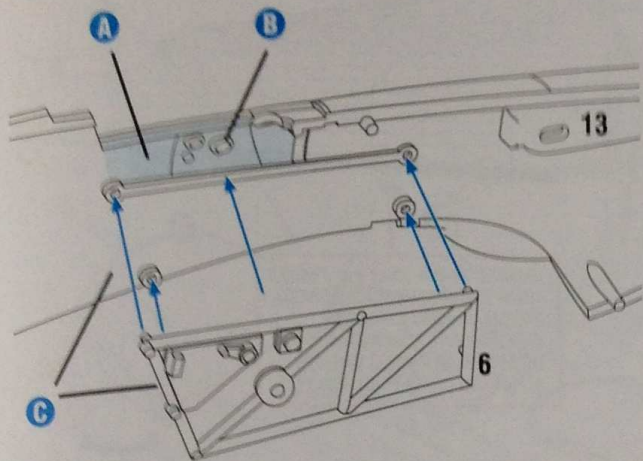

DLA MALOWANIA 1 WYPEŁNIJ LINIE  
PODZIAŁU PANELA INSPEKCYJNEGO/  
FOR PAINTING OPTION 1 FILL IN THE  
PANEL LINES

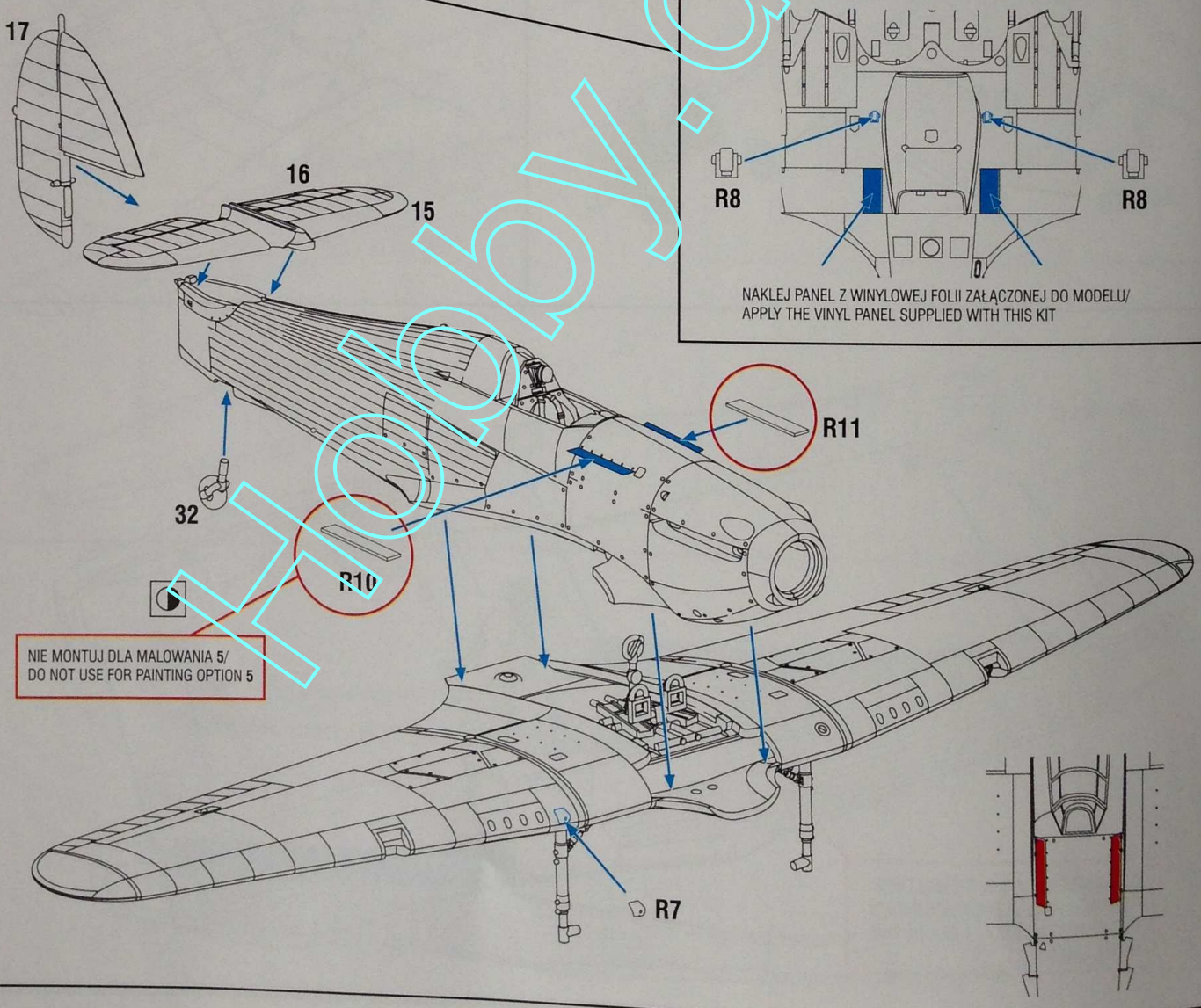
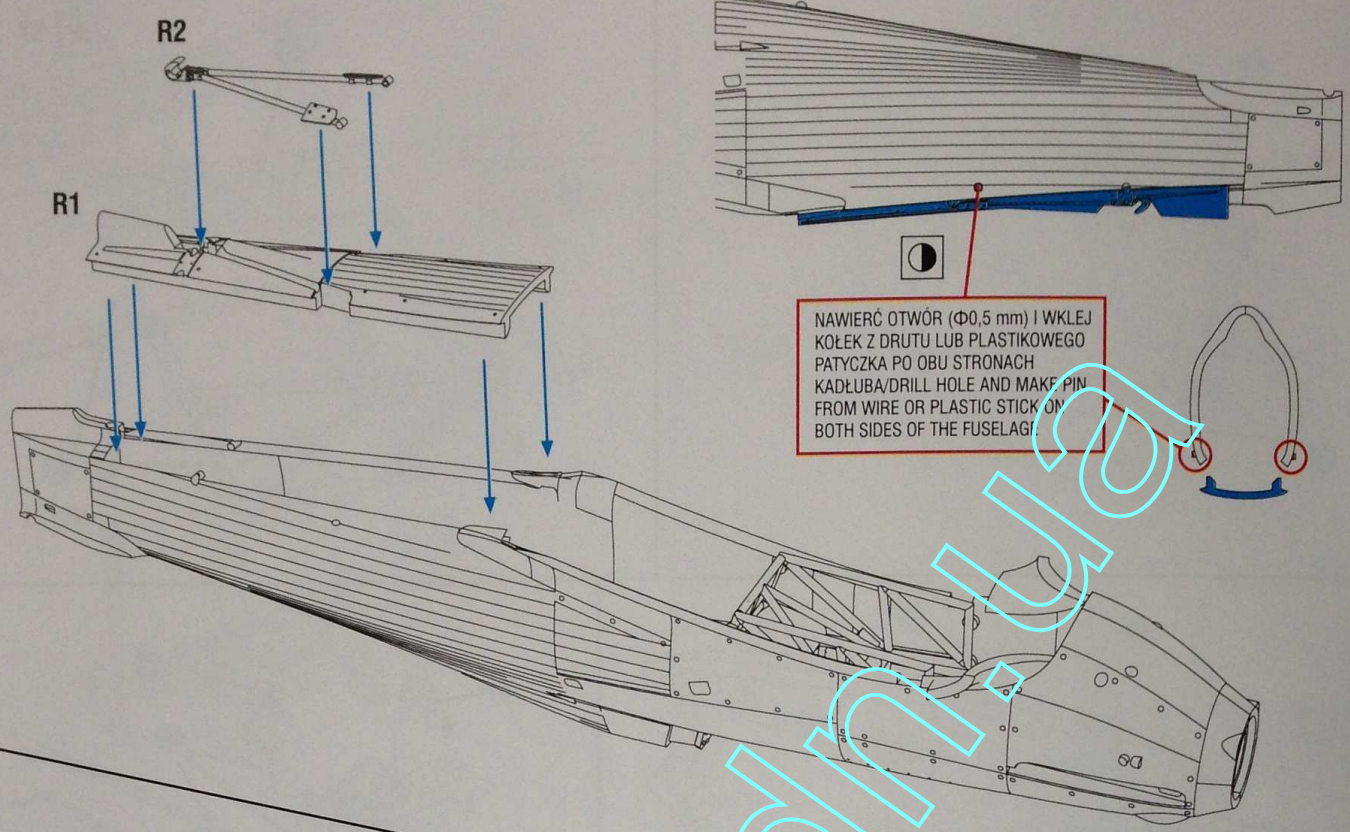

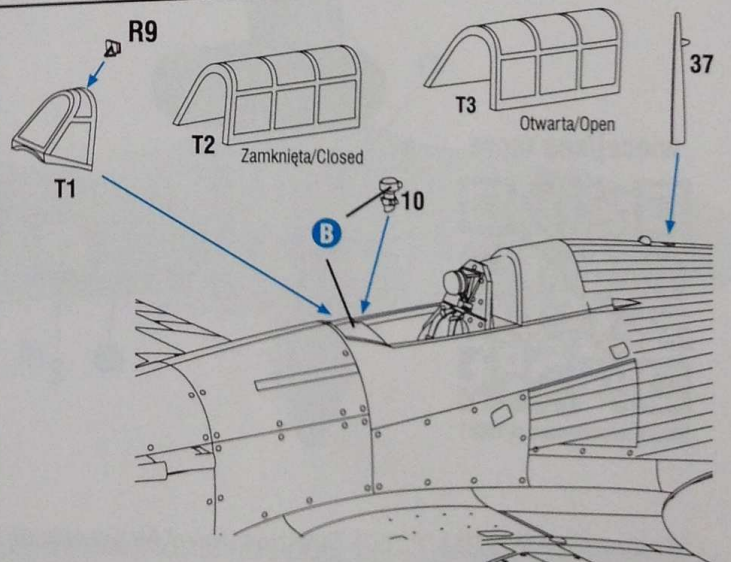
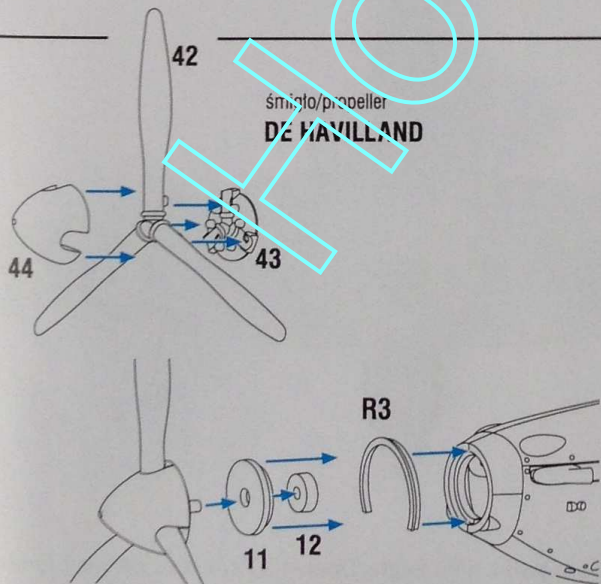
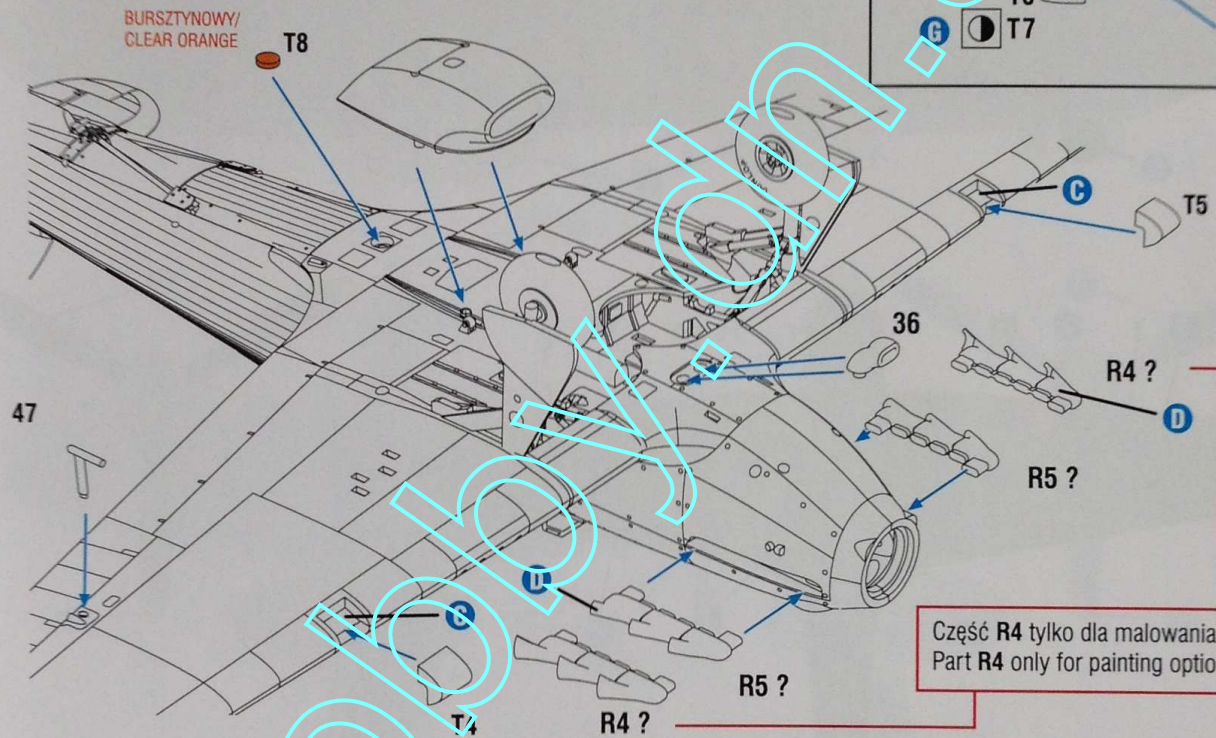
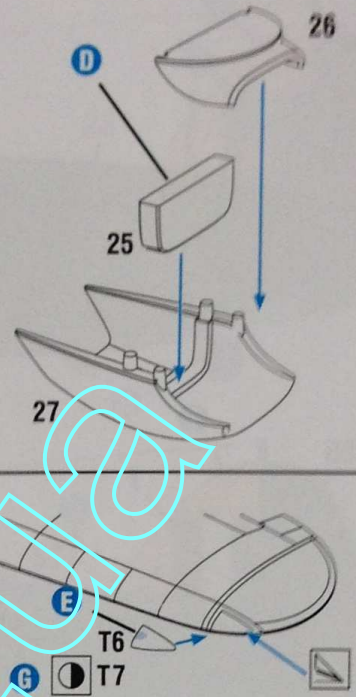
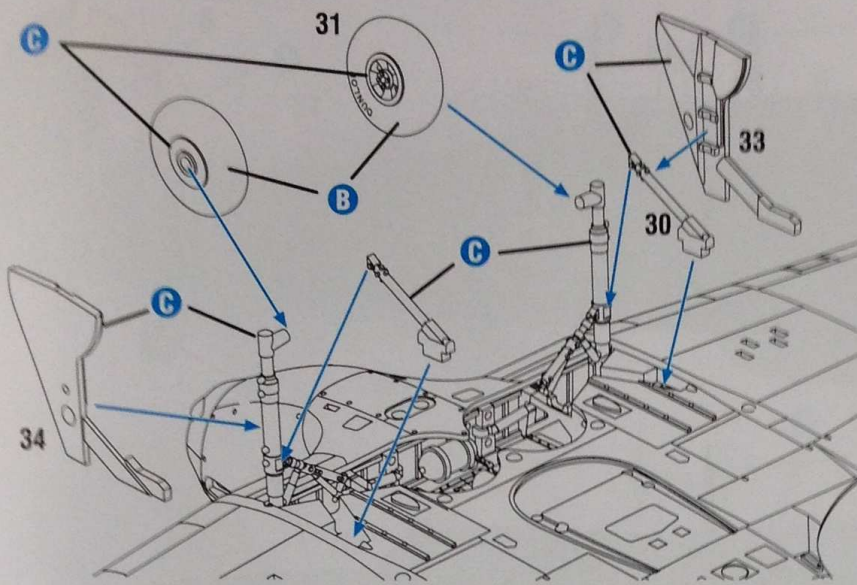

1.

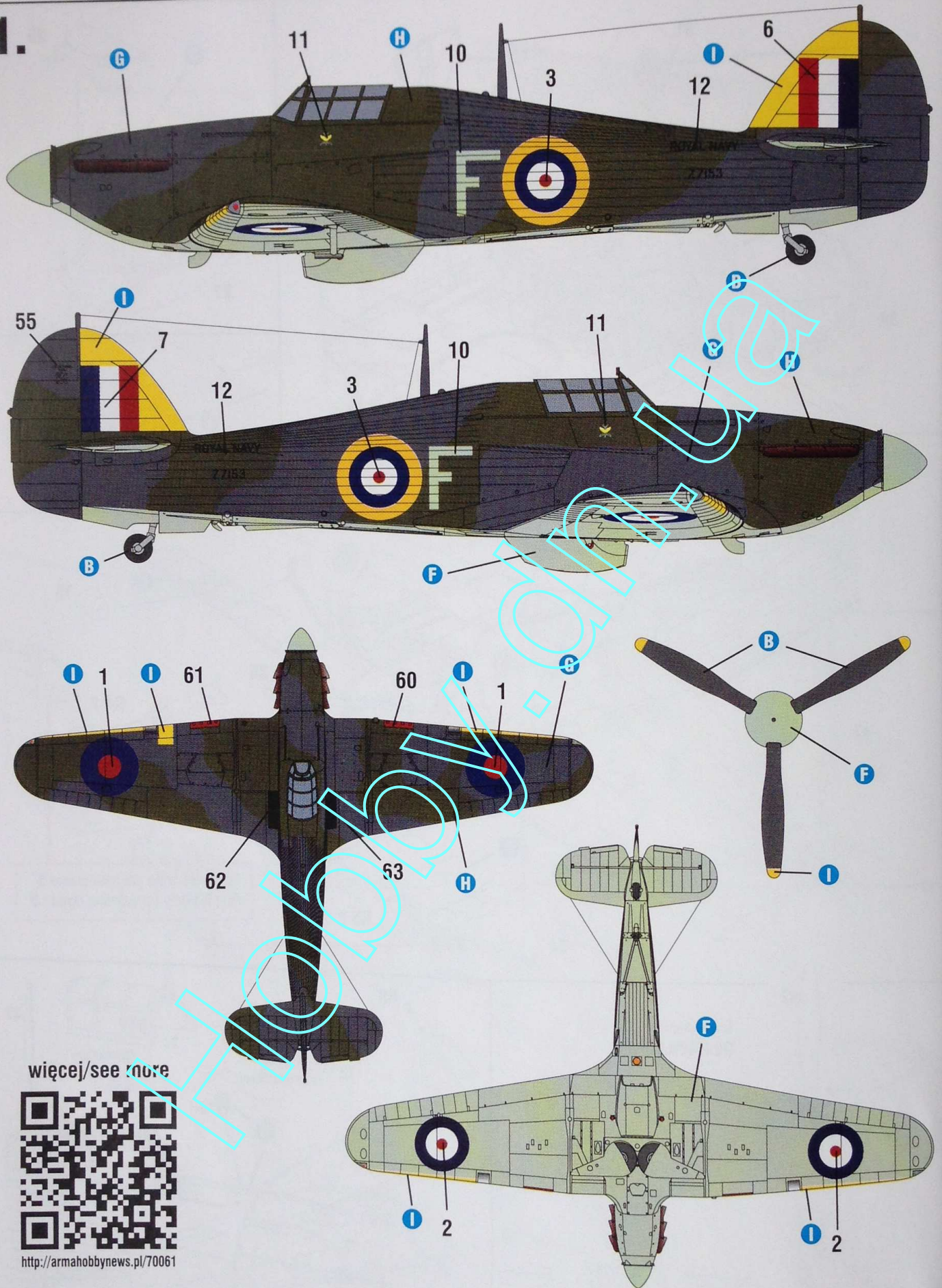

więcej/see more



<http://armahobbynews.pl/70061>

Sea Hurricane IB, Z7153 "F", 801. Dywizjon (Naval Air Squadron), lotniskowiec HMS Eagle, Operacja Pedestal, sierpień 1942 r.  
Sea Hurricane IB, Z7153 "F", No. 801 Naval Air Squadron, aircraft carrier HMS Eagle, Operation Pedestal, August 1942

2.

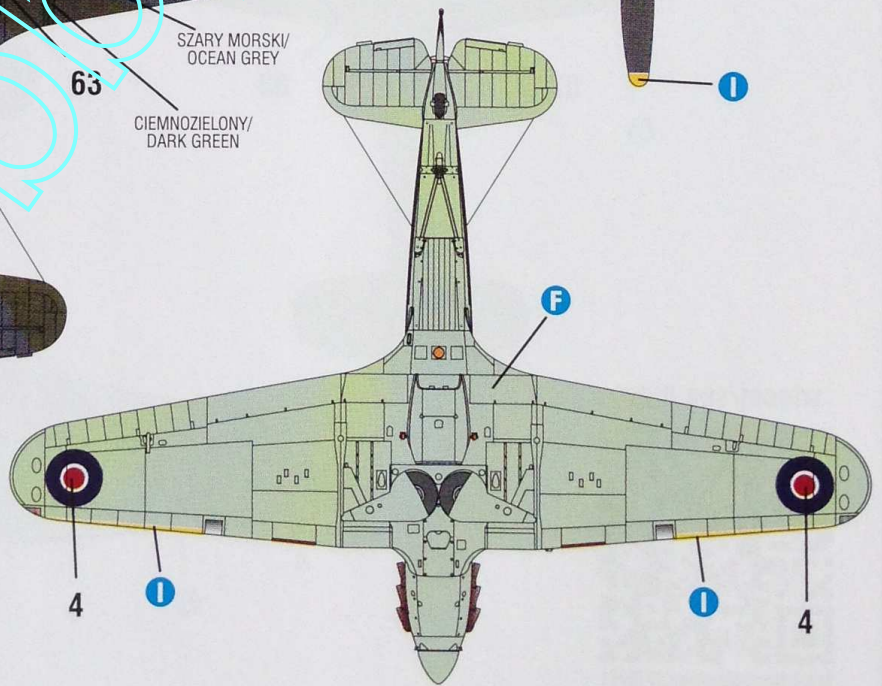
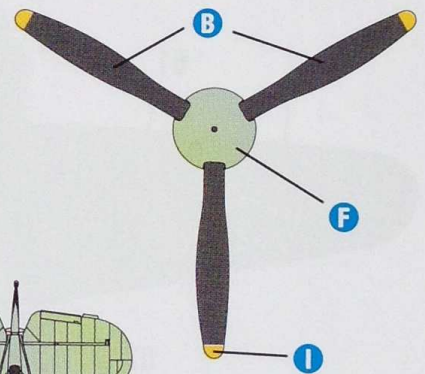
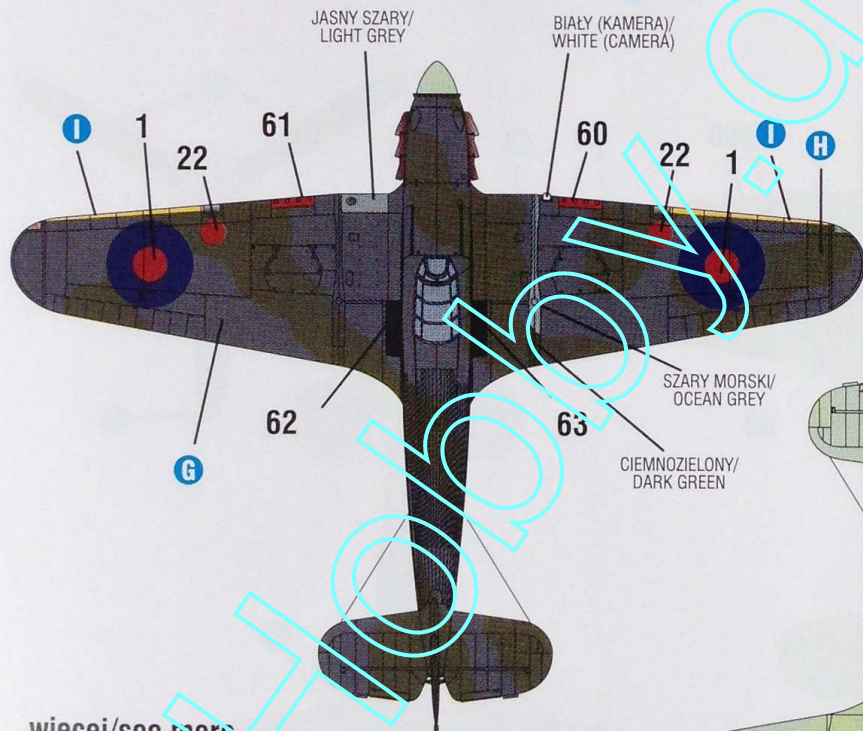
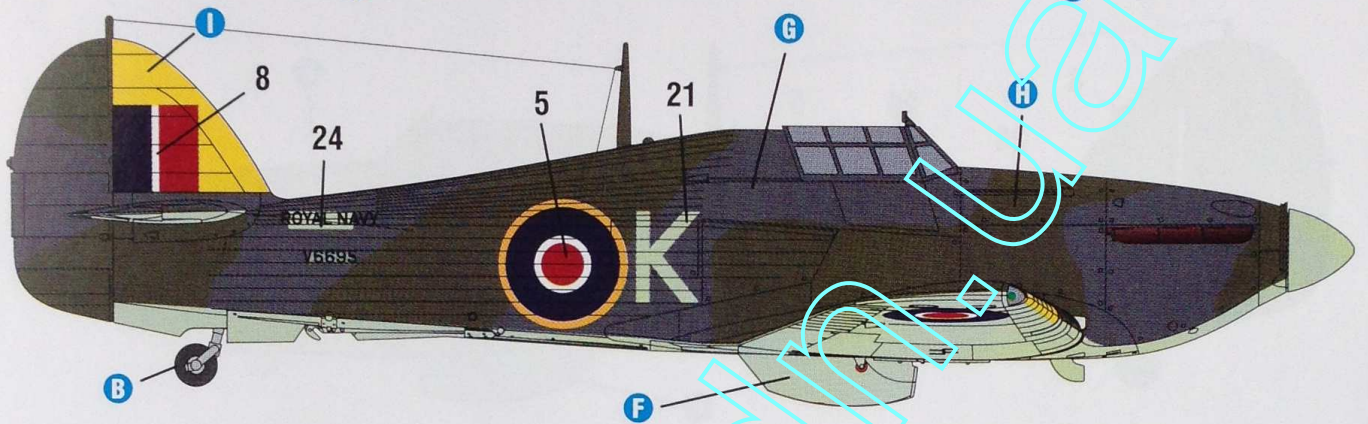
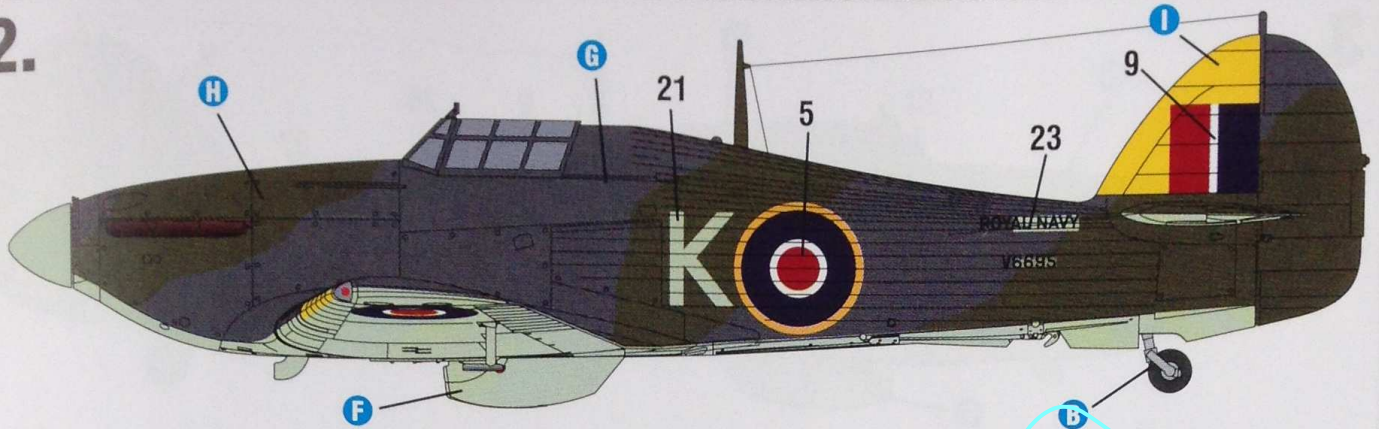

więcej/see more



<http://armahobbynews.pl/70061>

Sea Hurricane IB, V6695 "K", 801. Dywizjon (Naval Air Squadron), lotniskowiec HMS Eagle, Operacja Pedestal, sierpień 1942 r.  
 Sea Hurricane IB, V6695 "K", No. 801 Naval Air Squadron, aircraft carrier HMS Eagle, Operation Pedestal, August 1942

3.

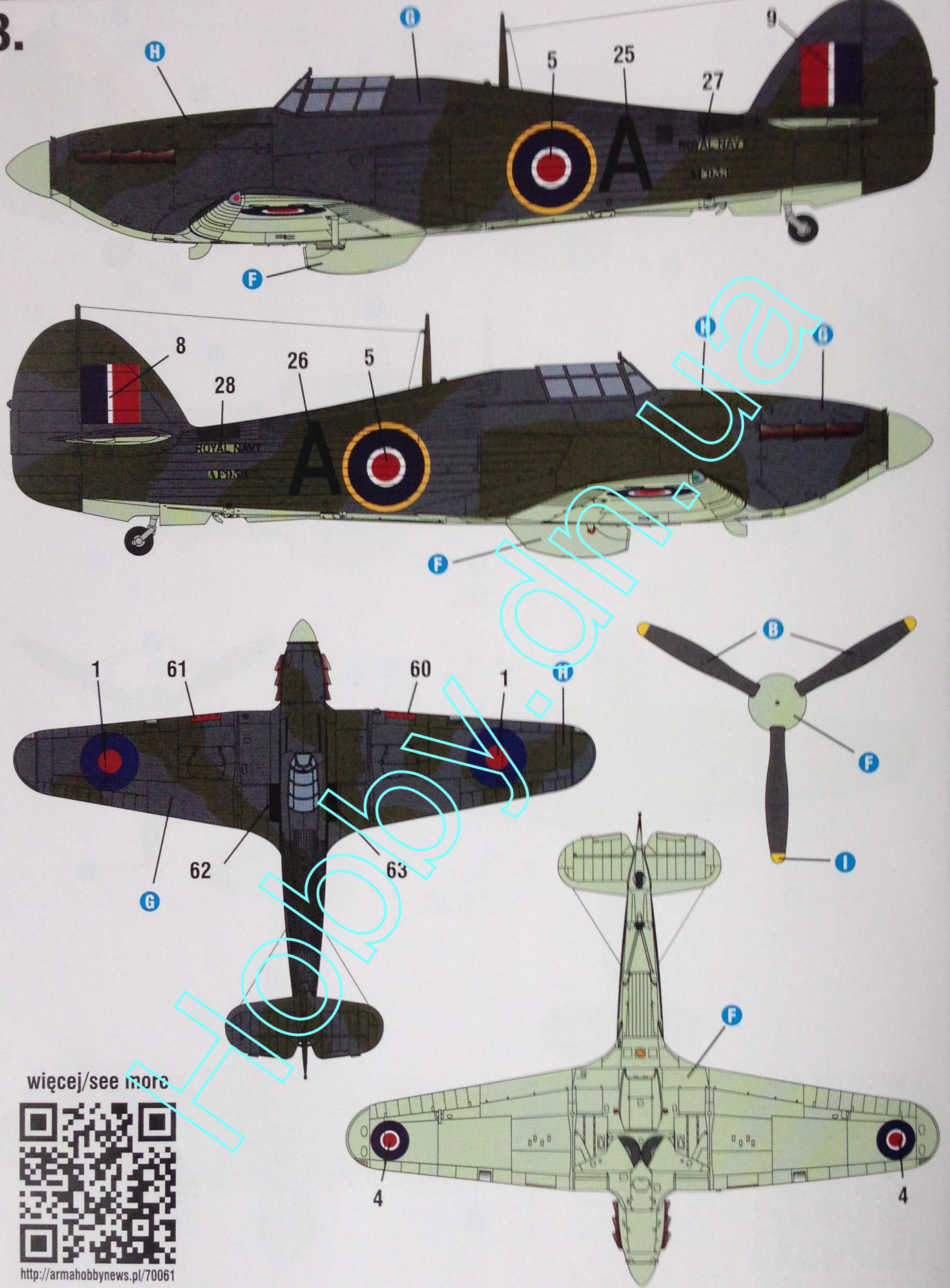

więcej/see more



<http://armahobbynews.pl/70061>

Sea Hurricane IB, AF953 "A", 802. Dywizjon (Naval Air Squadron), lotniskowiec HMS Avenger, lato 1942 r.  
Sea Hurricane IB, AF953 "A", No. 802 Naval Air Squadron, aircraft carrier HMS Avenger, summer 1942



4.

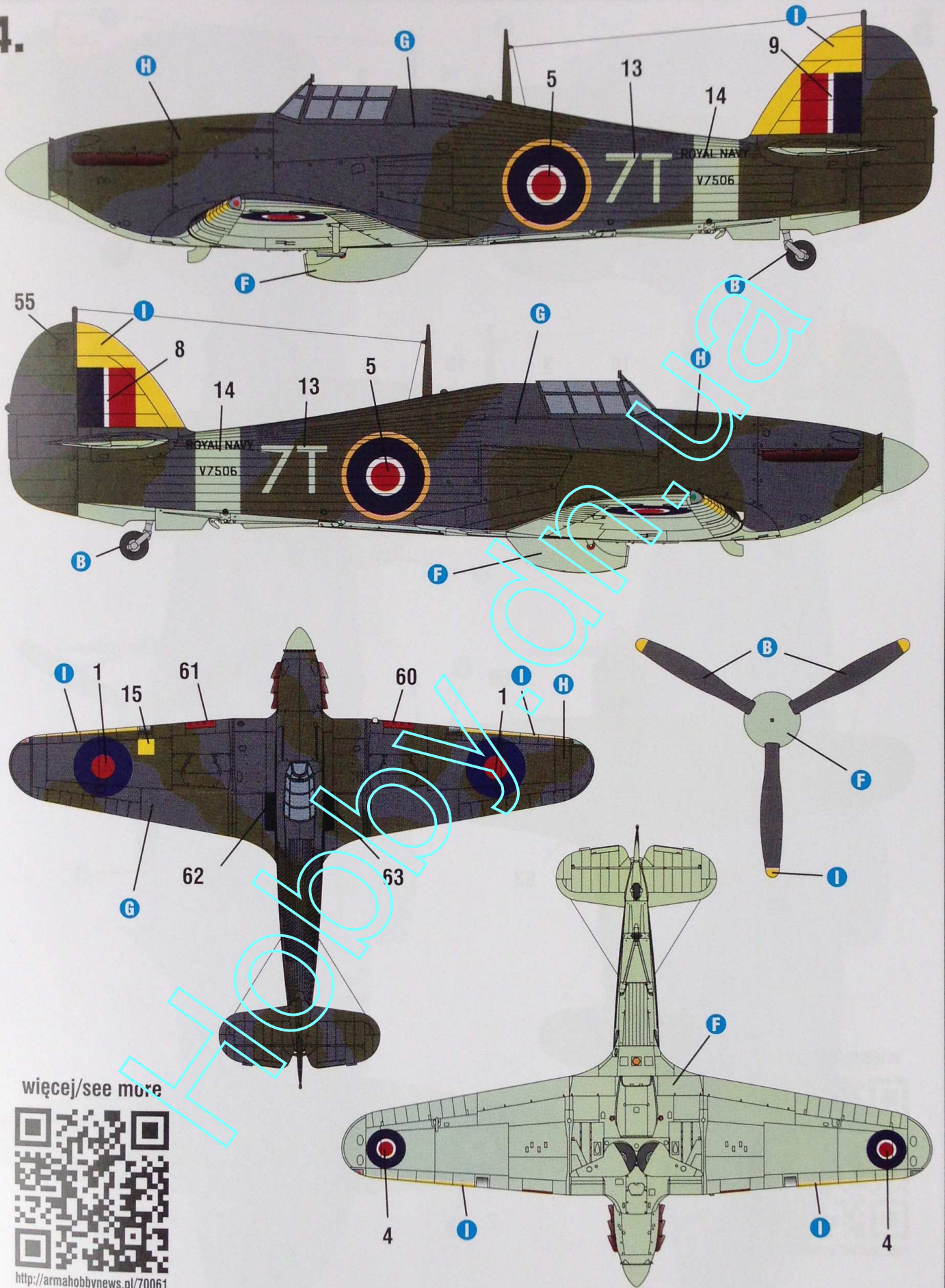

więcej/see more



<http://armahobbynews.pl/70061>

Sea Hurricane IB, V7506 "7T", 885. Dywizjon (Naval Air Squadron), lotniskowiec HMS Victorious, Operacja Pedestal, sierpień 1942 r.  
Sea Hurricane IB, V7506 "7T", No. 885 Naval Air Squadron, aircraft carrier HMS Victorious, Operation Pedestal, August 1942

5.

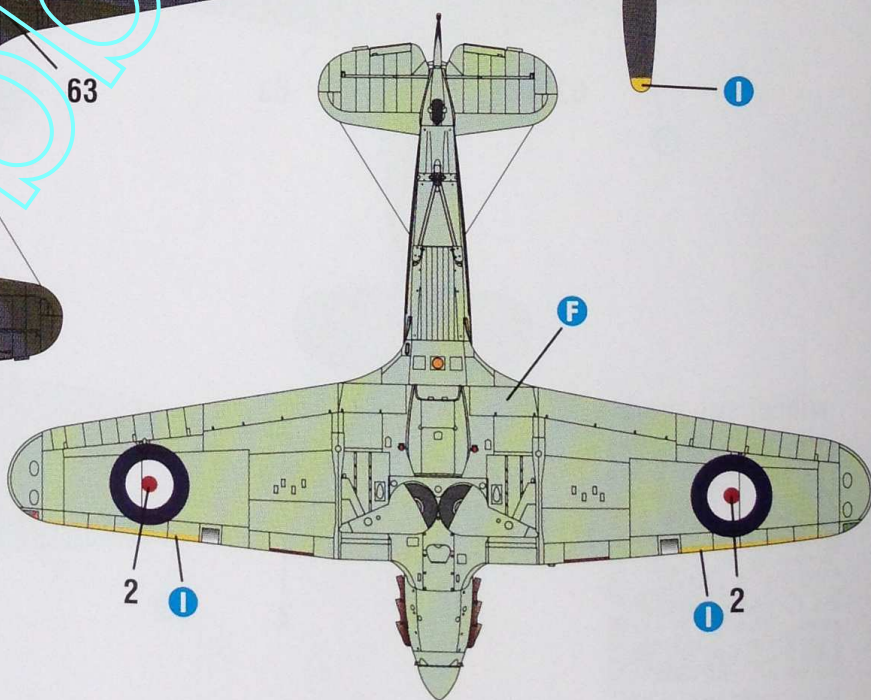
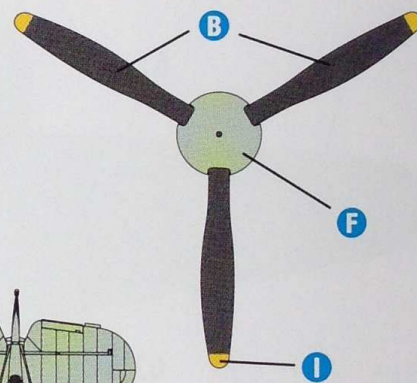
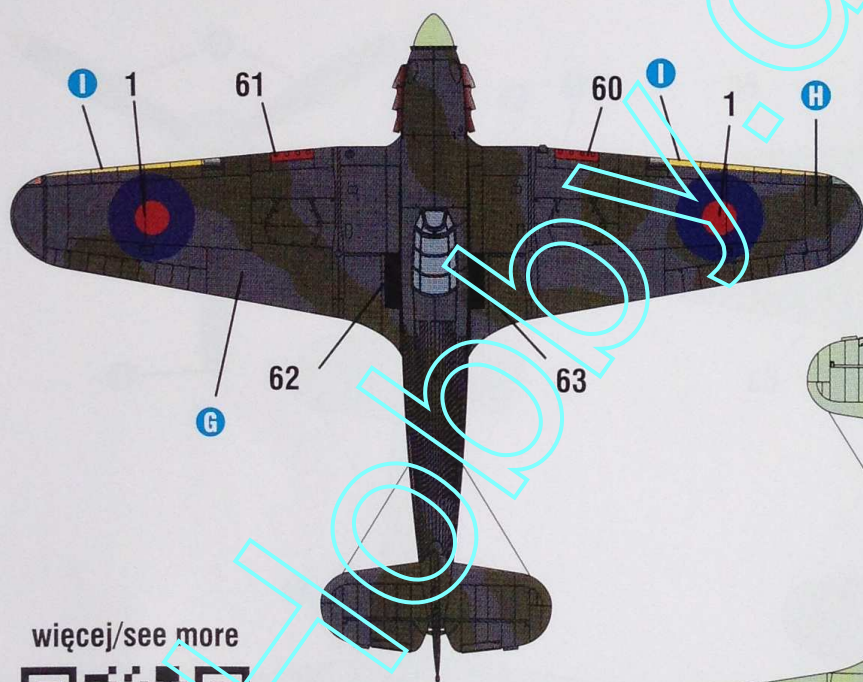
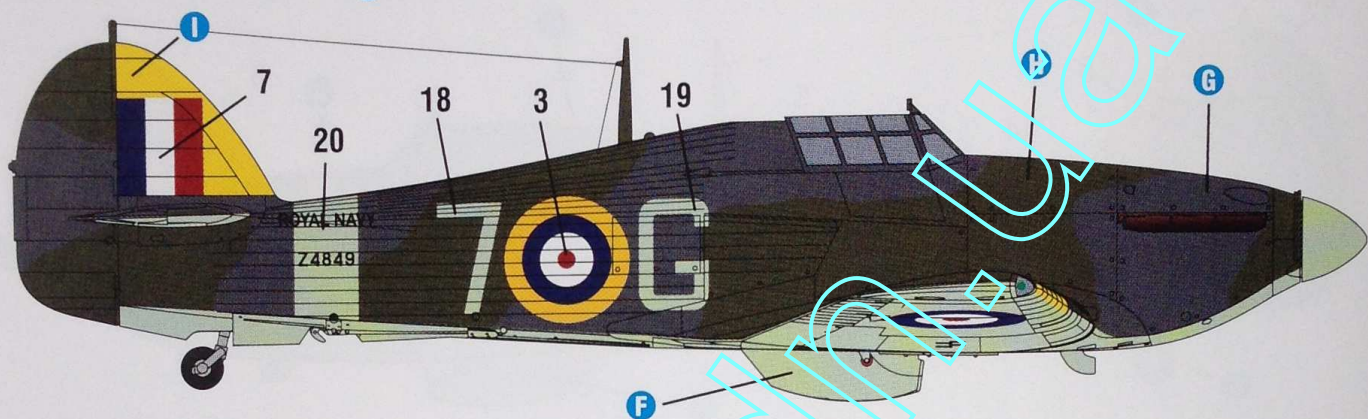
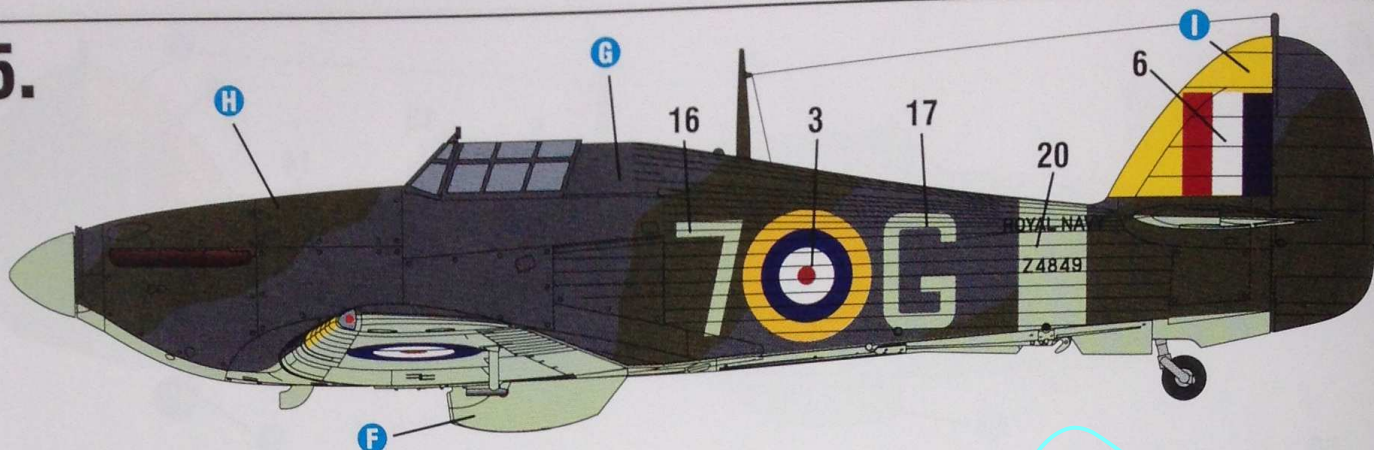

więcej/see more



<http://armahobbynews.pl/70061>

Sea Hurricane IB, Z4849 "7G", pilot: ppor. Hugh Popham, 880. Dywizjon (Naval Air Squadron), lotniskowiec HMS Indomitable. Operacja Pedestal, sierpień 1942 r.

Sea Hurricane IB, Z4849 "7G", pilot: Sub/Lt Hugh Popham, No. 880 Naval Air Squadron, Operation Pedestal, aircraft carrier HMS Indomitable, August 1942