



Fairchild F24

Fairchild Argus MK I,III
Fairchild UC-61

Plastic model

scale :1/72

The Fairchild Model 24, is a four-seat, single-engine monoplane light transport aircraft that was used by the United States Army Air Corps as the UC-61 and by the Royal Air Force. The Model 24 was itself a development of previous Fairchild models and became a successful civil and military utility aircraft.

In an innovative concept, the aircraft was available with two powerplants, Warner's reliable Scarab and Fairchild's in-house 200 hp Ranger series in the F24C-8-D, E and F. Initially the 1932 model Fairchild 24C-8-B used a reliable and popular Warner 125 hp radial engine, and the Fairchild 24C-8-C used the Warner 145 hp radial. American Cirrus and Menasco Pirate inline engines were also occasionally used in some earlier Fairchild 24s. Later models such as the popular 24Ws upgraded to the 165 hp Warner Super Scarab.

The type was also used by the US Army as a light transport and by the Coast Guard, with the designation J2-K. The Civil Air Patrol operated many Fairchild UC-61/24s and some aircraft were fitted with two 100 pound bombs for what became successful missions against German U-boats off the east coast of the United States in the early stages of the Second World War. The UC-61 was also procured by the US Navy as the GK-1 and by the British Royal Air Force as the Fairchild Argus.

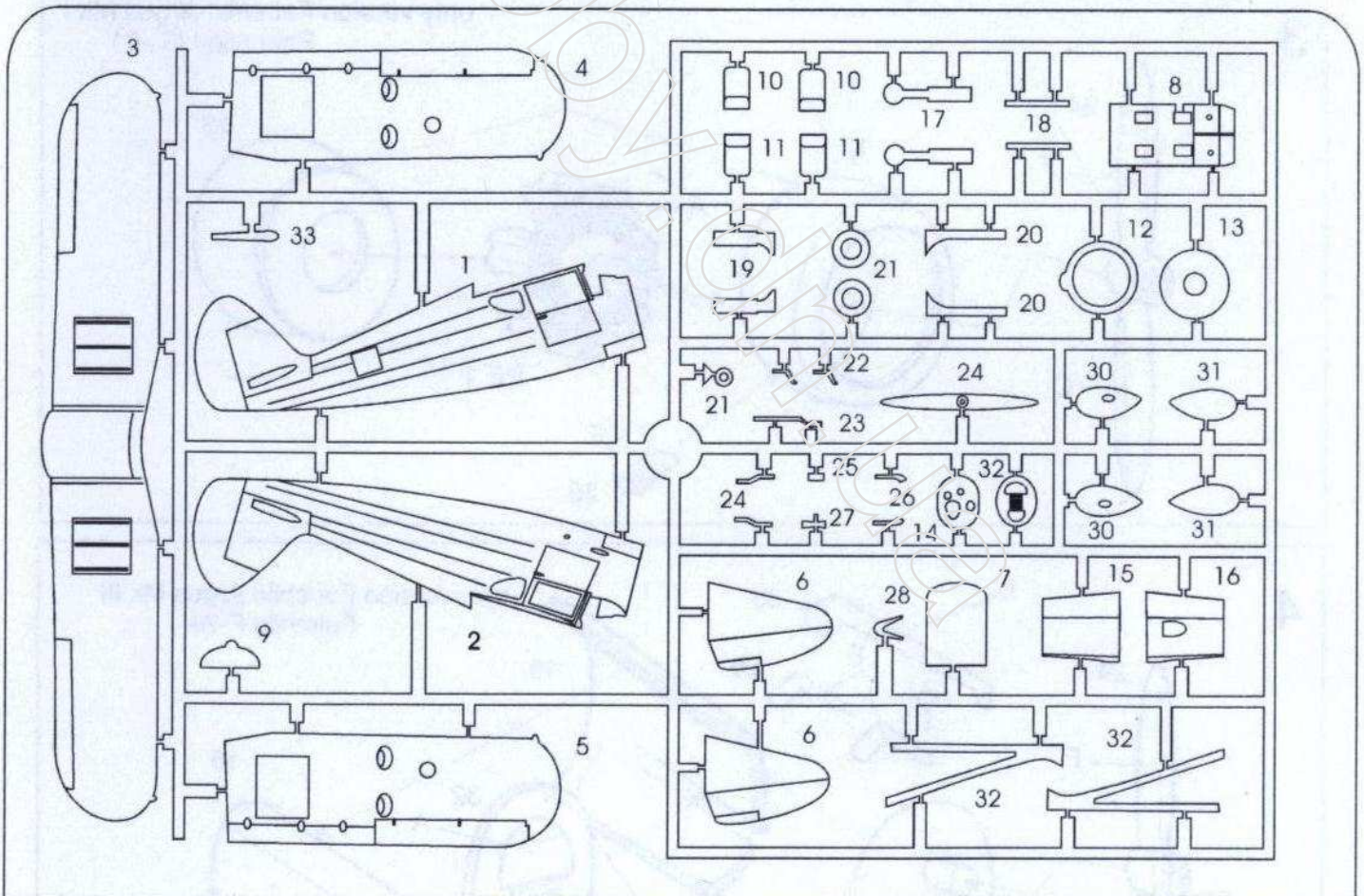

PUR part

only version Fairchild Argus Mk I
Fairchild UC-61

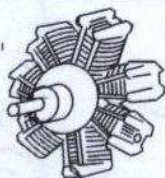

P1

Transparent parts

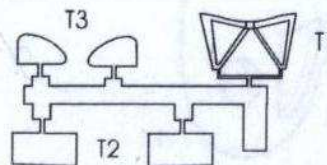

T3

T1

T2

	Colour name	Humbrol		Colour name	Humbrol
A	Black	33	F	Natural Wood	110
B	Interior Green	158	G	Green	120
C	Aluminium	56	H	Tyre Black	85
D	Leather	62			
E	Rust	113			

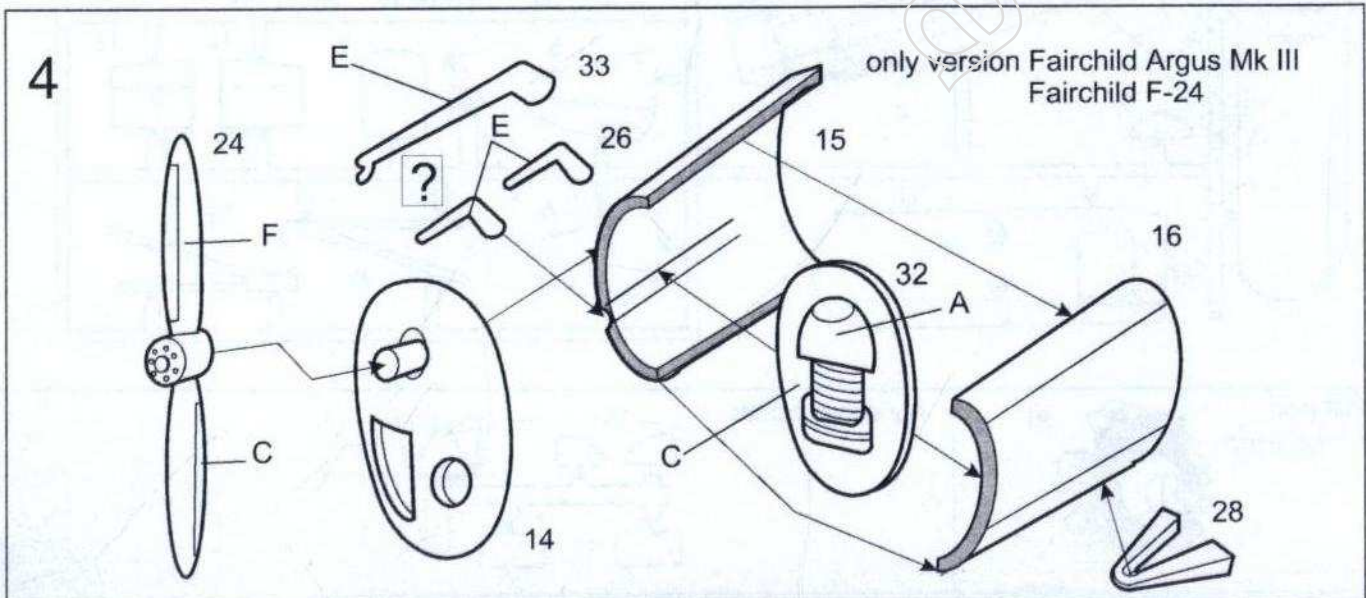
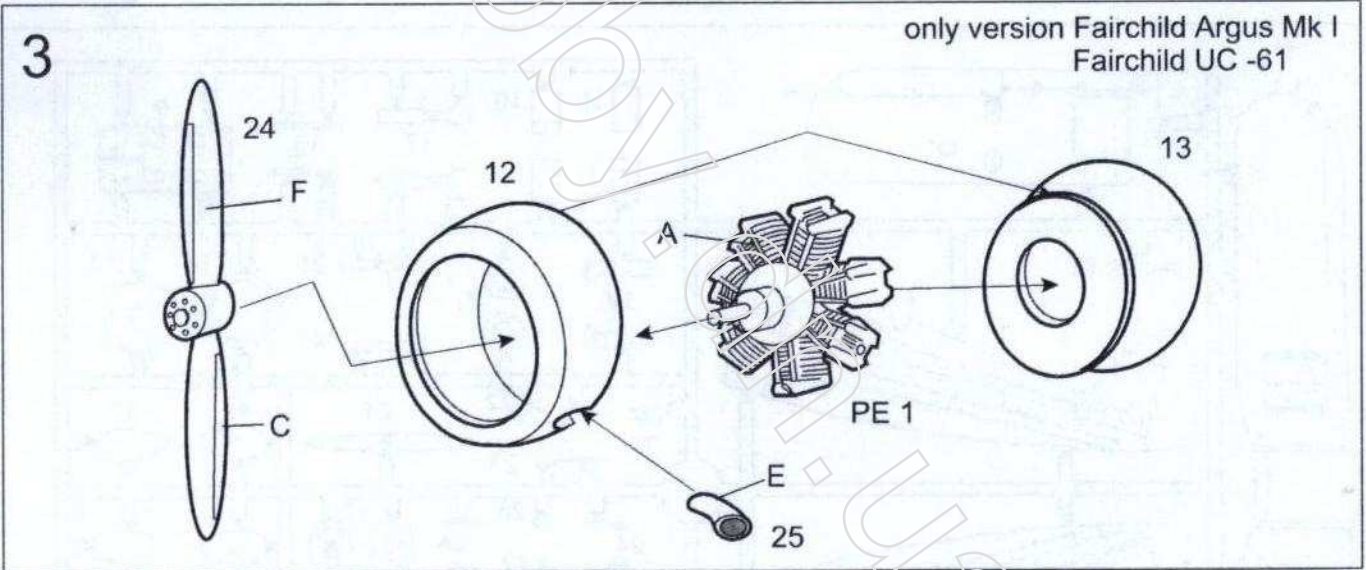
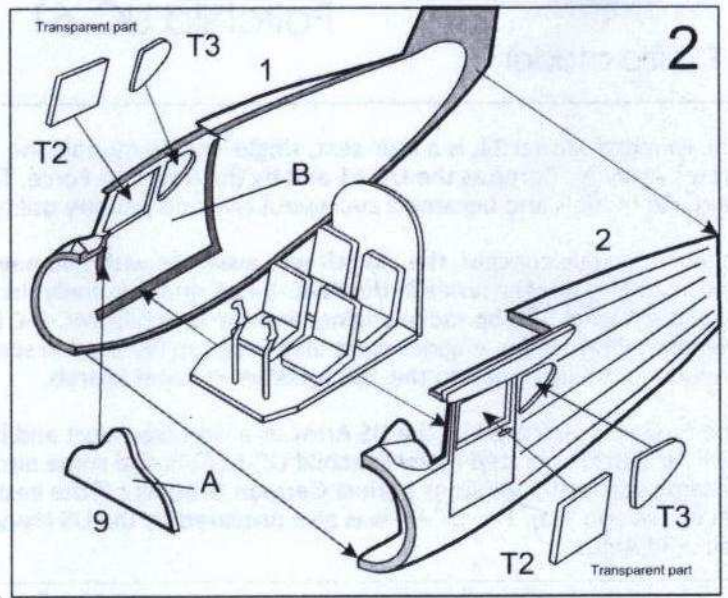
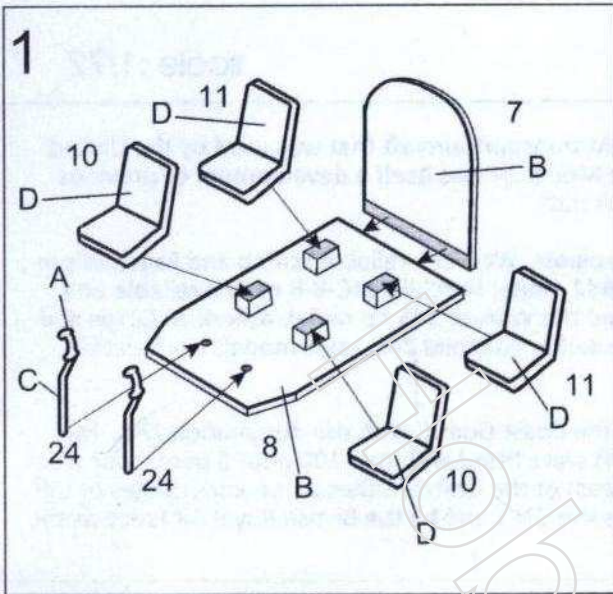

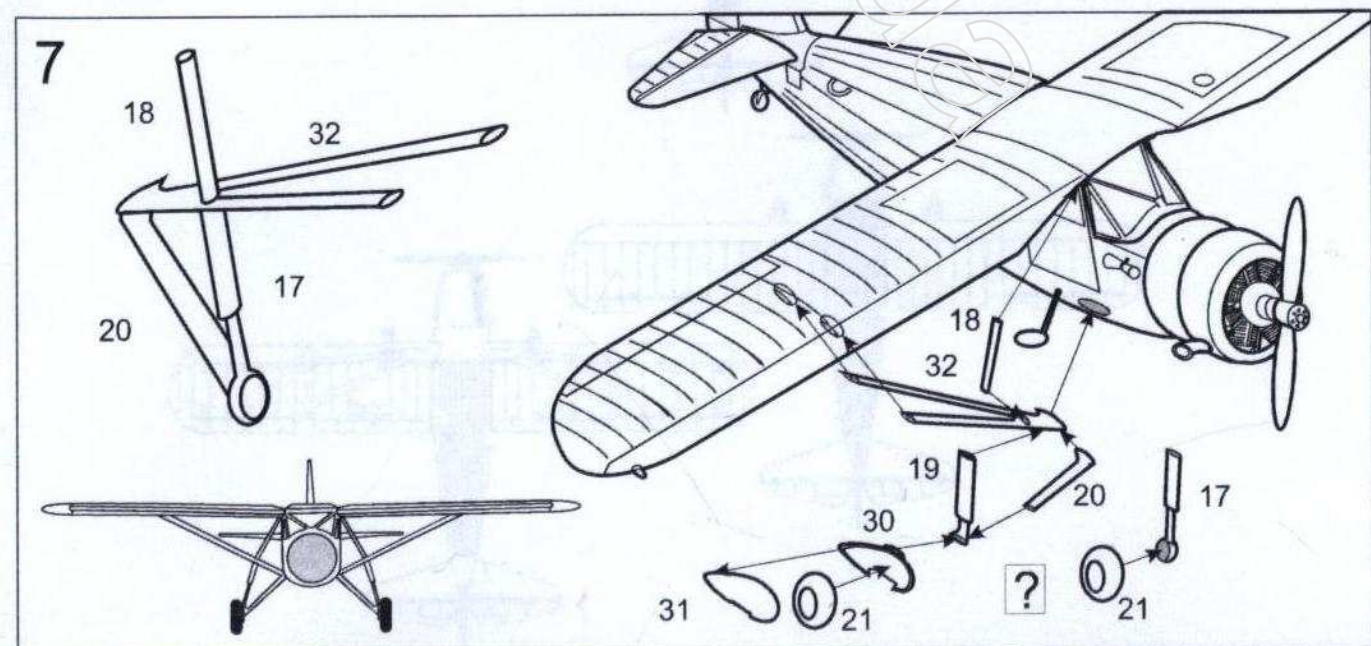
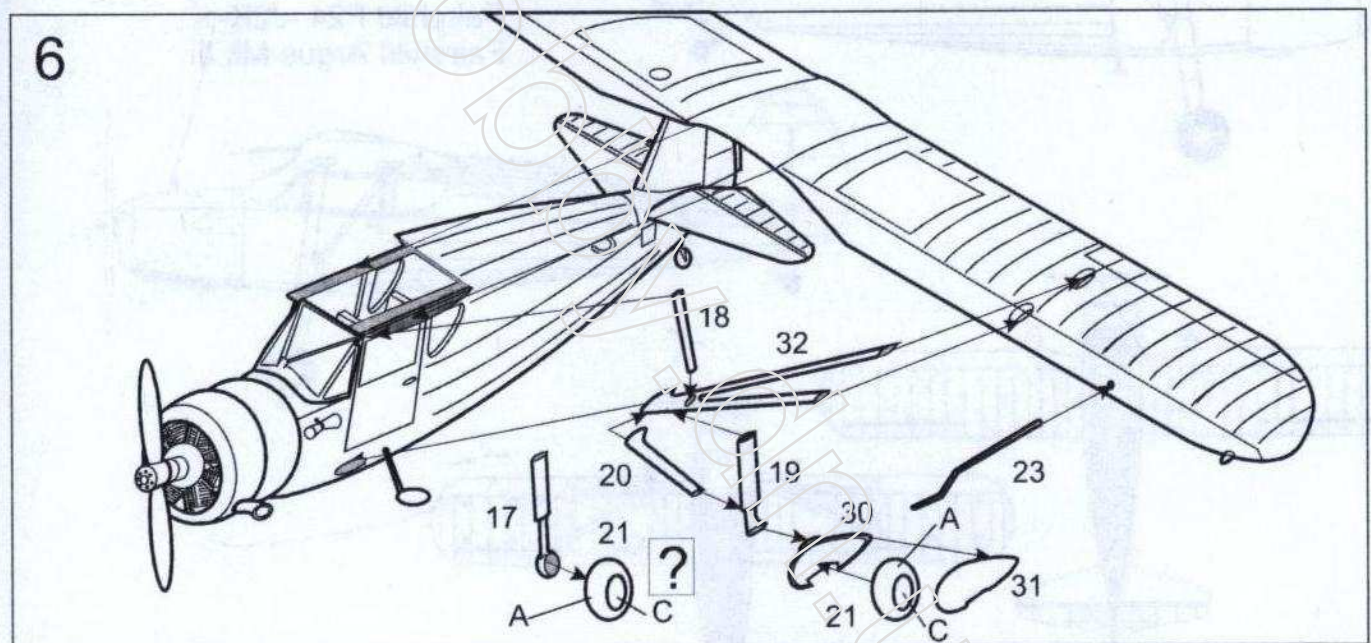
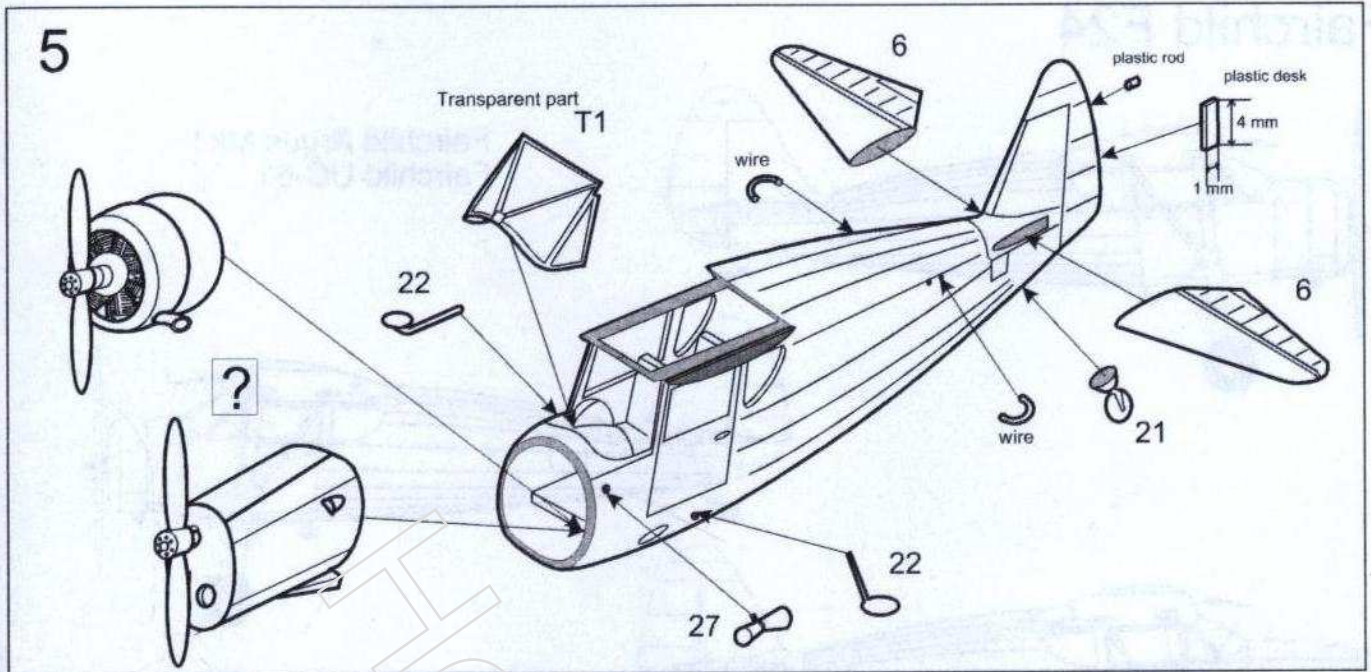

Fairchild F24

Fairchild Argus Mk I
Fairchild UC-61

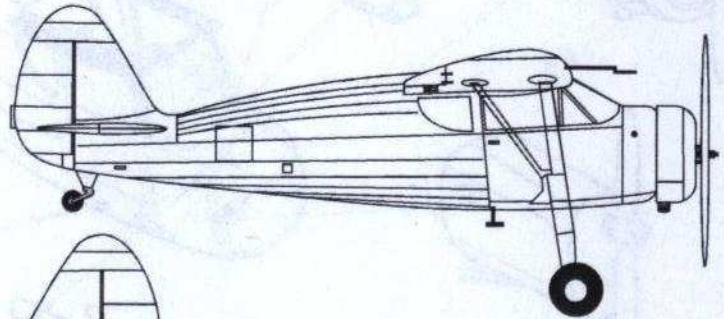
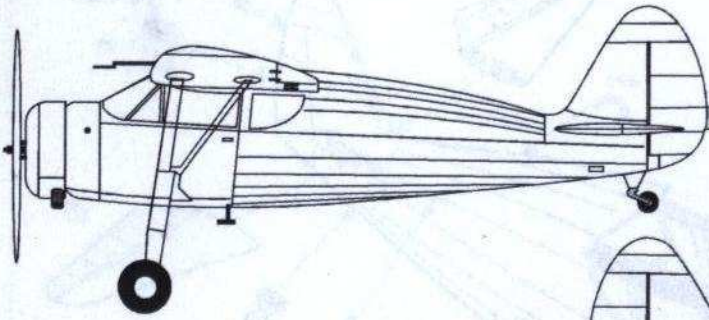

Fairchild F24 -J2K-1
Fairchild Argus Mk III

