

PZL P-11F "In Rumania"

FR0023

1/72

FR Dans les années 30, les chasseurs à aile en mouette Pulawski connaissent un long développement en Pologne (P.1, P.7, P.11, P.24) où le P.11c est le chasseur standard polonais en septembre 1939 et fait face à la Luftwaffe, avec quelques P.7. Cette ligne de chasseurs connaît également de beaux succès à l'exportation. La Roumanie acquiert 50 PZL P.11. b qui sont livrés en 1932, identiques aux P.11a mais avec montage d'un moteur Gnome-Rhône 9Krsd (n° de 1 à 50). IAR obtient ensuite une licence de production pour 95 P.11f, qui est la version locale du P.11c, et s'en distingue par le montage d'un moteur Gnome-Rhône 9Krs6 (610 Cv). La production commence en 1936 à l'usine IAR de Brasov (n° de 51 à 145). A la chute de la Pologne, l'ARR se voit également renforcée par l'arrivée d'avions polonais, parmi lesquels un certain nombre de P.11c. Le 22 juin 1941, les escadrilles n°43, 44 et 45 sont affectées au Groupe 3 de Chasse, alors que les escadrilles n°46, 49 et 50 dépendent du Groupe 4 de Chasse. Toutes ces escadrilles sont alors équipées en PZL P.11f (mais quelques P.11c remplacent ultérieurement les appareils endommagés ou détruits). Les appareils roumains ne démeritent pas face à la chasse soviétique de l'époque. Entre le 28 juin et le 22 septembre 1941, les deux Groupes de Chasse n°3 et n°4, équipés de P.11, revendiquent de 40 à 46 Rata (Polikarpov I-16), ce qui vaut aux pilotes roumains le surnom de "tueurs de Rata". C'est probablement pour cette raison que certains font peindre leurs victoires sous une forme plutôt inhabituelle : un pilote dans un PZL tenant en laisse un ou deux Rata. En contrepartie, 18 PZL P.11f sont perdus lors de la campagne de Bessarabie. Quelques futurs As font partie de l'escadrille n°43. Dan Vizanti, qui commande l'escadrille, obtient une victoire le 17 septembre, Mircea Dumitrescu est abattu le 31 août à bord du n° 64 mais peut sauter en parachute. Après la première campagne, les PZL P.11 sont retirés du front et utilisés dans les écoles de pilotage. Ainsi, de nombreux pilotes roumains ont l'occasion d'utiliser ce petit chasseur, soit lors de la campagne de Bessarabie, soit, pour les plus jeunes, lors de leur passage en école. Une version avec skis est expérimentée pendant l'hiver 41-42, elle peut être montée avec cette boîte (voir 122 blanc, ci après) qui contient les skis expérimentaux et l'appareil accroché sous le fuselage du 122 (caméra? appareil de mesure? Toutes les informations sont bien venues).
 Spécifications: chasseur monomoteur monoplace à aile en mouette et train fixe, tout métal. Envergure 10,70 m longueur 7,60 m, poids maximum 1590 kg, vitesse max 340 km/h à 5.000 m, plafond opérationnel 11.000 m, rayon d'action 700 km. Moteur: un IAR 9Krs6 de 610 Cv. Armement: 4 mitrailleuses Vickers de 7,7 mm.

GB Pulawski's gull wing fighters were developed in Poland through a series of PZL designs (P.1, P.7, P.11 and P.24). The P.11c was the standard Polish Air Force fighter in September 1939, and along with some PZL P.7's had to oppose a more modern Luftwaffe. PZL also sold the P.11 to several foreign customers. One was Rumania, which bought fifty of the P.11. b version. These were delivered during 1932 and coded from 1 to 50. They were similar to the P.11a, but powered by the Gnome-Rhône 9Krsd. The Rumanian manufacturer, IAR, then produced ninety-five P.11fs under licence. These were a Rumanian version of the P.11c, powered by Gnome-Rhône 9Krs6 (610 HP), and had a modified cowling. Production started in 1936 at IAR's Brasov plant; airframe codes 51 to 145 being allocated to these. At Poland's fall large quantities of Polish aircraft, including some P.11cs, escaped to Rumania. On June 22nd 1941, N°43, 44 and 45 Squadrons were part of Fighter Group N°3, whilst N°46, 49 and 50 Squadrons formed Fighter Group N°4. These squadrons were equipped with P.11fs built by IAR, although some ex-Polish P.11cs did later replace damaged aircraft. Rumania's planes proved equal or better than their Soviet opponents. Between June 28th and September 22nd 1941, N° 3 and 4 Fighter Groups, using mainly P.11fs, claimed between 40 and 46 Ratas (Polikarpov I-16). This earned them the nickname of "Ratas killers". Some pilots displayed their tallies on a rather unusual way by showing a PZL pilot holding one or two Ratas on a leash. These successes were obtained for the loss of eighteen P.11fs during the Bessarabian campaign. Some Aces belonged to N°43 Squadron. The Squadron leader, Dan Vizanti, scored a victory on September 17th, while Mircea Dumitrescu was shot down on August 31st, crashing the airframe N° 64, but bailing out safely. P.11's were progressively removed from front line operations to serve in training schools. Consequently, many Rumanian pilots got the opportunity to fly this little fighter, either during the Bessarabian campaign or as new pilots during training. Tests were done using two P.11fs on skis during winter 1941-1942, one of these planes was N° 122. As well the experimental skis, the kit includes an as yet unidentified device secured to the bottom of fuselage (was it a camera or a calibration device? We welcome any information on this).
 Specifications: All-metal, single-engine, single seat, gull wing fighter with fixed landing gear. Wingspan 10,72 m, length 7,60 m, maximum weight 1590 kg, max speed 340 km/h at 5.000 m, operational ceiling 11.000 m, range 700 km. Weapons: 4 x 7.7 mm Vickers machine guns. Engine: one IAR 9Krs6 developing 610 HP (licence-built Gnome & Rhône).

A

B

C

D

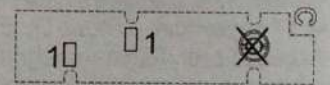
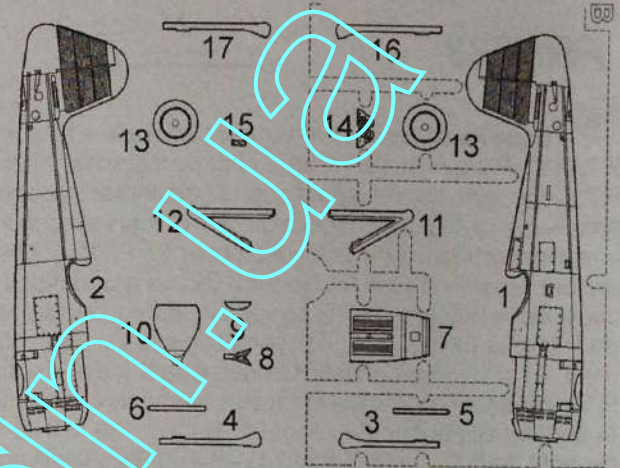
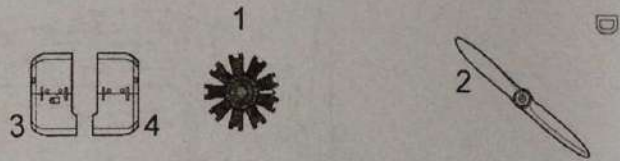
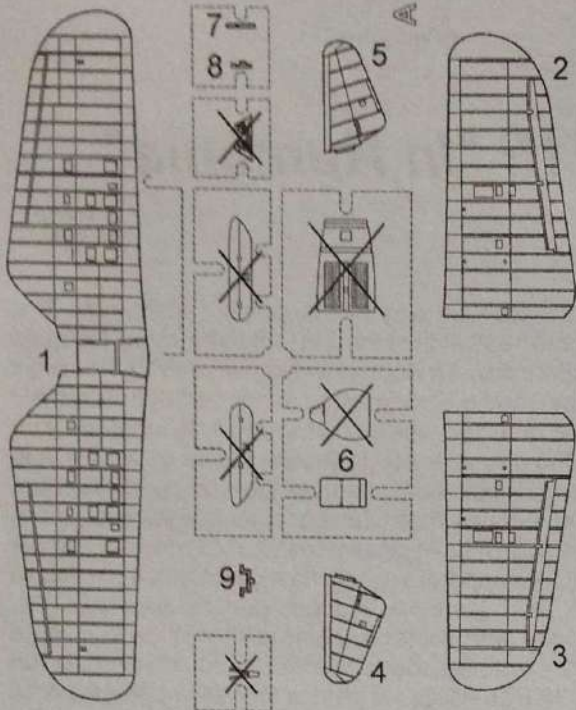

PUR POLYURETHAN PARTS (PUR)

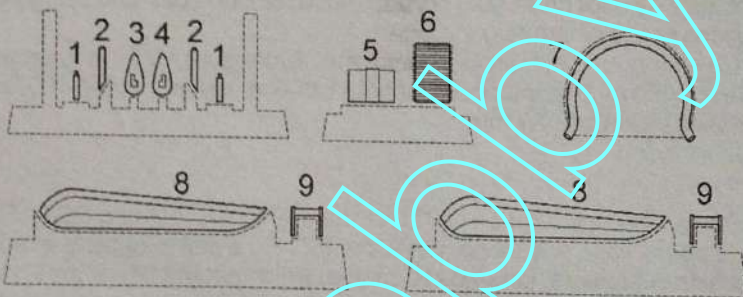

Couleurs GUNZE / GUNZE Colour No.

PP PHOTO-ETCHED PARTS (PP)

CP CLEAR PARTS (CP)

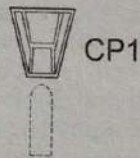
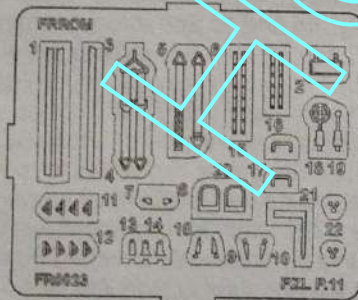

A	Rouge / Red	H3
B	Blanc / White	H11/C62
C	Noir / Black	H12/C33
D	Cuir / Leather	H17/C29
E	Bois / Wood	H37/C43
F	Gris / Grey	H53/C13
G	Noir Pneu / Tyre Black	H77/C137
H	Len / Linen	H85/C45
I	Gris / Grey	H306/C306
J	Rouille / Rust	H344
K	Acier noirci / Dark Iron	MC214
L	Aluminium / Aluminium	MC218
M	Cuivre / Copper	MC215

Dii PP16 nepoužit / Part PP16 not used

Volba
Optional
Nach beliebigen
Option

Odstranit
Remove
Entfernen
Detacher

Lepidlo na kov
Glue for metal
Metallkleber
Colle a metal

Obtisk
Decal
Abziehbilder
Decalque

Barva
Color
Farben
Peindre

Clear fix

1

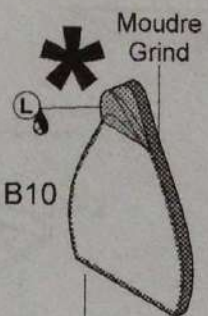
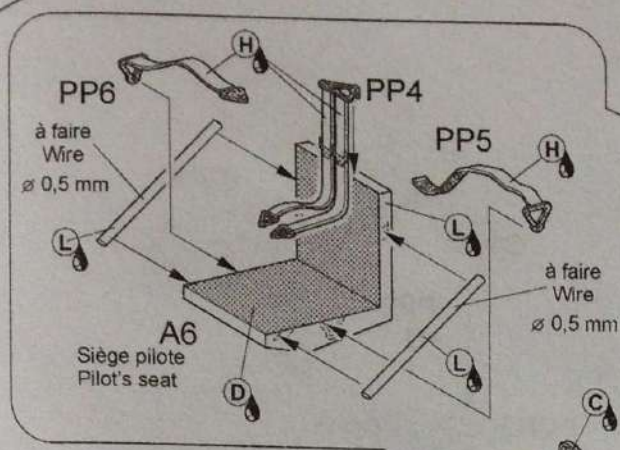

2

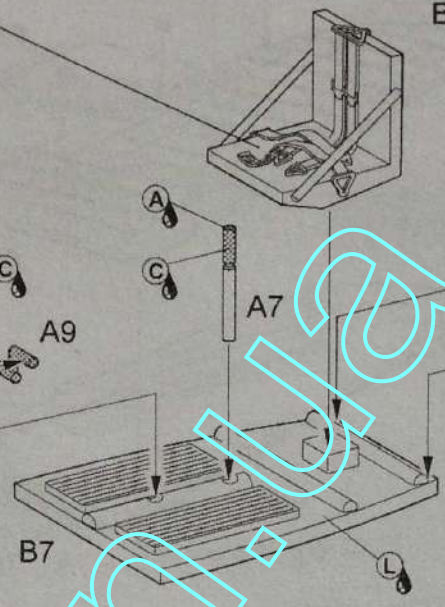
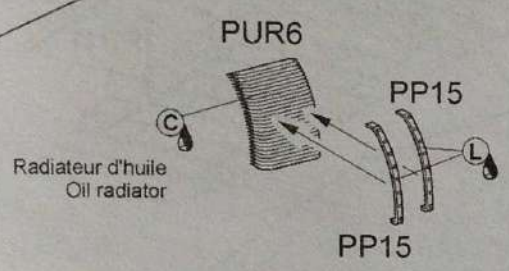

3

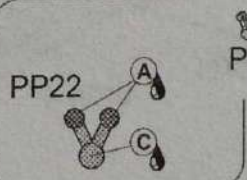
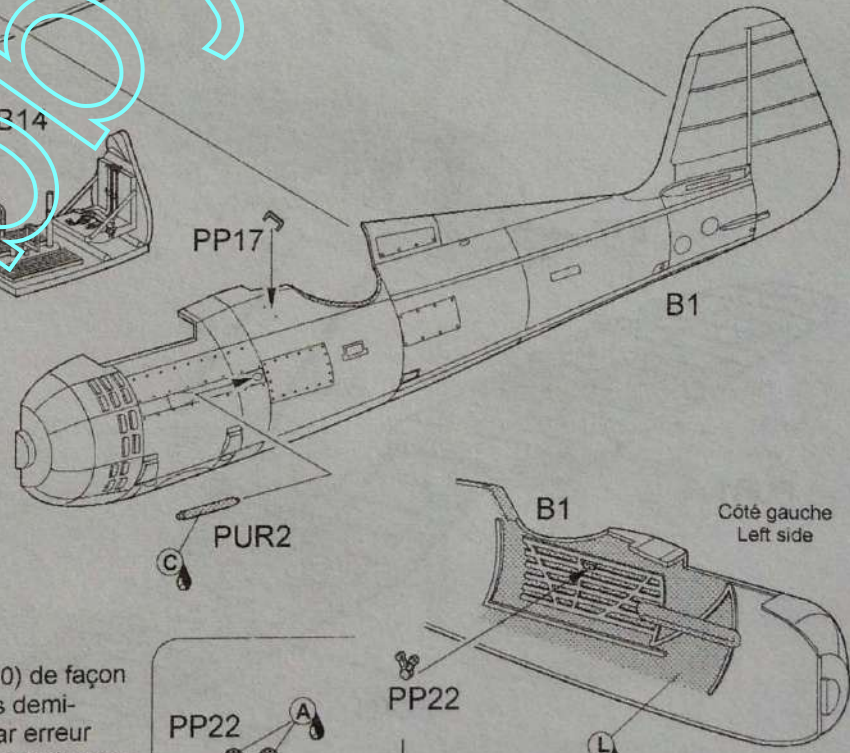
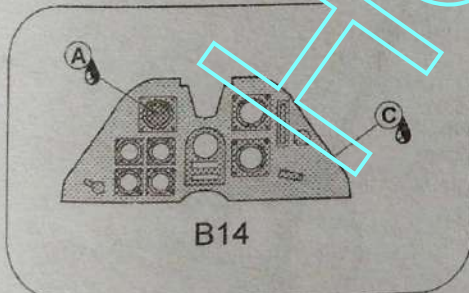
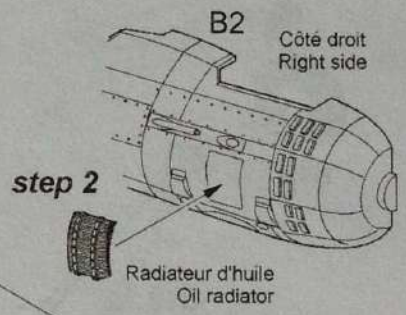
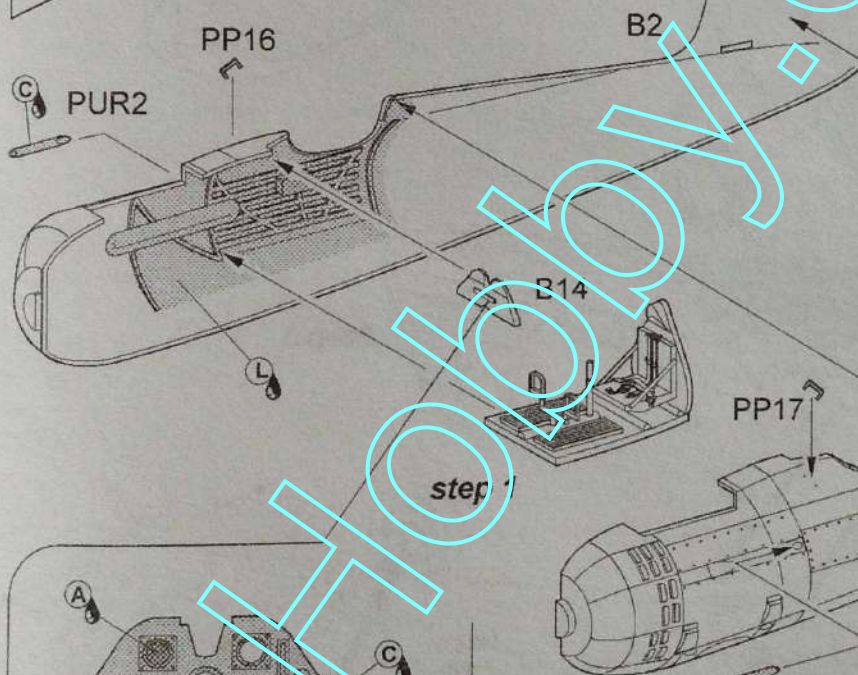

* Veuillez travailler le repose-tête (pièce B10) de façon à assurer un assemblage harmonieux des demi-fuselages. Cette pièce a été remplacée par erreur durant la préparation du moule. Veuillez accepter nos excuses pour ce désagrément Grind the shape of the fuselage bulkhead (part B10) to fit smoothly prior mating the fuselage halves. Unfortunately this part was substituted during the mould preparation. Please accept our apologies.

4

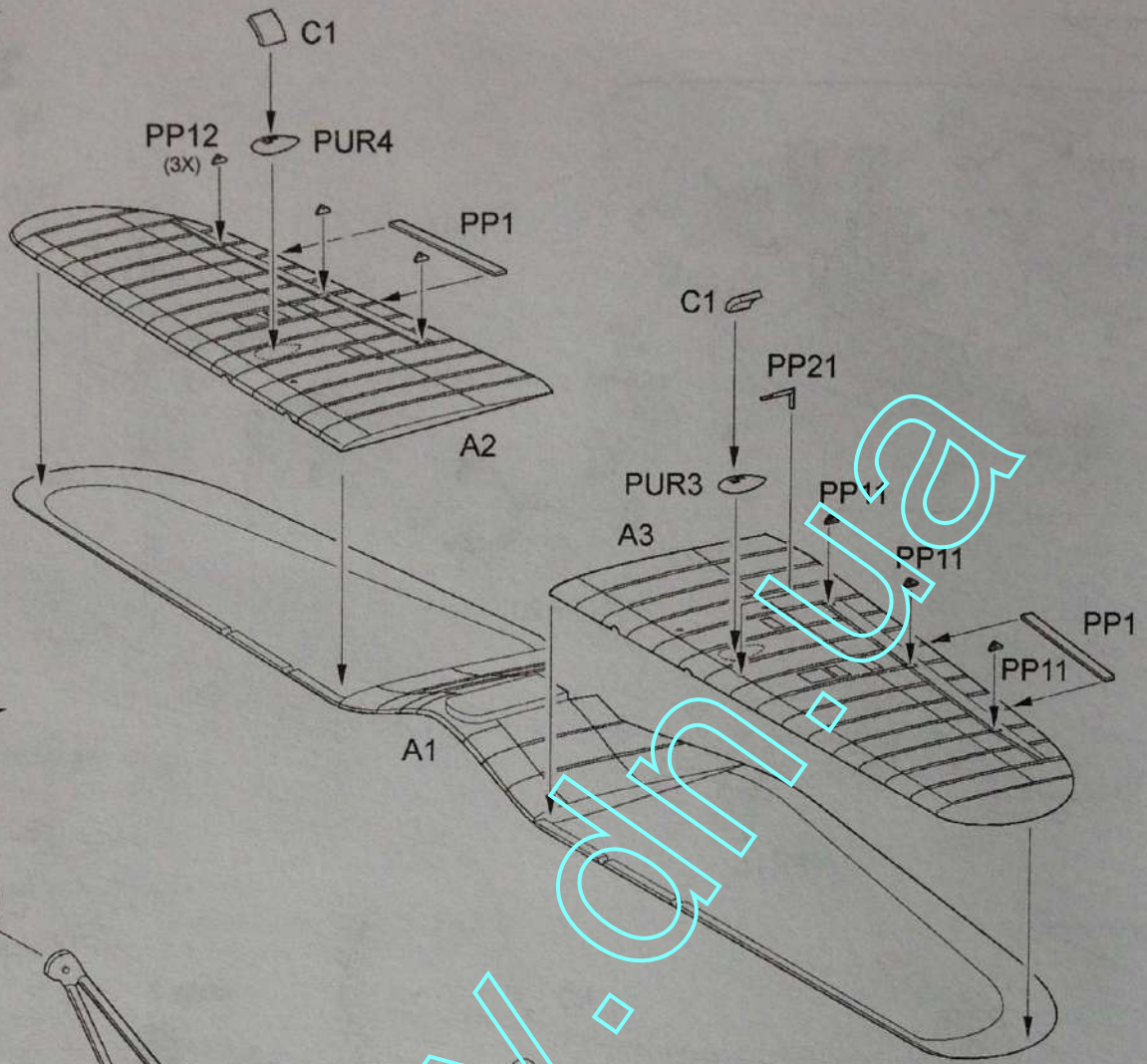

5

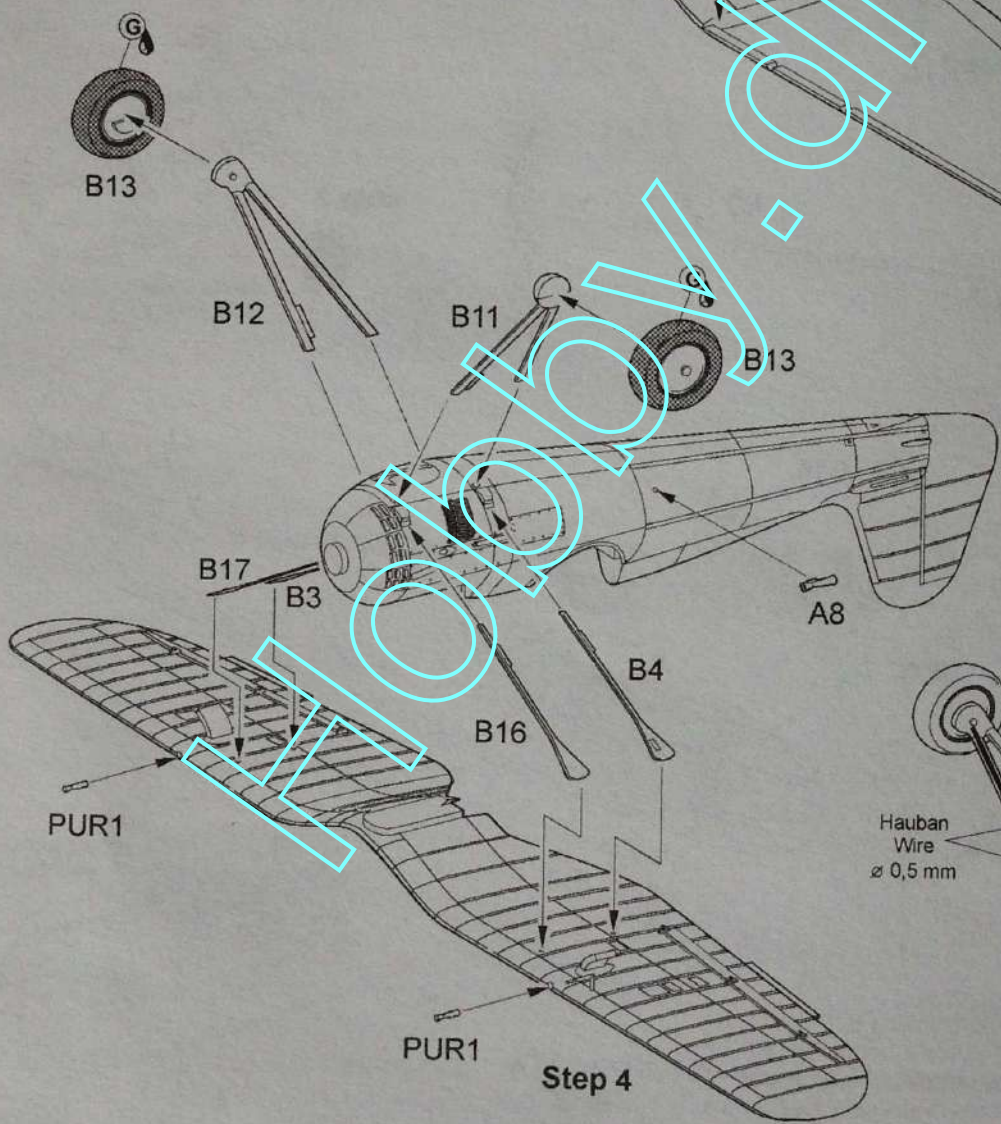

Step 3

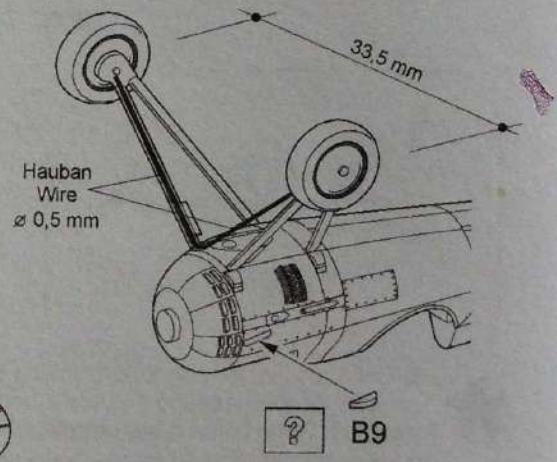

Step 4



Appareil remorqueur de cibles
Aircraft for target towing

Rétroviseur
Rearview mirror

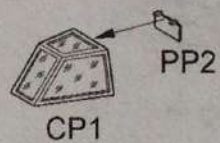

Atelage de remorquage de cibles
Hitch for towed target

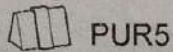

Cet appareil n'était pas armé
Toy machine was not armed

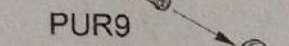
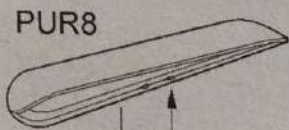

Drât Wire
ø 0,5 mm

B12



PUR8



Step 3

B17 B3

A8

B10

B4

PUR1

PUR1

Step 4

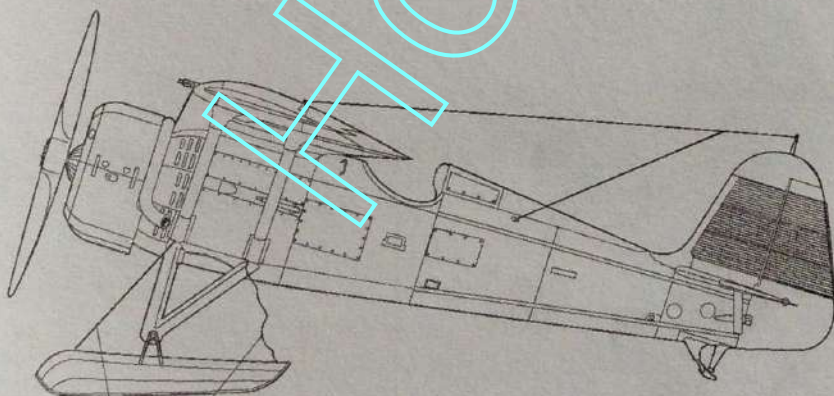

Hauban Wire
ø 0,1 mm

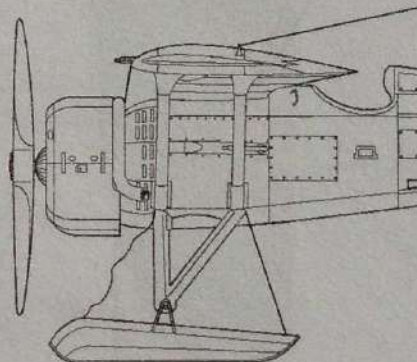

7

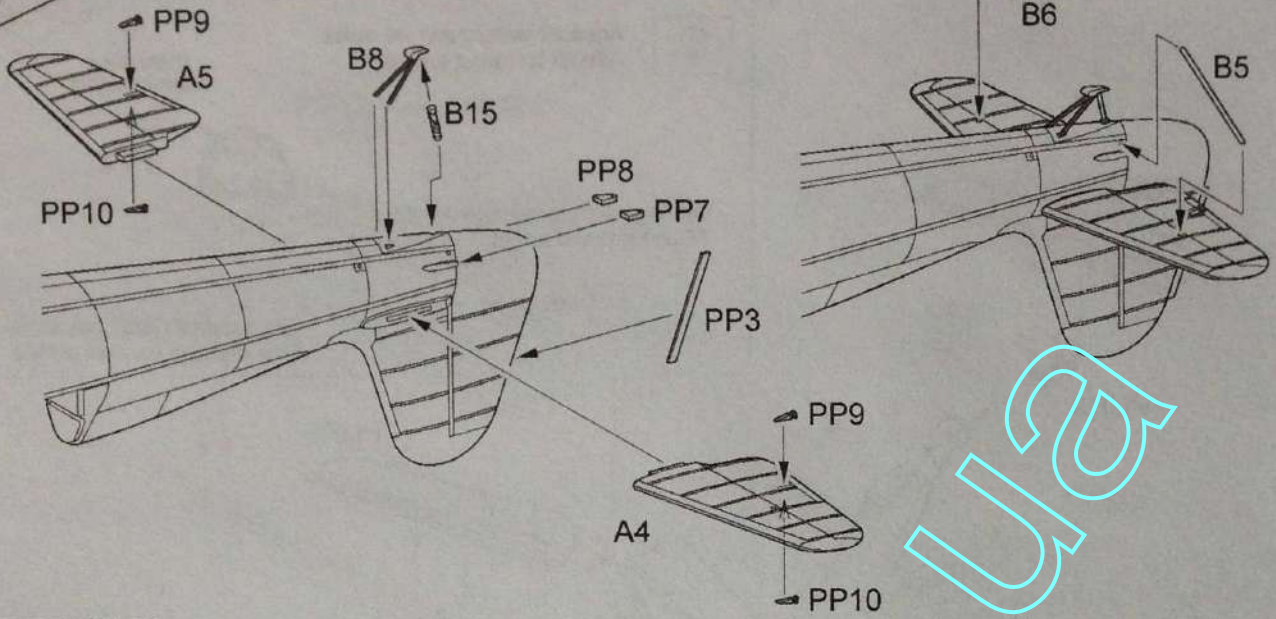

8

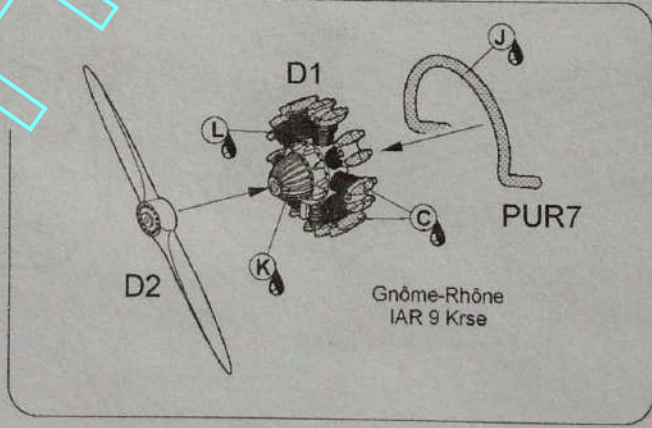
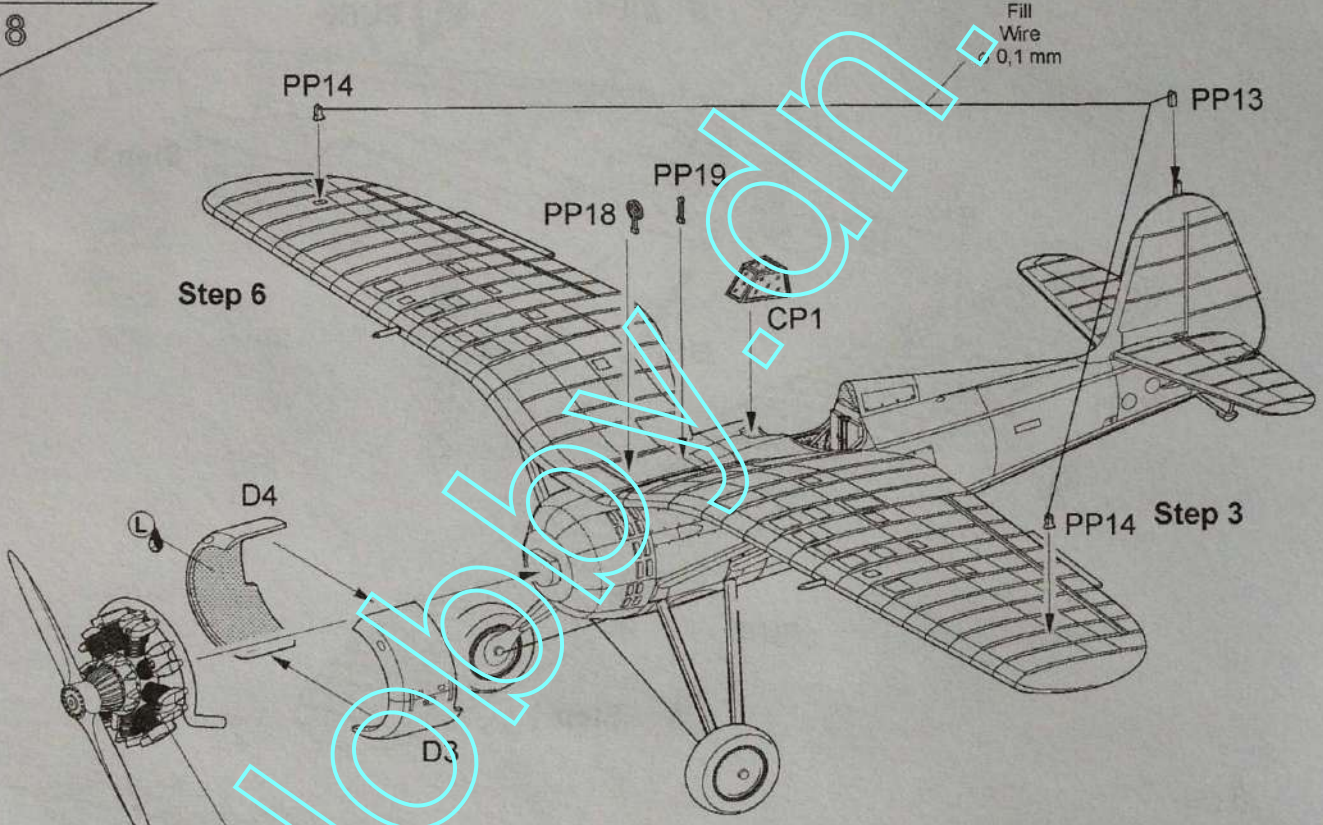

PZL P.11f No. 79, Pilote Adjudant Stag. Av. Ioan Dimache, escadrille 43, Grupul 3
Vânătoare, Baden aéroport, août 1941.

PZL P.11f No. 79, Pilot Adjudant Stag. Av. Ioan Dimache, squadron 43, Grupul 3
Vânătoare, Baden airfield, August 1941.

CAM. A

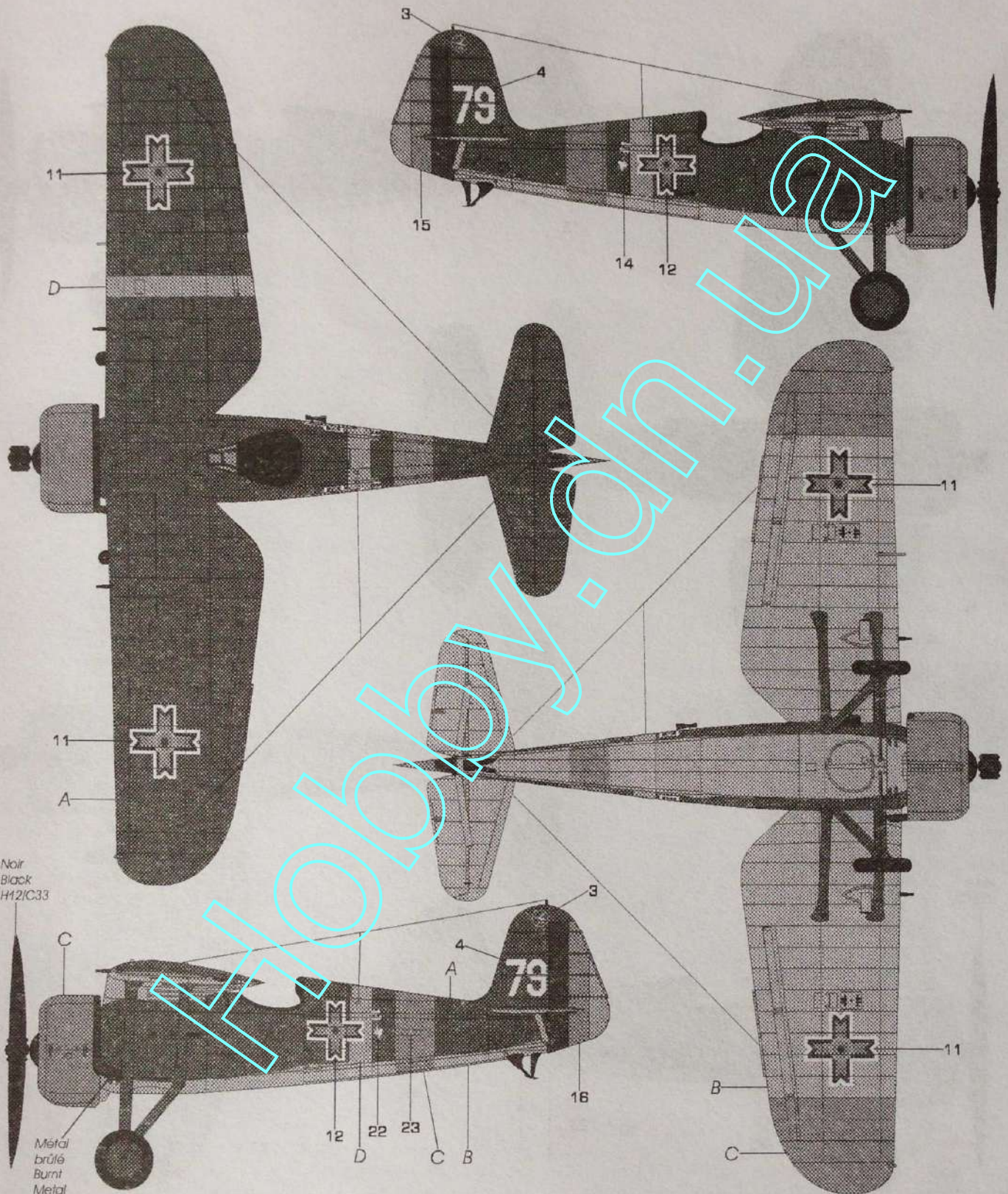

Noir
Black
H12/C33

Métal
brûlé
Burnt
Metal

A Brun vert olive
Olive Green
H309 / C309

B Bleu Clair
Light Blue
H67 / C115

D Rouge
Red
H3 / C3
C Jaune
Yellow
H4 / C4

Les schémas de camouflage en couleur sont téléchargeables sur notre site
The camouflage schemes in colour are downloadable through our website
www.froom.com

Production
GUNZE
SANGYO

2013/09

FR0023 PZL P.11f

PZL P.111 No. 87, Pilote Adjudant Stag. Av. Marian Voica, escadrille 50, Grupul 4
 Vânătoare, Bacălu aéroport, août 1941.

PZL P.111 No. 87, Pilot Adjudant Stag. Av. Marian Voica, squadron 50, Grupul 4
 Vânătoare, Bacălu airfield, August 1941.

CAM. B

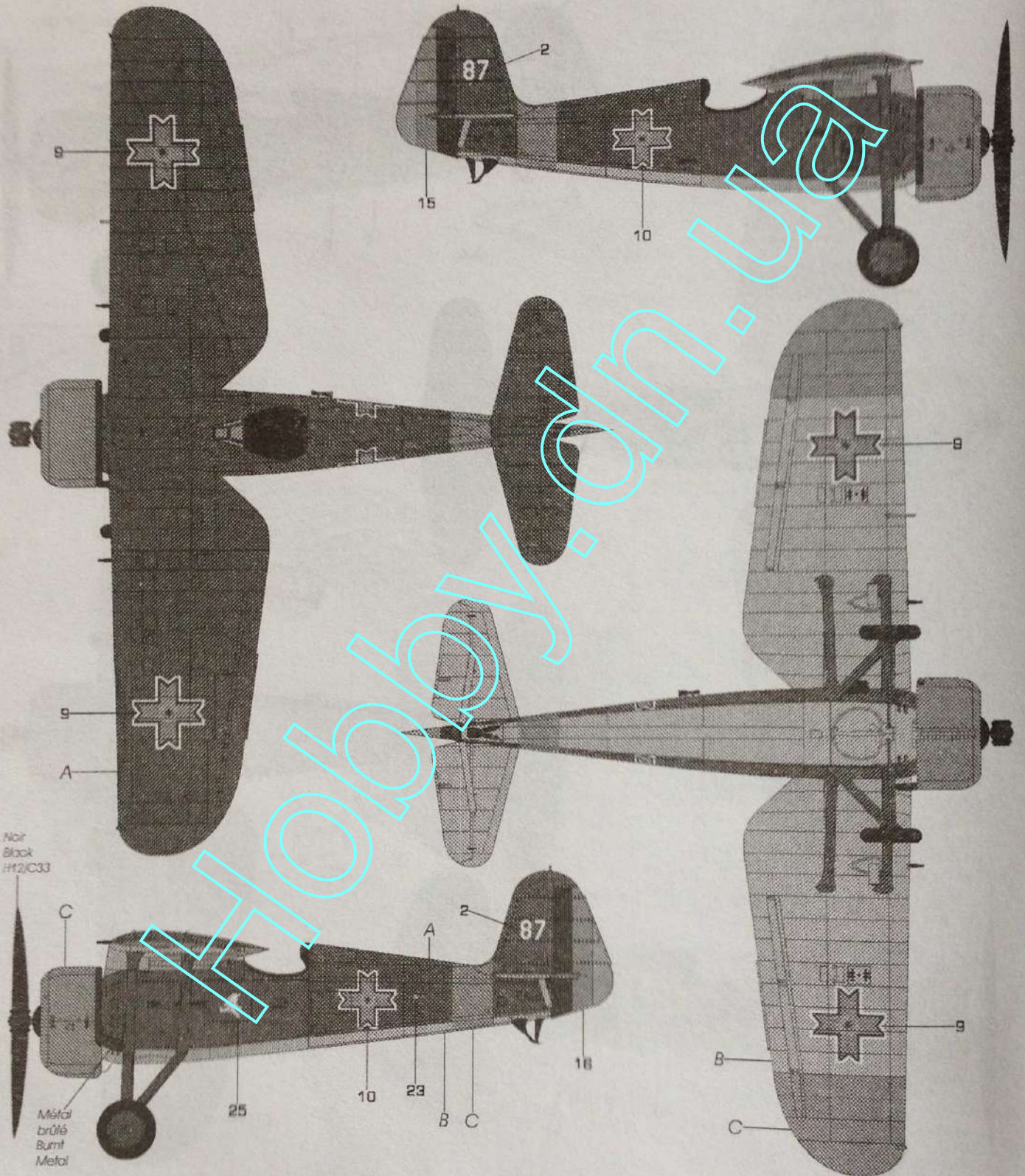

Noir
 Black
 H12/C33

Métal
 brulé
 Burnt
 Metal

- A** Brun vert olive
 Olive Green
 H309 / C309
- B** Bleu Clair
 Light Blue
 H67 / C115
- C** Jaune
 Yellow
 H4 / C4

Les schémas de camouflage
 en couleur sont téléchargeables
 sur notre site

The camouflage schemes
 in Colour are downloadable
 through our website

www.from.com



PZL P.111 No. 51, Pilote Serg. TR Av. Romeo Neacșu, escadrille 43, Grupul 3 Vânătoare, Baden aeroport, octobre 1941.

PZL P.111 No. 51, Pilot Serg. TR Av. Romeo Neacșu, squadron 43, Grupul 3 Vânătoare, Baden airfield, October 1941.

CAM. C

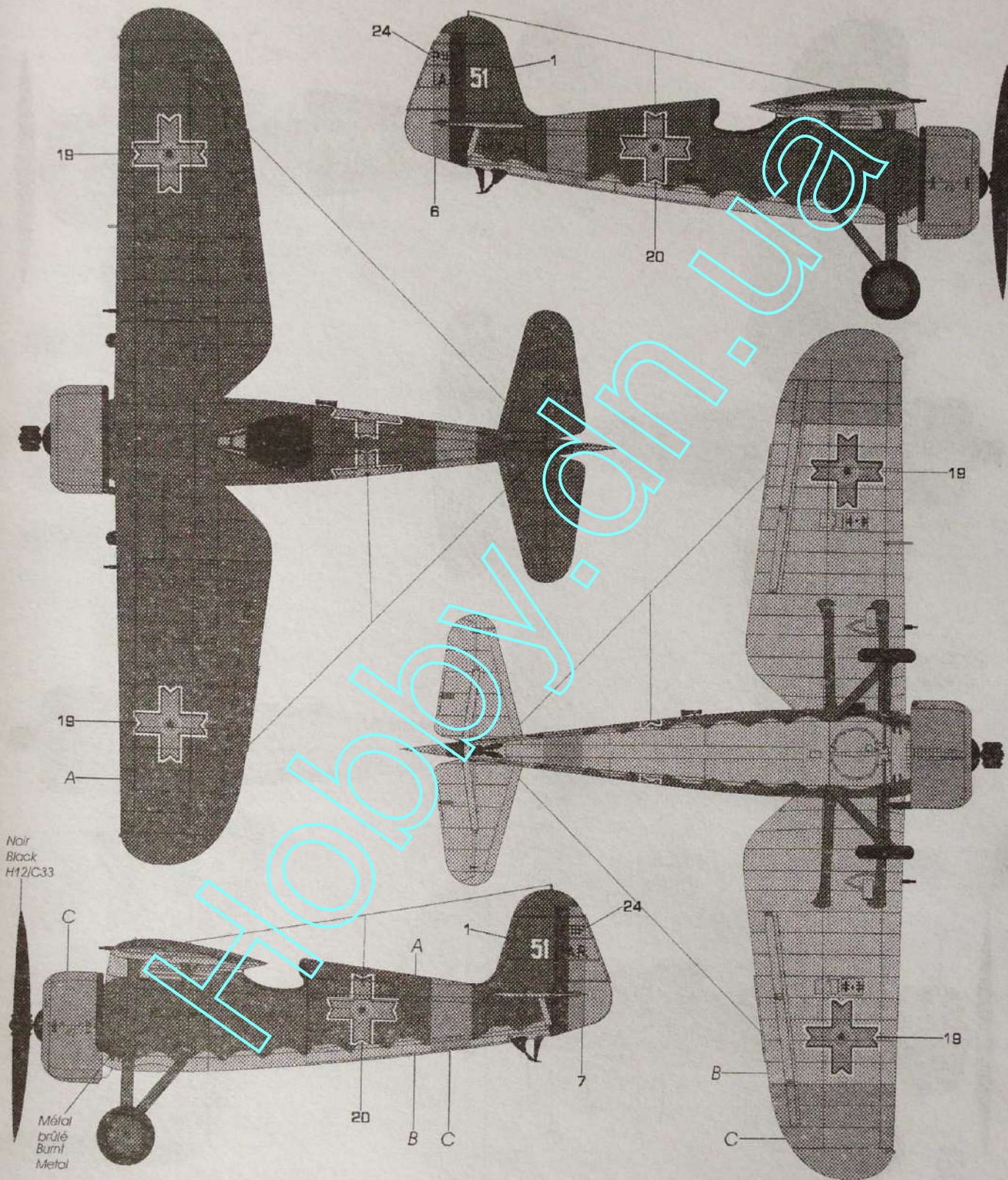

Noir
Black
H12/C33

Métal
brûlé
Burnt
Metal

A Brun vert olive
Olive Green
H309 / C309

B Bleu Clair
Light Blue
H67 / C115

C Jaune
Yellow
H4 / C4

Les schémas de camouflage en couleur sont téléchargeables sur notre site
The camouflage schemes in Colour are downloadable through our website
www.frrom.com

Production
GUNZE SANGYO

2013/09

FRO023 PZL P.111

CAM. D

'contraste dû à l'usage sur certaines zones de peinture récente - gouvernail repeint'
 'contrast coming from use of newer paint on some parts - rudder repainted'

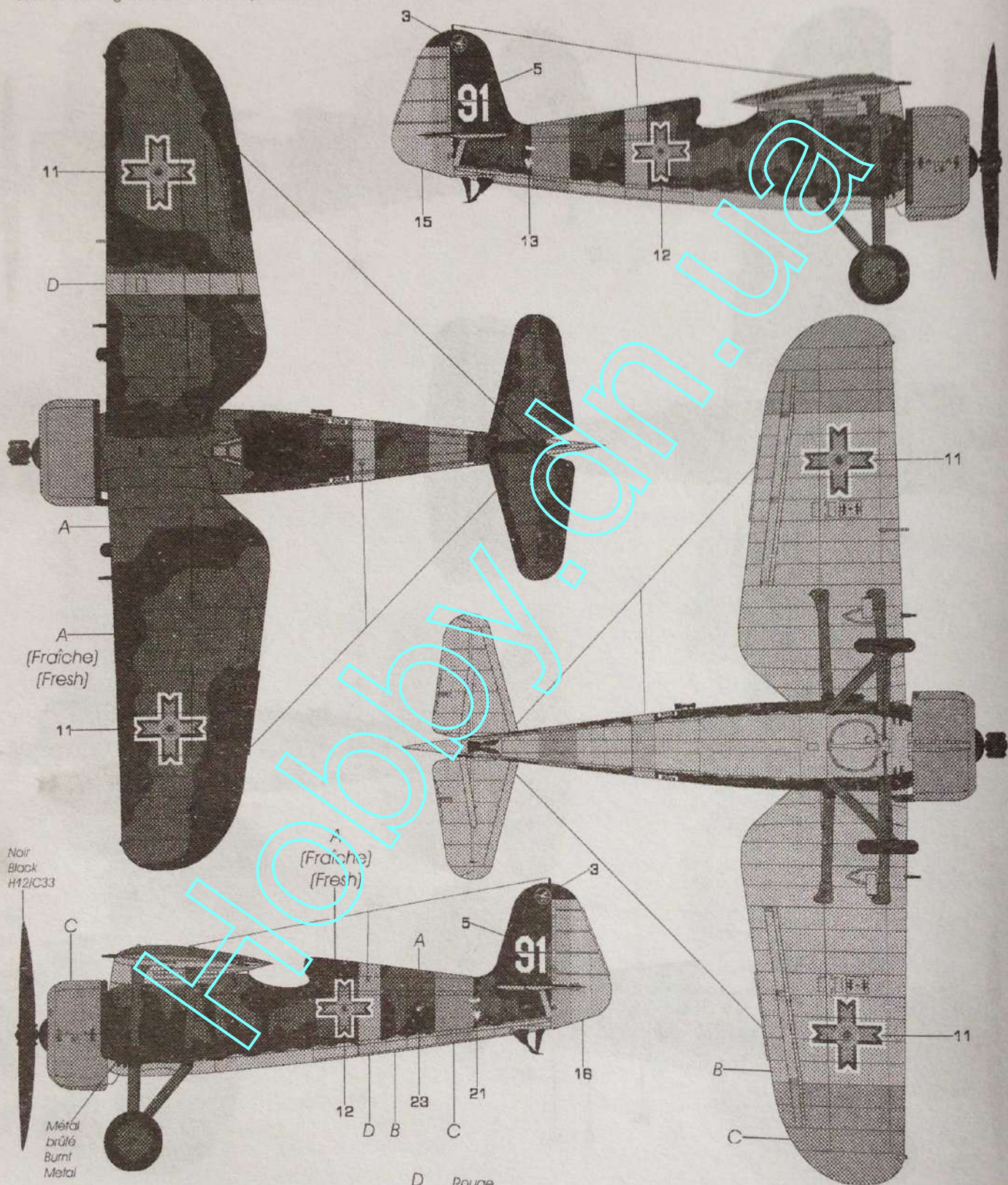

Noir
Black
H12/C33

A
(Fraîche)
(Fresh)

A
(Fraîche)
(Fresh)

A Brun vert olive
Olive Green
H309 / C309

B Bleu Clair
Light Blue
H67 / C115

D Rouge
Red
H3 / C3

C Jaune
Yellow
H4 / C4

Les schémas de camouflage en couleur sont téléchargeables sur notre site
 The camouflage schemes in colour are downloadable through our website
www.from.com



2013.09

FD0009 PZL P.111

CAM. E

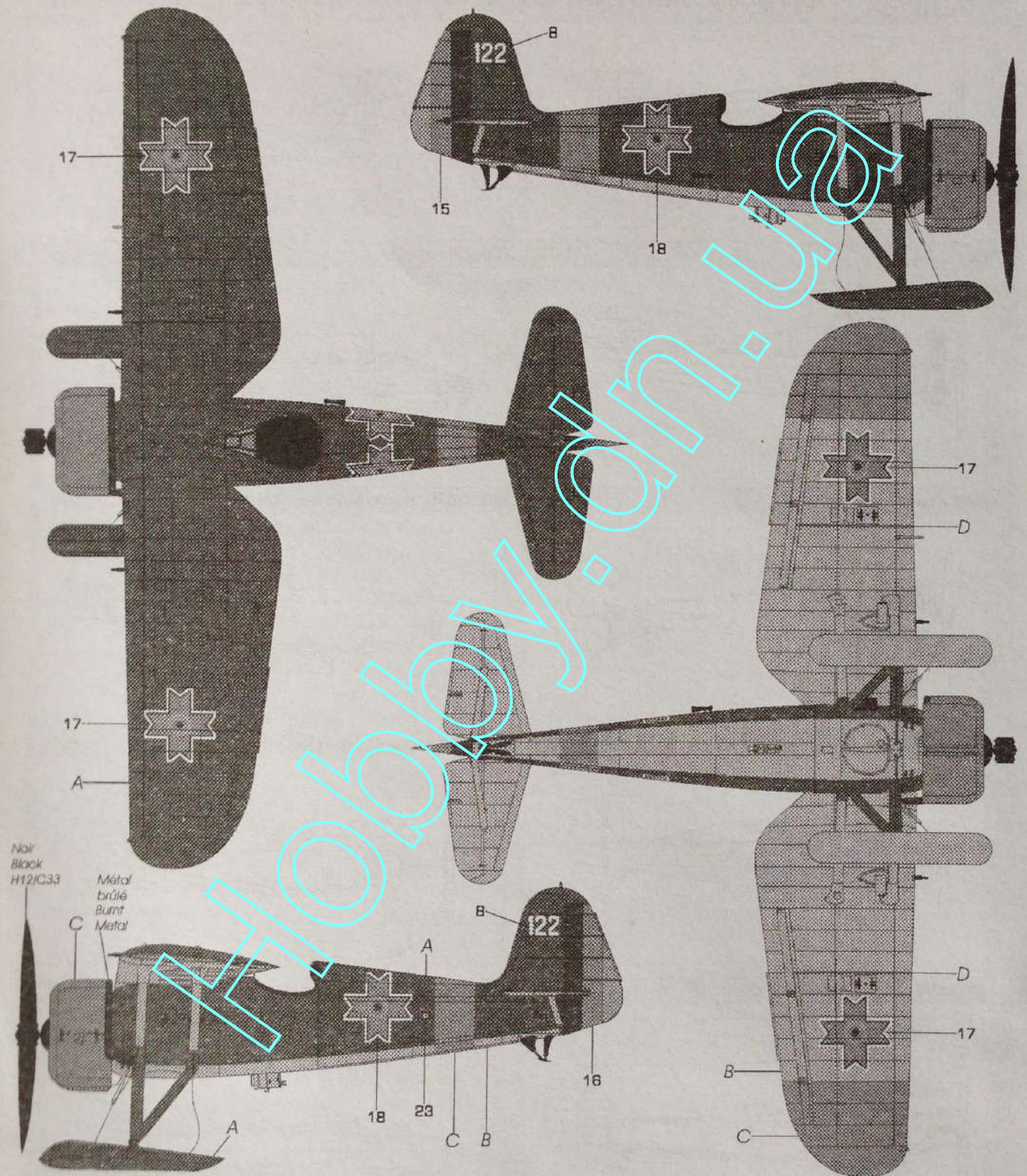

Noir
Black
H12/C33

Métal brûlé
Burnt
Metal

A Brun vert olive
Olive Green
H309 / C309

B Bleu Clair
Light Blue
H67 / C115

D Rouge
Red
H3 / C3

C Jaune
Yellow
H4 / C4

Les schémas de camouflage en couleur sont téléchargeables sur notre site
The camouflage schemes in colour are downloadable through our website
www.from.com



2013/07

FRO023 PZL P.11f

The kit contains decals for following aircraft:

CAMO A

PZL P.11f, Pilot Adjutant Stag.
Av. Ion Dimache, Escadrila 43,
Grupul 3 Vanatoare, Baden airfield,
August 1941.

PZL P.11f, Pilote Adjutant Stag.
Av. Ion Dimache, Escadrila 43,
Grupul 3 Vanatoare, Baden,
août 1941.



CAMO B

PZL P.11f Pilot Adjutant Stag.
Av. Marian Voica, Escadrila
50, Grupul 4 Vanatoare,
Bacoiu Airfield, 1st August 1941.

PZL P.11f Pilote Adjutant Stag.
Av. Marian Voica, Escadrilla 50,
Grupul 4 Vanatoare, Bacoiu,
1er août 1941.

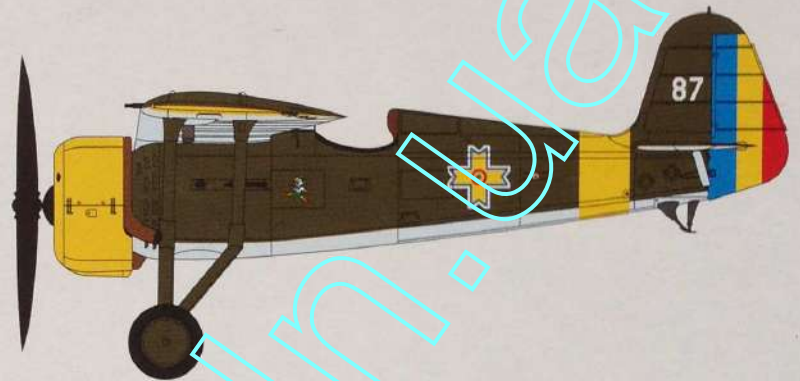

CAMO C

PZL P.11f, Pilot Serg. TR Av. Romeo
Neacsu, Escadrila 43, Grupul
3 Vanatoare, Baden Airfield,
October 1941.

PZL P.11f, Pilote Serg. TR Av. Romeo
Neacsu, Escadrilla 43, Grupul 3
Vanatoare, Baden, octobre 1941.

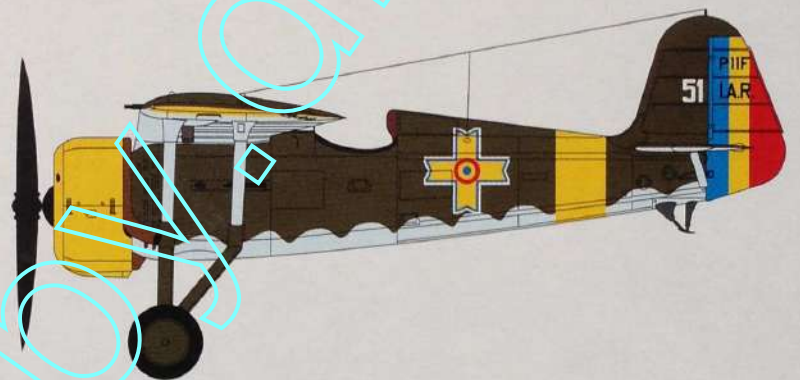

CAMO D

PZL P.11f, Grupul 3 Vanatoare,
Baden airfield, Summer 1941.

PZL P.11f, Grupul 3 Vanatoare,
Baden, été 1941.

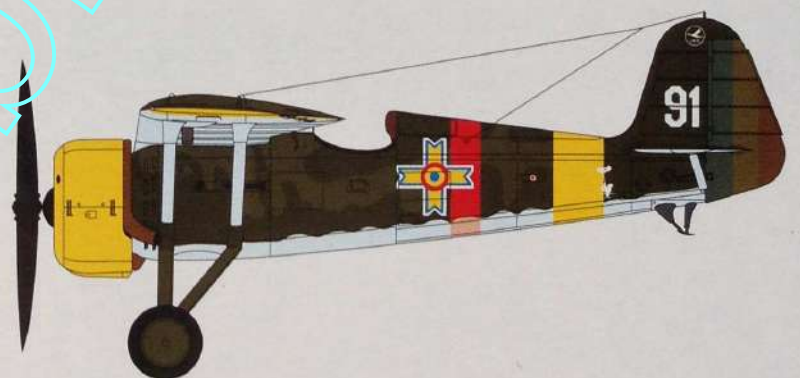

CAMO E

PZL P.11f, Test Squadron,
Pipera airfield (Bucharest),
winter 1941-1942

PZL P.11f, escadrile
d'expérimentation,
Pipera (Bucarest), hiver 41-42

