

# Pl. Kpfw. IV Ausf. G



MID/LATE 2 in 1

ドイツ IV号戦車 G型 (中/後期型)



**x2**

**F**

**J**

**C**

**G**

**H**

**K**

**D**

**E**

**P** (Photo etched Parts)

(Photo etched Parts)

**x2**

**Metal**

**Metal**

**x6**

注: 金属件首批限量



## Panzer IV Ausf.G

The German Panzer IV was originally used as a fire support vehicle for the Panzer III. Because the design of the Panzer III was mainly designed to deal with the battle between the tanks, the hull designed was too compact and the upgrade potential was limited, so when faced with the Soviet Union's T-34, the German design department were forced to go up and down the fourth tank with greater potential to against the "T-34 crisis." The Panzer IV began to use long barrel guns from F2 models. Soon after, the F2 models was classified as the Panzer IV G initial type. The Panzer IV were welcomed by the frontline troops. In the winter of 1942, the armored divisions consisting of these Panzer IV were engaged in combat against the Soviet Union. However, the thickest part of the armor of the Panzer IV, which was originally used as a fire support vehicle, was only 50mm, so its defense power was too weak. Therefore, in the subsequent production process, the front armor of the Panzer IV was thickened from the previous 50mm to 80mm, and the added 30mm was attached to the vehicle body as an additional armor welding (riveting). The improvement of the G models continued. In the spring of 1943, the Germans replaced the original L43 gun with a more powerful L48 75mm gun. In addition, in view of the heavy use of anti-tank rifles and the Bazuka rockets during this period, the Panzer IV G also installed additional armor (skirts) around the side of the hull and around the turret. In the Kursk battle, the Panzer IV G was the main force.

德军的四号坦克，最初是作为三号坦克的火力支援战车而设计。由于三号坦克设计初主要为了应对坦克间的交战，车身设计过于紧凑，改装潜力有限，所以当面对苏军如潮水般的T-34坦克时，德军设计当局被迫在改装潜力较大的四号坦克上下手，对其性能进行提升以对抗“T-34危机”。四号坦克从F2开始，就开始使用长身管火炮。在不久之后，这批F2型被划归为四号G初期型。这批四号坦克深受前线部队的欢迎，在1942年冬天由这批四号坦克组成的装甲师就投入了对苏作战。但原本作为火力支援战车的四号坦克装甲最厚的部位也只有50mm防御力较弱。因此在后续的生产过程中四号坦克的车身前装甲从之前的50mm加厚到了80mm，增加的30mm作为附加装甲焊接（铆接）在车体之上。四号G型的改进还在继续，在1943年春天，德军使用威力更为强大的48倍径75mm火炮替换了原来的43倍径火炮。另外，鉴于在这个时期反坦克步枪和巴祖卡火箭弹的大量使用，四号G还在车身侧面和炮塔周围安装了附加装甲（裙甲）。在库尔斯克会战中，四号G后期型作为主力参与了此次战斗。





# 1 Assembly of special optional parts

## 特殊的搭载物品组装

OPTIONAL PARTS: ADDITIONAL TRACK FROM THE T34 TANK  
追加装甲はT34クローラーを選択できます

**A** x2

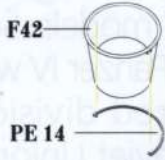

**B** x2

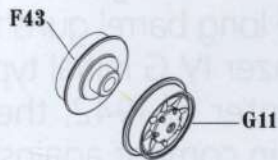

**C** x2

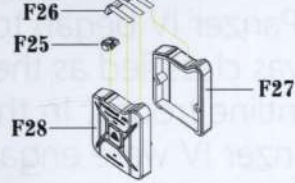

● x10

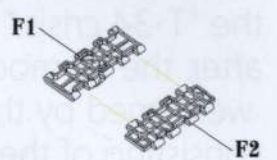

# 2

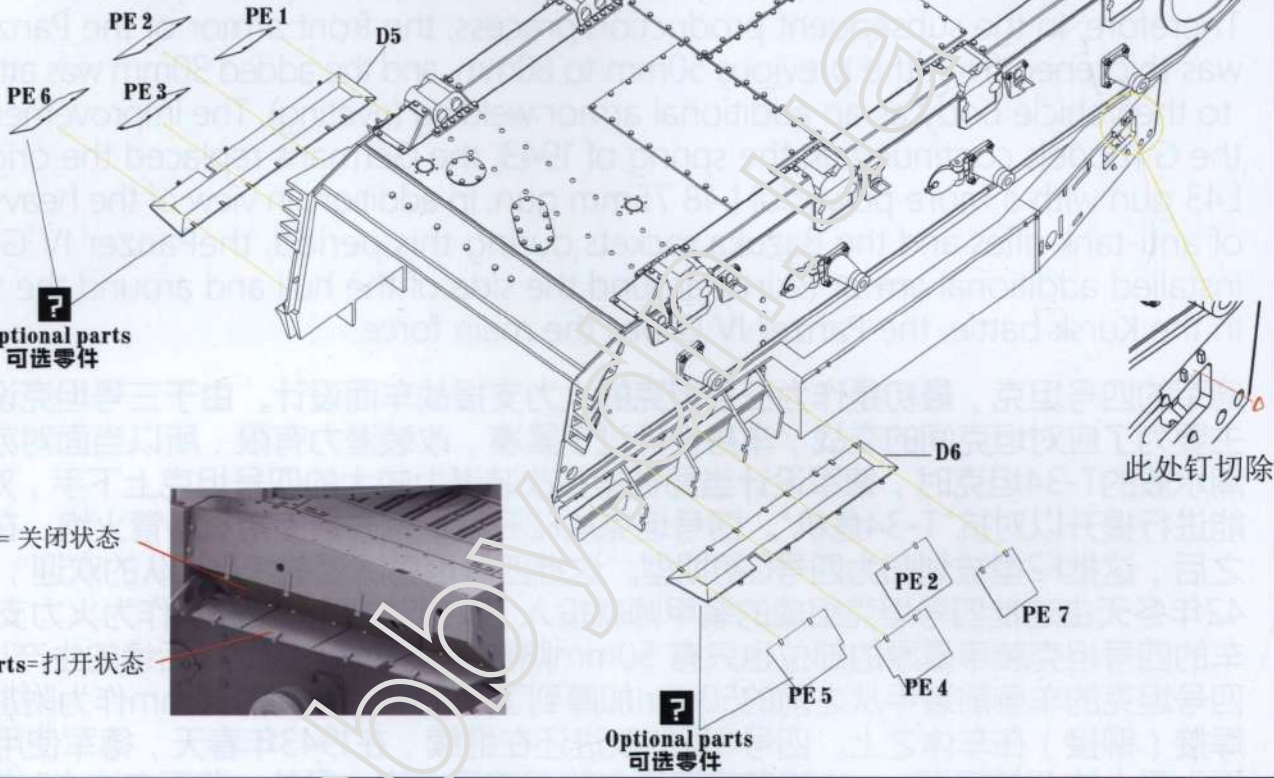

Optional parts  
可选零件

Copper PE= 关闭状态

Plastic parts= 打开状态



Optional parts  
可选零件

此处钉切除

# 3

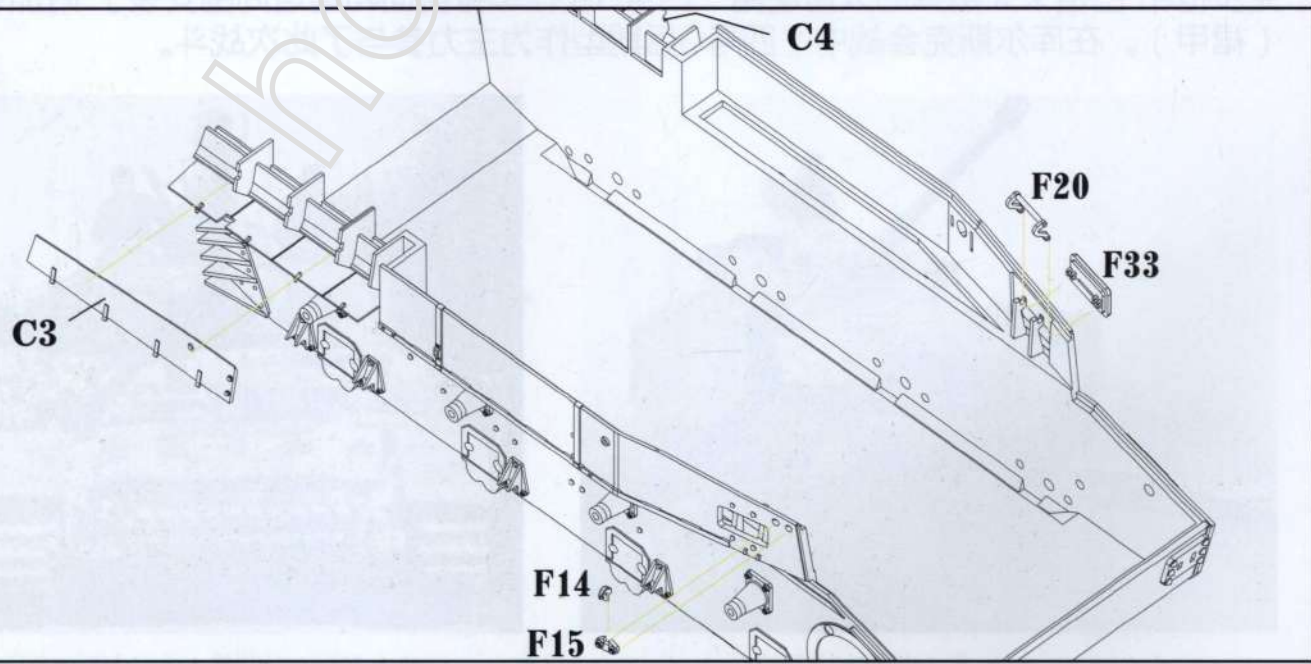

C3

C4

F14

F15

F20

F33



4

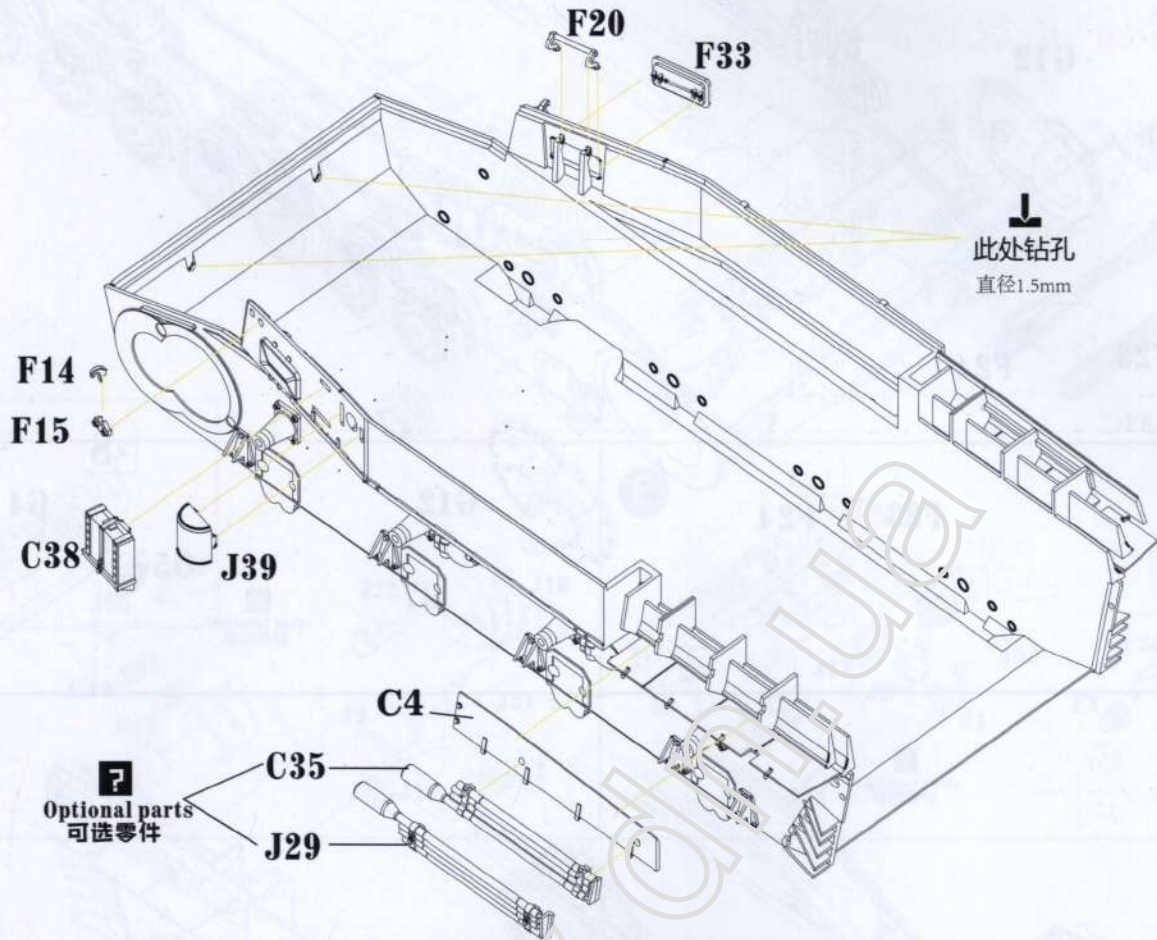

5

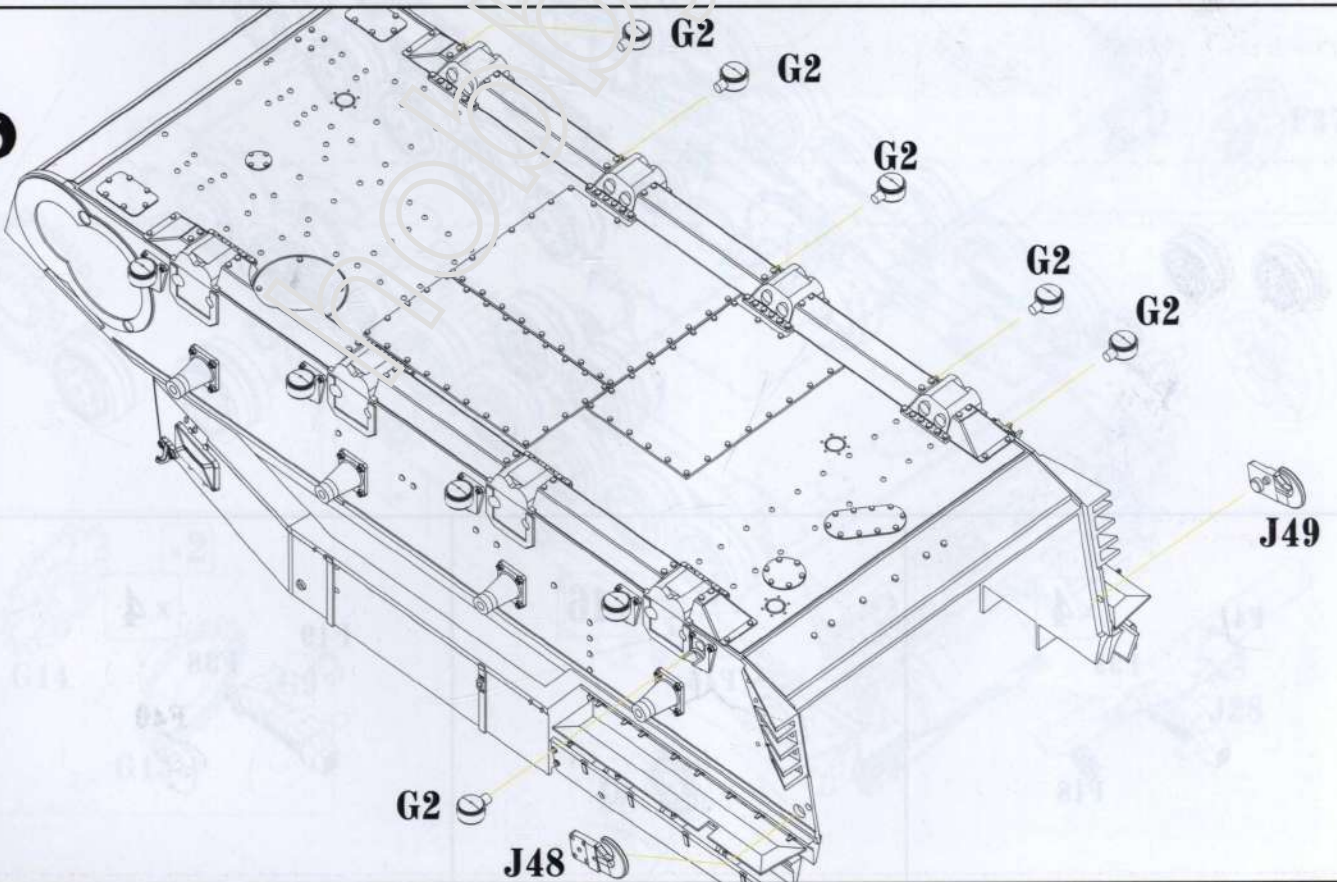



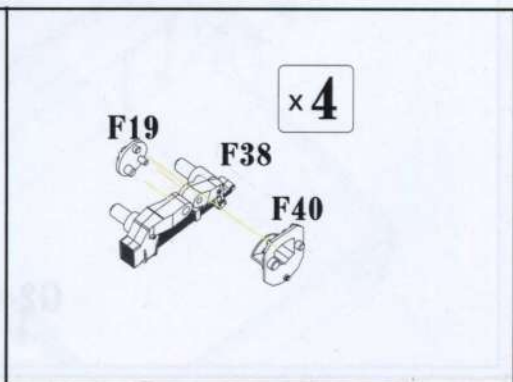
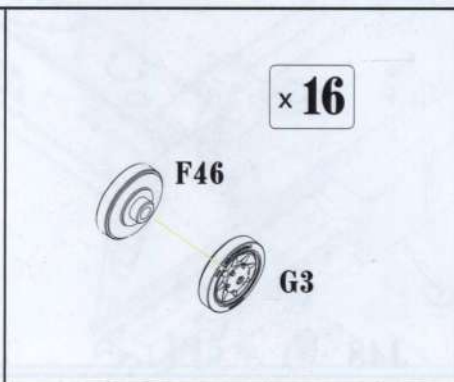
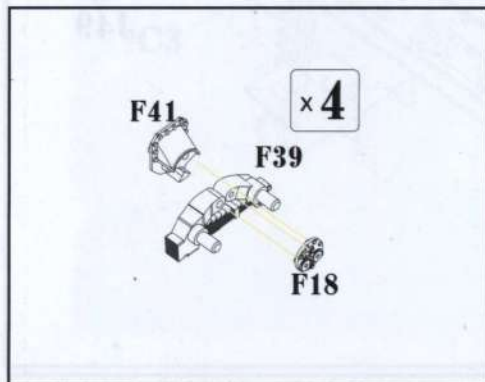
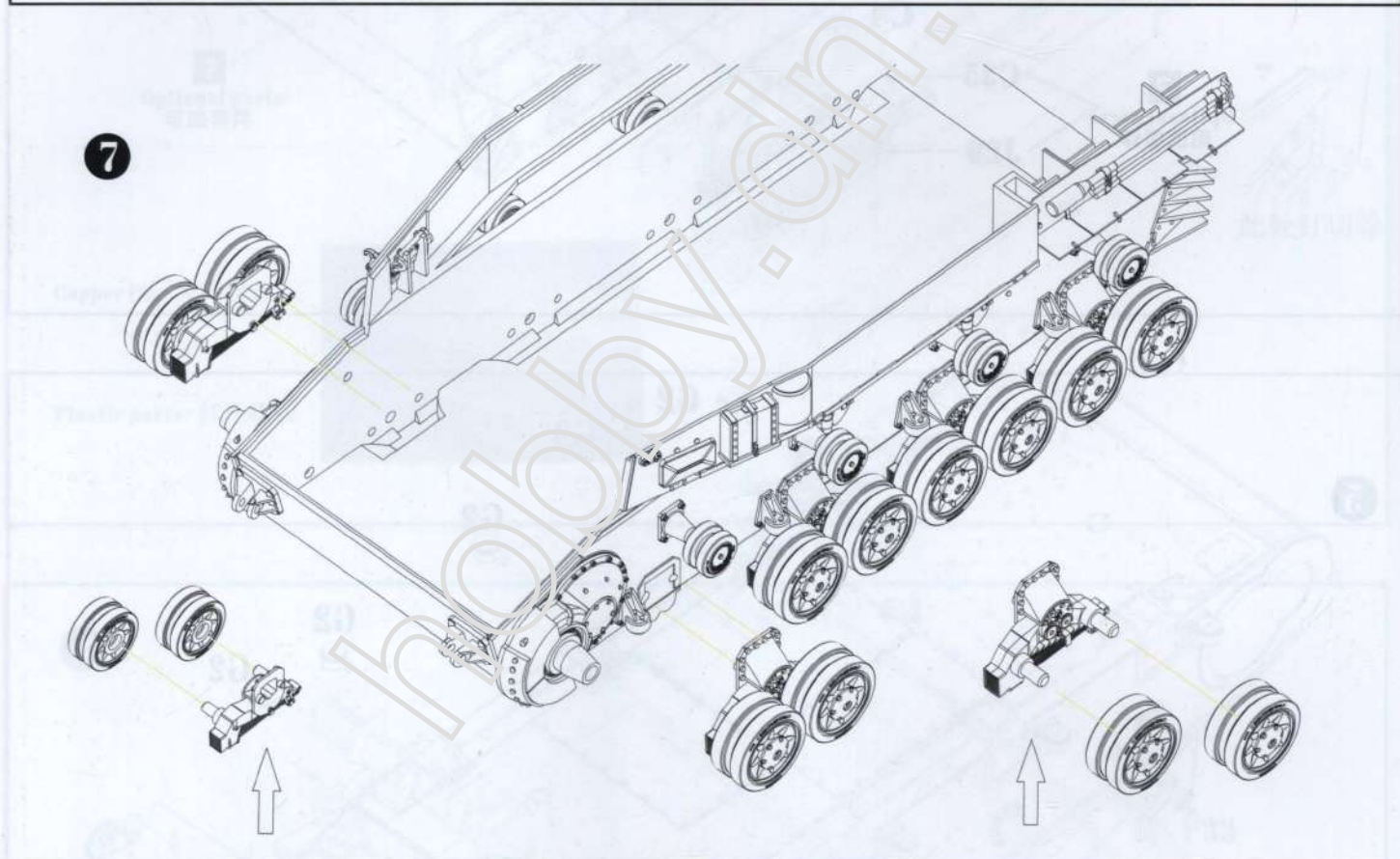
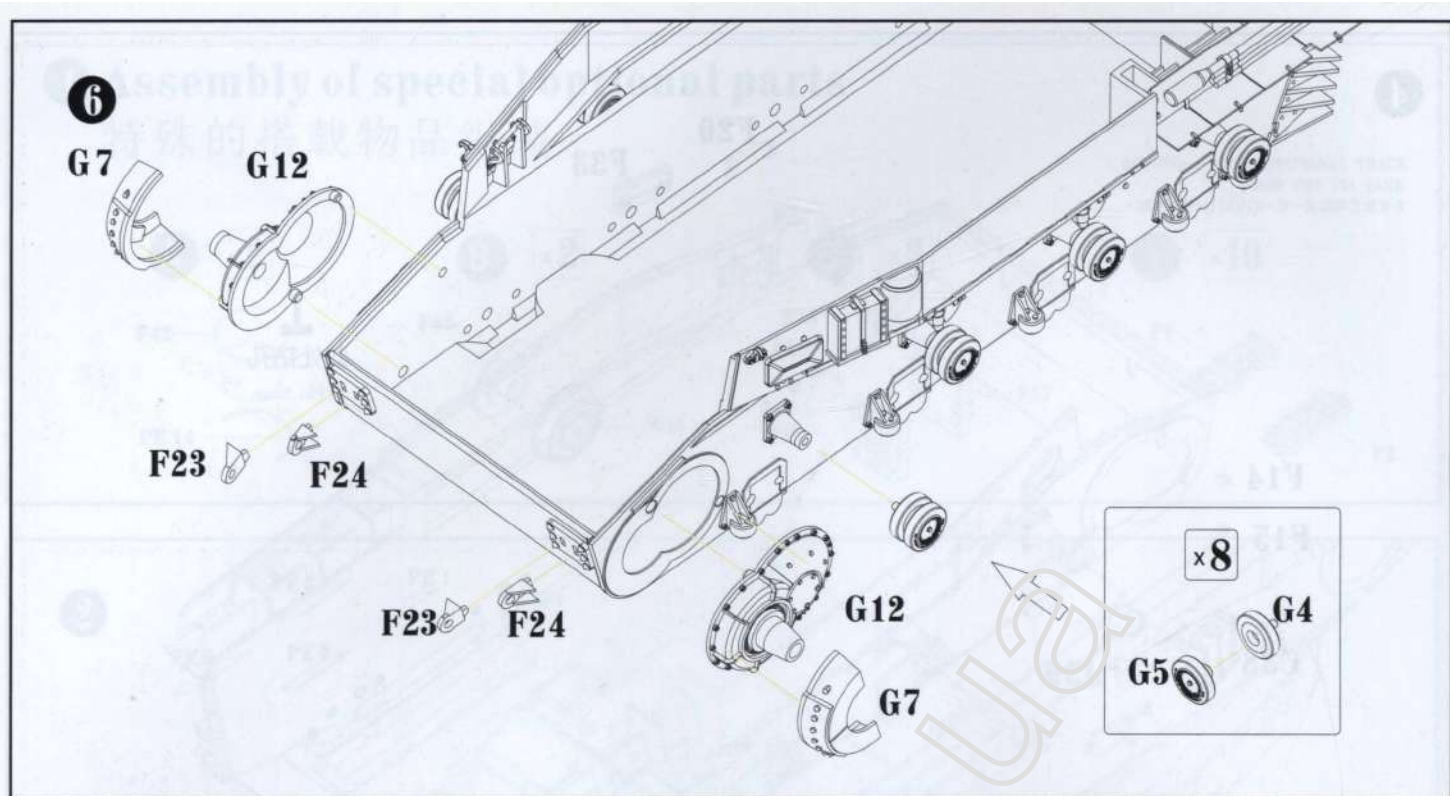



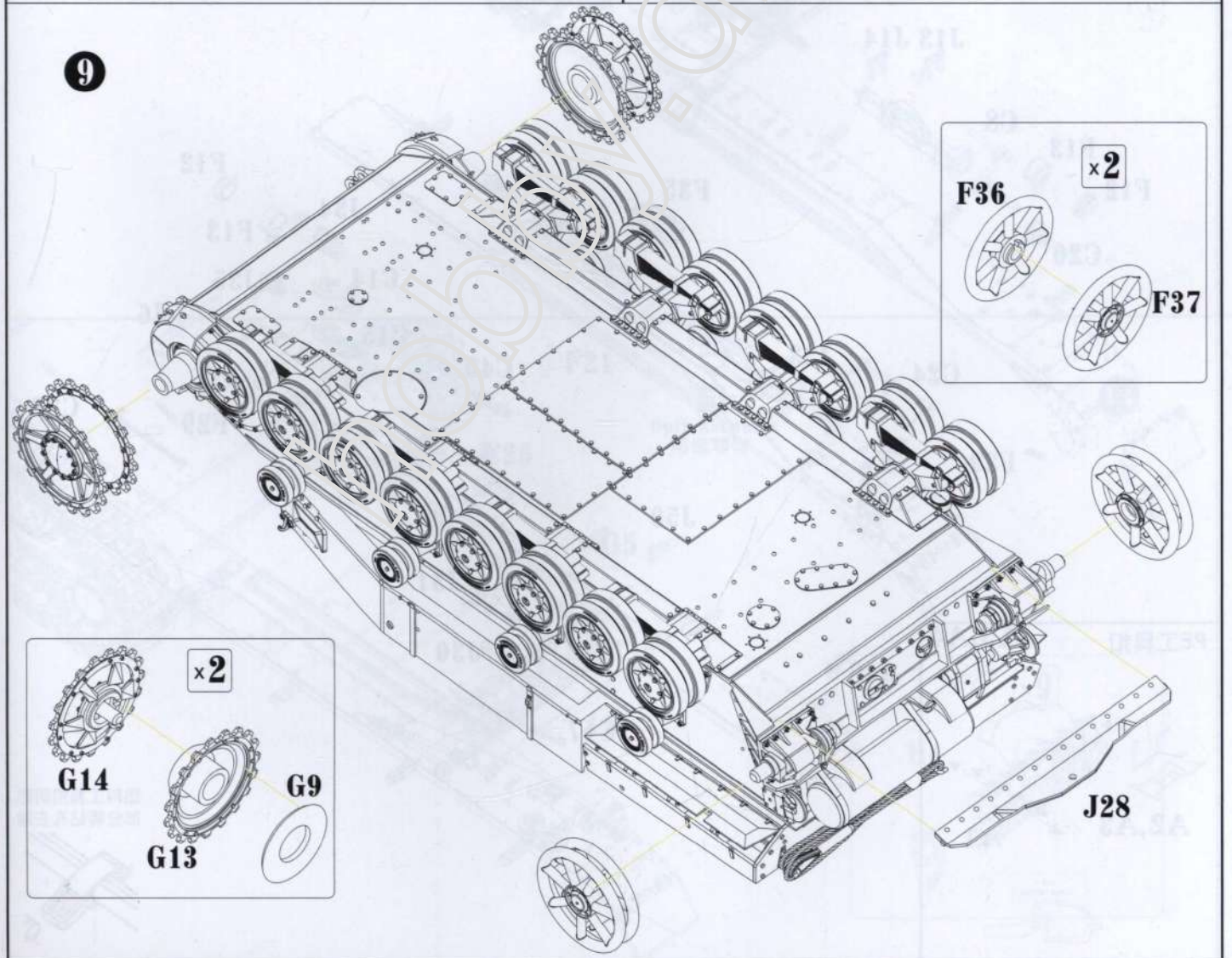
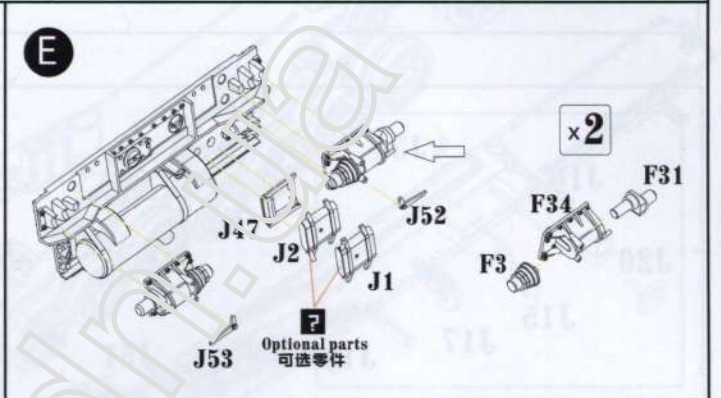
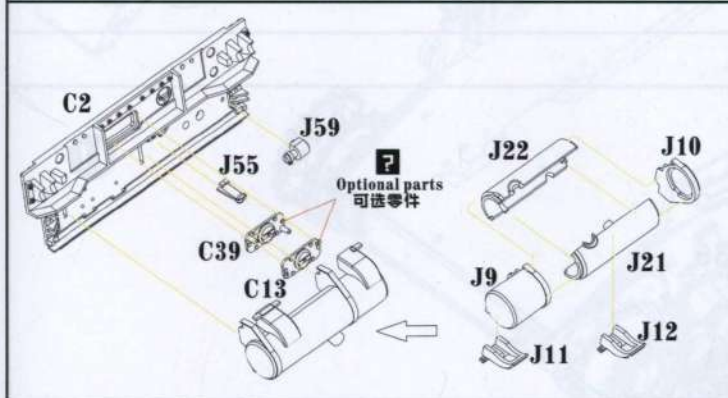
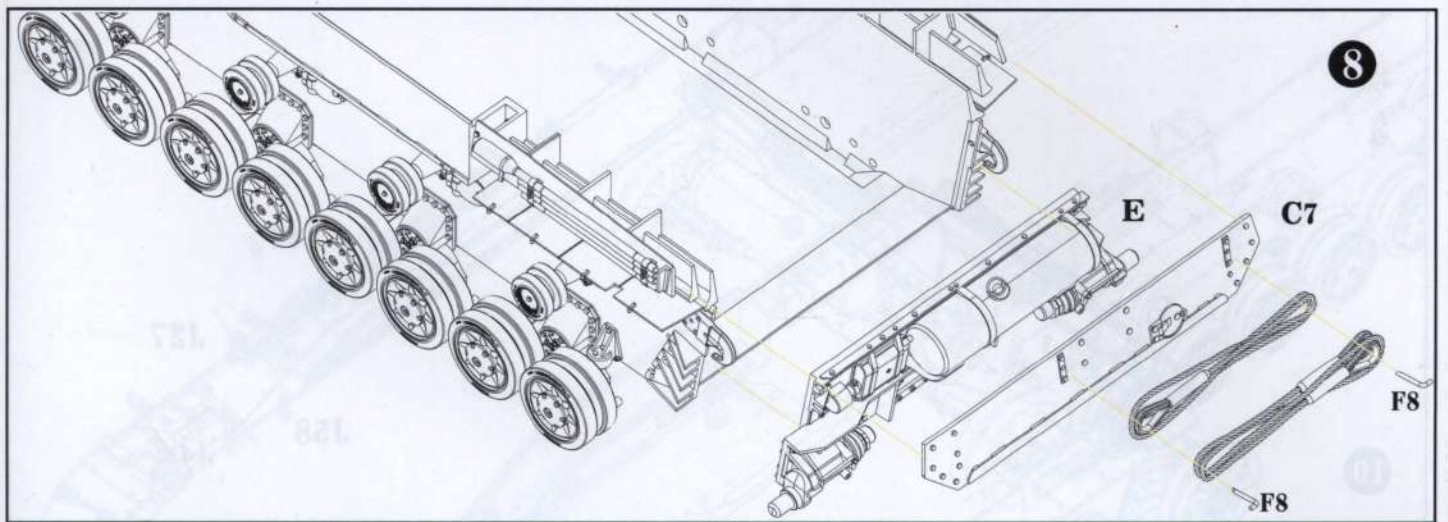



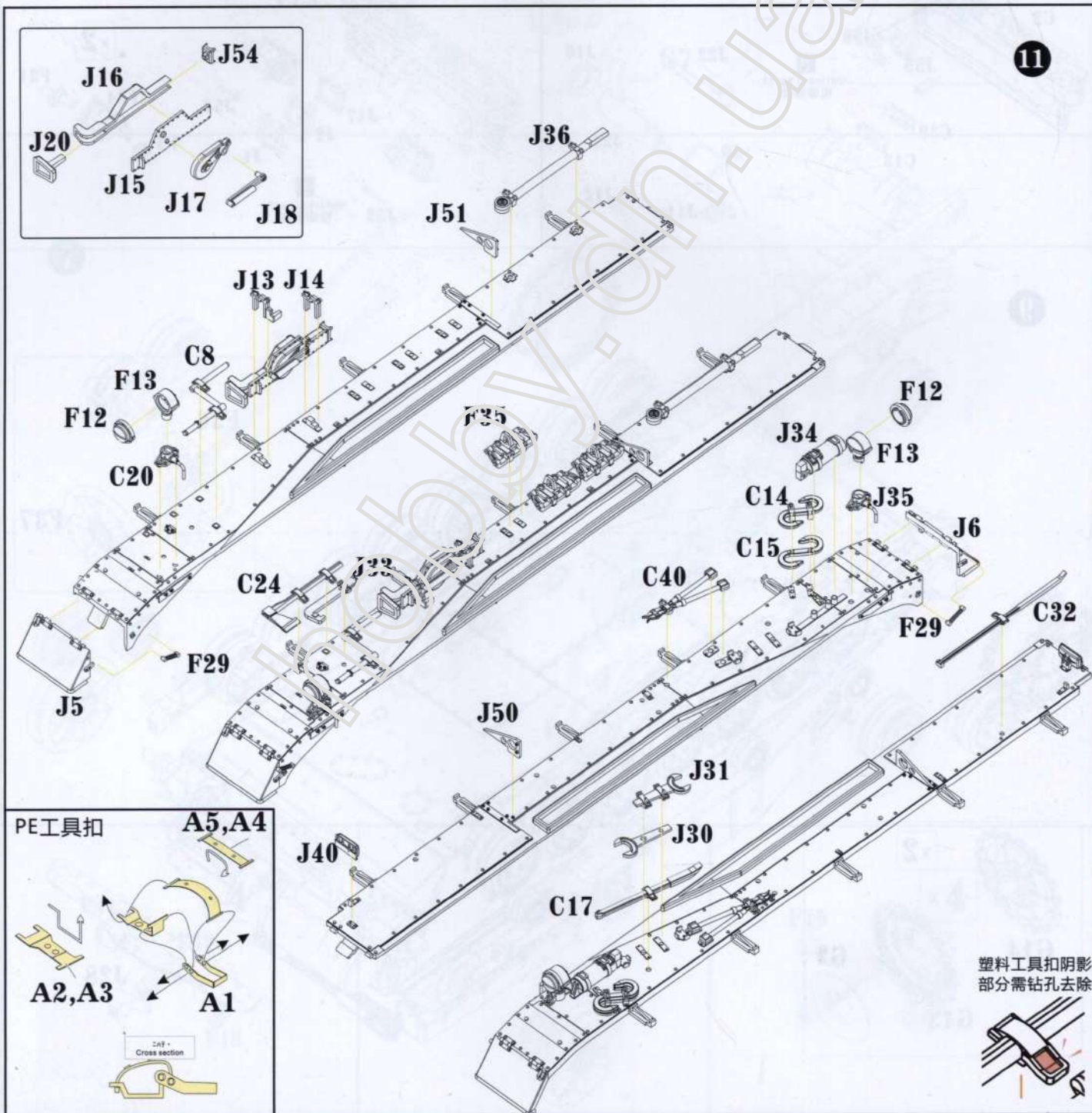
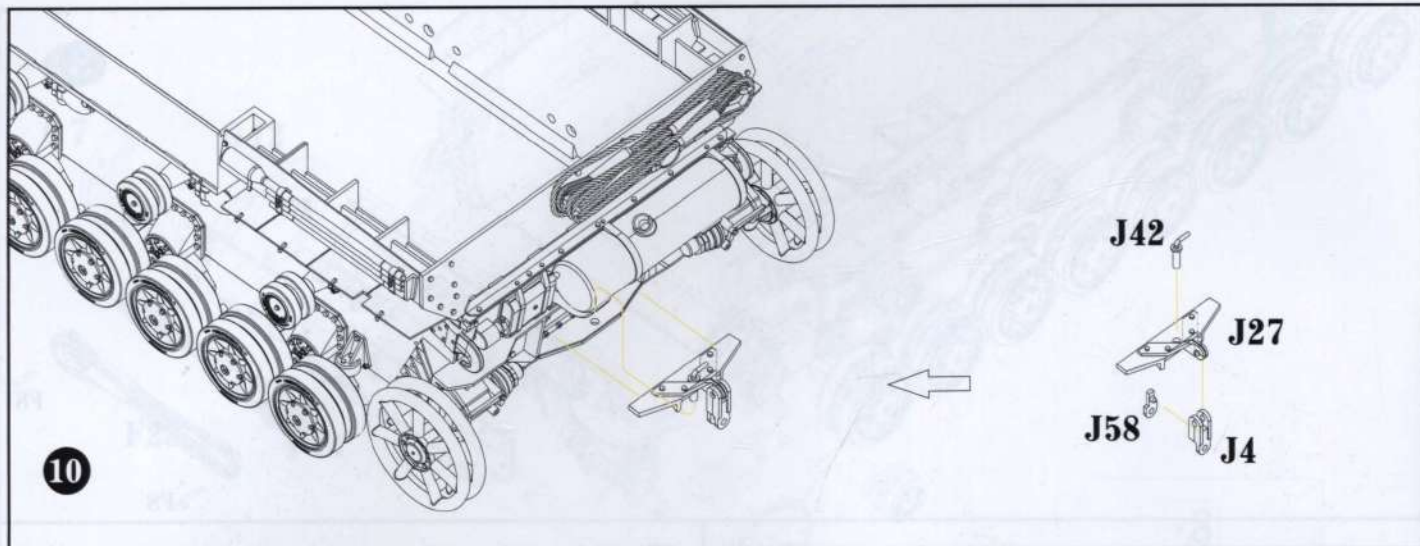



12

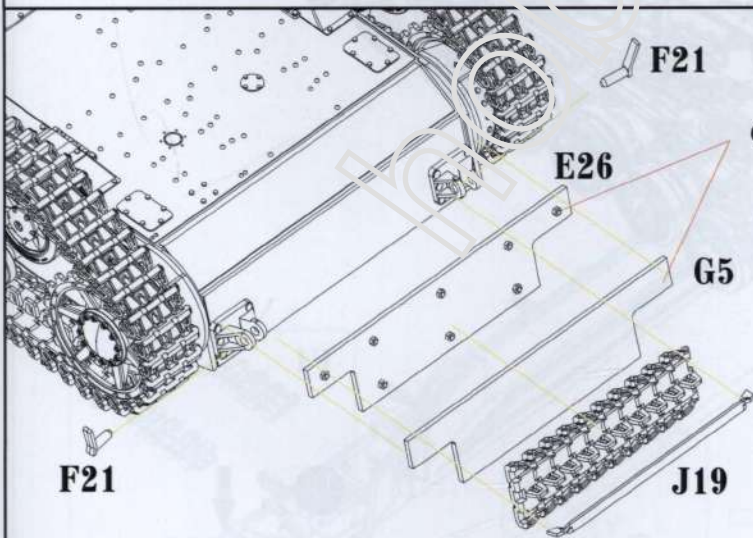
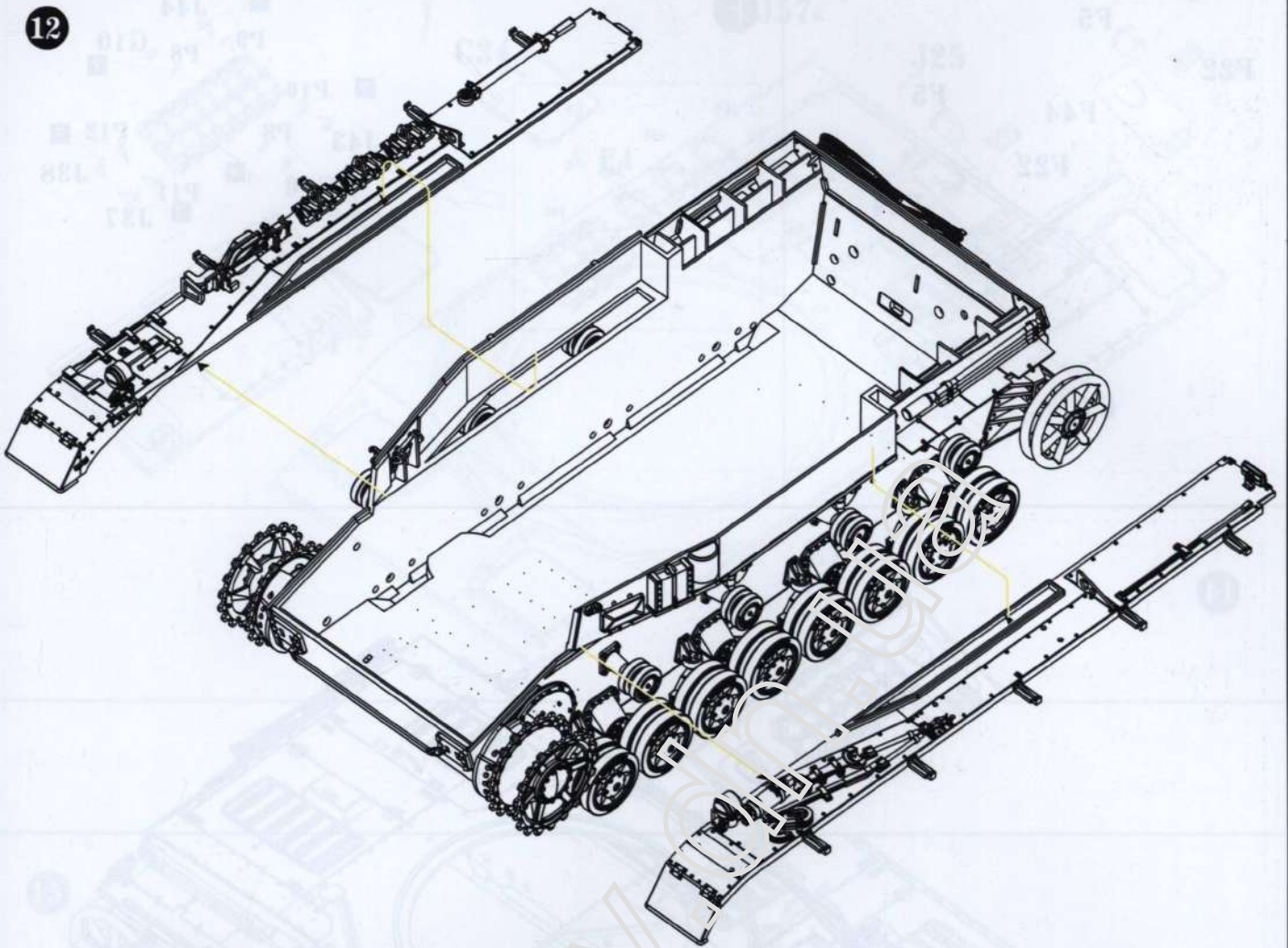

**Optional parts**  
可选零件

13





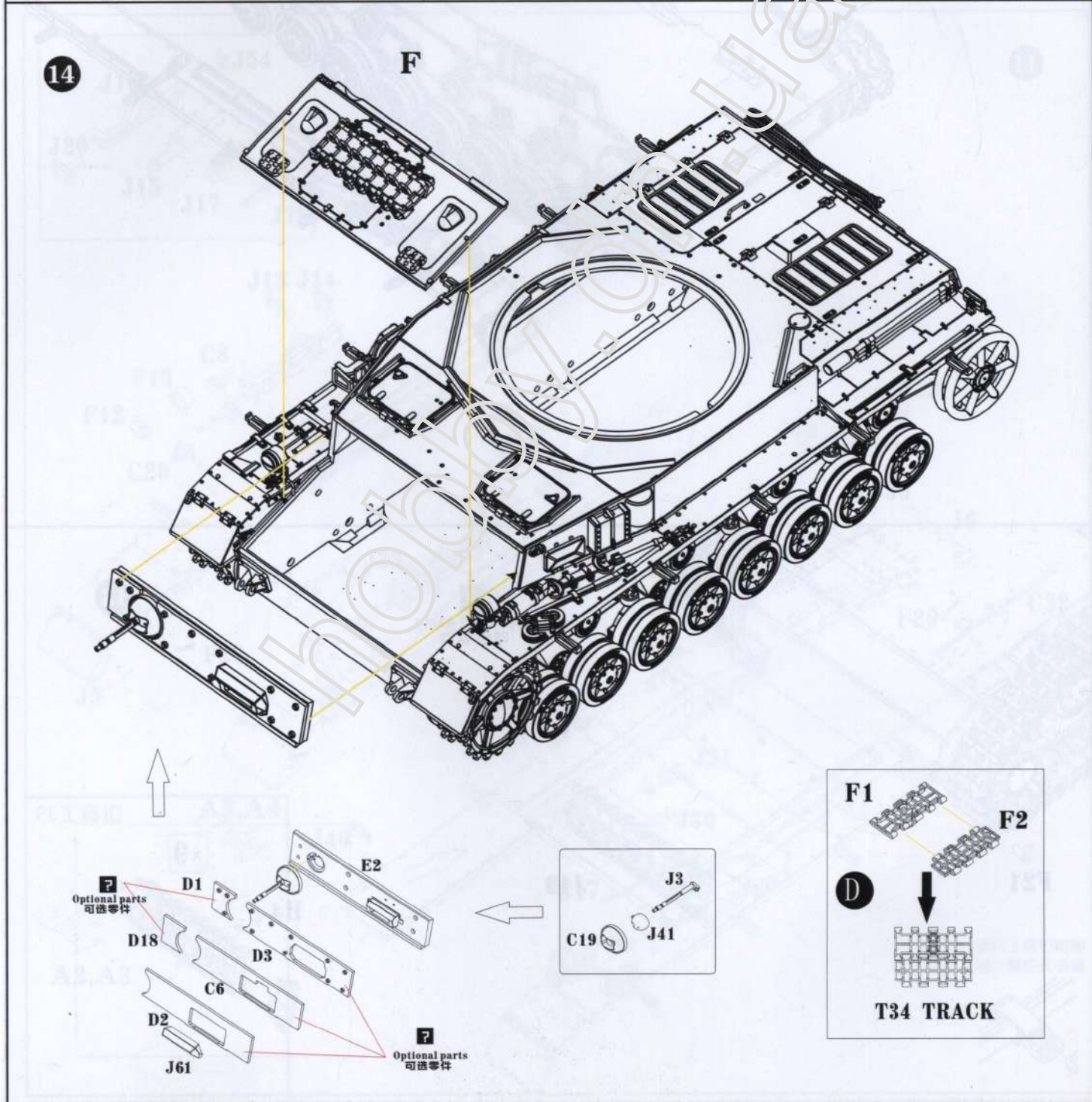
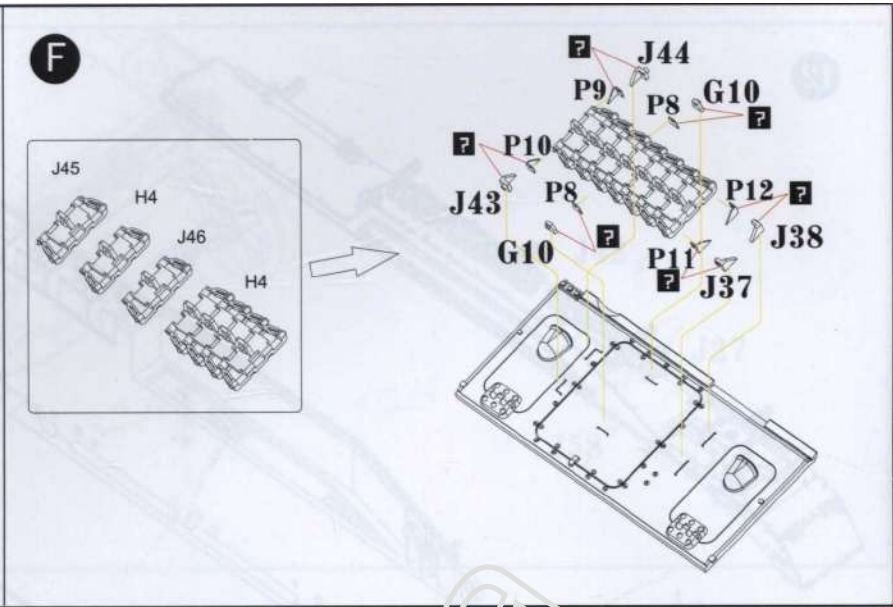
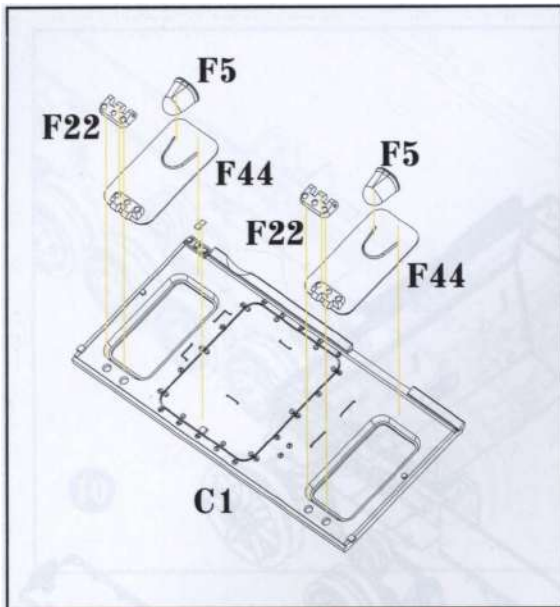



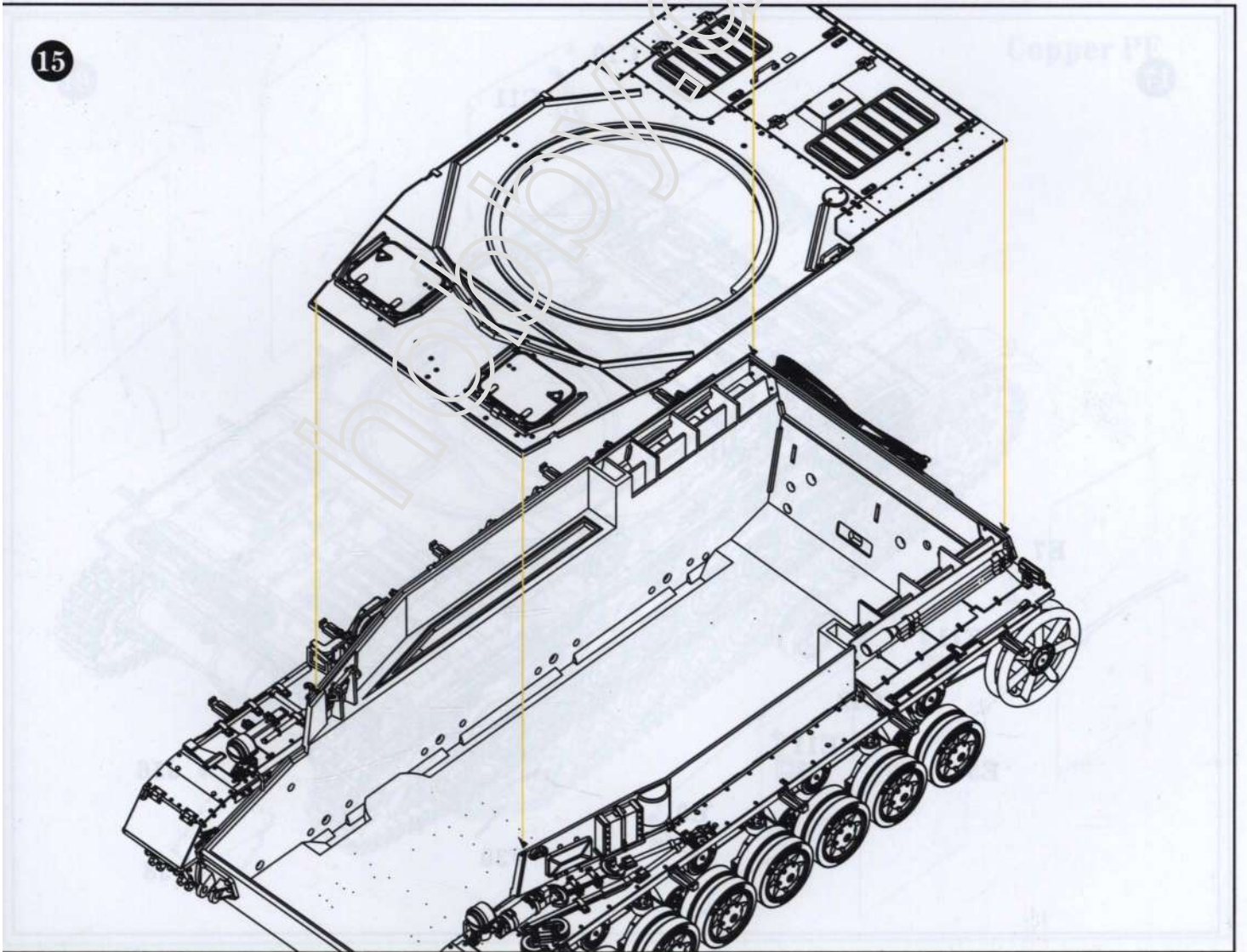
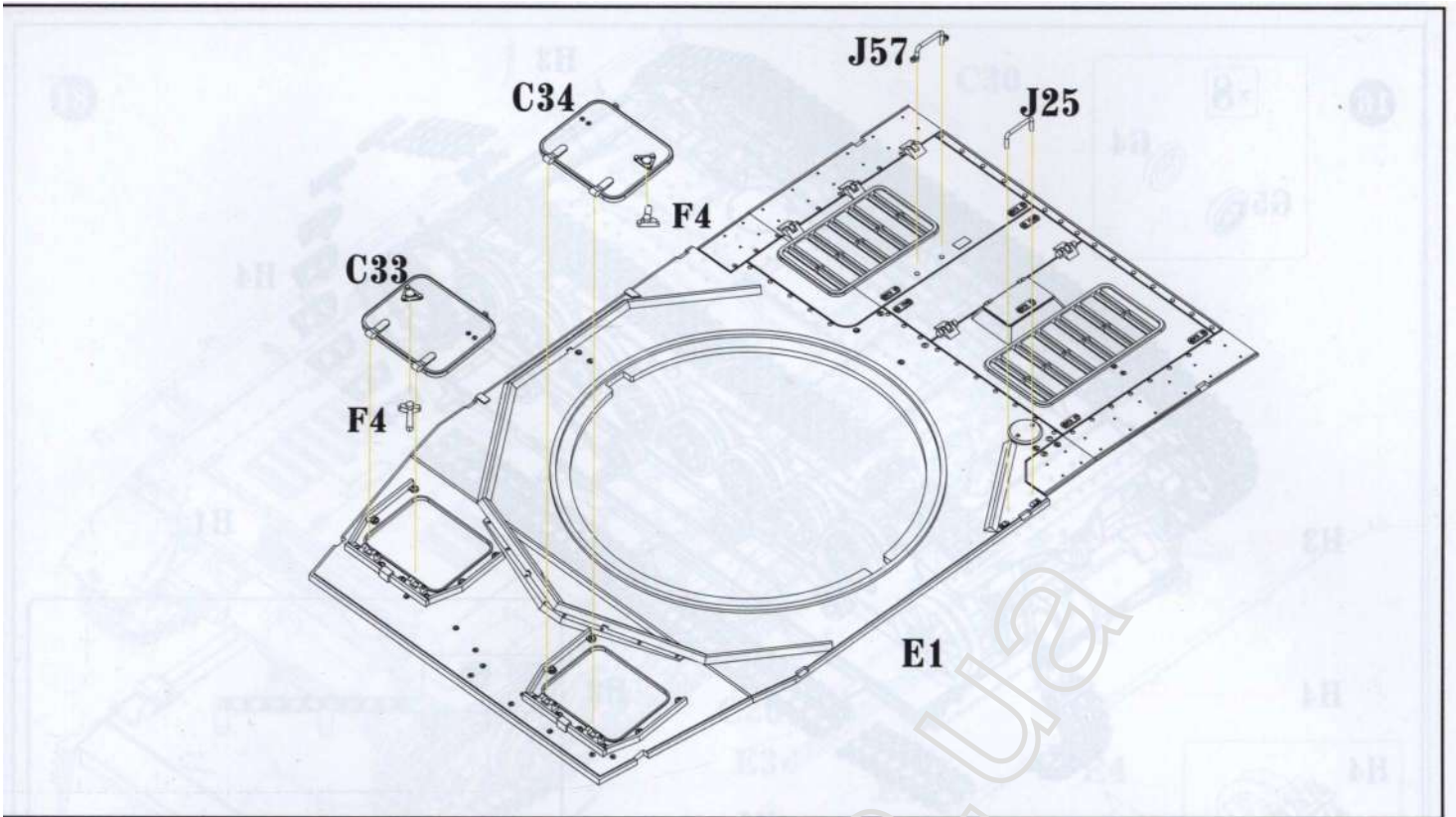



16

x8

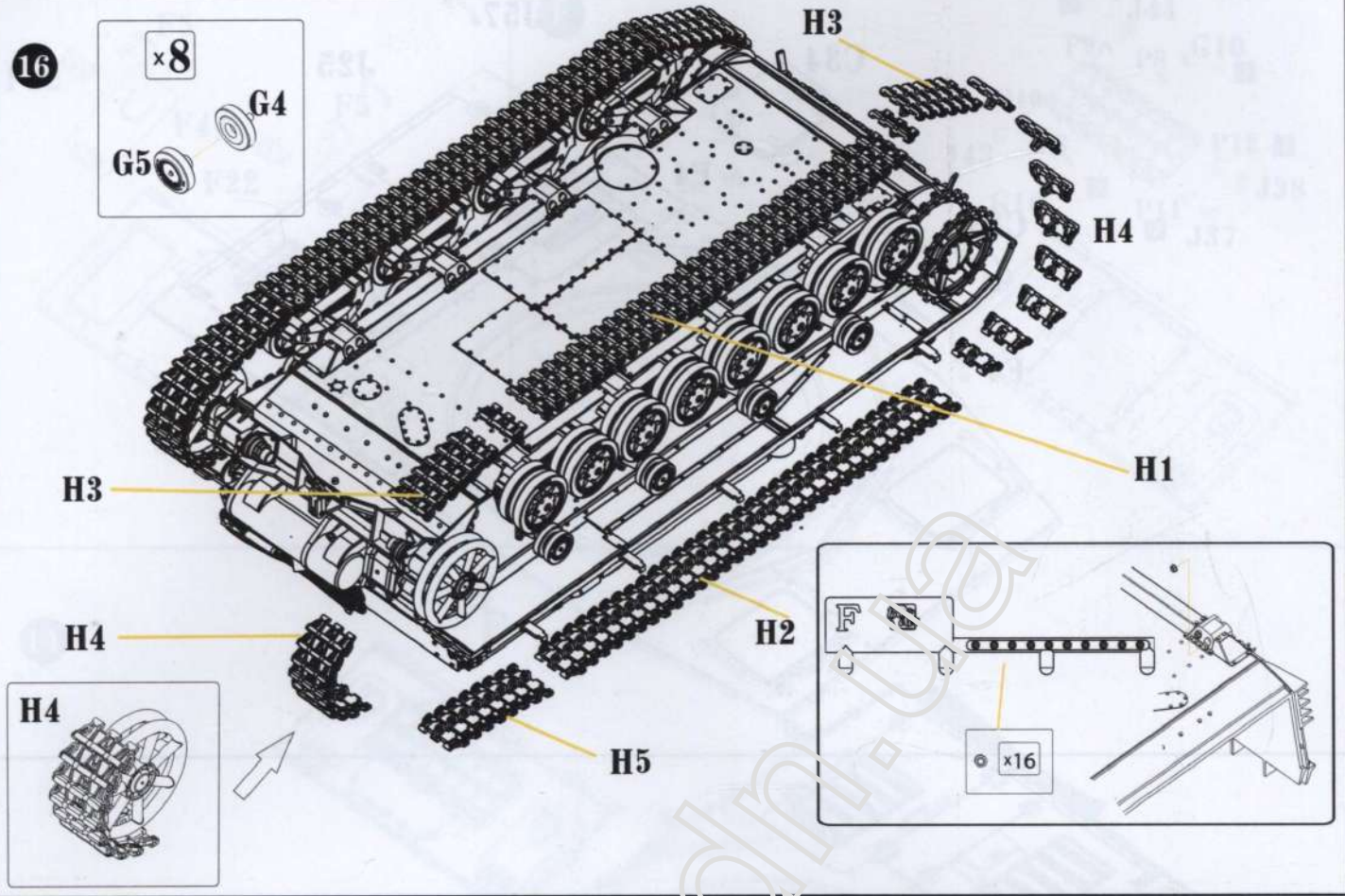

17

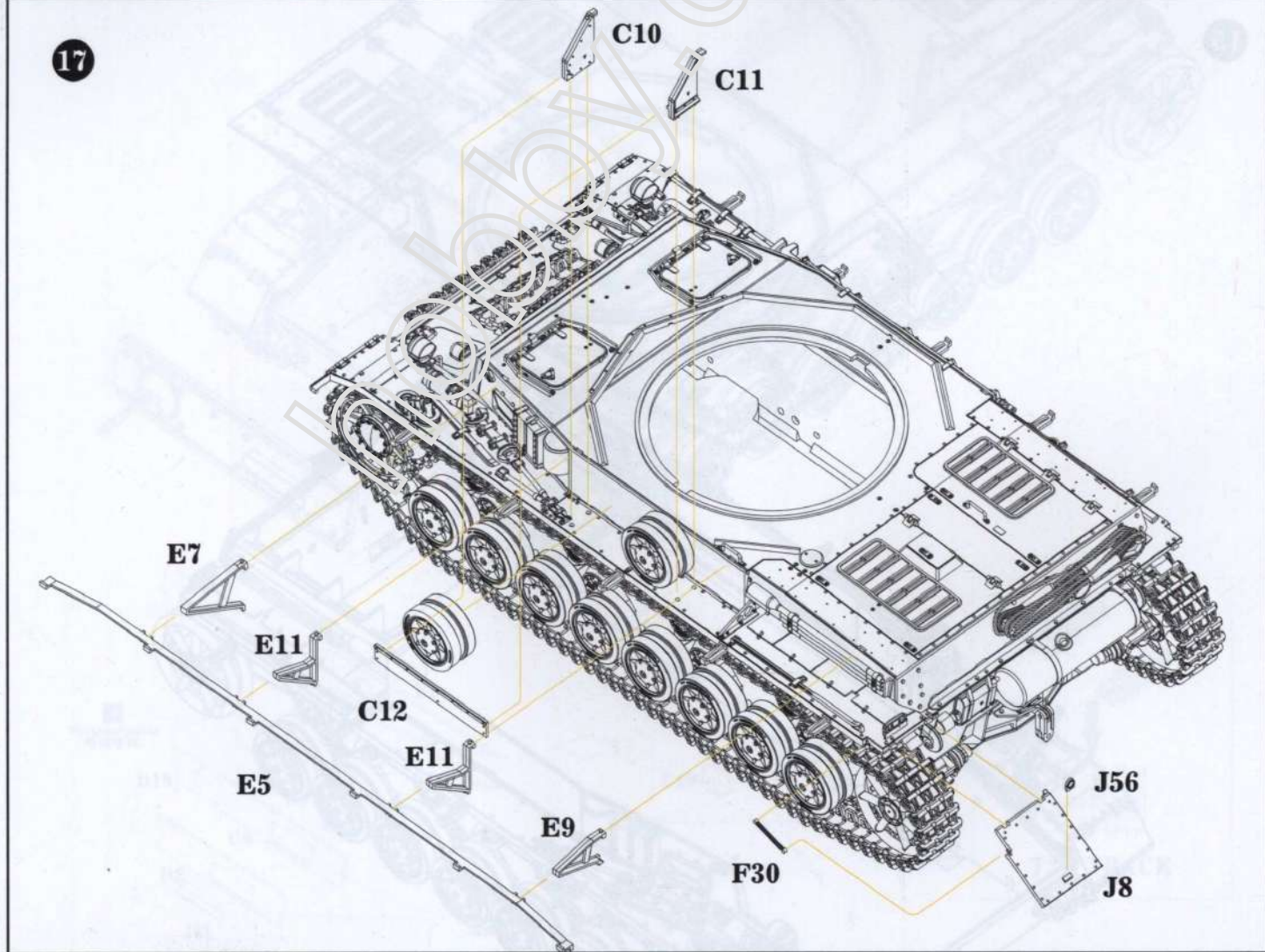



18

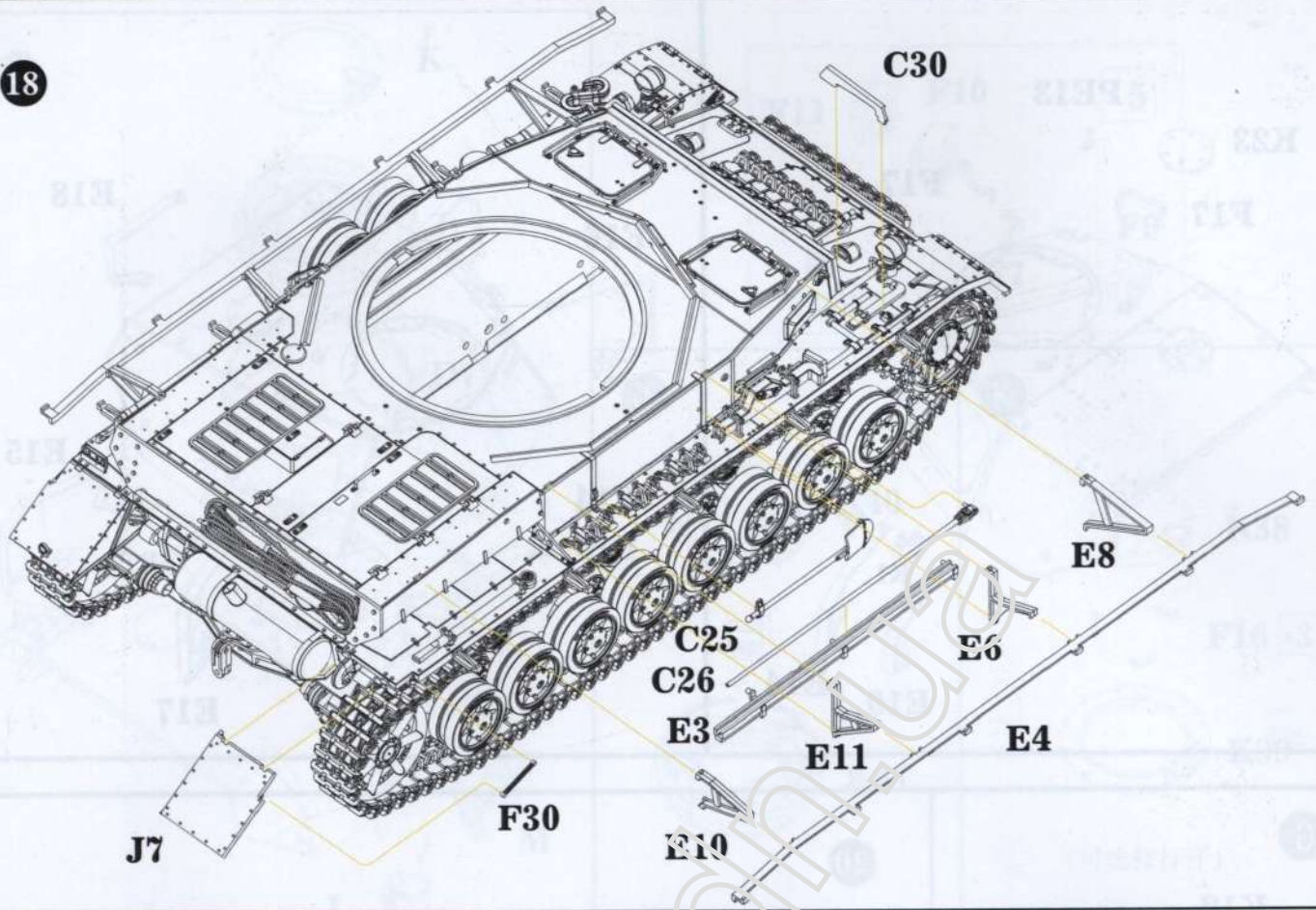

19

Copper PE

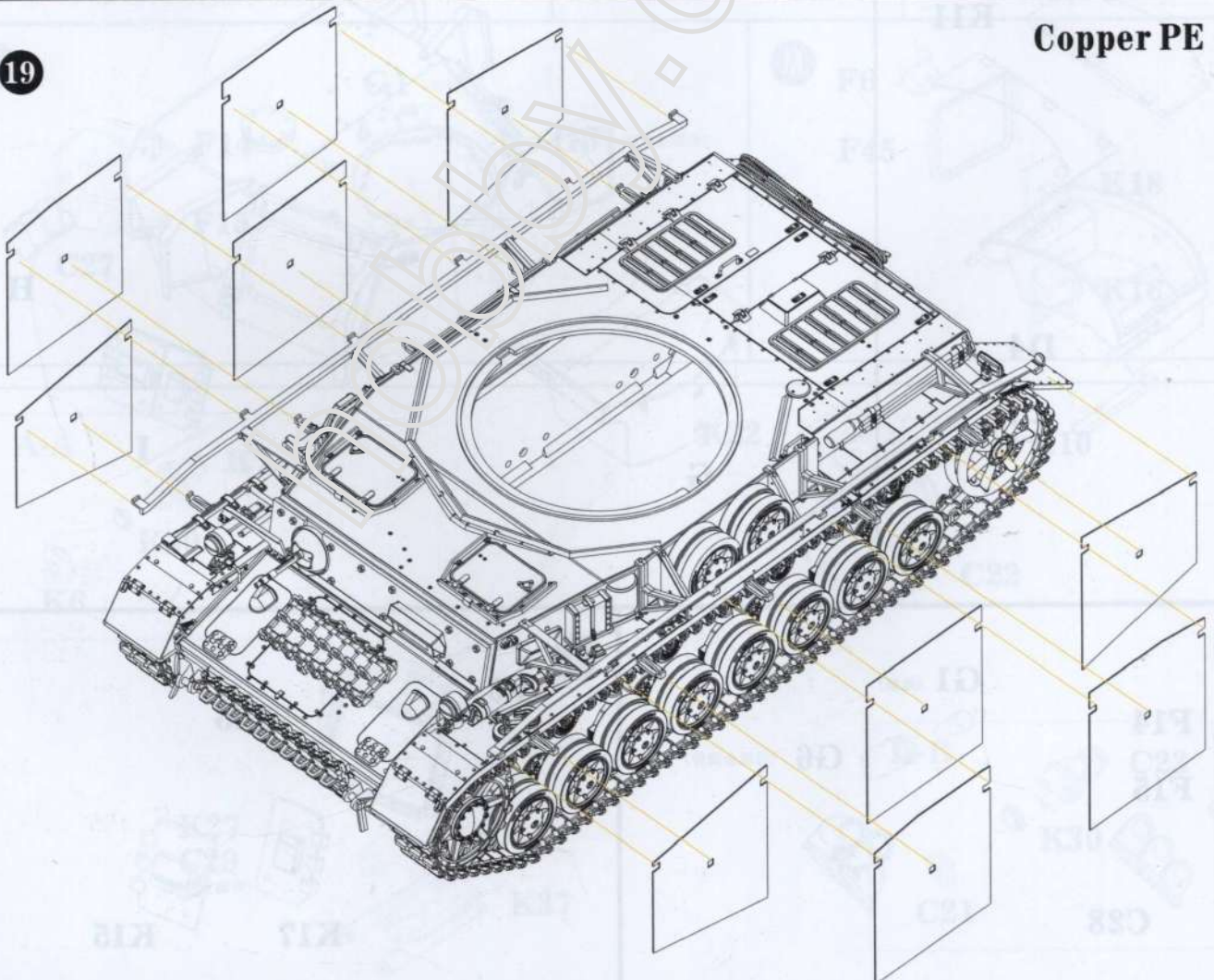



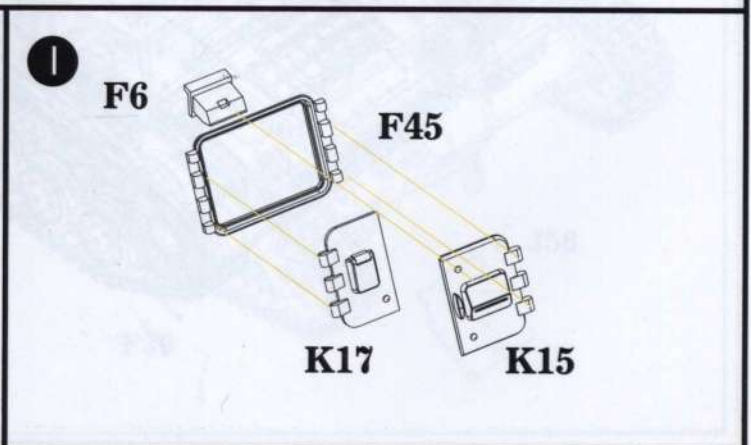
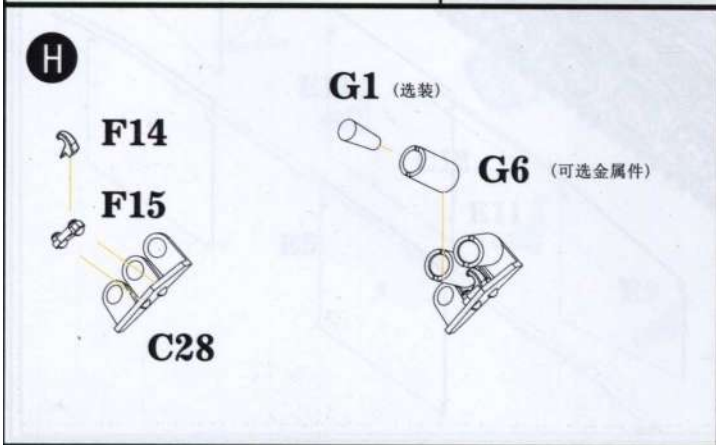
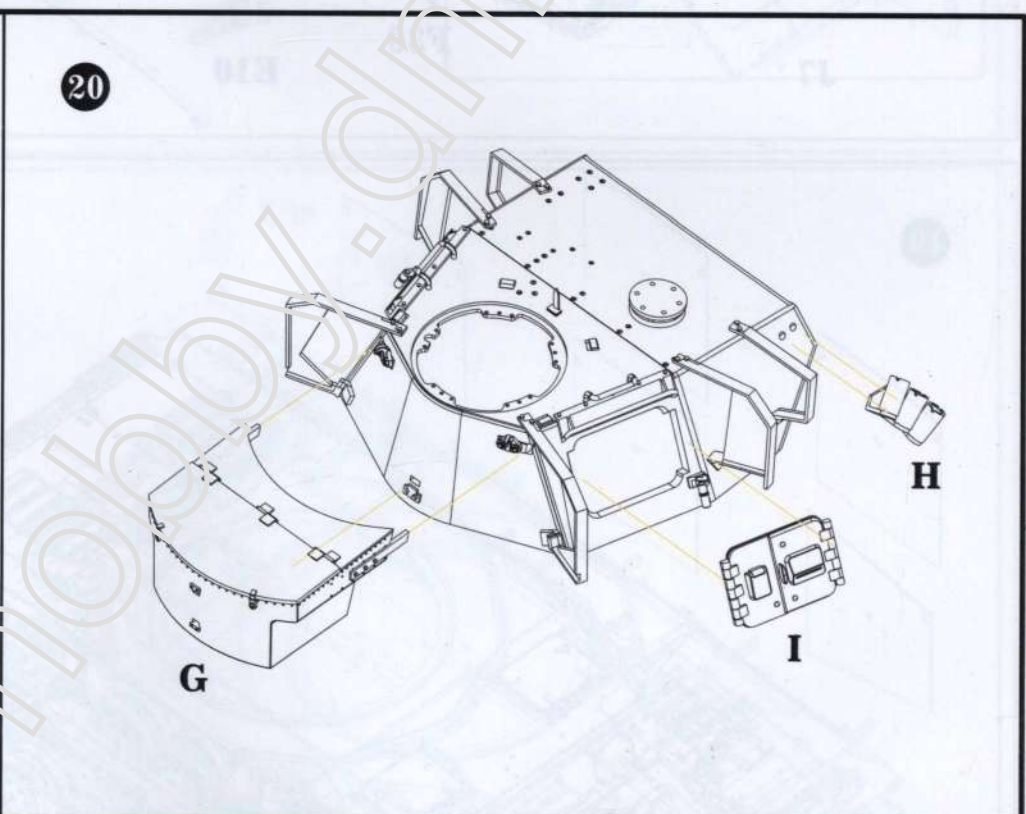
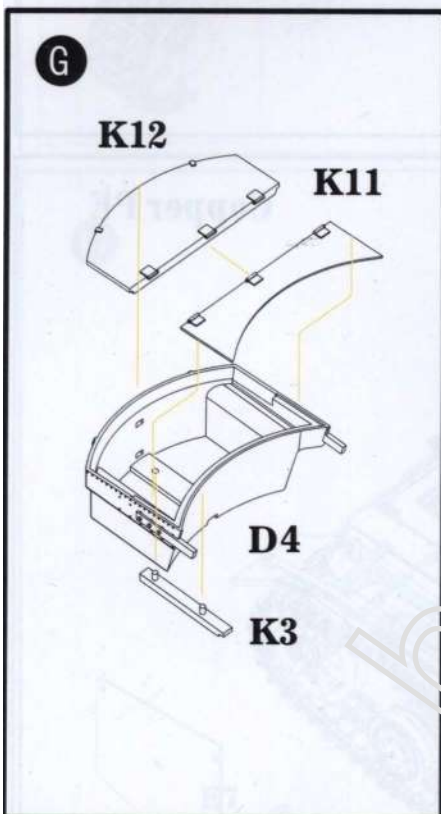
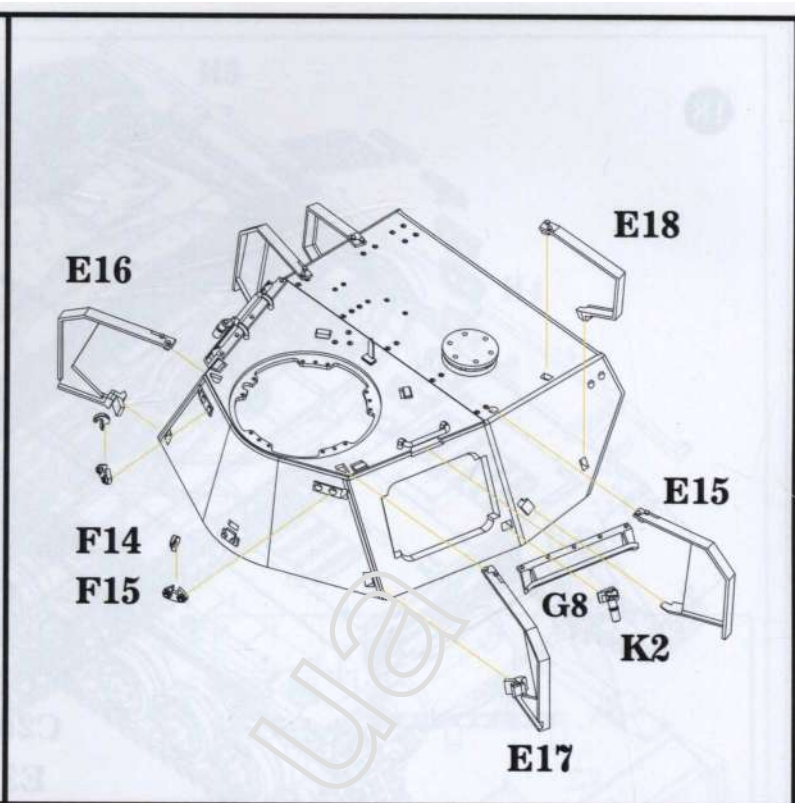
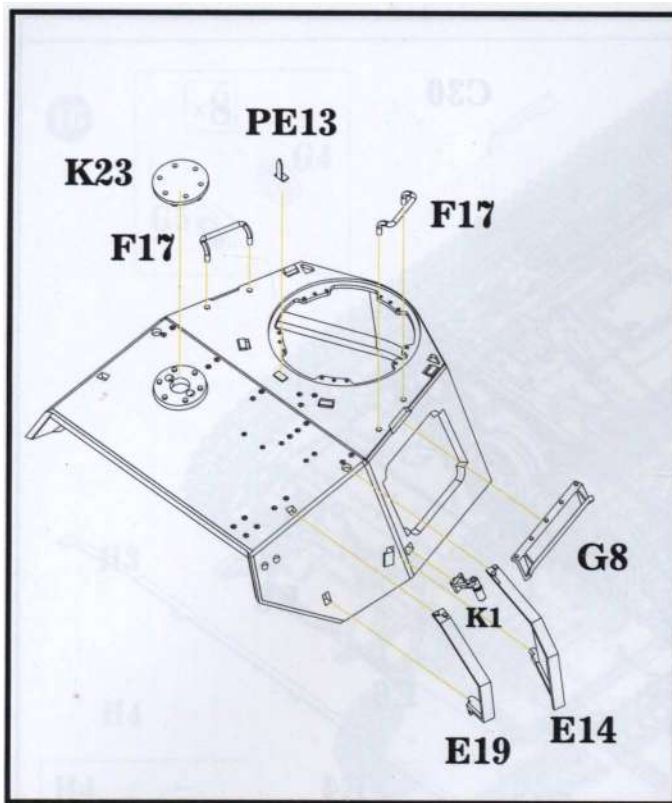



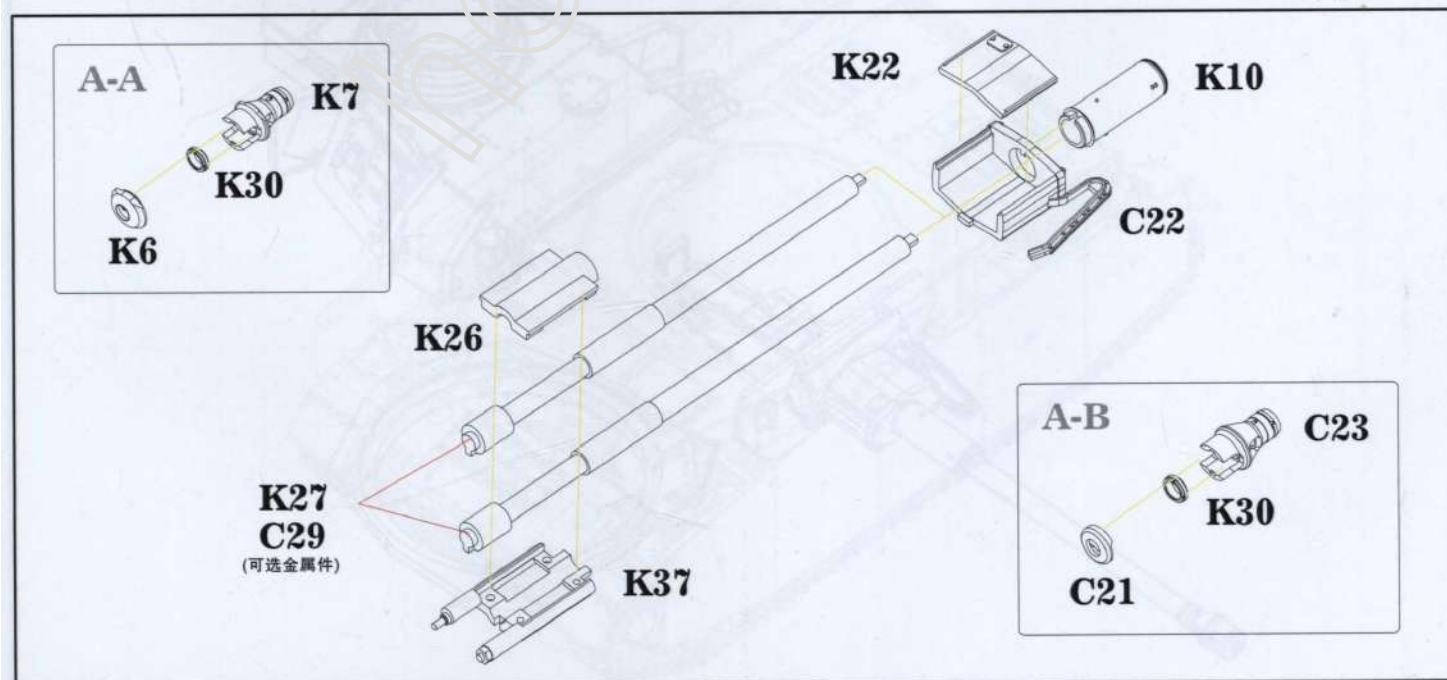
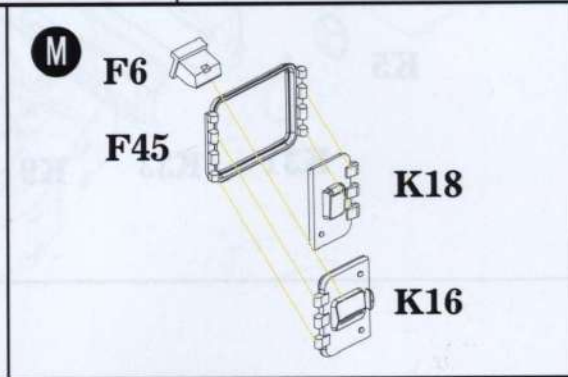
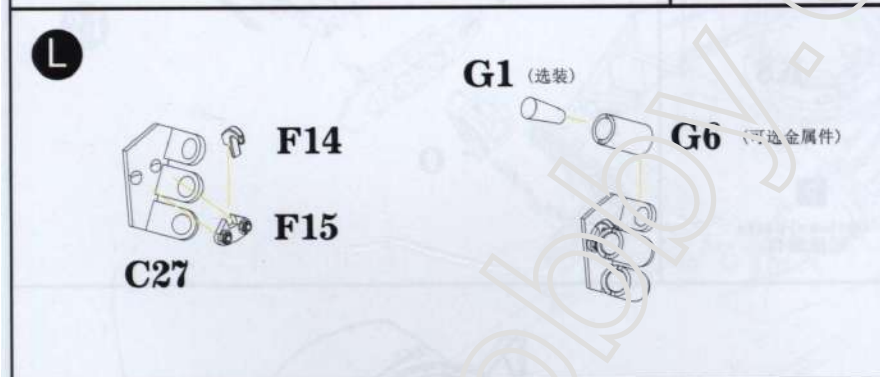
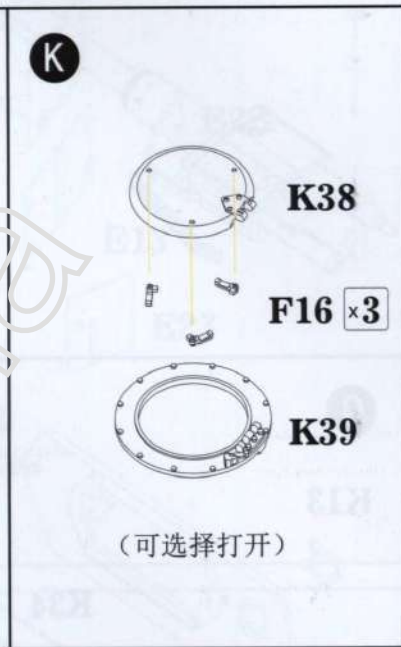
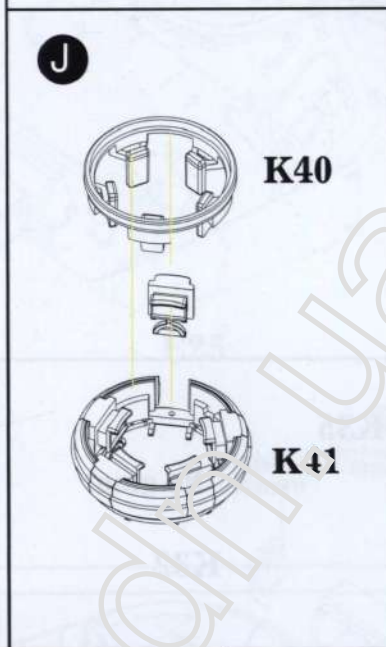
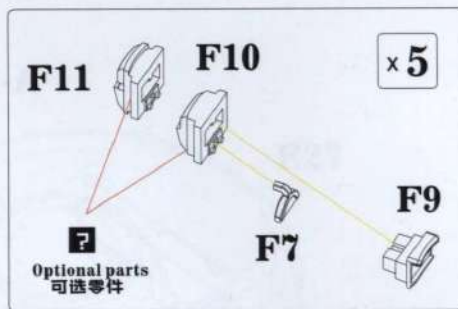
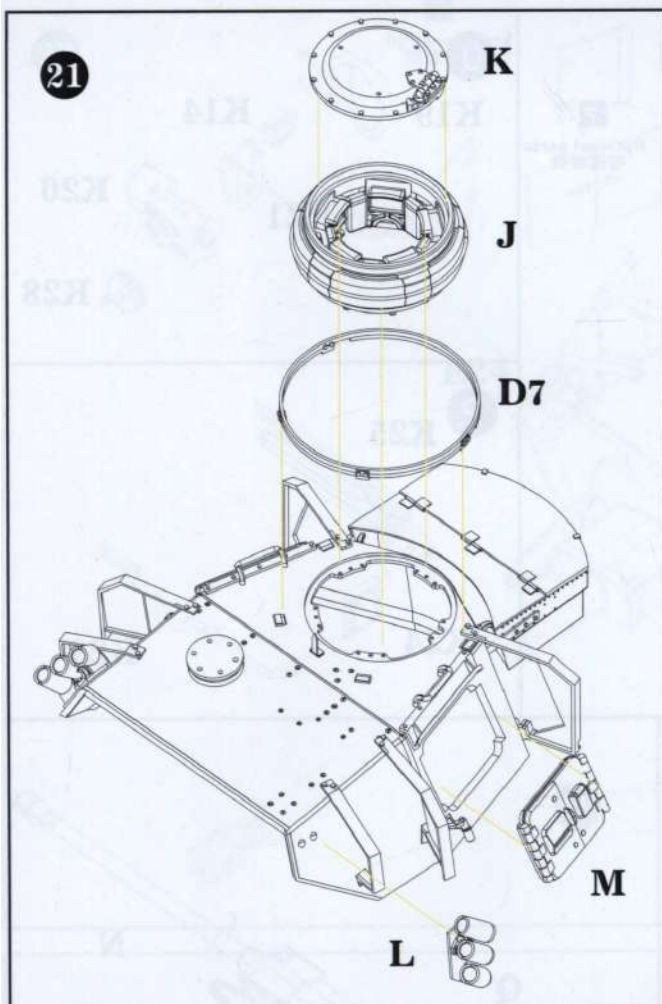



**N**

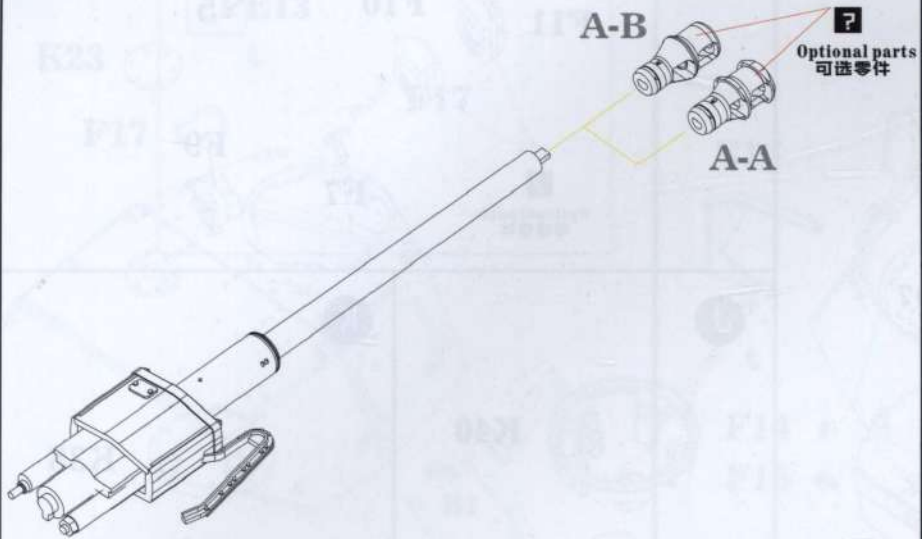

**O**

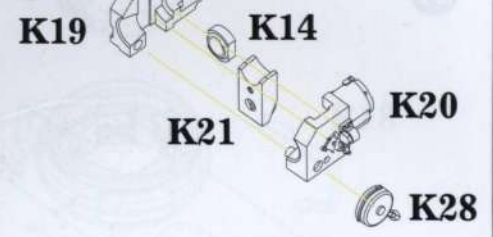

**P**

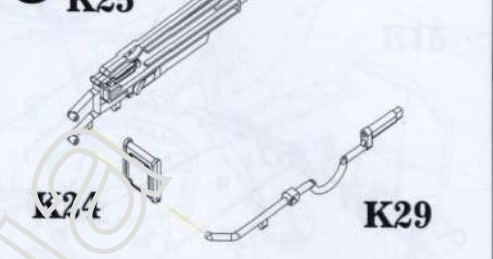

**Q**

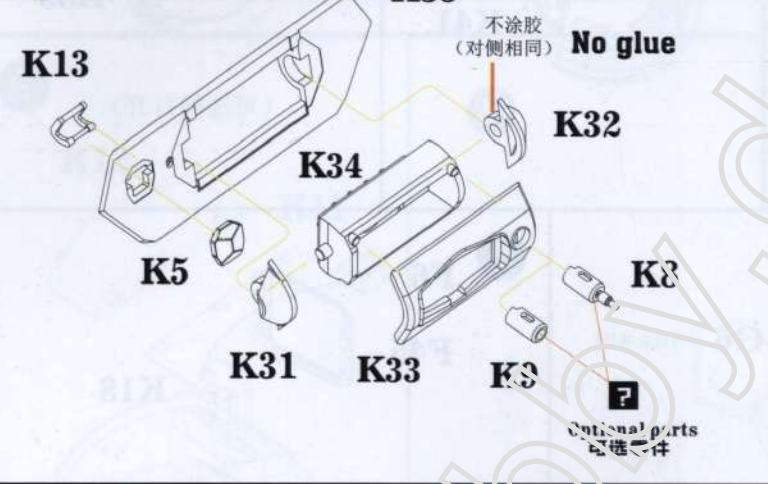

**22**

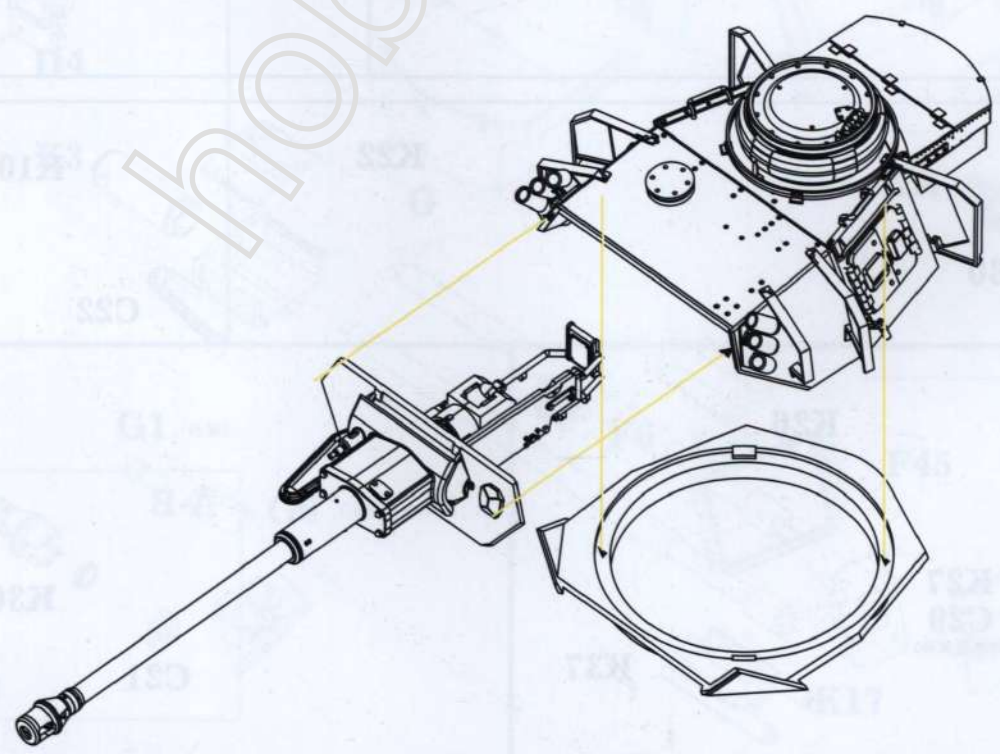
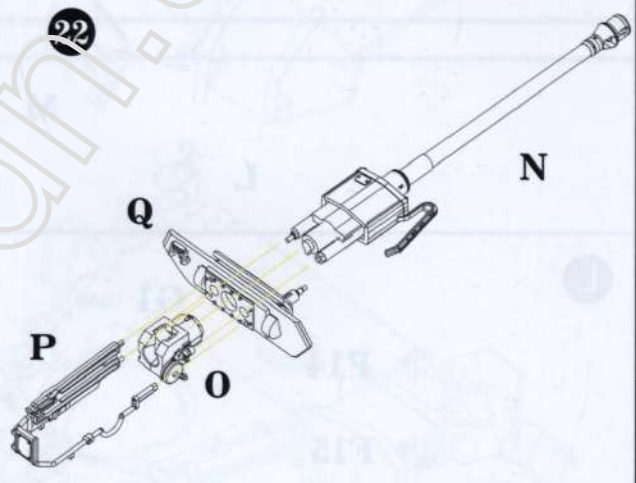



23

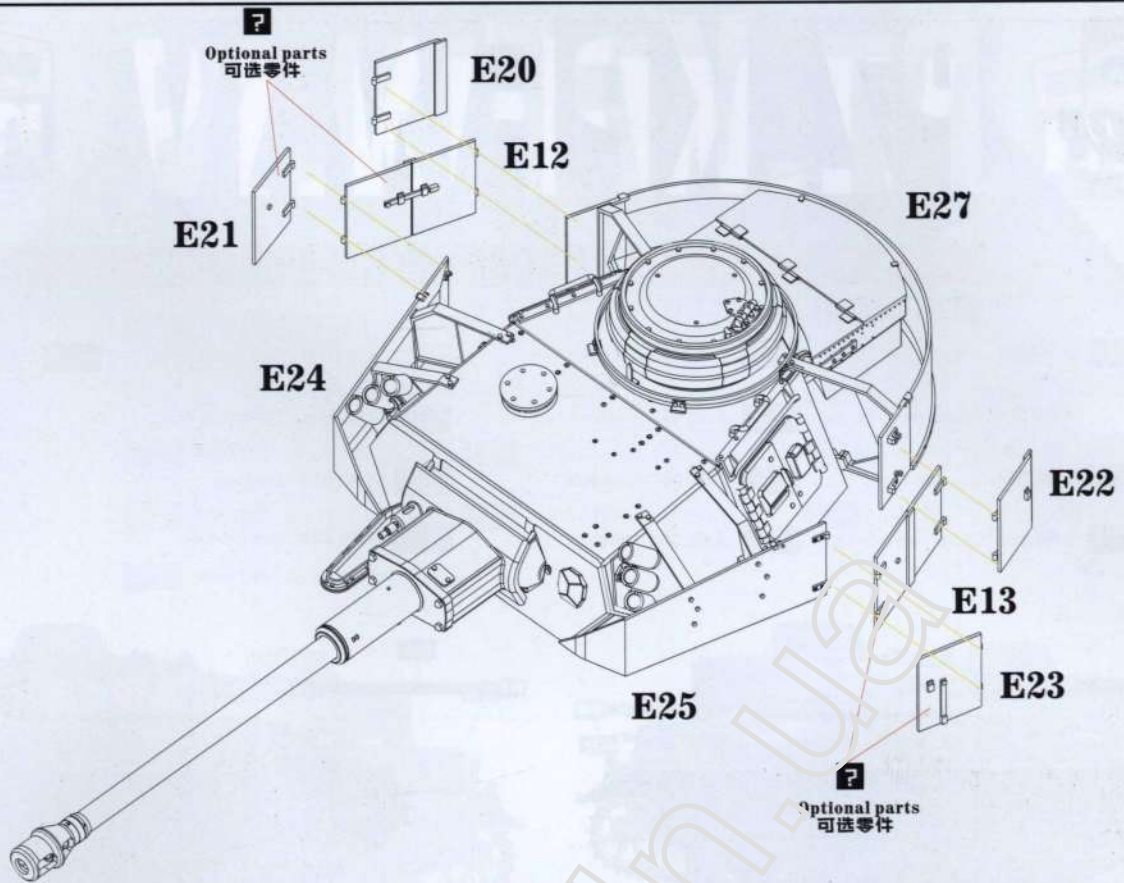

24

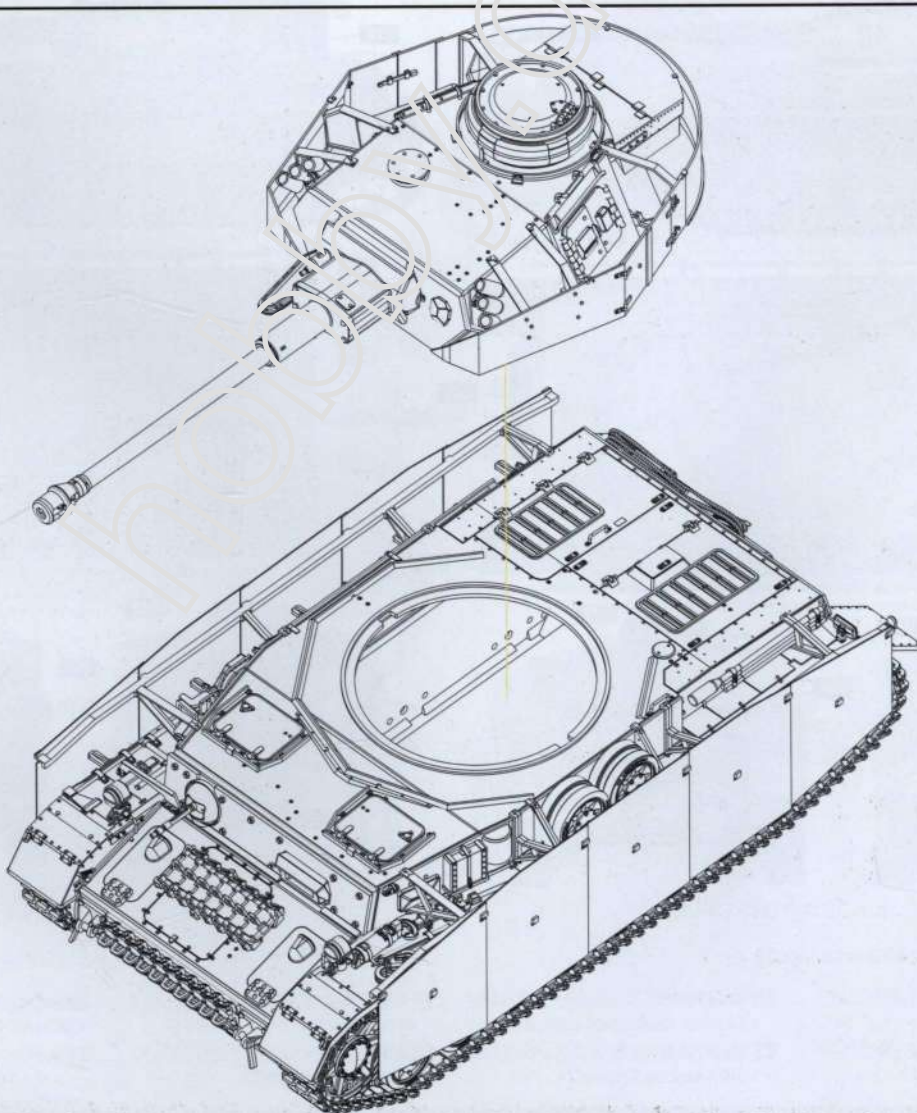



## PAINTING AND MARKING GUIDE

BORDER MODEL REF: BT-001

 A.MIG 001 Olivgrün Opt.1	 A.MIG 008 Dunkelgrau	 A.MIG 010 Dunkelgelb Mid War	 A.MIG 042 Old Rust
 A.MIG 024 Washable White Camo	 A.MIG 033 Rubber & Tires	 A.MIG 035 Dark Tracks	
 A.MIG 037 New Wood	 A.MIG 041 Dark Rust	 A.MIG 045 Gun Metal	
 A.MIG 096 Crystal Periscope Green	 A.MIG 002 Olivgrün Opt.2	 A.MIG 033 Rubber & Tires	

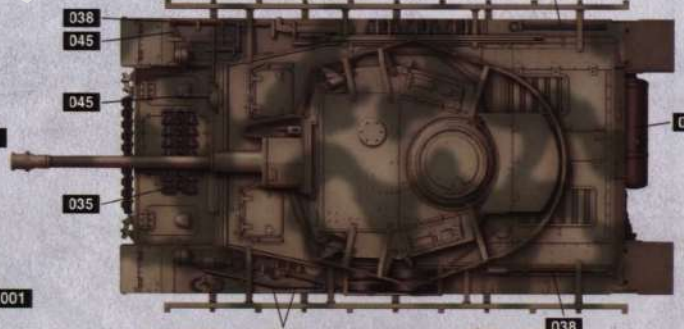
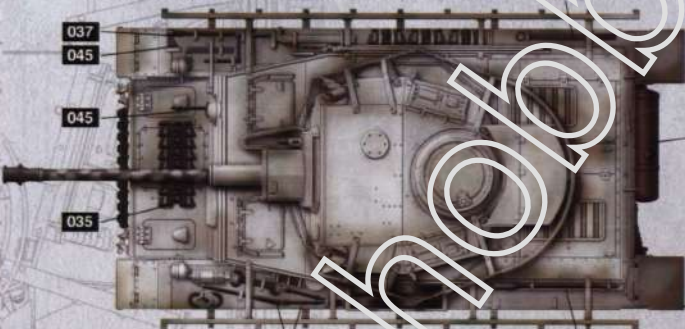
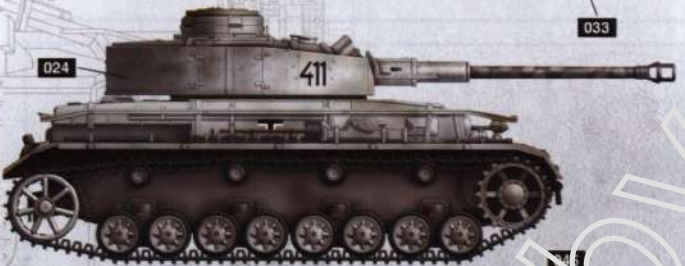

3rd Pz. Division. Eastern front 1943.

Unit unknown.











### WEATHERING STEPS WITH AMMO PRODUCTS

- |  |  |  |   |
|--|--|--|---|
| <b>1</b> GENERAL WASH<br>A.MIG-1010 Neutral Wash | <b>3</b> STREAKING<br>A.MIG-1255 Streakingbrusher Winter Grime | <b>5</b> RUST<br>A.MIG-3510 Rust         | <b>7</b> MUD & SPLASHES<br>A.MIG-1704 Heavy Earth A.MIG-1754 Damp Earth |
| <b>2</b> FILTER<br>A.MIG-1501 Grey for White     | <b>4</b> TRACK WASH<br>A.MIG-1002 Tracks Wash                  | <b>6</b> DUST<br>A.MIG-3004 Europe Earth | <b>8</b> DUST<br>A.MIG-1408 Fresh Engine Oil                            |



## PAINTING AND MARKING GUIDE

BORDER MODEL REF: BT-001

 A.MIG 001 Olivgrun Opt.1	 A.MIG 008 Dunkelgrau	 A.MIG 010 Dunkelgelb Mid War
 A.MIG 015 Schokobraun	 A.MIG 033 Rubber & Tires	 A.MIG 035 Dark Tracks
 A.MIG 036 Old Wood	 A.MIG 043 Shadow Rust	 A.MIG 045 Gun Metal
 A.MIG 096 Crystal Periscope Green		

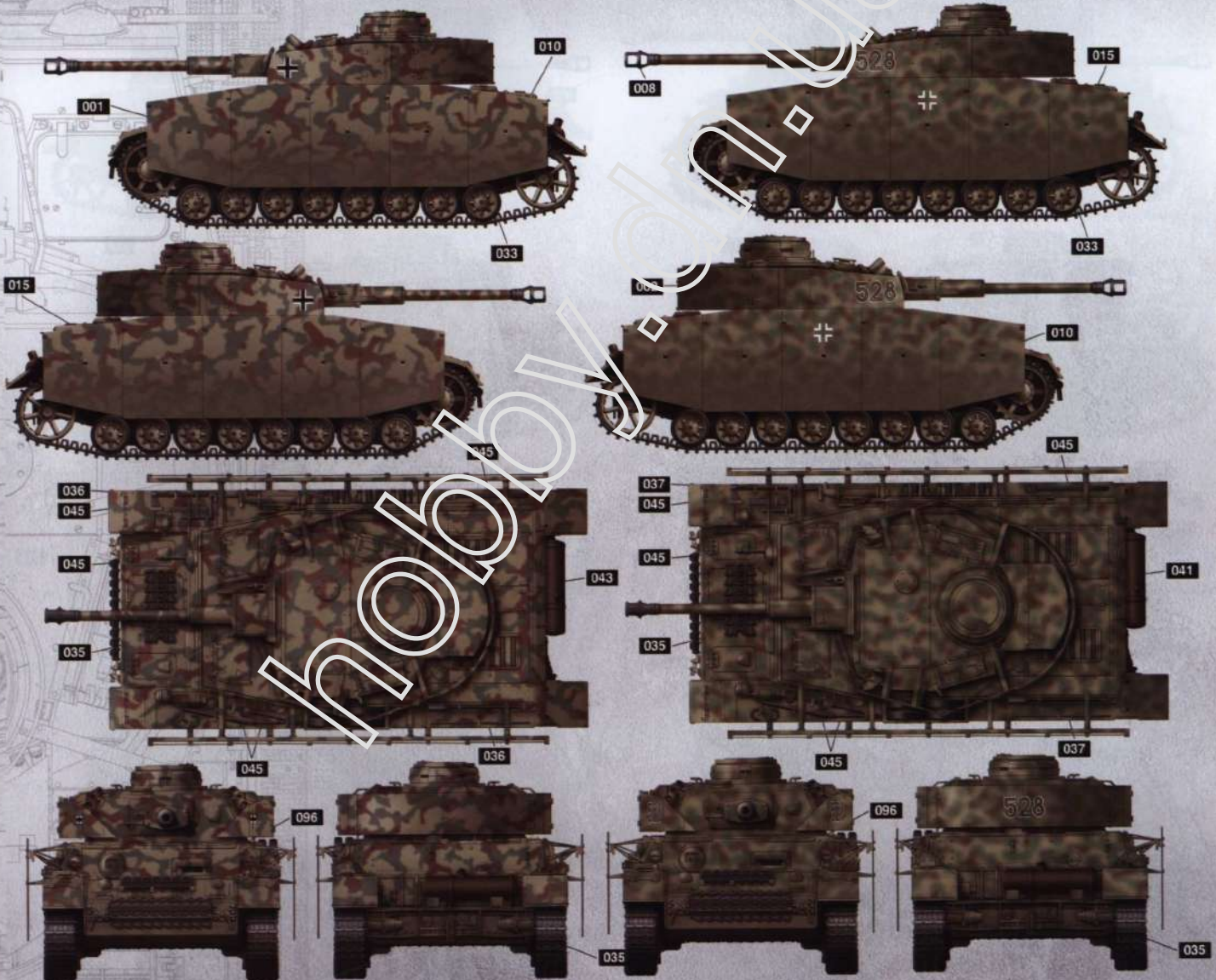

1st SS Leibstandarte "Adolf Hitler", Kharkov. March 1943.

Unit unknow. Eastern front.









**WEATHERING STEPS WITH AMMO PRODUCTS**

- |   |   |  |  |
|---|---|--|--|
| <b>1 GENERAL WASH</b><br>A.MIG-1008 Dark Wash     | <b>3 STREAKING</b><br>A.MIG-1252 Streakingbrusher Red Brown | <b>5 RUST</b><br>A.MIG-3510 Rust         | <b>7 MUD &amp; SPLASHES</b><br>A.MIG-1704 Heavy Earth A.MIG-1753 Turned Dirt |
| <b>2 FILTER</b><br>A.MIG-1510 Tan for 3 Tone Camo | <b>4 TRACK WASH</b><br>A.MIG-1002 Tracks Wash               | <b>6 DUST</b><br>A.MIG-3004 Europe Earth | <b>8 DUST</b><br>A.MIG-1408 Fresh Engine Oil                                 |



## PAINTING AND MARKING GUIDE

BORDER MODEL REF: BT-001

 A.MIG 008 Dunkelgrau	 A.MIG 010 Dunkelgelb Mid War	 A.MIG 024 Washable White Camo
 A.MIG 033 Rubber & Tires	 A.MIG 035 Dark Tracks	 A.MIG 036 Old Wood
 A.MIG 043 Shadow Rust	 A.MIG 045 Gun Metal	 A.MIG 096 Crystal Periscope Green

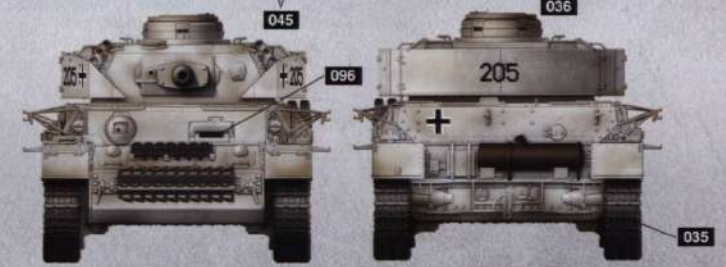
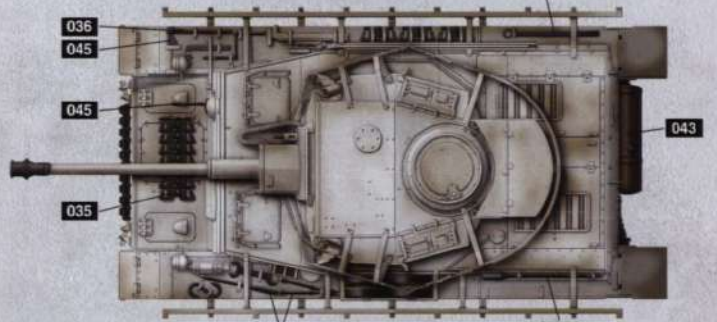
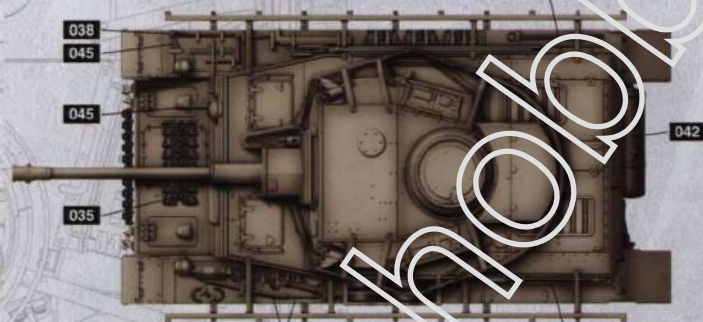

7th Pz. Regiment, 10th Pz. Division, DAK - Tunisia 1943.

1st SS Leibstandarte "Adolf Hitler". Kharkov, March 1943.

### WEATHERING STEPS WITH AMMO PRODUCTS

**1 GENERAL WASH**

A.MIG-1001 Afrika Korps Wash

**2 FILTER**

A.MIG-1504 Brown for Desert Yellow

**3 STREAKING**

A.MIG-1201 Streaking Grime for DAK

**4 TRACK WASH**

A.MIG-1002 Tracks Wash

**5 RUST**

A.MIG-3510 Rust

**6 DUST**

A.MIG-3003 North Africa Dust

**7 MUD & SPLASHES**

A.MIG-1700 Dry Light Soil A.MIG-1750 Dry Earth

**8 DUST**

A.MIG-1408 Fresh Engine Oil





# Pz.KPFW.IV



BORDER MODEL REF: BT-001

## Pz.Kpfw. IV Ausf. G LATE

Pz.Rgt.35, 4.Pz.Div., No.420  
Summer 1943 Eastern Front, North Kursk

### 4号G 后期生产型

第4装甲师 35装甲团 420号  
1943年夏 东线 库尔斯克北部

CV004

CV005

CV006

## 4号G 后期生产型

第20装甲师 21装甲营 301号  
1943年春 东线 奥廖尔地区

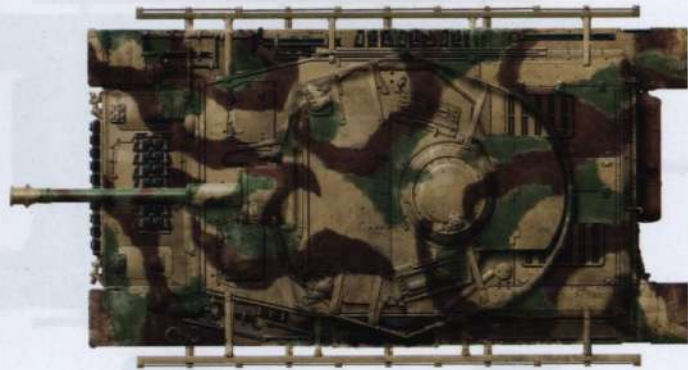





# Pz.KPFW.IV



TRANSFORM  
易模型

BORDER MODEL REF: BT-001

## Pz.Kpfw. IV Ausf. G LATE

Pz.regiment, Hermann Göring Div., No.432  
Spring 1943 Italy

### 4号G 后期生产型

赫尔曼戈林师 装甲团 432号  
1943年春 意大利

CV004

CU007

CV018

### 4号G 后期生产型

第2装甲师 第3装甲团 632号  
1943年夏 东线 库尔斯克北部

