

Clear Prop!

STARTER



H-75N HAWK

1:72

model # CP72022



scale model kit

SPAN: 157.9 mm



LENGTH: 121.7 mm



NUMBER OF PARTS: 77 pcs

- 1** stages of assembly
- ?** optional
- A** variants of assembly
- glue by super glue
- A1** part number
- do not glue
- 1** separate details
- make a hole
- apply decals
- detach with knife
- 1** apply the adhesive mask
- paint
- bend
- repeat the operation N times

Role	Fighter
Manufacturer	Curtiss-Wright Corporation
First flight	6 May 1935
Primary users	United States Army Air Corps, Finnish Air Force, French Air Force, Royal Air Force
Number built	215 (Model 75) plus 900 export Hawk 75 variants

Curtiss Hawk Model 75, is an American-designed and built fighter aircraft of the 1930s and 40s. A contemporary of both the Hawker Hurricane and Messerschmitt Bf 109, it was one of the first of a new generation of combat aircraft—a sleek monoplane design making extensive use of metal in its construction and powered by a powerful radial engine.

The Curtiss Model 75 was a private venture by the company, designed by former Northrop Aircraft Company engineer Don R. Berlin. The first prototype, constructed in 1934, featured all-metal construction with fabric-covered control surfaces, a Wright XR-1670-5 radial engine developing 900 hp (670 kW), and typical United States Army Air Corps armament of one .30 in (7.62 mm) and one .50 in (12.7 mm) machine gun firing through the propeller arc. Also typical of the time was the total absence of cockpit armor or self-sealing fuel tanks. The prototype first flew on 6 May 1935, reaching 281 mph (452 km/h) at 10,000 ft (3,000 m) during early test flights. On 27 May 1935, the prototype was flown to Wright Field, Ohio, to compete in the USAAC fly-off for a new single-seat fighter, but the contest was delayed because the Seversky entry crashed on its way there. Curtiss took advantage of the delay to replace the unreliable engine with a Wright XR-1820-39 Cyclone producing 950 hp (710 kW) and to rework the fuselage, adding the distinctive scalloped rear windows to improve visibility. The new prototype was designated Model 75B with the R-1670 version retroactively designated Model 75D.

REQUIRED PAINTS

- | | | | | | | | |
|---|---|---|--|---|--|--|---|
| A MR. COLOR 90
A.MIG-8215
SHINE SILVER | B MR. COLOR 302
A.MIG-0238
GREEN | C MR. COLOR 8
A.MIG-0195
SILVER | D MR. COLOR 1
A.MIG-0047
WHITE | E MR. COLOR 33
A.MIG-0046
BLACK | F MR. COLOR 44
A.MIG-0013
TAN | G MR. COLOR 303
A.MIG-0065
GREEN | H MR. COLOR 27
A.MIG-0220
INTERIOR GREEN |
| I MR. COLOR 28
A.MIG-0191
STEEL | J MR. COLOR 13
A.MIG-0239
NEUTRAL GREY | K MR. COLOR 61
A.MIG-0187
BURNT IRON | L MR. COLOR 137
A.MIG-0033
TIRE BLACK | M MR. COLOR 352
A.MIG-0221
INTERIOR YELLOW | N MR. COLOR 3
A.MIG-0049
RED | O MR. COLOR 417
A.MIG-0063
LIGHT BLUE | |



THIS MODEL IS PRODUCED FOR EXPERIENCED MODELERS OVER 14 YEARS

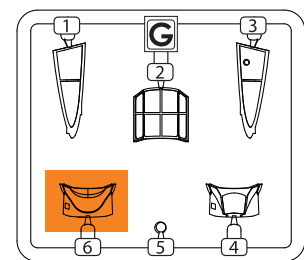
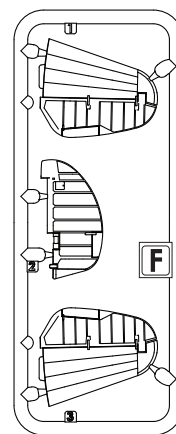
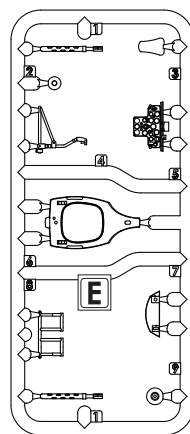
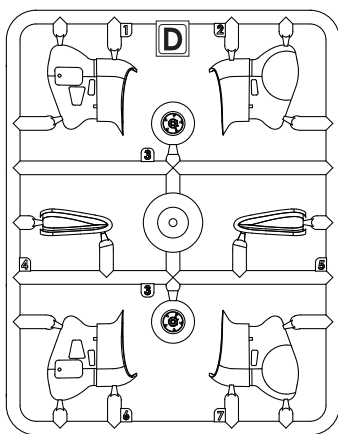
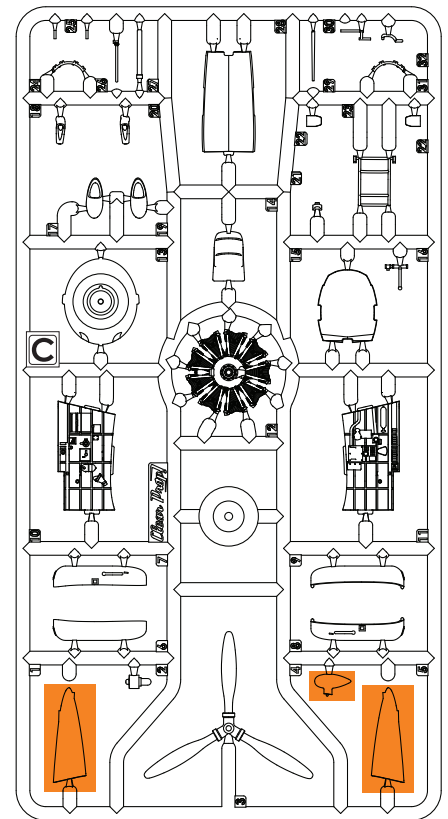
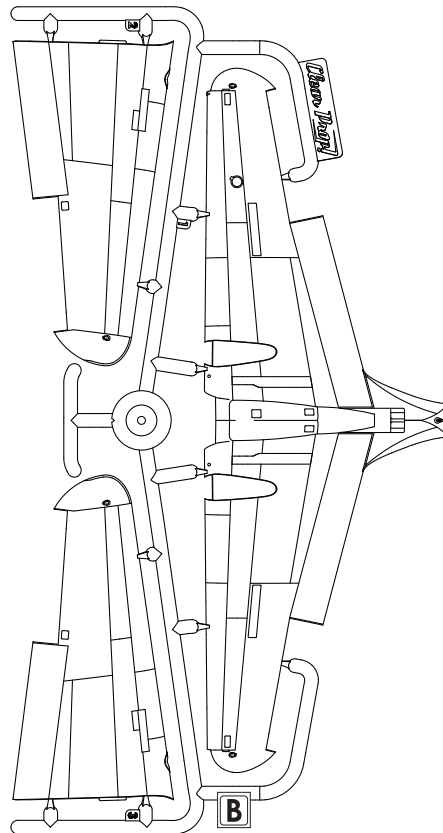
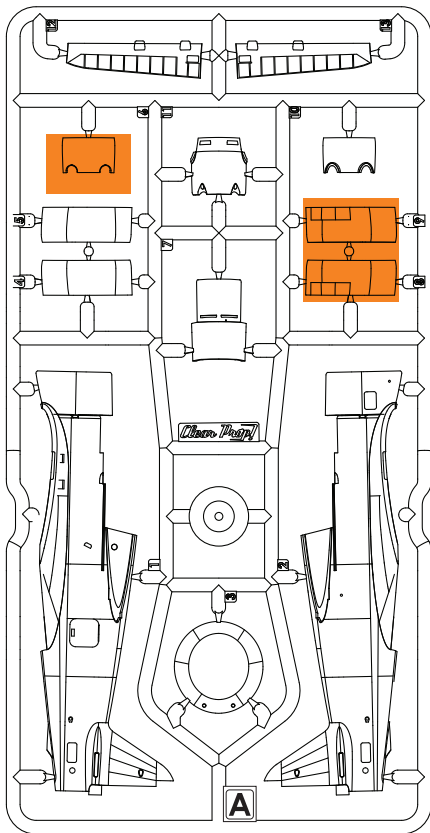

DECAL SHEET



Parts not for use

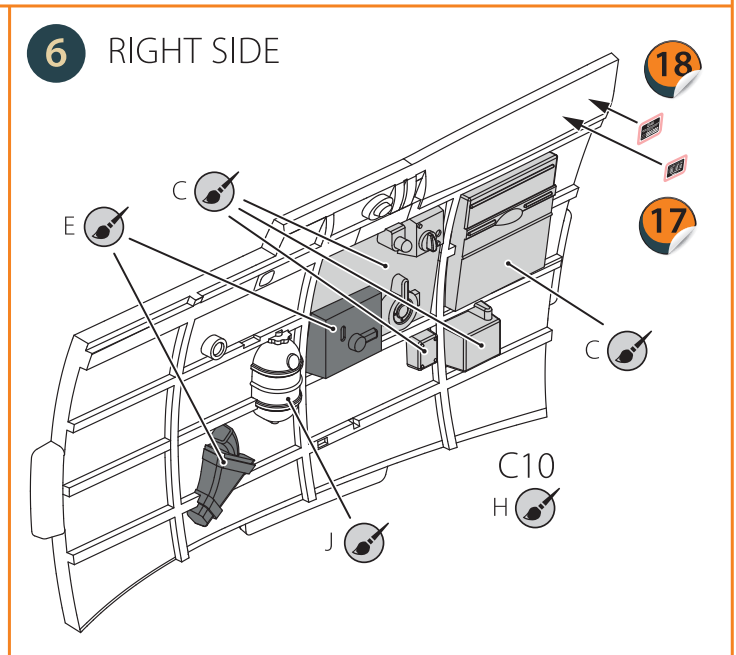
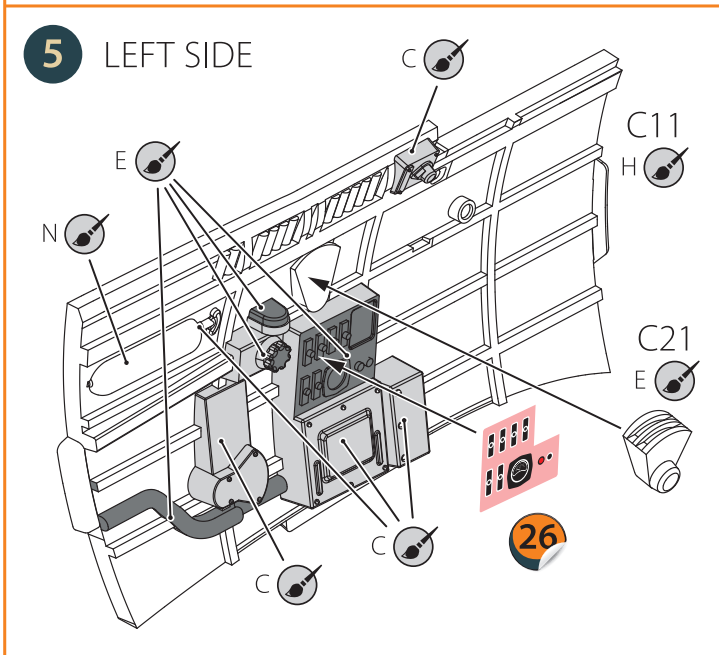
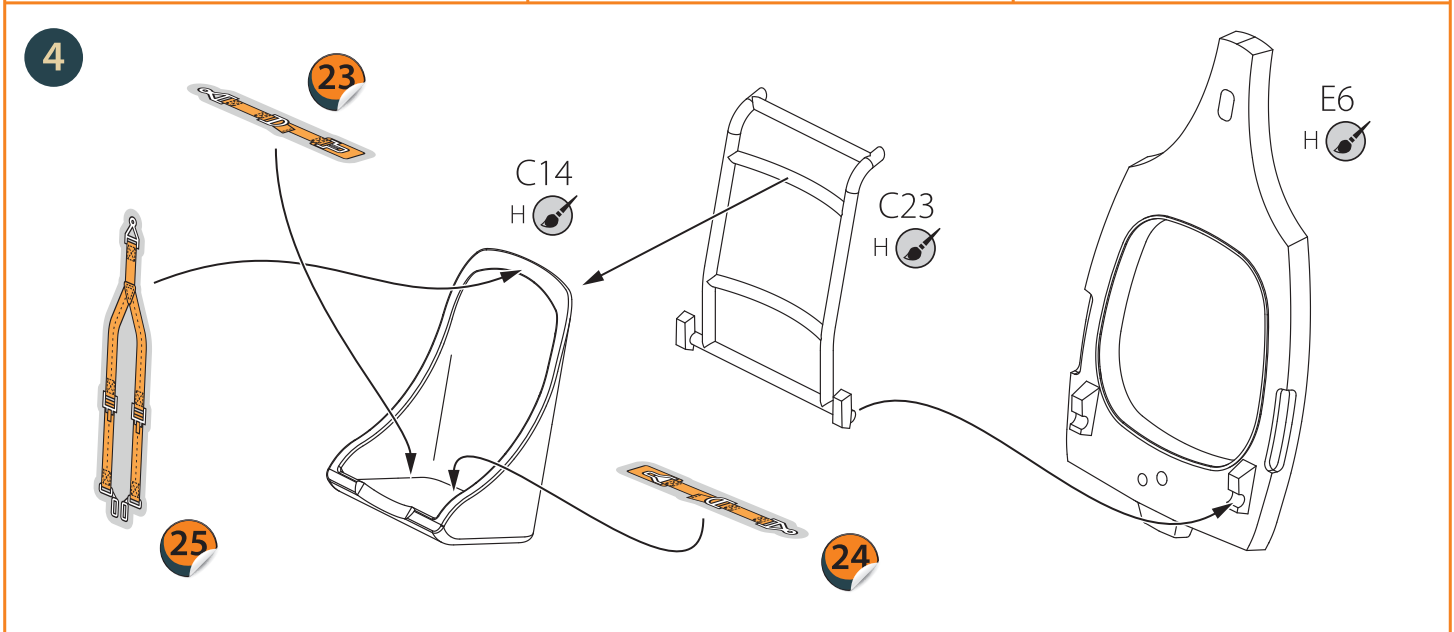
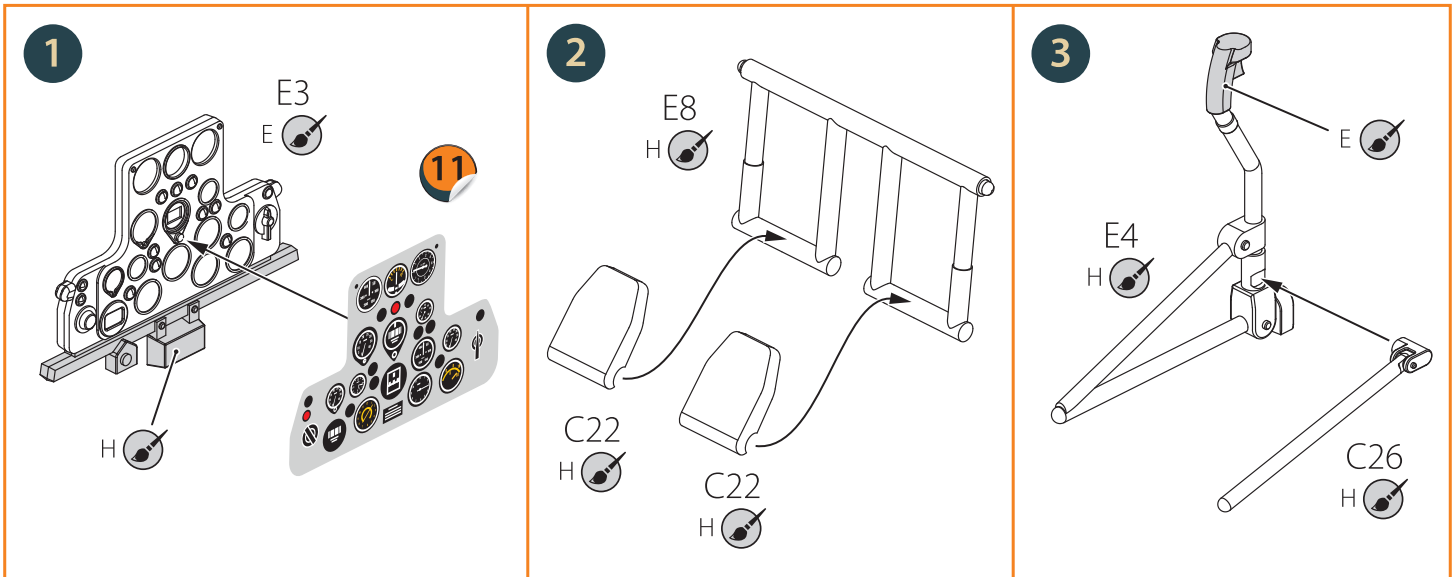

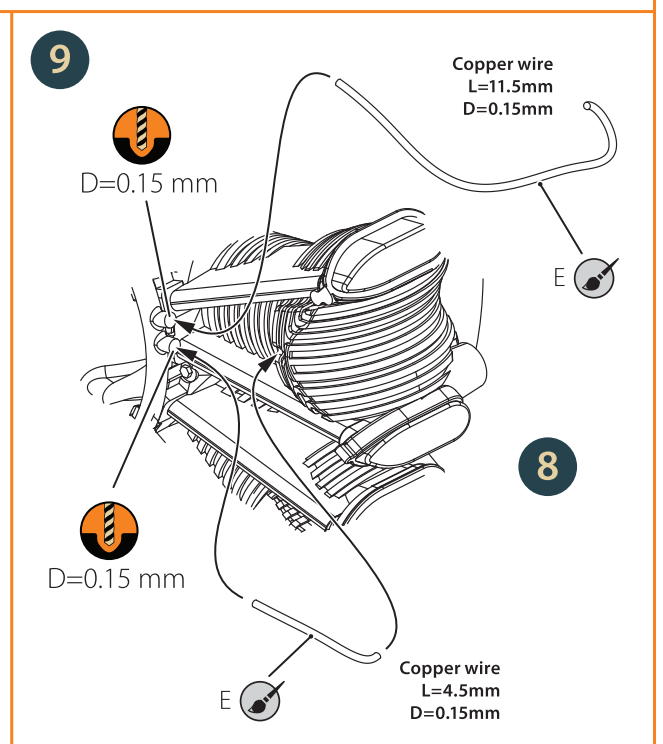
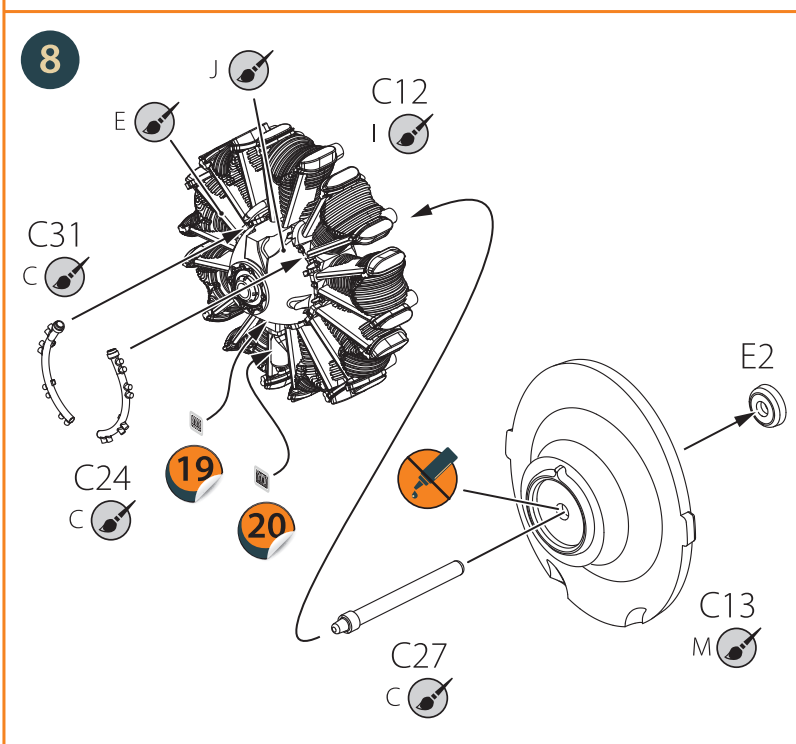
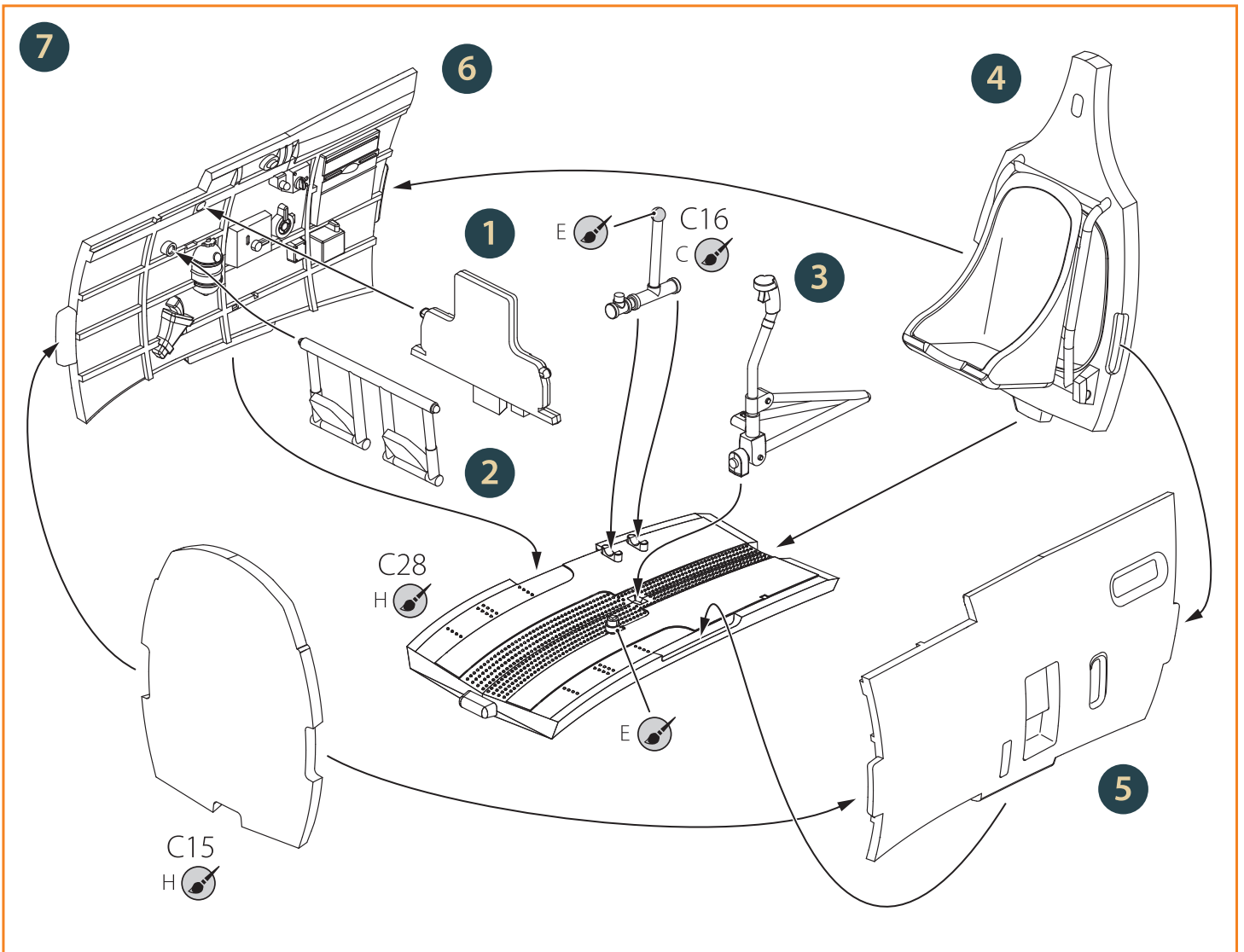

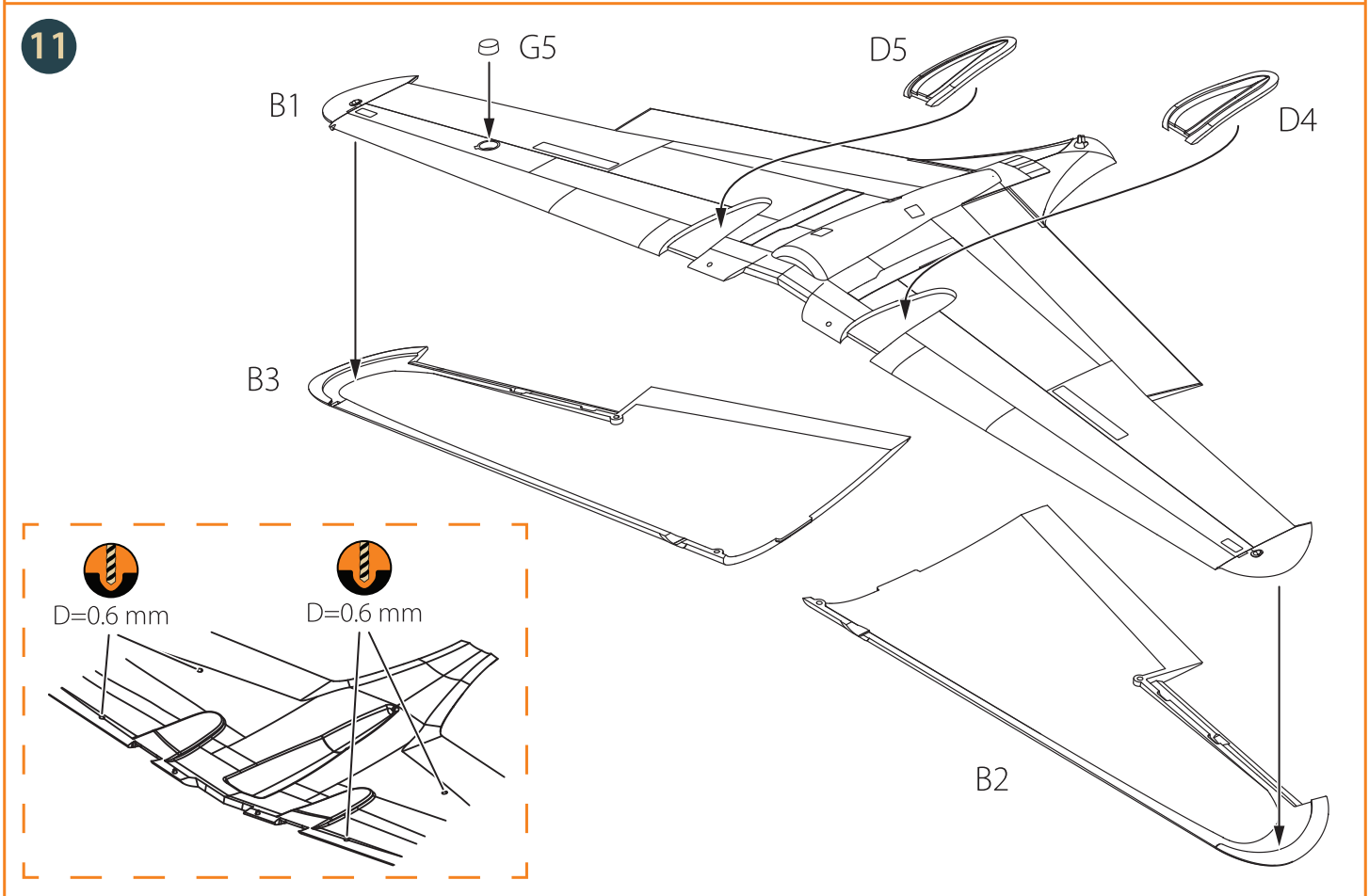
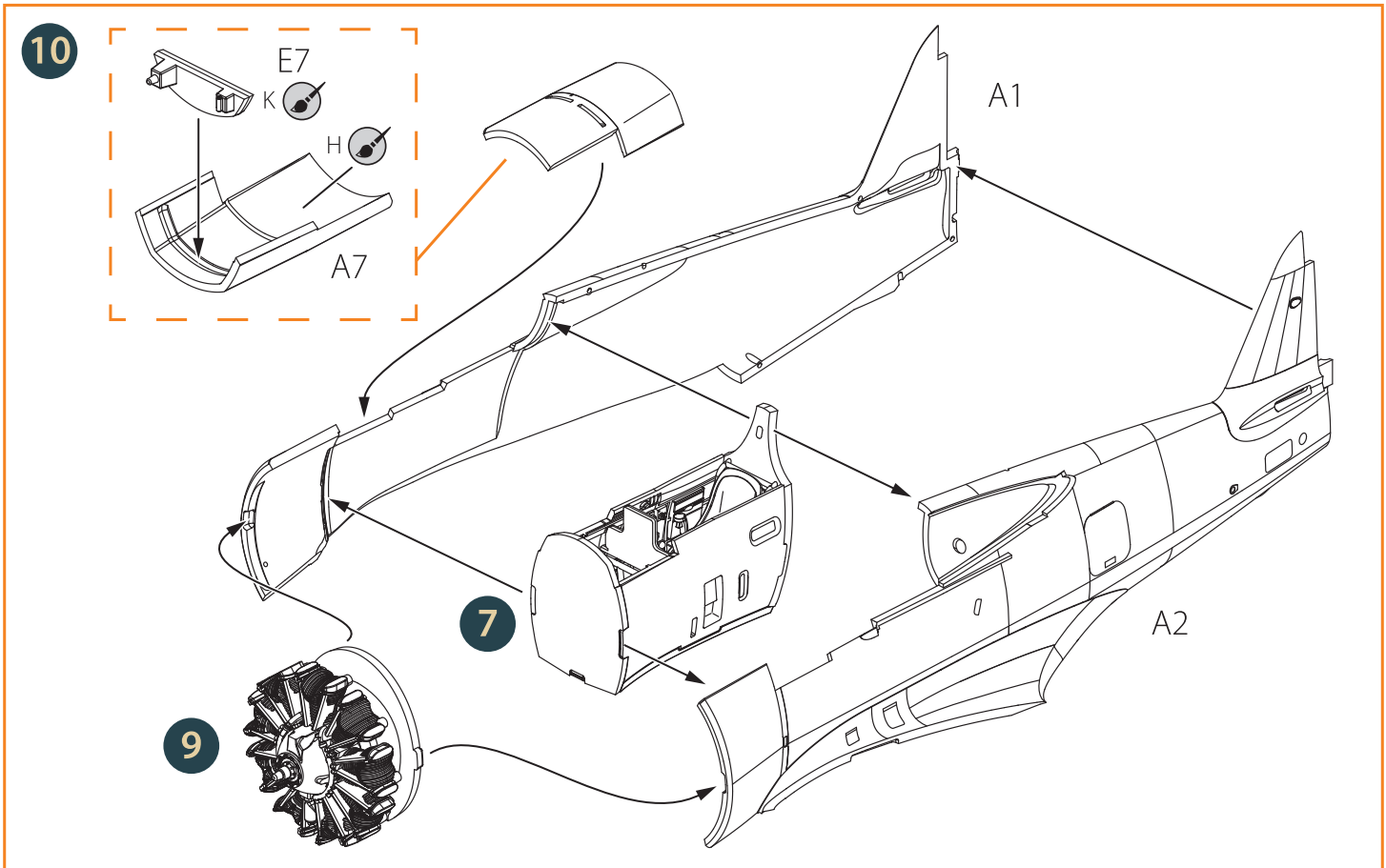

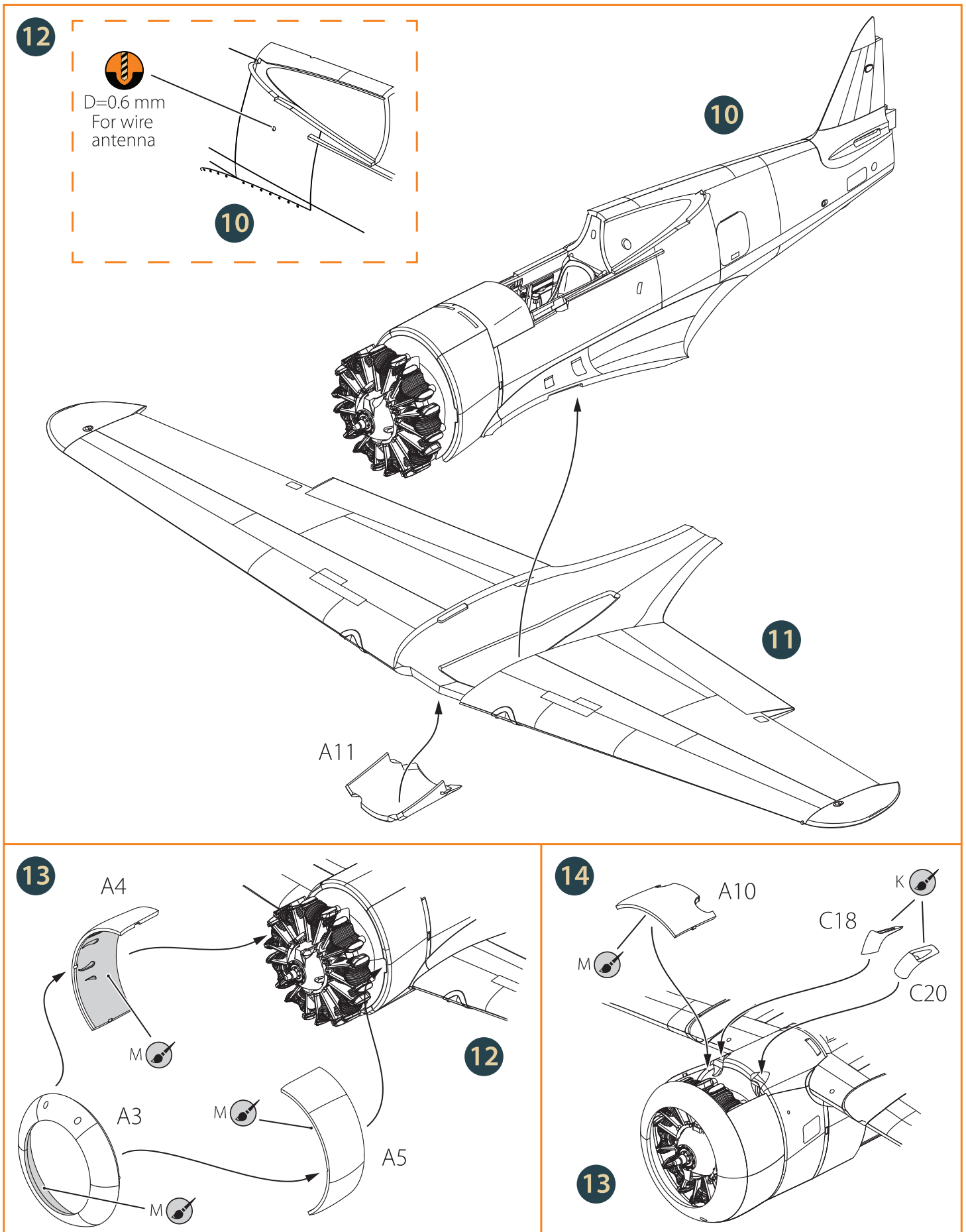

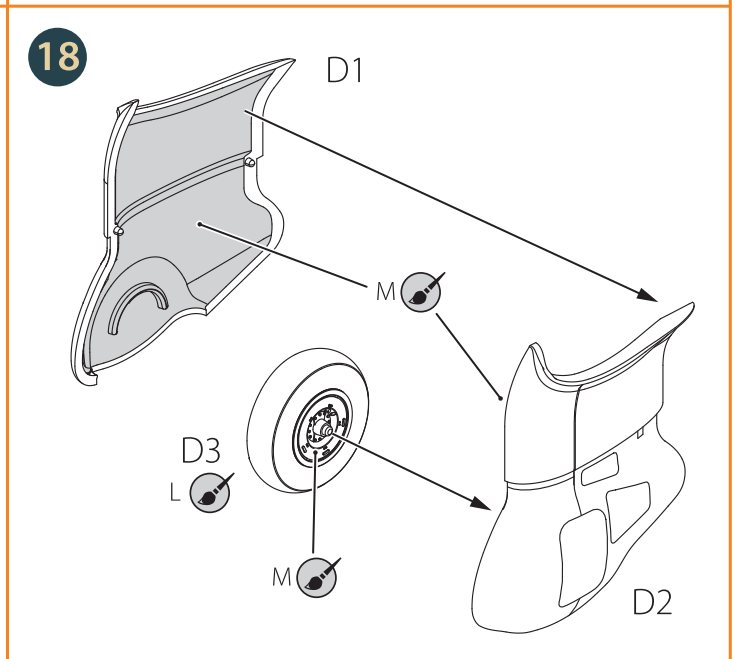
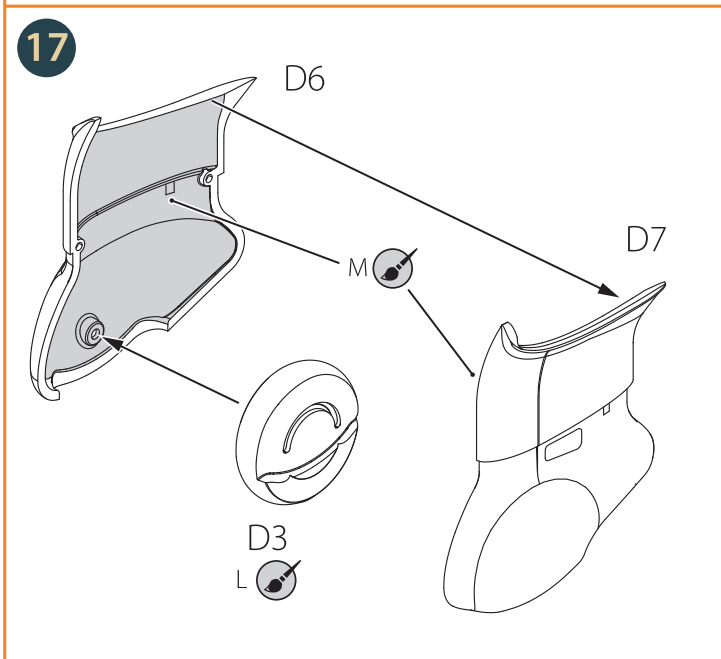
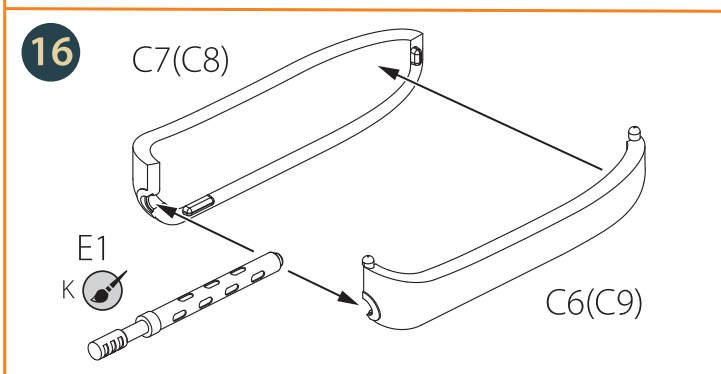
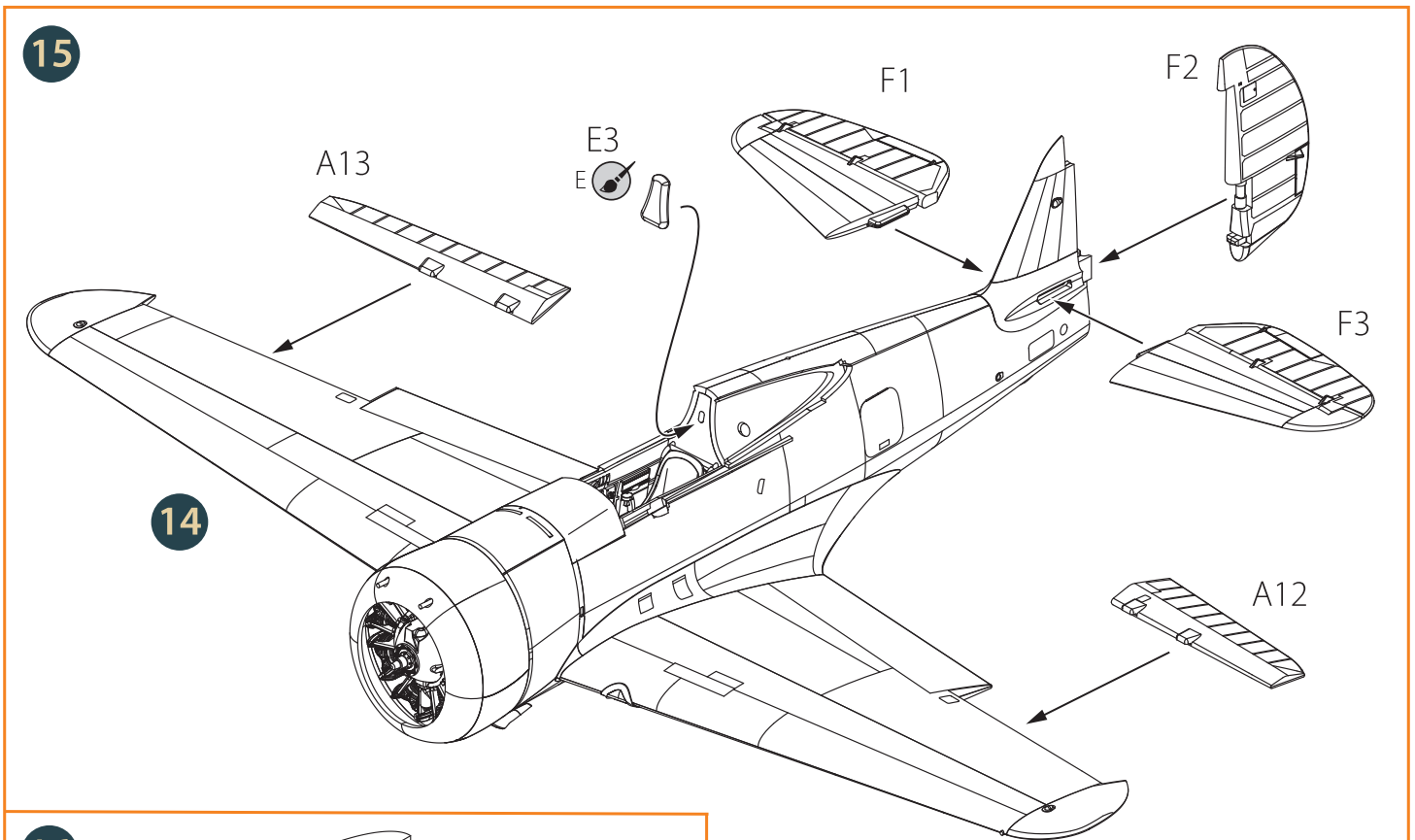

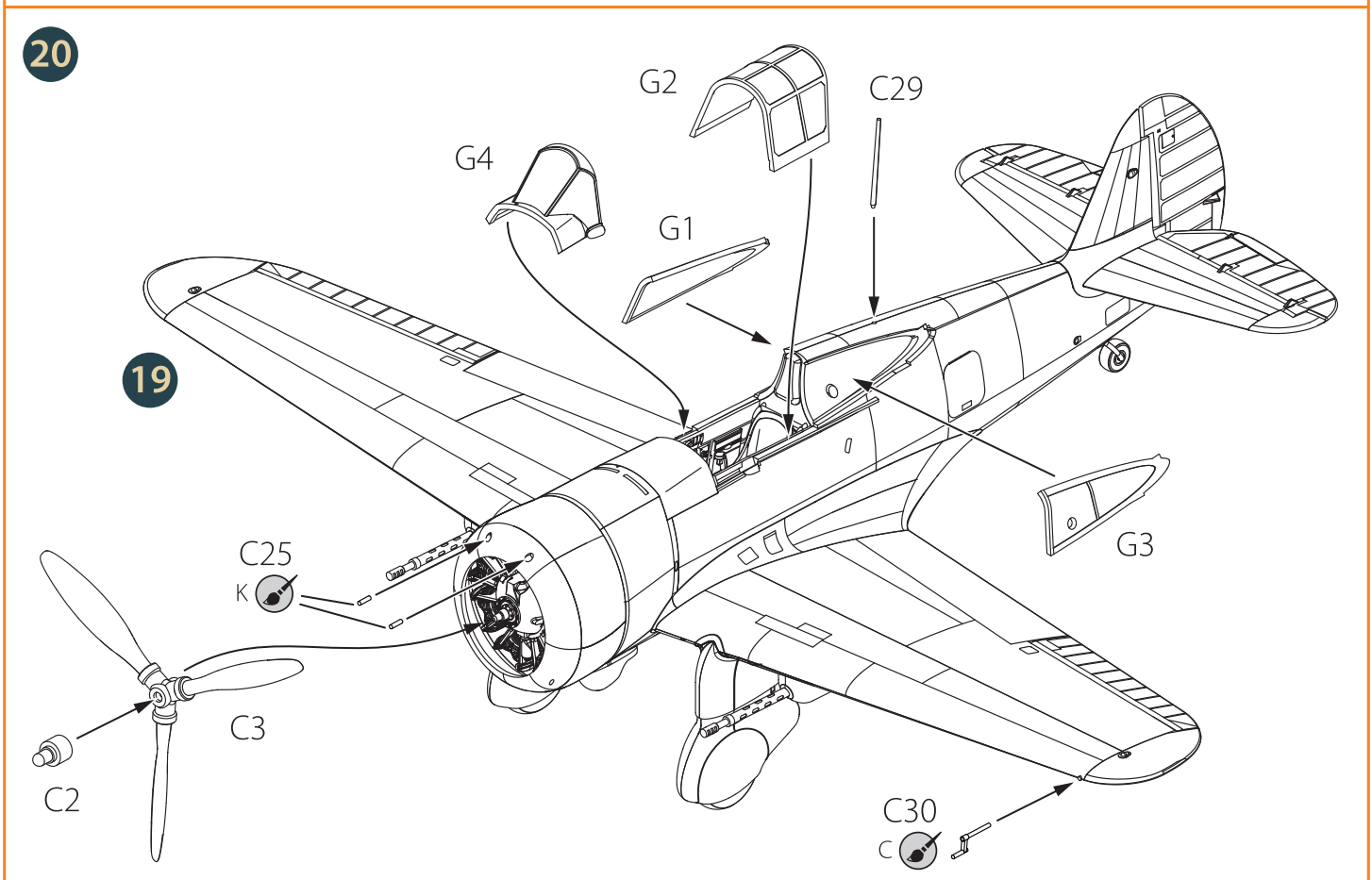
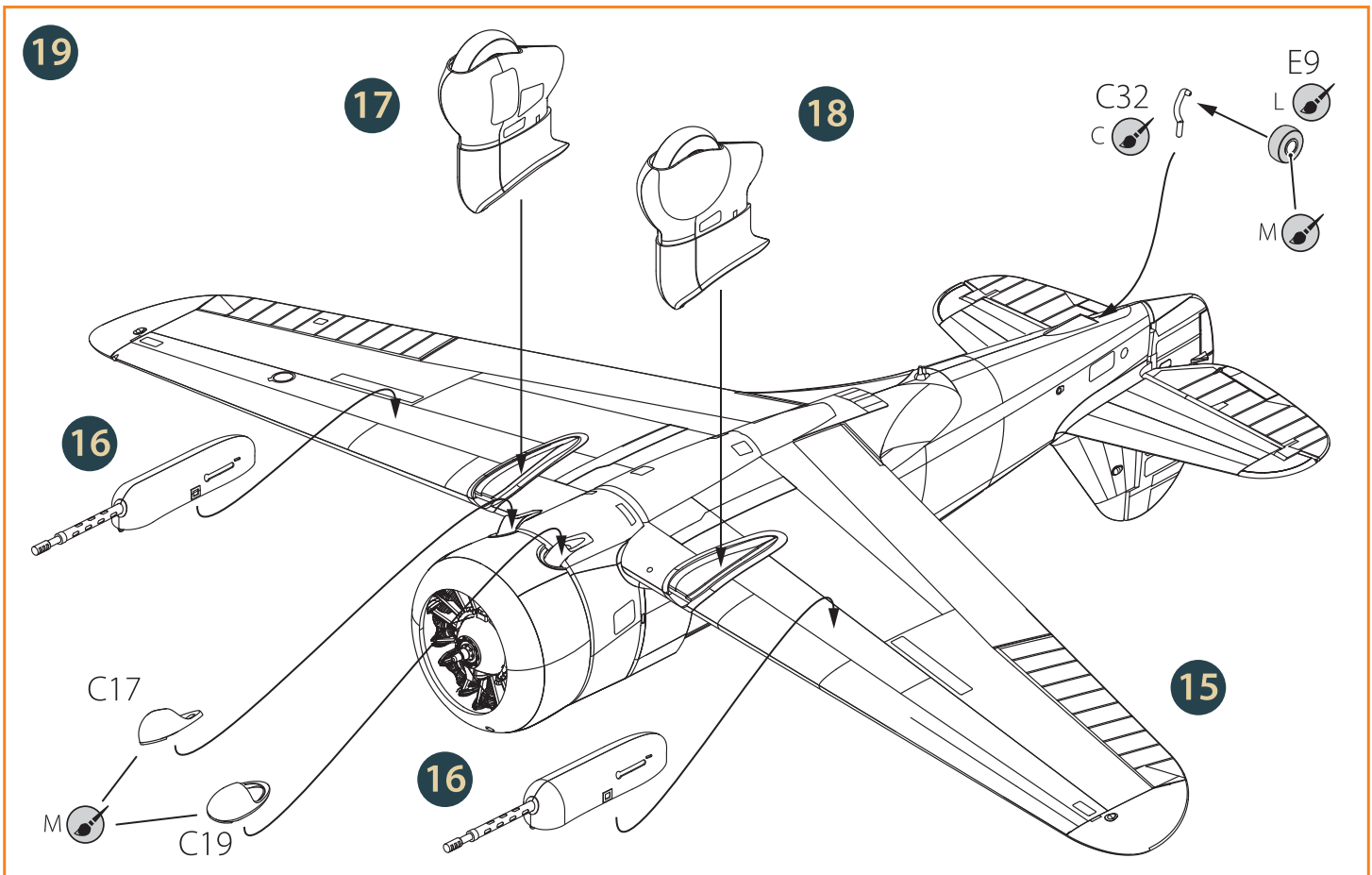



A
MR. COLOR 90
A.MIG-8215
SHINE SILVER



B
MR. COLOR 526
A.MIG-0079
BROWN



D
MR. COLOR 1
A.MIG-0047
WHITE



E
MR. COLOR 33
A.MIG-0046
BLACK



F
MR. COLOR 44
A.MIG-0013
TAN



G
MR. COLOR 303
A.MIG-0065
GREEN



N
MR. COLOR 3
A.MIG-0049
RED



O
MR. COLOR 308
A.MIG-0203
LIGHT GHOST GREY

① Curtiss Hawk H-75N, 60 Squadron, 66th Wing Nakhon Phanom, Thailand 1940

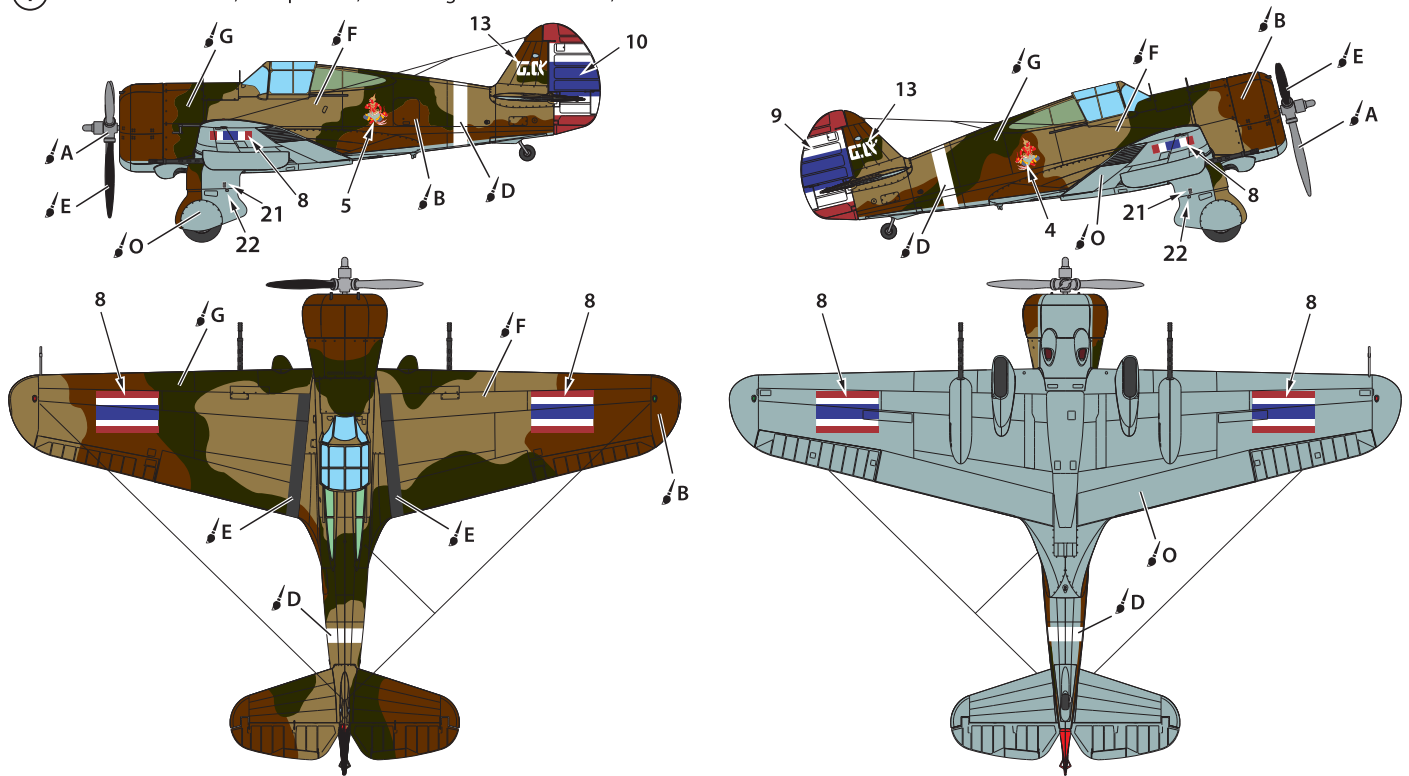

② Curtiss Hawk H-75N, 5-th Air Wing RTAF

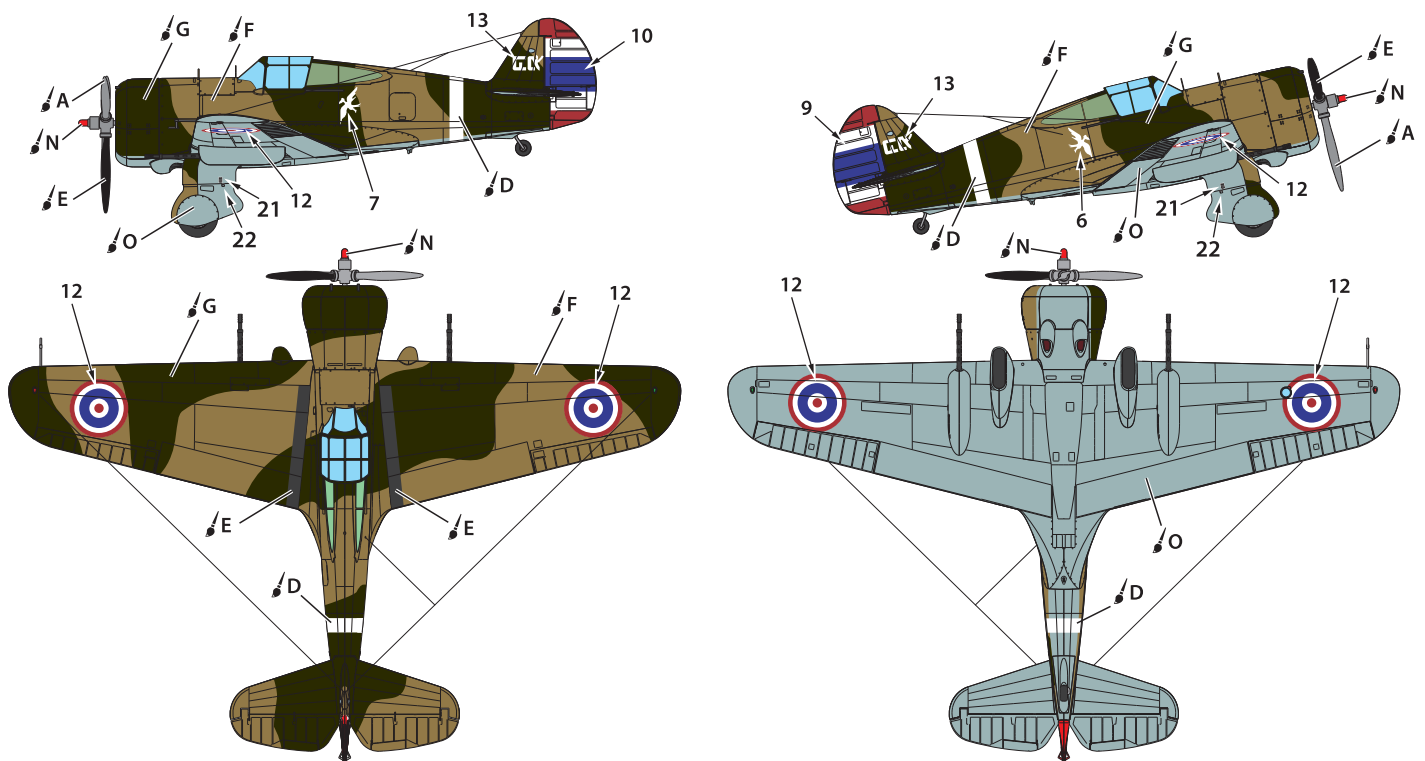



A
MR. COLOR 90
A.MIG-8215
SHINE SILVER



B
MR. COLOR 526
A.MIG-0079
BROWN



D
MR. COLOR 1
A.MIG-0047
WHITE



E
MR. COLOR 33
A.MIG-0046
BLACK



F
MR. COLOR 44
A.MIG-0013
TAN



G
MR. COLOR 303
A.MIG-0065
GREEN



N
MR. COLOR 3
A.MIG-0049
RED



O
MR. COLOR 308
A.MIG-0203
LIGHT GHOST GREY

③ Curtiss Hawk H-75N, 16 Squadron, Lampang, Thailand, 1944

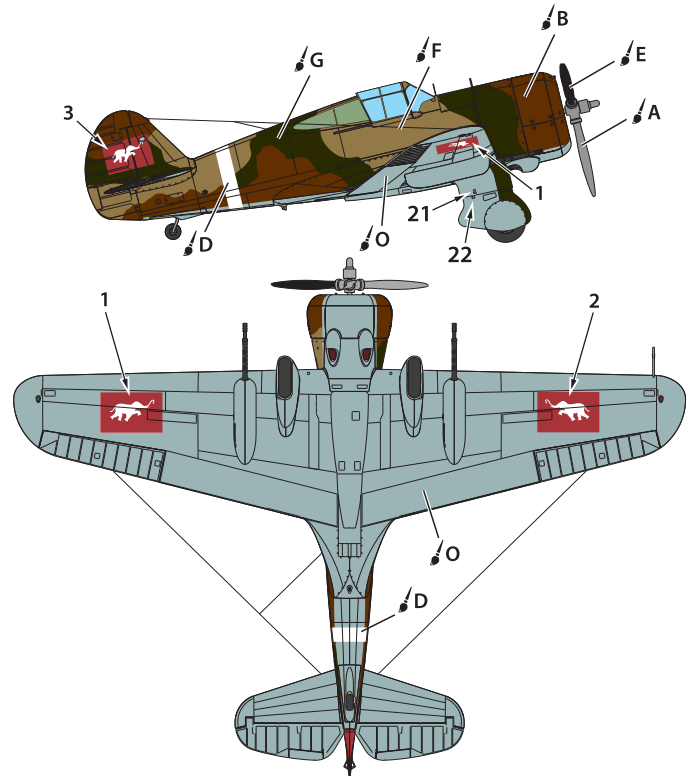
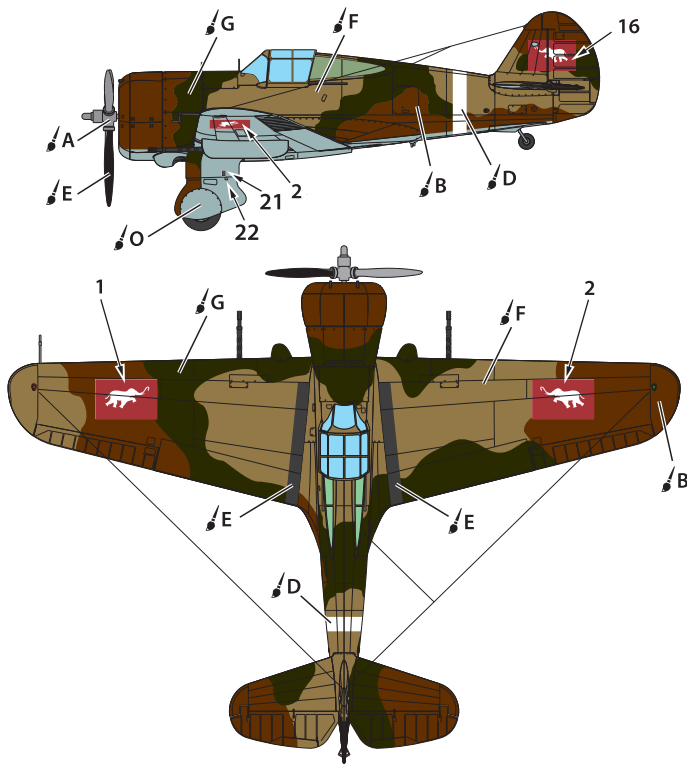

④ Curtiss Hawk H-75N, unknown unit, RTAF, 1941

