



STARTER



I-16 TYPE 5

1938-1941

1:72

model # CP72025



scale model kit

SPAN: 125,2 mm



LENGTH: 84,5 mm



NUMBER OF PARTS: 102 pcs

- stages of assembly
- variants of assembly
- part number
- fill with putty
- apply decals
- apply the adhesive mask
- bend
- optional
- glue by super glue
- do not glue
- make a hole
- detach with knife
- paint
- repeat the operation N times

Role	Fighter
National origin	Soviet Union
Manufacturer	USSR, Plant No. 21, Plant No. 39, Plant No. 153, Plant No. 458
First flight	30 December 1933 (TsKB-12)
Primary users	Soviet Air Force, Spanish Republican Air Force, Chinese Nationalist Air Force
Produced	November 1934 – 1942
Number built	10,292 (6,848 fighters and 3,444 trainers)

I-16 (TsKB-12) - a Soviet single-engine monoplane fighter of the 1930s, created at the Central Design Bureau by a team led by aircraft designer Nikolai Polikarpov. One of the world's first mass-produced monoplane fighters with retractable landing gear in flight. The aircraft had a mixed design. The serial production of the aircraft, originally with the M-22 engine, started in 1934, and really unfolded only the next year. In 1935, it became possible to install M-25 engines on the aircraft, which were a Soviet copy of the American Wright-Cyclone F-3. The production of these engines was launched at the newly built aircraft factory No.19 in Perm. In 1935, using often American parts, the plant produced 660 M-25 engines. Some of these engines were intended for the I-16. In general, this aircraft was very reminiscent of the third prototype with the Wright-Cyclone F-3. However, the engine cowling has changed somewhat and received frontal blinds, which have become a characteristic feature of this aircraft. At production plant No.21 in Gorky, the aircraft received the designation type 5 and became the most massive single-seat modification of the I-16. Until the end of 1937, more than 2,500 planes were built. I-16 type 5 fought in Spain, China, were widely used at the initial stage of the Second World War

REQUIRED PAINTS

- | | | | | | | | | |
|--------------------------------|-----------------------------|--------------------------------|--------------------------|-------------------------|------------------------------|-------------------------|--------------------------|------------------------|
| A.MIG-0080
AMT-4 GREEN | B.MIG-0046
AMT-6 BLACK | C.MIG-0251
AMT-7 LIGHT BLUE | D.MIG-0046
BLACK | E.MIG-0194
ALUMINIUM | F.MIG-0191
POLISHED STEEL | G.MIG-0195
SILVER | H.MIG-0033
TIRE BLACK | I.MIG-0202
DECK TAN |
| J.MIG-0187
PALE BURNT METAL | K.MIG-0125
ORANGE YELLOW | L.MIG-0049
INSIGNIA RED | M.MIG-0205
STEEL GRAY | N.MIG-0050
WHITE | O.MIG-257
AZURE BLUE | P.MIG-249
LIGHT BLUE | | |



THIS MODEL IS PRODUCED FOR EXPERIENCED MODELERS OVER 14 YEARS

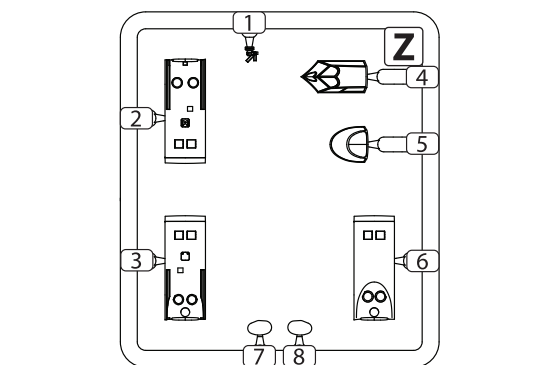
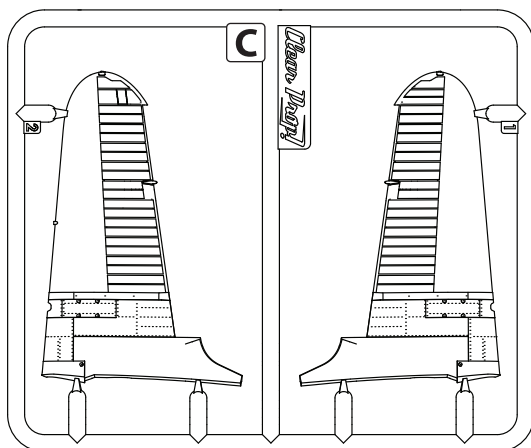
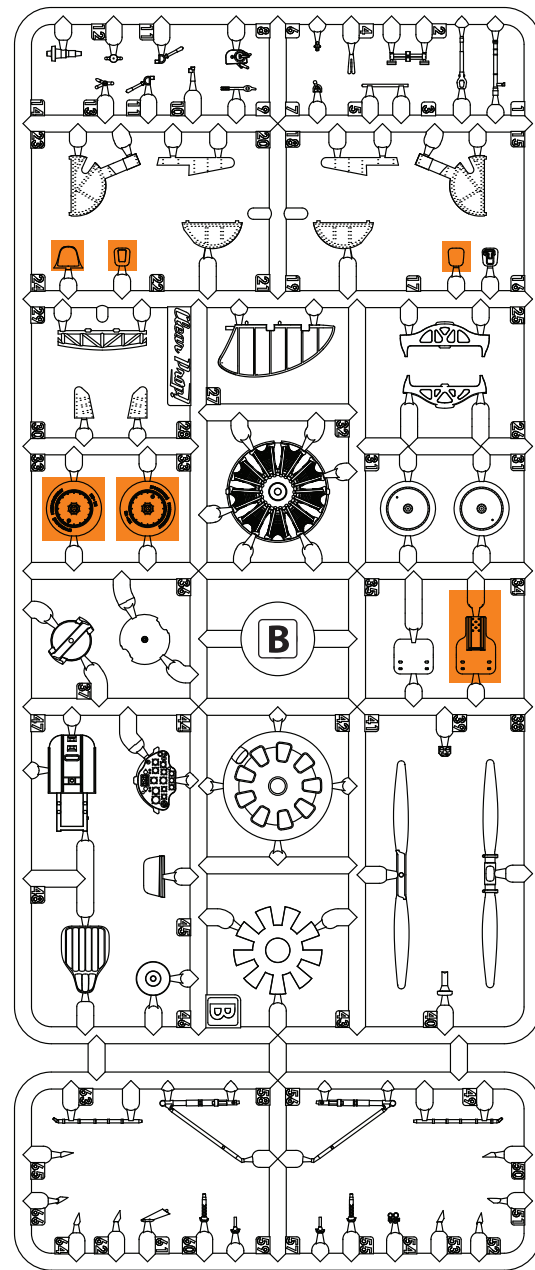
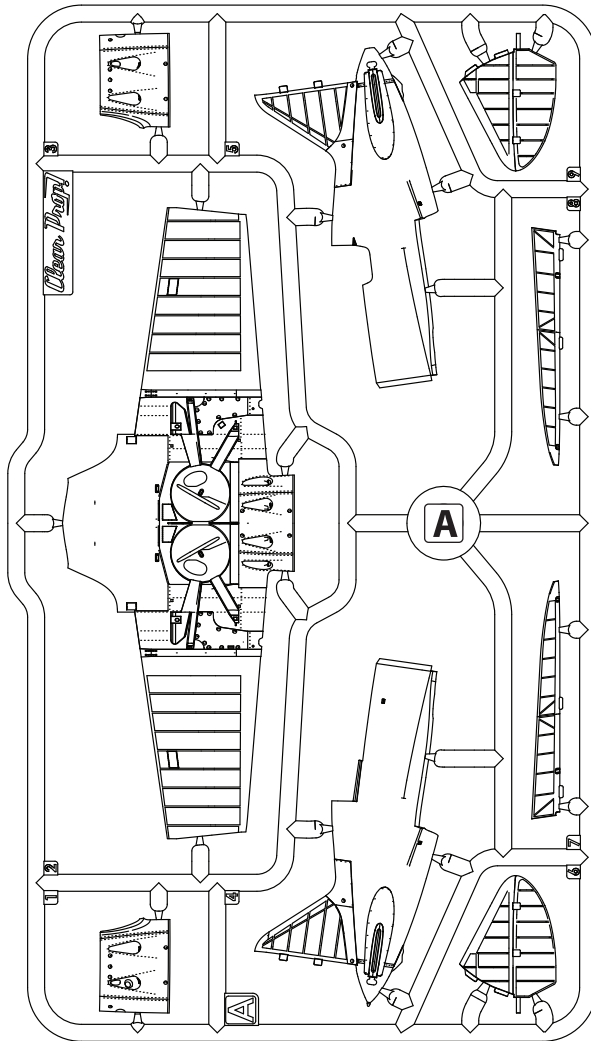

Parts not for use

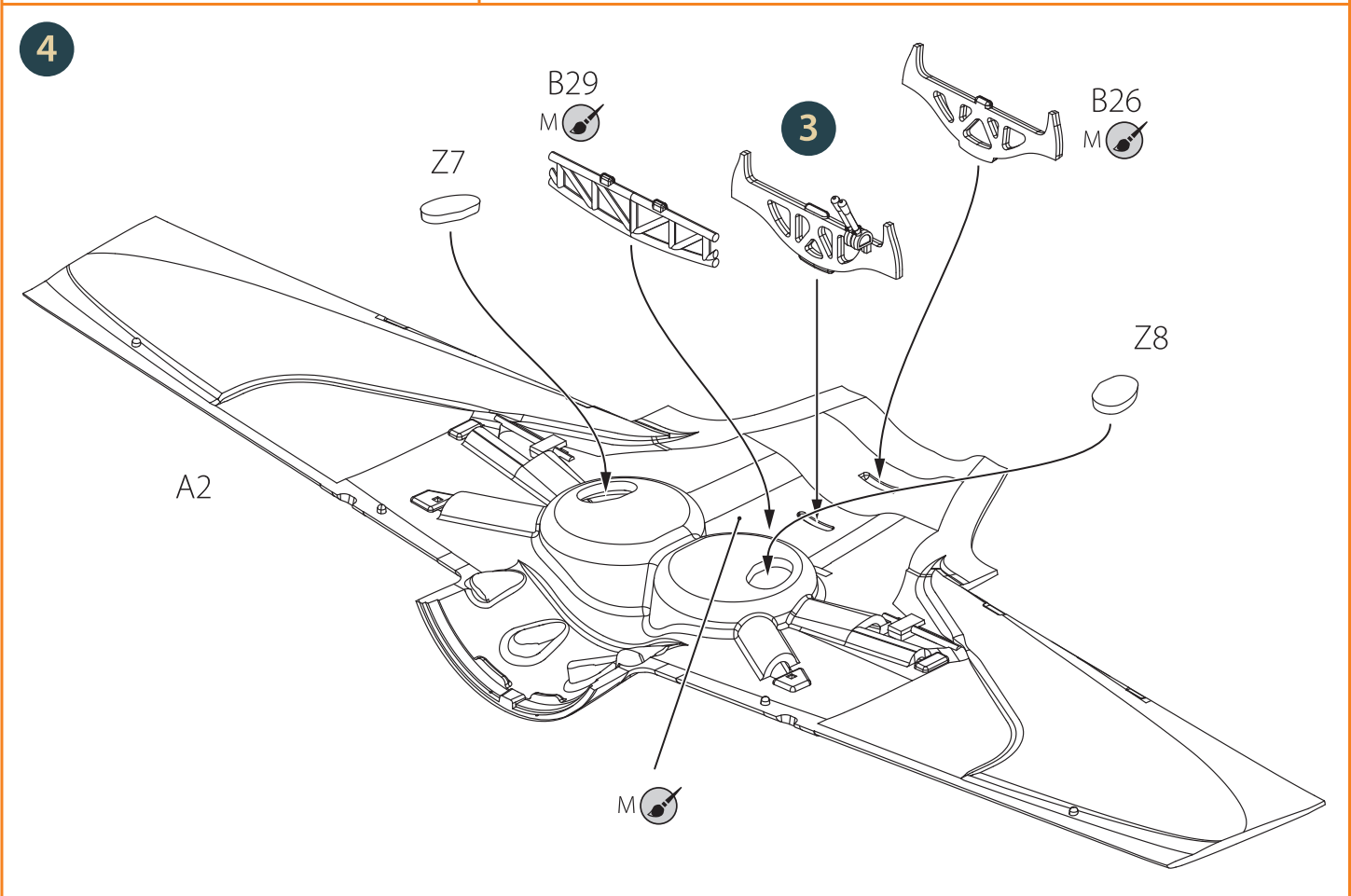
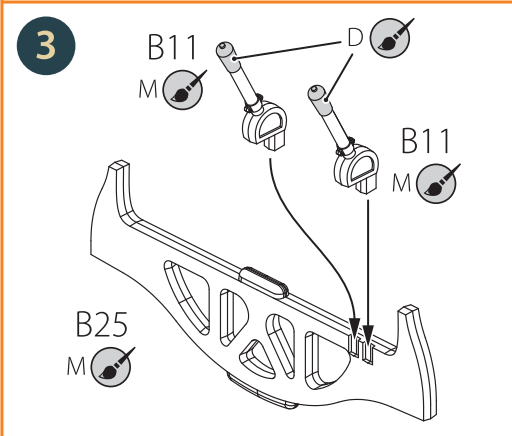
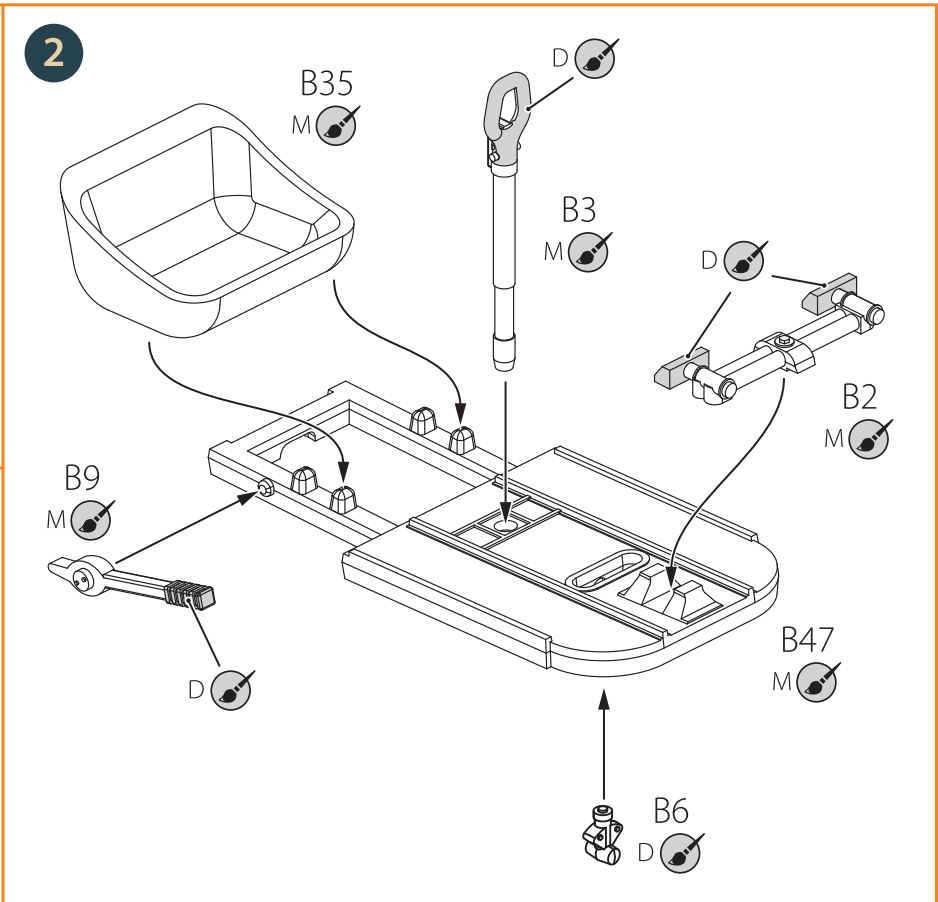
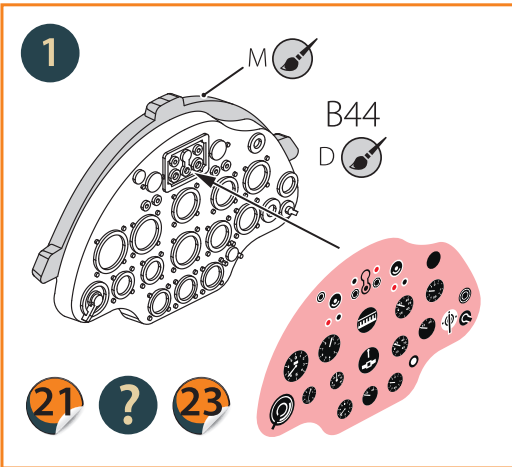

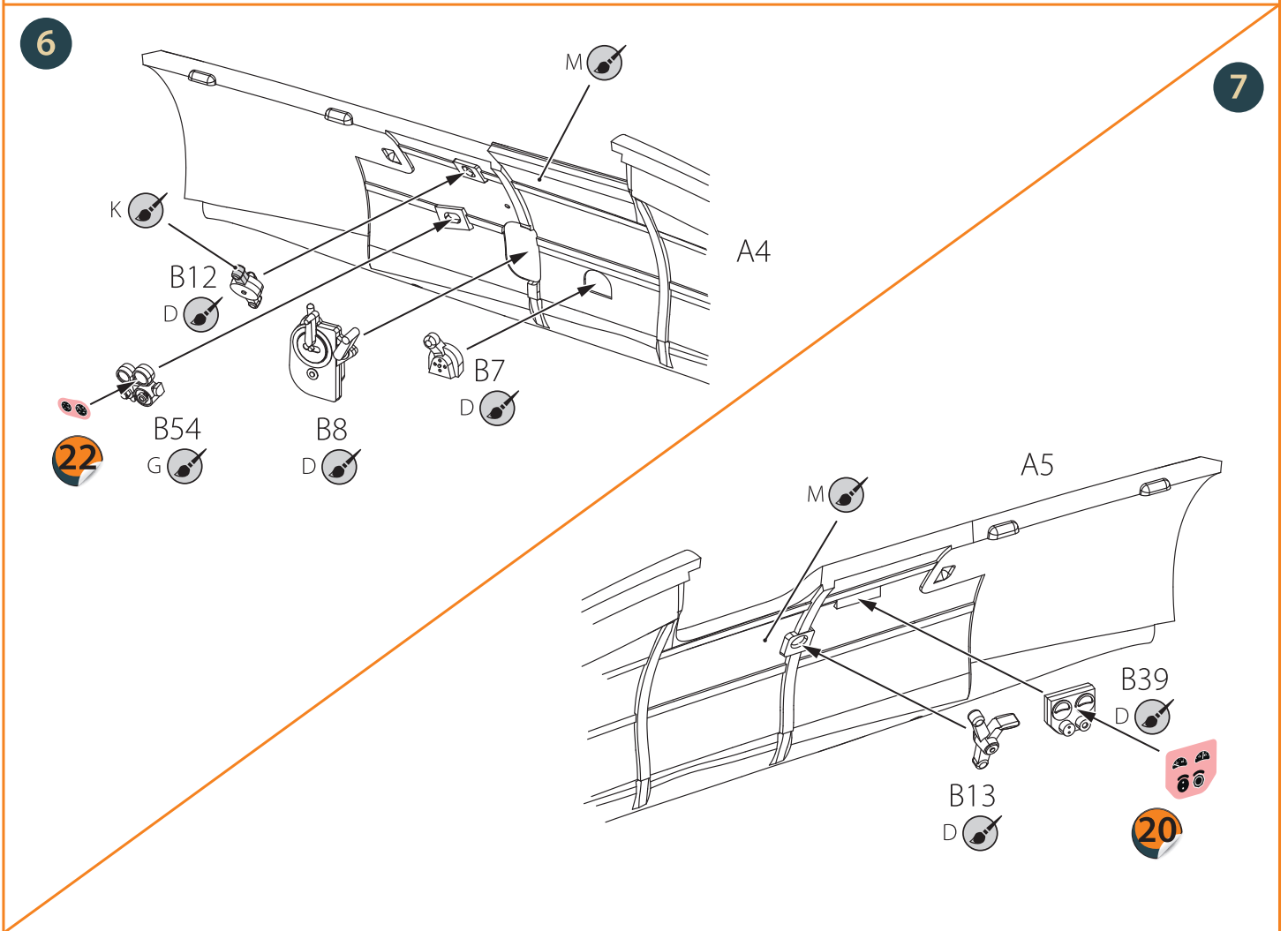
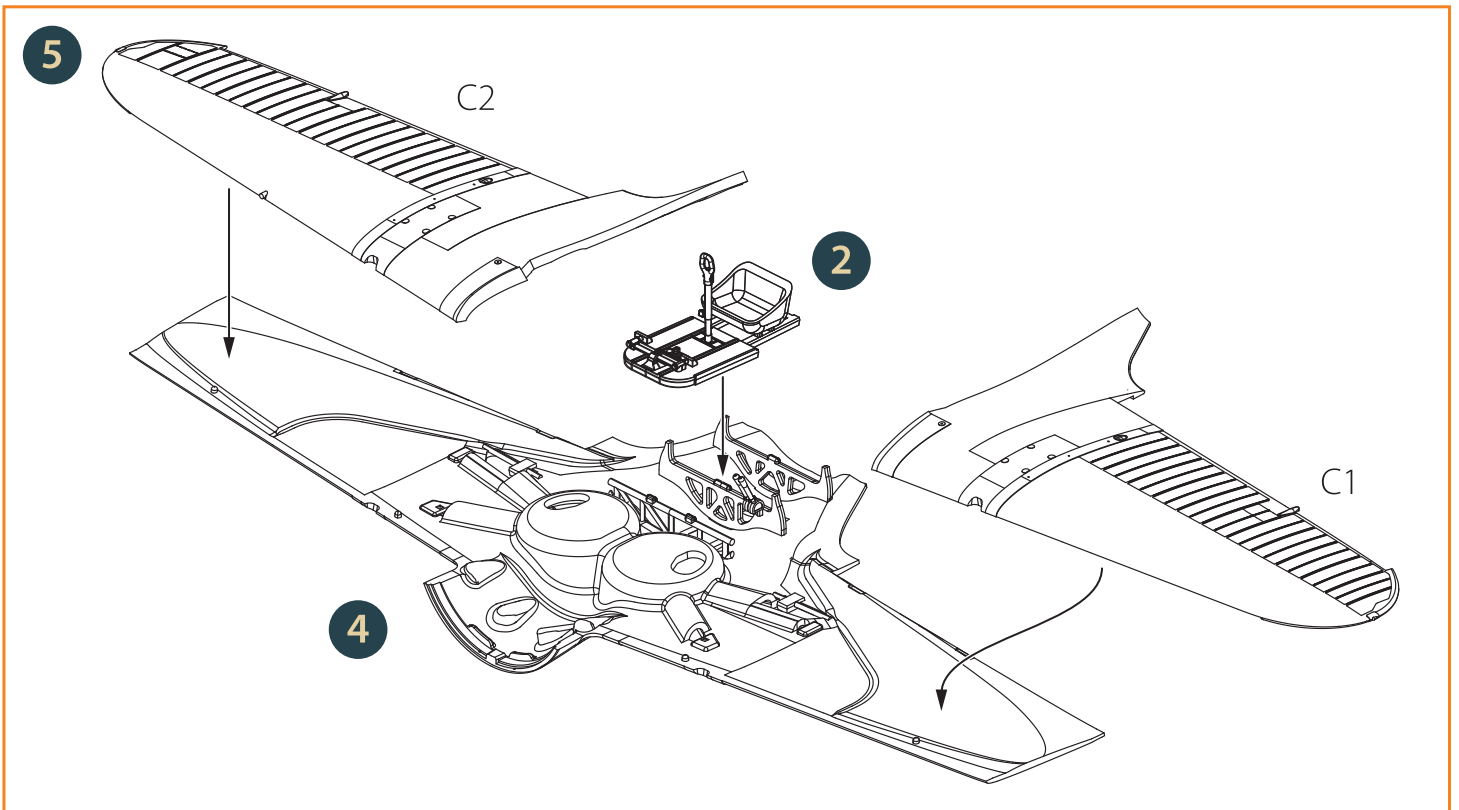

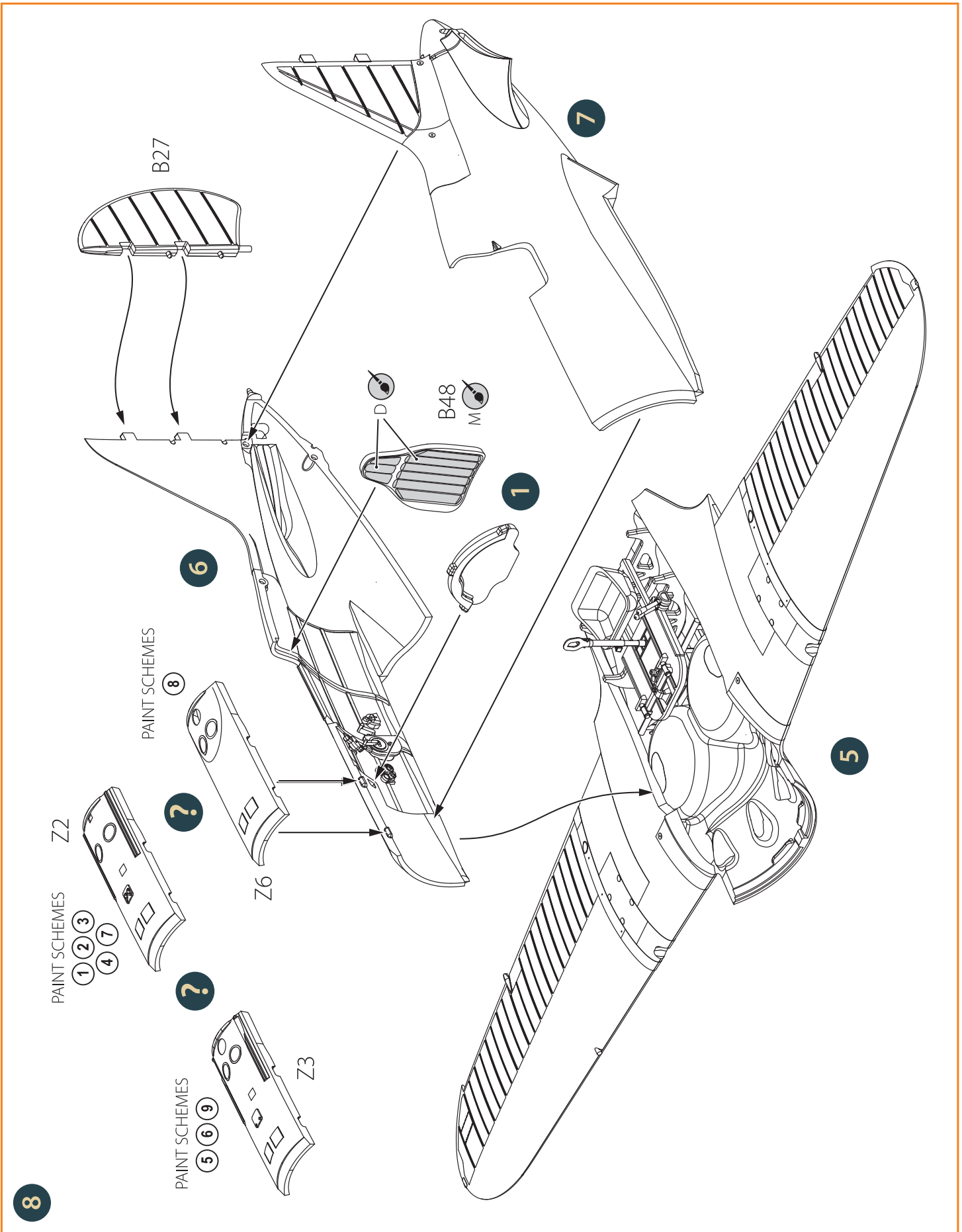

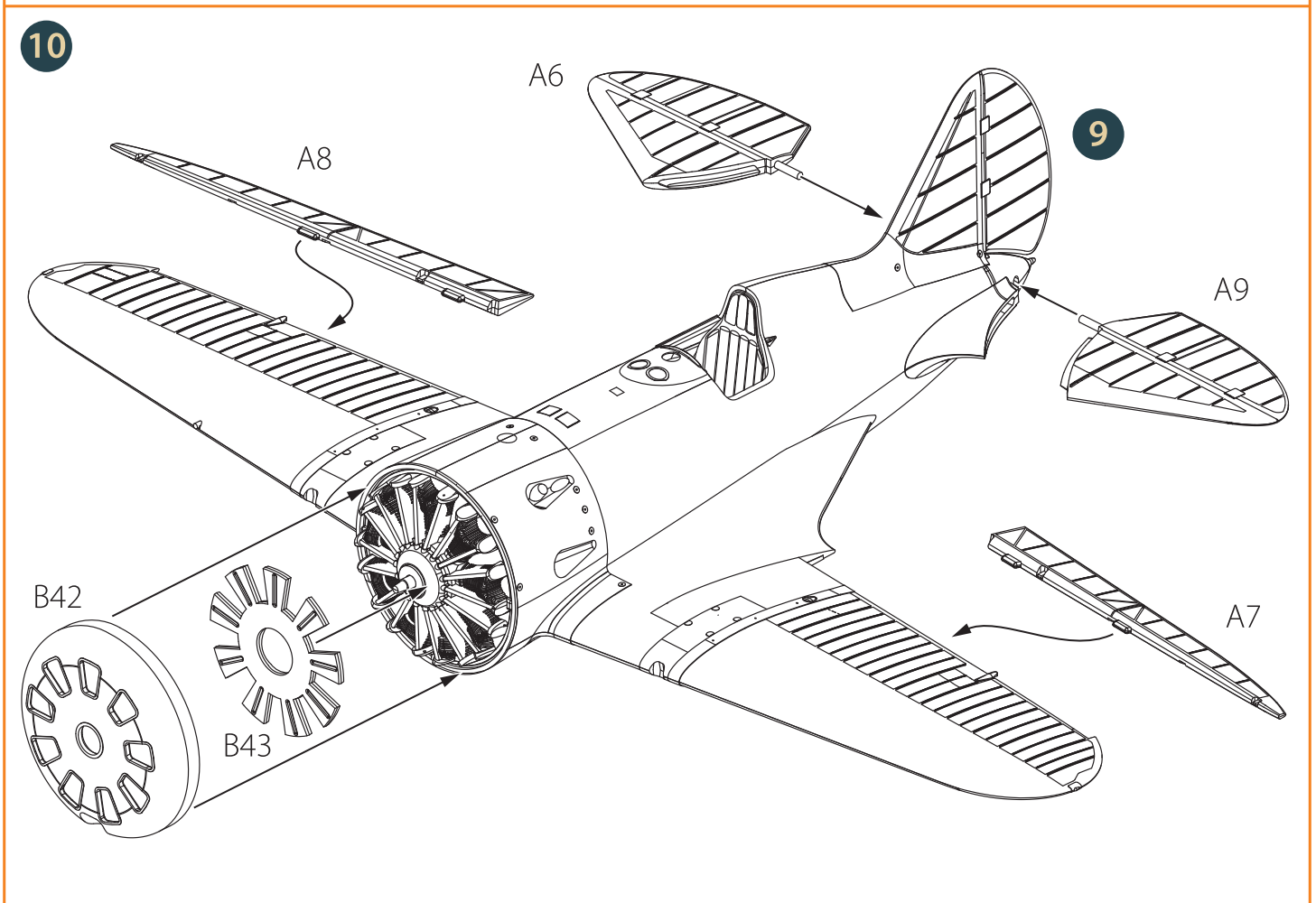
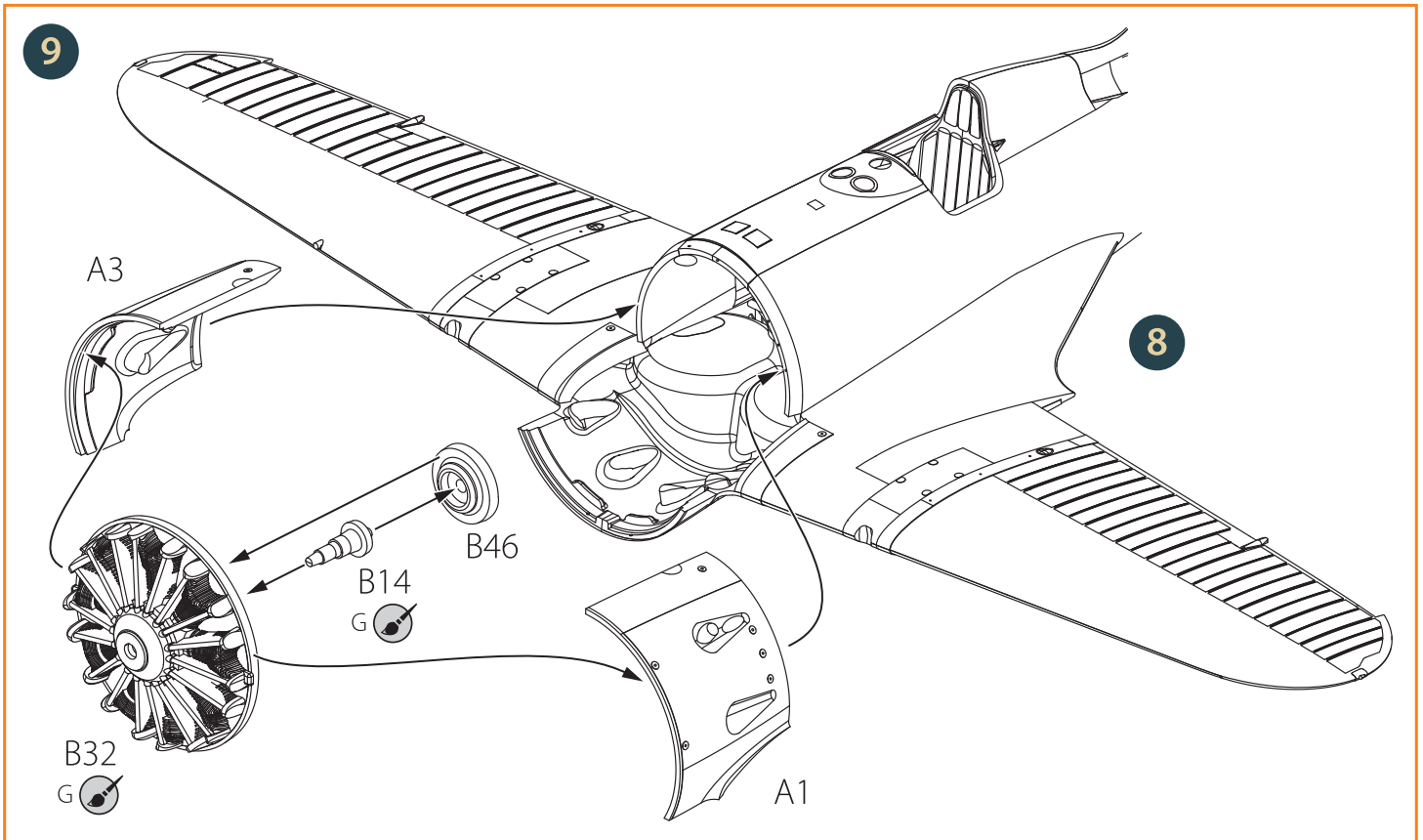

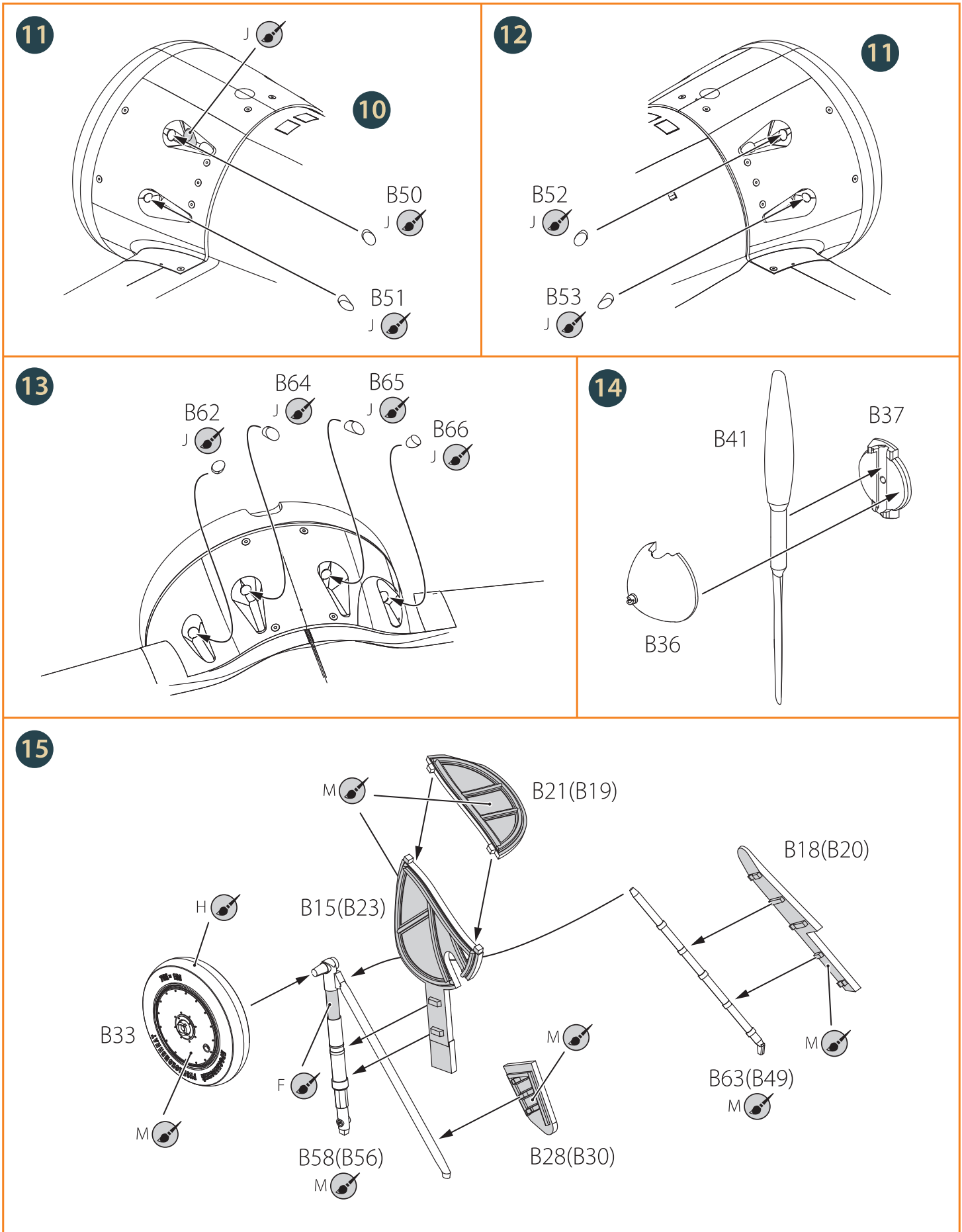

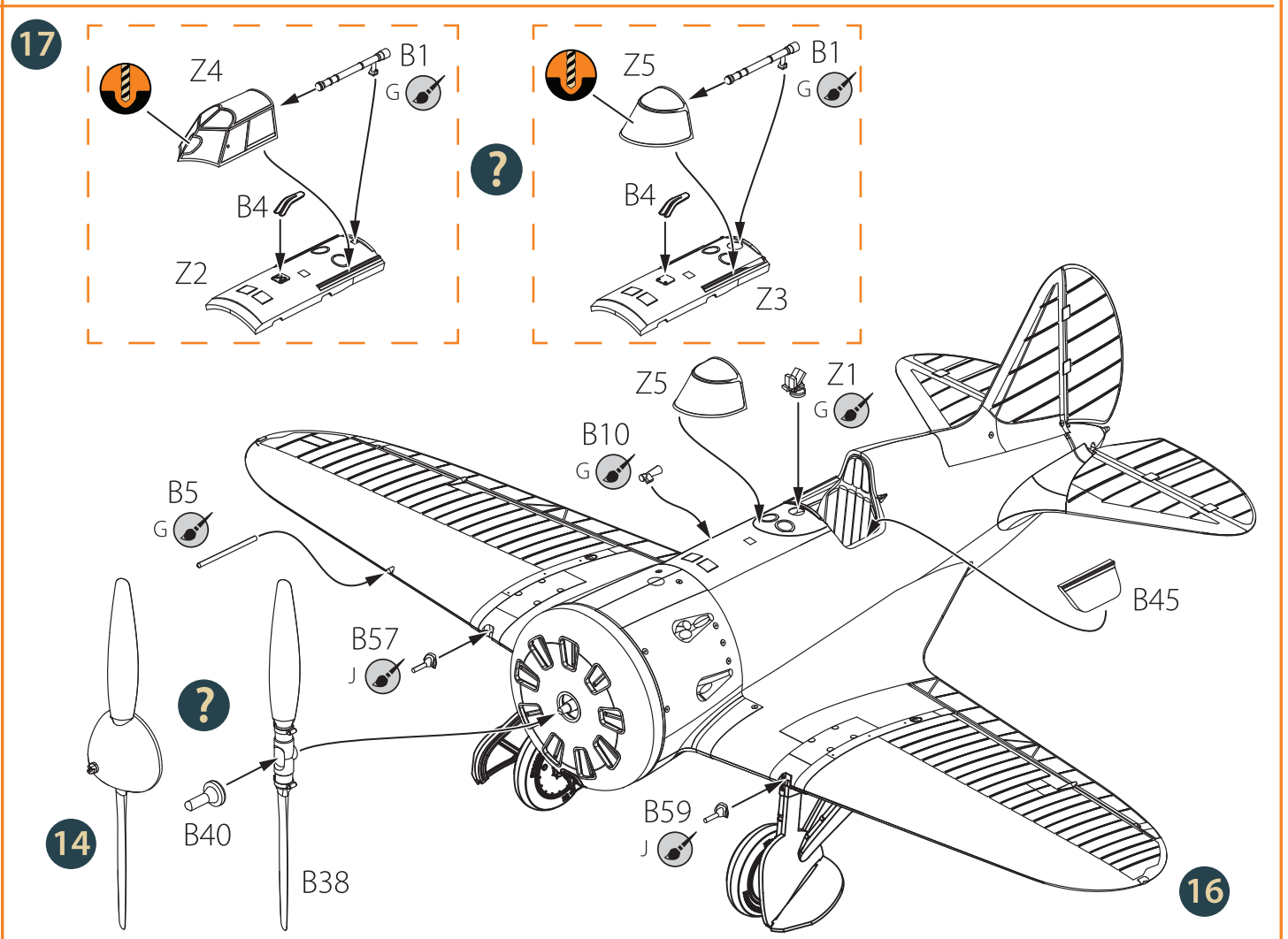
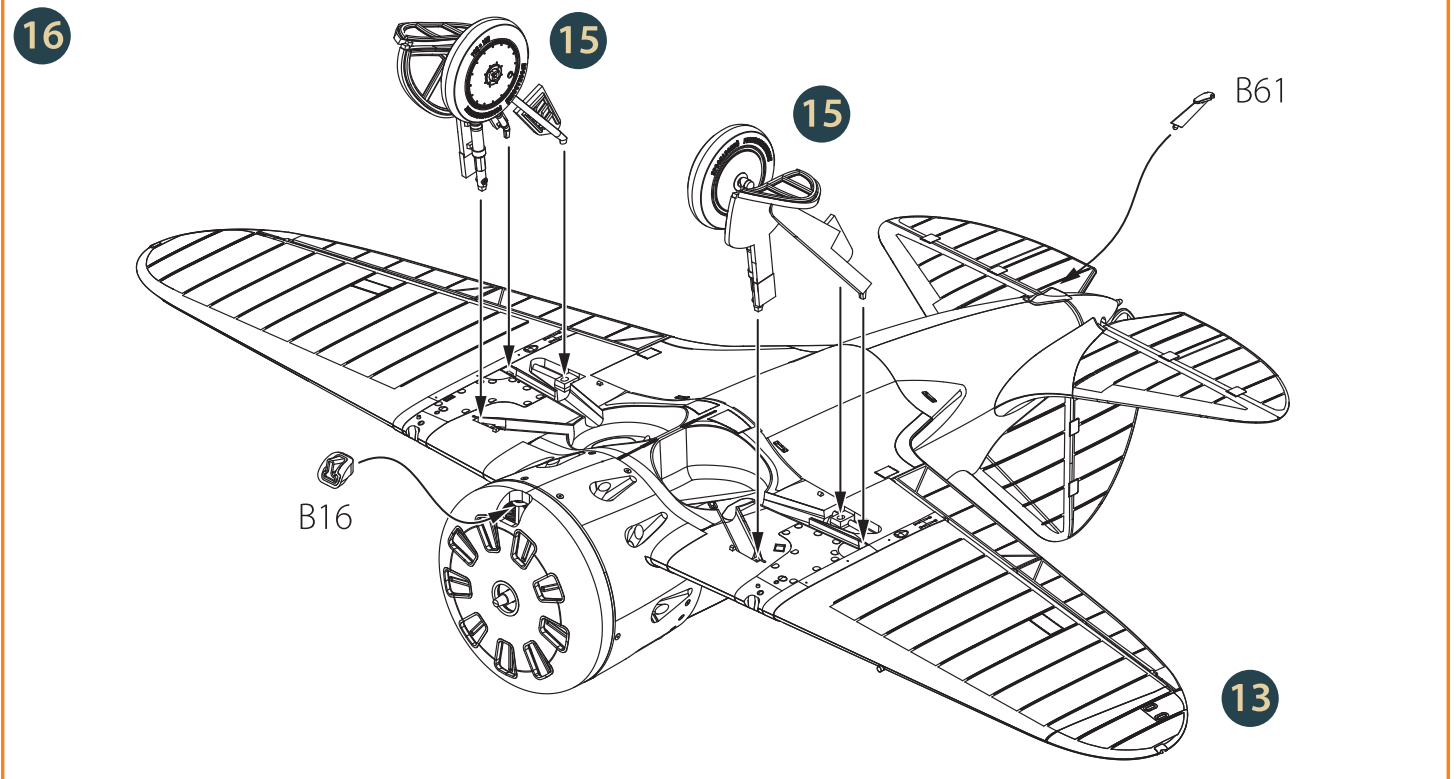

A	B	C	E	F	L	N	O	P
A.MIG-0080 AMT-4 GREEN	A.MIG-0046 AMT-6 BLACK	A.MIG-0224 SKY LINE BLUE	A.MIG-122 BONE	A.MIG-0191 POLISHED STEEL	A.MIG-0049 RED	A.MIG-0050 WHITE	A.MIG-257 AZURE BLUE	A.MIG-249 LIGHT BLUE

① I-16 type 5. 10 IAP, Siauliai. Baltic Military District, 1941.

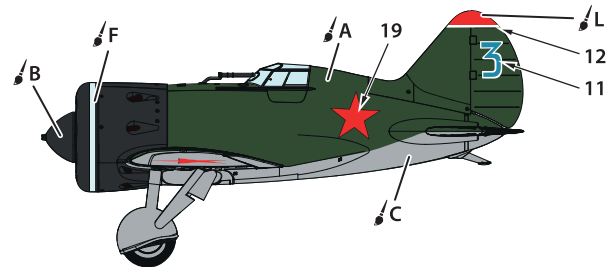
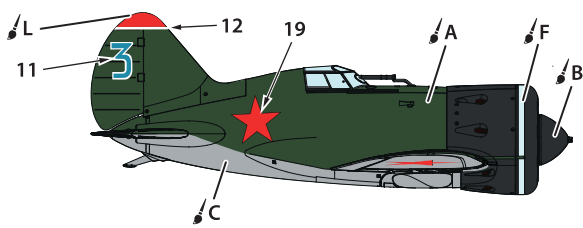

② I-16 type 5 from the movie "Fighter". Kyiv, Kyiv military district, 1939.

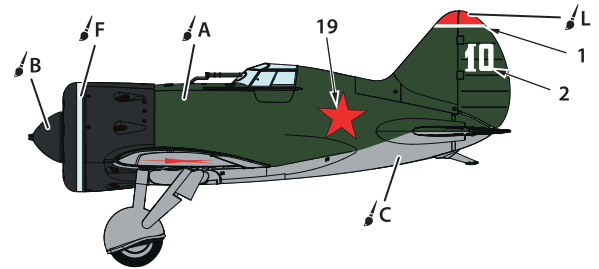
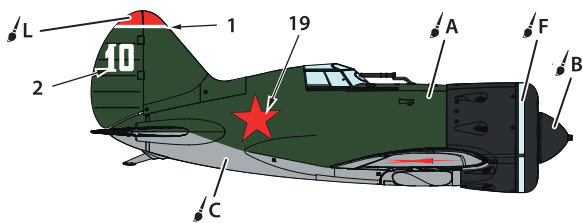

③ I-16 type 5. 46 IAP, Mlynow. Kyiv military district, 1941.

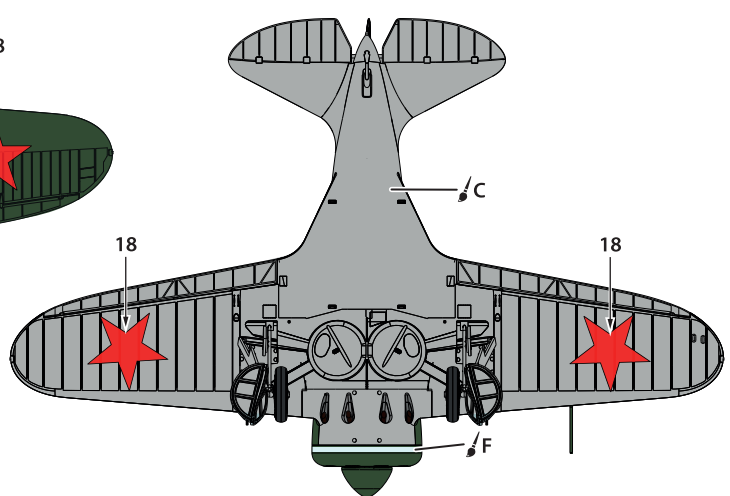
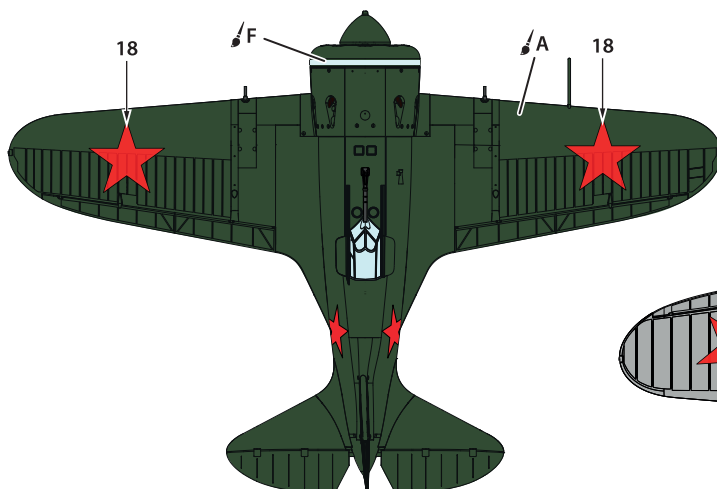
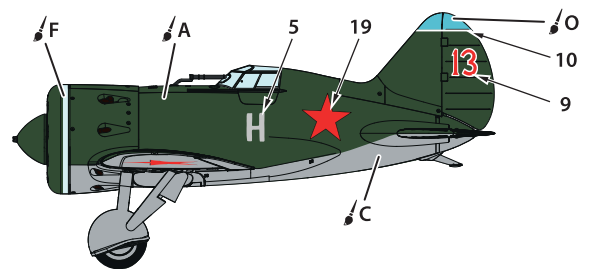
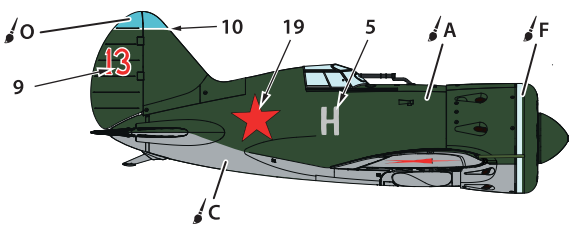

A	B	C	E	F	L	N	O	P
A.MIG-0080 AMT-4 GREEN	A.MIG-0046 AMT-6 BLACK	A.MIG-0224 SKY LINE BLUE	A.MIG-122 BONE	A.MIG-0191 POLISHED STEEL	A.MIG-0049 RED	A.MIG-0050 WHITE	A.MIG-257 AZURE BLUE	A.MIG-249 LIGHT BLUE

④ I-16 type 5. 20th GARDEN. Odessa military district, June 1941.

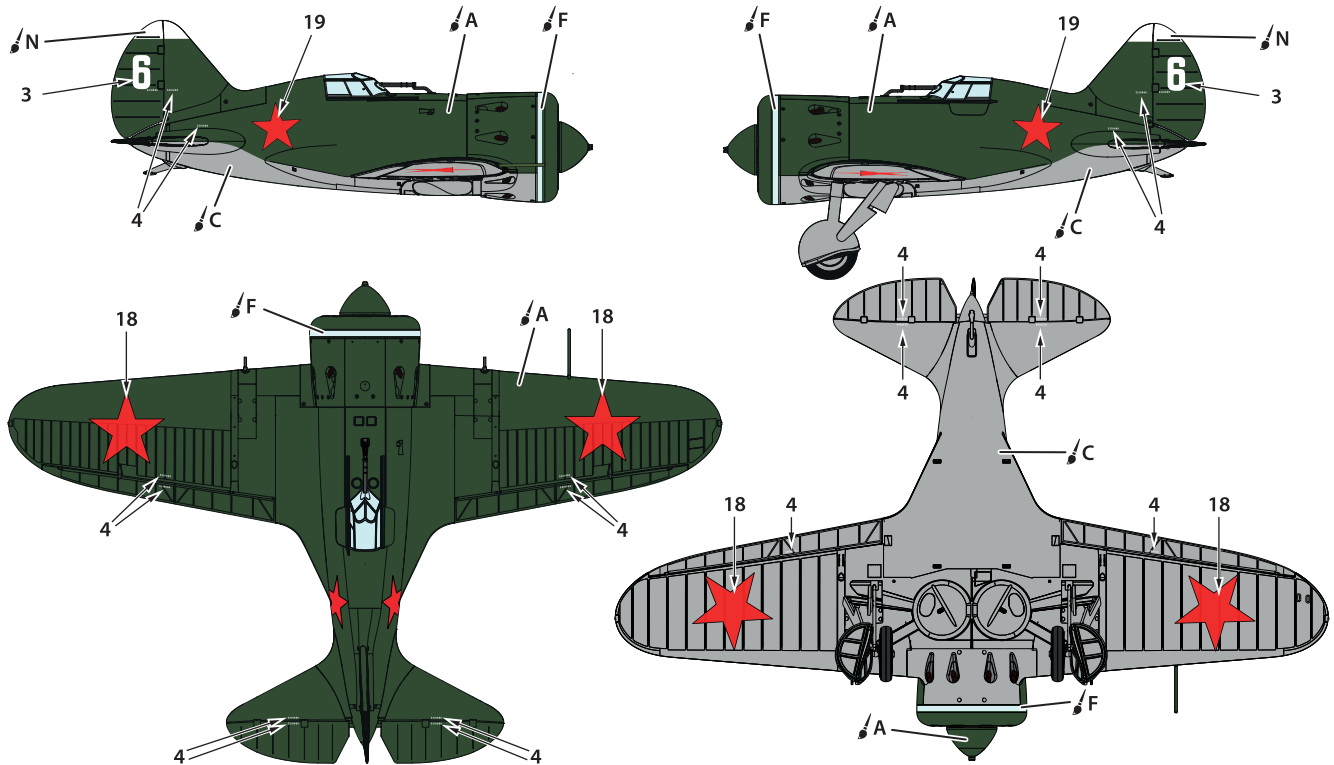

⑤ I-16 type 5. 2 AE. 26th IAP. Soviet-Finnish war, February 1940.

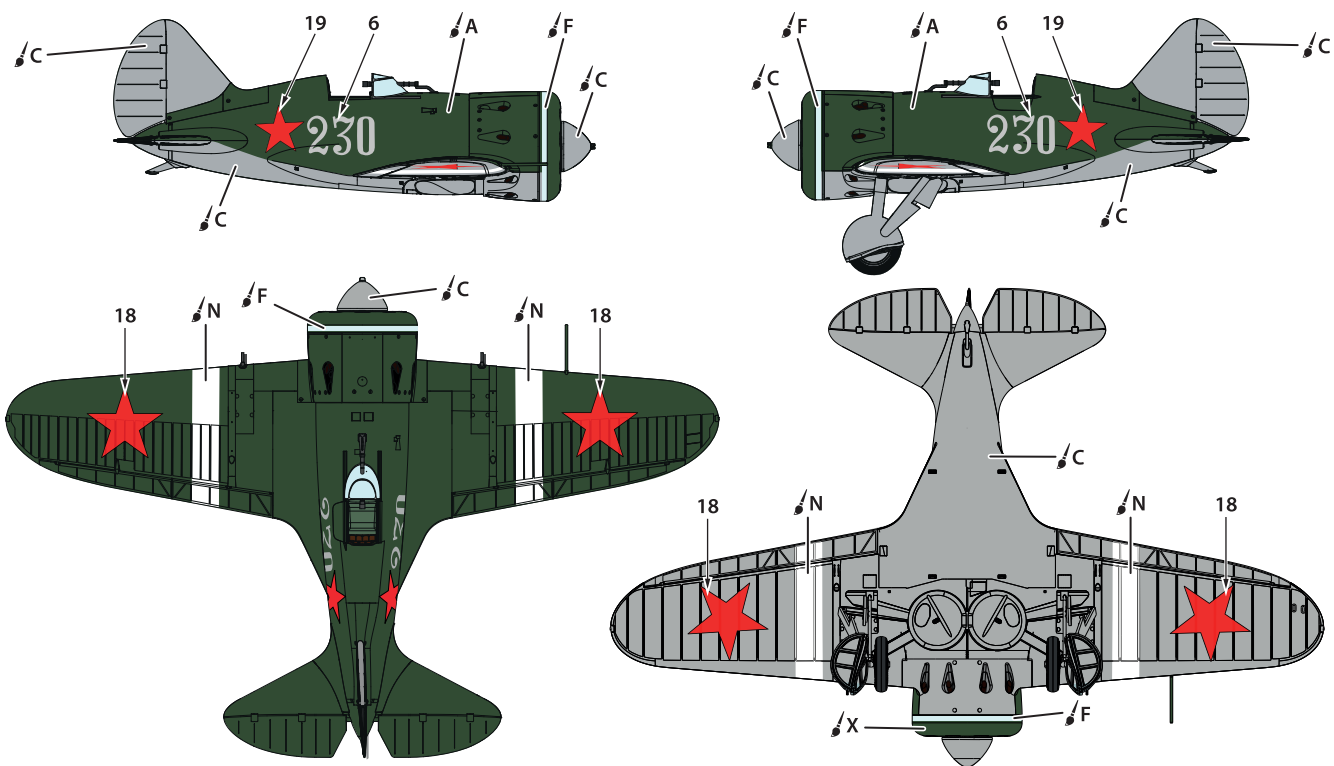

A	B	C	E	F	L	N	O	P
A.MIG-0080 AMT-4 GREEN	A.MIG-0046 AMT-6 BLACK	A.MIG-0224 SKY LINE BLUE	A.MIG-122 BONE	A.MIG-0191 POLISHED STEEL	A.MIG-0049 RED	A.MIG-0050 WHITE	A.MIG-257 AZURE BLUE	A.MIG-249 LIGHT BLUE

⑥ I-16 type 5. 2 AE. 26th IAP. Soviet-Finnish war, February 1940.

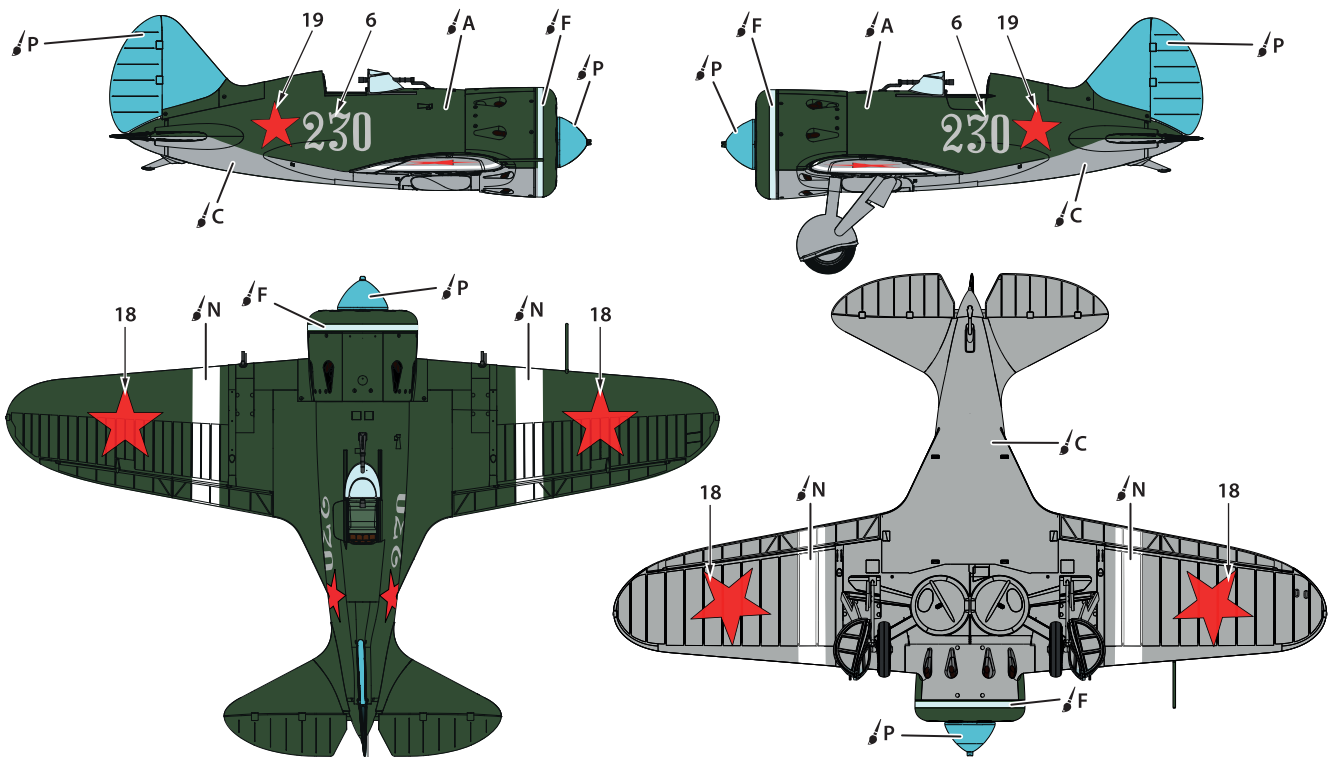

⑦ I-16 type 5. 43 IAD, Orsha. Western military district, 1941.

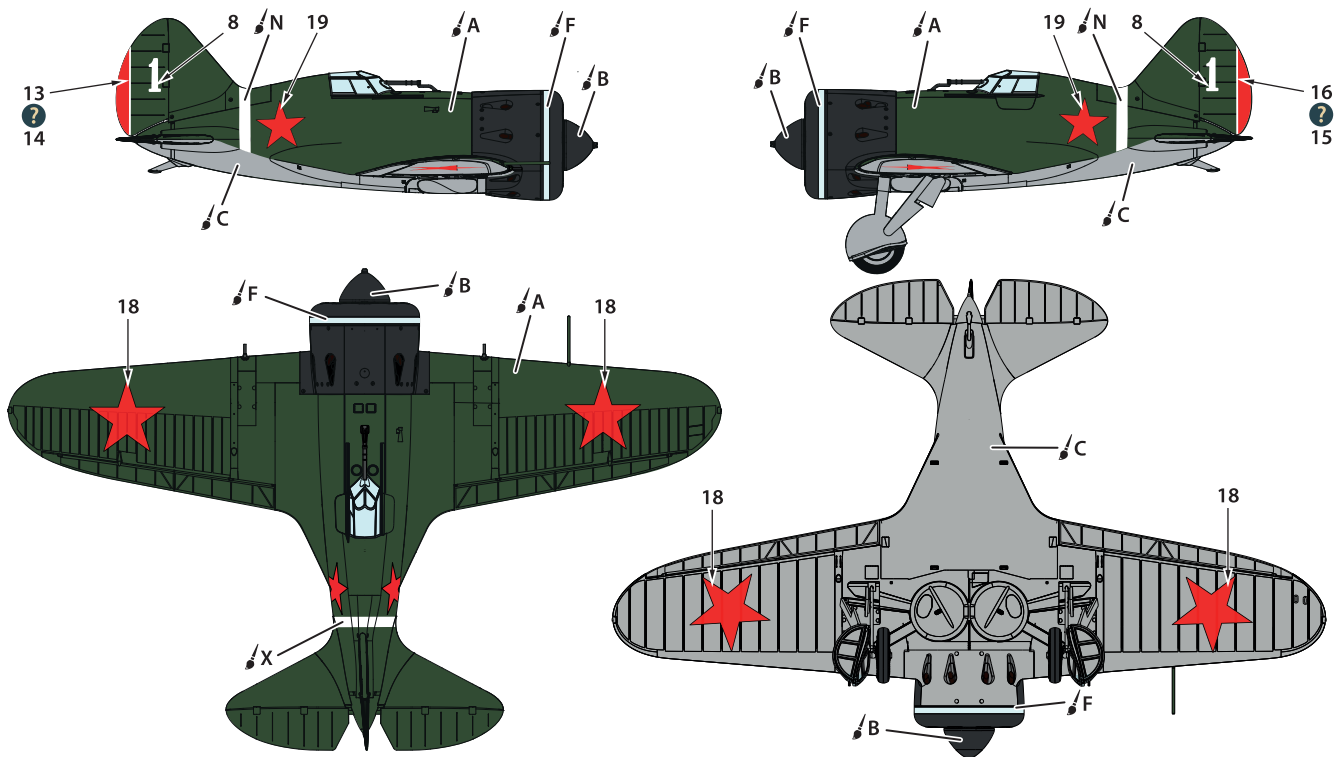

A	B	C	E	F	L	N	O	P
A.MIG-0080 AMT-4 GREEN	A.MIG-0046 AMT-6 BLACK	A.MIG-0224 SKY LINE BLUE	A.MIG-122 BONE	A.MIG-0191 POLISHED STEEL	A.MIG-0049 RED	A.MIG-0050 WHITE	A.MIG-257 AZURE BLUE	A.MIG-249 LIGHT BLUE

⑧ I-16 type 5. 33 IAP, Pruzhany. Western military district, 1941.

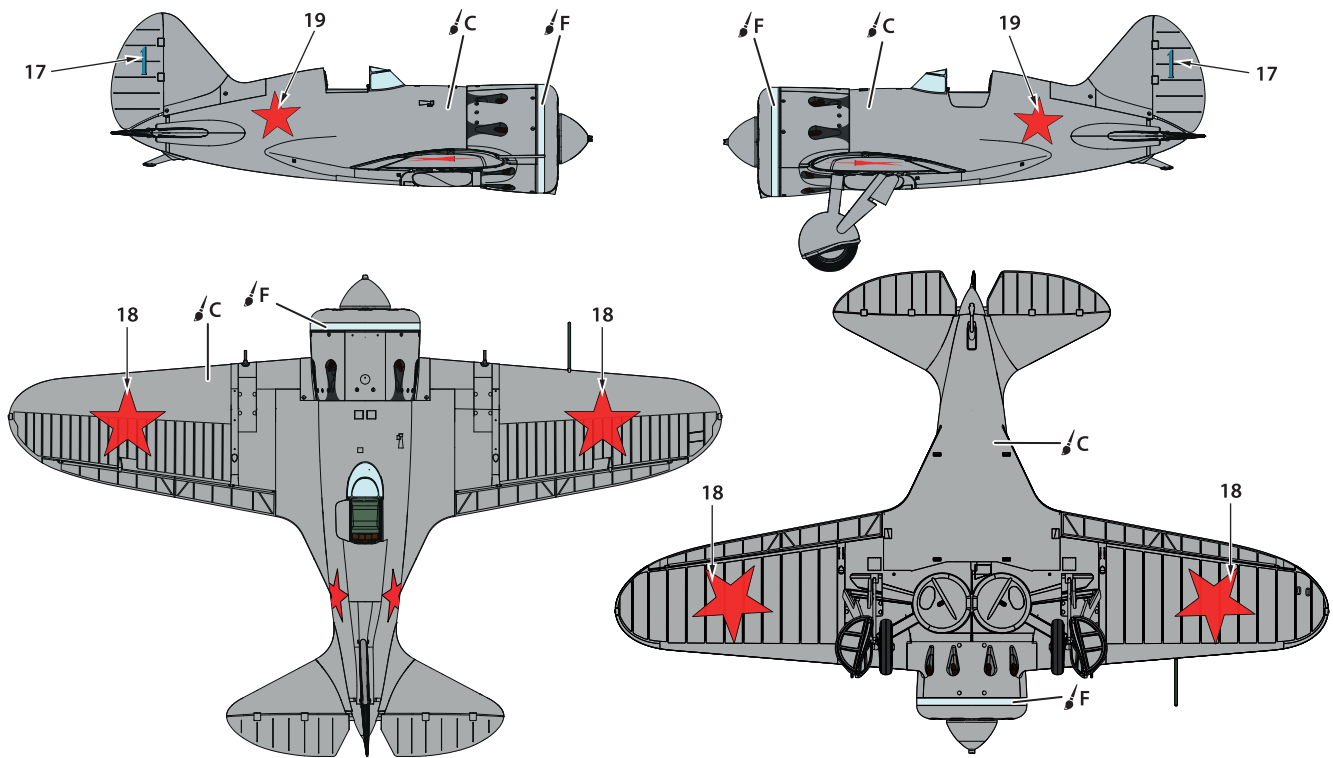

⑨ I-16 type 5. One of the aviation schools of the Western Military District. Bobruisk, June 1941.

