

The "Bristol" Aeroplanes

THE BRITISH & COLONIAL AEROPLANE CO., LTD
FILTON, BRISTOL

ASSEMBLY MANUAL

OF

"BRISTOL" SCOUT BIPLANE

"C" TYPE.

SCALE: 1/32

MARCH, 2023.

CSM SIA, Latvia 2023



The Bristol Scout was designed as a part-time project by Frank Barnwell in late 1913 to meet the military requirement for a fast unarmed single-seat tactical scout. Two examples (Type B) were given to the Royal Flying Corps in July 1914 and proved so fast and manoeuvrable that the pilots experimented fitting rifles to attack enemy machines. In late 1914 both Royal Flying Corps and Royal Naval Air Service placed orders for more, and Barnwell redesigned the fuselage and called it the Type C. Deliveries started in February 1915, generally being supplied in ones and twos to each squadron. The only exception appears to have been No. 2 Wing RNAS in the Eastern Mediterranean, which had around half a dozen operational at any one time. Total production of all four types (A, B, C & D) was 375.

It was the fastest and most manoeuvrable aircraft on either side in the first 18 months of the war, and they proved extremely popular with pilots, some of whom devised their own gun mounts for air-to-air combat. The best known example is 1611 for which Lanoe Hawker devised the oblique mounting firing just clear of the propeller with which he obtained the first VC for aerial combat, forcing down three enemy aircraft in one flight. No. 2 Wing RNAS mounted Lewis guns firing unsynchronised through the propeller and replaced the propeller regularly. Albert Ball scored his first victory in a Bristol Scout, probably using a Lewis gun mounted on the top wing.

A few examples were fitted at the factory with synchronised Vickers guns but the cockpit was too small to make this practical. It was also used experimentally. 1255 was the first wheeled aircraft to take off from a moving ship in November 1915, and six months later 3028 was the first aircraft to take off from another aircraft when it was fitted to a mounting on the top wing of the Porte Baby seaplane.

Many modifications of armament, airframe, engine and colour scheme were made to them, either at the factory or at the front, so photographic evidence is the only way to ensure historical accuracy. Only four examples exist today; static examples in the UK at the Fleet Air Arm museum in Yeovilton and the Bristol Aerospace museum at Filton, and airworthy examples at Ardmore airfield, Auckland, NZ, and the Shuttleworth Collection, Bedfordshire, UK.

David Bremner

Important Notes

- Read the instruction carefully before starting assembly.
- Use glue intended for plastic models.
- Choking hazard. Keep small parts and plastic bags away from children.
- Always wear protective eyewear when cutting and a protective mask when painting, glueing and sanding.
- Use paints designed and suitable for plastic model kitsets.

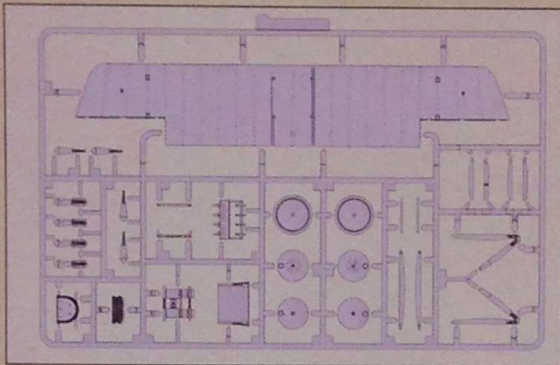

Runner A

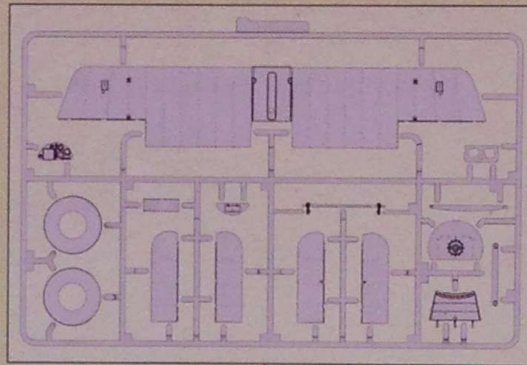

Runner B

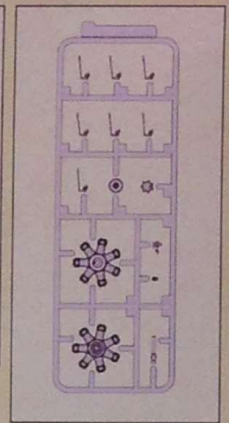

Runner E

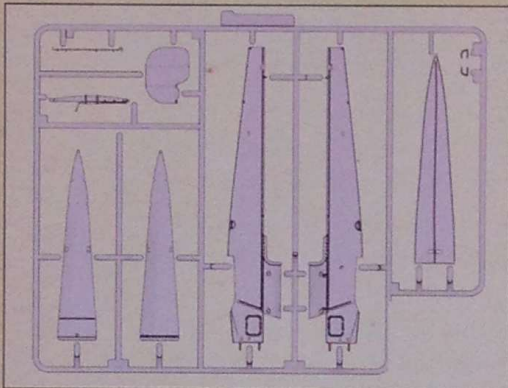

Runner C

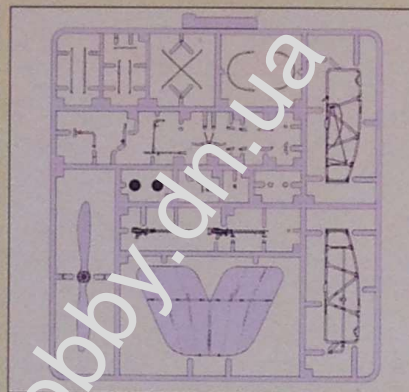

Runner D

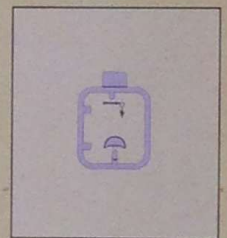

Runner F

Colour numbers

1 Brass	7 Leather	13 Pc10
2 Aluminum	8 Light wood	14 Red brown varnish
3 Copper	9 Dark wood	15 Clear doped linen
4 Steel	10 Rubber (dark)	16 Gun metal
5 Black	11 Fabric	17 Plywood
6 White	12 Dark yellow	18 Buff

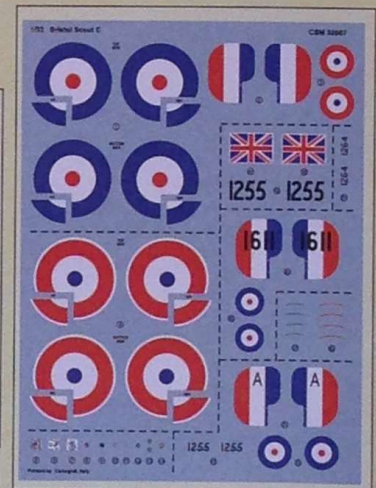

Decals

Symbols Reference

B.16 11801 Jaeger tachometer	Part number Real part number (if applicable) Part name	Other side	Cut/Remove
5	Paint colour	PE.1	Photo etch part
	Apply decal	Attention	Drill
		Option	



Photo Etch

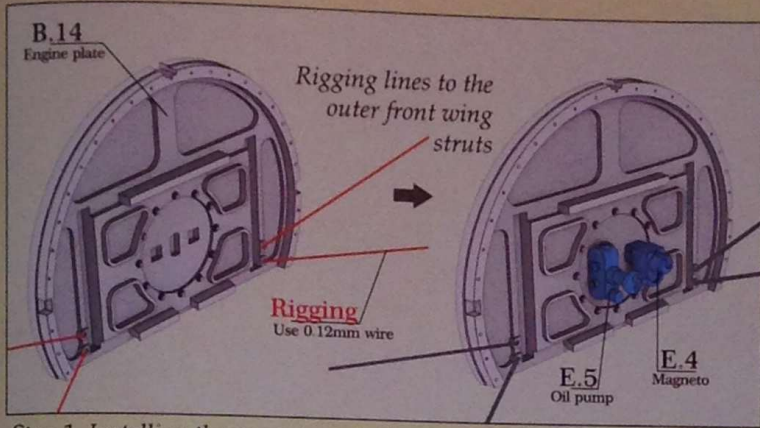

Step 1. Installing the magneto and oil pump on the engine plate

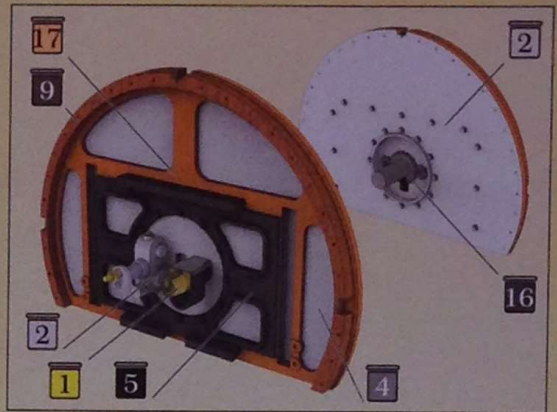
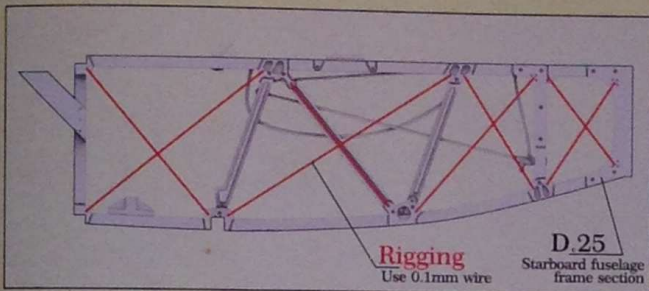
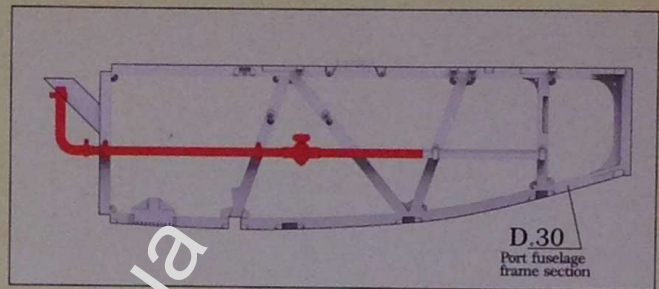

Fig. 1. Painting guide for the engine plate



Step 2. Adding the rigging to the fuselage frame section



Step 3. Remove the oil pipe for markings page 18 (1264)

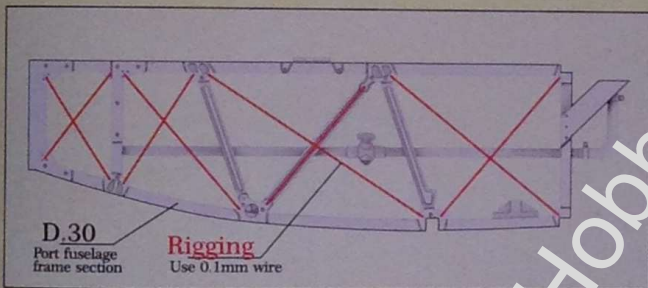

Step 4. Adding the rigging to the fuselage frame section

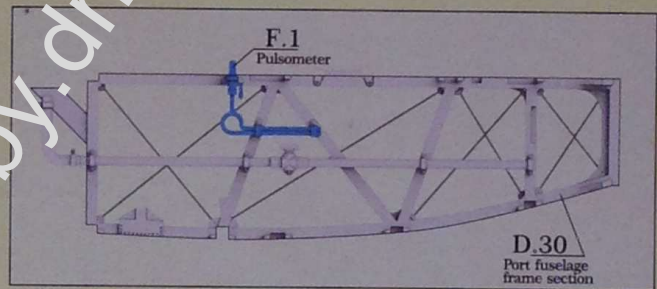

Step 5. Adding the pulsometer

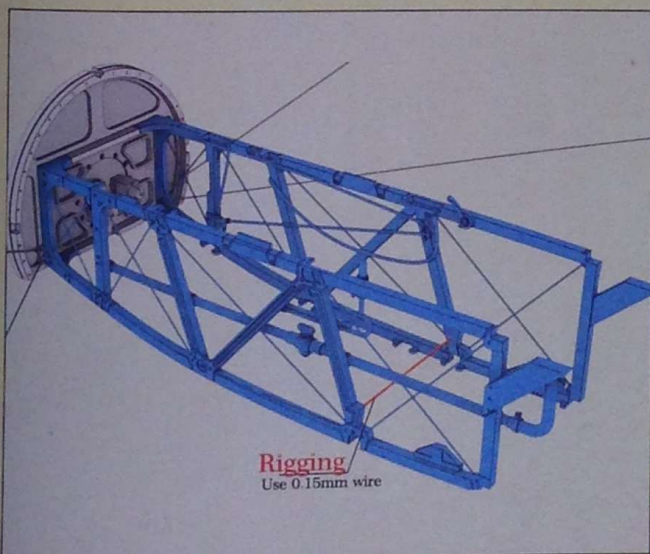

Step 6. Installing the fuselage frame sections

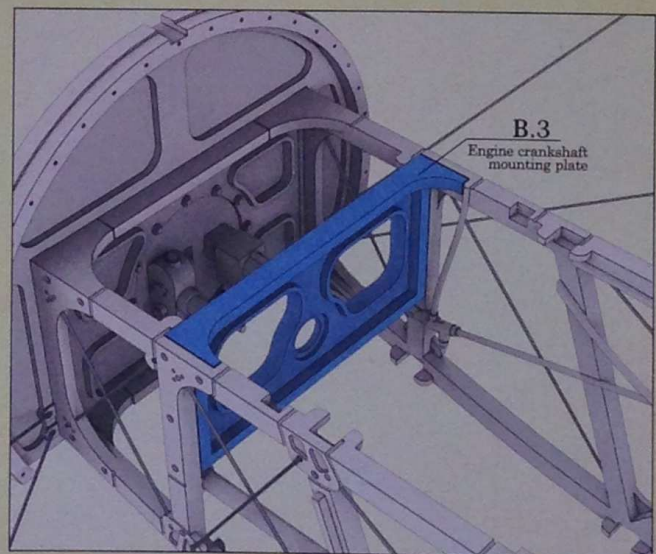

Step 7. Installing the crankshaft mounting plate

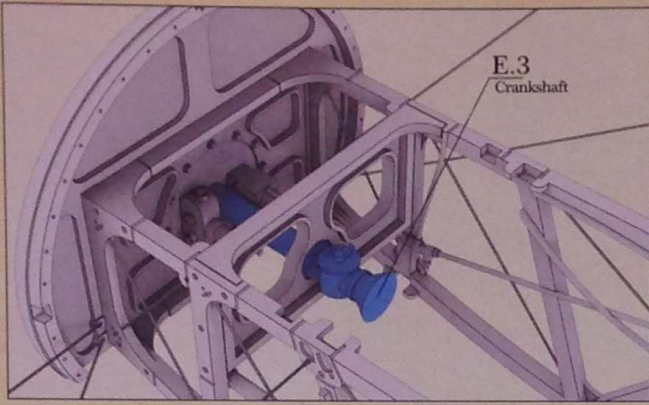

Step 8. Installing the crankshaft

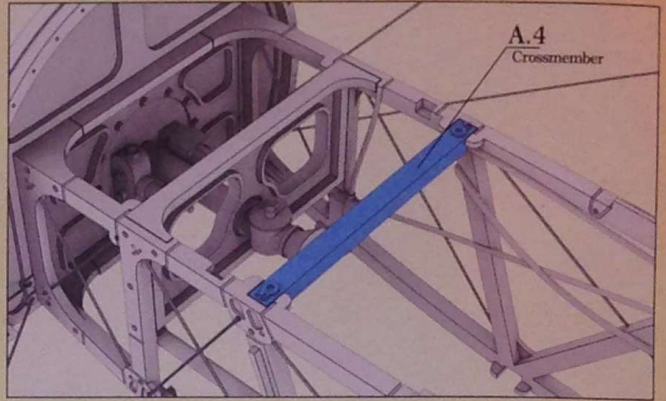

Step 9. Installing the crossmember

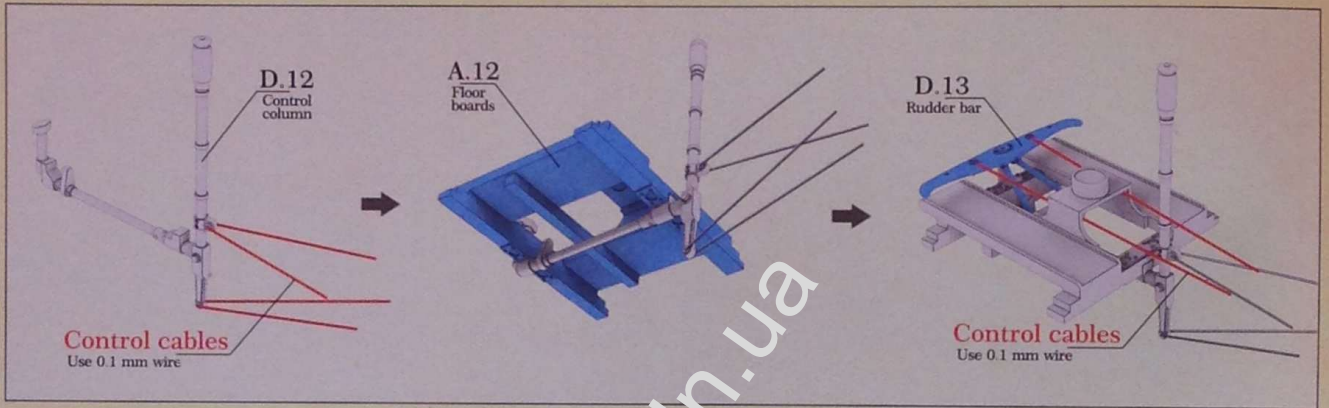

Step 10. Assembling the foot plates and rudder bar

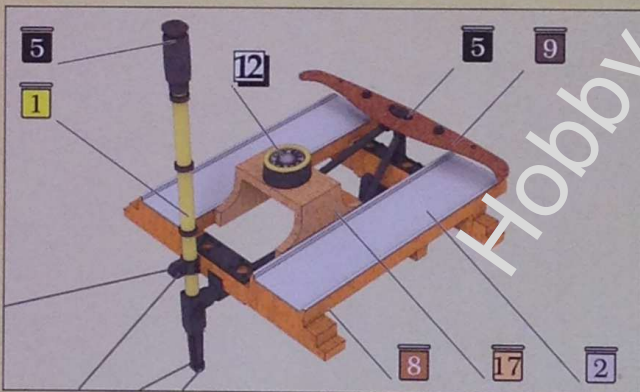
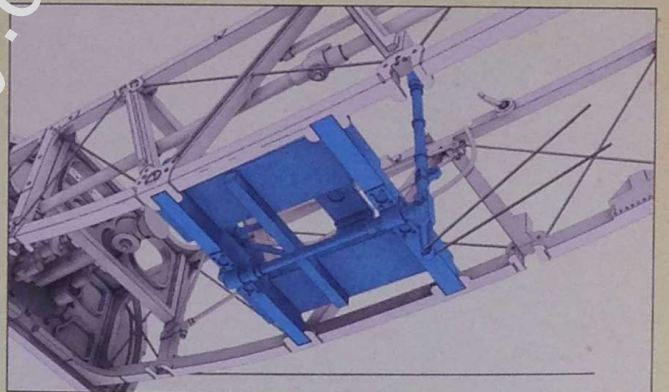
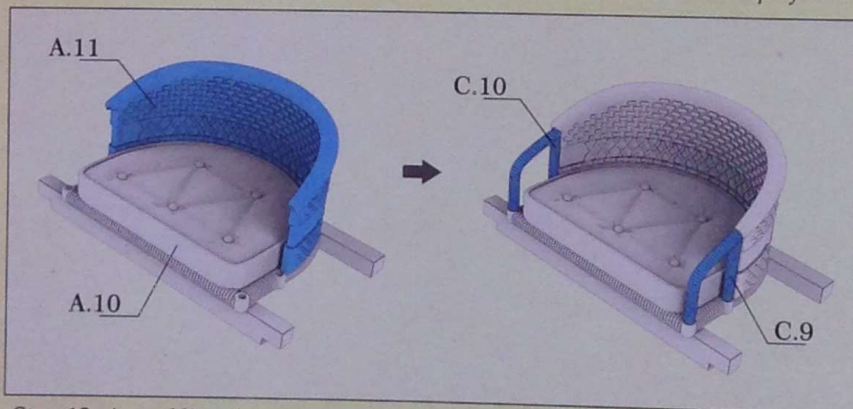

Fig. 2. Decals and painting guide for the rudder bar and foot plates



Step 11. Installing the rudder bar and foot plates assembly into the cockpit frame



Step 12. Assembling the pilot seat

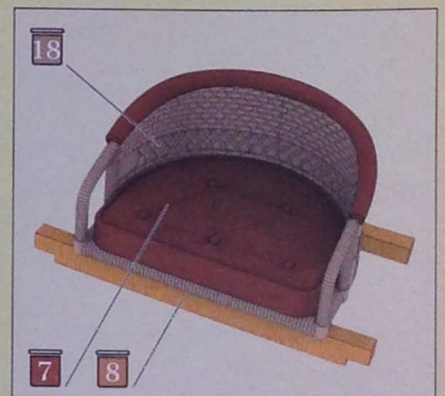
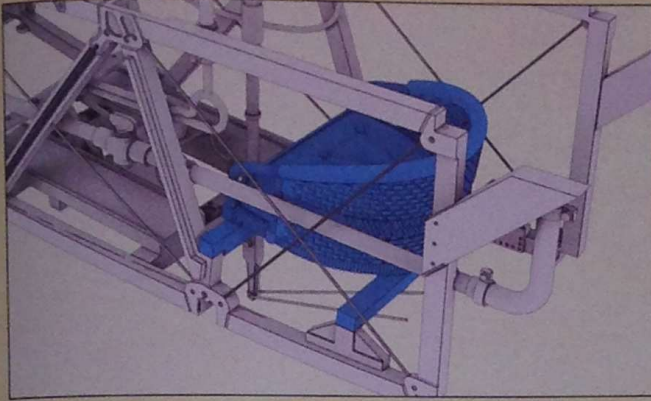
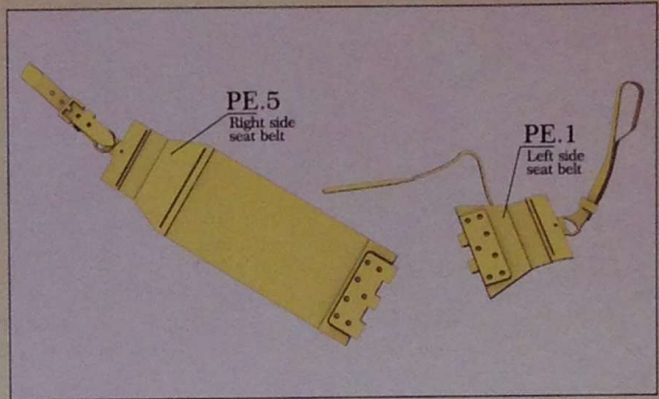

Fig. 3. Painting the pilot seat



Step 13. Installing the pilot seat



Step 14. Seat belts assembly

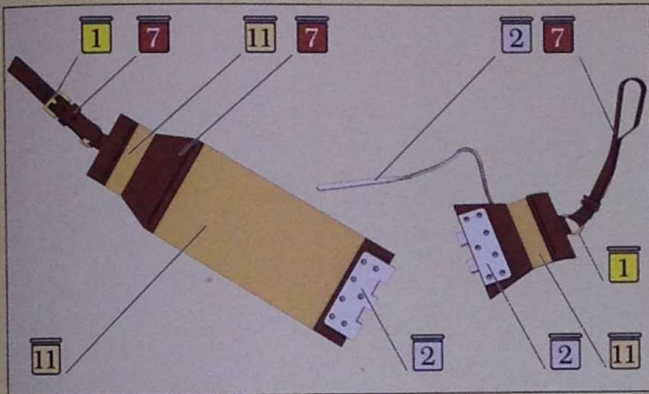
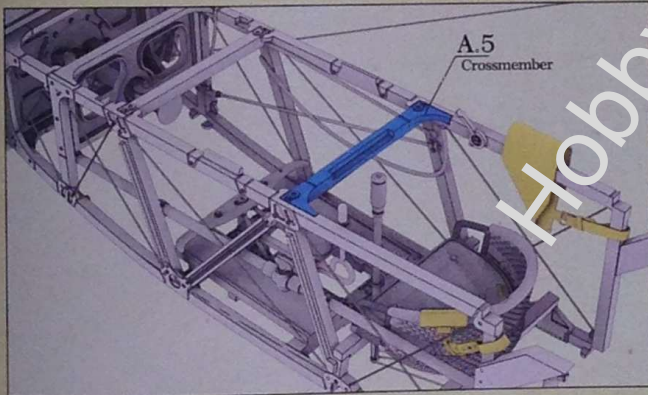

Fig.4. Painting guide for the seat belts



Step 15. Adding the seat belts



Step 16. Installing the crossmember

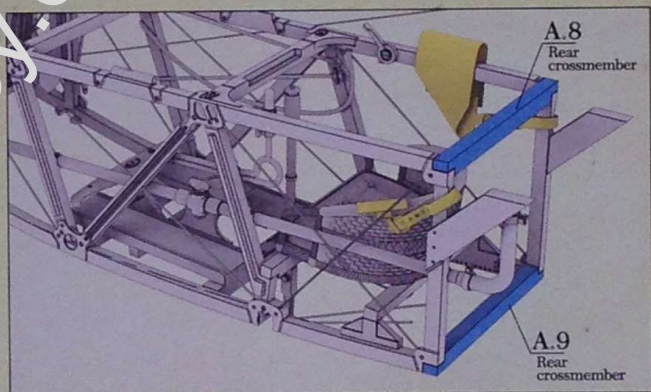

Step 17. Installing the crossmembers

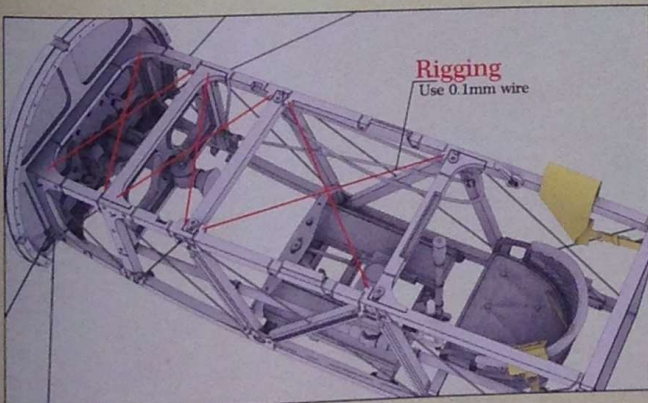

Step 18. Adding the rigging to the fuselage frame

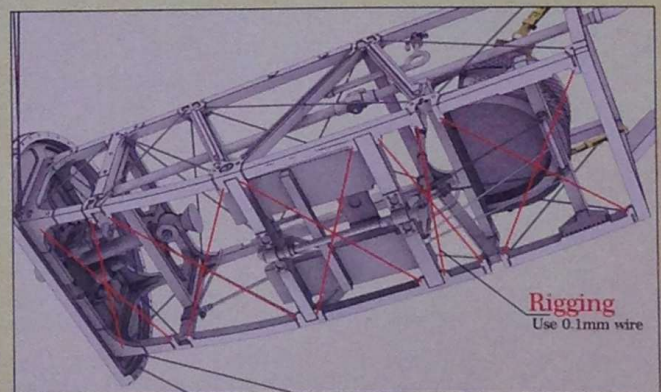

Step 19. Adding the rigging to the fuselage frame

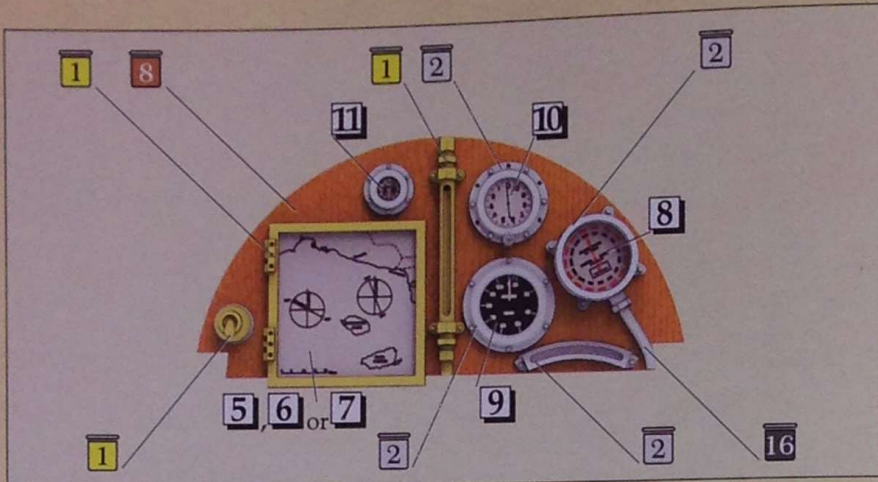
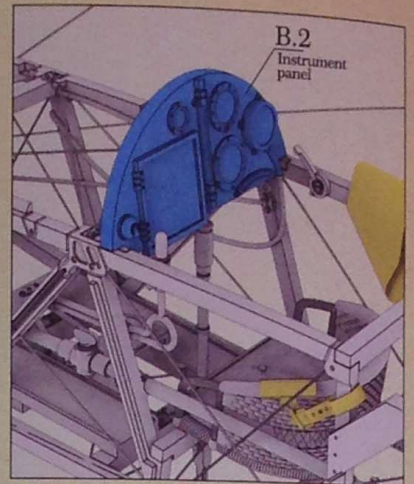
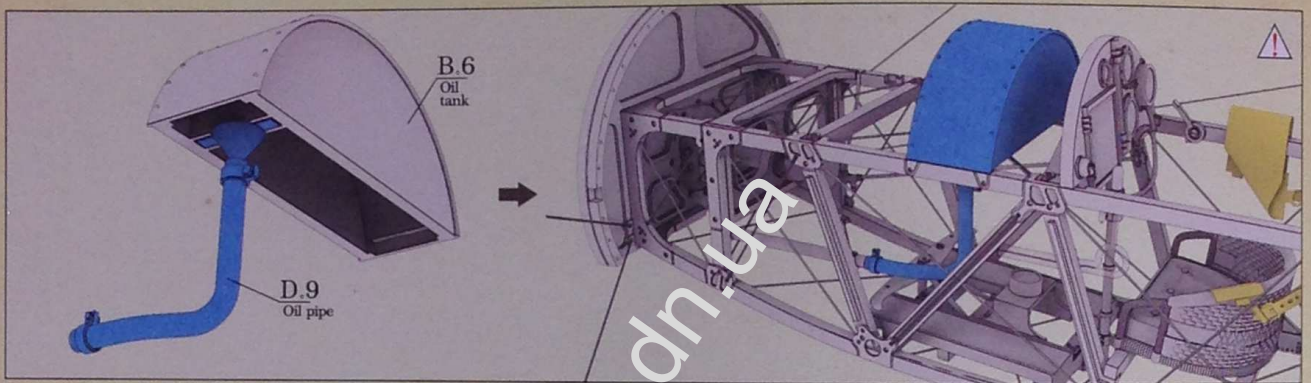

Fig.5. Decals and painting guide for the instrument panel



Step 20. Installing the instrument panel



Step 21. Installing the oil tank, only for markings page 18 (1:64)

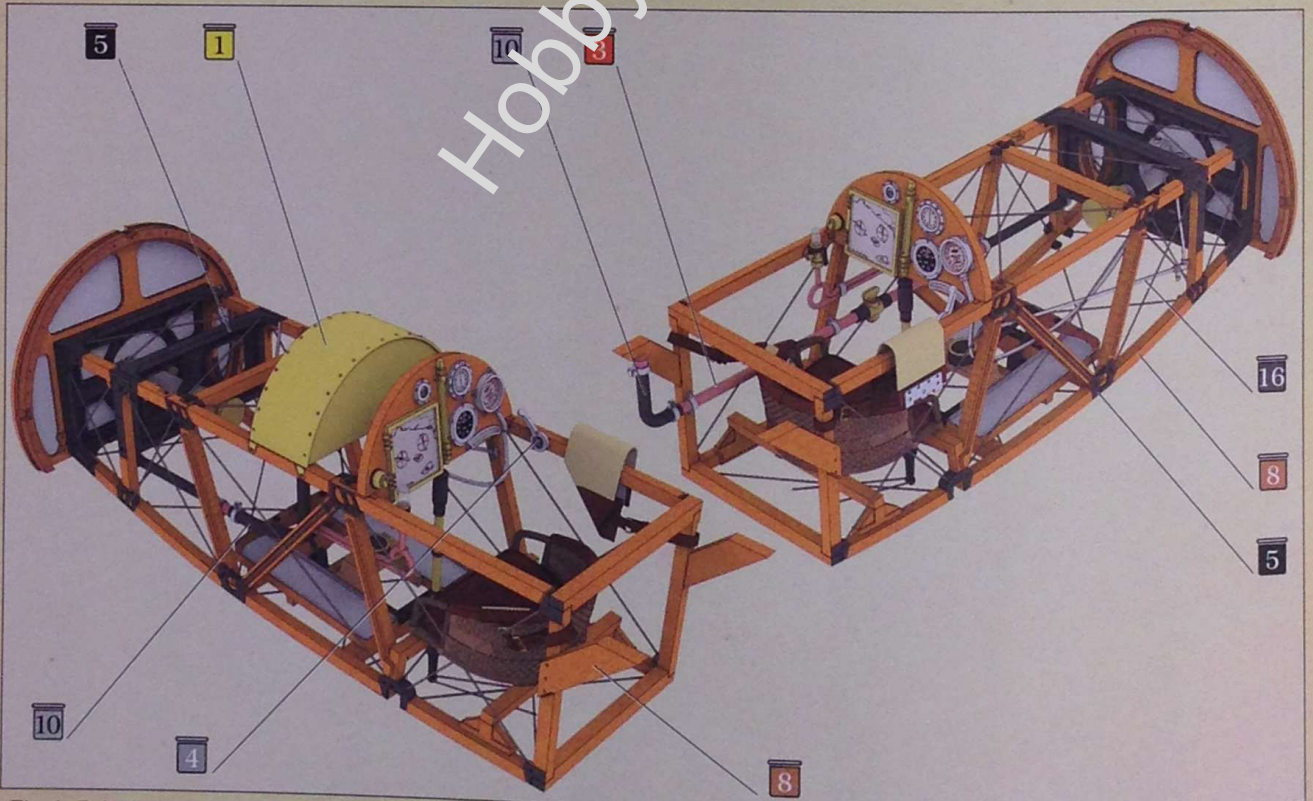
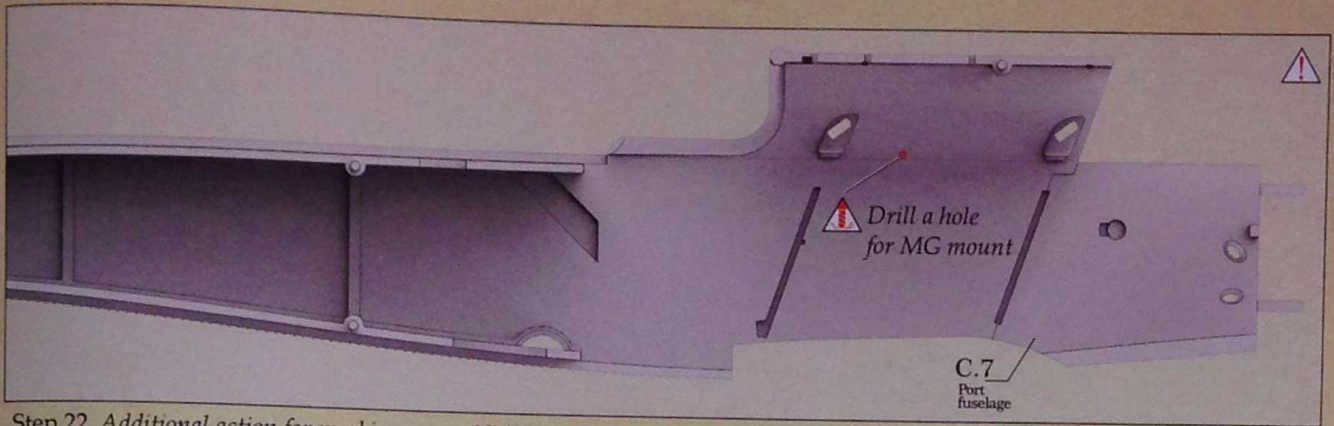
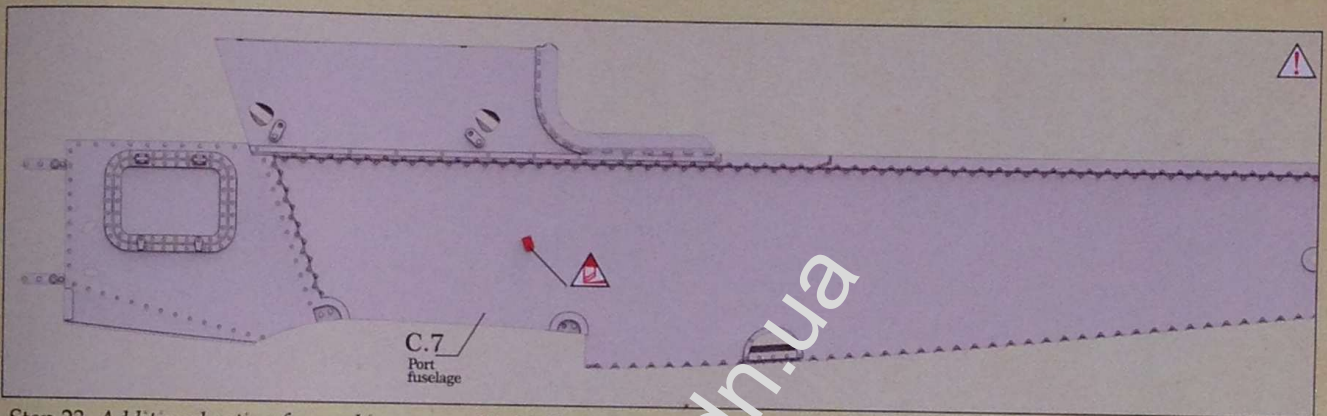

Fig.6. Painting guide for the cockpit section, both with oil tank and without it



Step 22. Additional action for markings page 19 (1611)



Step 23. Additional action for markings pages 18, 20-22 (1264 and 1455)

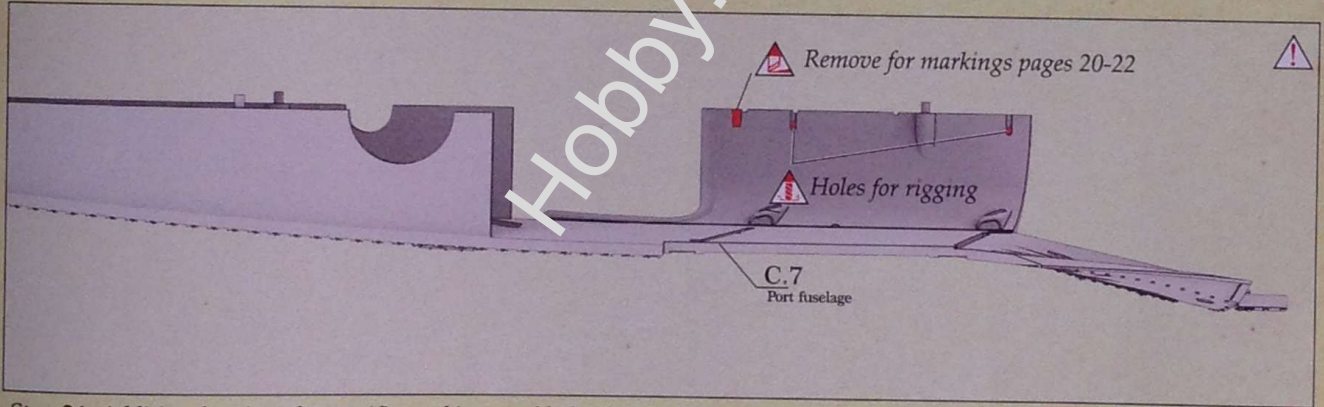

Step 24. Additional actions for specific markings and holes for rigging

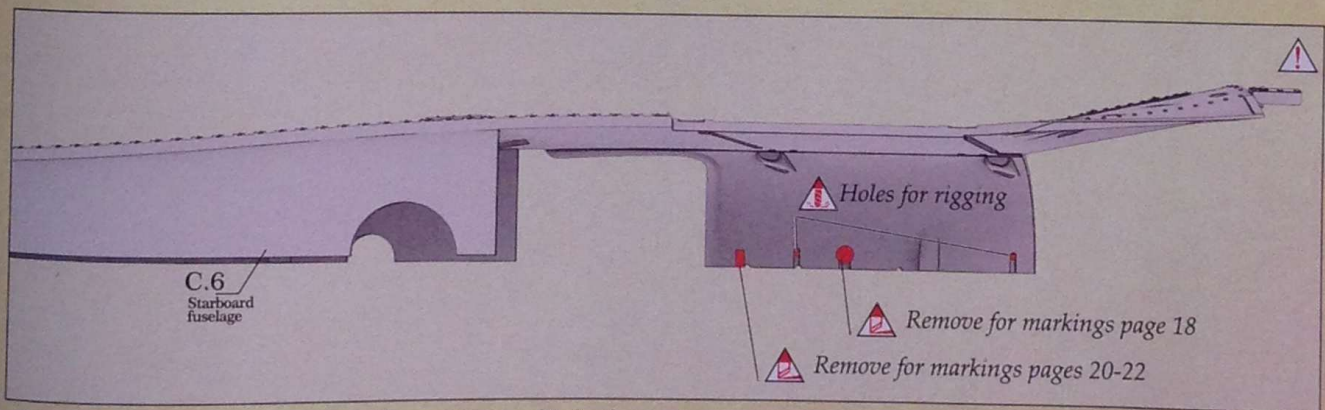

Step 25. Additional actions for specific markings and holes for rigging

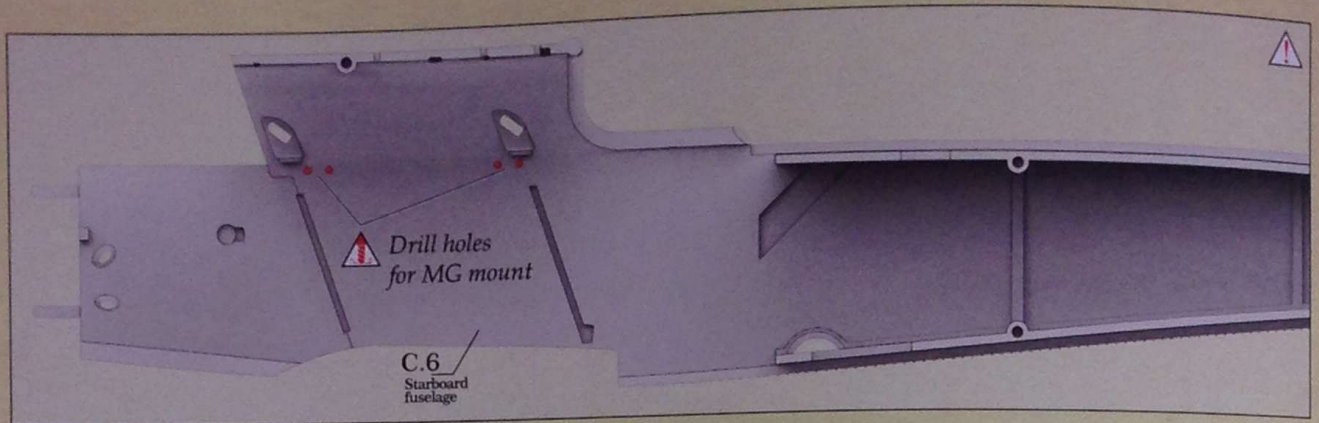

Step 26. Additional action **only** for markings page 18 (1264)

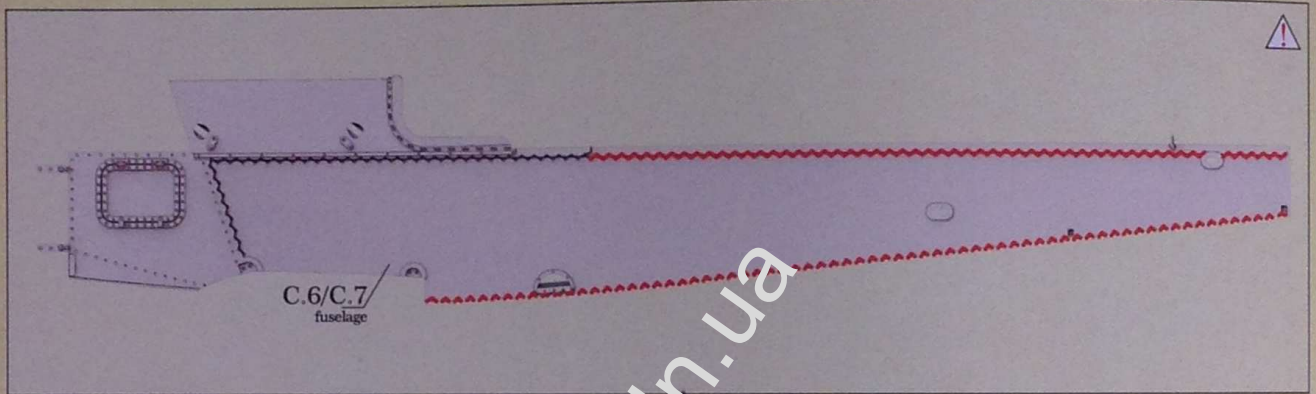

Step 27. Remove highlighted lacing **only** for markings pages 21-22 (1255)

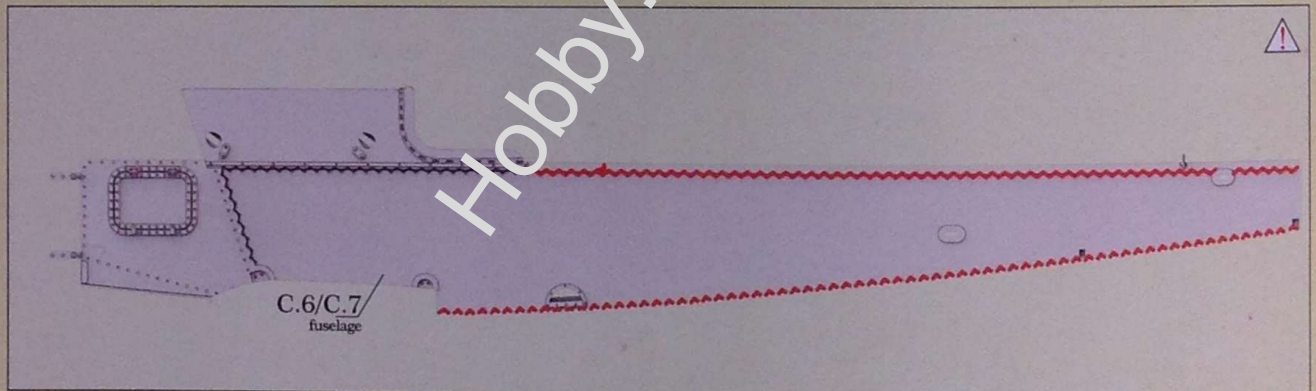

Step 28. Remove highlighted lacing **only** for markings page 18 (1264)

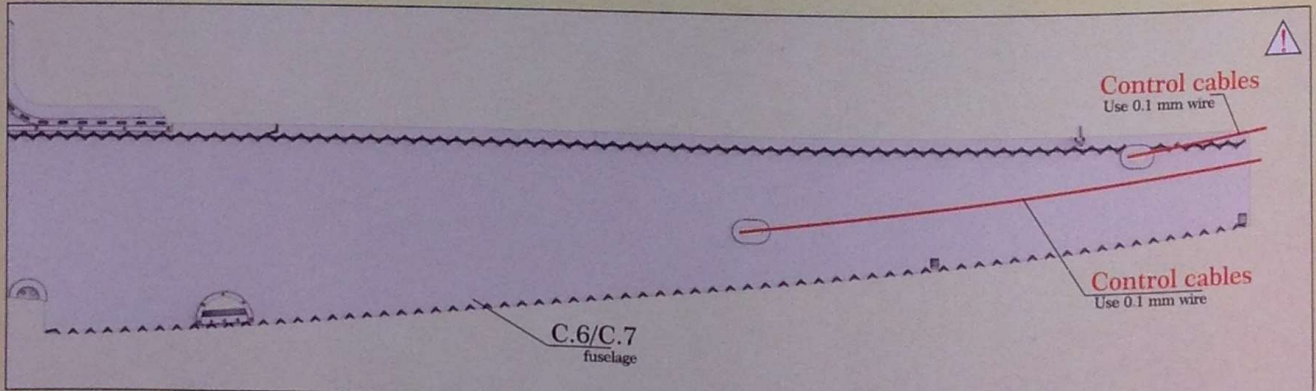

Step 29. Adding the control cables. Cables should be added to both parts C.6 and C.7

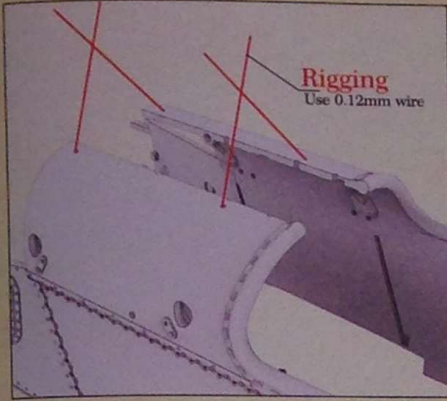

Step 30. Adding the rigging

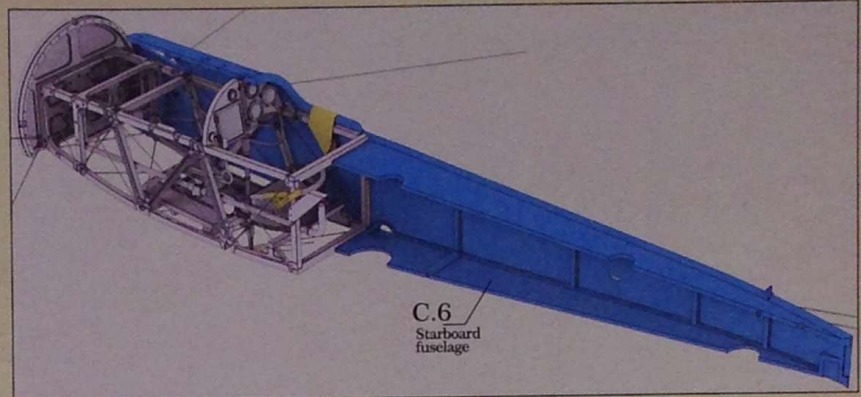

Step 31. Assembling the starboard fuselage piece and the cockpit

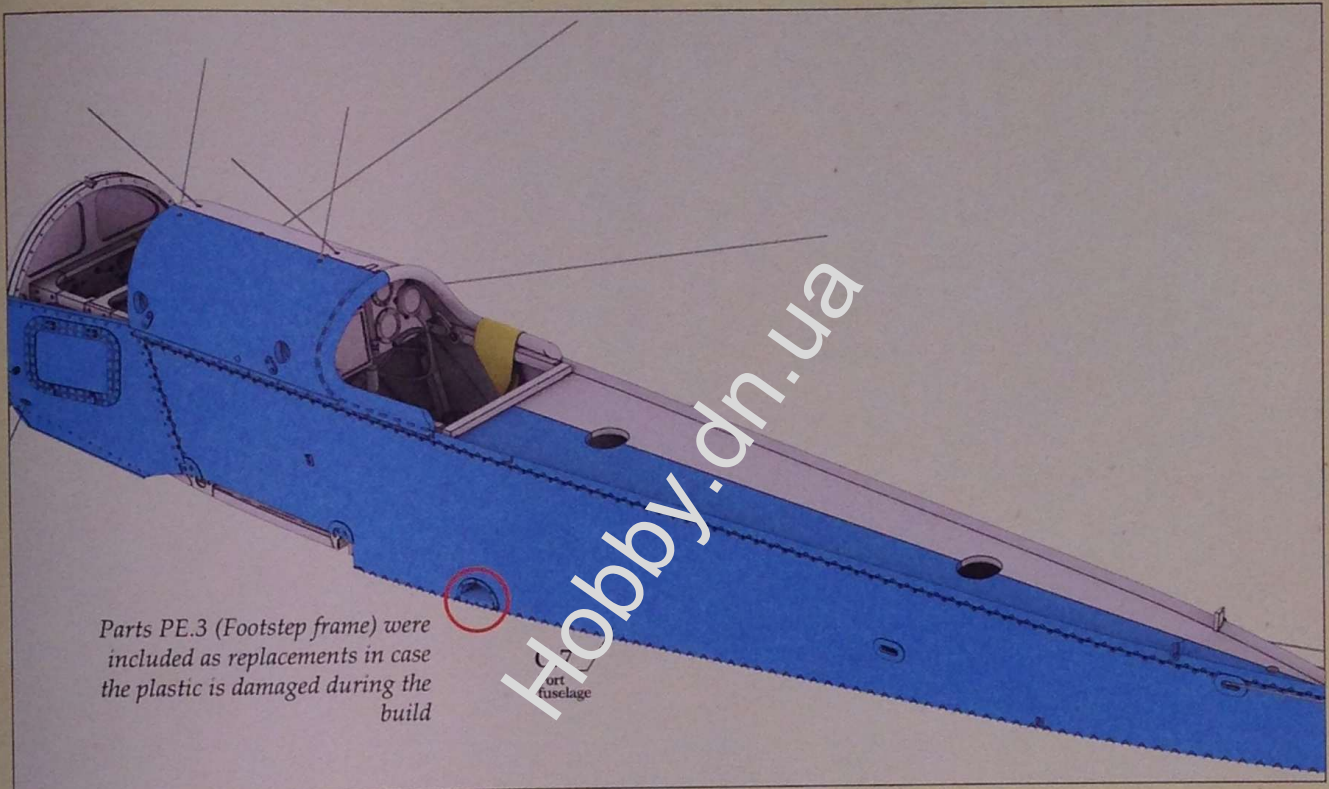

Parts PE.3 (Footstep frame) were included as replacements in case the plastic is damaged during the build

Step 32. Installing the port fuselage piece

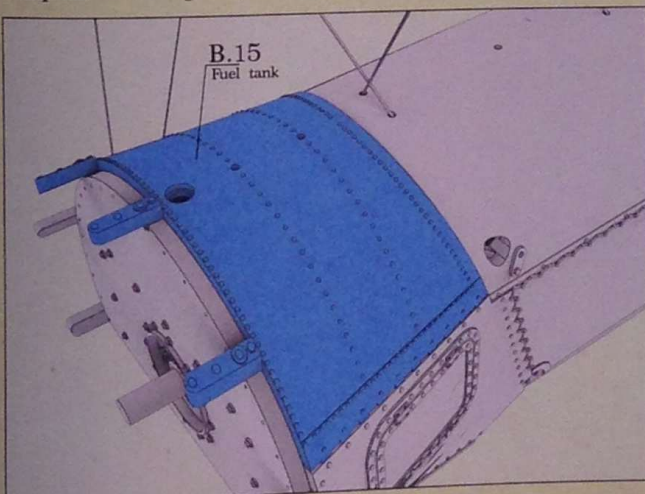

Step 33. Installing the fuel tank

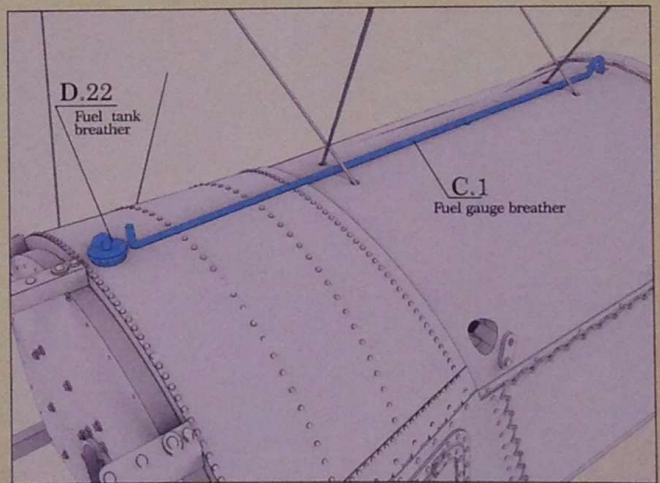

Step 34. Installing the fuel gauge breather and the fuel tank cap

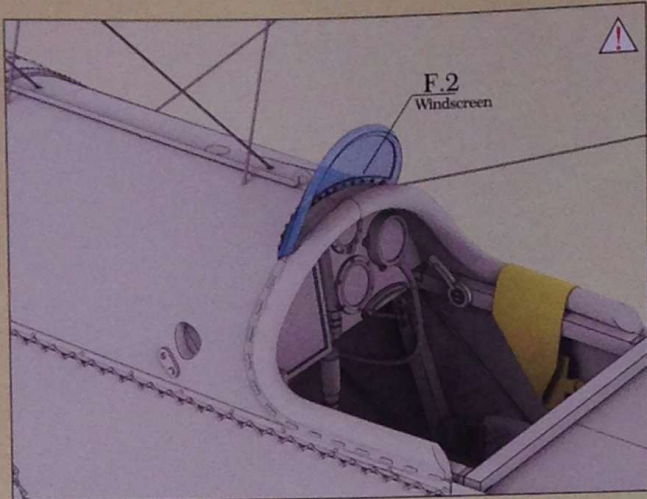

Step 35. Installation of the windscreen only for markings pages 20-22

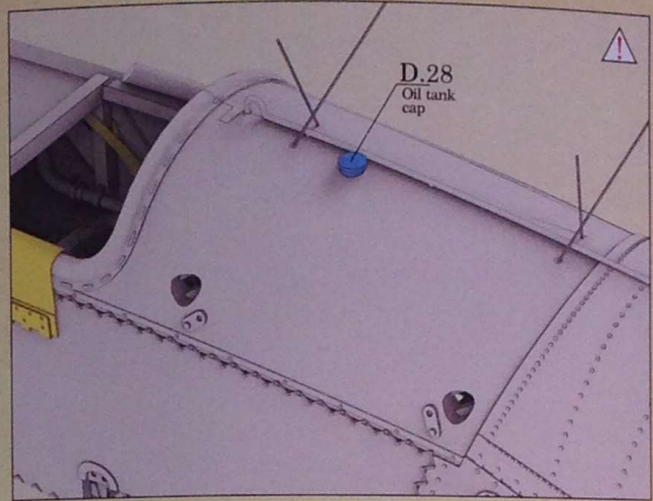

Step 36. Installation of the oil tank cap, only for markings page 18

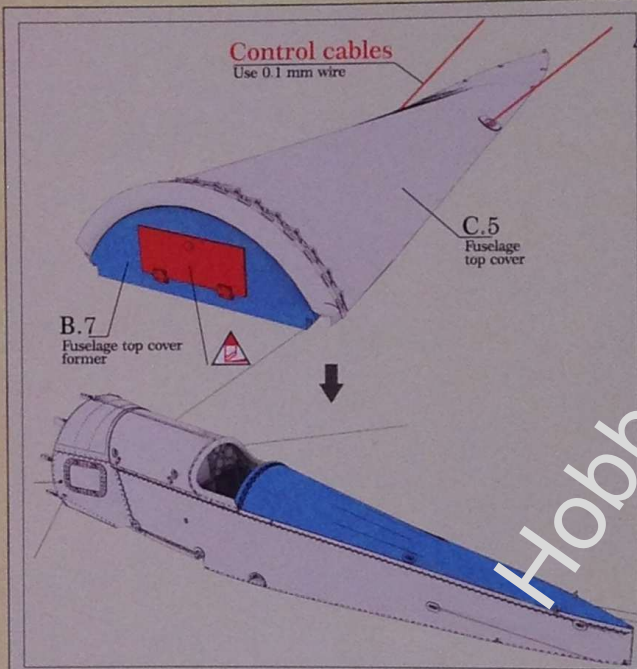

For markings page 18 (1264)

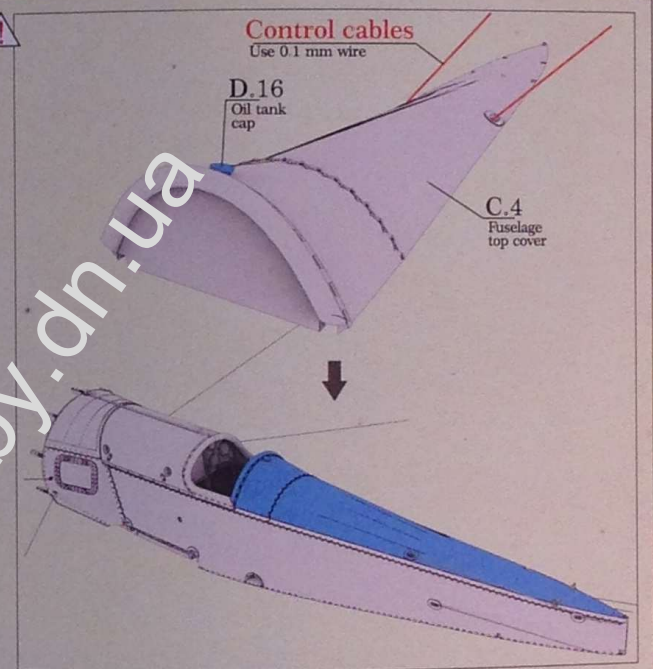

For markings pages 19-22 (1611 and 1255)

Step 37. Installing the top cover

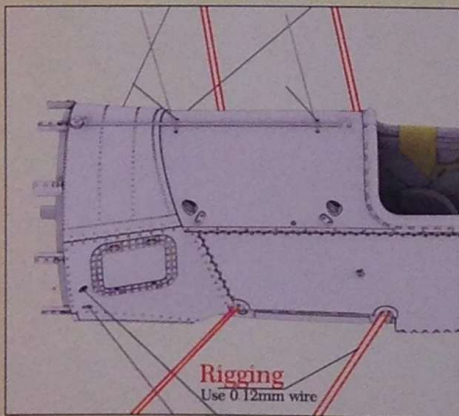

Step 38. Installing the flying wires

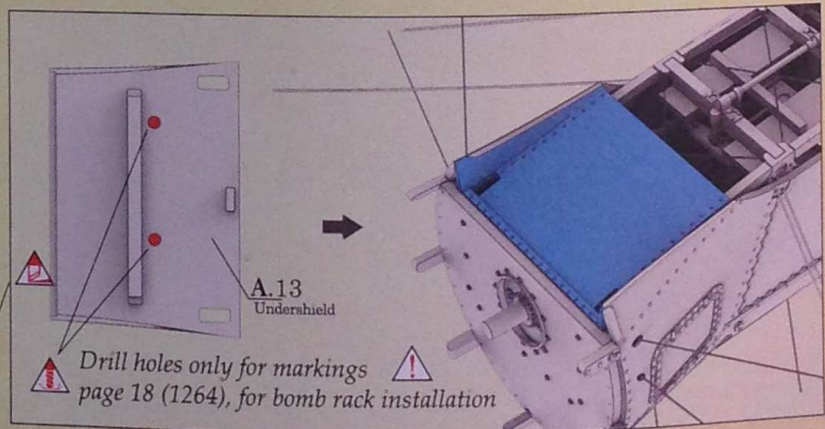

Step 39. Installation of the undershield

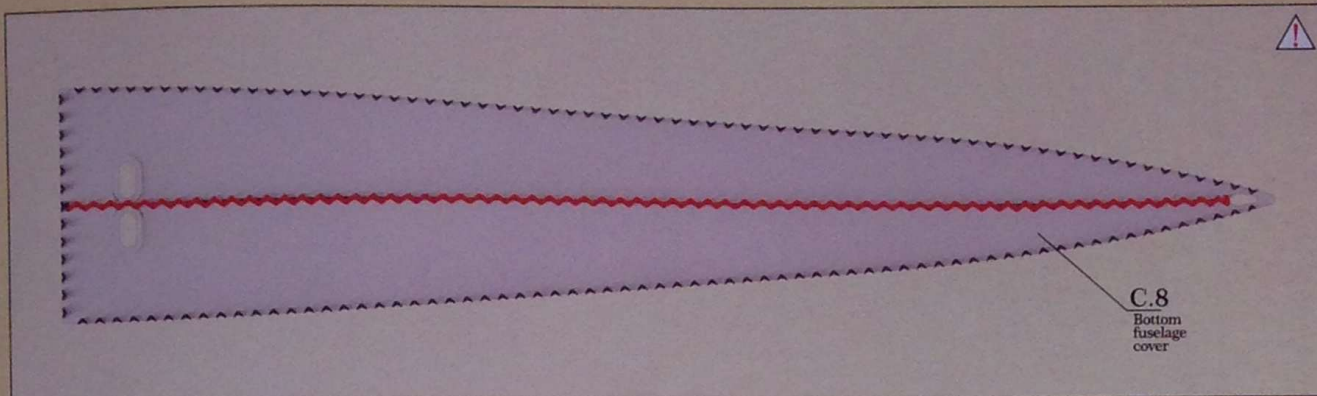

Step 40. Remove highlighted lacing only for markings page 19

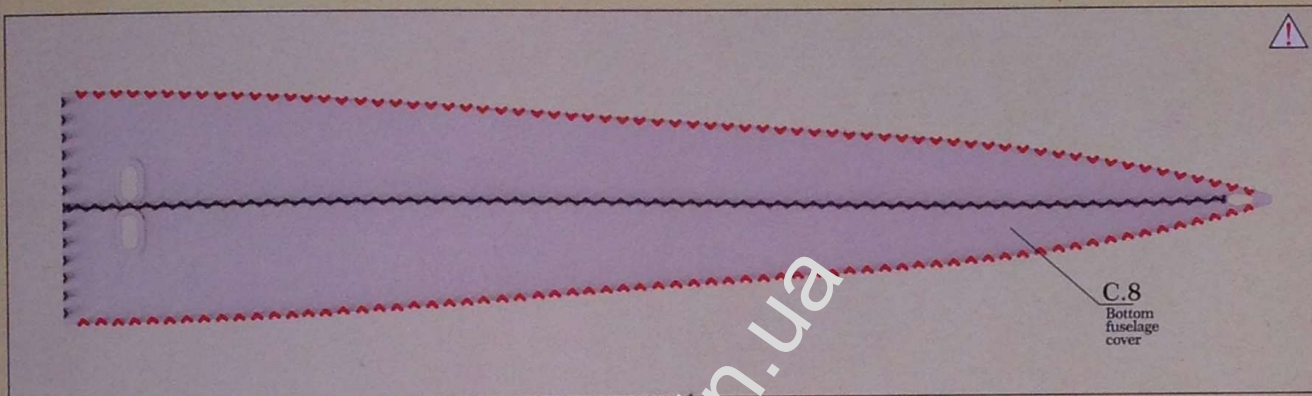

Step 41. Remove highlighted lacing only for markings pages 18, 20, 22

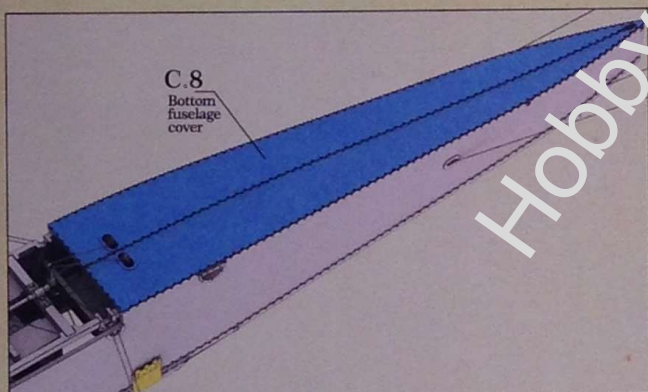

Step 42. Installing the bottom fuselage cover

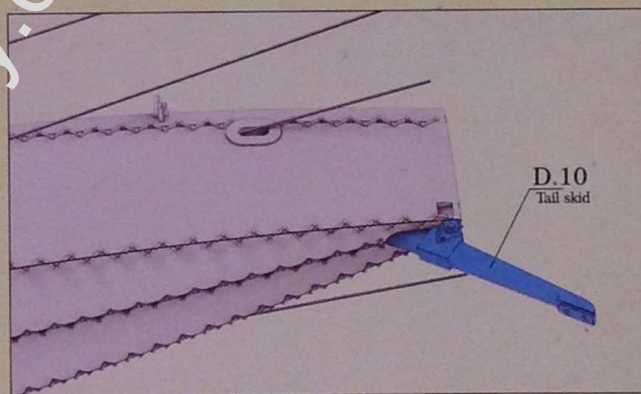

Step 43. Installation of the tail skid

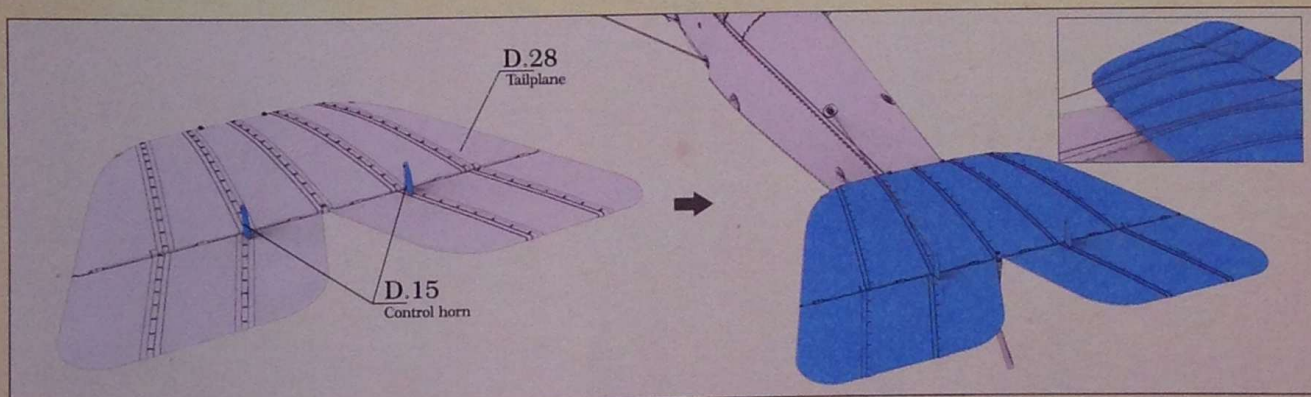

Step 44. Assembling and installing the tailplane and control horns

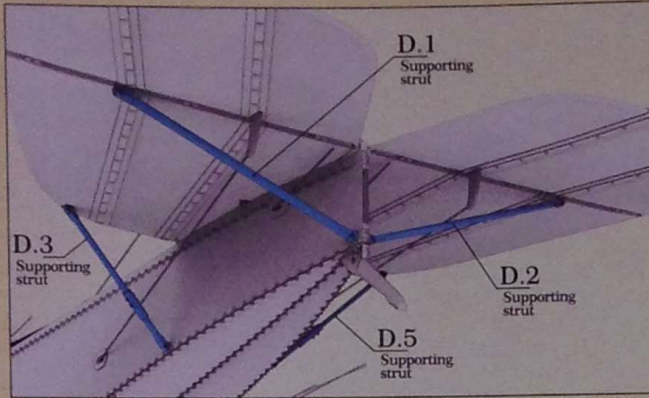

Step 45. Installing the tailplane support struts

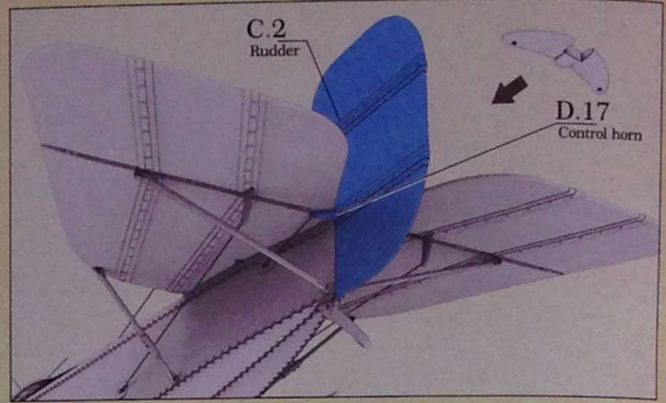

Step 46. Installing the rudder and control horn

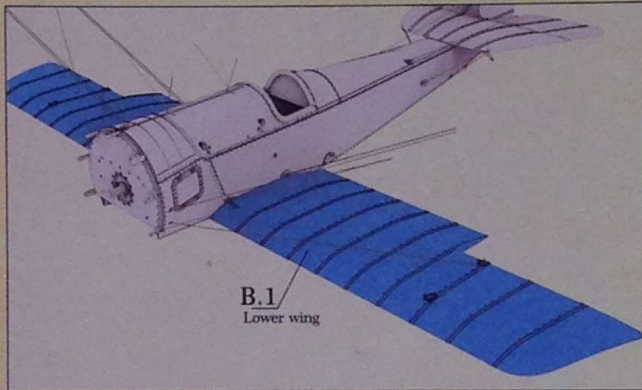

Step 47. Assembling the lower wing and cockpit

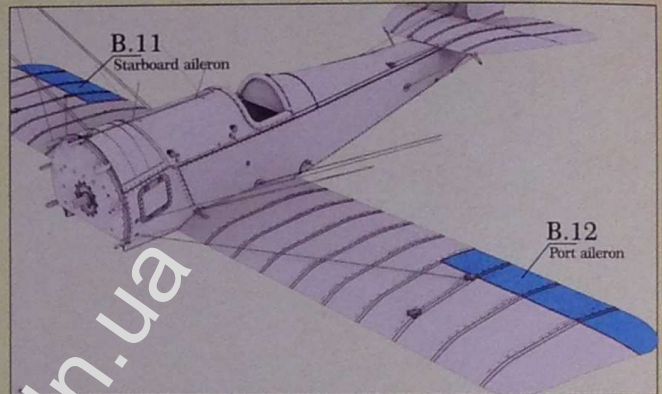

Step 48. Installing the ailerons

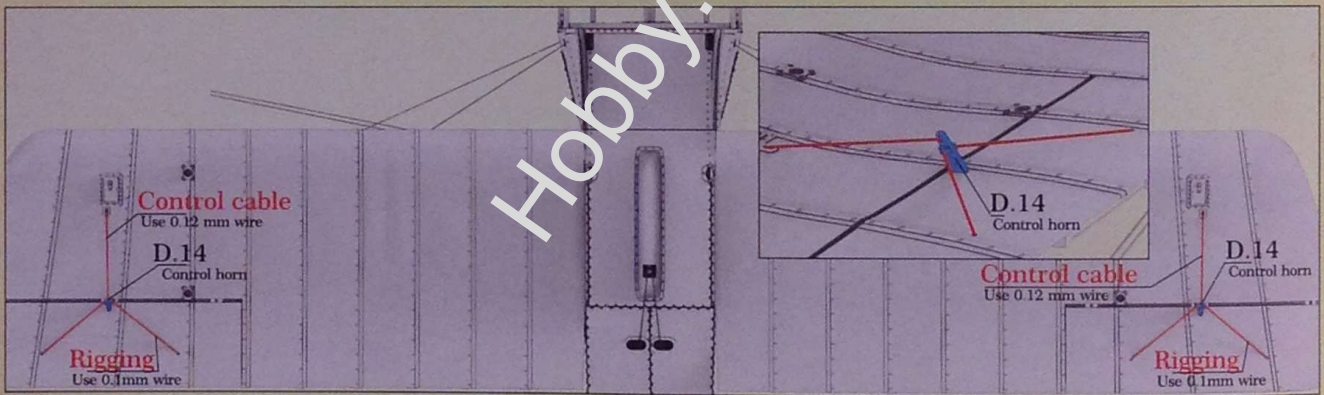

Step 49. Installing the control horns, control cables and additional rigging

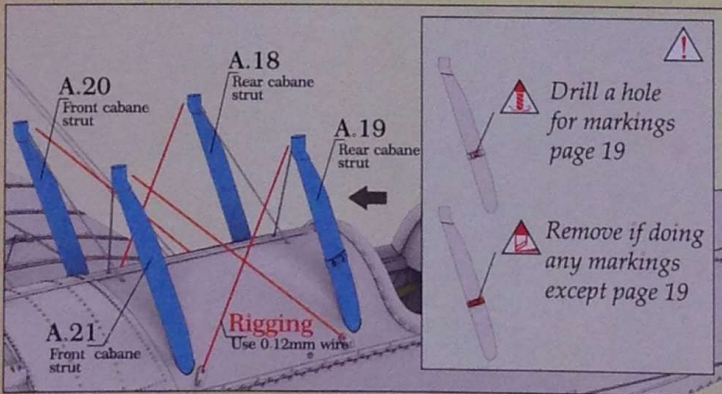

Step 50. Installing the cabane struts

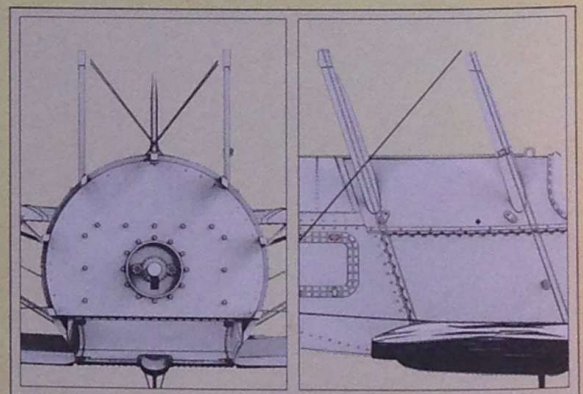
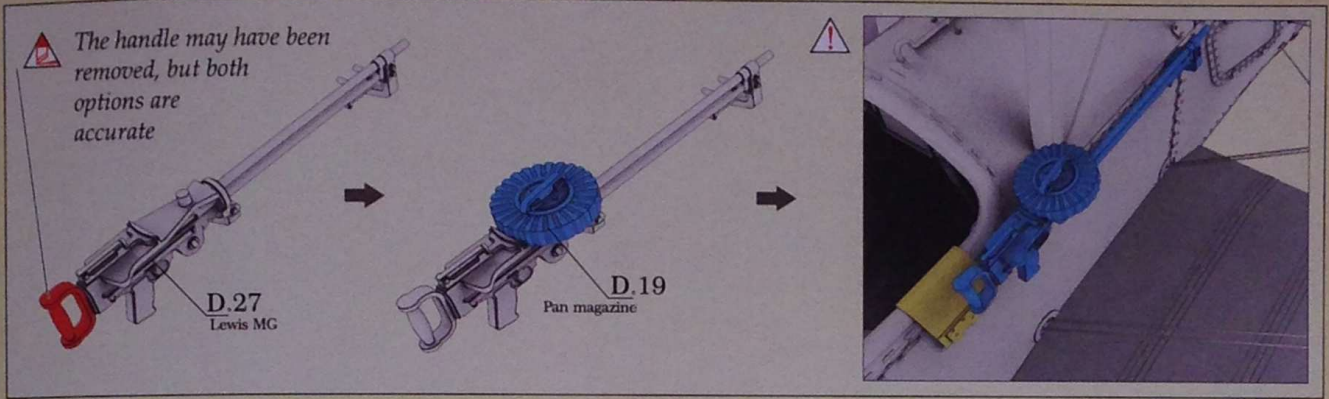
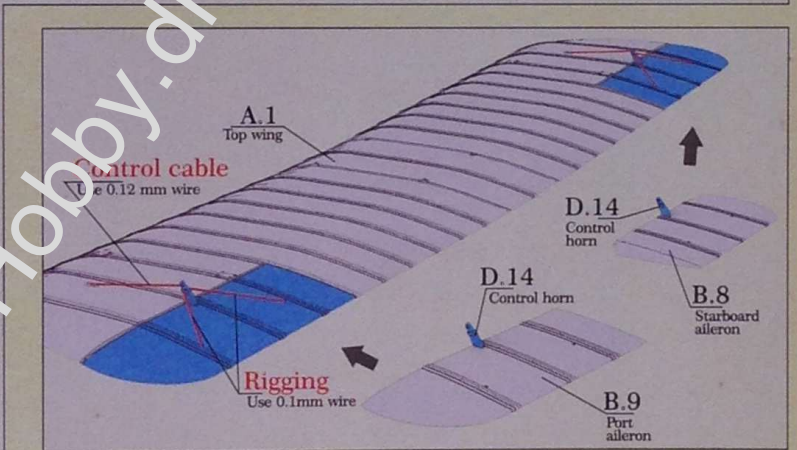
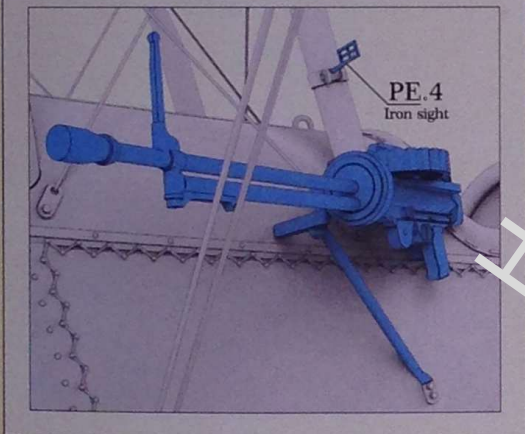
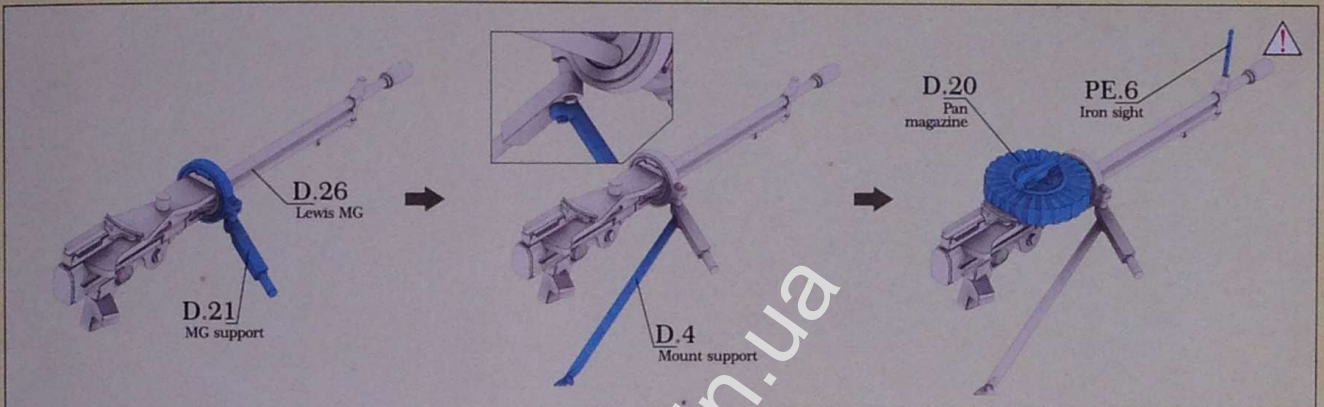

Fig. 7. Check the cabane struts alignment and angle



Step 51. Lewis MG assembly, only for markings page 18



Step 52. Lewis MG assembly, only for markings page 19

Step 53. Assembling the top wing

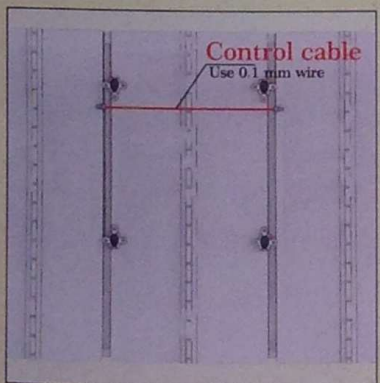

Step 54. Adding the control cable to the top wing

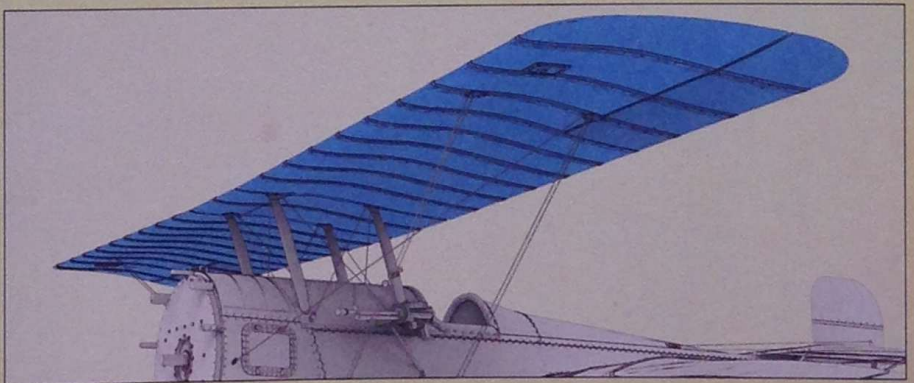

Step 55. Installing the upper wing

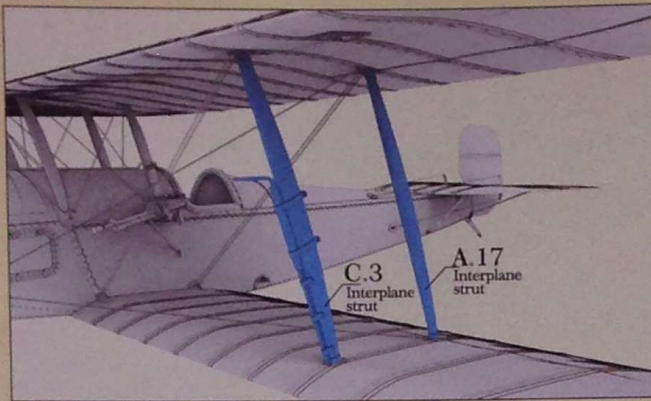

Step 56. Installation of the port interplane struts

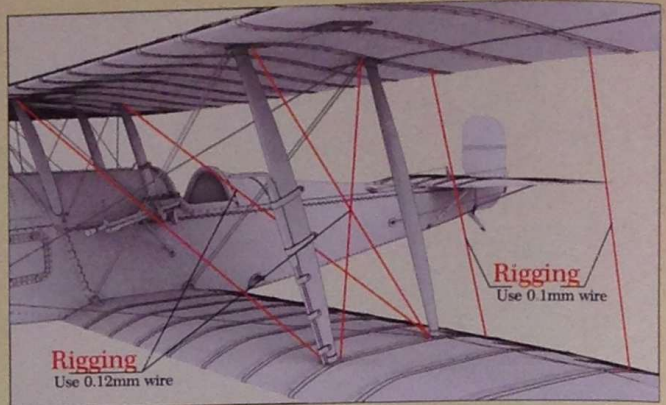

Step 57. Installation of the starboard flying and landing wires

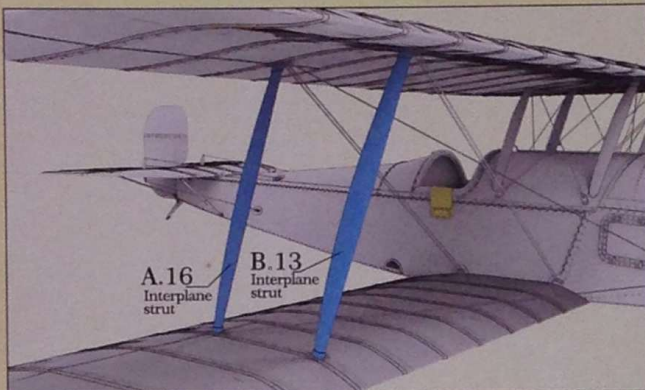

Step 58. Installation of the starboard interplane struts

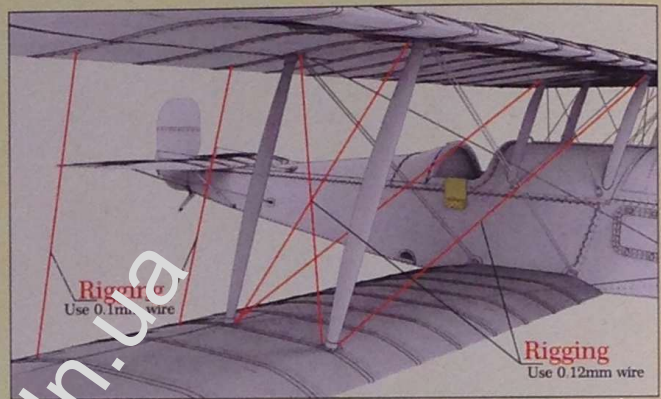

Step 59. Installation of the port flying and landing wires

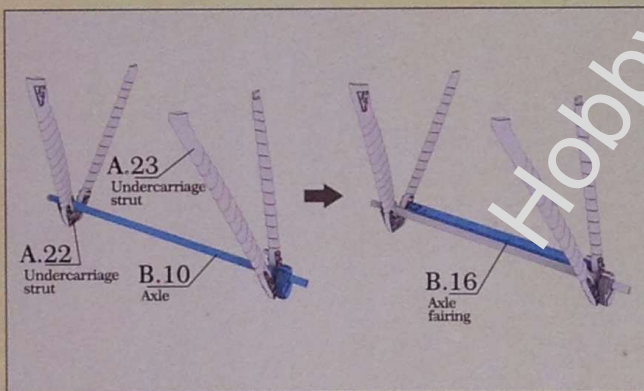

Step 60. Assembling the undercarriage struts and axle

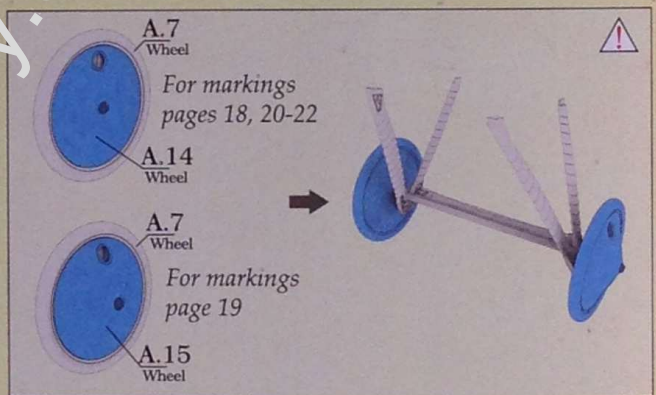

Step 61. Assembling and installing the wheels

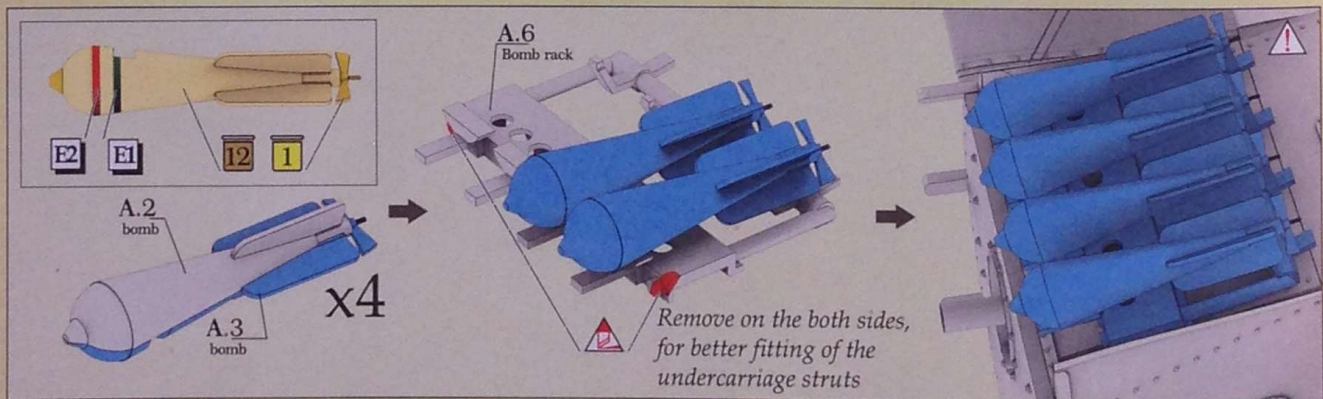

Step 62. Assembling and installing the bombs. Only for markings page 18

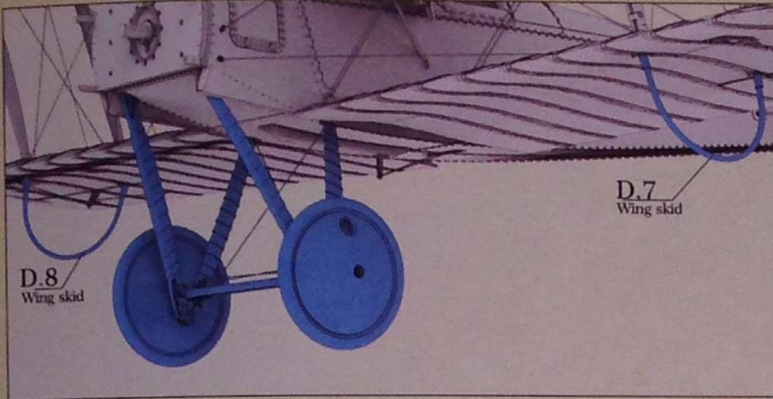

Step 63. Installing the undercarriage and wing skids

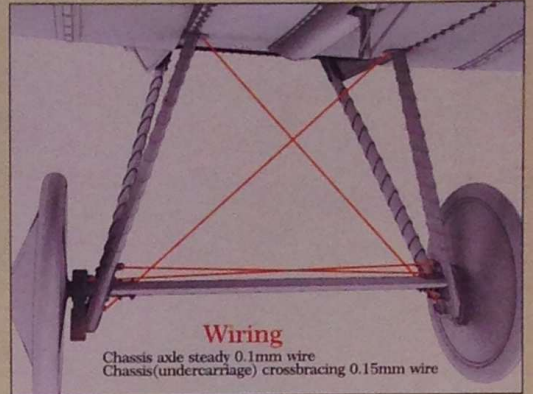

Step 64. Adding the wire bracings

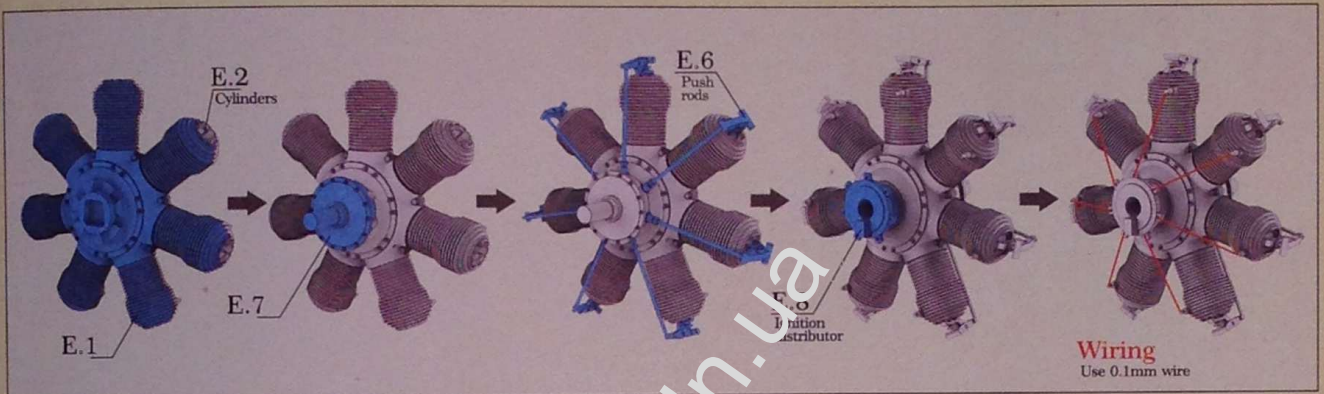

Step 65. Assembling the Gnome Lambda aero engine

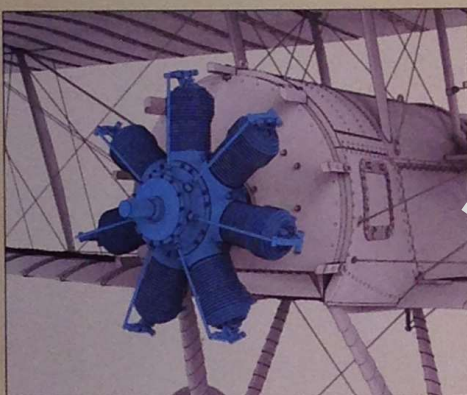

Step 66. Installing the Gnome Lambda engine

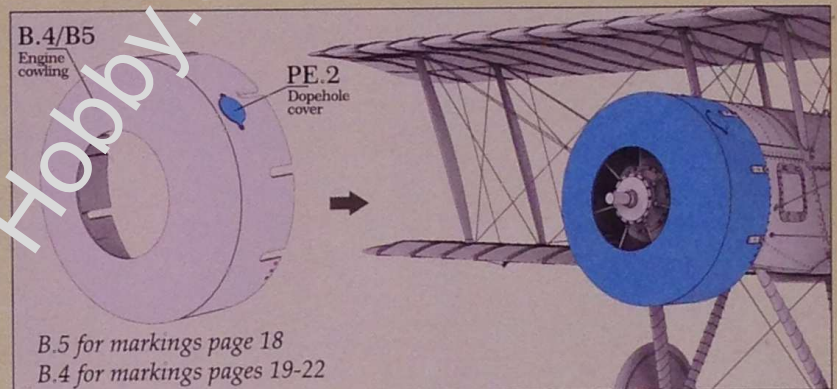

Step 67. Assembling and installing the engine cowl



Step 68. Installing the airscrew

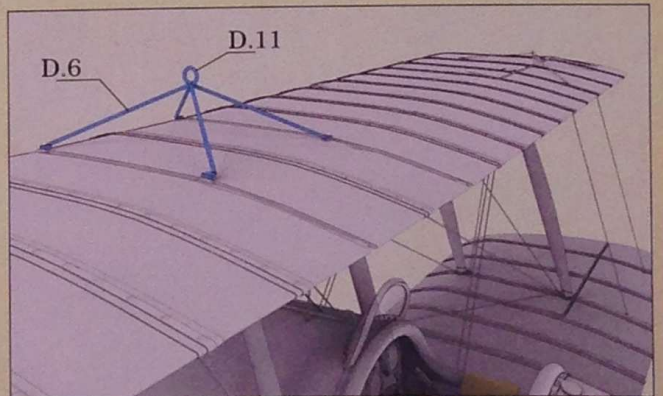

Step 69. Installing the lifting eye, only for markings page 20

www.bristolscout.wordpress.com - for colour reference

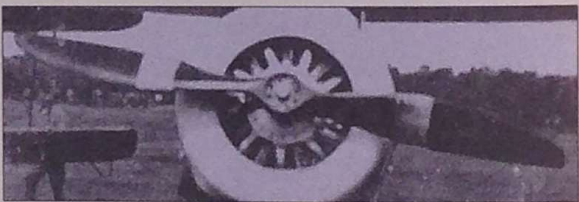
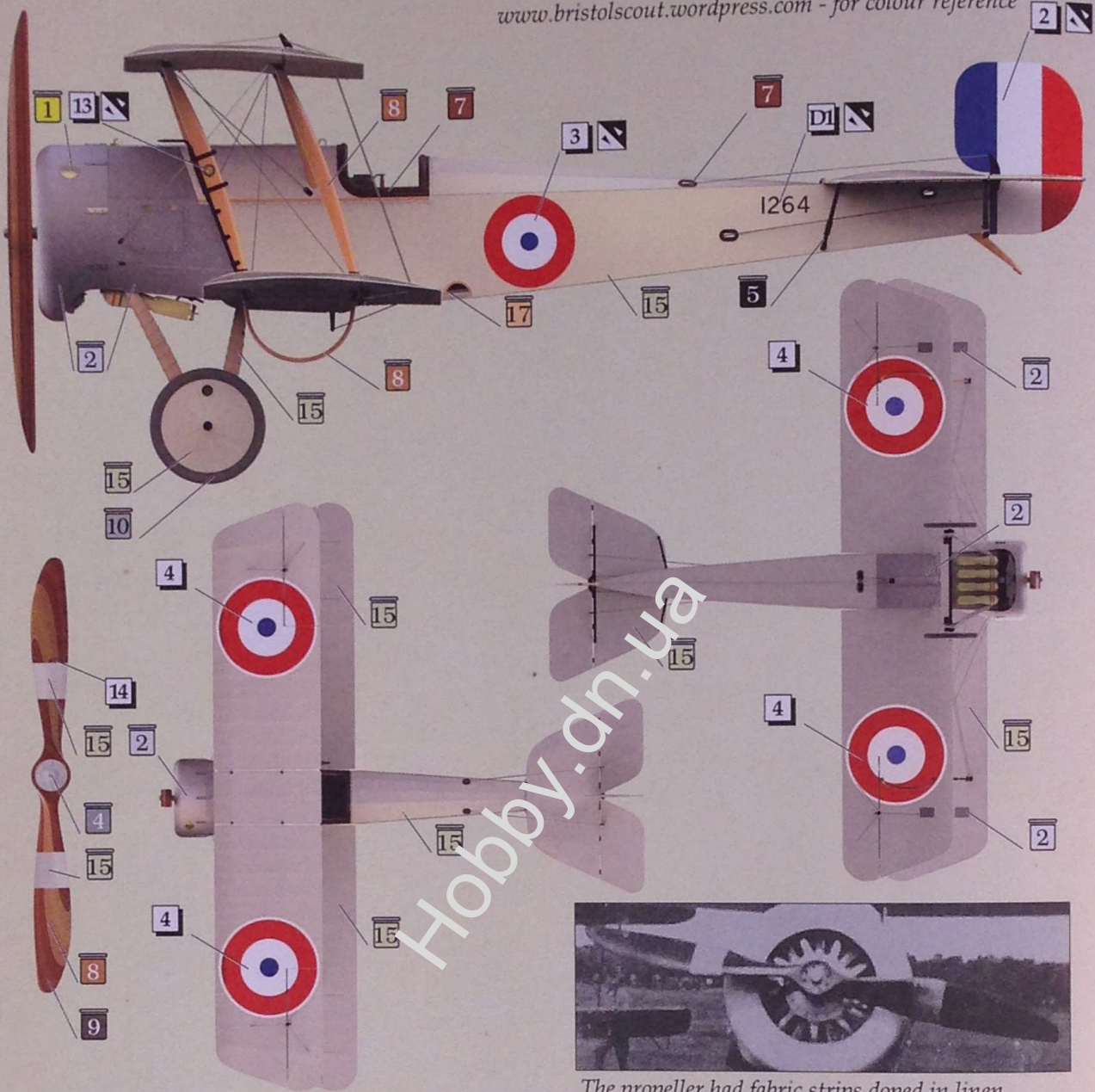

The propeller had fabric strips doped in linen

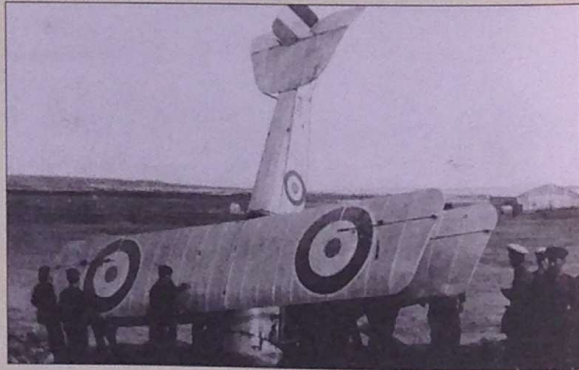

www.bristolscout.wordpress.com - for colour reference

Illustration 1.
 Scout C 1264, RNAS
 Francis Donald Holden Bremner served in the Eastern Mediterranean with No. 2 Wing RNAS at Imbros and Thassos.
 Later on, Sub.Lt. Bremner replaced the Gnome engine with an 80 hp. Le Rhone.

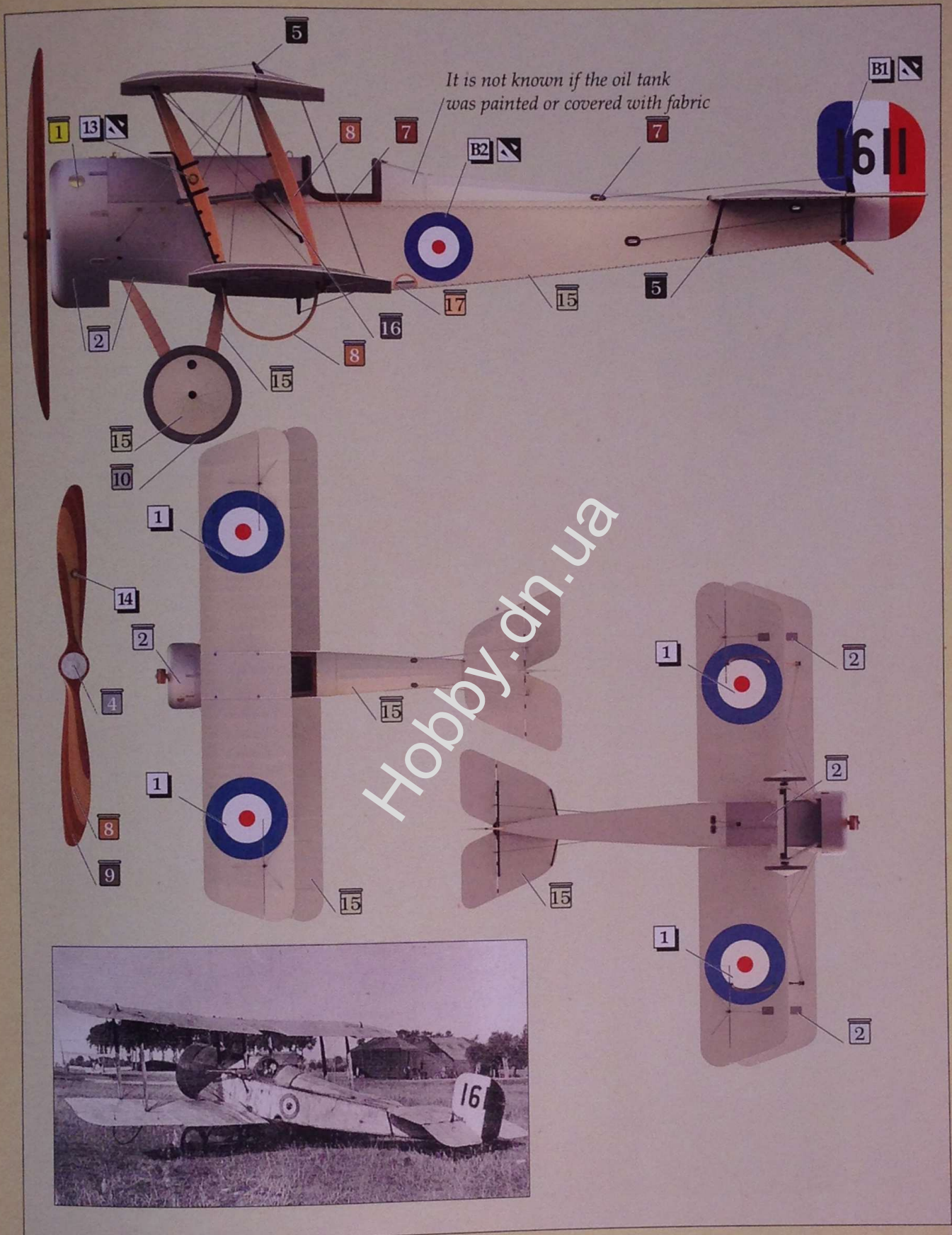

Illustration 2.

Scout C 1611, RFC

Lanoe George Hawker got the first VC for aerial combat in this machine armed with a single Lewis Gun on the port side firing just clear of the propeller arc and slightly downwards

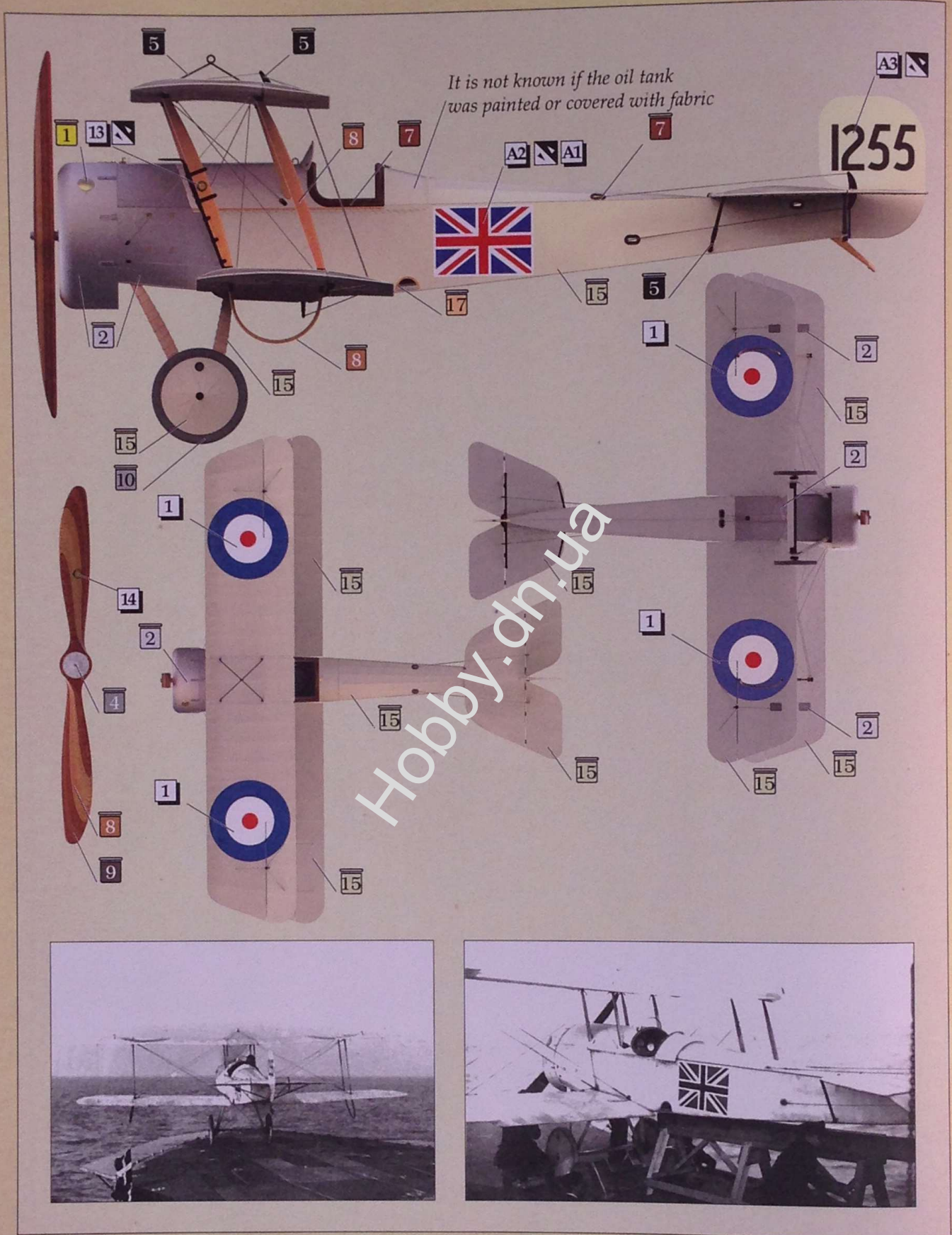

Illustration 3.

Scout C 1255, RNAS

The first aircraft to take off from a moving ship (HMS Vindex) in November 1915. The serial number was on the rudder, with Union flags on the fuselage sides and (probably) French cockades on the wings, probably top and bottom

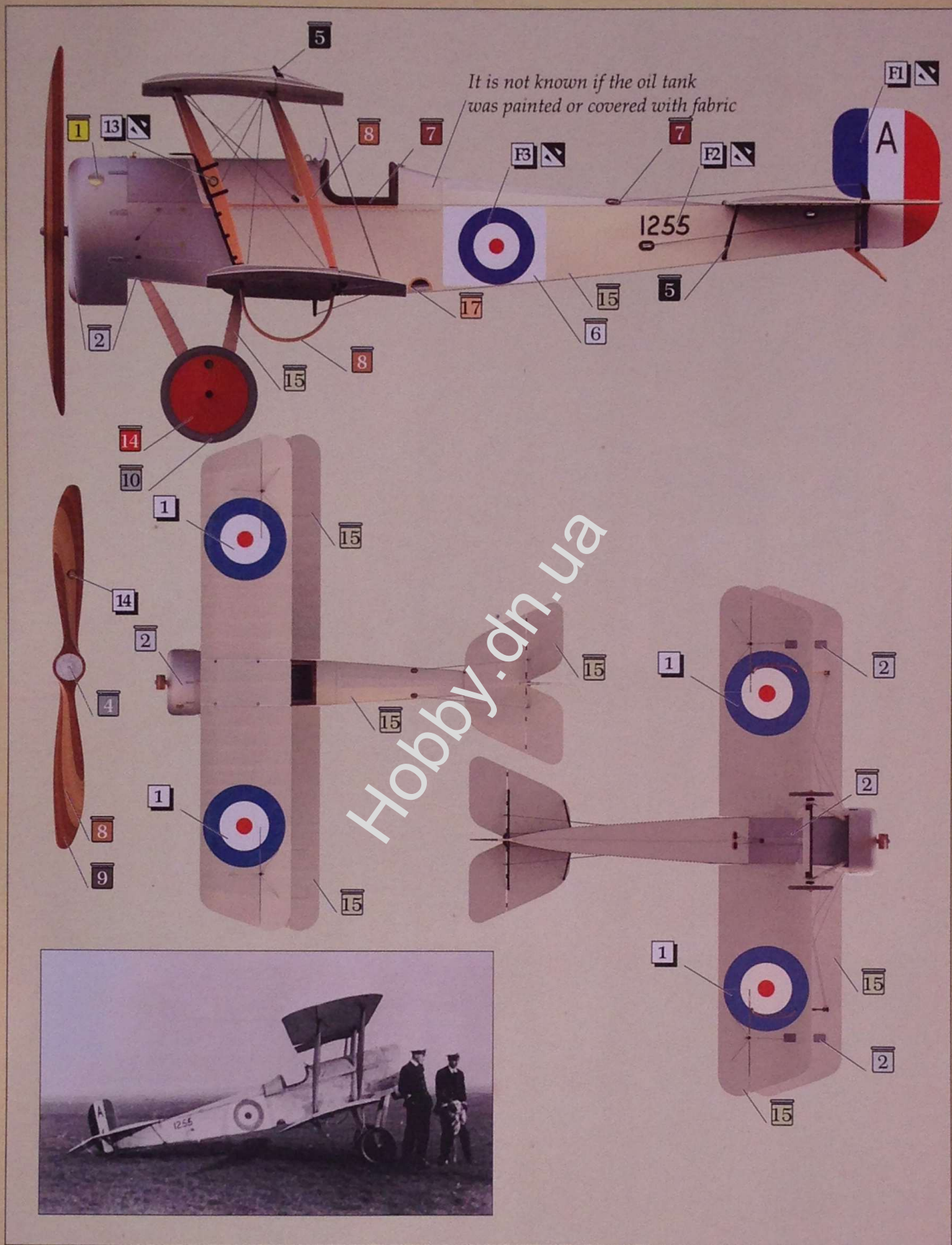

Illustration 4.

Scout C 1255, RNAS

After the historic flight from HMS Vindex, this aircraft joined No. 4 Wing at Eastchurch, March 23 1916.

A later photo shows vertical colours on the rudder with the letter A, the serial number on the fuselage side, and the Union Flag overpainted with a British roundel.

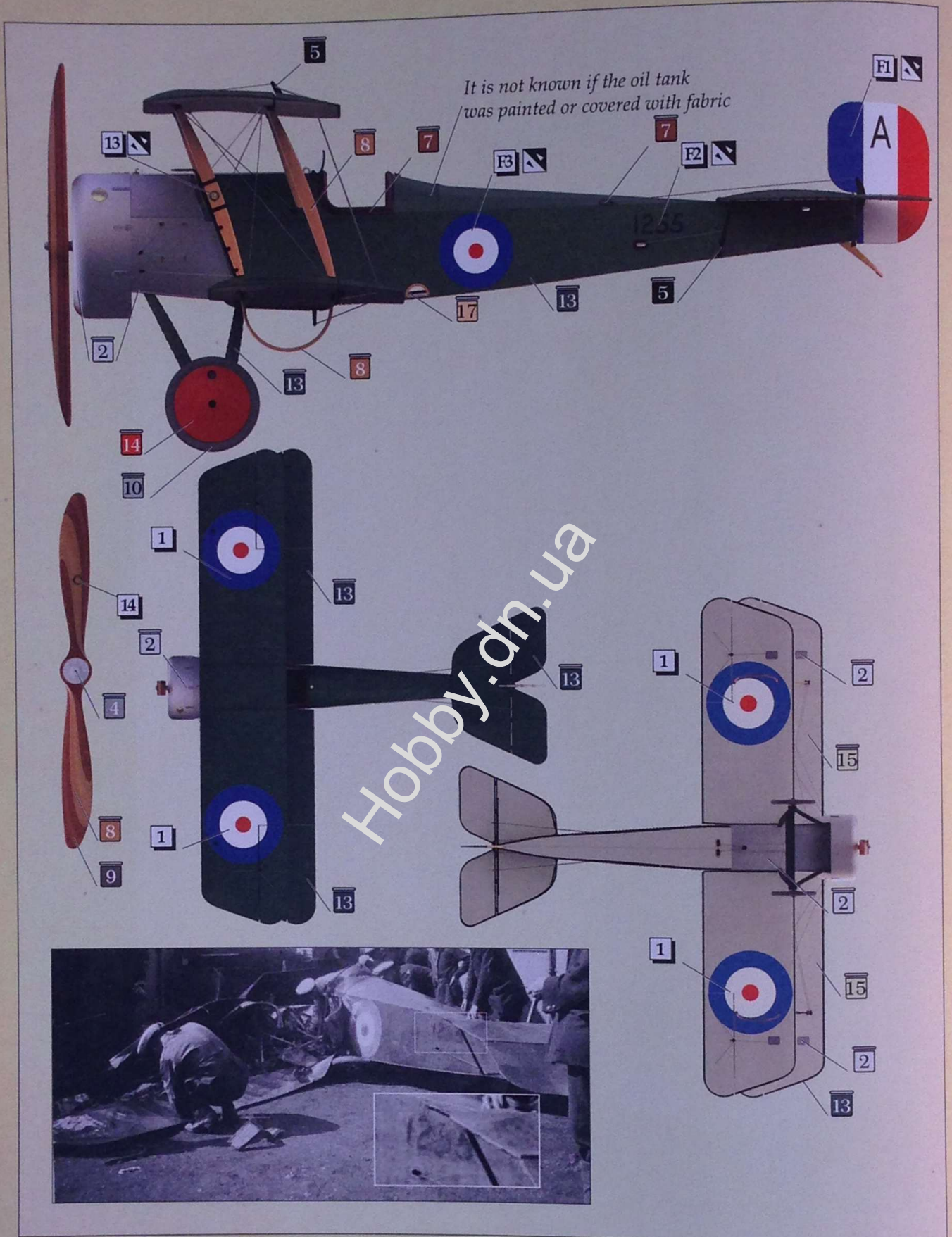

Illustration 5.
 Scout C 1255, RNAS
 Before the crash on Aug. 31 1916 it joined Eastchurch Bomb Flight, where the PC10 was applied.

CSM team would like to thank:

David Bremner - United Kingdom
Daniel Arbon - United Kingdom
Rupert Wasey - United Kingdom
Brandon Darnell - USA

for all your help in this project

Hobby.dh.ua

CSM SIA
Cesvaines 4, LV-1073
Riga, Latvia



Visit our website
www.copperstatemodels.com