

DW 72010



# P-63A Kingcobra Racer

1/72 SCALE MODEL CONSTRUCTION KIT

Ready to assemble scale models kit.

Contains part for one model.

Model length: 104 mm

Wingspan: 96 mm

Plastic parts: 76

Photoetched parts: 19

Numerous surplus P-63s ended up on the air racing circuit in the immediate postwar era.

Charles Tucker purchased a couple of P-63s from the disposal facility at Kingman, Arizona just after the war. He entered one of them (civilian register N62995) in the 1946 Thompson Trophy race. He had clipped off the wing in an attempt to improve the speed, reducing the span to 25 feet 9 inches. The second one (44-4126 (XN63231) was intended for the 1946 Bendix cross country race. It was initially fitted with two wingtip drop tanks. In 1947, the drop tanks were removed and the wings were clipped to 28 feet 6 inches.

## PARTS OF THE MODEL

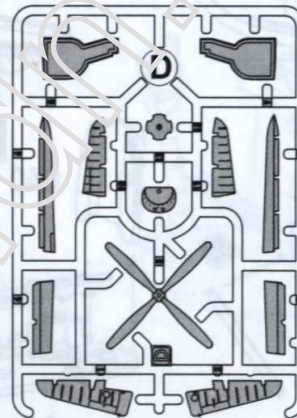
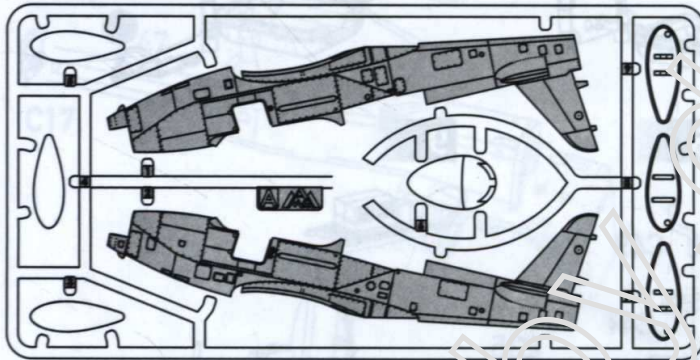

Resin

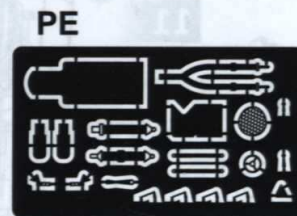
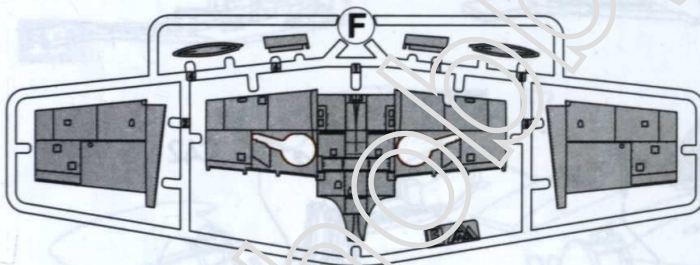
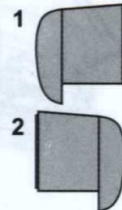

PE



Mask

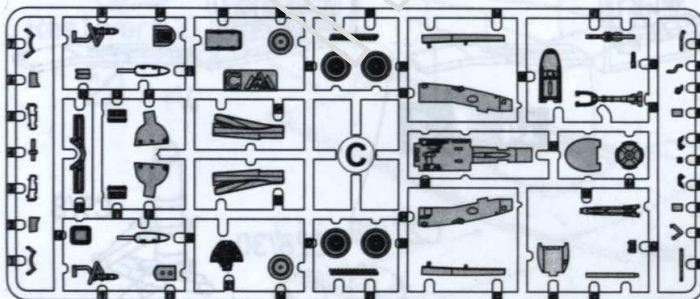

Decal





# ASSEMBLY INSTRUCTION

010570

1 x2



2

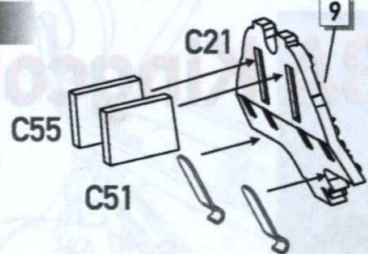

3

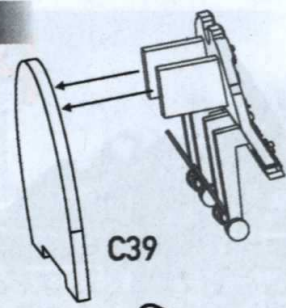

4

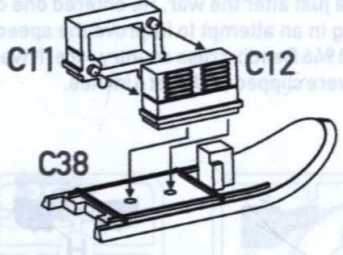

5



6



7

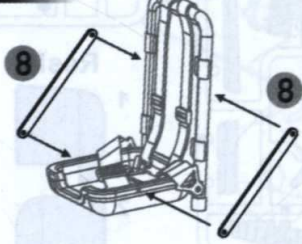

8

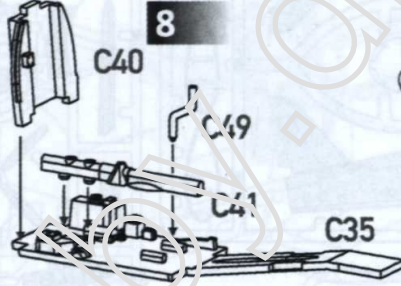

9

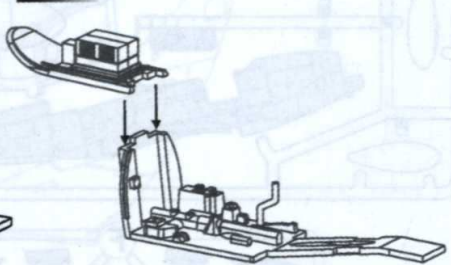

10

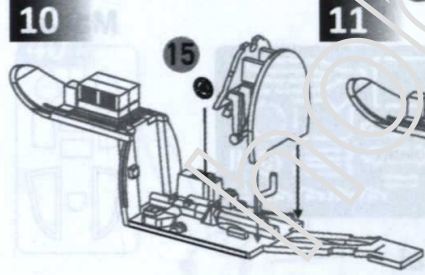

11

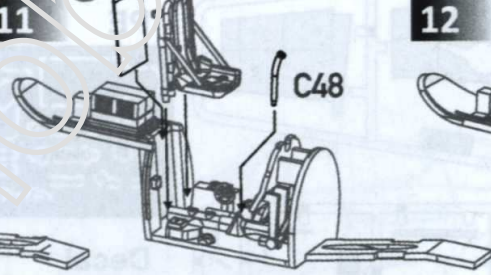

12

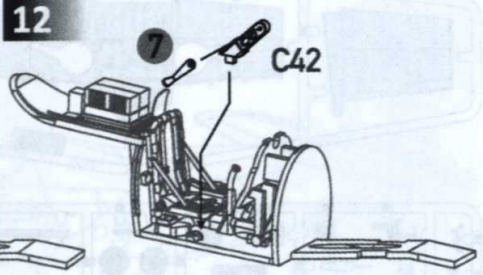

13

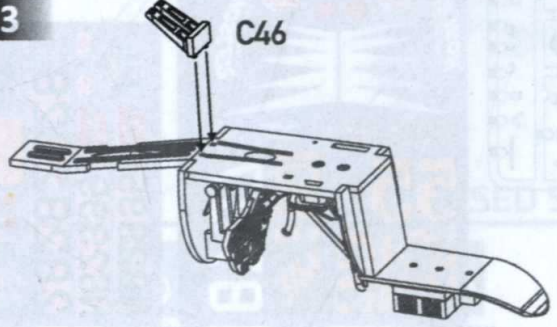

14 x2

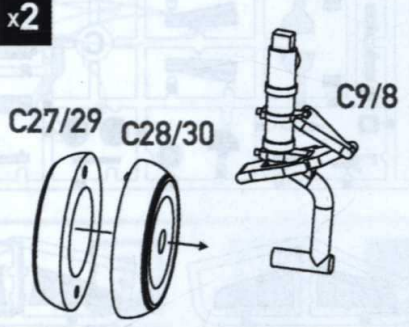



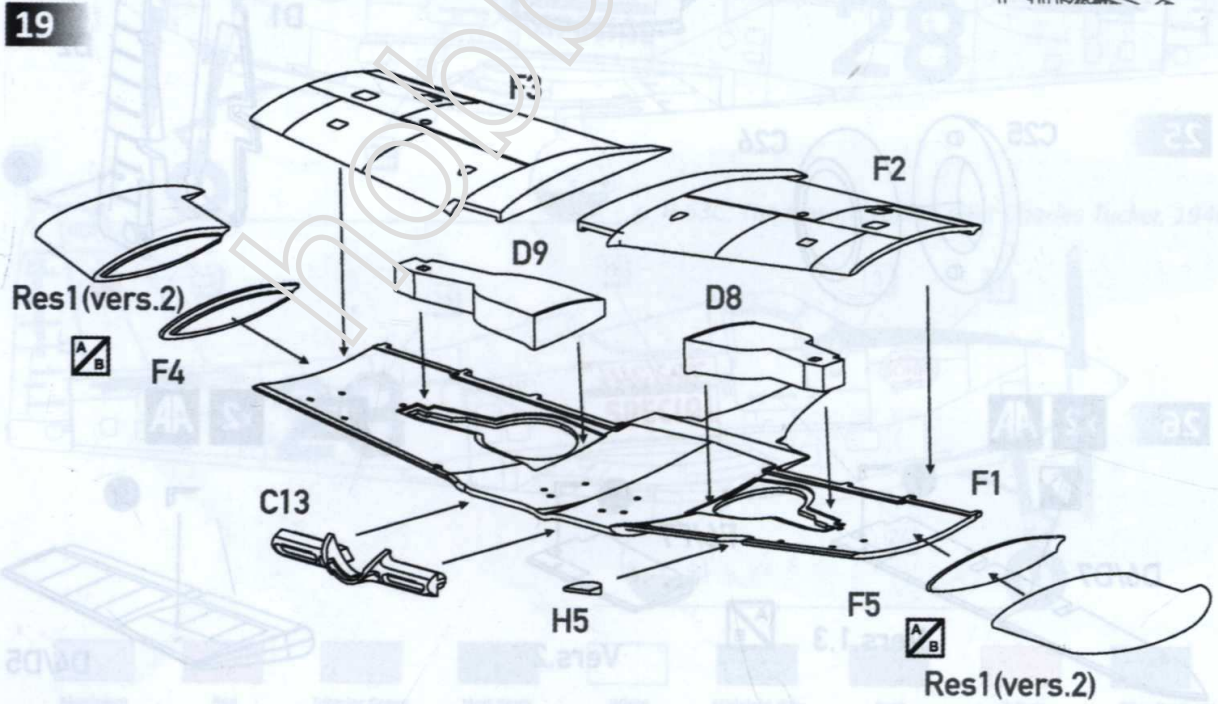
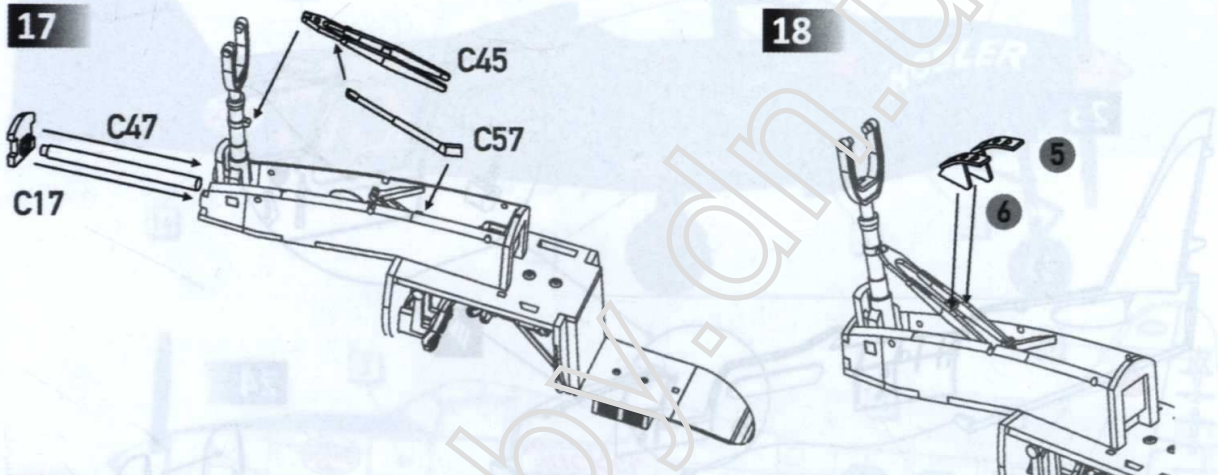
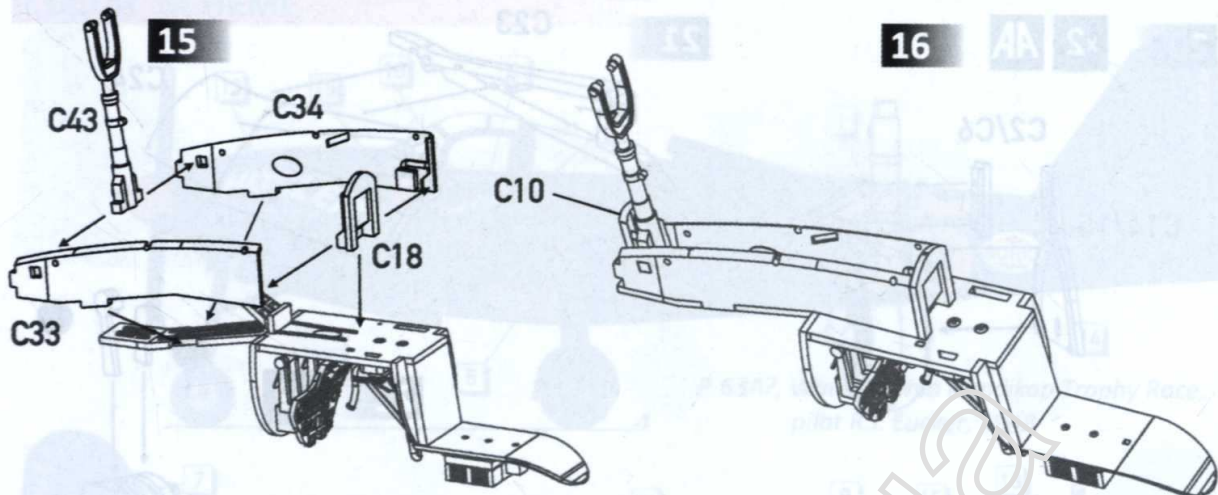

20 x2 AA

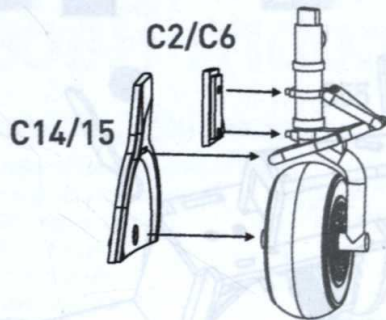

21 C23

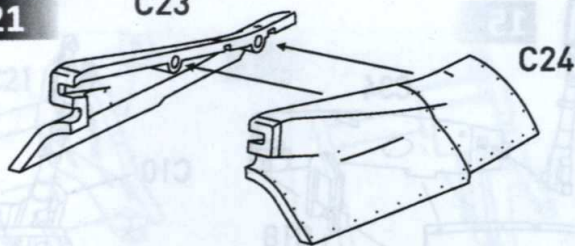

22 x2

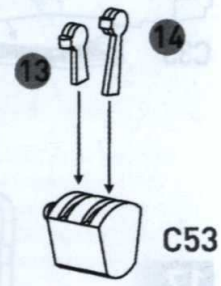

23

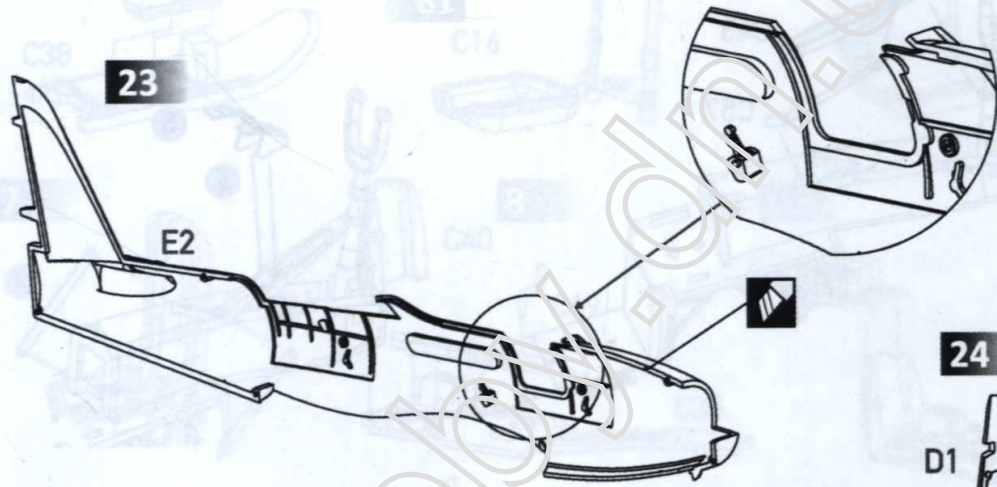

24

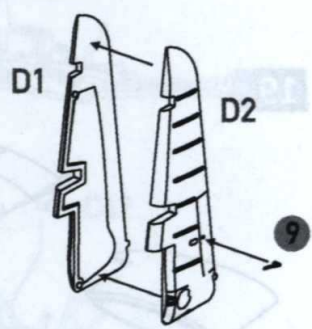

25

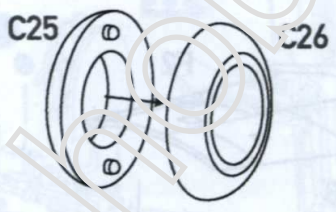

26 x2 AA



Vers.1,3

F6/F7

Vers.2

27 x2 AA

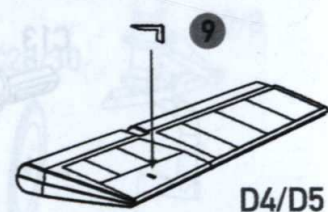

D4/D5



28

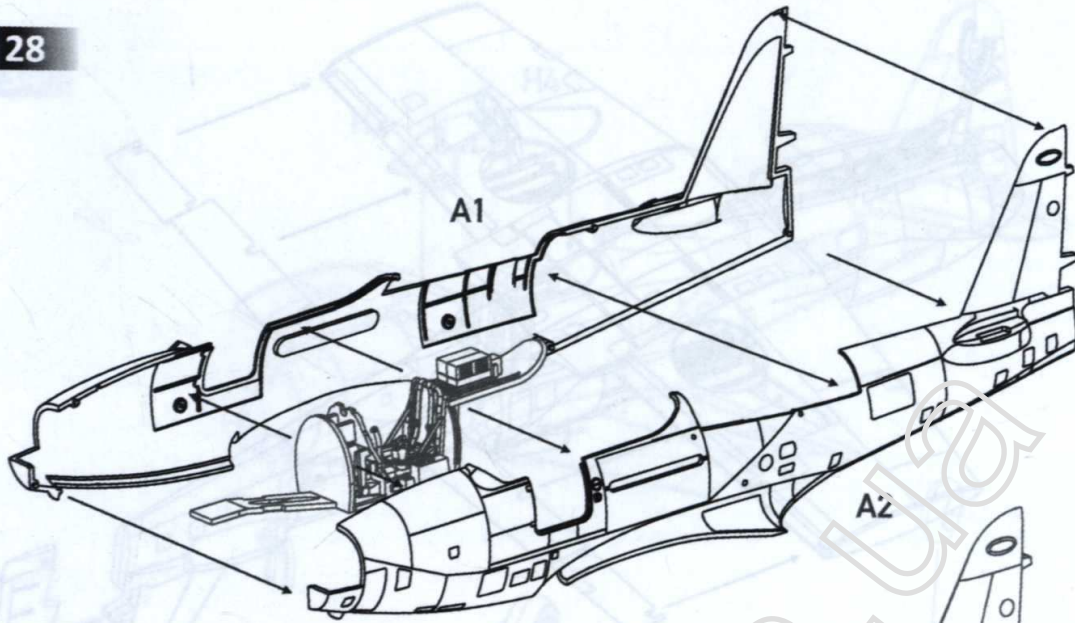

29

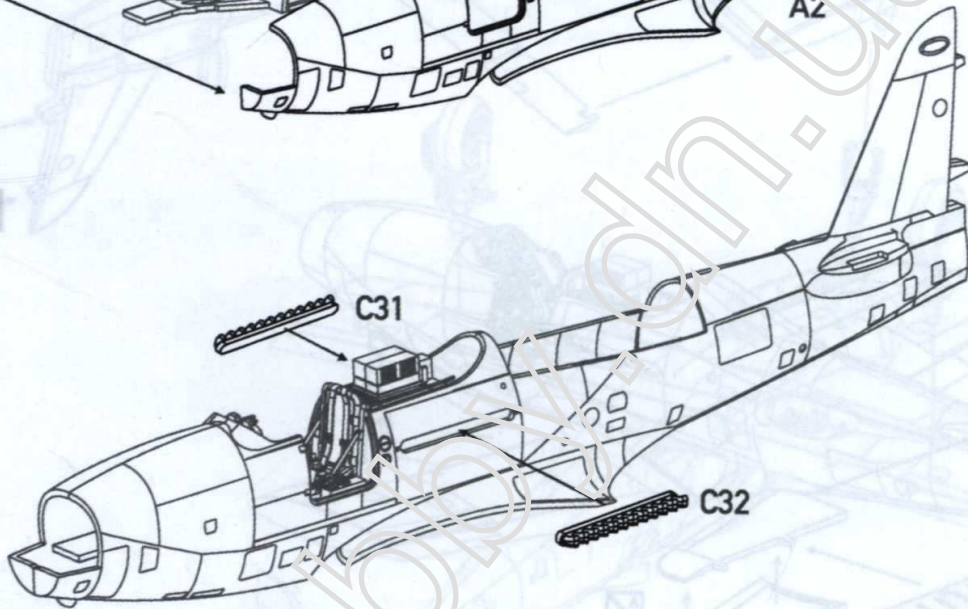

30

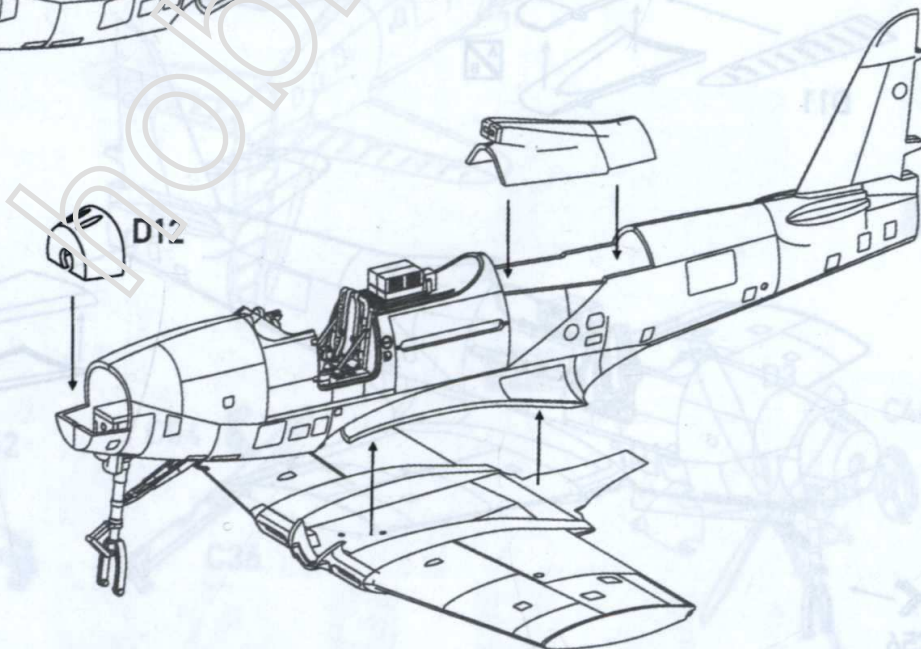

31

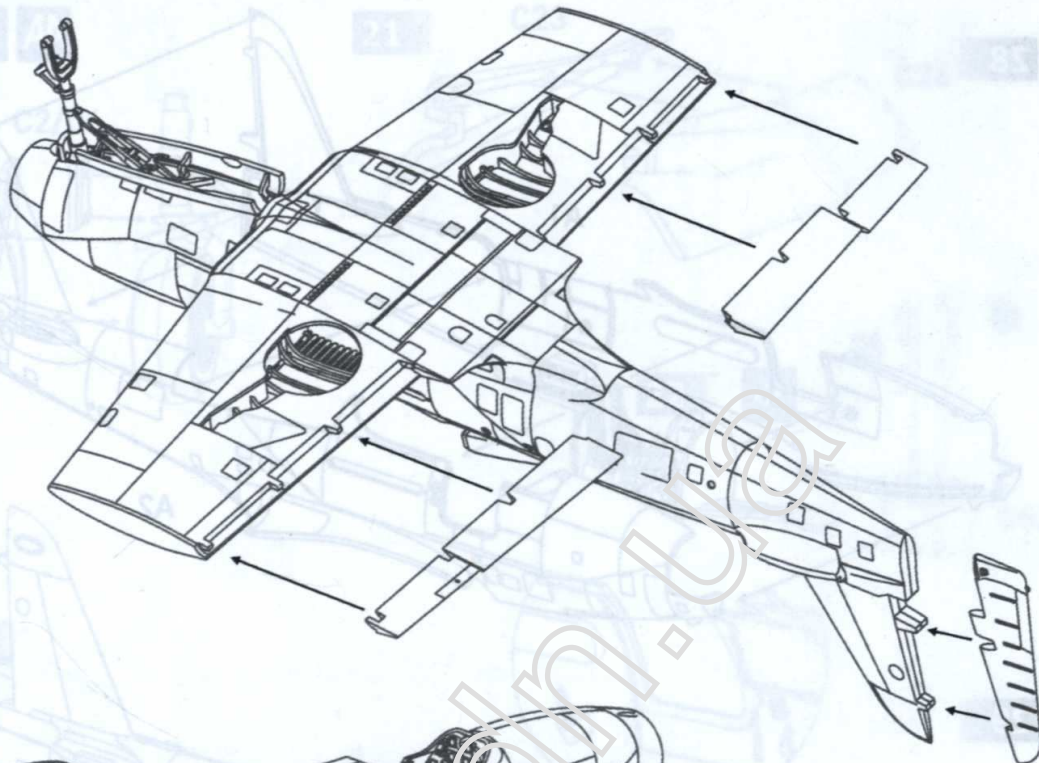

32

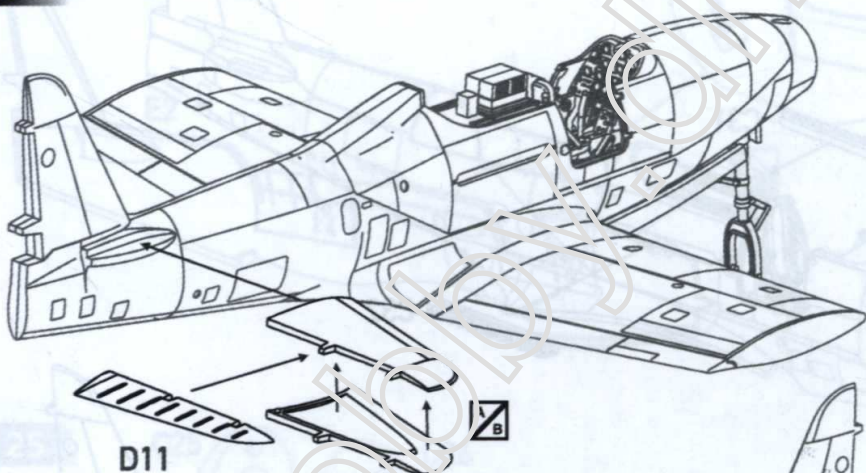

D11

33

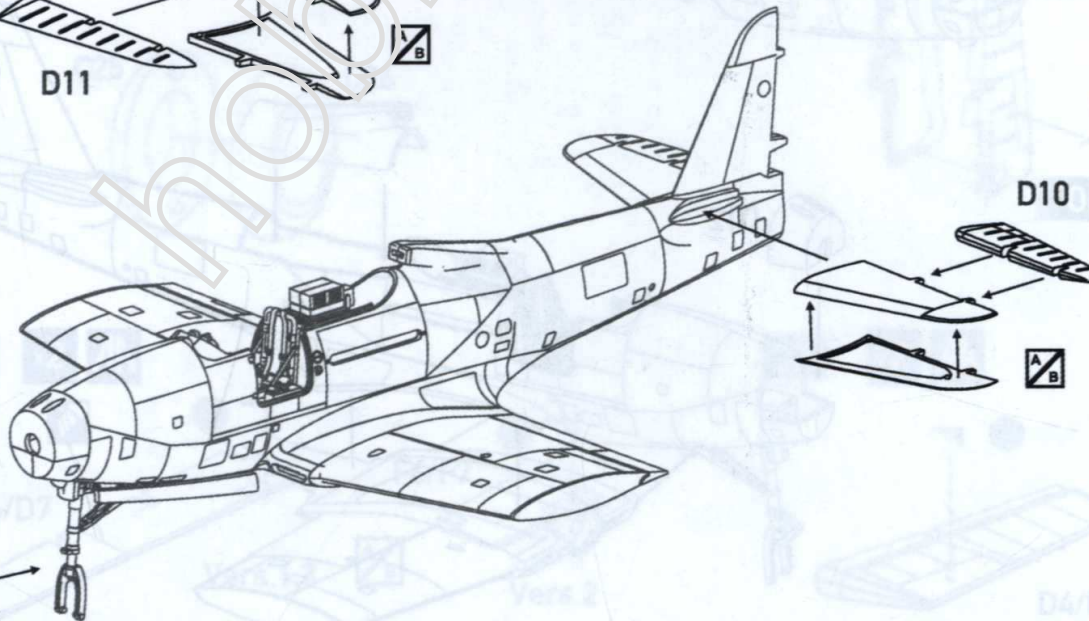

D10

C56



34

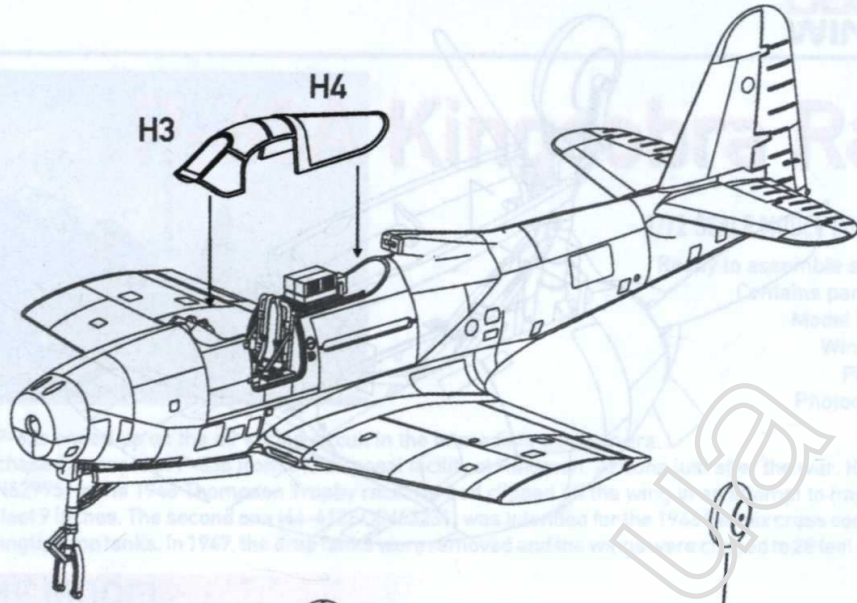

35

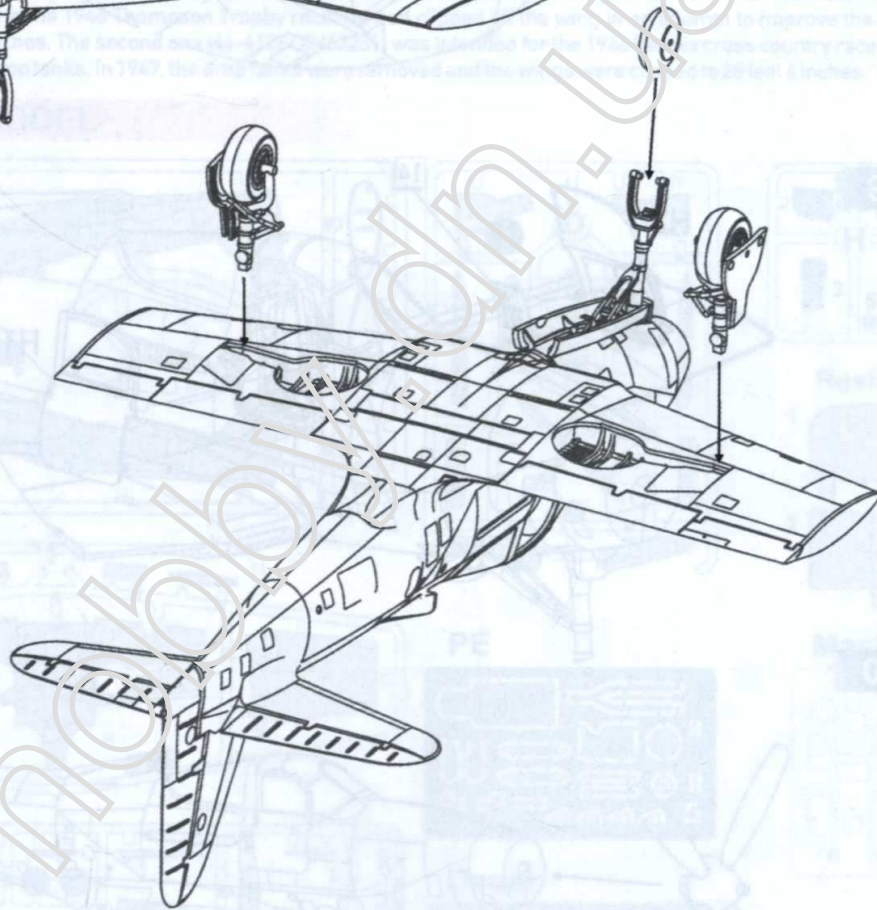

36

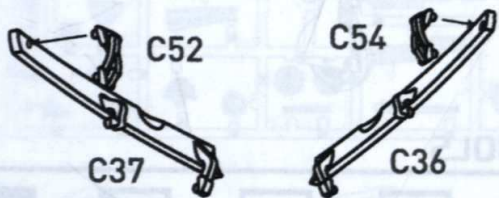

37

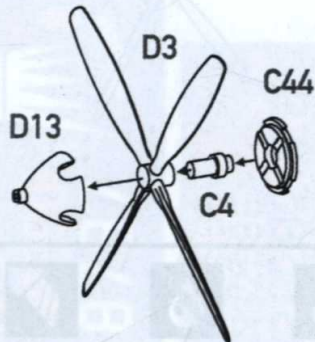

INSTRUCTION KIT

To assemble scale models kit  
 Contains part for one model.  
 Model length: 104 mm  
 Wingspan: 96 mm  
 Plastic parts: 76  
 Photocrital parts: 15

Numerous surplus P-63s were built. Charles Tucker purchased a P-63 (civilian register N5279) in 1947. It was modified to improve the speed, including the span to 25 feet 9 inches. The second one (N5280) was modified for the 1948 cross-country race. It was heavily fitted with two wing tanks. In 1947, the 2 1/2" tanks were removed and the wings were spanned to 25 feet 8 inches.

38

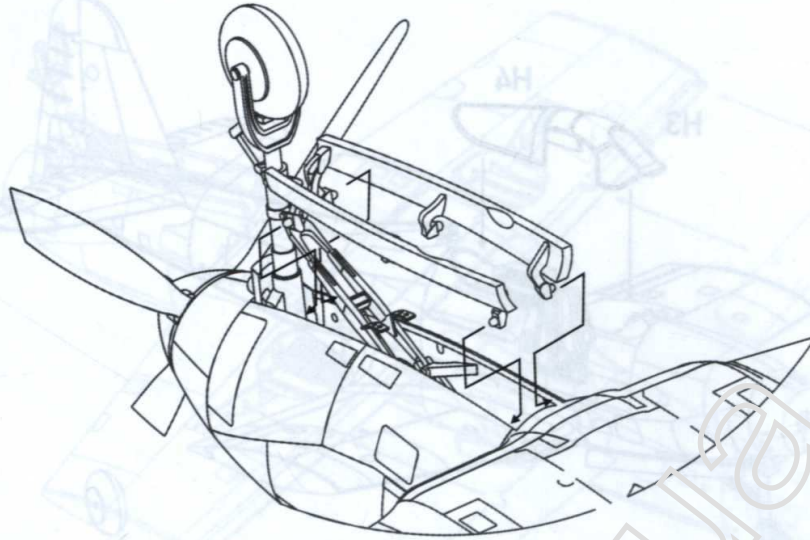

39

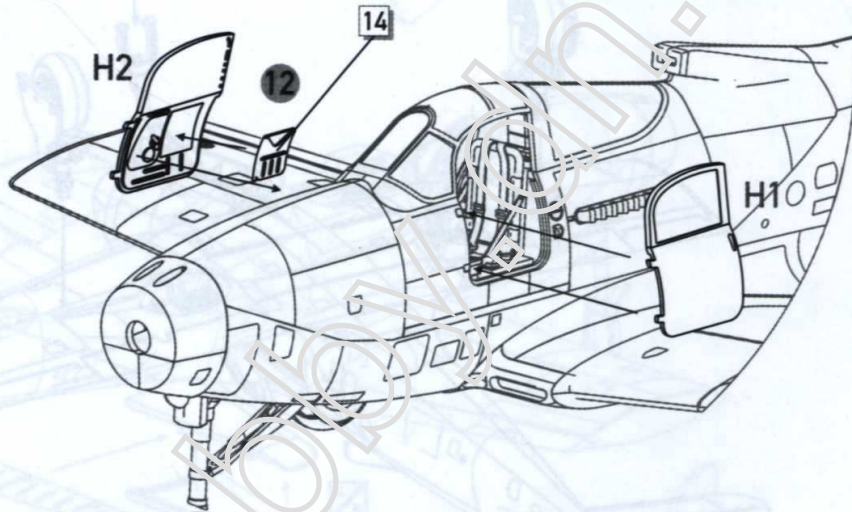

40

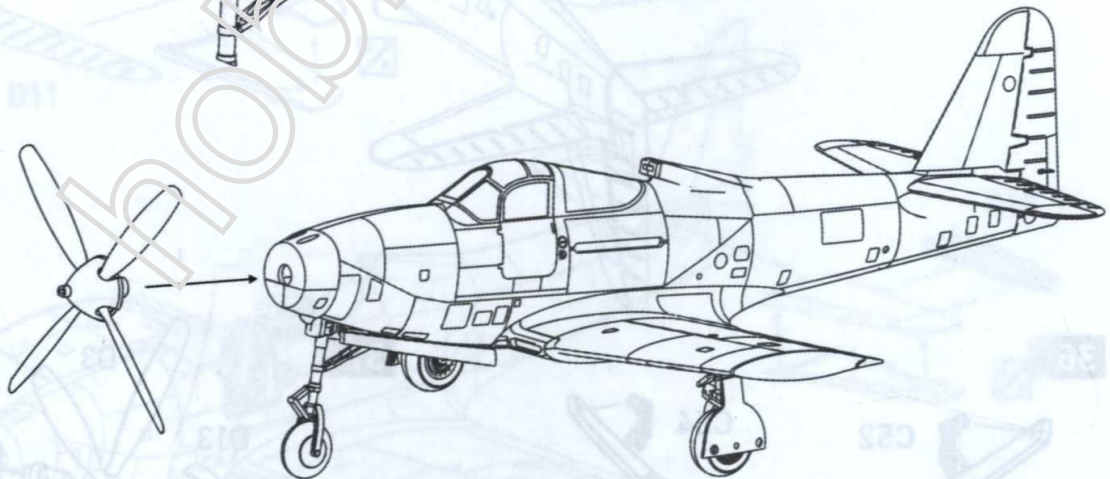

USED SYMBOLS



CEMENT



DON'T CEMENT



REMOVE



SYMMETRICAL



MULTIPLE



BEND



OPEN WHOLE



VARIANTS



TO PAINT



# COLOR SCHEME

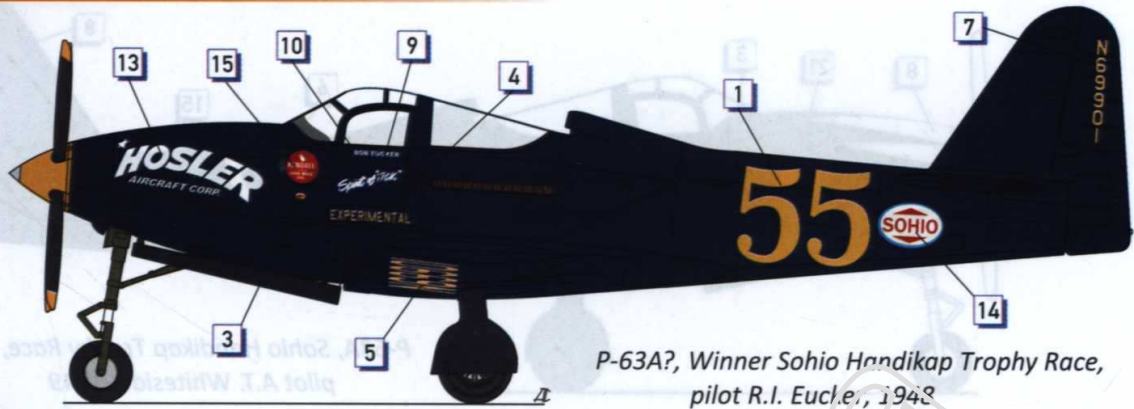

P-63A?, Winner Sohio Handicap Trophy Race, pilot R.I. Eucler, 1948

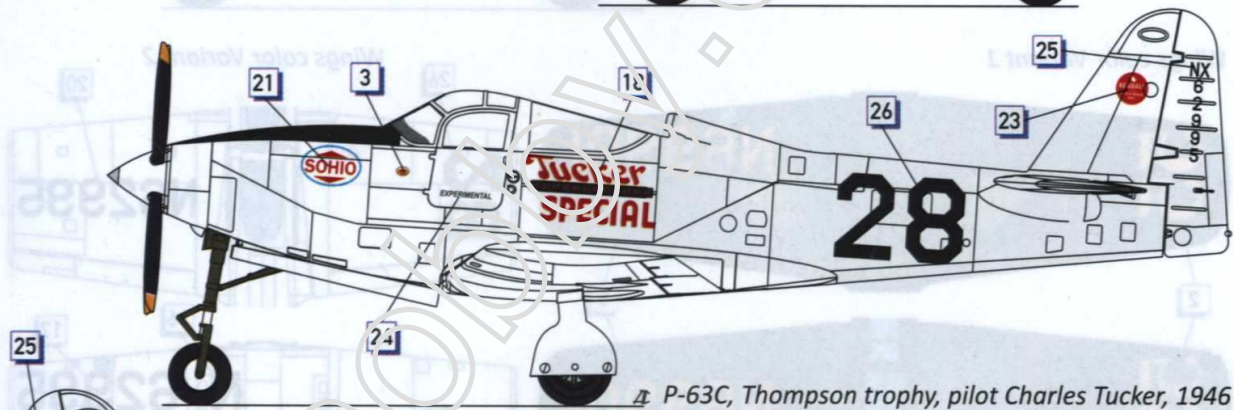

P-63C, Thompson trophy, pilot Charles Tucker, 1946

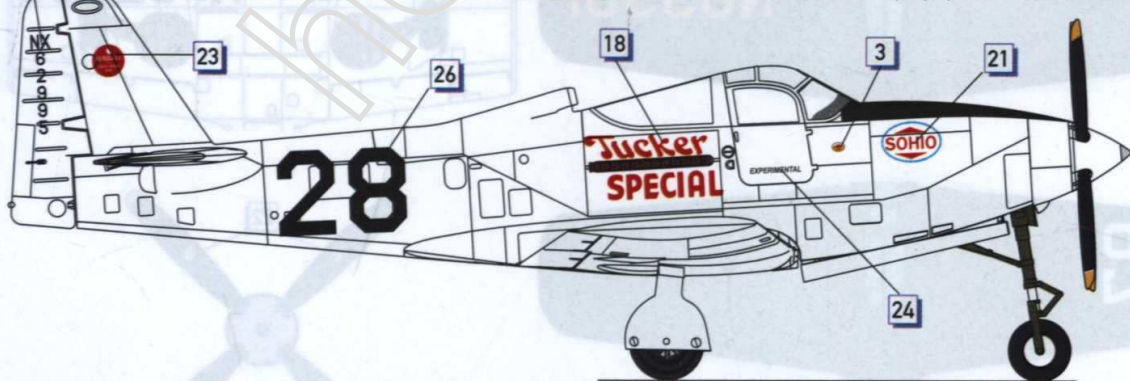

- |                        |                   |                |                          |                     |                             |                     |                      |                          |
|------------------------|-------------------|----------------|--------------------------|---------------------|-----------------------------|---------------------|----------------------|--------------------------|
|                        |                   |                |                          |                     |                             |                     |                      |                          |
| Aluminum<br>Humbrol 56 | Red<br>Humbrol 60 | Interior Green | Matt Black<br>Humbrol 56 | White<br>Humbrol 22 | Midnight Blue<br>Humbrol 15 | Rust<br>Humbrol 113 | Yellow<br>Humbrol 24 | Olive Drab<br>Humbrol 66 |

**Bell P-63A Kingcobra racer**

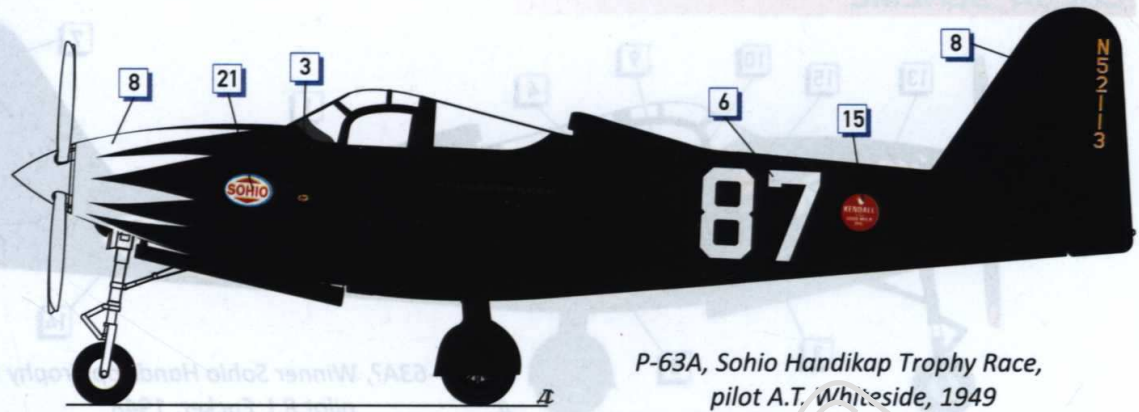

P-63A, Sohio Handikap Trophy Race, pilot A.T. Whiteside, 1949



Wings color Variant 1



Wings color Variant 3

Wings color Variant 2

