

**eduard**



# CAMEL & Co.

## 1/48

# Instruction sheet

Limited Edition  
Dual Combo

11151-NAV1

ATTENTION



UPOZORNĚNÍ



ACHTUNG



ATTENTION



注意



Carefully read instruction sheet before assembling. When you use glue or paint, do not use near open flame and use in well ventilated room. Keep out of reach of small children. Children must not be allowed to suck any part, or pull vinyl bag over the head.



Před započatím stavby si pečlivě prostudujte stavební návod. Při používání barev a lepidel pracujte v dobře větrané místnosti. Lepidla ani barvy nepoužívejte v blízkosti otevřeného ohně. Model není určen malým dětem, mohlo by dojít k požití drobných dílů.

INSTRUCTION SIGNS

\* INSTR. SYMBOLS

\* INSTRUKTION SINNBILDEN

\* SYMBOLES

\* 記号の説明

OPTIONAL  
VOLBABEND  
OHNOUTSAND  
BROUSITOPEN HOLE  
VYVRTAT OTVORSYMETRICAL ASSEMBLY  
SYMETRICKÁ MONTÁŽREMOVE  
ODŘÍZNOUTREVERSE SIDE  
OTOČITAPPLY EDUARD MASK  
AND PAINT  
POUŽIT EDUARD MASK  
NABARVIT

PARTS



DÍLY



TEILE



PIÈCES



部品

## PLASTIC PARTS

A&gt; 2 pcs.

82170 A

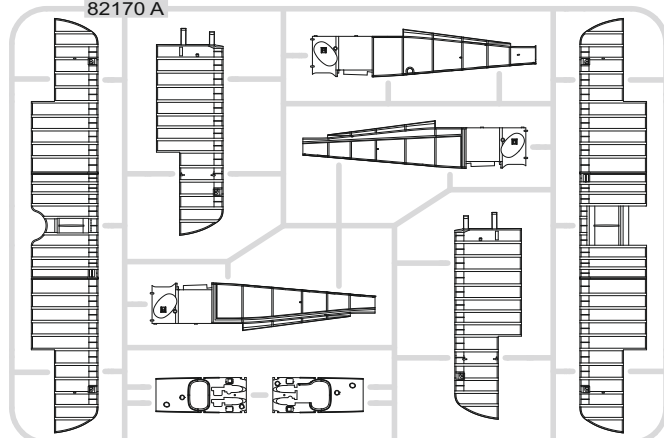

D&gt; 2 pcs.

82170 D

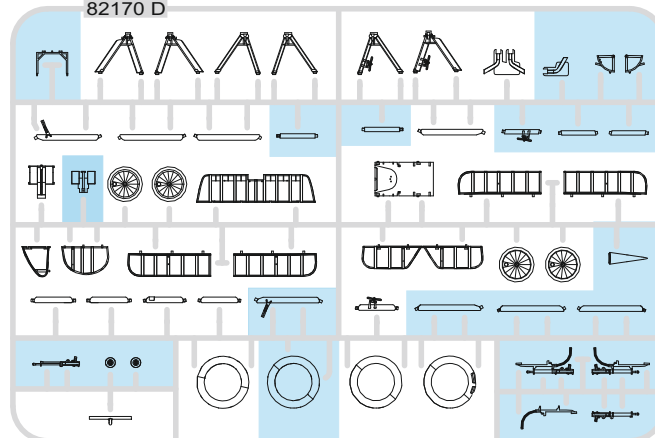

E&gt; 2 pcs.

82170 E

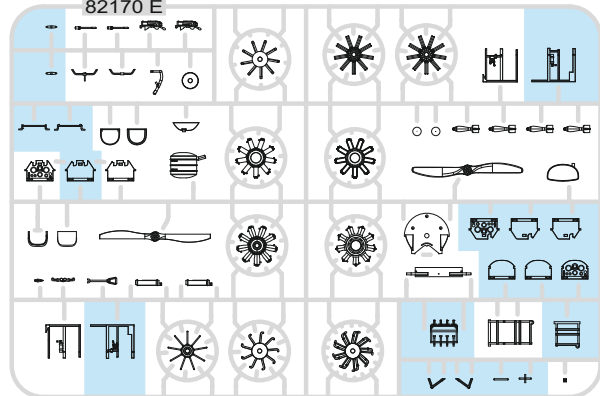

F&gt; 2 pcs.

82170 F

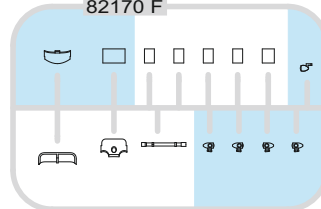
eduard  
MASK

2 pcs.

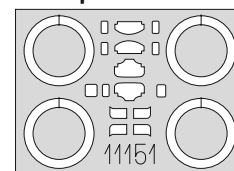
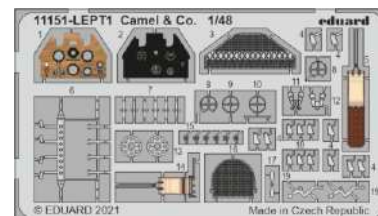
PE - PHOTO ETCHED DETAIL PARTS  
2 pcs.

-Parts not for use. -Teile werden nicht verwendet. -Pièces à ne pas utiliser. -Tyto díly nepoužívejte při stavbě. - 使用しない部品

COLOURS



BARVY



FARBEN



PEINTURE



色

GSI Creos (GUNZE)		MISSION MODELS	
AQUEOUS	Mr.COLOR	PAINTS	
H4	C4	MMP-007	YELLOW
H8	C8		SILVER
H11	C62	MMP-001	FLAT WHITE
H12	C33	MMP-047	FLAT BLACK
H15	C65		BRIGHT BLUE
H25	C34		SKY BLUE
H37	C43		WOOD BROWN
H51	C11	MMP-063	LIGHT GULL GRAY
H53	C13		NEUTRAL GRAY
H78	C38		OLIVE GREEN
H84	C42		MAHOGANY

GSI Creos (GUNZE)		MISSION MODELS	
AQUEOUS	Mr.COLOR	PAINTS	
H85	C45		SAIL COLOR
H327	C327	MMP-101	RED
H328	C328		BLUE
H329	C329	MMP-041	YELLOW
H338	C338	MMP-116	LIGHT GRAY
	C19		SANDY BROWN
Mr.METAL COLOR		METALLICS	
MC214	MMM-001		DARK IRON
MC215	MMM-004		COPPER
MC218	MMM-003		ALUMINIUM
MC219	MMM-009		BRASS

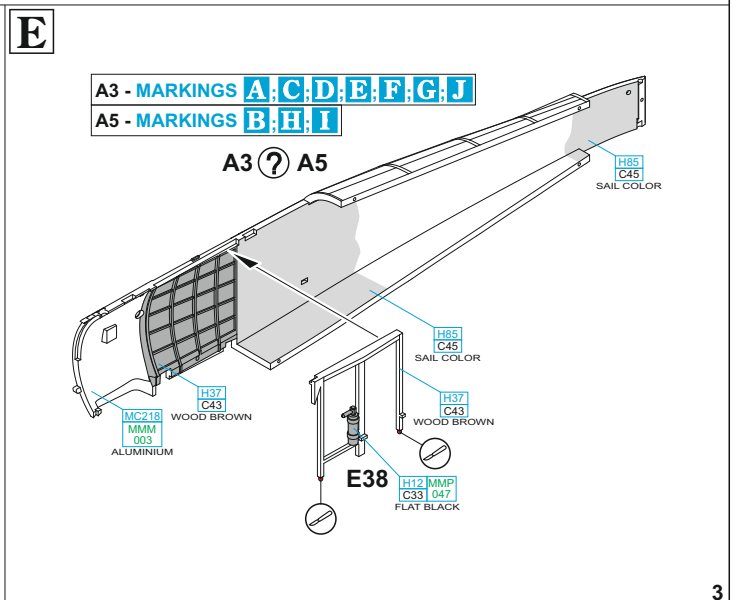
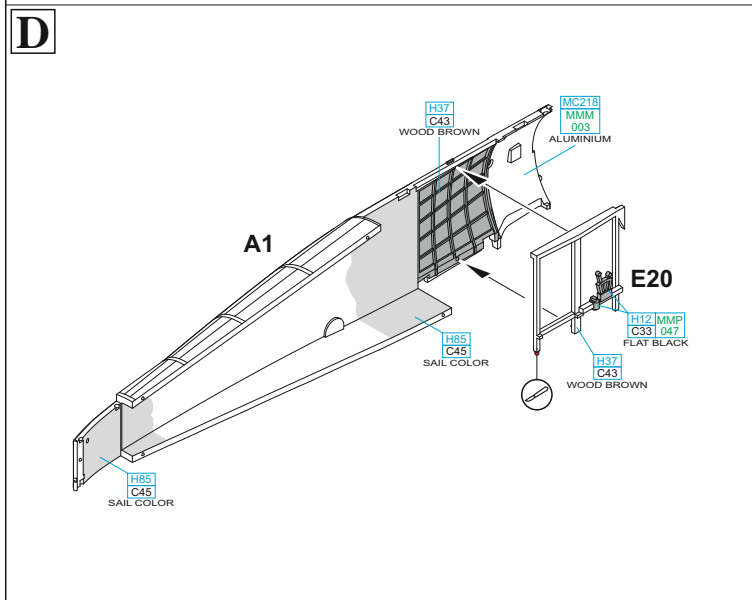
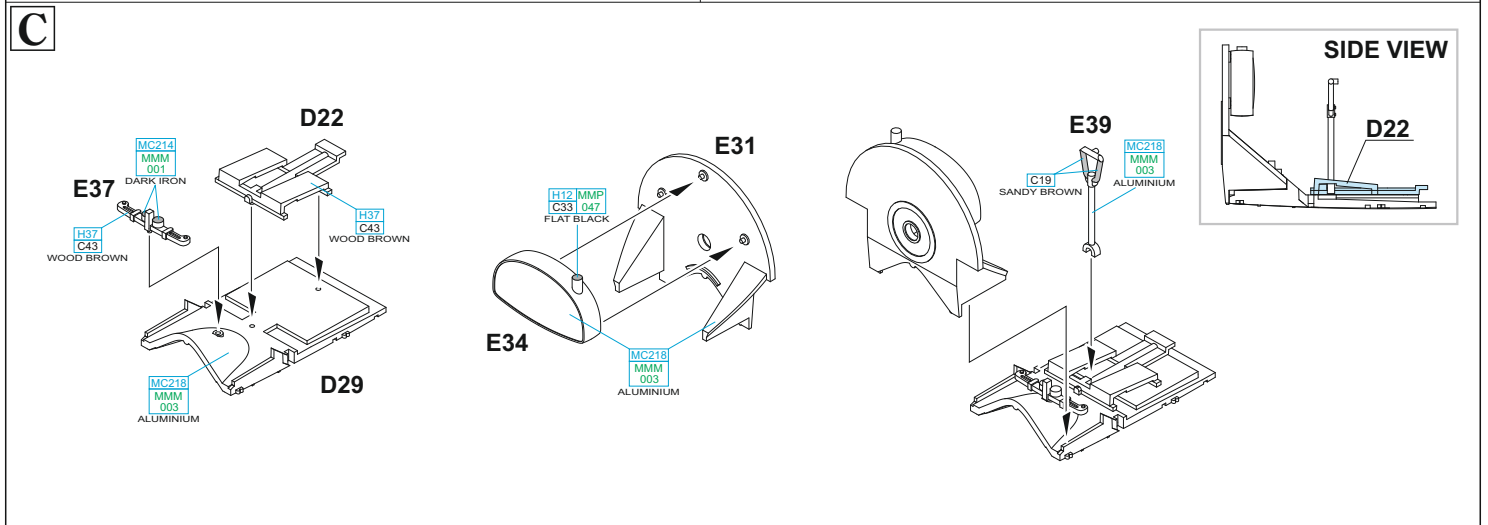
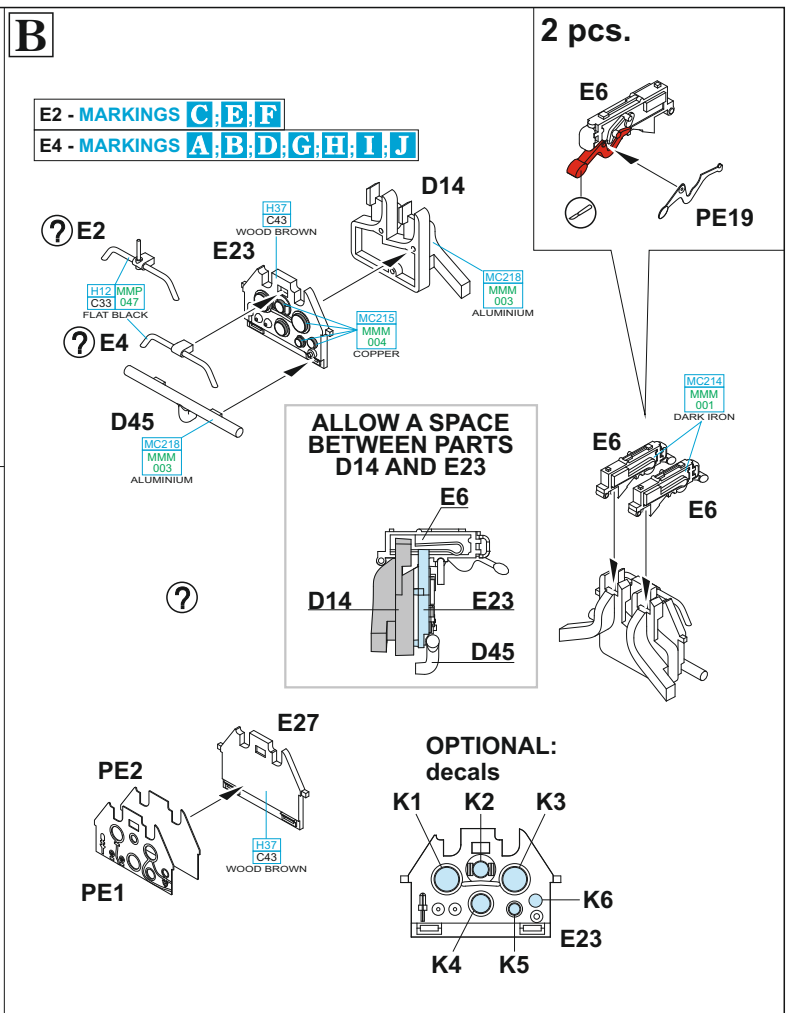
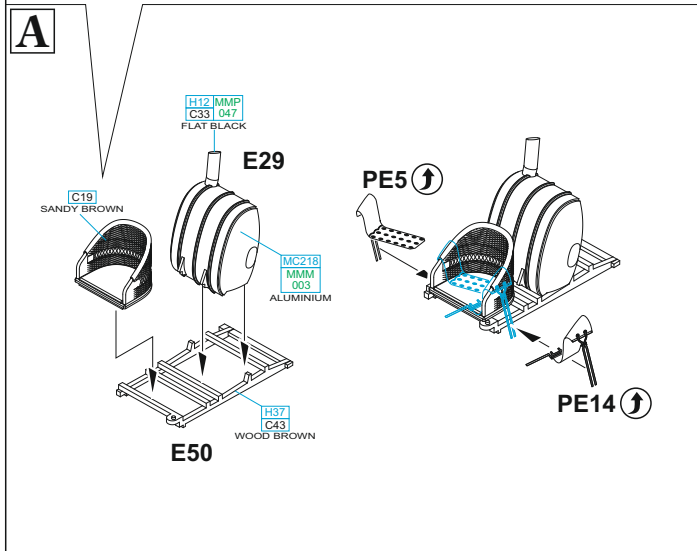
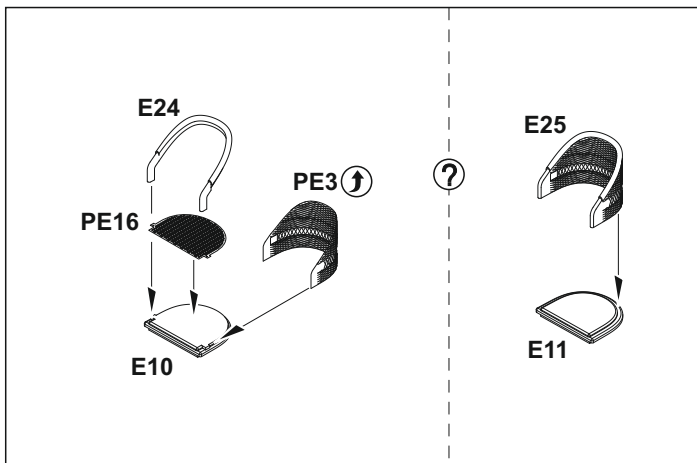

**SIDE VIEW**

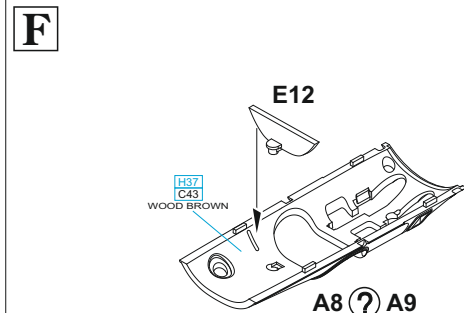
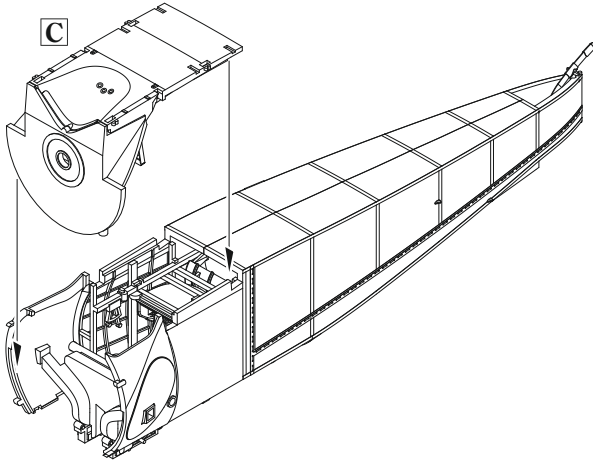
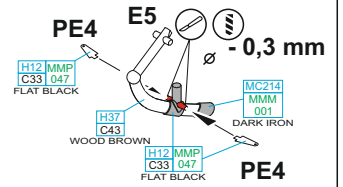
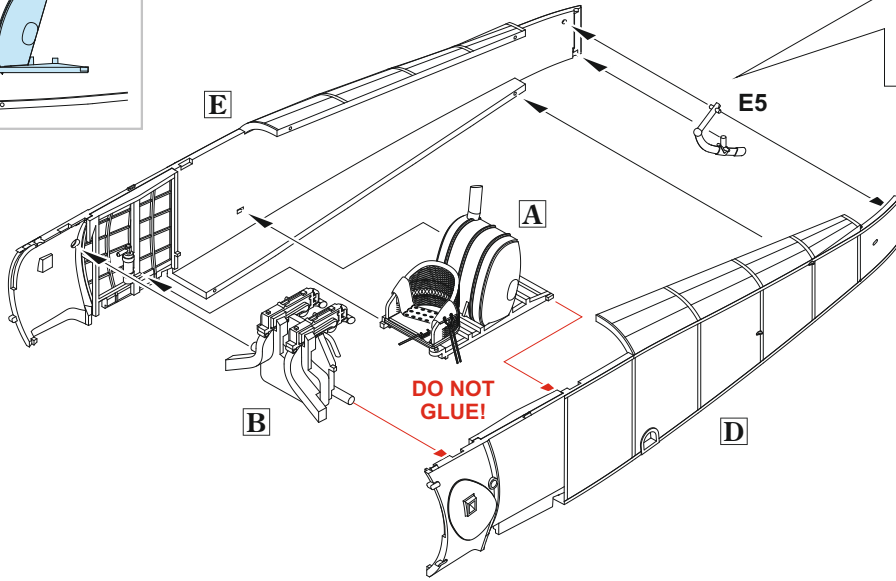
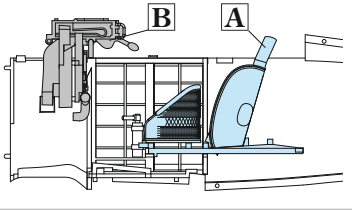

A8 ? A9

A8 - MARKINGS A, C, D, E, F, G, J  
A9 - MARKINGS B, H, I

**G** MARKINGS A, B, D, F  
**Bentley engine**

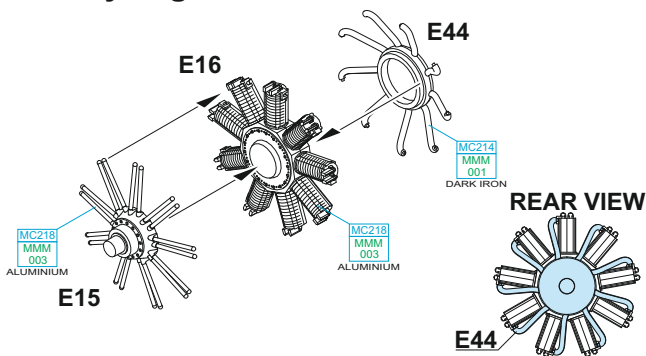

**H** MARKINGS C, E  
**Clerget engine**

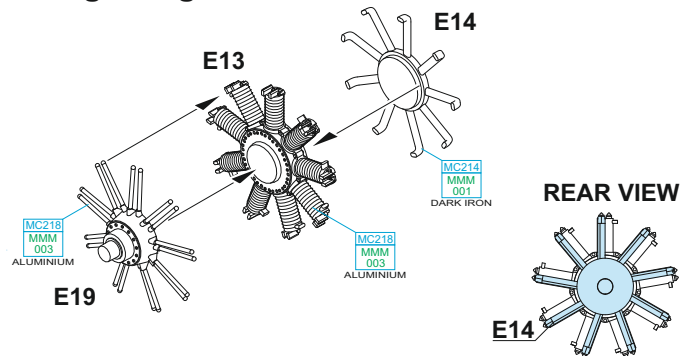

**I** MARKINGS G, J  
**Gnome engine**

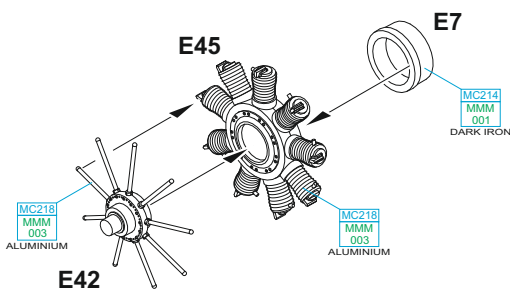

**J** MARKINGS H, I  
**Le Rhone engine**

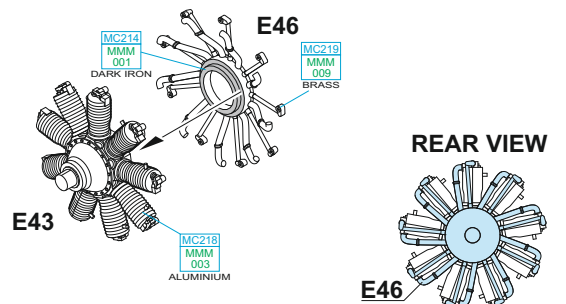

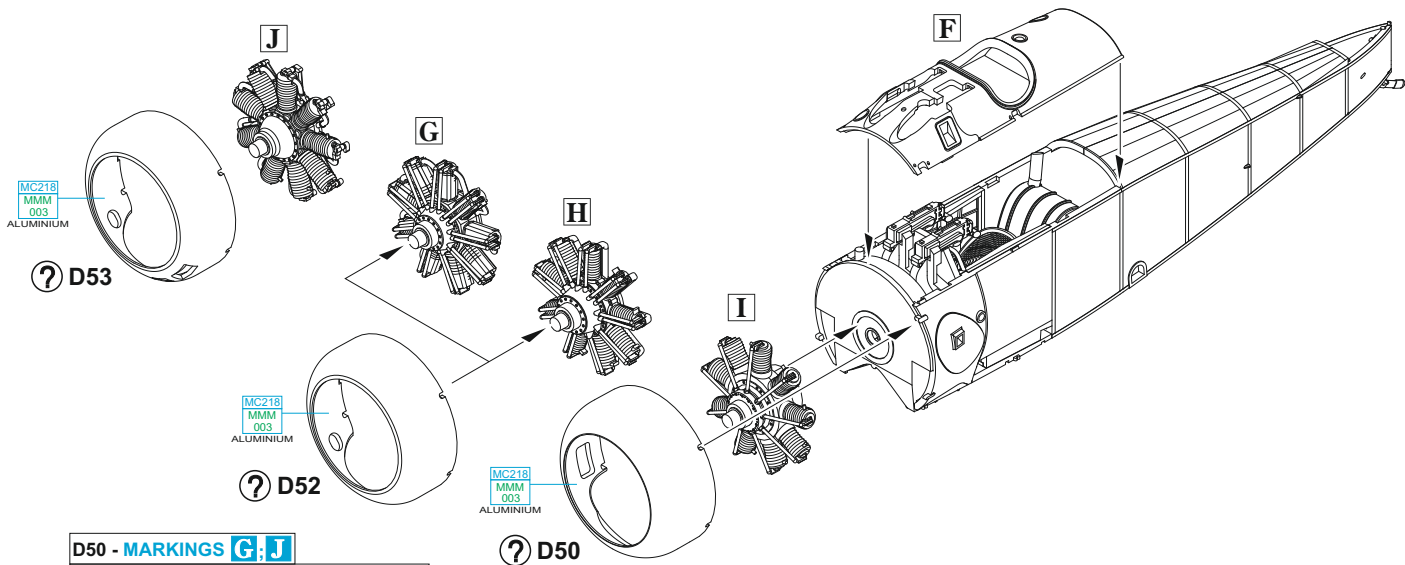

- D50 - MARKINGS **G; J**
- D52 - MARKINGS **A; B; C; D; E; F**
- D53 - MARKINGS **H; I**

MARKINGS **A; B; D; G; H; I; J**

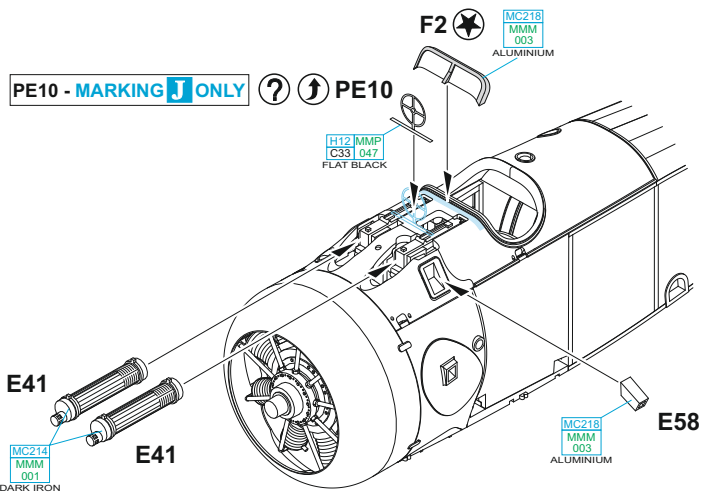

MARKINGS **C; E; F**

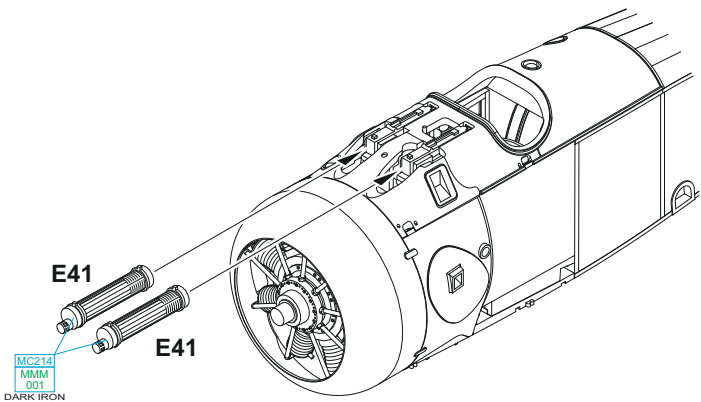

**DO NOT GLUE!**

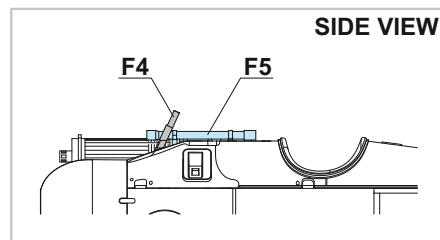
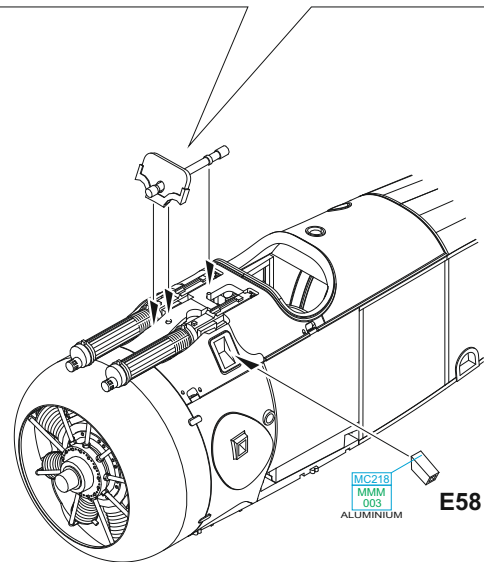
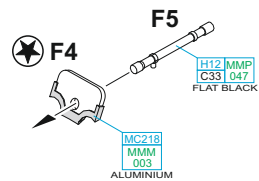

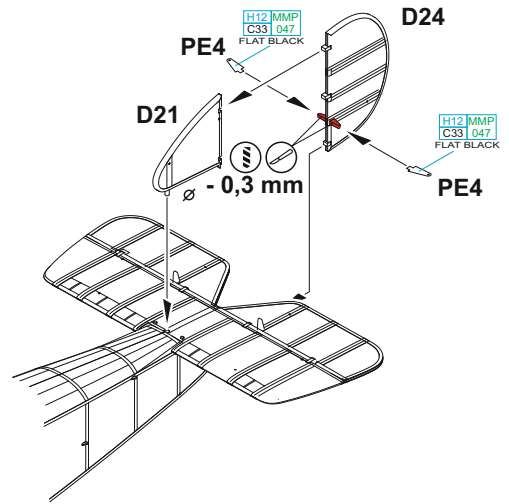
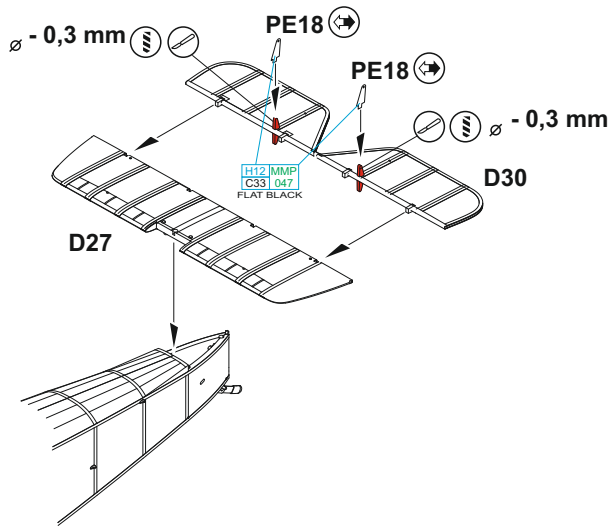

**K**

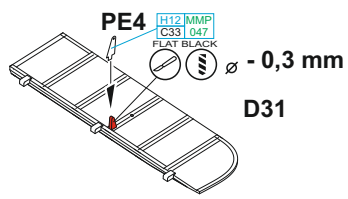

**L**

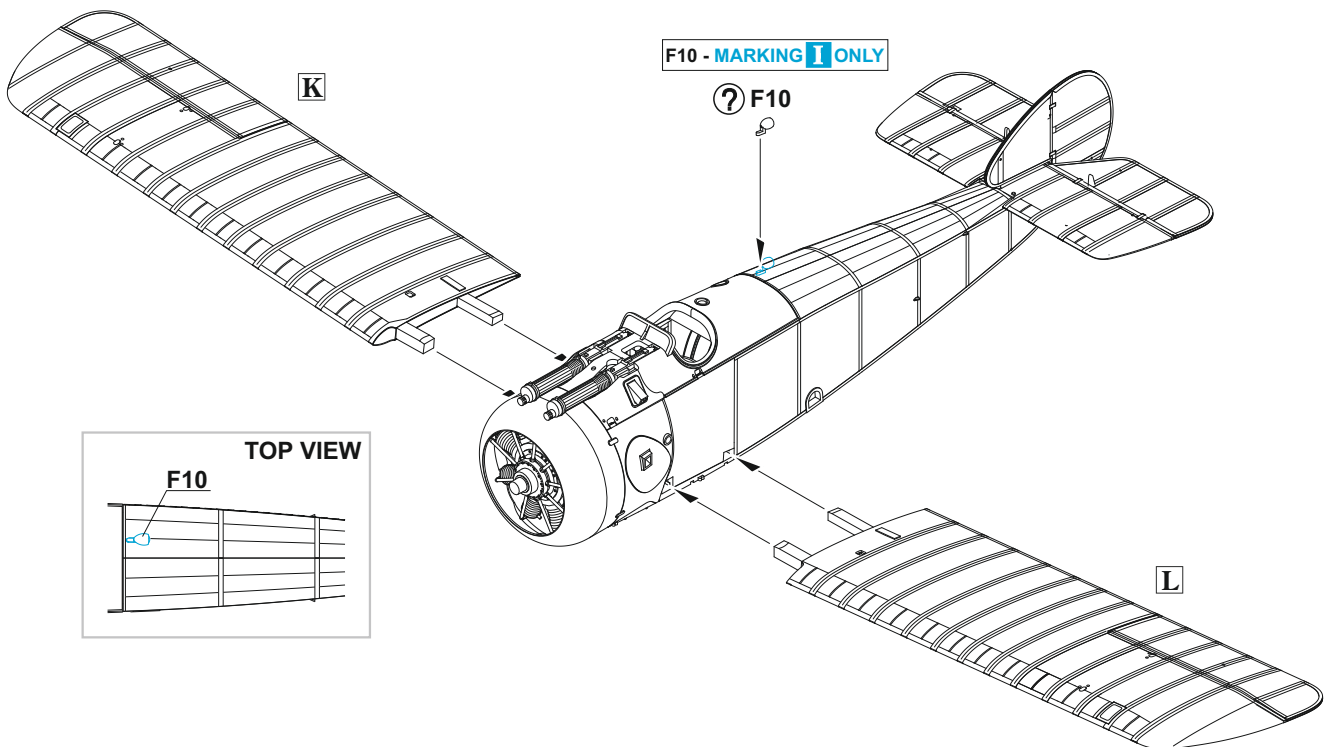
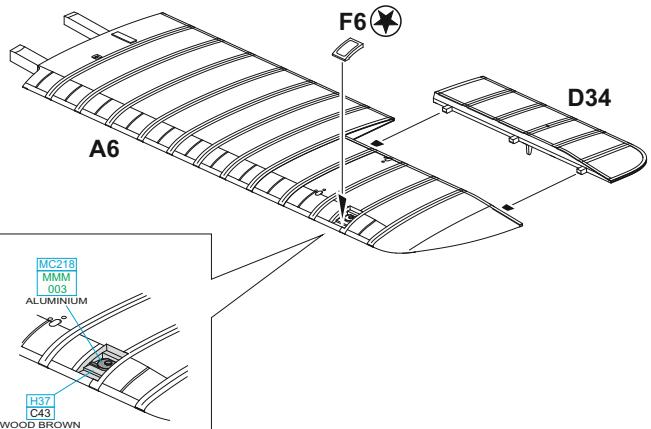
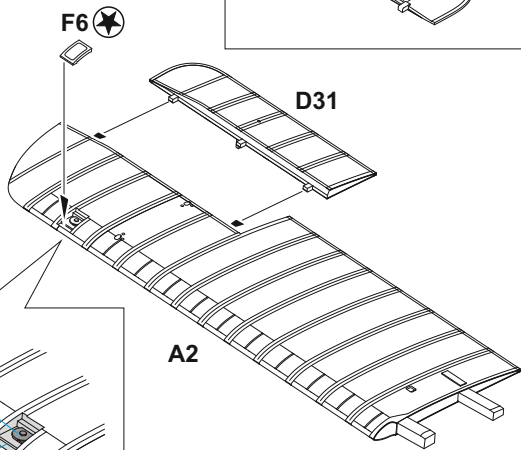
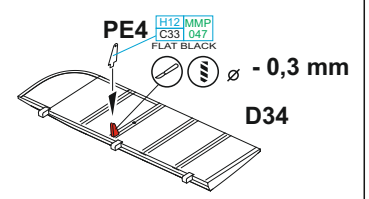

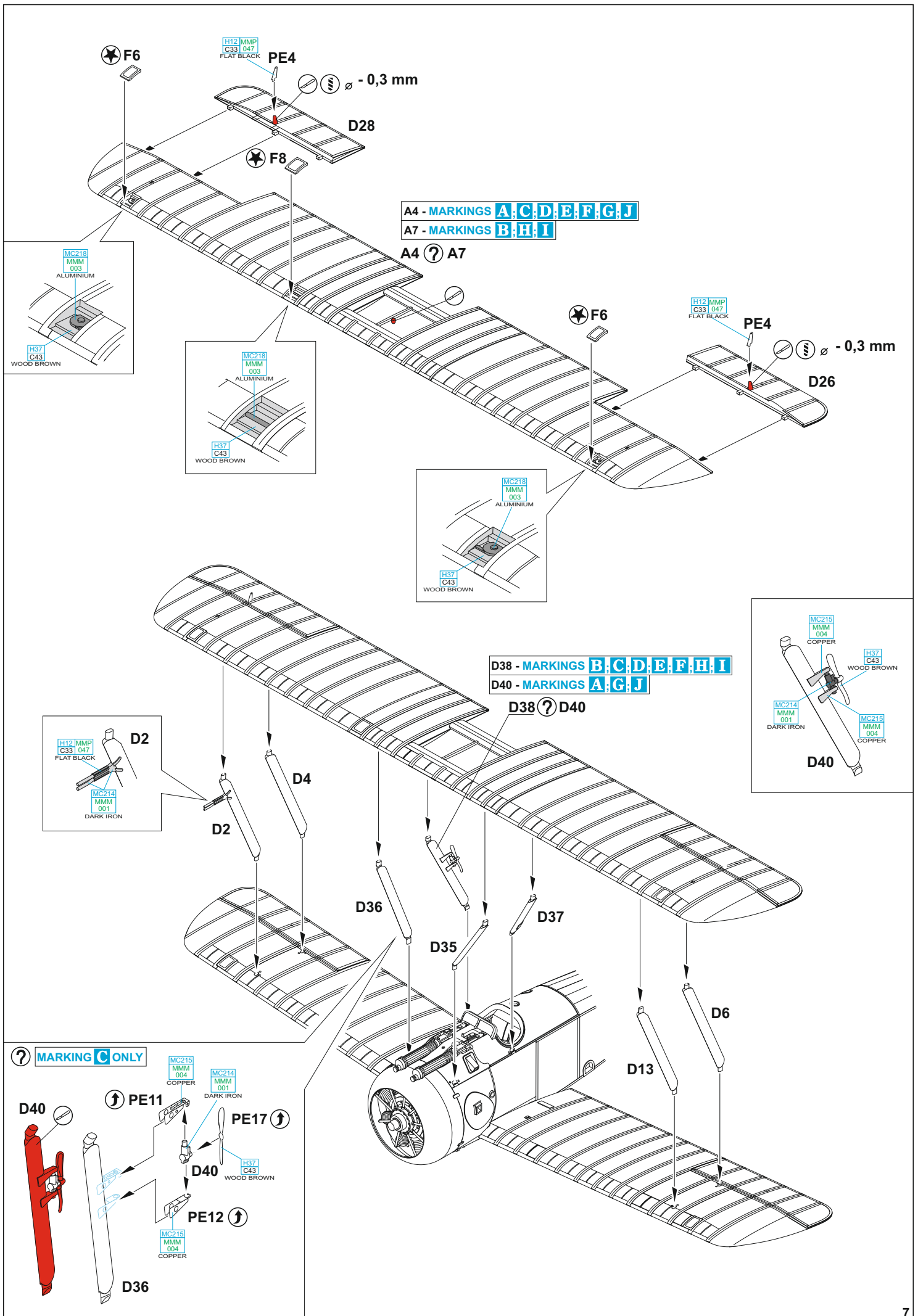

D25 - MARKINGS **B, E, F, I, J**  
 D32 - MARKINGS **A, C, D, G, H**

D25 ? D32

D3 - MARKINGS **G, H, I, J**  
 A4 - MARKINGS **A, B, C, D, E, F**

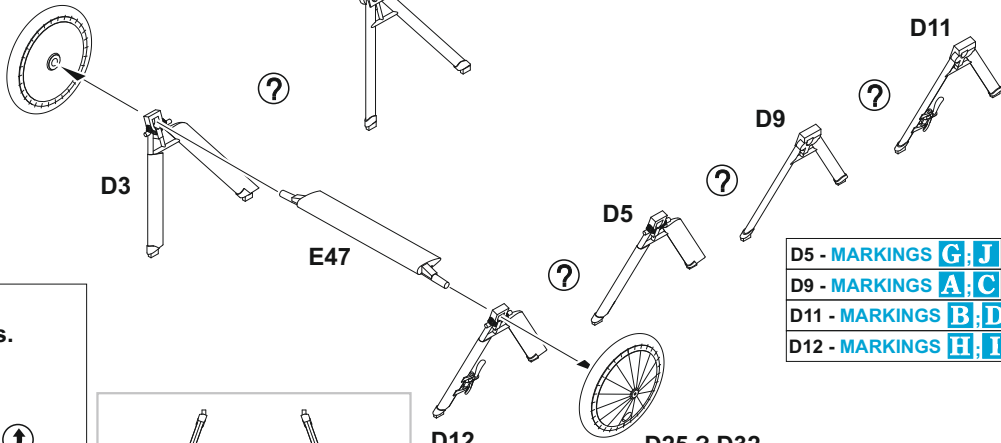
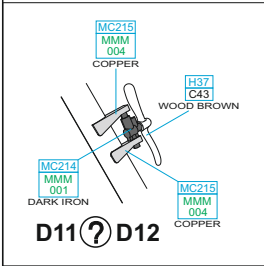

D5 - MARKINGS **G, J**  
 D9 - MARKINGS **A, C**  
 D11 - MARKINGS **B, D, E, F**  
 D12 - MARKINGS **H, I**

D25 - MARKINGS **B, E, F, I, J**  
 D32 - MARKINGS **A, C, D, G, H**

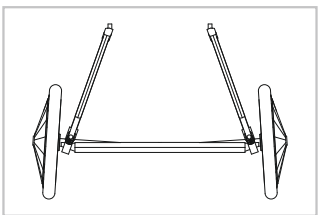
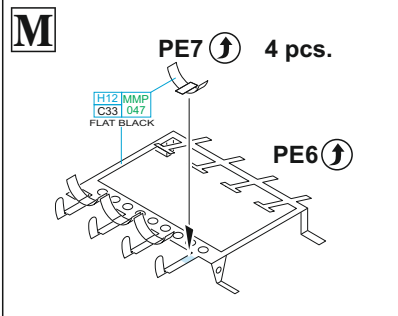

E3 - MARKING **I ONLY**

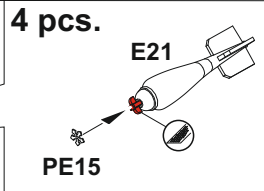
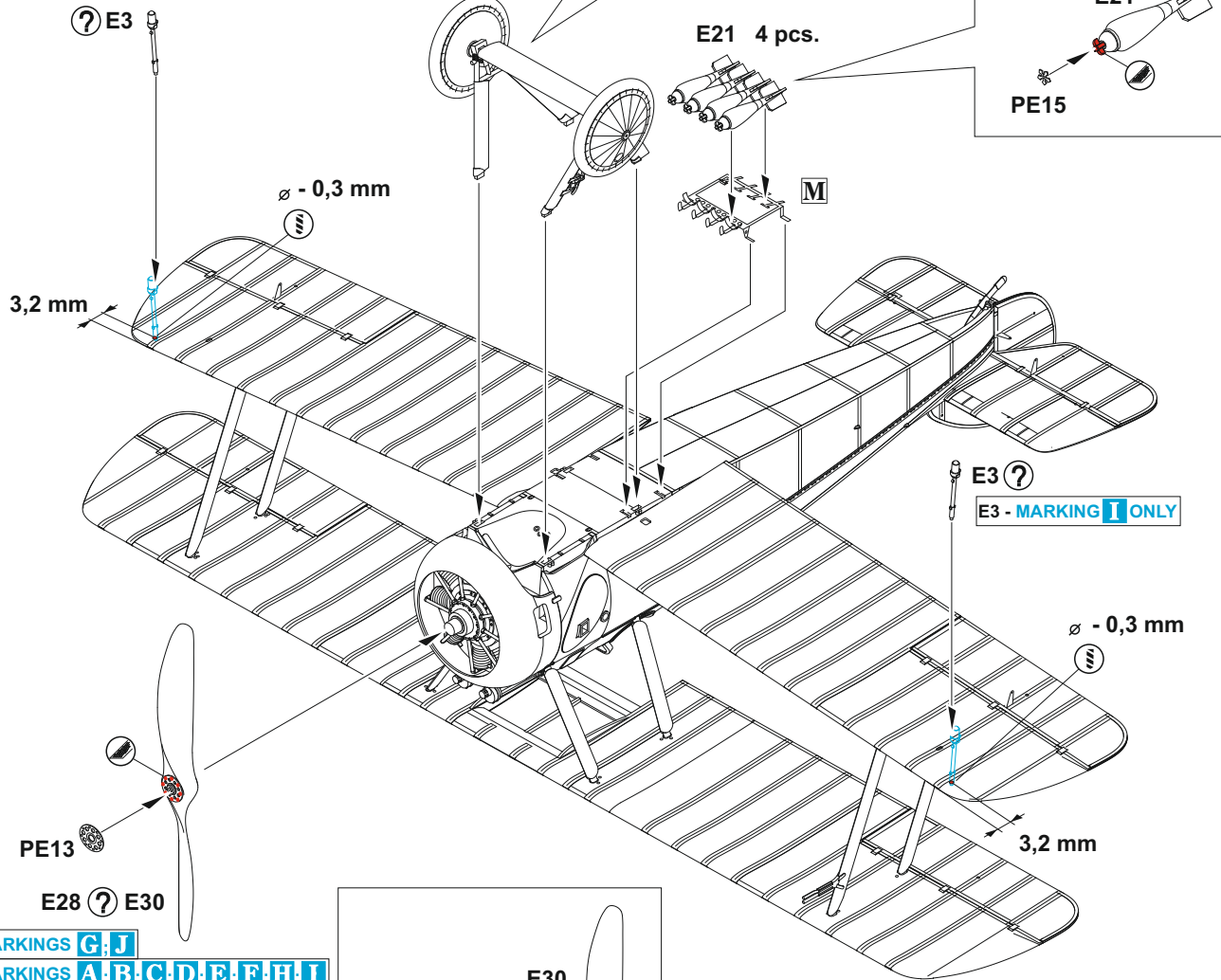

E28 - MARKINGS **G, J**  
 E30 - MARKINGS **A, B, C, D, E, F, H, I**

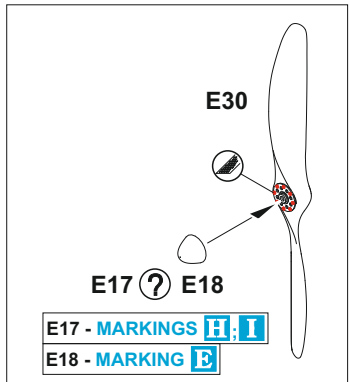

E17 - MARKINGS **H, I**  
 E18 - MARKING **E**



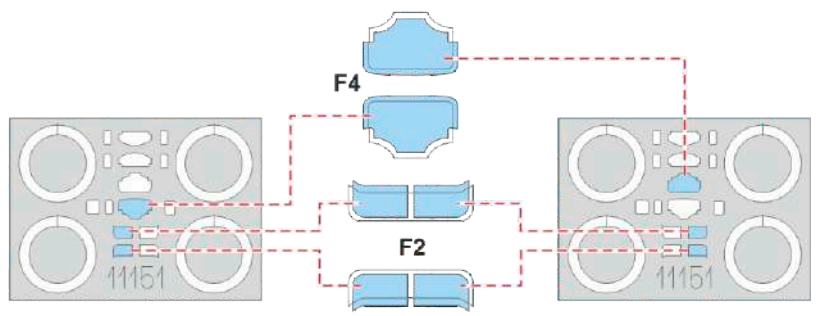
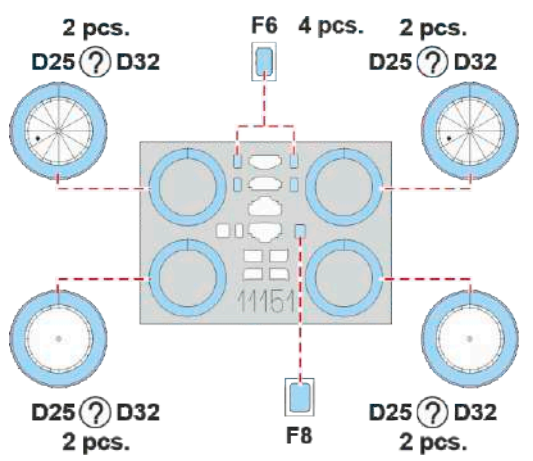
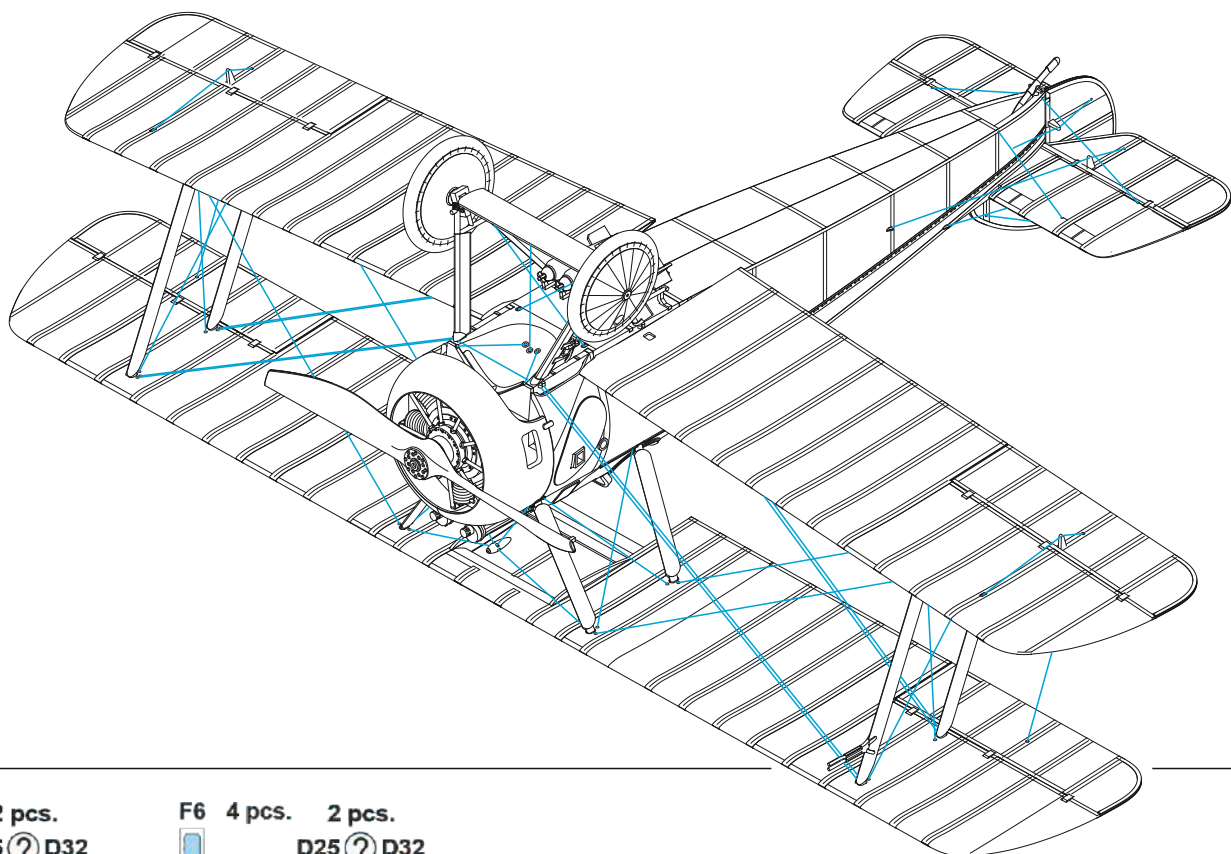
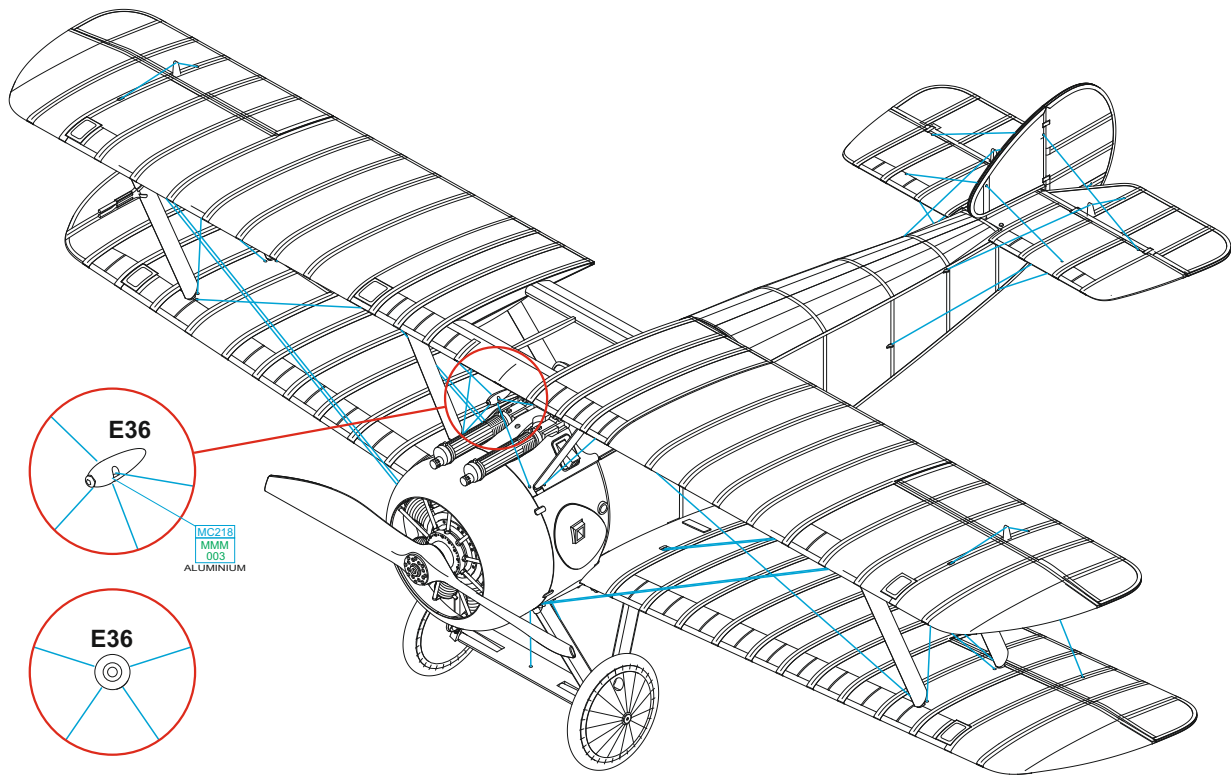

# RIGGING DIAGRAM

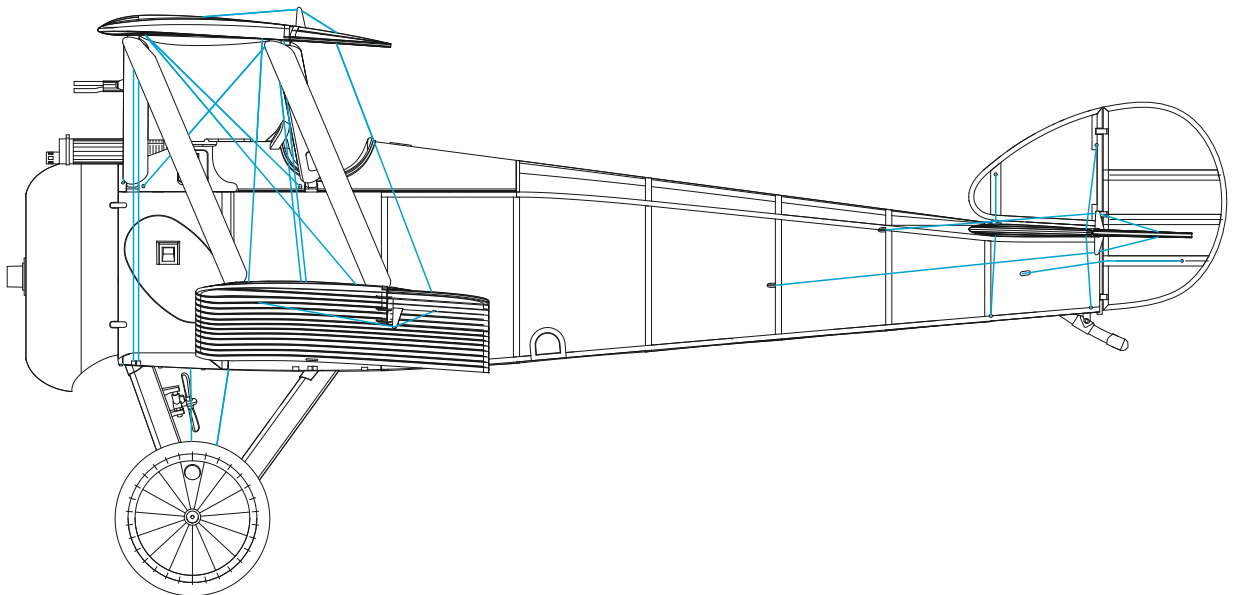
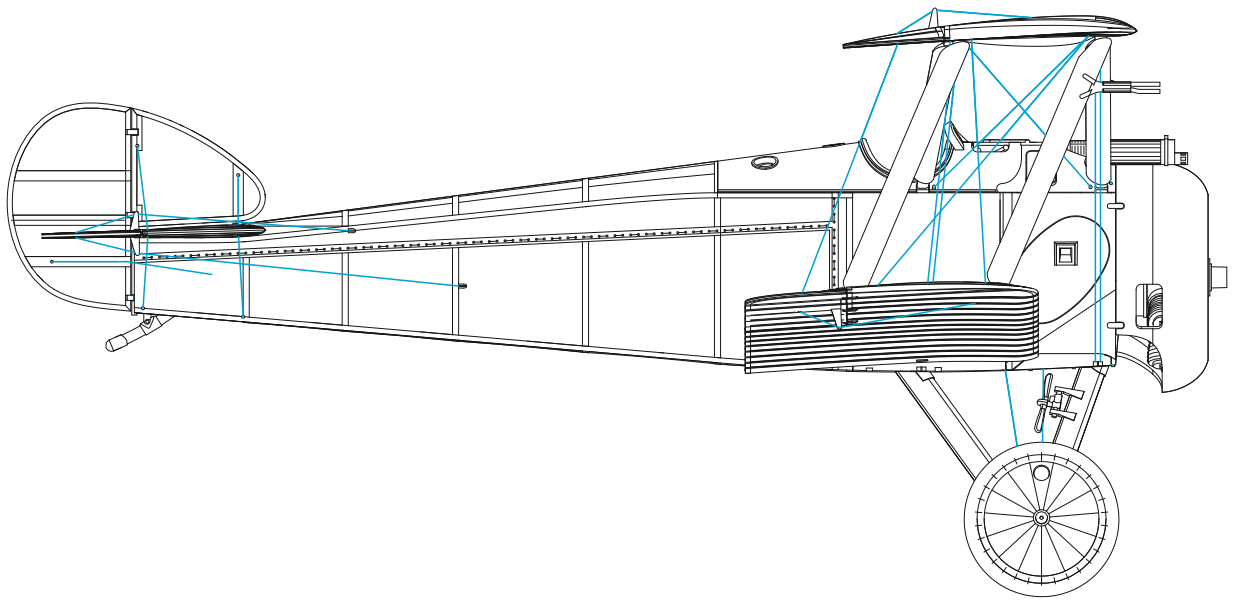
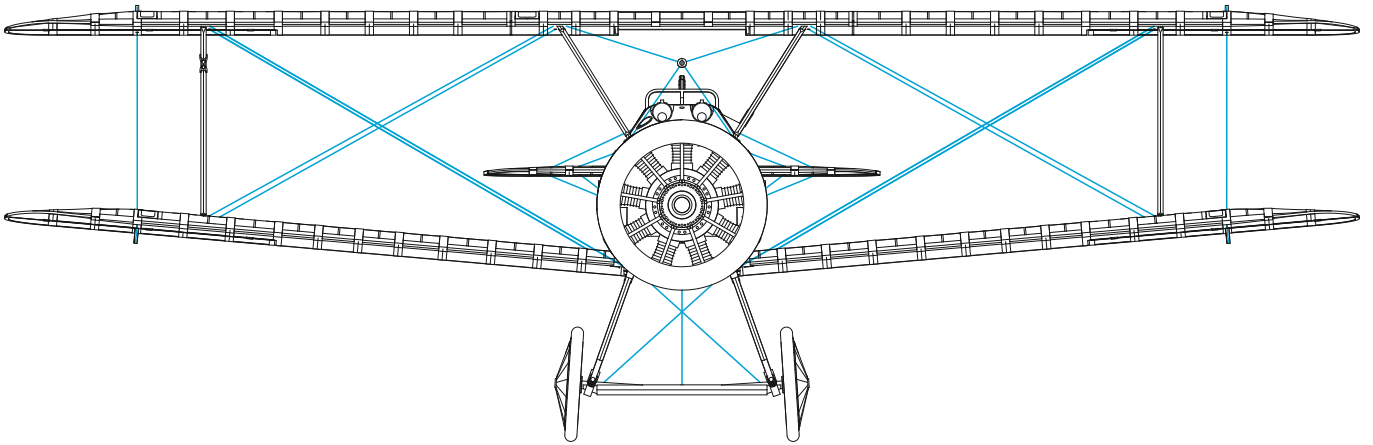

# A J4613, Capt. James Bigglesworth, No. 266 Sqn RFC, March 1917

The author of the Biggles books, W. E. Johns, illustrated his first books himself and, like illustrator Howard Leigh, sometimes depicted British aircraft from the Great War (and not only in the Biggles stories) with blue fuselage and yellow wings. The reason for this may have been that they both were finding the colors of British aircraft too dull, and so were seeking inspiration in the color scheme of the US Army Air Force of the time. In the Biggles books, this paint scheme of the Camel has appeared in several modifications, and we have selected the one that accompanied the book "Biggles of the Camel Squadron", published in 1935 by John Hamilton, Ltd, with, if nothing else, illustrations by Howard Leigh. As with virtually all representations of fictional Camels of a fictional pilot, the serial number is also fictional. There was no J series in the case of the Sopwith Camel production.

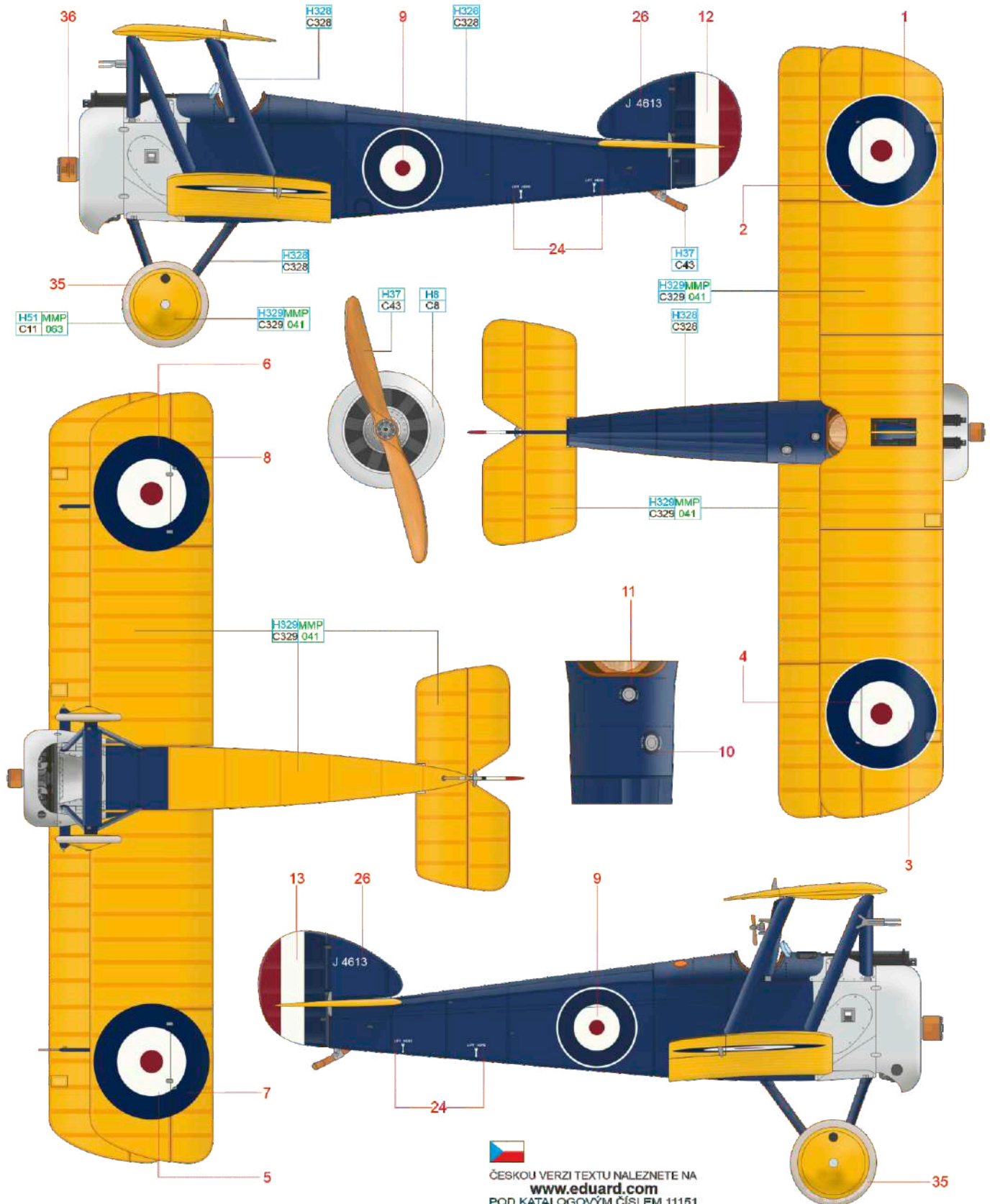

ČESKOU VERZI TEXTU NALEZNETE NA  
[www.eduard.com](http://www.eduard.com)  
 POD KATALOGOVÝM ČÍSLEM 11151

SILVER H8 C8 LIGHT GULL GRAY H51 MMP C11 063 WOOD H37 C43 BLUE H328 C328 YELLOW H329 MMP C329 041

eduard

## B J1936, Capt. James Bigglesworth, No. 266 Sqn RAF, summer 1918

This is a form of the "late" Biggles Camel as described in the short stories "The Fledglings" and "Biggles on the Spot". In both cases we read about letters drawn on the Camel's nose, similar to the practice seen on SE.5a fighters or DH.4s of the No. 55 Squadron IAF. Another clue is that the German pilots identified Biggles' Camel by its blue engine cowling and declared him as a most prominent enemy. The entire squadron painted the nose of their machines blue subsequently. In the latter story, there is also mention of the Bentley engine in Biggles' Camel. The serial number is again fictitious, the individual markings and the squadron markings are white, but the individual lettering on the nose is blue. The color of the upper surfaces is, let's say, PC10.

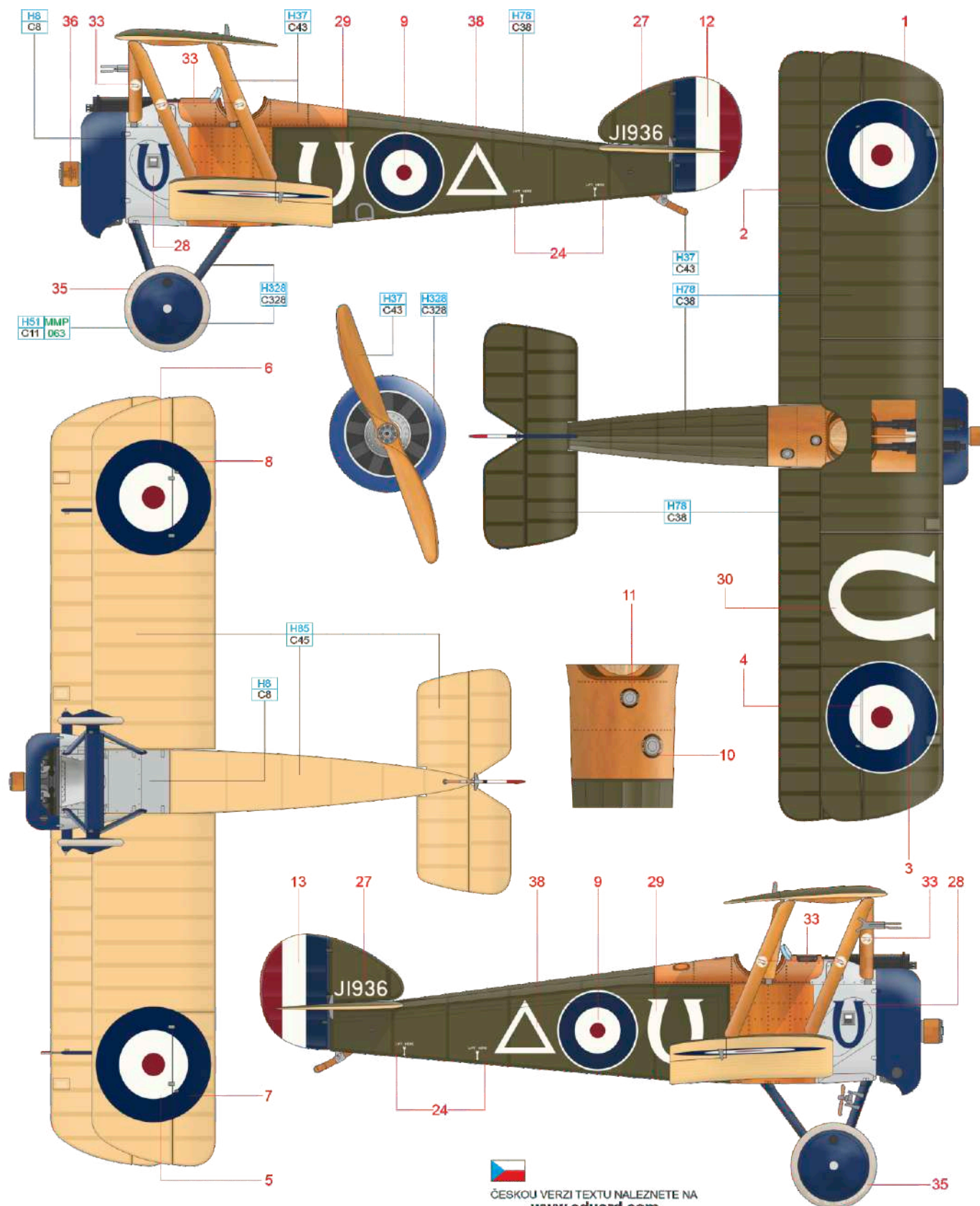

ČESKOU VERZI TEXTU NALEZNETE NA  
[www.eduard.com](http://www.eduard.com)  
 POD KATALOGOVÝM ČÍSLEM 11151

SILVER	H8 C8	LIGHT GULL GRAY	H51 MMP C11 063	WOOD	H37 C43	BLUE	H328 C328	OLIVE DRAB	H78 C38	SAIL COLOR	H85 C45
--------	----------	--------------------	--------------------	------	------------	------	--------------	---------------	------------	---------------	------------

eduard

# C B3889, Capt. Clive F. Collett, B Flight, No. 70 Sqn RFC, Poperinge, Belgium, August 1917

Clive Franklyn Collett was a New Zealand fighter ace with 11 victories. He joined the RFC in the first year of the war, while he underwent pilot training at a private flying school. In January 1915 he obtained his Royal Aero Club license No. 1057 and joined No. 11 Squadron RFC in May 1915. Two months later he was transferred to No. 8 Sqn, then to No. 32 Sqn and in March 1916 to No. 18 Sqn, where he began combat operations with Vickers FB.5. After an injury he returned to Great Britain. On July 24, 1917, he joined No. 70 Sqn, which was the first Squadron to be equipped with Camels. Three days later he achieved his first victory by shooting down an Albatros D.V. He added six kills during August and four more in September. After recuperation from the wound (gunshot of the arm) Collett was posted to No. 73 Sqn. There, on December 23 he took off for a test flight with a captured Albatros, crashed into the sea and was killed. His Camel from the successful period with No. 70 Sqn bore the standard livery with probably PC12 paint on the upper surfaces. The metal and wooden parts of the front fuselage were probably painted in the 'Battle Grey' color. The machine was built by the Sopwith factory and powered by a Clerget engine.

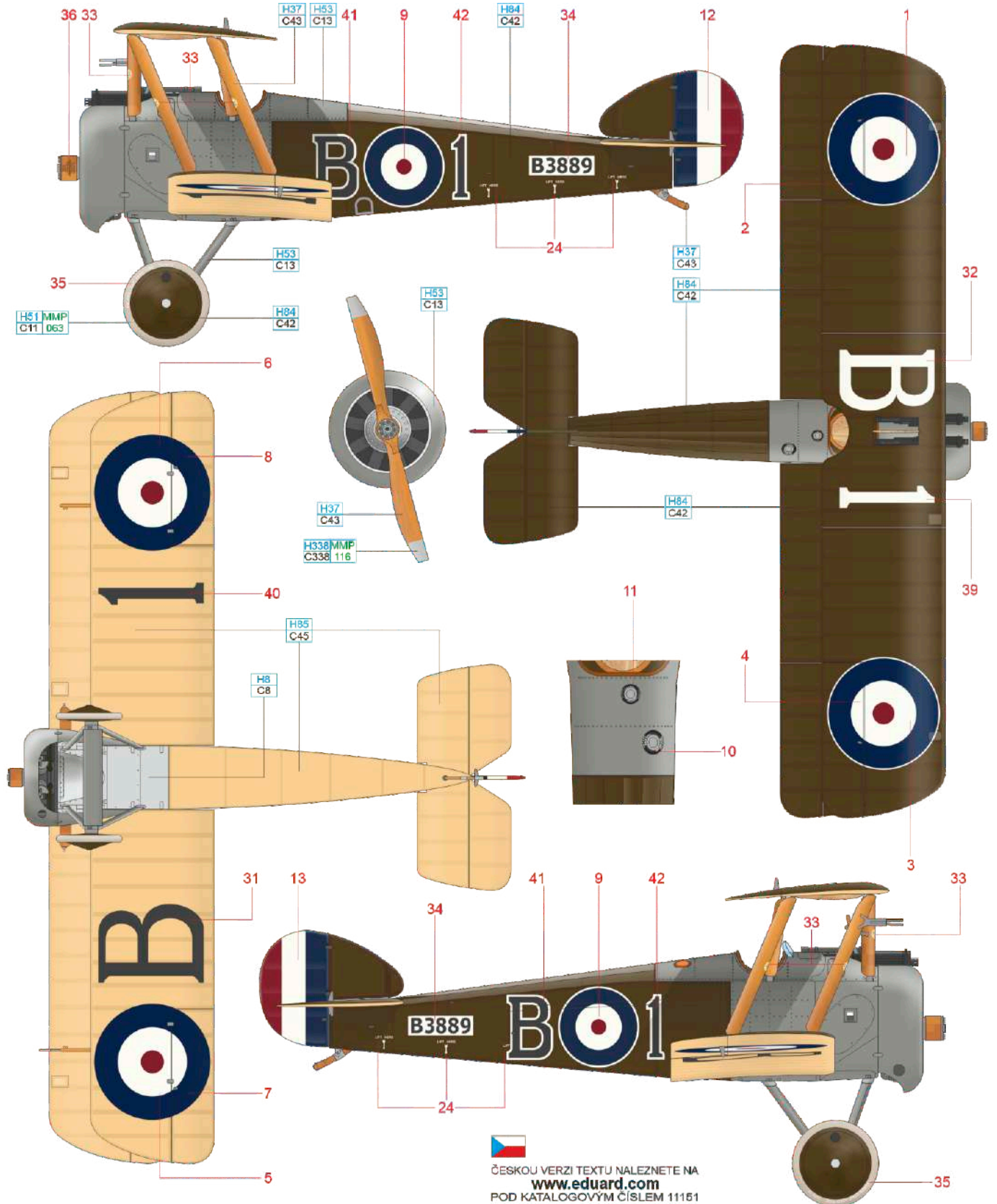

ČESKOU VERZI TEXTU NALEZNETE NA  
[www.eduard.com](http://www.eduard.com)  
 POD KATALOGOVÝM ČÍSLEM 11151

SILVER	H8 C8	LIGHT GULL GRAY	H51 MMP C11 063	NEUTRAL GRAY	H53 C13	LIGHT GRAY	H338 MMP C338 116	WOOD	H37 C43	BLUE	H328 C328	MAHAGONY	H84 C42	SAIL COLOR	H85 C45
--------	----------	--------------------	--------------------	-----------------	------------	---------------	----------------------	------	------------	------	--------------	----------	------------	---------------	------------

# D B7190, Capt. Walter G. R. Hinchliffe, C Flight, No. 10(N) Sqn RNAS, Tétéghem, France, March 1918

"Hinch", as Walter Hinchliffe was called, scored six kills during World War I, all when at controls of a Camel. He shot down his second and third victims on the one of serial number B7190. Hinchliffe served with the artillery at the start of the Great War, only joining the ranks of the RNAS (Royal Navy Air Service) in 1916. He completed his pilot training and served as an instructor at the RNAS base at Cranwell afterwards. There he clocked an incredible 1,250 flight hours in thirteen months. It was not until January 1918 that he joined No. 10 Sqn RNAS. He scored his first kill on February 3 when he shot down an Albatros D.V., his last one occurred on May 19. On June 3 he suffered serious head and facial injuries after a crash and lost his left eye. After the War he flew as an airline pilot. In 1928 he attempted to fly across the Atlantic. He took off from Cranwell Airport on March 13 with co-pilot Elsie Mackay. They have not been seen since... "Hinch's" Camel bore a striking livery with blue and white stripes on the nose and a blue fuselage spine. There was a drawing of a devil on the wheel discs, the German word DONNERWETTER behind the cockpit, possibly on both sides, and a symbol, which was, according to the only known photo of this part of the aircraft, probably stylized combination of the letters W and H on the ridge of the aft fuselage. Upper and sides were probably in PC10 color. Camel B7190 was built by the Clayton & Shuttleworth company and was powered by a Bentley B.R.1 engine.

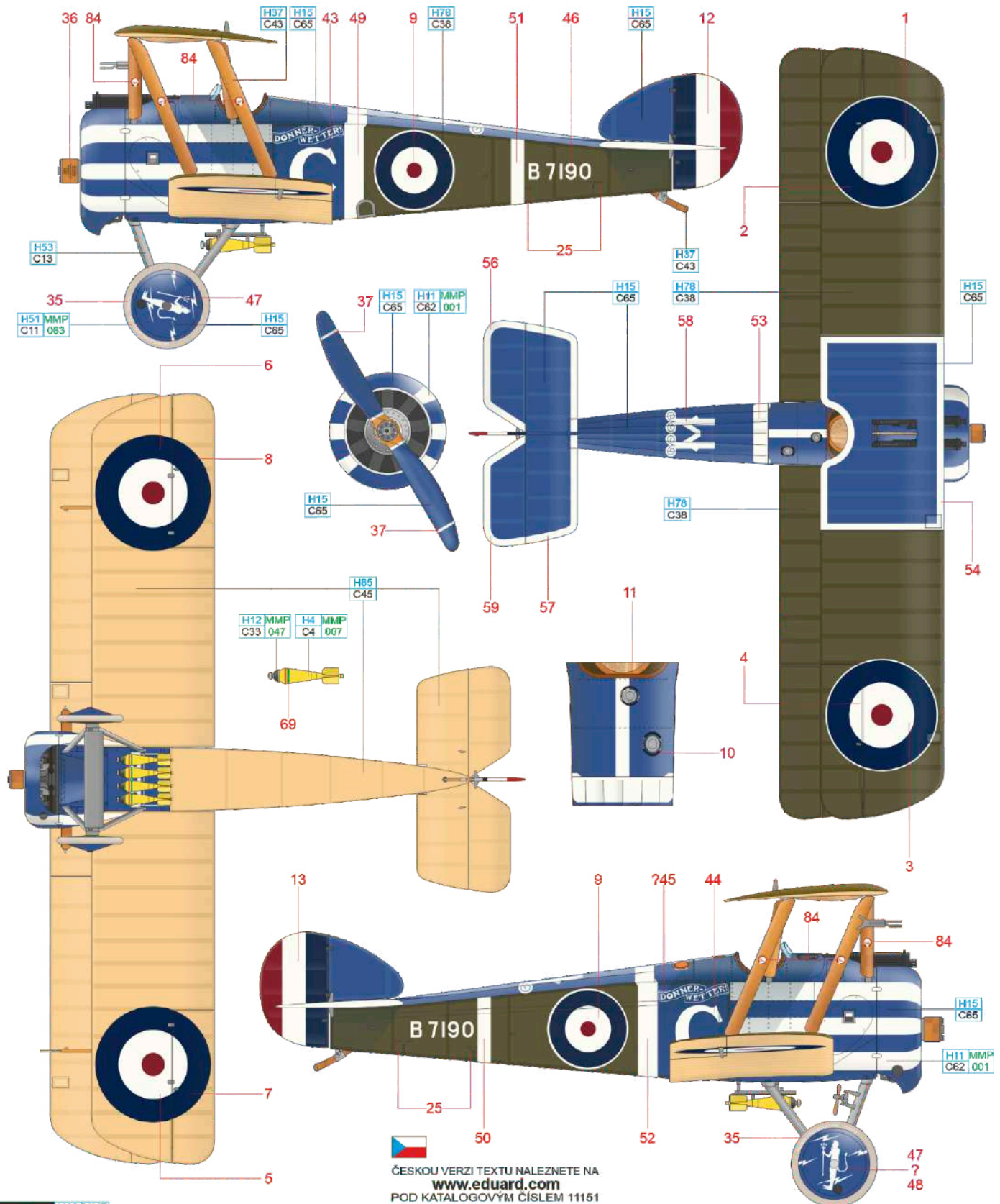

ČESKOU VERZI TEXTU NALEZNETE NA  
[www.eduard.com](http://www.eduard.com)  
 POD KATALOGOVÝM ČÍSLEM 11151

BLACK	H12 MMP C33 047
LIGHT GULL GRAY	H51 MMP C11 063

NEUTRAL GRAY	H53 C13
--------------	---------

WOOD	H37 C43
------	---------

BLUE	H16 C65
------	---------

OLIVE DRAB	H78 C38
------------	---------

SAIL COLOR	H65 C45
------------	---------

WHITE	H11 MMP C62 001
-------	-----------------

YELLOW	H4 MMP C4 007
--------	---------------

eduard

# E B3893, Capt. Arthur R. Brown, No. 9(N) Sqn RNAS, Leffrinckoucke, France, September 1917

Canadian Arthur R. Brown became one of the most famous fighters of the Entente Powers, although he achieved "only" ten kills. The reason is his victory over Manfred von Richthofen. Brown achieved three kills flying this Camel during September and October 1917 (3<sup>rd</sup> to 5<sup>th</sup> kills). Brown became an RNAS pilot on November 24, 1915, but on May 2, 1916, he suffered a back injury in a crash and spent three months recovering. Further health issues prevented him from combat until April 1917, when he was assigned to No. 9(N) Sqn RNAS and changed No. 11 and No. 4 subsequently. When back at No. 11 Sqn, he achieved his first kill on July 17. In September he returned to No. 9 Sqn. By the end of October, he scored five times and, after rest, returned to the unit in February 1918, adding three more victories before spotting a red "Dreidecker" attacking Camel of Lt. May on April 21. He shot the enemy down. As it turned out his victim was the famous "Red Baron". Brown later served as an instructor. On July 15 he fainted during flight, crashed, and suffered serious head injuries. It took five years for him to make a full recovery. Brown died of a heart attack on March 9, 1944. His Camel B3893 was a Sopwith production and had the face of comedian George Robey from the musical "Zig Zag!" drawn on the horizontal stabilizer. Upper and side surfaces were probably in PC12.

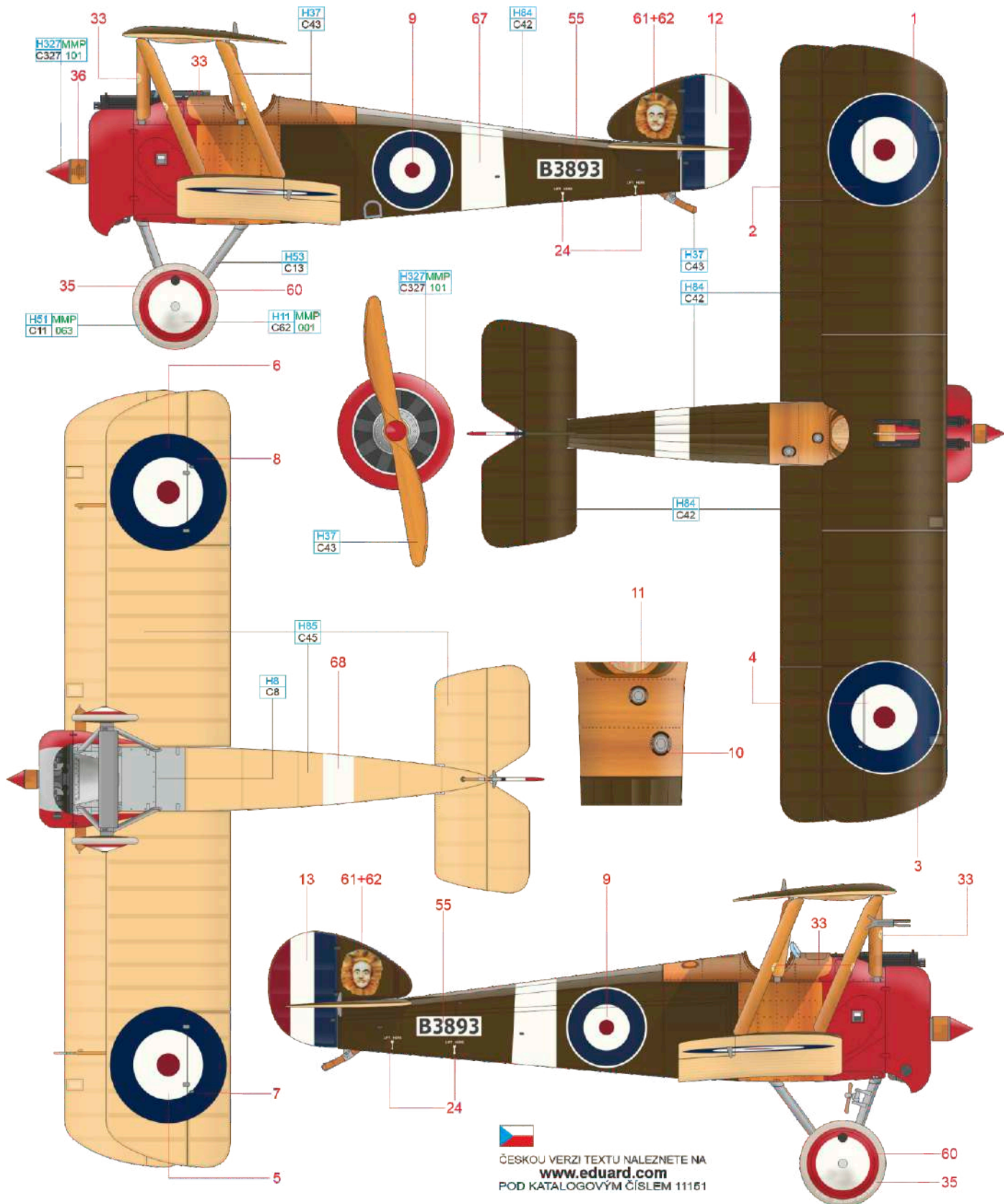

ČESKOU VERZI TEXTU NALEZNETE NA  
[www.eduard.com](http://www.eduard.com)  
 POD KATALOGOVÝM ČÍSLEM 11151

SILVER	H8 C8	LIGHT GULL GRAY	H61 MMP C11 063	NEUTRAL GRAY	H53 C13	WOOD	H37 C43	RED	H327 MMP C327 101	MAHAGONY	H84 C42	SAIL COLOR	H85 C45	WHITE	H11 MMP C62 001
--------	----------	--------------------	--------------------	--------------	------------	------	------------	-----	----------------------	----------	------------	------------	------------	-------	--------------------

# F N6377, Capt. Harold F. Beamish, No. 3(N) Sqn RNAS, Furnes, Belgium, September 1917

New Zealander H. F. Beamish, nicknamed "Kiwi", scored eleven kills in World War I, five of them in cooperation. He joined the RNAS in June 1916 and served with No. 3 Sqn and No. 203 Sqn RAF (when the unit was renamed after a reorganization on April 1) from January 9, 1917, until August 17, 1918. He scored his first kill on April 23, 1917 (Albatros D.III) flying a Sopwith Pup and scored four more ones with this Camel. In the autumn of 1918, he went home on leave to New Zealand and there too the end of the War found him. After the War he farmed, living to the age of 90 years. He died on October 26, 1986. This Camel N6377 was a Sopwith production, powered by a Bentley engine. It bore a drawing of a green tree on its white back, the main color was probably PC12. The aircraft was later shot down on March 6, 1918, but its pilot, S/Cdr R. S. Dallas, was unhurt and the aircraft was also repaired. It was finally lost on April 22, 1918, when 2/Lt W.H. Easty was shot down with it and killed.

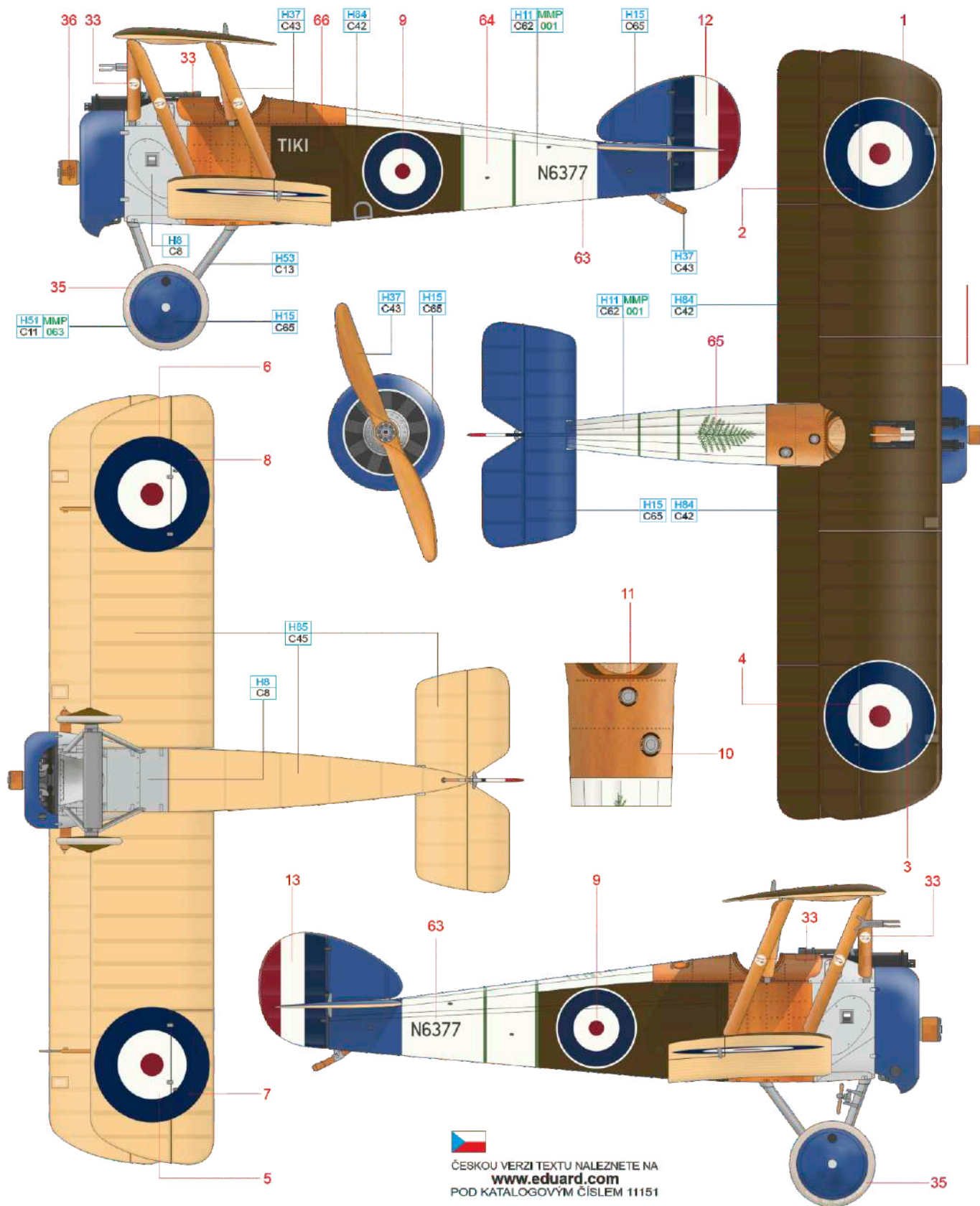

ČESKOU VERZI TEXTU NALEZNETE NA  
[www.eduard.com](http://www.eduard.com)  
 POD KATALOGOVÝM ČÍSLEM 11151

SILVER	H8 C8	LIGHT GULL GRAY	H51 MMP C11 063	NEUTRAL GRAY	H53 C13	WOOD	H37 C43	BLUE	H15 C65	MAHAGONY	H84 C42	SAIL COLOR	H85 C45	WHITE	H11 MMP C62 001
--------	-------	-----------------	-----------------	--------------	---------	------	---------	------	---------	----------	---------	------------	---------	-------	-----------------



Henry Robinson Clay was an American ace with eight victories, and a member of the first contingent of American pilots sent to gain experience in RFC service. He was assigned to No. 43 Sqn and claimed his first victory in its ranks, but it remained unconfirmed. He was then transferred to the 148<sup>th</sup> Aero Squadron and in the period from August 16 to September 27, 1918, achieved all of his eight victories, this time confirmed. On six occasions his victim was a dangerous opponent, a Fokker D.VII. At the very end of the war, Clay was appointed commander of the 41<sup>st</sup> Aero Squadron, where he flew this Camel of unknown serial number. The unit's emblem was a camel passing through a letter V. Upper and side surfaces were PC10. Before he could lead his unit into combat for the first time, the war was over. But Clay never returned home to the United States. He died in Coblenz, Germany, on February 17, 1919, during the third wave of the Spanish flu.

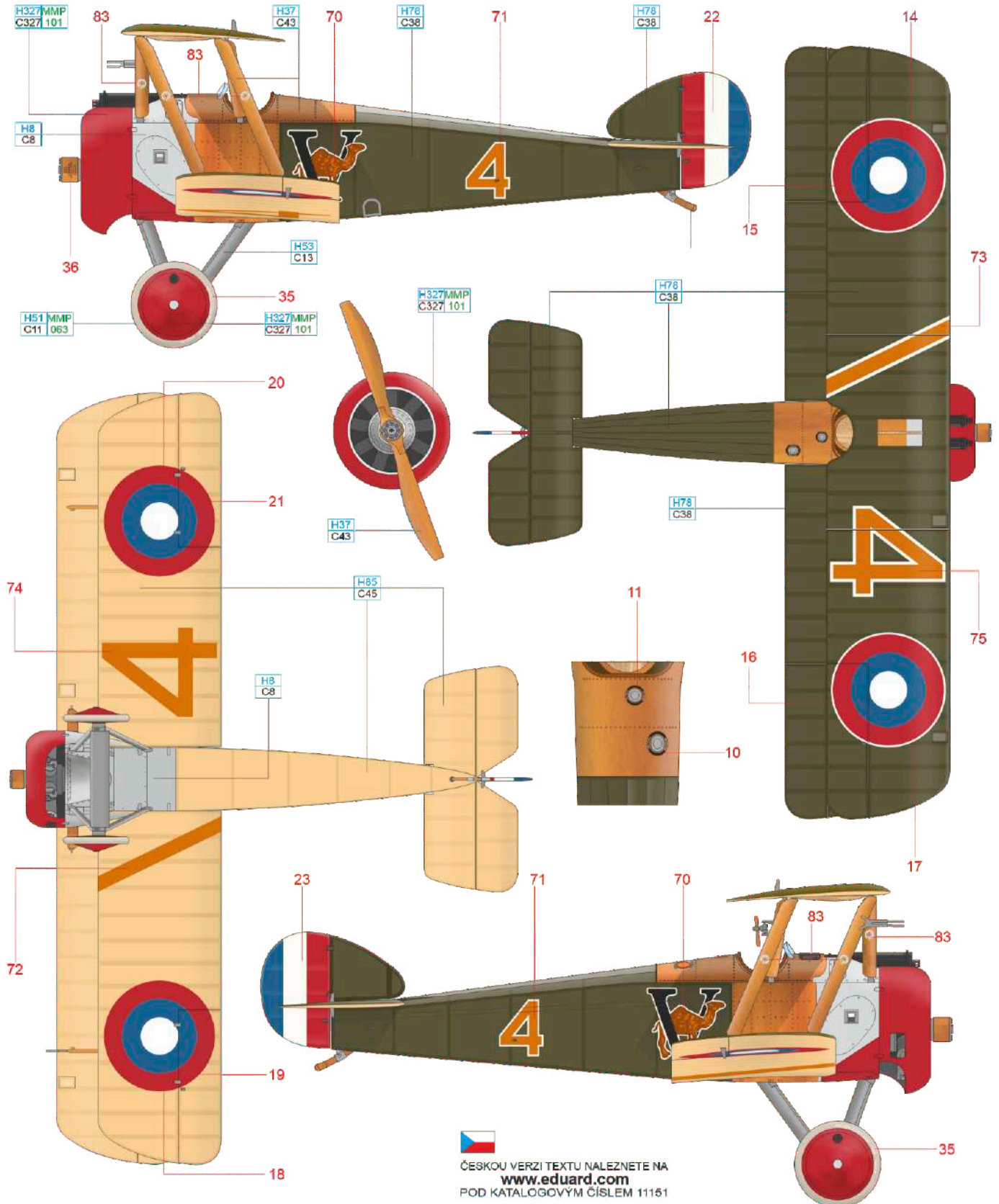

ČESKOU VERZI TEXTU NALEZNETE NA  
**www.eduard.com**  
 POD KATALOGOVÝM ČÍSLEM 11151

SILVER	H8 C8	LIGHT GULL GRAY	H51 MMP C11 063	NEUTRAL GRAY	H53 C13	WOOD	H37 C43	OLIVE DRAB	H78 C38	SAIL COLOR	H85 C45	RED	H327 MMP C327 101
--------	----------	--------------------	--------------------	--------------	------------	------	------------	------------	------------	------------	------------	-----	----------------------

# H C6713, Capt. D'Urban Victor Armstrong, No. 151 Sqn RAF, Crécy-Estrées, France, April

Captain Armstrong got his unusual first name after his hometown, Durban, South Africa. He joined the RFC ranks in 1915 and a year later was assigned to No. 60 Sqn. In its ranks he achieved his first victory on November 9, 1916. He was then sent back to the UK and served with units assigned to the home defence. Firstly during 1917 in the ranks of No. 44 (HD) Sqn, then he became a flight commander with No. 78 (HD) Sqn. Shortly afterwards he returned to the front to No. 151 Sqn, which became the first RAF night fighter unit in France. In its ranks he scored four kills, three of them at night (the first one occurred at 20:35 on June 29, so still in daylight conditions). Armstrong became a renowned acrobat, and liked to perform his Camel at low altitudes, which later proved fatal to him. Just two days after the end of the war, on November 13, 1918, he performed low-altitude aerobatics near Bouvincourt, crashed and died. His red Camel C6713 sported the name Doris and flew in this form before being sent to the front and adapted for night missions by overpainting white fields in the wing cockades and deletion of the fuselage cockades. Also, the lights were added. The C6713 was produced by British Caudron company and powered by a LeRhone 9J engine.

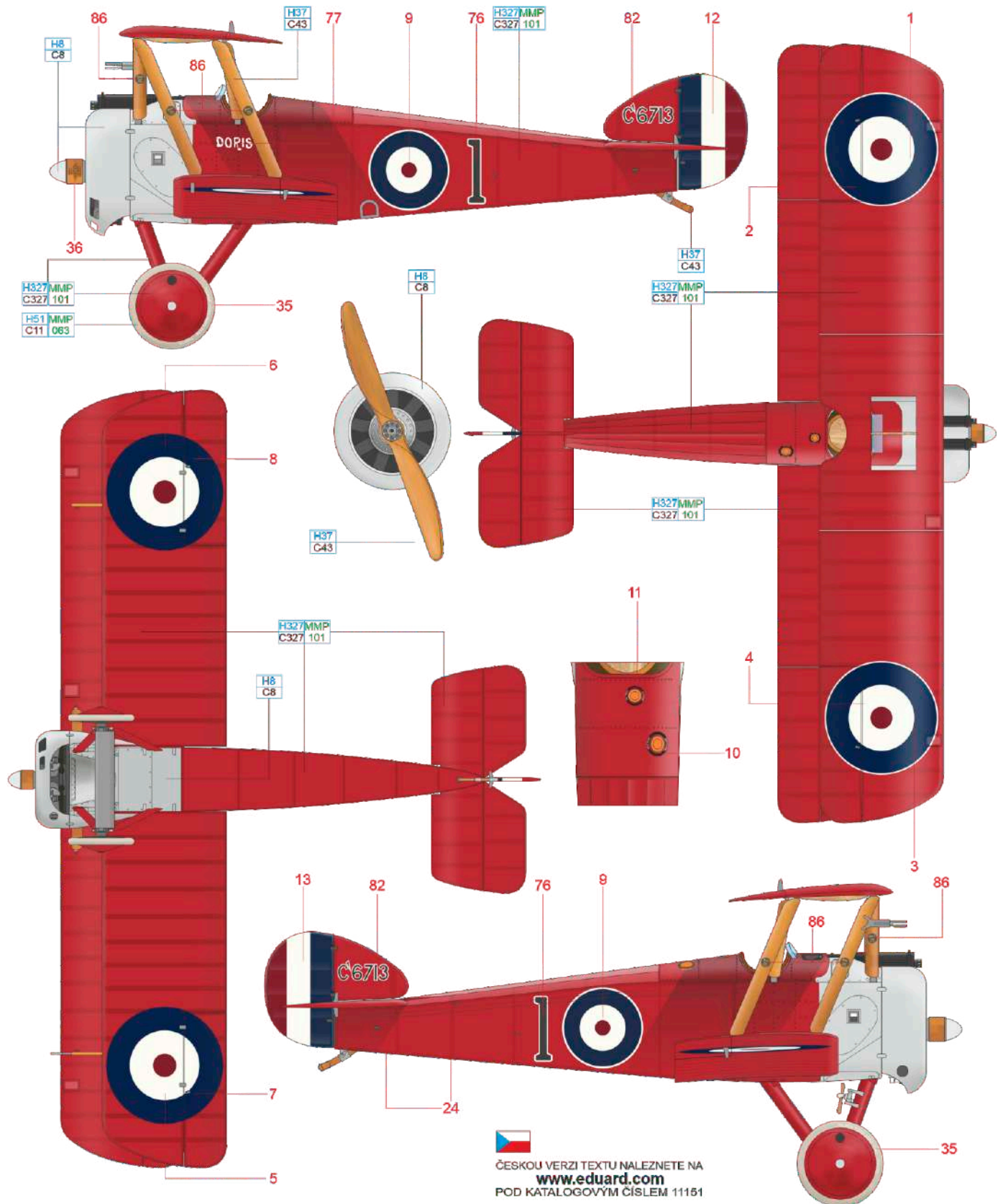

ČESKOU VERZI TEXTU NALEZNETE NA  
[www.eduard.com](http://www.eduard.com)  
 POD KATALOGOVÝM ČÍSLEM 11151

SILVER H8 C8 LIGHT GULL GRAY H61 MMP C11 063 WOOD H37 C43 RED H327 MMP C327 101

eduard

# C1555, Capt. Francis L. Luxmoore, No. 78(HD) Sqn RFC, Hornchurch, Great Britain, January 1918

A pilot with three kills to his credit, Francis L. Luxmoore was an aviation enthusiast and wanted to join the RFC as soon as possible after its formation. He did succeed in 1916, and from August that year served in the ranks of No. 46 Sqn. He had to wait until June 4, 1917 for his first victory, when, after separating from the rest of the patrol, he was attacked by a trio of Albatroses and shot down one of them in the ensuing battle. After being sent back to the Great Britain, he served with No. 78(HD) Sqn, flying this Camel equipped with lights for night flying. He then returned to the front with No. 54 Sqn after a rest. In its ranks he shot down another Albatros on February 18, 1918 and scored a third kill on March 13, 1918. Five days later he took part in a dogfight involving more than ninety aircraft, his Camel was damaged in the fight, Luxmoore had to make an emergency landing and was taken POW. After the war, he remained in the RAF ranks until 1928 and stayed in touch with aviation industry. His Camel from the period of service with No. 78(HD) Sqn sported a coat of azure blue paint on the canvas fuselage parts and on upper wing surfaces. Luxmoore did not achieve any kills with it. It was a Hooper production Camel and was powered by a LeRhone.

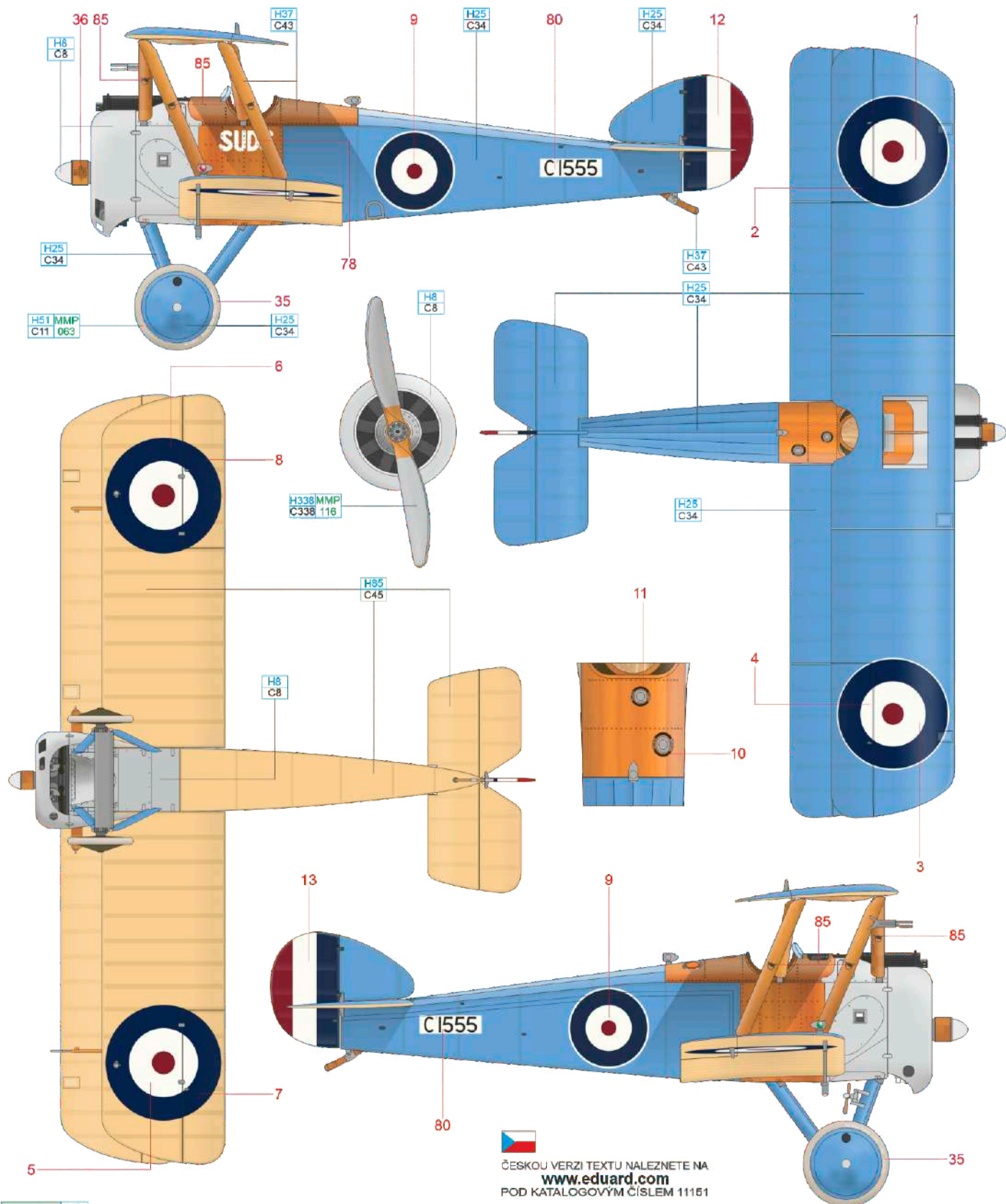

ČESKOU VERZI TEXTU NALEZNETE NA  
[www.eduard.com](http://www.eduard.com)  
 POD KATALOGOVÝM ČÍSLEM 11151

SILVER	H8 C8	LIGHT GULL GRAY	H51 MMP C11 063	WOOD	H37 C43	BLUE	H25 C34	SAIL COLOR	H85 C45
--------	----------	--------------------	--------------------	------	------------	------	------------	---------------	------------

# J F1471, 185<sup>th</sup> Aero Sqn USAS, Colombey-les-Belles, France, March 1919

The 185<sup>th</sup> Aero Squadron of USAAC was established on November 11, 1917, at Kelly Field, Texas, by transferring some personnel from the 24<sup>th</sup> Aero Squadron. The entire unit then embarked aboard the RMS Adriatic in late January 1918 and arrived in Liverpool on February 16. After the personnel undergo training, they moved to France on August 12 to the American Rest Camp No. 2 at Le Havre. From there they proceeded to St. Maxient Replacement Barracks for ground training and then to Colombey-les-Belles for further aerial training. However, due to the need to resupply other units, seventeen pilots with completed training were transferred elsewhere. The 185<sup>th</sup> Aero Squadron itself did not receive its Camels until September 12 after moving to Rembercourt airfield. At the same time, it was the first U.S. unit designated for night fighter duty. However, the pilots were not trained for such a task, nor did the equipment of the airfield and aircraft were sufficient for it. This Camel was delivered to the unit two days after the Armistice and remained in the unit's inventory even after it moved back to Colombey-les-Belles and changed their Camels for Spads XIII in February 1919. This Camel received a coat of white paint on the fuselage during this period. Upper sides of wings remained in PC10. The squadron emblem, a black bat in an orange circle, was painted on the aircraft after the war. The F1471 Camel was manufactured by Boulton & Paul and was powered by a Gnome engine.

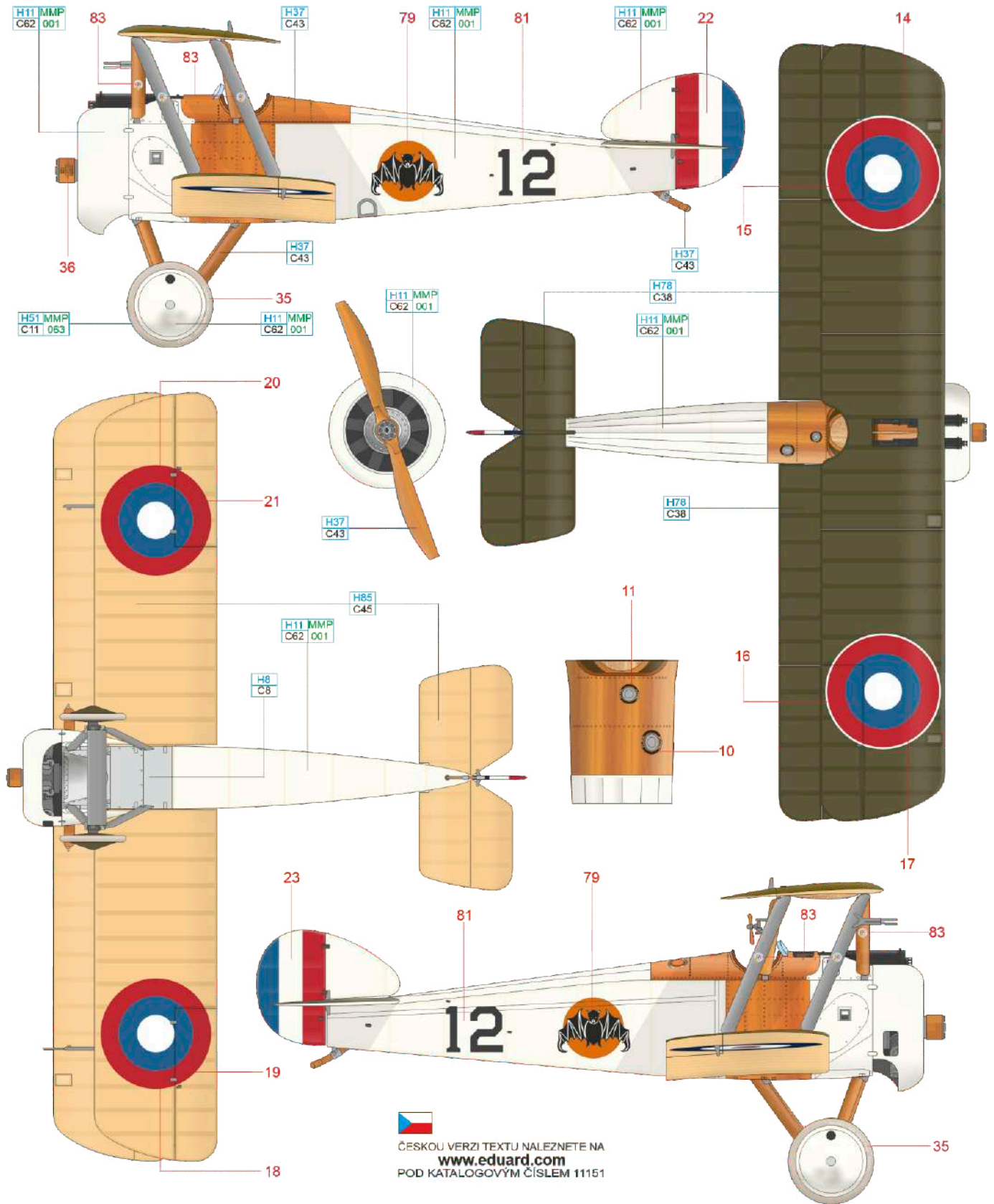

SILVER H8 C8 LIGHT GULL GRAY H51 MMP C11 063 NEUTRAL GRAY H53 C13 WOOD H37 C43 OLIVE DRAB H78 C38 SAIL COLOR H85 C45 WHITE H11 MMP C62 001

eduard