

Z-37A Čmelák

eduard

1/72 Scale Plastic Model Kit

WEEKEND
edition



item No. 7456

Aerial crop dusting is a very challenging kind of flying and needs specialised aircraft to be both effective and safe. Czechoslovak design Z-37A Čmelák is surely such an aircraft.

Agricultural use of the aircraft became a common practice after the WWII, as many suitable aircraft have been available and the aerial spreading or spraying of fertilizers, seeds, or pesticides was found quite effective. It was no wonder the aircraft manufacturers were finally asked to build agricultural specials to get even more efficiency. Representatives of the countries of the CMEA (Council for Mutual Economic Assistance) organization uniting the states of the former Soviet bloc, also set requirements for the development of an agricultural aircraft to be used by all CMEA member countries. The development was assigned to Czechoslovakia in 1960. The new aircraft had to take off and land on very short unpaved areas and it also had to have good handling when flying at minimum altitudes of about 16 ft (5 m) above the ground. The design also needed to be very tough, resistant to rough handling and wear due to high numbers of takeoffs and landings. At the same time, the aircraft had to be easy to maintain and resistant to various chemicals.

Birth of the Bumblebee

Two companies supplied the committee with their preliminary designs. The first, Středočeské strojírný (formerly Letov) prepared the design of the XZ-36, the second, Moravan Otrokovice, developed the XZ-37 design. The latter was chosen as the winner and the design team of Let Kunovice also took part in the development, tasked with the wing design. Due to the nature of typical operations, great attention was paid to the flight characteristics at stall speeds. As the stall performance was found unsatisfactory, fixed slots on outer parts of the leading edge and in front of the flaps brought performance to an acceptable level. The design team led by Svatopluk Zámečník and Miroslav Langer intended to use a new in-line M-441 engine, which was still in development at the time. However, the project was cancelled, so it was necessary to find a replacement. The designers chose a version of the Soviet nine-cylinder radial Ivchenko AI-14 R with compressed air start-up system. However, its power was insufficient. The Avia factory solved the problem with modification, resulting in M-462RF with take-off power of 311 HP (232 kW), which had valuable 51 HP (38 kW) more than the original engine. The engine is driving hydraulically operated constant speed V-520 propeller. Ten prototypes were manufactured under the leadership of Stanislav Sklenář to verify and tune the design thoroughly. Factory pilot Vladimír Vlč took the Z-37 to the air for the very first time on June 29, 1963, conducting a ten-minute flight. Serial production began in 1965 and was divided between three companies. The fuselage, including the application equipment, was produced by Moravan Otrokovice, the wings and tail surfaces were by Let Kunovice and the undercarriage was manufactured by Technometra Radotín. The final assembly took place in Kunovice. From 1971 until 1977, when production ceased, an improved version of the Z-37A was produced with more effective corrosion protection. In total,

about 700 Bumblebees were produced. The production was resumed between 1983 and 1984, when 40 aircraft were produced. Number of Bumblebees were exported, most of them were delivered to the former GDR (about 250).

Tough and durable

The designers paid great attention to the performance characteristics of the aircraft with the maximum load while making some effort to create a comfortable environment for the pilot. The cockpit had ventilation and heating, and air was supplied to it through a carbon filter to prevent the penetration of chemical application substances into the cockpit. To achieve the best possible view the cabin position was in line with leading edge of the wing. To increase safety, an emergency discharge of the spreader and the load in the tank was incorporated. Emergency ejection was carried out during pilot training, with water instead of the chemicals used. Another area that the design team paid attention to, was the protection of the aircraft against corrosion and the effects of chemicals. For this reason, a solid Terylene canvas was used to cover the tubular structure of the fuselage and tail surfaces. In addition, it was provided with a very durable polyurethane coating. The wing was designed as all-metal with a cover reinforced by longitudinal bracing. The wing has very efficient flaps which, even in the closed position, create an increase in lift due to the offset from the wing profile. The free space behind the chemicals tank was called the „sulk room“ and was usually used for transportation of mechanic with his necessary tools from the base to the operating area. He was sitting back to the direction of flight and between him and the pilot was a chemical tank and a rubberized canvas screen. The „sulk room“ also served for the occasional unofficial „sightseeing flight.“

In the middle of nowhere

In the past, most agricultural aircraft in former Czechoslovakia were operated by Slov-Air company, which was also responsible for proper pilot training. The pilots spent whole days in the cabin and were often pushed hard by an agriculturalist that ordered their service. The maximum allowable 80 take-offs per day was often exceeded, with over one hundred take-offs per day not unusual. The cabin did not have air conditioning and, despite the air filtration, chemicals from the sprays usually found their way into cockpit. As the crews and their planes are usually staying all working day somewhere “in the middle of nowhere” without aviation fuel supply, the Z-37 can carry two underwing tanks. They are nothing more but the streamlined barrels to be removed from the aircraft after landing at the field aerodrome. The mechanic than pumps fuel from them into the plane using a hand pump. Each external tank has a volume of 27,5 UK gal (125 l), which doubles the fuel supply, as there are two inner tanks in Z-37, each of the same volume.



Carefully read instruction sheet before assembling. When you use glue or paint, do not use near open flame and use in well ventilated room. Keep out of reach of small children. Children must not be allowed to suck any part, or pull vinyl bag over the head.



Před započatím stavby si pečlivě prostudujte stavební návod. Při používání barev a lepidel pracujte v dobře větrané místnosti. Lepidla ani barvy nepoužívejte v blízkosti otevřeného ohně. Model není určen malým dětem, mohlo by dojít k požití drobných dílů.

INSTRUCTION SIGNS * INSTR. SYMBOLS * INSTRUKTION SINNBILDEN * SYMBOLES * 記号の説明



OPTIONAL
VOLBA



BEND
OHNOU



SAND
BROUSIT



OPEN HOLE
VYVRTAT OTVOR



SYMETRICAL ASSEMBLY
SYMETRICKÁ MONTÁŽ



REMOVE
ODRÍZNOUT



REVERSE SIDE
OTOČIT



APPLY EDUARD MASK
AND PAINT
POUŽÍT EDUARD MASK
NABARVIT

PARTS



DÍLY



TEILE



PIÈCES



部品

PLASTIC PARTS

A>

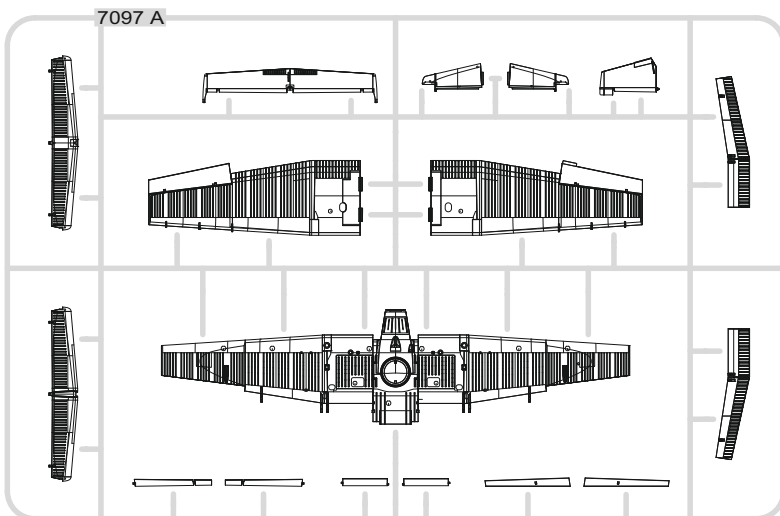

C>

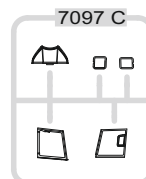

B>

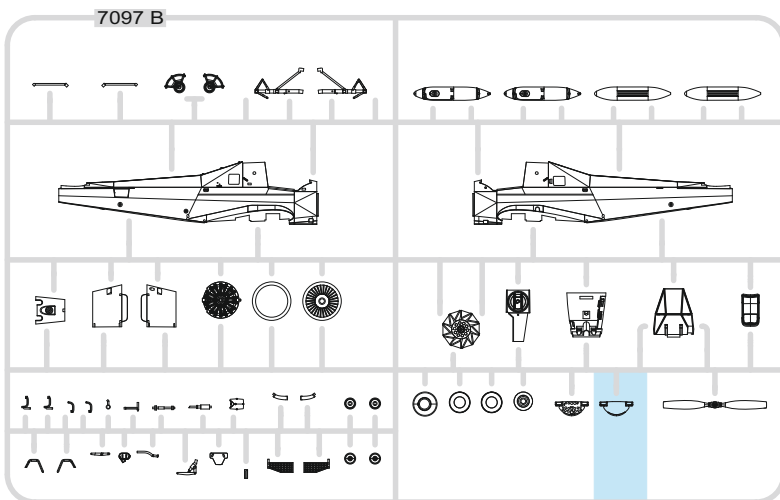

-Parts not for use. -Teile werden nicht verwendet. -Pièces à ne pas utiliser. -Tyto díly nepoužívejte při stavbě. - 使用しない部品

COLOURS



BARVY



FARBEN



PEINTURE



色

GSI Creos (GUNZE)		MISSION MODELS	
AQUEOUS	Mr.COLOR	PAINTS	
[H8]	C8		SILVER
[H11]	C62	[MMP-001]	FLAT WHITE
[H12]	C33	[MMP-047]	FLAT BLACK
[H13]	C3	[MMP-003]	FLAT RED
[H47]	C41	[MMP-012]	RED BROWN
[H63]	C57		METALLIC BLUE GREEN
[H70]	C60	[MMP-056]	GRAY
[H77]	C137	[MMP-040]	TIRE BLACK
[H85]	C45		SAIL COLOR
[H305]	C305	[MMP-084]	GRAY
[H307]	C307	[MMP-074]	GRAY
[H308]	C308	[MMP-073]	GRAY

GSI Creos (GUNZE)		MISSION MODELS	
AQUEOUS	Mr.COLOR	PAINTS	
[H327]	C327	[MMP-101]	RED
[H328]	C328		BLUE
[H336]	C336		HEMP
[H413]	C113	[MMP-090]	YELLOW
[H423]	C123	[MMP-054]	DARK GREEN
	[C56]		IJN GRAY GREEN
Mr.METAL COLOR		METALLICS	
	[MC214]	[MMM-001]	DARK IRON
Mr.COLOR SUPER METALLIC		METALLICS	
	[SM201]	[MMC-001]	SUPER FINE SILVER 2
	[SM203]	[MMC-001]	SUPER IRON 2
	[SM206]	[MMC-001]	SUPER CHROME SILVER 2

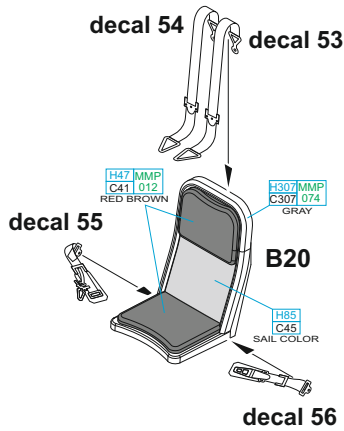
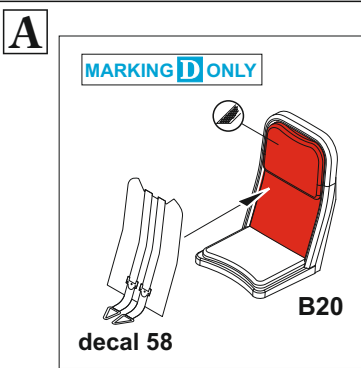

1 =

- H83 C57 BLUE GREEN - MARKING A
- H307 MMP C307 074 GRAY - MARKINGS B; C
- H307 MMP C307 074 GRAY - MARKING D

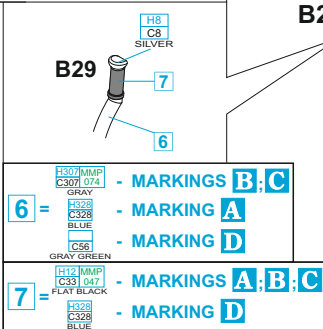
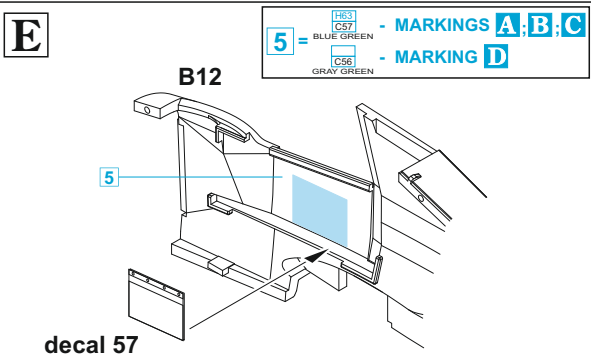
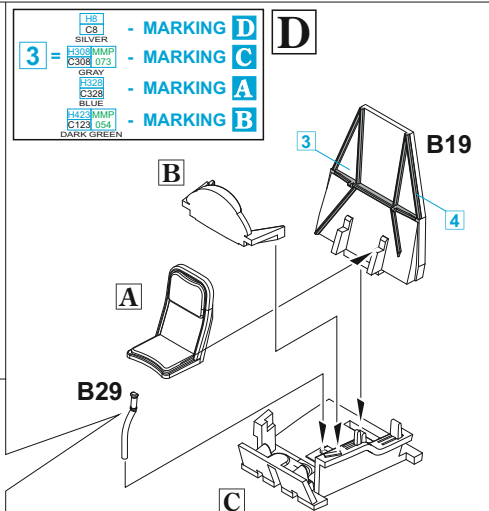
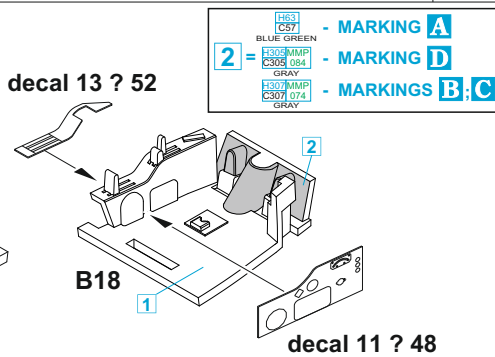
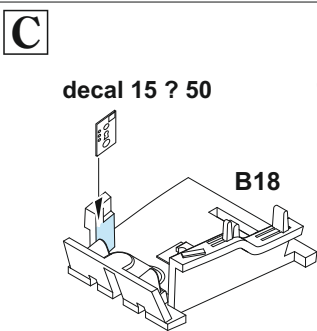
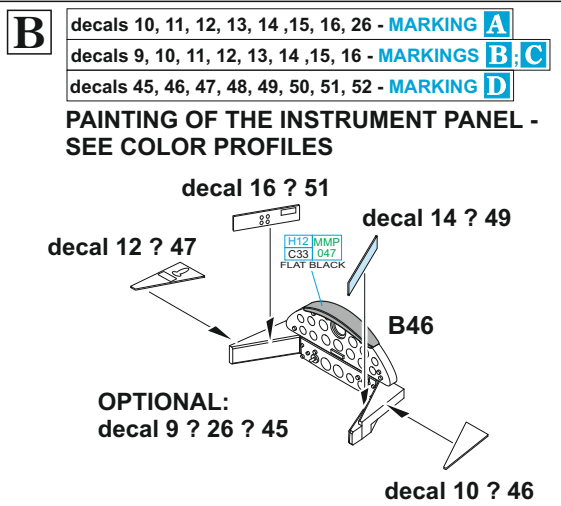

4 =

- H20 MMP C60 056 GRAY - MARKING A
- H307 MMP C307 074 GRAY - MARKINGS B; C; D

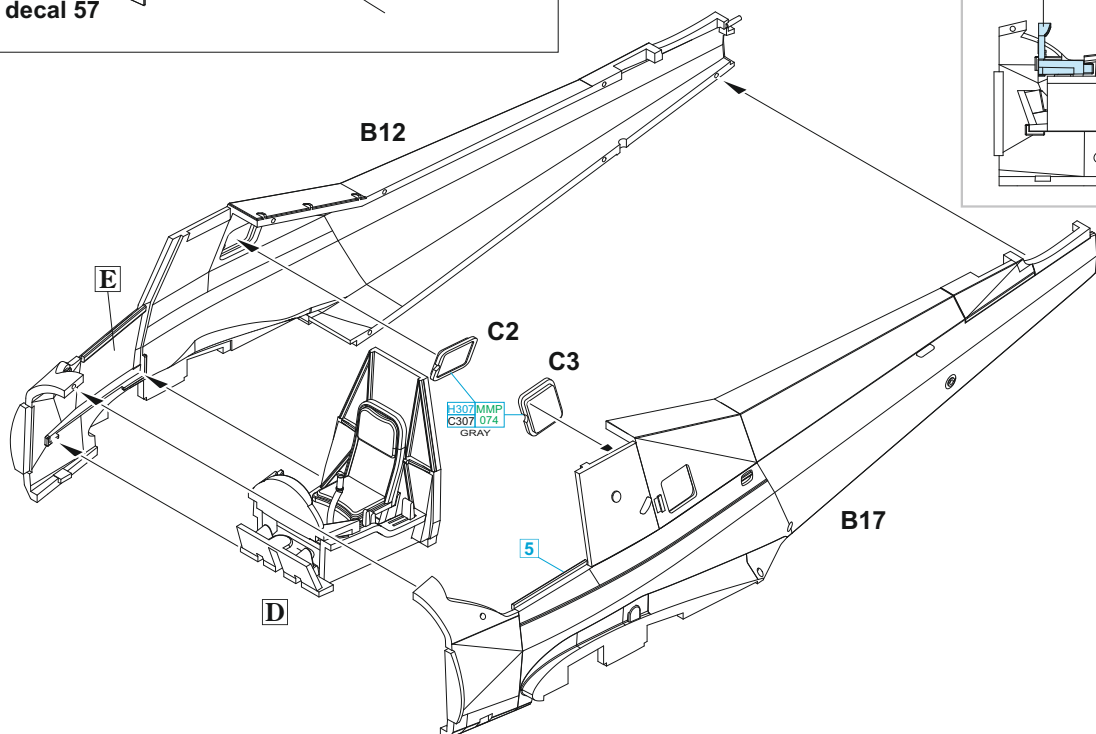
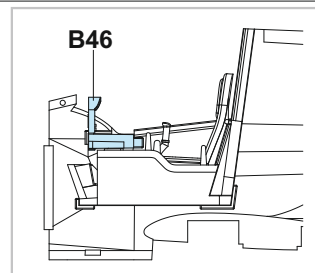

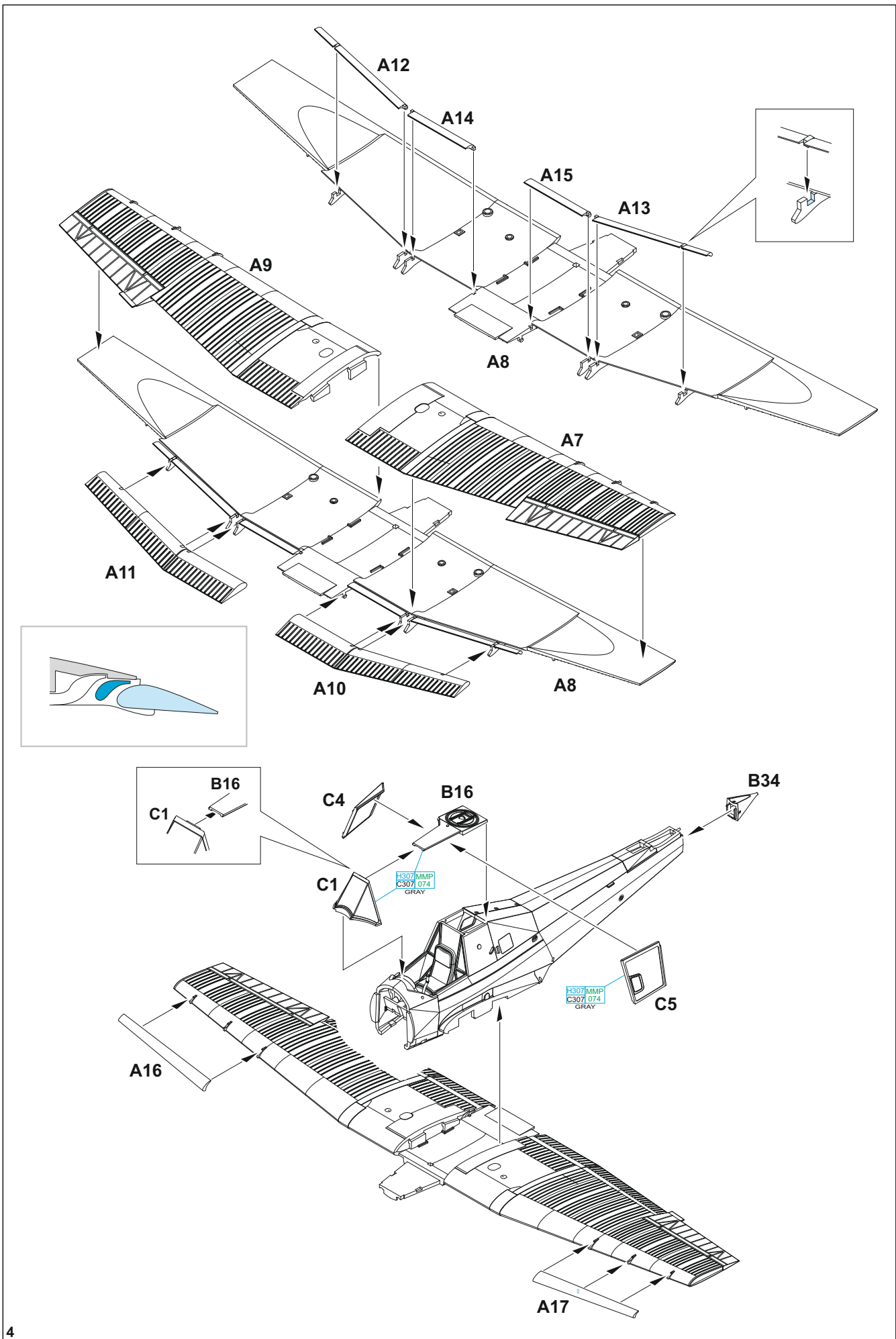

B10

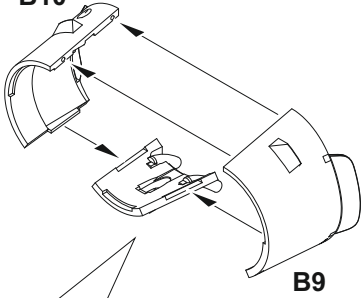

B9

G

SM203
MMC
001
SUPER IRON

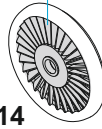

B14

?

B13, B45 - MARKING
D ONLY

B13

H413MMP
C113 090
YELLOW

B45

B11

SM203
SUPER IRON

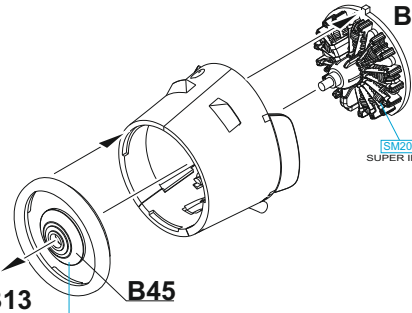

B9 B10

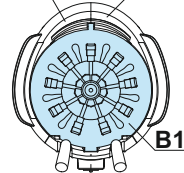

B11

B8

REAR VIEW
POHLED ZEZADU

MC214
MMM
001
DARK IRON

B37

B38

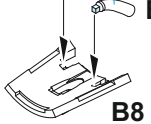

B8

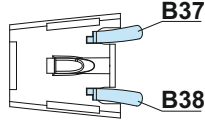

B37

B38

F

A2

A3

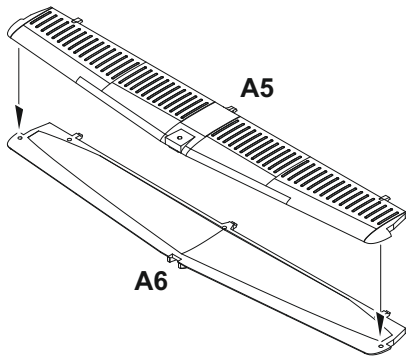
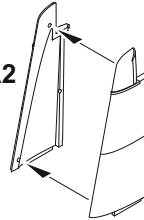

A5

A6

A4

A1

F

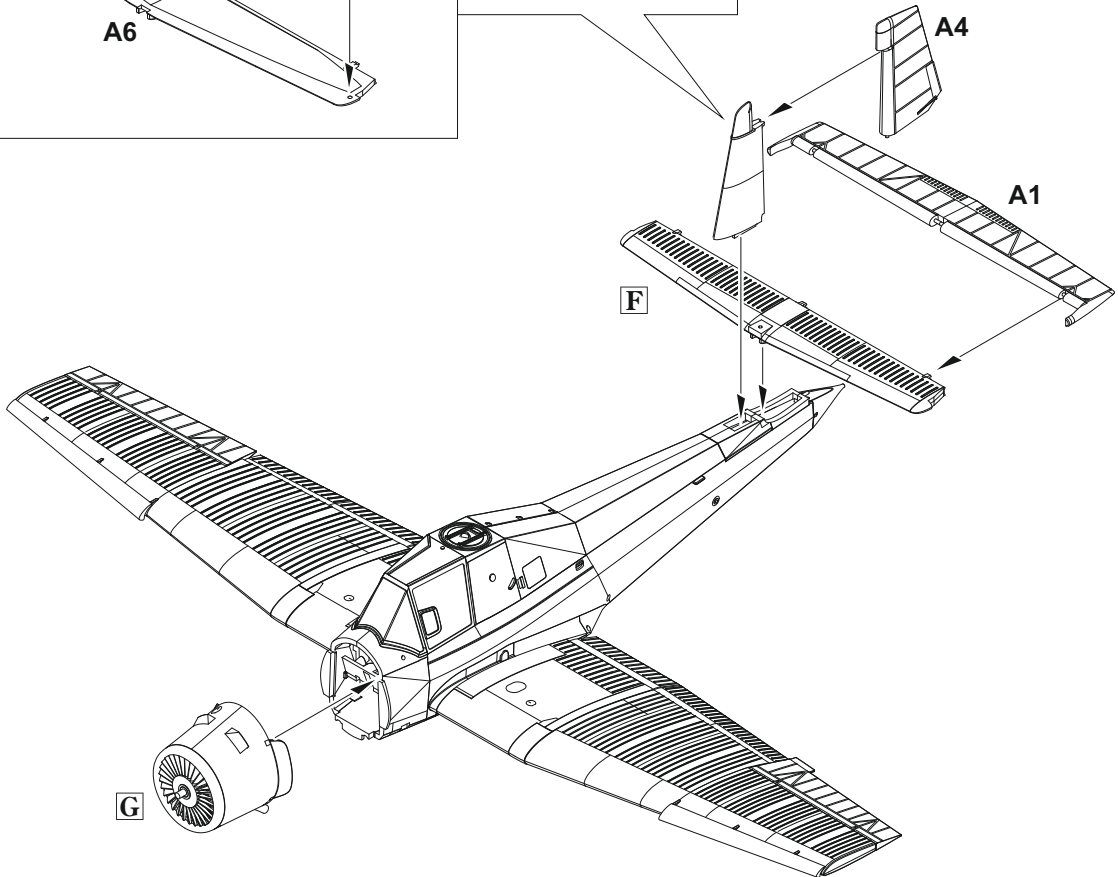

G

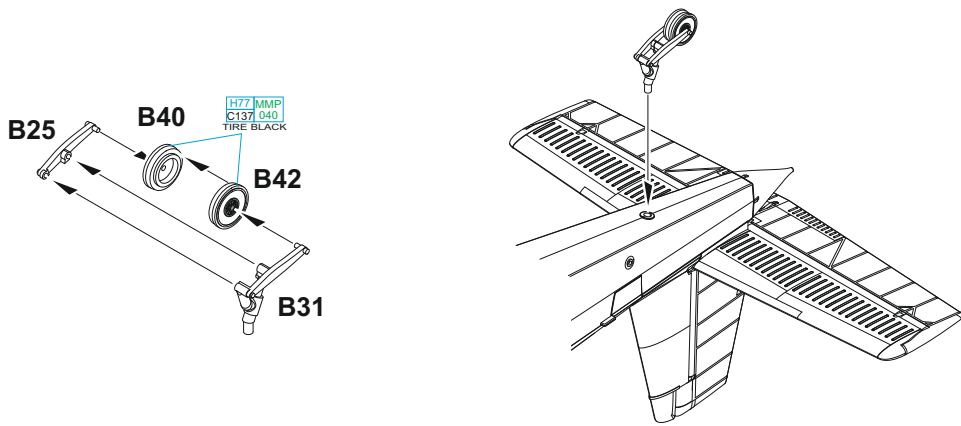

H

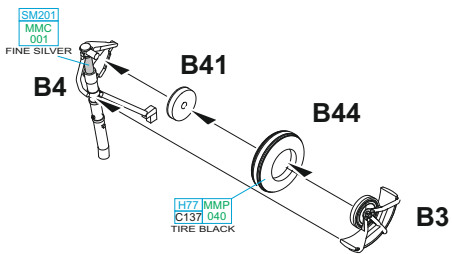

I

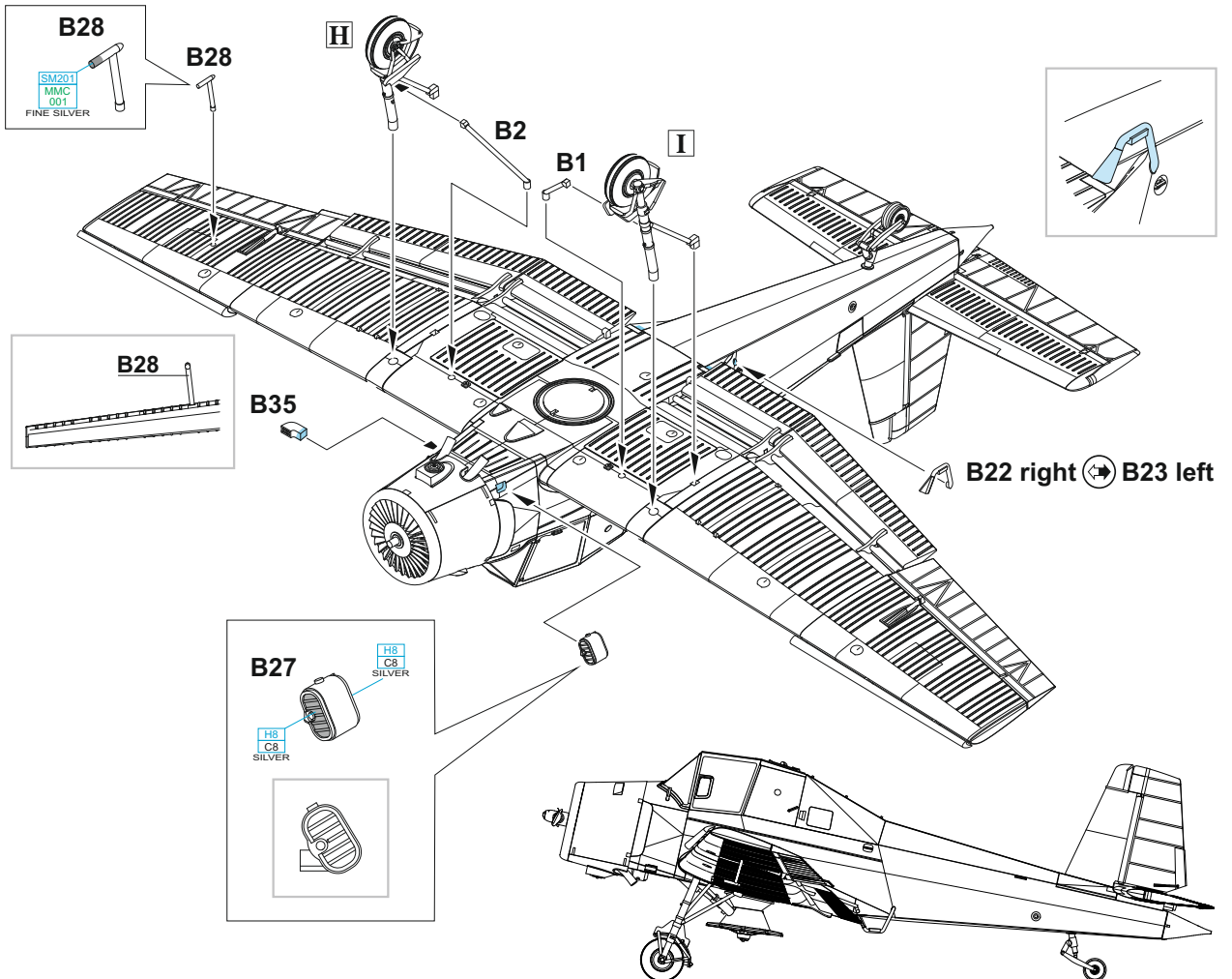
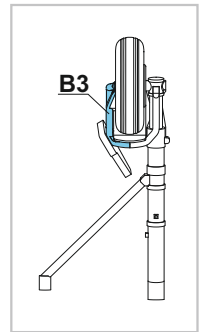
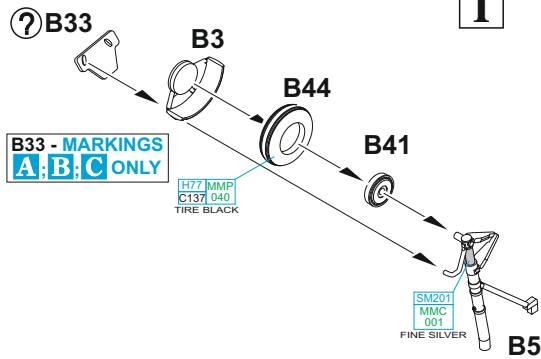

?

2 pcs.

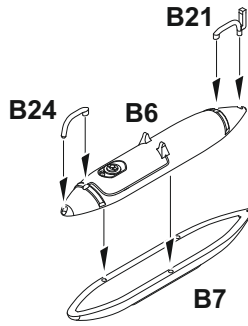

?

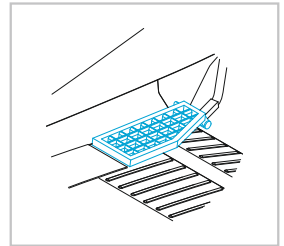
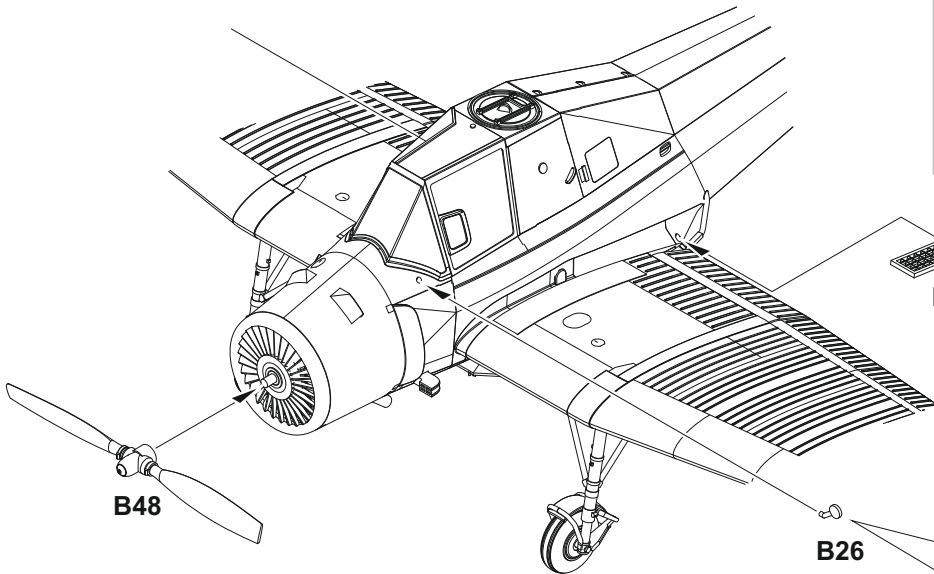
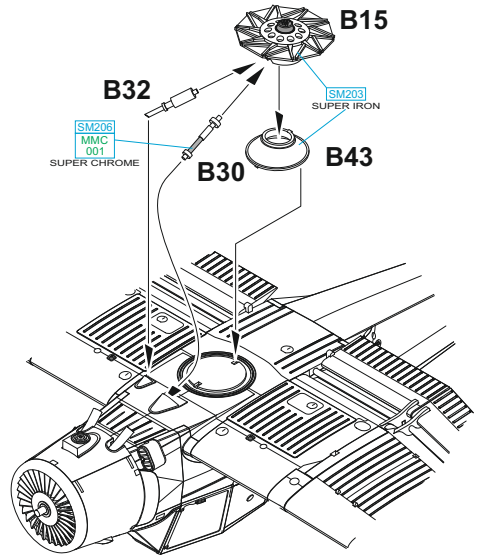
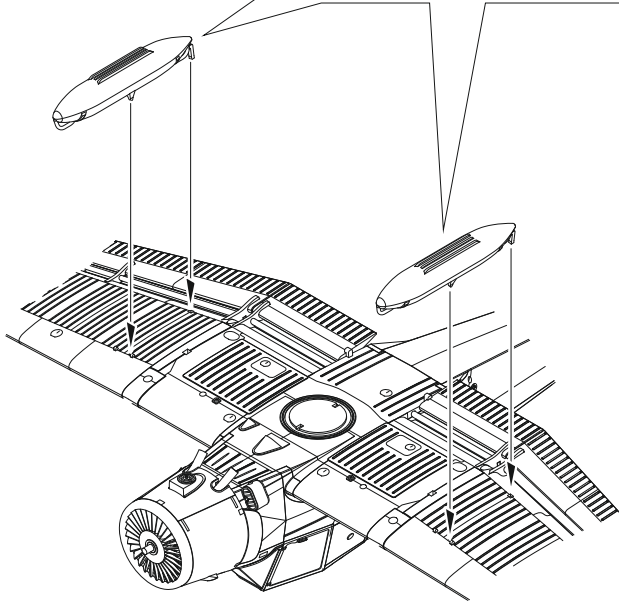
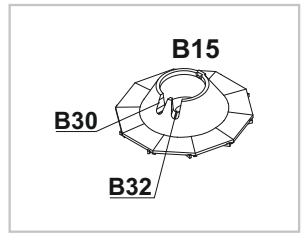

B39 left ? ↔ B36 right

B39 - MARKING **C** ONLY

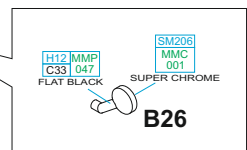

A OK-AKP

Z-37A serial number 12-18, manufactured and registered to Slov-Air in the Slovak Air Register in 1971. After many changes in ownership, the aircraft is currently owned by Air Jihlava - service s.r.o.. The No.310 Squadron RAF badge on the engine cowling and the kill markings under the cockpit are consistent with these items painted on Spitfire Mk.XVI TE184, when it was flown as DU-N. OK-AKP was flown with tiger motif fuel tanks. The plane was stricken off charge in 2018 and became a source for spare parts.

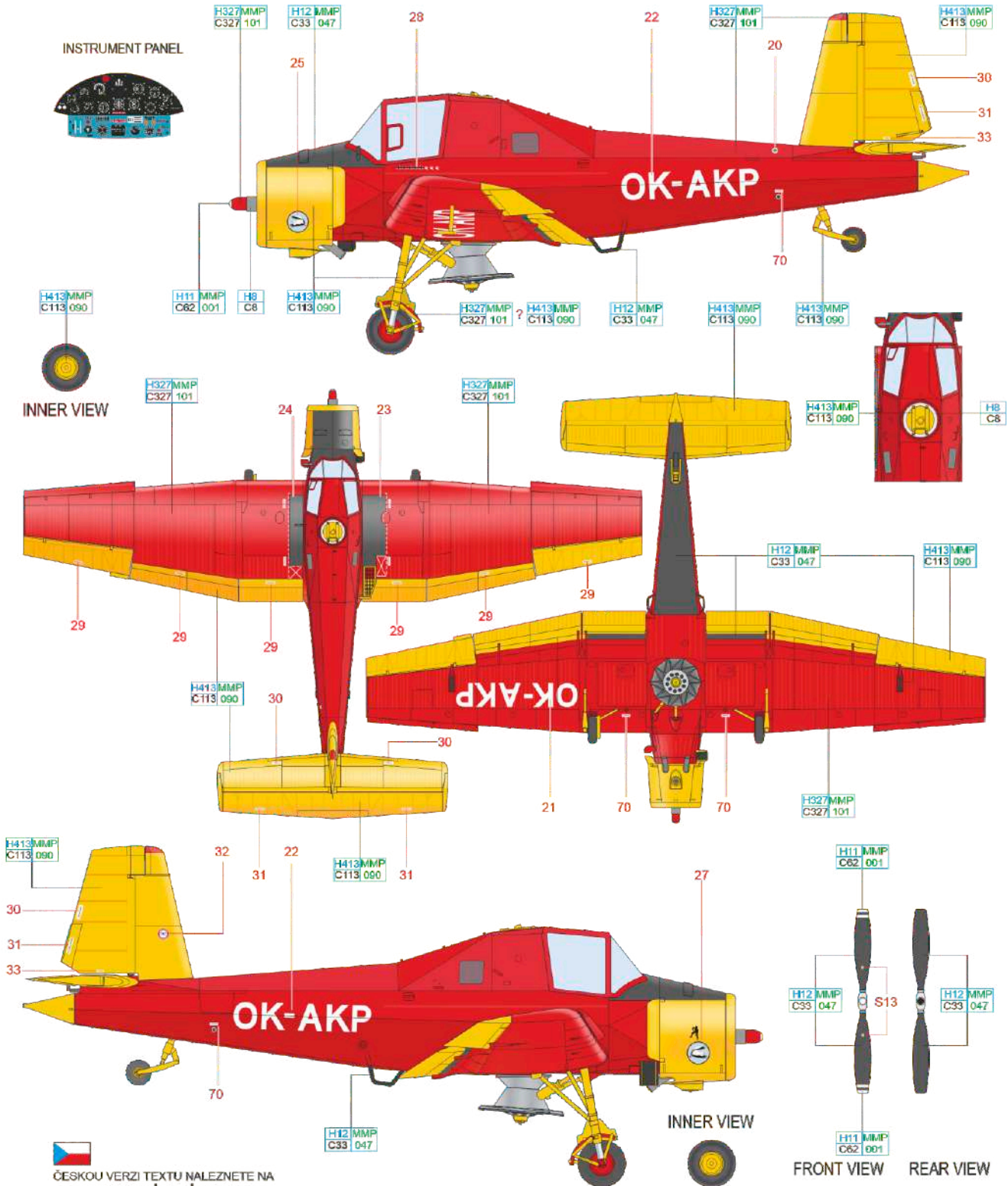

ČESKOU VERZI TEXTU NALEZNETE NA
www.eduard.com
 POD KATALOGOVÝM ČÍSLEM 7456

our special thanks to
Mr. Petr Chmelík
 for his kind cooperation

eduard

B OK-HJH

Z-37A, with the serial number 23-11 was manufactured in 1977, and in May of that year, it was registered to Slov-Air in Prague, where it served with red elements on the wing. The mouth and caterpillar was added in 1990 at the airfield in Rakovnik. Currently, it serves with the company AgroAirVa s.r.o. and is painted overall yellow.

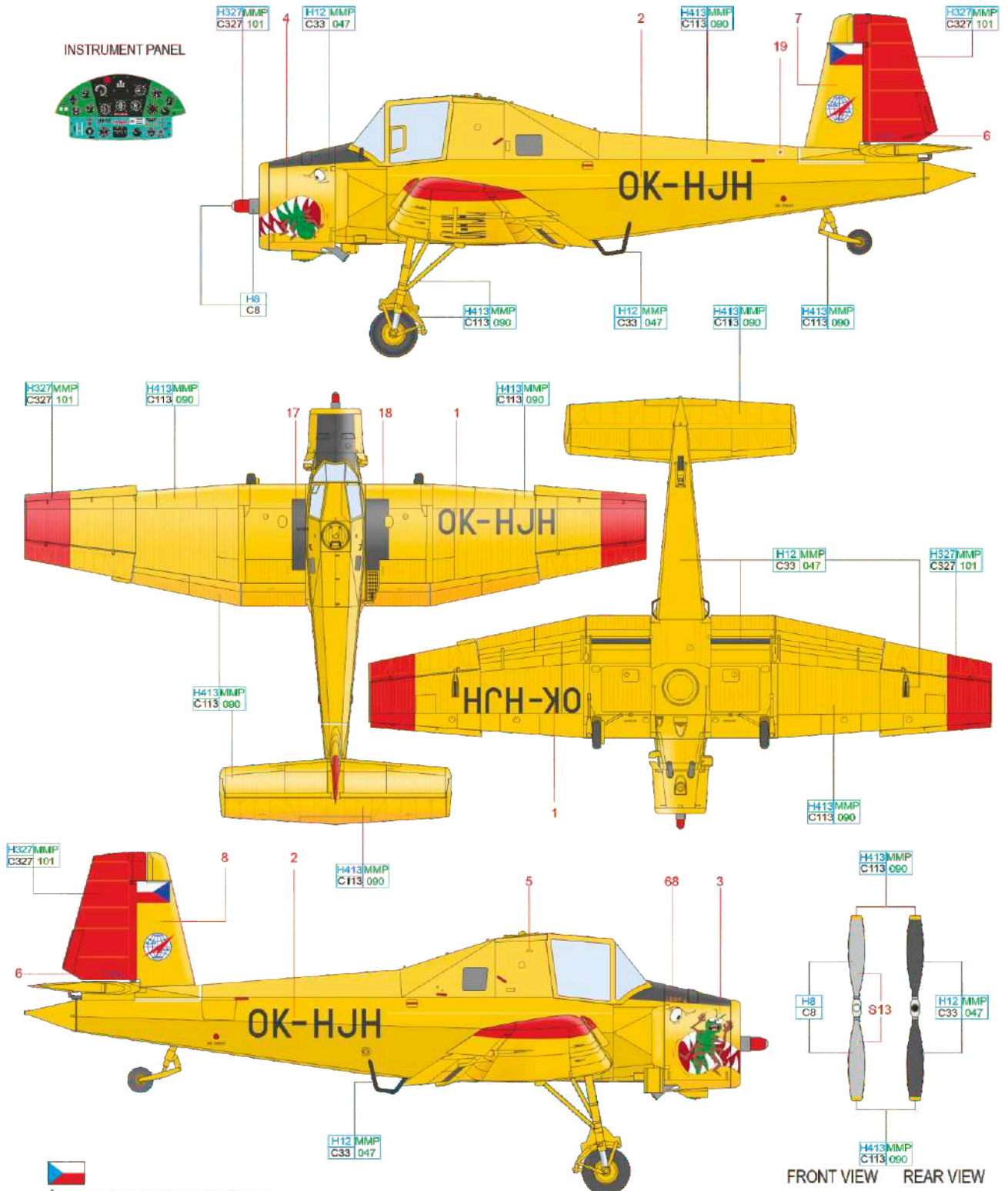

ČESKOU VERZI TEXTU NALEZNETE NA
www.eduard.com
 POD KATALOGOVÝM ČÍSLEM 7456

our special thanks to

Mr. Petr Kolmann

for his kind cooperation

YELLOW H413/MMP C113 090 RED H327/MMP C327 101 BLACK H12/MMP C33 047 SILVER H8 C8

eduard

D RA-1349G

This aircraft was built in 1975 and delivered to East Germany, carrying the registration DDR-SVW. In 1990, it was redesignated as D-SEVW. It found its way to Russia in 2010, with the registration RA-1349G coming in 2015. On September 12th, 2018, fifty-two-year-old Vladimir Zelenov was crop dusting with this aircraft when it crashed near the village of Tagay in the Ulyanovsk region. Unfortunately, the pilot did not survive the crash.

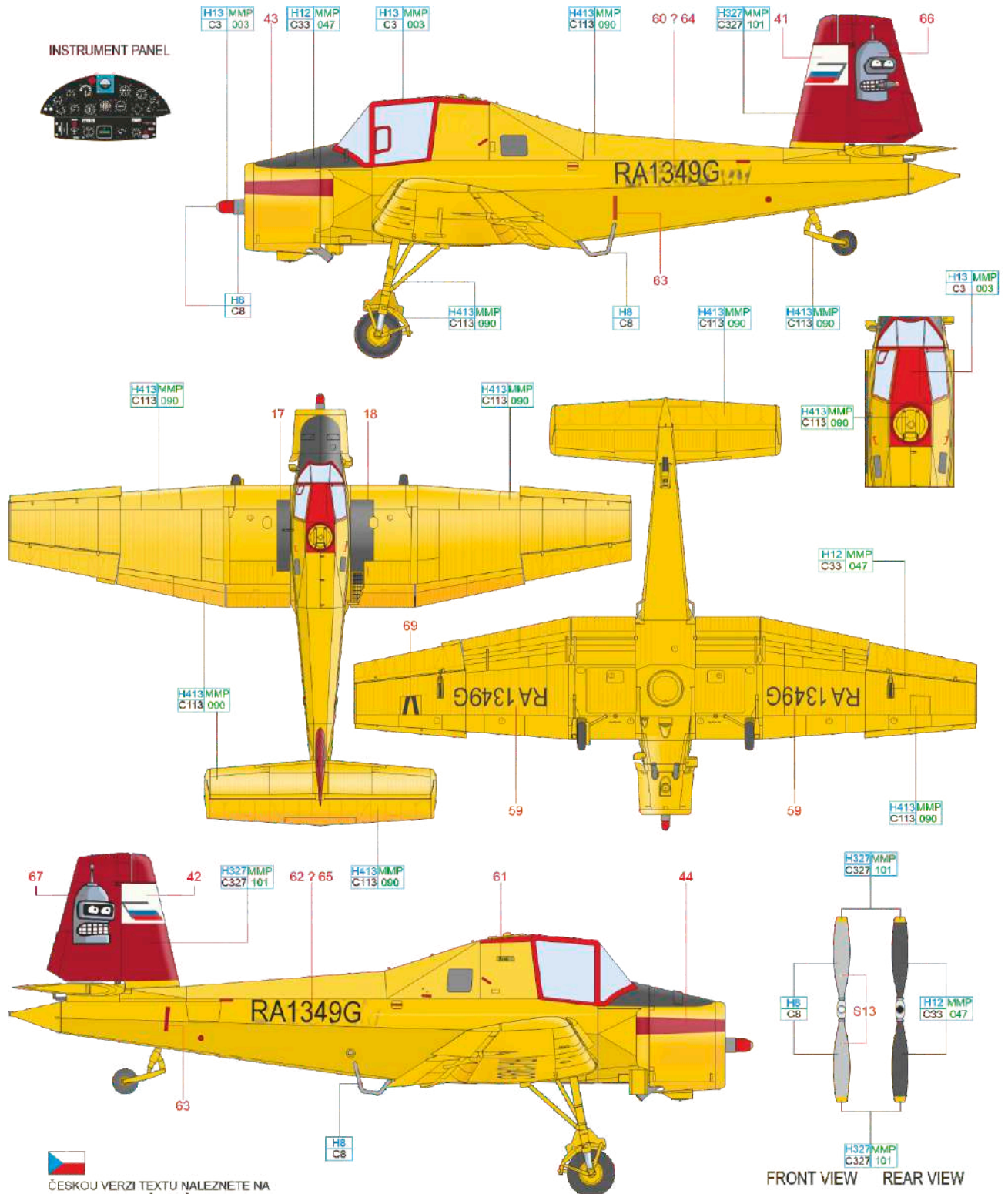

ČESKOU VERZI TEXTU NALEZNETE NA
www.eduard.com
 POD KATALOGOVÝM ČÍSLEM 7456

YELLOW H413 MMP C113 090 RED H13 MMP C3 003 RED H327 MMP C327 101 BLACK H12 MMP C33 047 SILVER H8 C8

our special thanks to
Mr. Jan Kohout
 for his kind cooperation

eduard

