

MiG-21MF Fighter Bomber

eduard

1/72 Scale Plastic Model Kit

WEEKEND
edition



item No. 7458

The MiG-21 was the most-produced supersonic fighter in the world serving with more than fifty Air Forces over four continents.

The MiG-21 was one of a long-list of Mikoyan-Gurevich designs integrated into the armed forces of the Soviet Union, the Warsaw Pact, and allied client states. Its predecessors included such notable types as the MiG-15, MiG-17, and the supersonic MiG-19. The roots of MiG-21 project reach back to the first half of the fifties. In 1954, when the preliminary design study Ye-1 came to its end and was quickly replaced by the reworked Ye-2 prototype. Both had a swept wing. The first MiG design to feature the delta wing was the Ye-4 prototype, which took to the air for the first time on June 16, 1955. It was also demonstrated a year later at the Moscow airfield Tushino.

The new aircraft with the MiG-21 designation was the first successful Soviet design integrating fighter and interceptor characteristics. It was also quite light Mach 2 aircraft, although the long-lasting development was adding weight gradually. The design featured sleek fuselage with the front air intake and shock cone. This feature later limited future development due to the very small space available for the radar.

Cold War warrior

The first of the new line to enter production was the MiG-21F, which together with the MiG-21P and MiG-21F-13 represented the first generation of this line. These versions were in production through the end of the fifties and the beginning of the sixties. Subsequent versions included the PF, FL, PFM and R with production of these peaking at the end of the sixties. The third generation started production in 1968 and included the most advanced versions of MiG-21 like the M, SM, MF, SMT or bis among others. Simultaneously, two-seat training versions were also produced designated MiG-21U, UM and US.

Production of the MiG-21 ended in 1985. The new aircraft came off Soviet production lines in Moscow, Gorky and Tbilisi, the MiG-21F-13 was also built under license in Czechoslovakia and the MiG-21FL, M and bis in India by Hindustan Aeronautics Ltd. The Soviet Union produced 10,645 examples of all versions, 194 were built in Czechoslovakia and 657 in India. That counts 11,496 aircraft produced.

Over the course of the Cold War, the opponents of the MiG-21 included the likes of the Northrop F-5 Freedom Fighter or the Dassault Mirage III. NATO assigned it the reporting name "Fishbed", while the Soviet pilots called it "Balalaika" due to the shape resemblance with the Russian musical instrument.

Aces from Asia, Middle East or Africa

Outside of the Soviet Union, the type flew with a long list of nations on four continents (Europe, Asia, Africa, and South America)

and participated in many conflicts and wars. The most remarkable combat use includes the Vietnam war, the Indo-Pakistan wars, the Cuban participation in Angola and in the Arab world's attempts to eliminate Israel. It is no wonder there were many pilots achieving ace status flying one or more variants of MiG-21. Thanks to the high volume of use and intensive combat actions, the Vietnamese pilots are topping the list of aces of MiG-21. The top of the ladder is occupied by Nguyen Van Coc with nine kills with three eight-victory aces following: Mai Van Cuong, Nguyen Hong Nhi and Pham Thanh Ngan. Of the other nations the Syrian pilots Bassam Hamshun and Majid Zugbi both achieved seven kills flying MiG-21MF, while Adeb AL-Jarf had the same score with MiG-21FL and Egyptian pilots Ali Vajai, Sami Marei and Sami Marei scored five times.

In the interceptor role the MiG-21 served with the Soviet Union and other nations of the Warsaw Pact into the eighties when it began to be replaced by the MiG-23 in seventies and MiG-29 Fulcrum in eighties.

This kit: MiG-21MF

This plastic model kit represents the MiG-21MF, an export version of the MiG-21SM where the "M" signifies "modernizovaniy" (modernized) and the "F" "forsirovanniy" (with afterburner). The MiG-21MF lacked some of the "sensitive" avionics equipment of the SM version. On the other hand, it also sported some improvements to its export predecessor, the MiG-21M, in several aspects. It was powered by more powerful Tumansky R-13-300 engine with afterburner and carried the Safir-21/RP-22 radar instead of less effective RP-21MA of MiG-21M. The MiG-21MF type was identified as Izdelye (series) 96F in factory documentation.

The production started in the Moscow factory No. 30, with first batch of 96 production aircraft in 1969 (it is believed these were shipped to Egypt). Starting from 1974 the production was shifted to the No. 21 factory in Gorkhyi, where 231 aircraft were built before the production shifted to the MiG-21bis version in 1976.

Although the MiG-21MF was export version, several aircraft saw service with 234. GvIAP (Guard Fighter Regiment) of VVS (Voenno-Vozdushnie Sily - Air Force) located at the Kubinka air base. The reason was quite simple - the unit was tasked with flight demonstrations for foreigner customers and also with the official parade and display flights.

The armament consisted of the GS-23-2L 23mm cannon with 200 rounds. The underwing pylons could carry a combination of FAB bombs up to 500 kg caliber, UB-16-57 rocket pods, R-3S, Ch-66 or S-24 missiles, and R-60 air-to-air missile, including the R-60M. NATO assigned the MiG-21MF codename "Fishbed J".



Carefully read instruction sheet before assembling. When you use glue or paint, do not use near open flame and use in well ventilated room. Keep out of reach of small children. Children must not be allowed to suck any part, or pull vinyl bag over the head.



Před započatím stavby si pečlivě prostudujte stavební návod. Při používání barev a lepidel pracujte v dobře větrané místnosti. Lepidla ani barvy nepoužívejte v blízkosti otevřeného ohně. Model není určen malým dětem, mohlo by dojít k požití drobných dílů.

INSTRUCTION SIGNS * INSTR. SYMBOLS * INSTRUKTION SINNBILDEN * SYMBOLES * 記号の説明



OPTIONAL
VOLBA



BEND
OHNOU



SAND
BROUST



OPEN HOLE
VYVRTAT OTVOR



SYMETRICAL ASSEMBLY
SYMETRICKÁ MONTÁŽ



REMOVE
ODRÍZNOUT



REVERSE SIDE
OTOČIT



APPLY EDUARD MASK
AND PAINT
POUŽÍT EDUARD MASK
NABARVIT

PARTS



DÍLY



TEILE



PIÈCES



部品

PLASTIC PARTS

B>

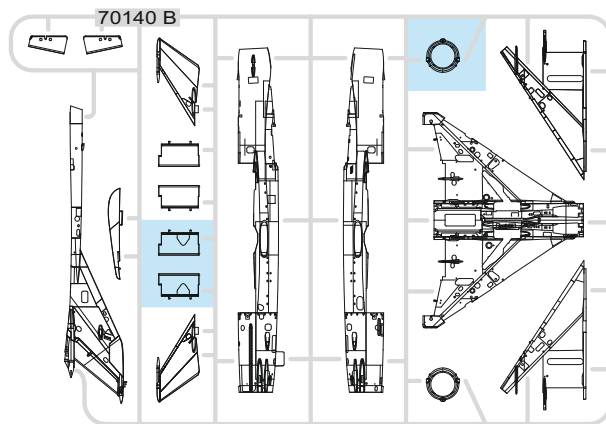

C>

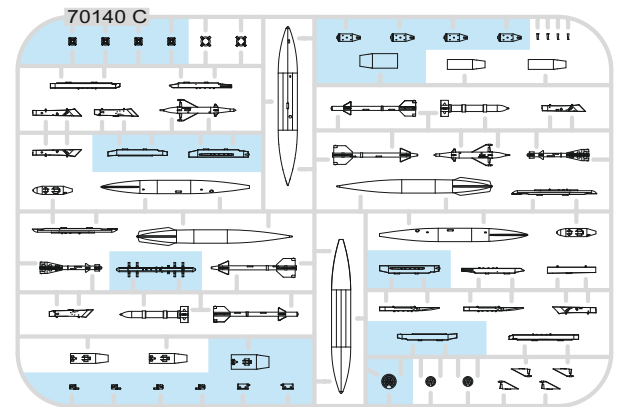

D>

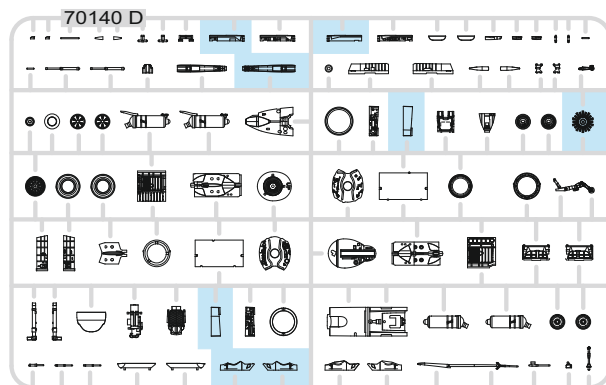

E>

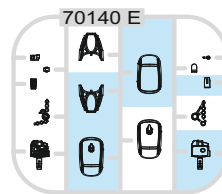

-Parts not for use. -Teile werden nicht verwendet. -Pièces à ne pas utiliser. -Tyto díly nepoužívejte při stavbě. - 使用しない部品

COLOURS



BARVY



FARBEN



PEINTURE



色

GSI Creos (GUNZE)		MISSION MODELS	
AQUEOUS	Mr.COLOR	PAINTS	
H1	C1	MMP-001	WHITE
H3	C3	MMP-003	RED
H4	C4	MMP-007	YELLOW
H5	C5	MMP-048	BLUE
H7	C7	MMP-002	BROWN
H11	C62	MMP-001	FLAT WHITE
H12	C33	MMP-047	FLAT BLACK
H14	C59	MMP-005	ORANGE
H15	C65		BRIGHT BLUE
H23	C79		SHINE RED
H26	C66		BRIGHT GREEN
H27	C44		TAN
H47	C41	MMP-012	RED BROWN
H51	C11	MMP-063	LIGHT GULL GRAY
H53	C13		NEUTRAL GRAY
H60	C16		GREEN
H70	C60	MMP-056	GRAY
H77	C137	MMP-040	TIRE BLACK
H78	C38		OLIVE GREEN
H81	C55	MMP-023	KHAKI

GSI Creos (GUNZE)		MISSION MODELS	
AQUEOUS	Mr.COLOR	PAINTS	
H82	C31		DARK GRAY (1)
H84	C42		MAHOGANY
H90	C47		CLEAR RED
H94	C138		CLEAR GREEN
H303	C303	MMP-066	GREEN
H305	C305	MMP-084	GRAY
H332	C332		LIGHT AIRCRAFT GRAY
H334	C334	MMP-102	BARLEY GRAY
H338	C338	MMP-116	LIGHT GRAY
H417	C117	MMP-051	LIGHT BLUE
	C199		SANDY BROWN
	C391		INTERIOR GREEN
Mr.METAL COLOR		METALLICS	
MC213		MMM-006	STEEL
MC214		MMM-001	DARK IRON
MC218		MMM-003	ALUMINIUM
Mr.COLOR SUPER METALLIC		METALLICS	
SM201		MMC-001	SUPER FINE SILVER 2
SM206		MMC-001	SUPER CHROME SILVER 2

1 =

H70 MMP	C60 056	- MARKINGS A, B, C
GRAY		
MC218	MMM1	- MARKING D
003		

ALUMINIUM

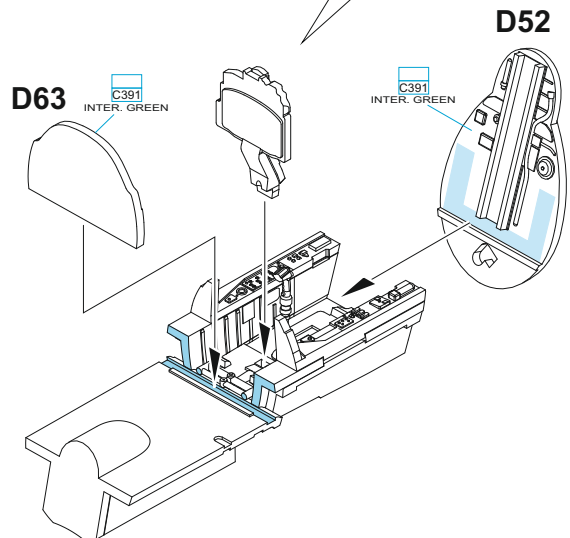
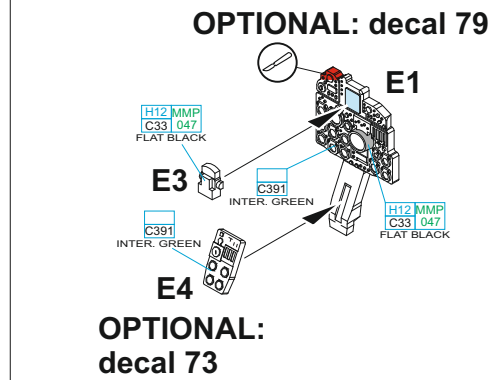
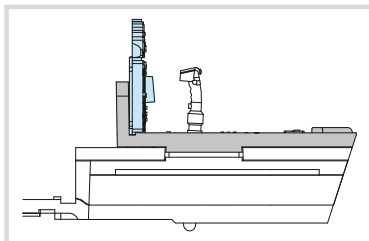
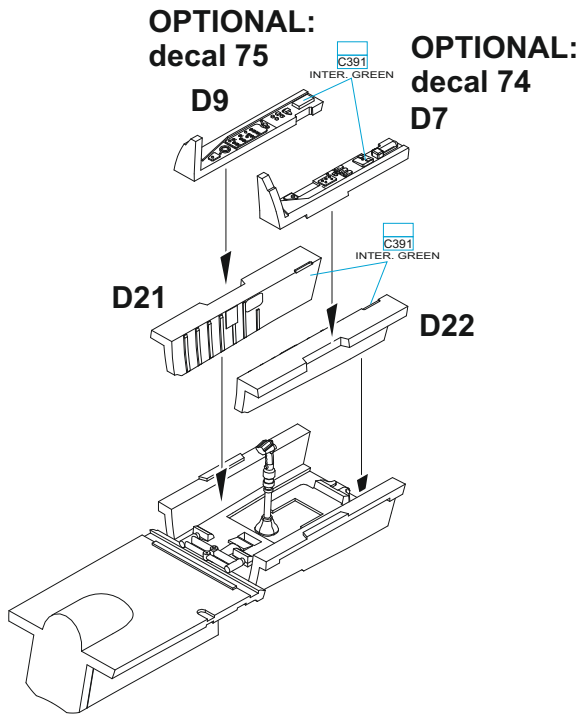
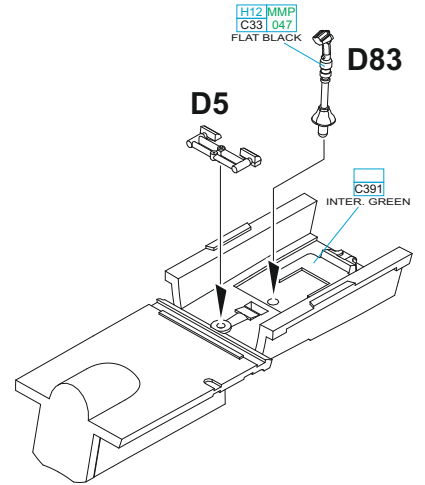
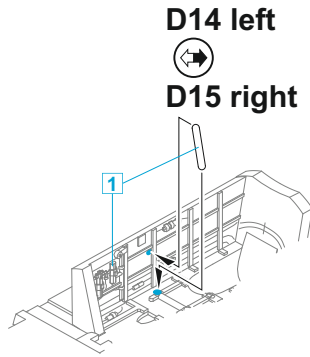
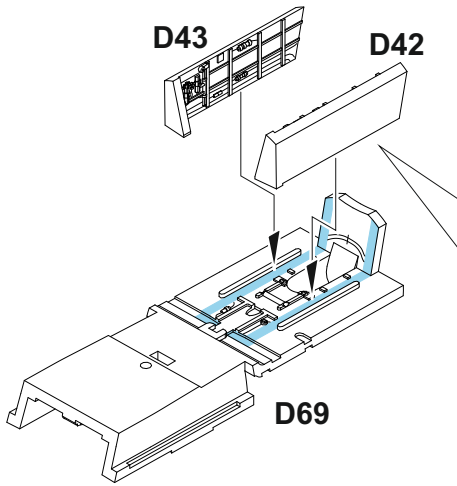

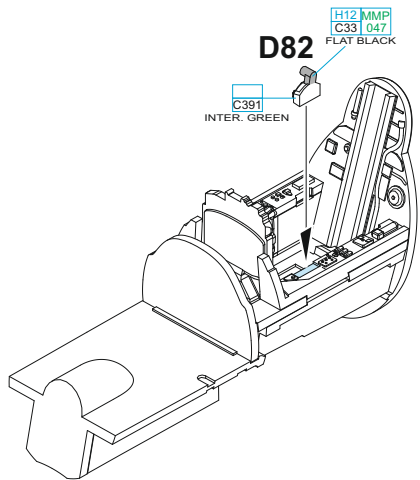
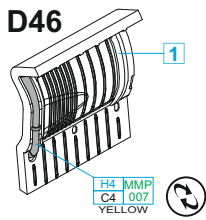
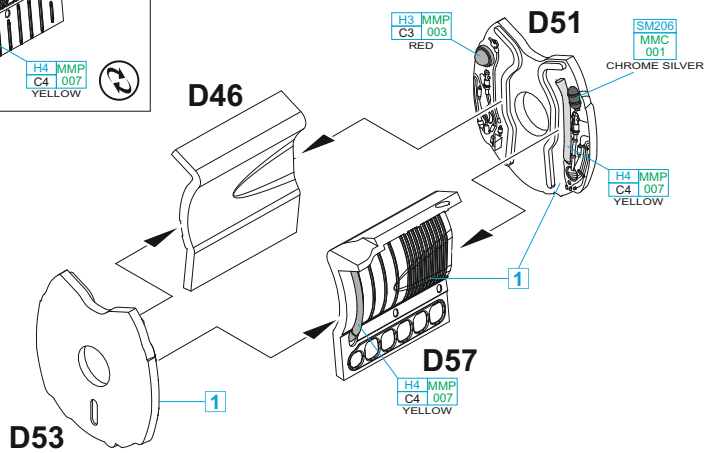
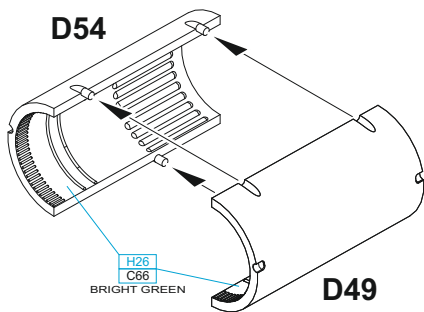
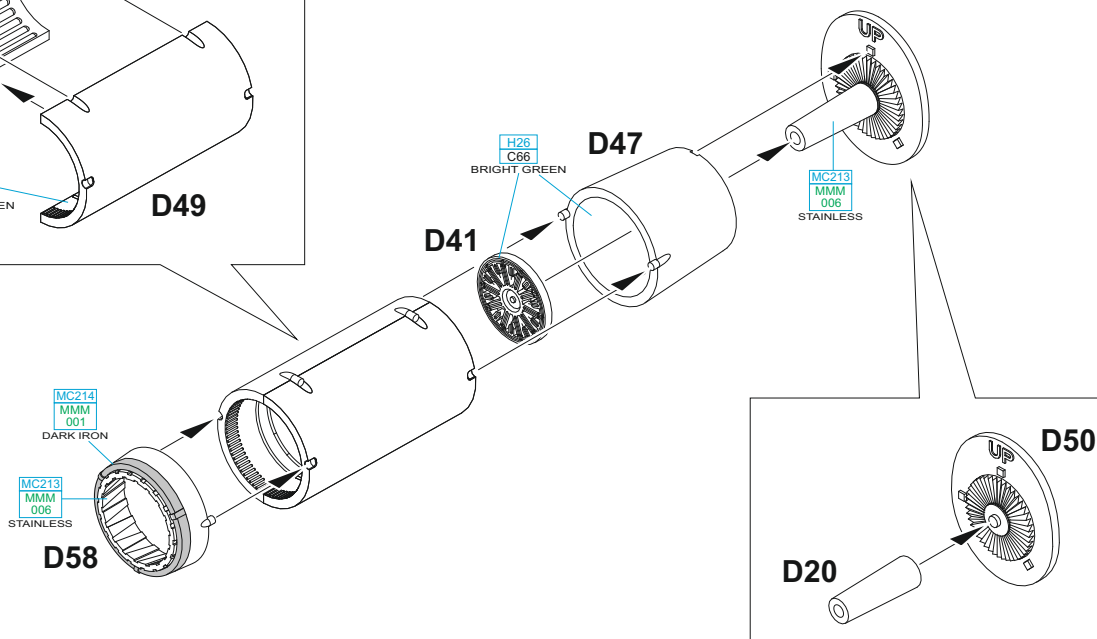
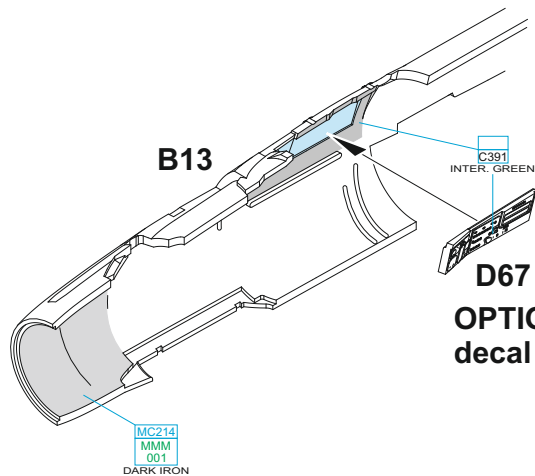
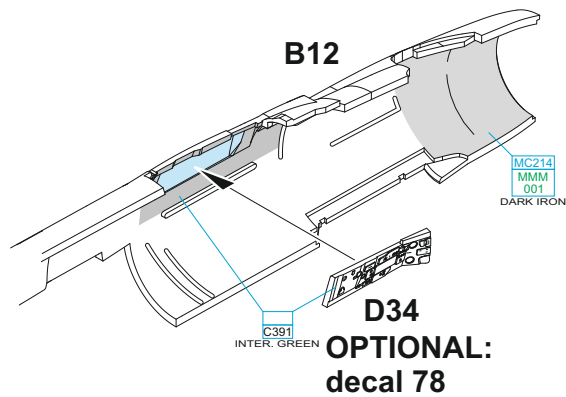
A**D46****B****D54****C****B13****B12**

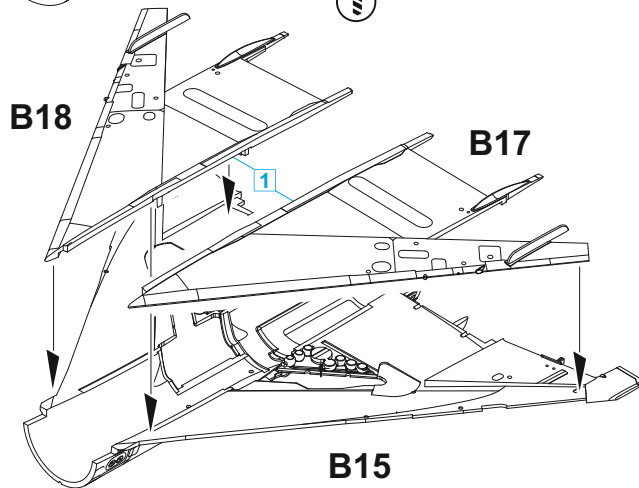
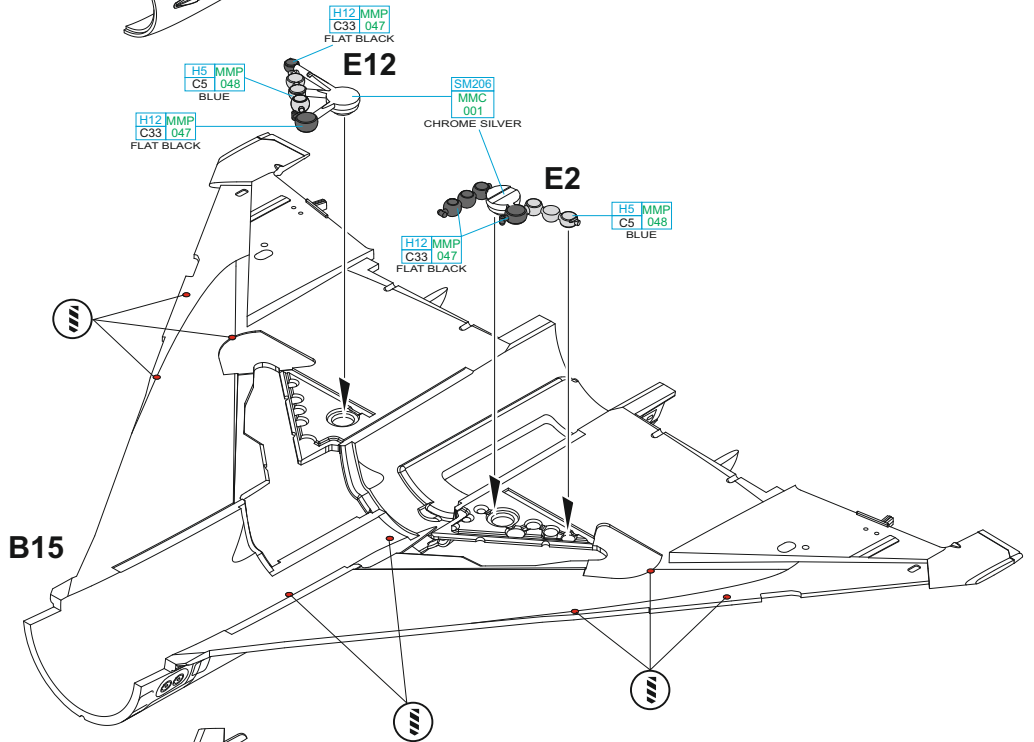
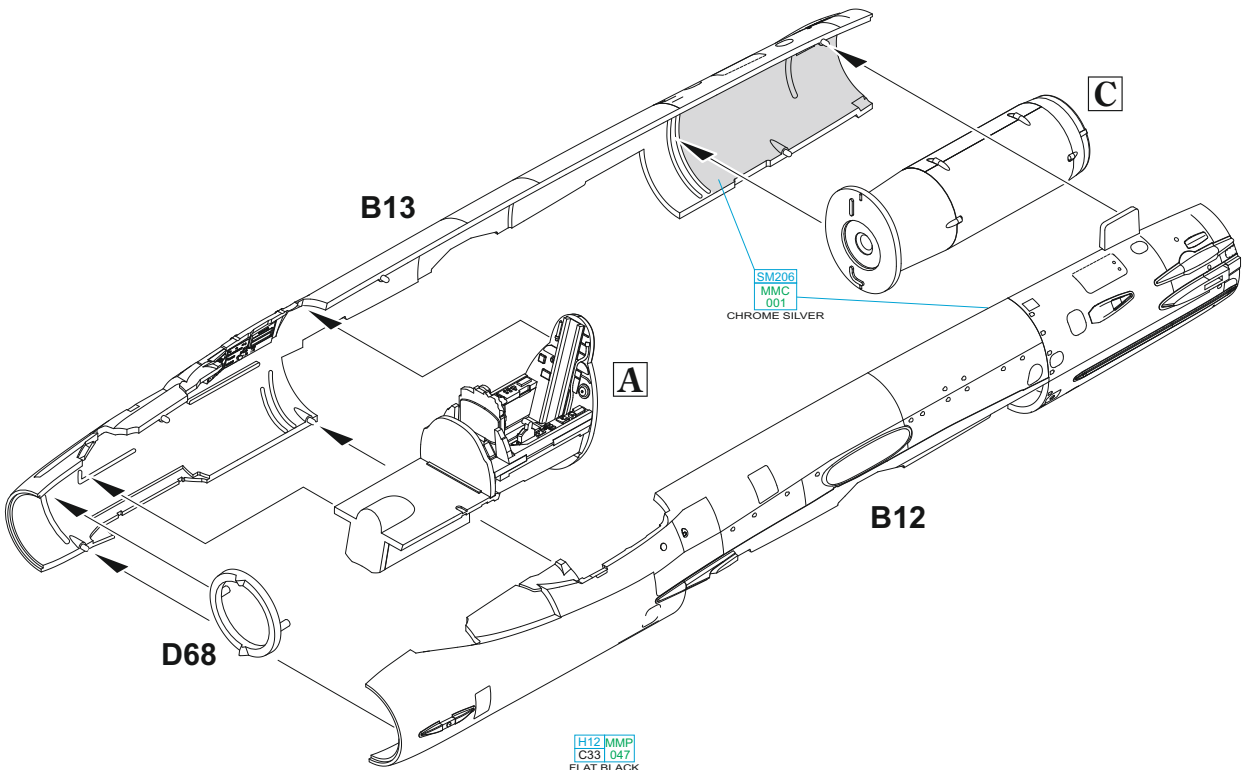

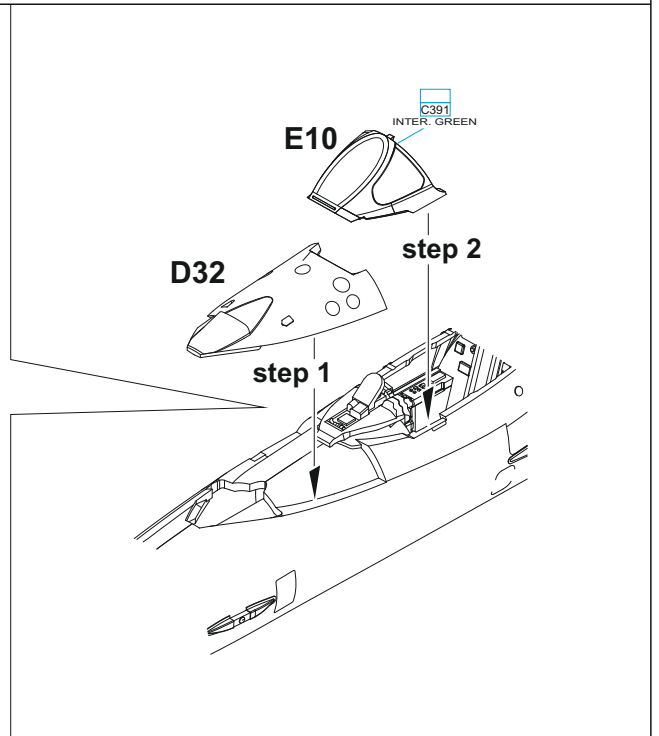
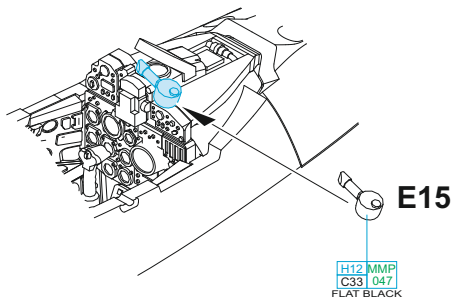
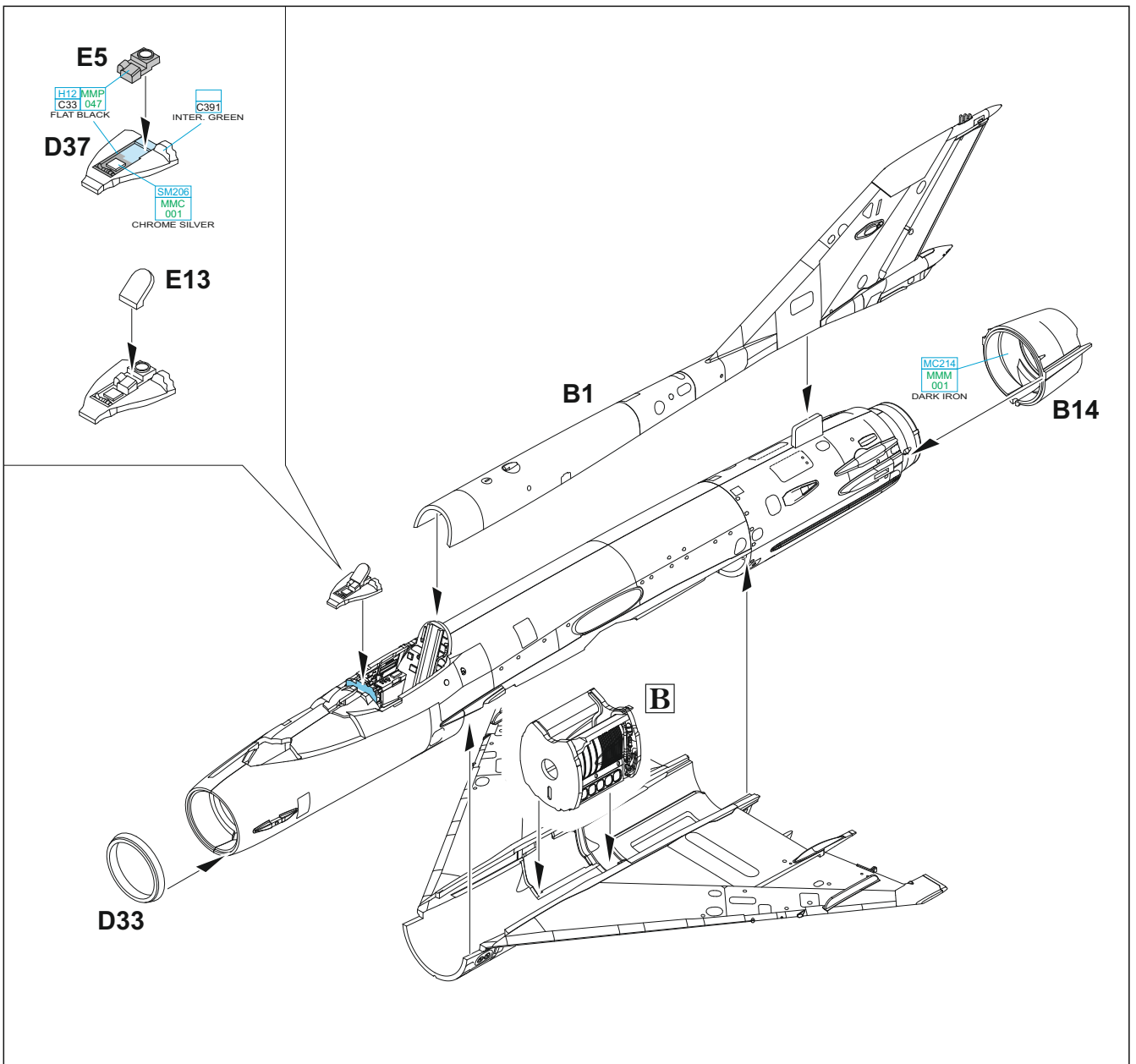

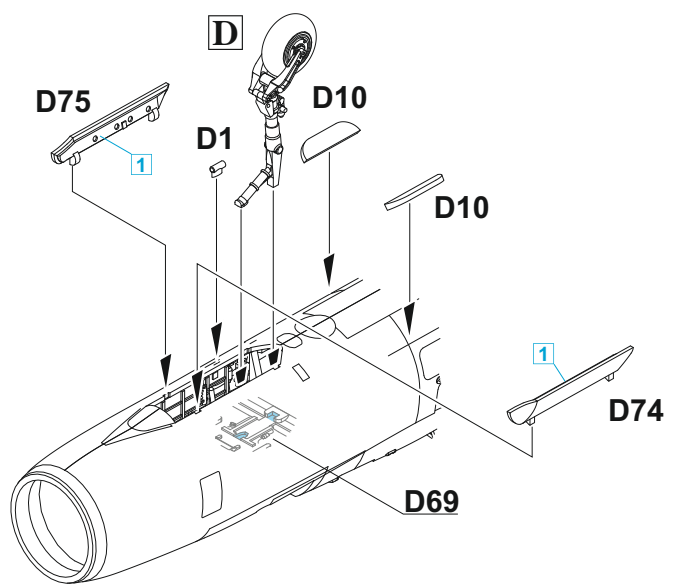
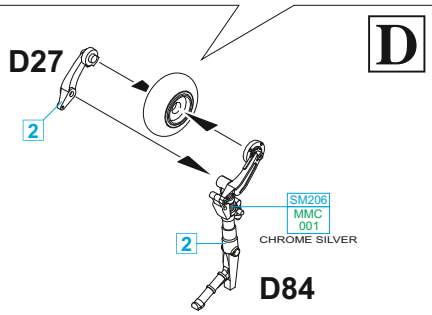
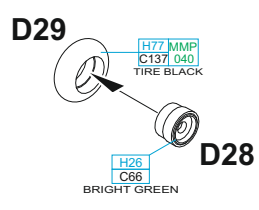
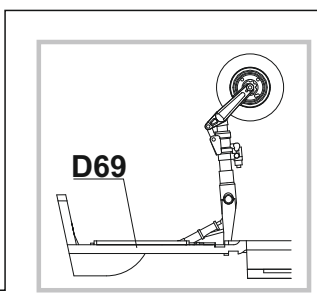
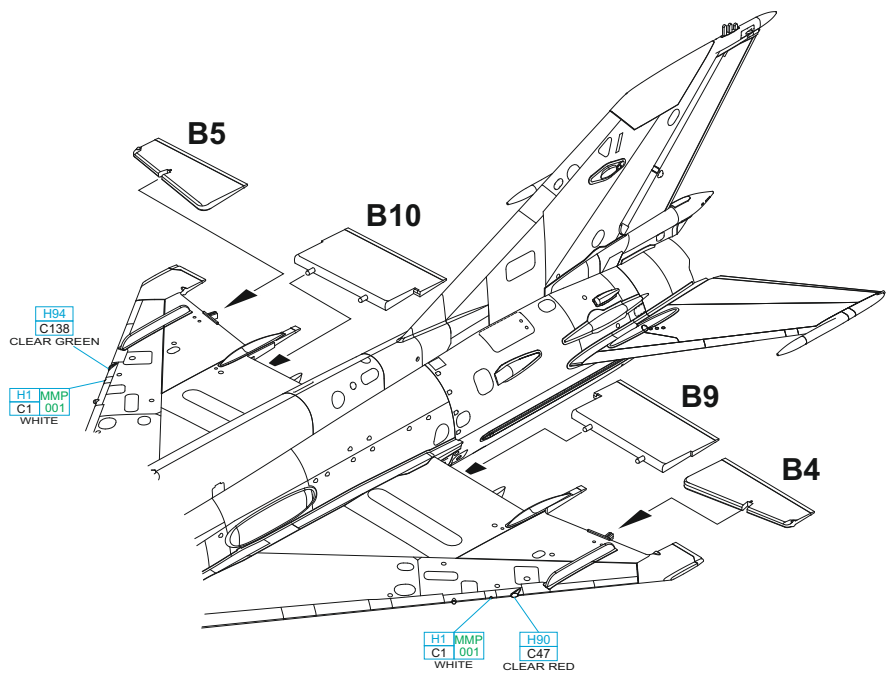
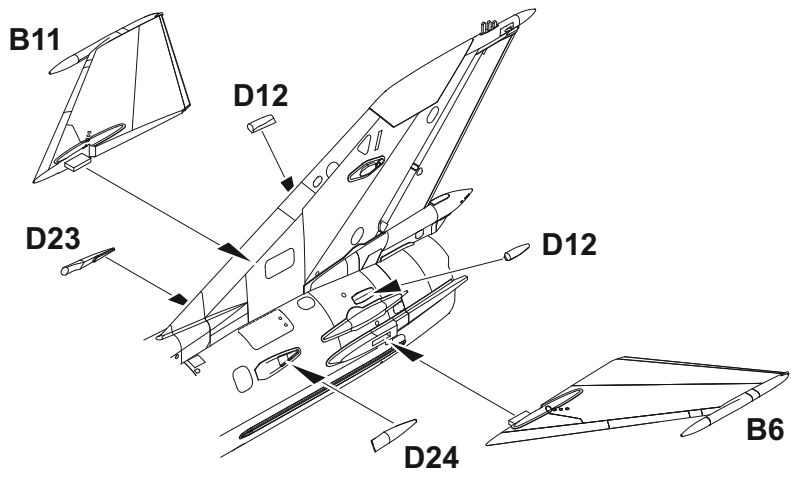

2 = **H151 MMP C111 063** - MARKINGS **B, C, D**
LIGHT GULL GRAY

H338 MMP C338 116 - MARKING **A**
LIGHT GRAY

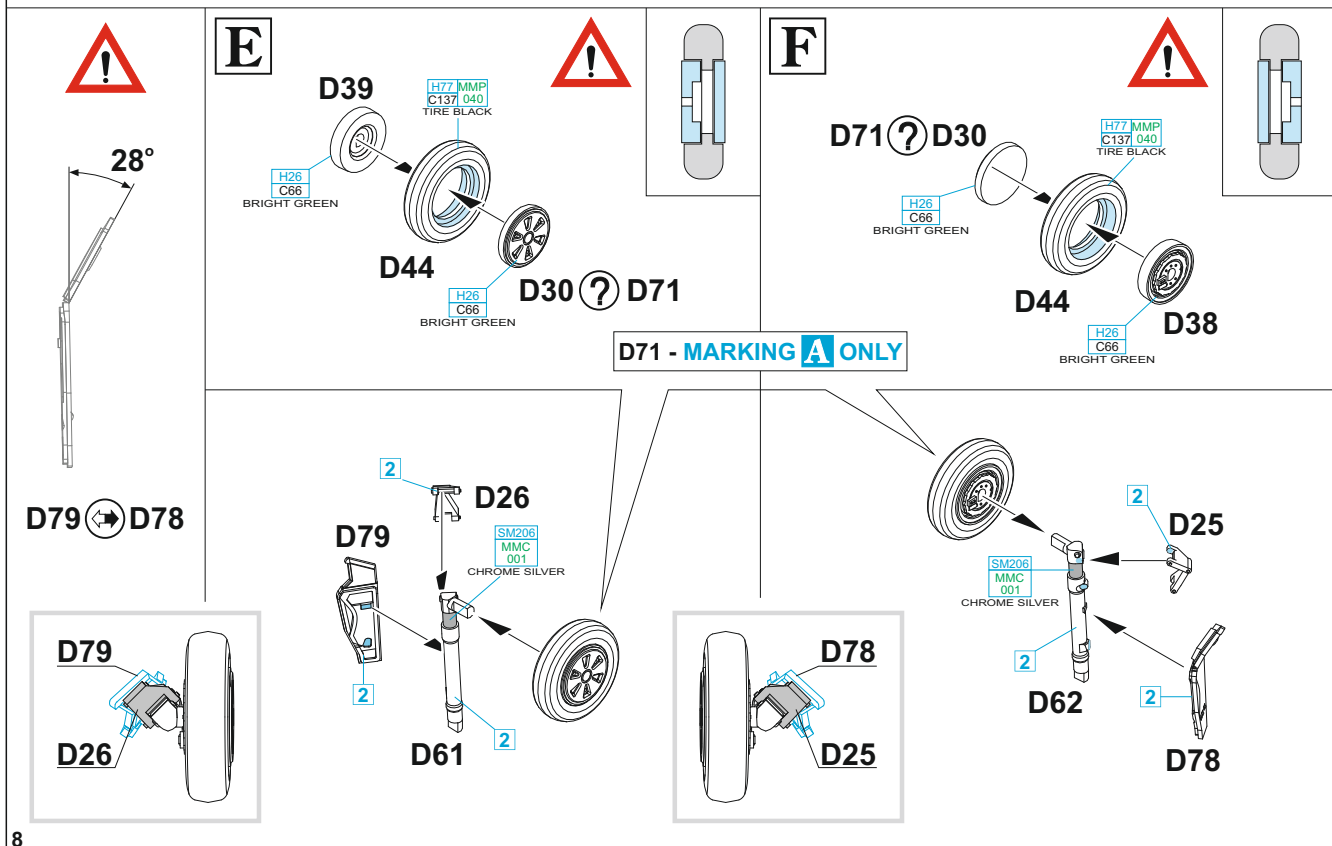
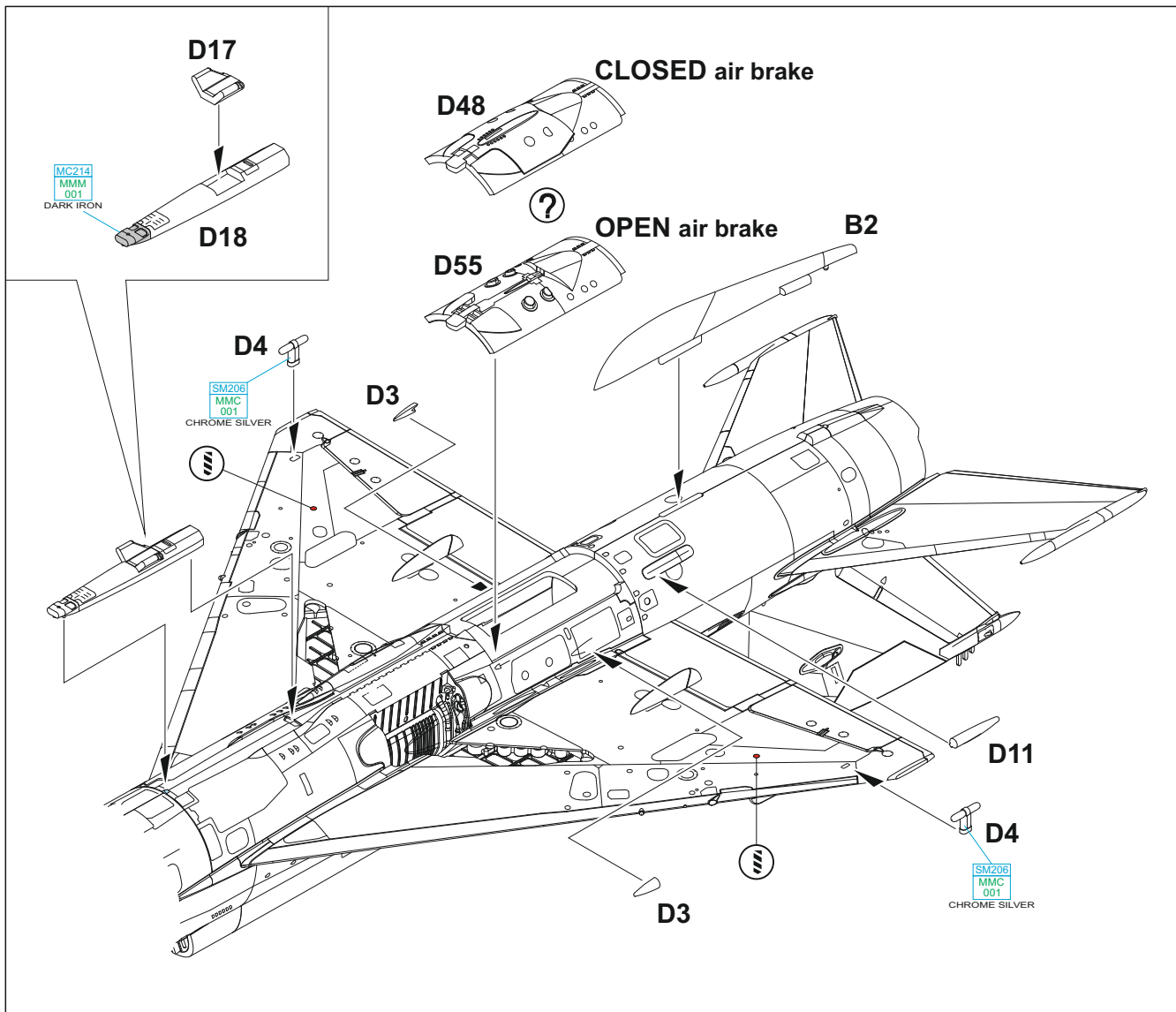

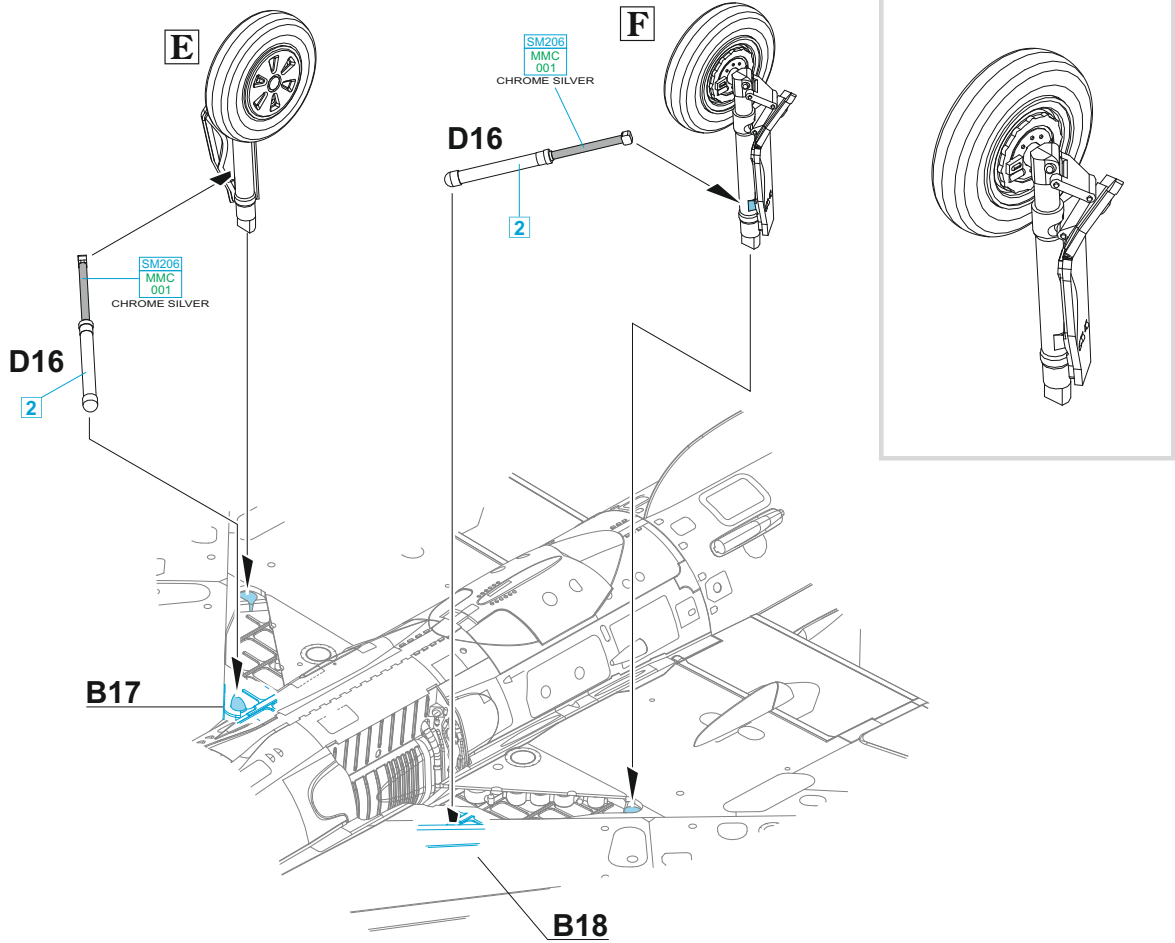

- H26 C66 - MARKING **A**
BRIGHT GREEN
- 3** = H51 MMP C11 063 - MARKINGS **B, C**
LIGHT GULL GRAY
- MC218 MMM 003 - MARKING **D**
ALUMINIUM

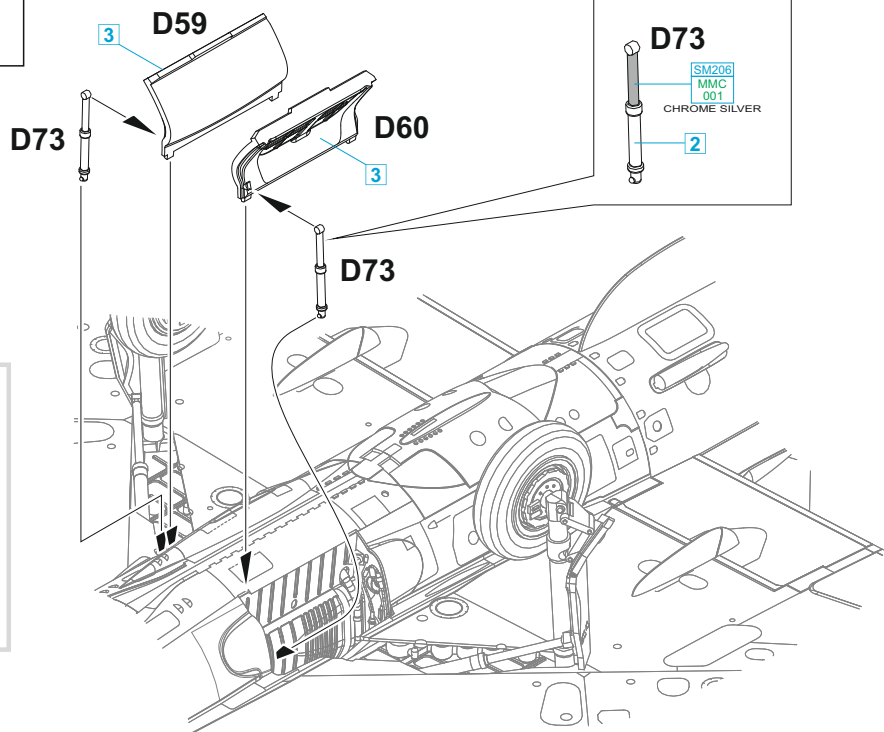

G 2 pcs.

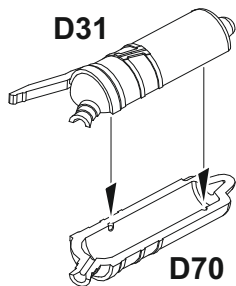

H1 MMP C1 001 WHITE ?
 H51 MMP C11 063 GRAY ?
 SM206 MMC 001 CHROME SILVER

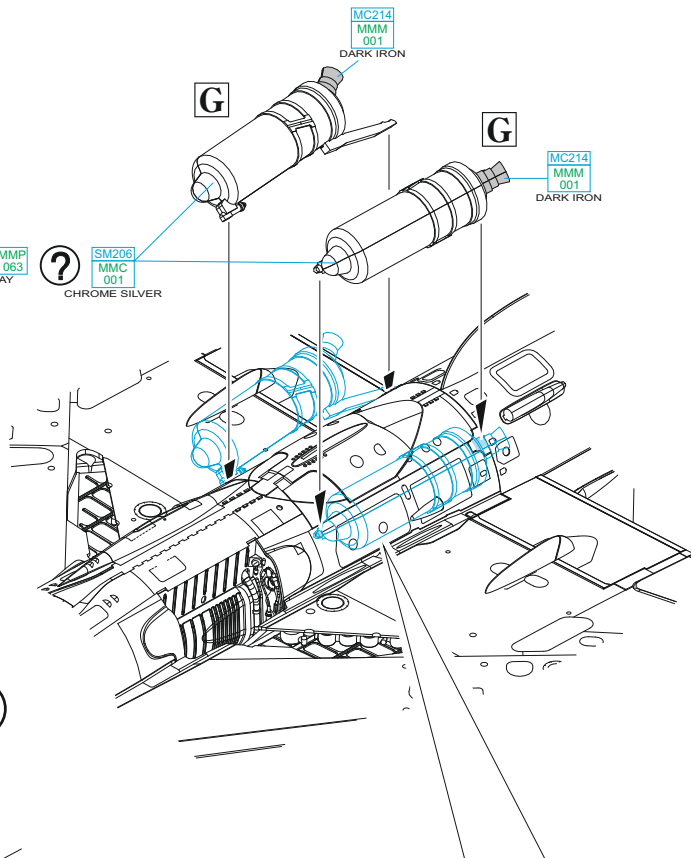

?

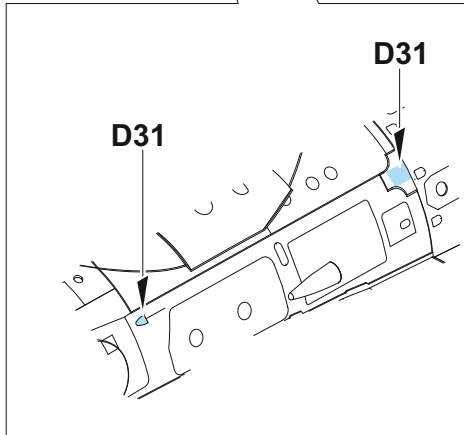
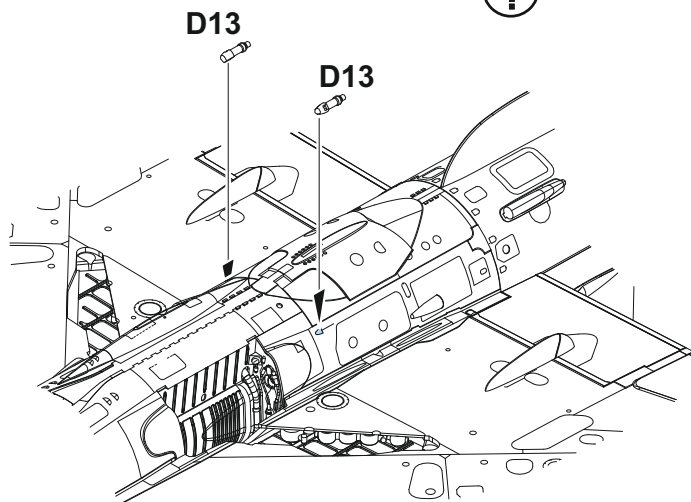

4 =

- H4 MMP C4 007 YELLOW - MARKING **B**
- H26 C66 BRIGHT GREEN - MARKING **A**
- H334 MMP C334 102 BARLEY GRAY - MARKING **D**
- H417 MMP C117 051 LIGHT BLUE - MARKING **C**

?

OPEN air brake
 D45

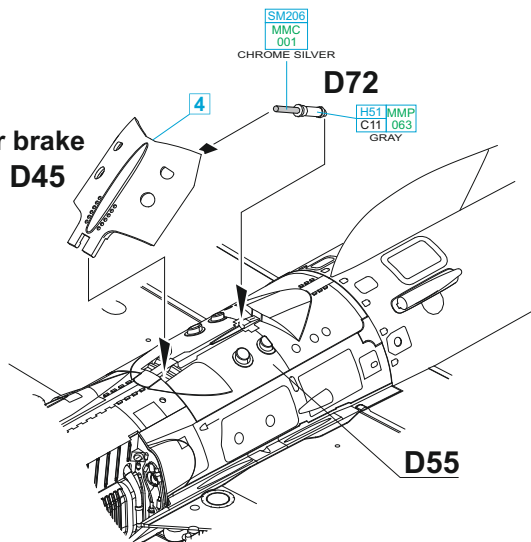
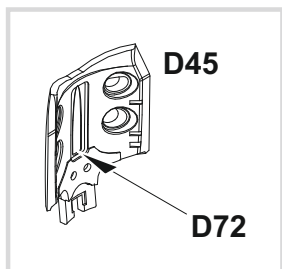

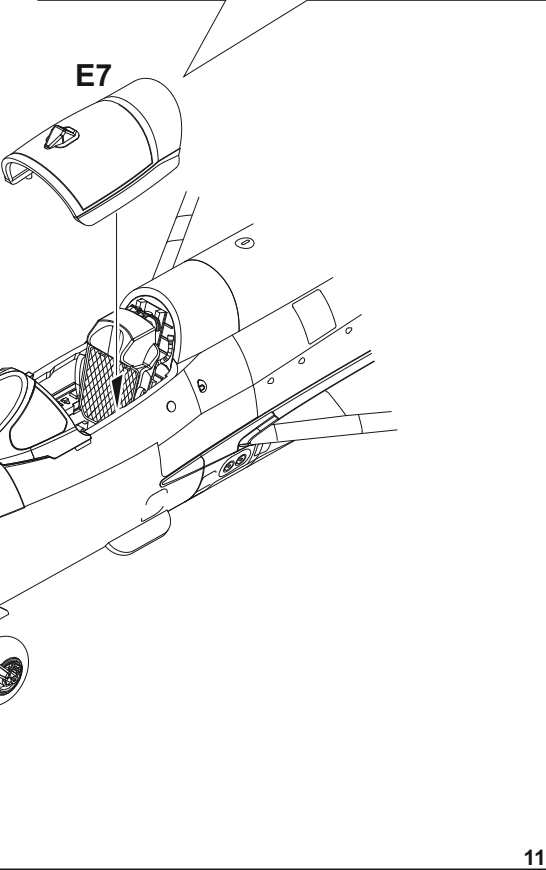
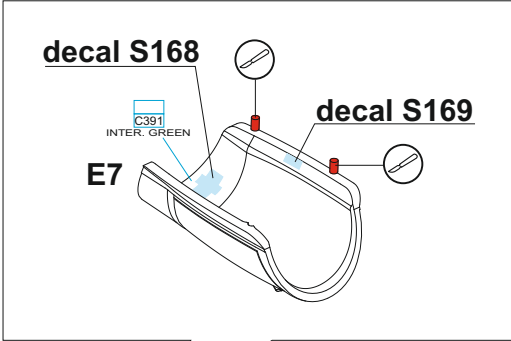
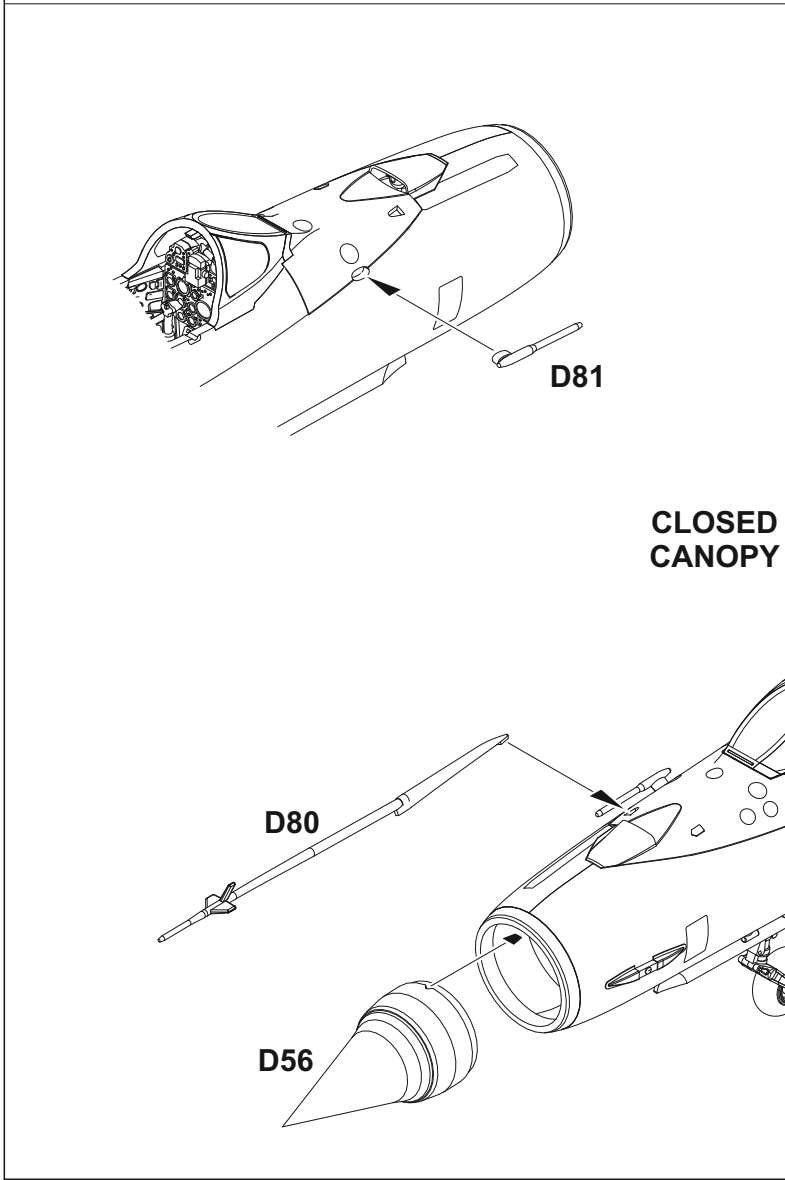
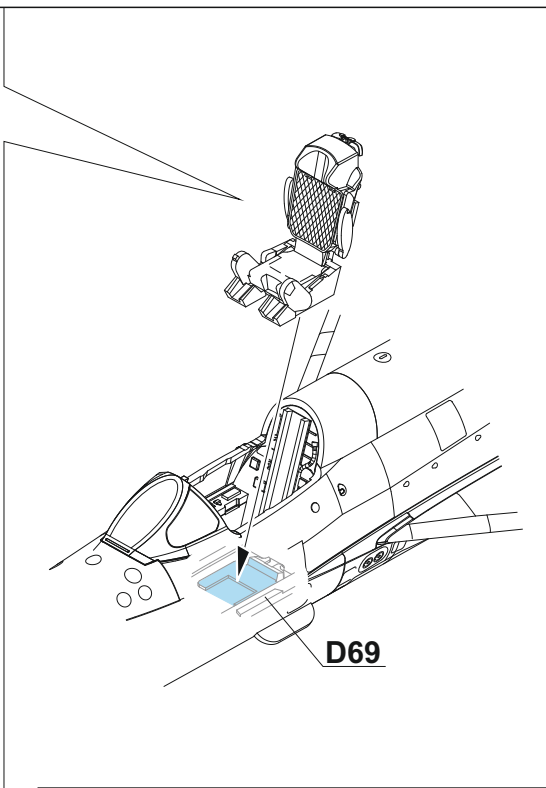
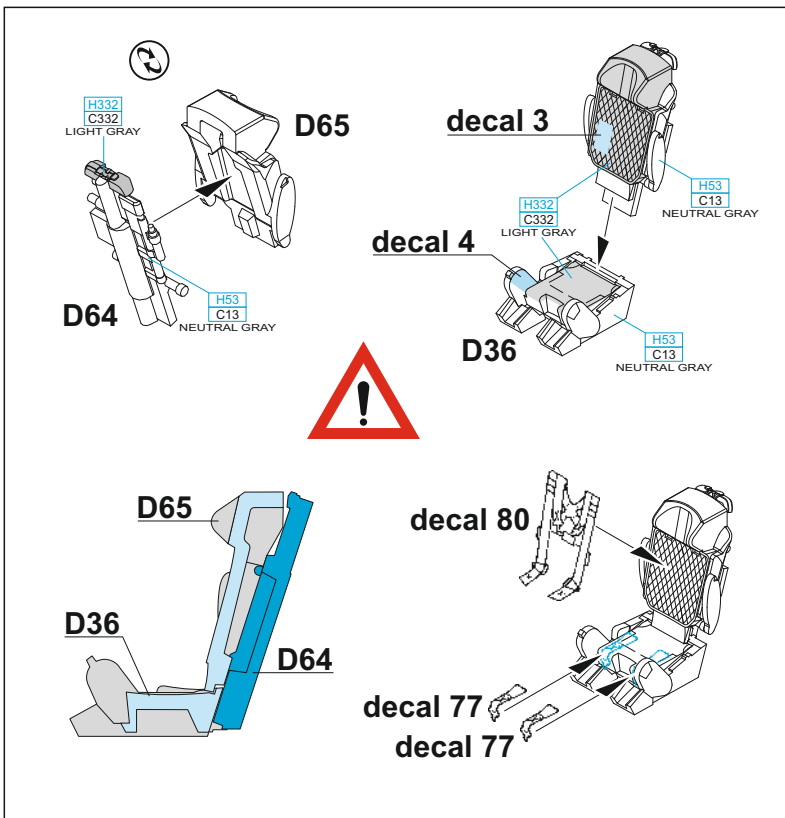

decal S168

C391
INTER. GREEN

decal S169

E7

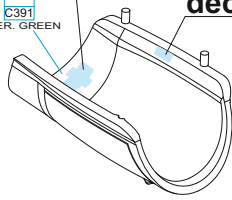

E7

**OPEN
CANOPY**

D2

C391
INTER. GREEN

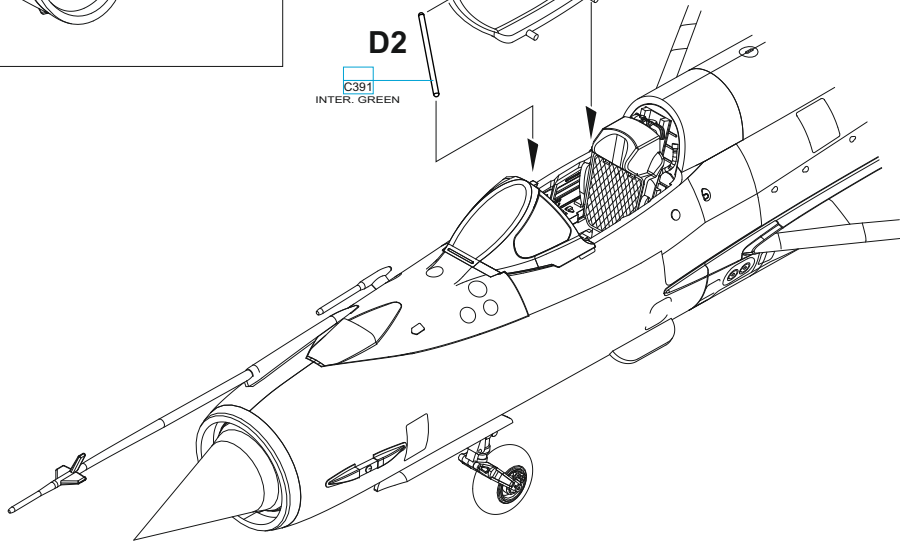

**EXTERNAL
FUEL TANK PYLONS**

C30

UNDERSURFACE
COLOR

C21

UNDERSURFACE
COLOR

**EXTERNAL
FUEL TANK PYLONS**

C40

C10

UNDERSURFACE
COLOR

C41

WEAPON PYLONS

**EXTERNAL
FUEL TANK PYLONS**

C11

UNDERSURFACE
COLOR

WEAPON PYLONS

C9

UNDERSURFACE
COLOR

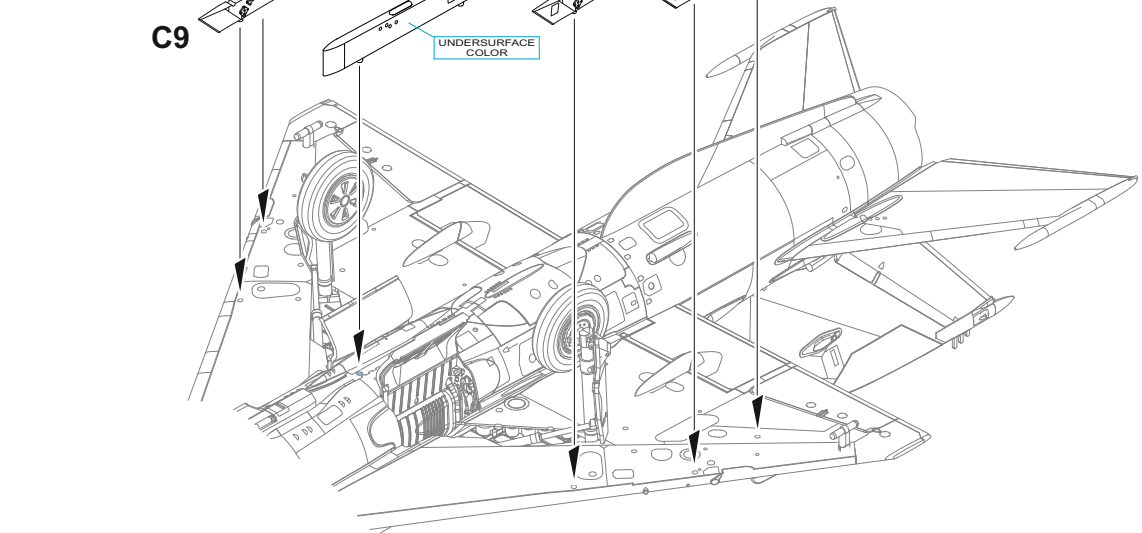

EXTERNAL FUEL TANK 800 I

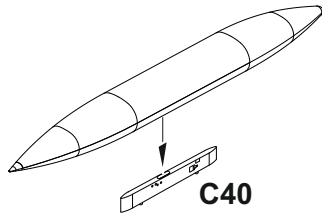
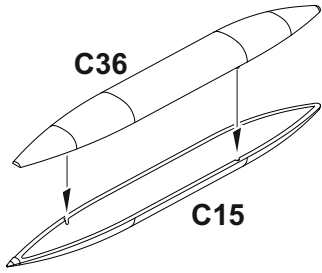

EXTERNAL FUEL TANK 490 I
2 pcs.

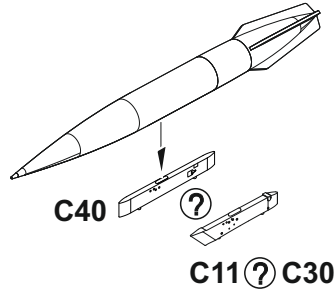
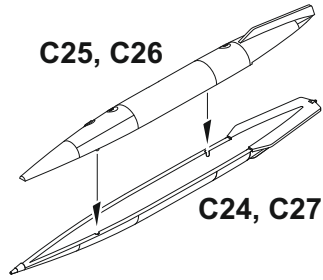

UB-16
2 pcs.

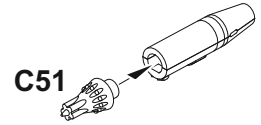
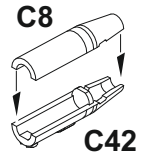

R-13
2 pcs.

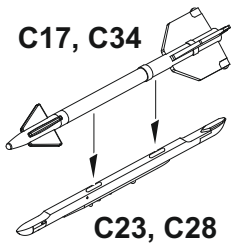

R-3S
2 pcs.

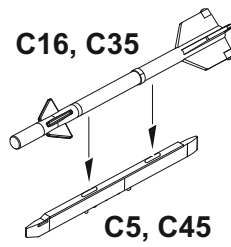

FAB 250
2 pcs.

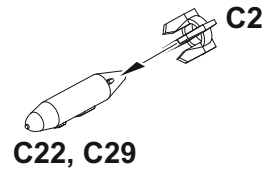

R-60
2 pcs.

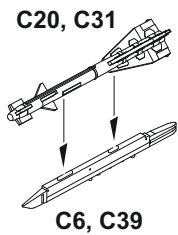

S24
2 pcs.

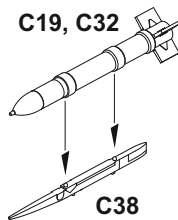

RS-2US
2 pcs.

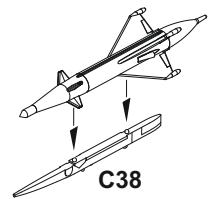
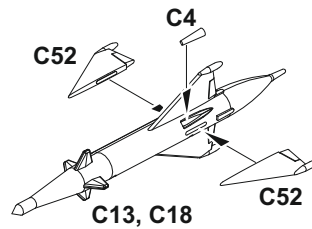

TO CHOOSE WEAPON AND EXTERNAL FUEL TANK OPTION PLEASE FOLLOW YOUR REFERENCE.

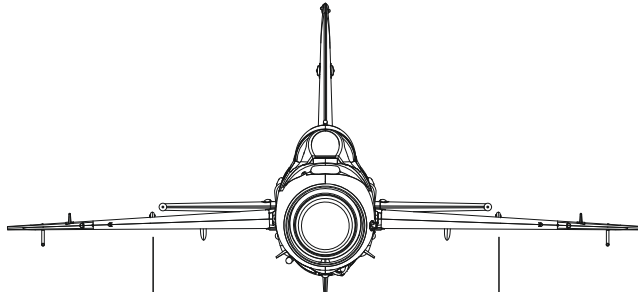

**EXTERNAL
FUEL
TANK 800I**

|| C40



**EXTERNAL
FUEL
TANK 490I**

|| C40



**EXTERNAL
FUEL
TANK 490I**

|| C11



|| C30

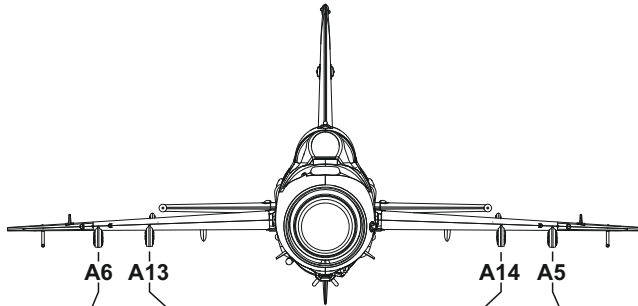

S-24

|| C38



|| C38



|| C38



|| C38



RS-2US

|| C38



|| C38



|| C38



|| C38



R-3S

|| C5



|| C5



|| C45



|| C45



R-13

|| C23



|| C23



|| C28



|| C28



R-60

|| C6



|| C39



FAB 250 BOMB



UB-16



A c/n 9668143, 3. Eskadra Lotnicza Taktycznego (3rd Squadron of the Tactical Air Force), Poznań-Krzesiny, Poland, 2002

3..ELT was formed on January 1st, 2001 in Poznan-Krzesiny, equipped with the MiG-21MF, bis and UM. The MiG-21MF was operated for only two years, with service with this unit ending in 2002. Krzysztof Gladkij is the author of the swordfish artwork painted on both sides of the fuselage and the tail surfaces on the occasion of the unit's 45th anniversary. He supplemented the artwork on the tail surfaces with the inscriptions "Fishbed" (NATO codename for the MiG-21) and "45 lat" (45 years). In the following years the artwork was subject to several modifications. Currently, this aircraft can be seen at Aeroklub Poznański in Kobylnica.



B No. 5212, MiG-21MF, 2nd Fighter Squadron, 11th Fighter Regiment, Zatec Air Base, Czechoslovakia, October 1991

This MiG-21MF was delivered by the Moscow facility to the Czechoslovak Air Force in March 1972 and served with the 4th, 5th and 9th slp. In May 1991, it found its way to the 11th slp. During the same year, the aircraft underwent a general overhaul and in the process received an application of silver paint overall, giving the 2nd Flight techs an opportunity to apply markings commemorating the 40th anniversary of the unit, an opportunity they took advantage of. This look of the aircraft has survived to today. After the disbandment of the 11th slp., the aircraft was reassigned to the 28th sbolp., based at Čáslav, where it served until its retirement in 2002, after which it was mounted on a pedestal to serve as a memorial.

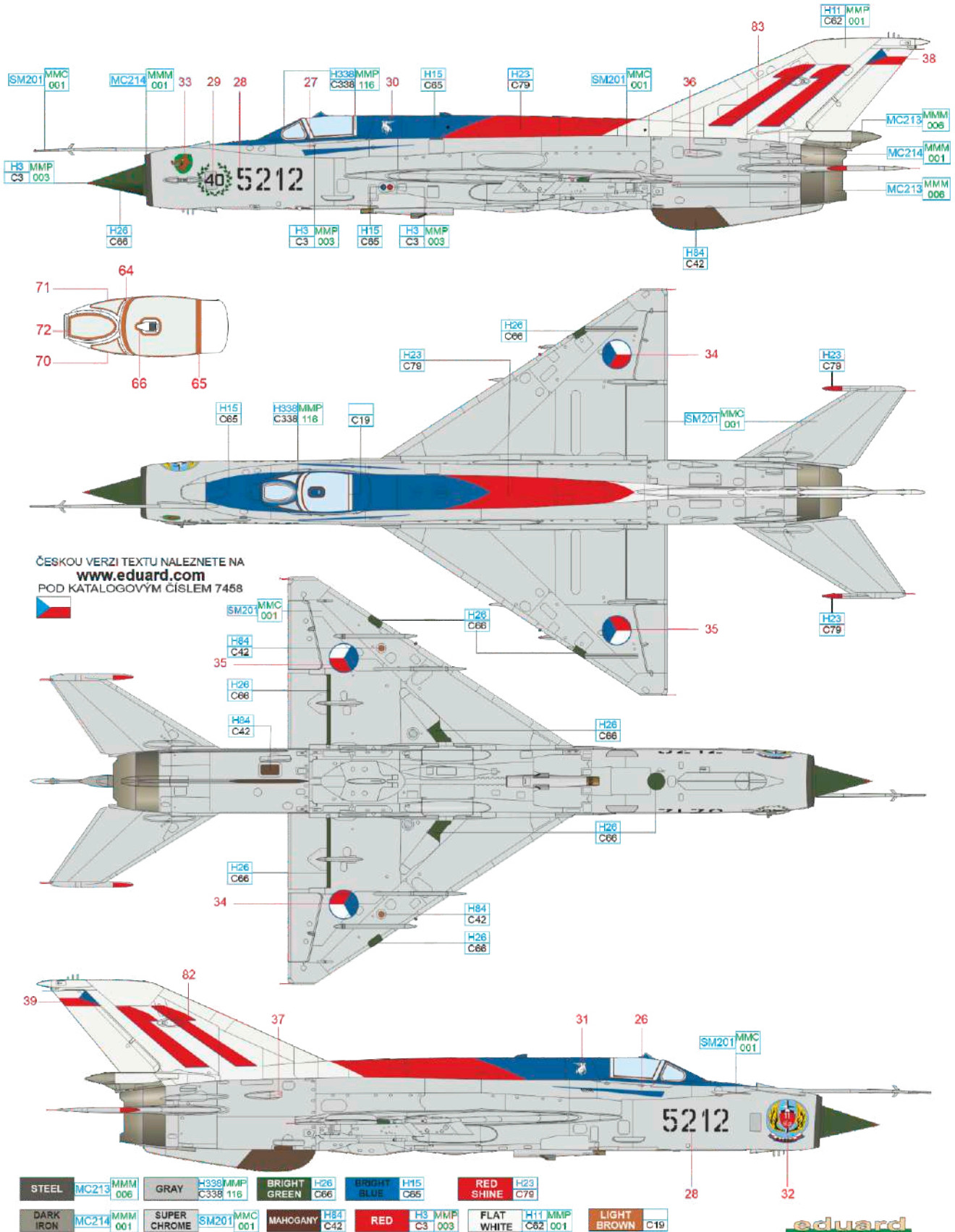

C Jagdfliegergeschwader 3, Preschen AB, German Democratic Republic, 1990

Red '687' was assigned to JG-3 based at Preschen Air Base near the town of Forst through the eighties and into the nineties. At that time, the unit operated the MiG-21MF as well as MiG-29s, and pilots also had the MiG-21UM and MiG-29UB available for training flights. The unit served the German Democratic Republic, also known as East Germany, and was graced with the name 'Wladimir Komarow', in honor of the Soviet cosmonaut who died on April 24, 1967, during landing on return from orbit of the Soyuz 1 capsule. This aircraft is part of the collection of the Deutsches Museum Flugwerft in Oberschleissheim.

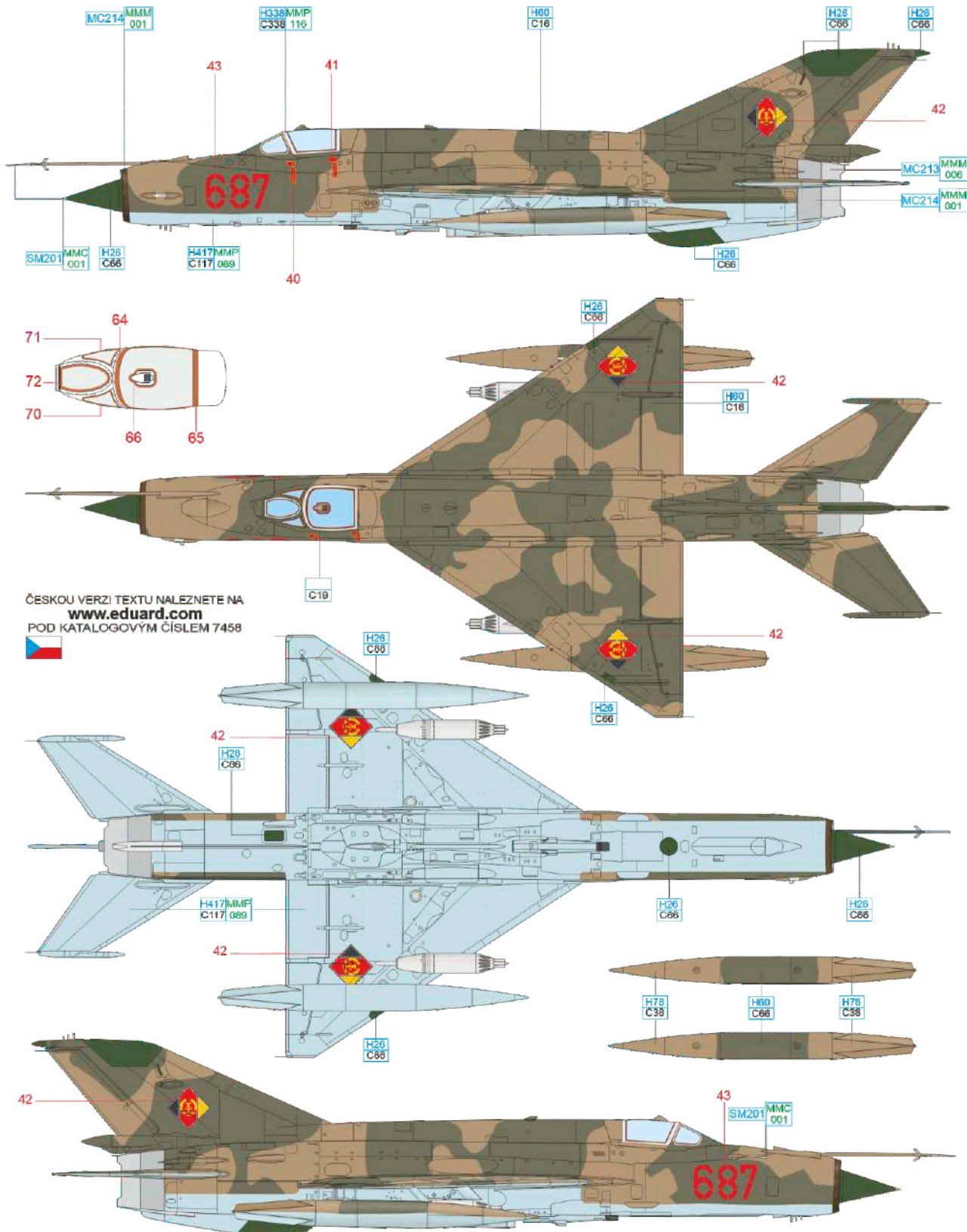

ČESKOU VERZI TEXTU NALEZNETE NA
www.eduard.com
 POD KATALOGOVÝM ČÍSLEM 7458



STEEL	MC213	MMM 008	LIGHT GRAY	H338	MMP C338 116	LIGHT BLUE	H417	MMP C117 089
DARK IRON	MC214	MMM 001	BRIGHT GREEN	H26	C66	OLIVE DRAB	H78	C38
						DARK GREEN	H60	C16
							LIGHT BROWN	C19
						SUPER CHROME	SM201	MMC 001

D No. 7628, Egyptian Air Force, Tanta AB, Arab Republic of Egypt, 1988

Aircraft No.7628 represents the appearance of Egyptian military aircraft that are known through to the present day. The black outlined bright orange fields appeared on Egyptian aircraft at the end of the seventies, not only on the MiG-21s, but also on other fighters such as the MiG-19, F-4 Phantom and Mirage. The reason for this practice was better visual recognition of friendly aircraft in combat during the war with Libya.

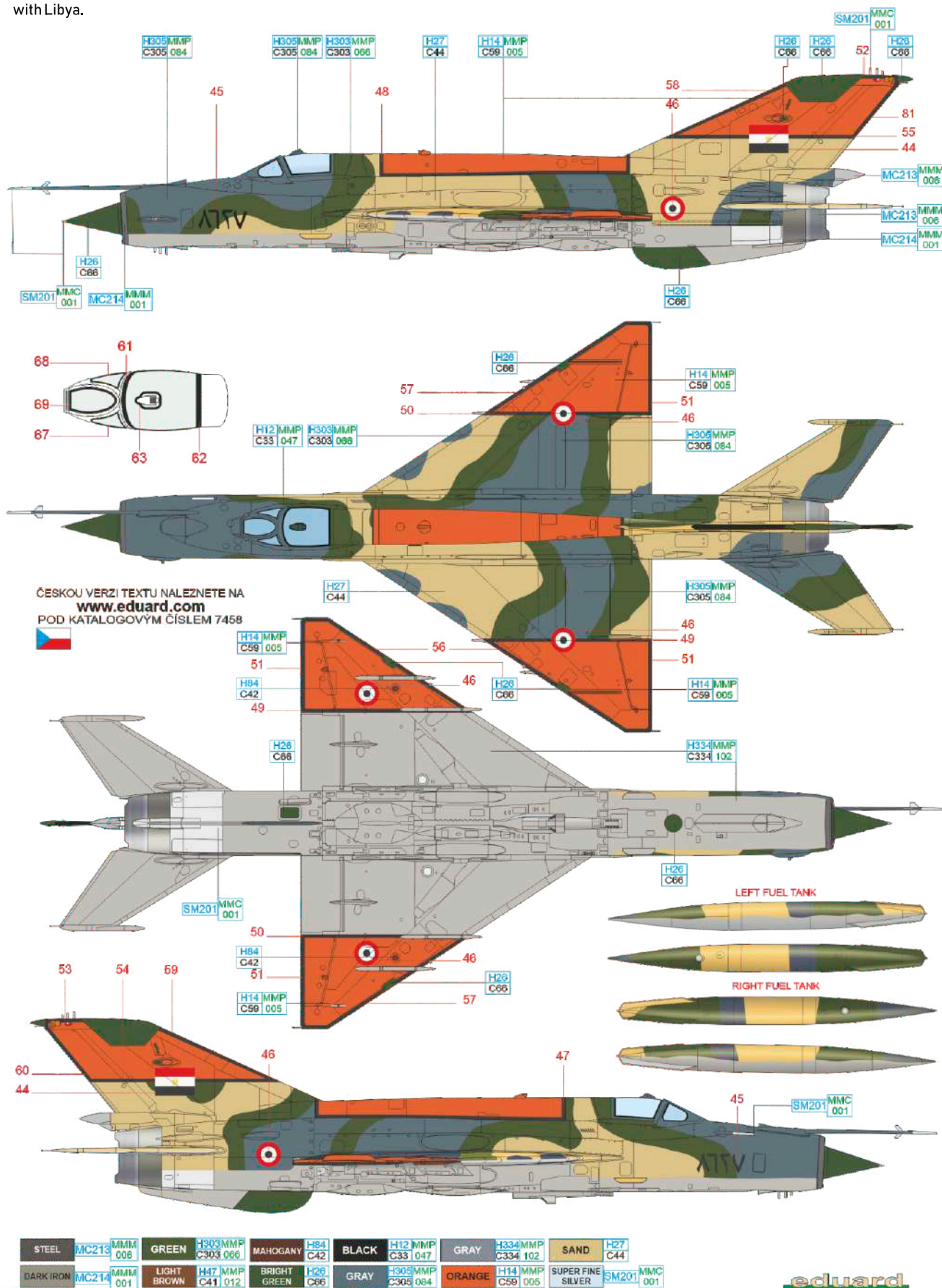

SN - SERIAL NUMBER

SMAL TO AIRFRAME

MEDIUM TO PYLONS

LARGE TO ROCKET LAUNCHERS

LEFT OUTSIDE UNDERWING TANK PYLON

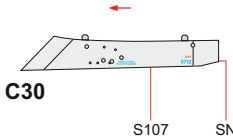

FUSELAGE PYLON

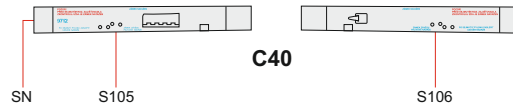

RIGHT OUTSIDE UNDERWING TANK PYLON

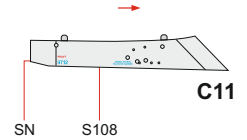

LEFT OUTSIDE PYLON

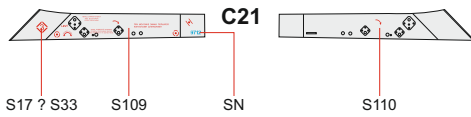

RIGHT OUTSIDE PYLON

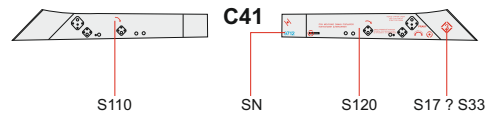

LEFT INSIDE PYLON

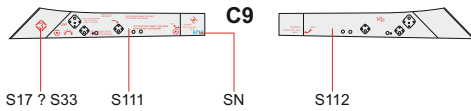

RIGHT INSIDE PYLON

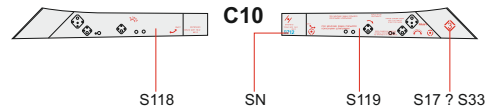

C38

APU-7

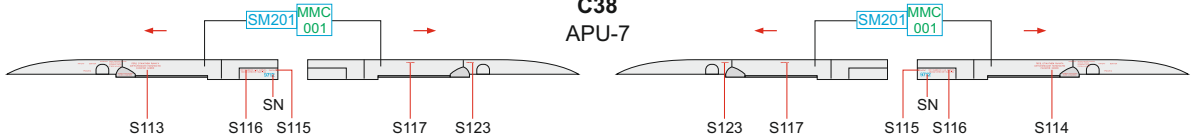

C5, C45

APU-13

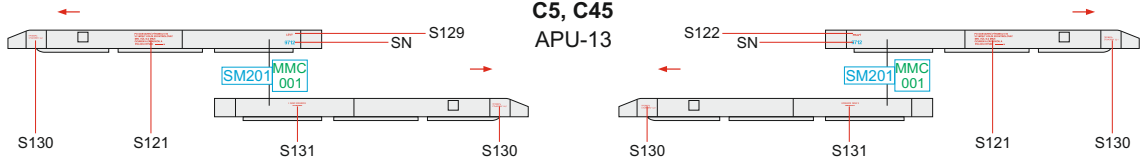

C23, C28

APU-13MT

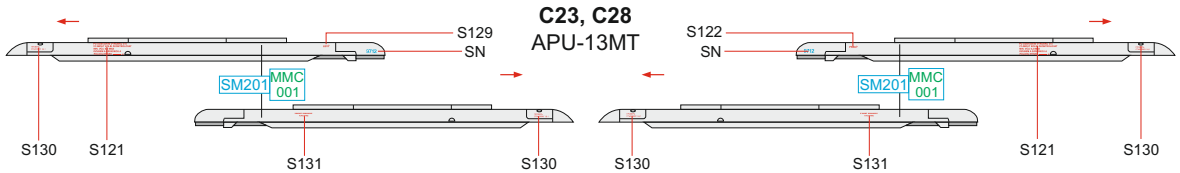

C12, C14, C37, C44

APU 2xR60

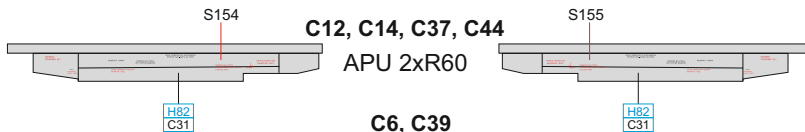

C6, C39

APU FOR R-60

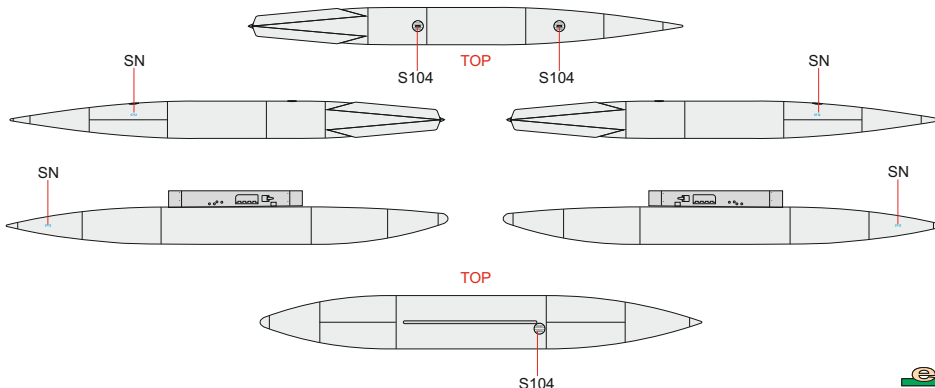
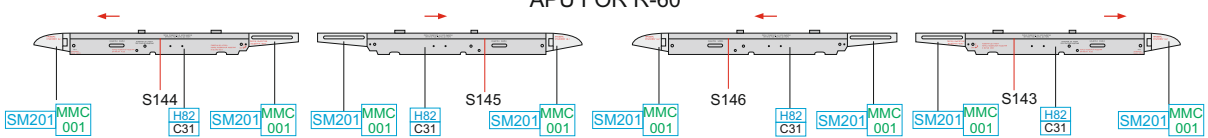

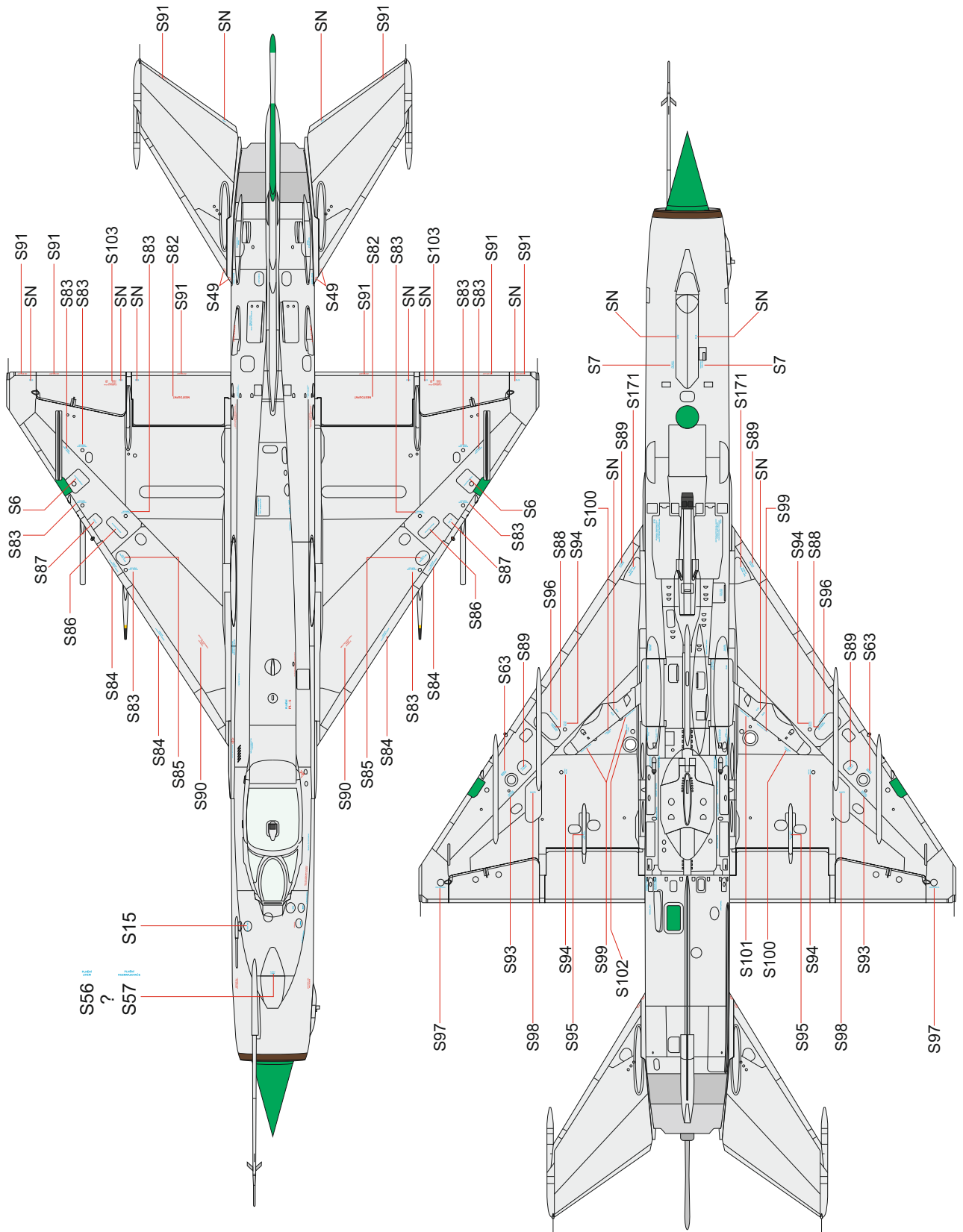

Red and blue stencils for camouflaged aircraft, black and red for grey or natural metal aircraft.

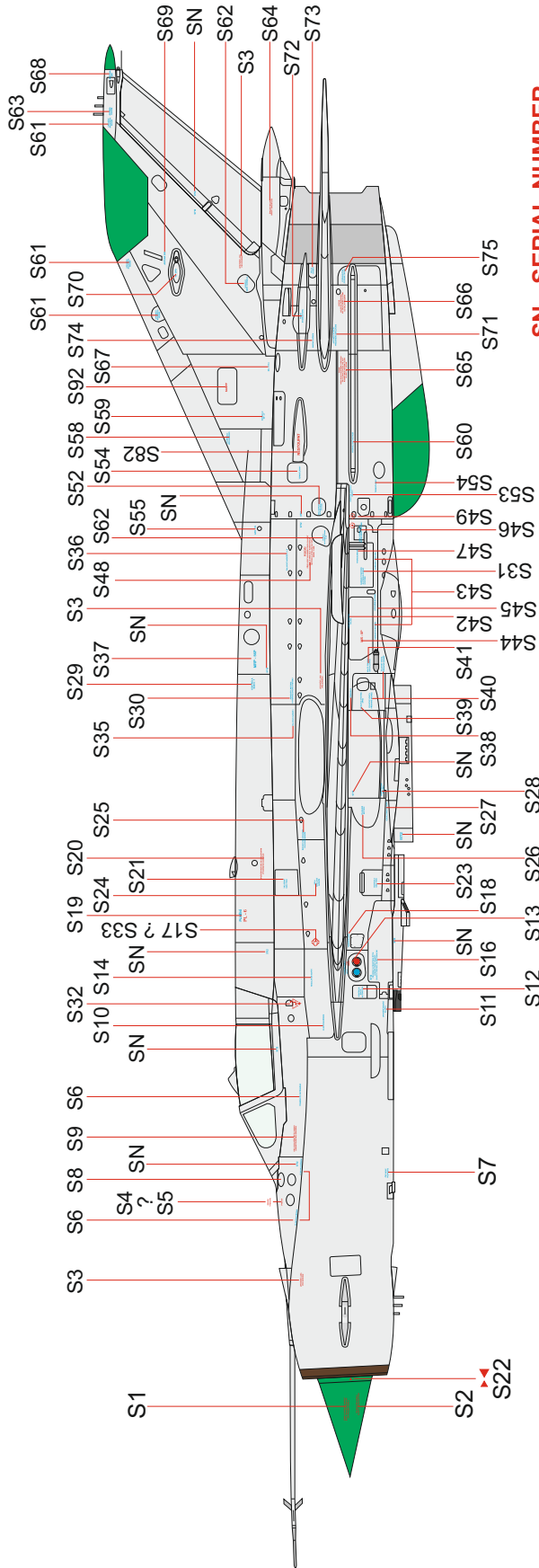

SN - SERIAL NUMBER
 SMALL TO AIRFRAME
 MEDIUM TO PYLONS
 LARGE TO ROCKET LAUNCHERS

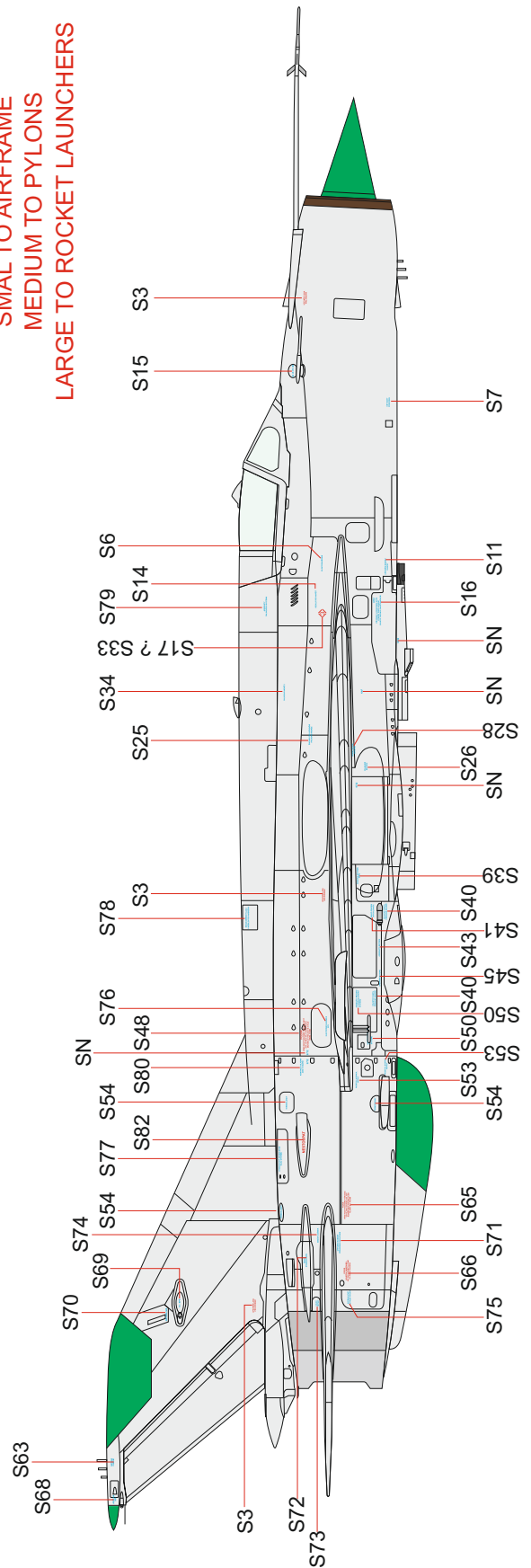

Eduard goodies for MiG-21MF Fighter Bomber 1/72

- 72689 MiG-21MF (PE-Set)
- 672179 MiG-21MF Fighter Bomber cockpit (Brassin)
- 672181 MiG-21MF exhaust nozzle (Brassin)
- 672182 MiG-21MF wheels (Brassin)
- 672184 MiG-21MF pylons (Brassin)
- 672185 R-3S missiles for MiG-21 (Brassin)
- 672186 R-3S missiles w/ pylons for MiG-21 (Brassin)
- 672189 UB-16 rocket launchers for MiG-21 (Brassin)
- 672190 UB-16 rocket launchers w/ pylons for MiG-21 (Brassin)
- 672191 RS-2US missiles for MiG-21 (Brassin)
- 672192 RS-2US missiles w/ pylons for MiG-21 (Brassin)
- 672193 MiG-21MF airbrakes (Brassin)
- 672195 SPS-141 ECM pod for MiG-21 (Brassin)
- 672197 MiG-21MF ejection seat (Brassin)
- SIN67216 MiG-21MF Fighter-Bomber (Brassin)
- SIN67217 MiG-21MF armament (Brassin)
- 3DL72002 MiG-21MF SPACE (3D Decal Set)
- D72015 MiG-21MF stencils (Decal Set)
- CX512 MiG-21MF TFace (Mask)

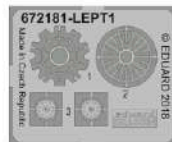
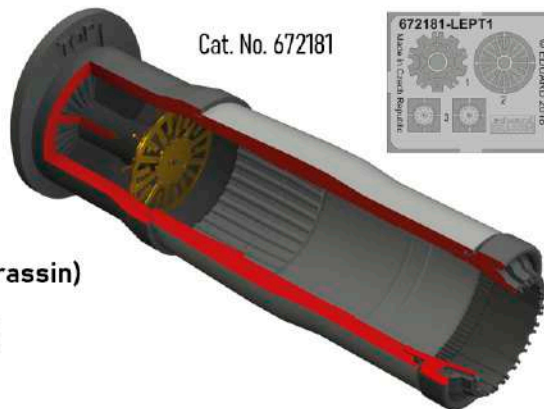

Cat. No. 672190



Cat. No. 672182



Cat. No. 672190



Cat. No. 672182



Cat. No. 672179

