



PZL.37B

1:72 Scale

72042



The PZL.37 Łoś (moose) was a Polish twin-engine medium bomber designed and manufactured by national aircraft company PZL.

Production of the Łoś commenced during the winter of 1936-1937.

General characteristics

Crew:	4
Length:	12.92 m (42 ft 5 in)
Wingspan:	17.93 m (58 ft 10 in)
Height:	5.1 m (16 ft 9 in)
Wing area:	53.5 m ² (576 ft ²)
Empty weight:	4,280 kg (9,436 lb)
Loaded weight:	8,865 kg with basic combat loading (19,526 lb)
Max takeoff weight:	9,105 kg (20,070 lb)
Powerplant:	2 × Bristol Pegasus radial engines, 723 kW (970 hp) each

Performance

Maximum speed:	412 km/h at 2,800 m with 1,995 kg bomb load (256 mph at 9200 ft with 4,397 lb bomb load)
Range:	2,600 km (1,615 mi) with 1,760 kg bomb load and extra fuel tanks
Combat radius:	1,000 km (620 mi)
Service ceiling:	7,000 m (23,000 ft)
Rate of climb:	4.7 m/s (925 ft/min)
Wing loading:	166 kg/m ² (34 lb/ft ²)

Armament

3 x 7.92 mm observer's machine gun: 1 in the nose, 1 in the rear upper station, 1 in underbelly station
Up to 2,580 kg (5,690 lb) of bombs (18 x 110 kg + 2 x 300 kg). Basic load 20 x 110 kg = 2,200 kg (4850 lb)
Bomb load while operating from unprepared fields 880–1320 kg (1,940–2,910 lb) (8, 10 or 12 x 110 kg)

Source:- Wikipedia

SYMBOLS

Drill hole



Vyvrtať

Cyanoacrylate



Vtiefinové lepidlo

Remove



Odfíznout

Reduce



Zbrousit

Make new



Vyrobit

Option



Voiba

Bend



Ohnout

PLASTIC PARTS 1

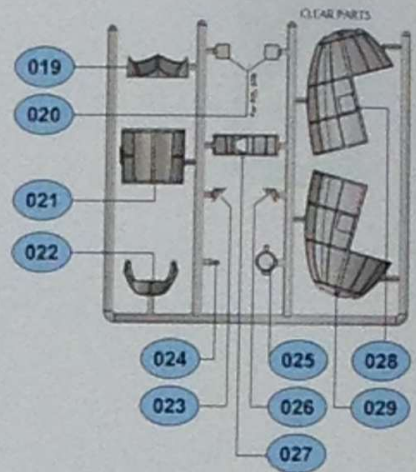
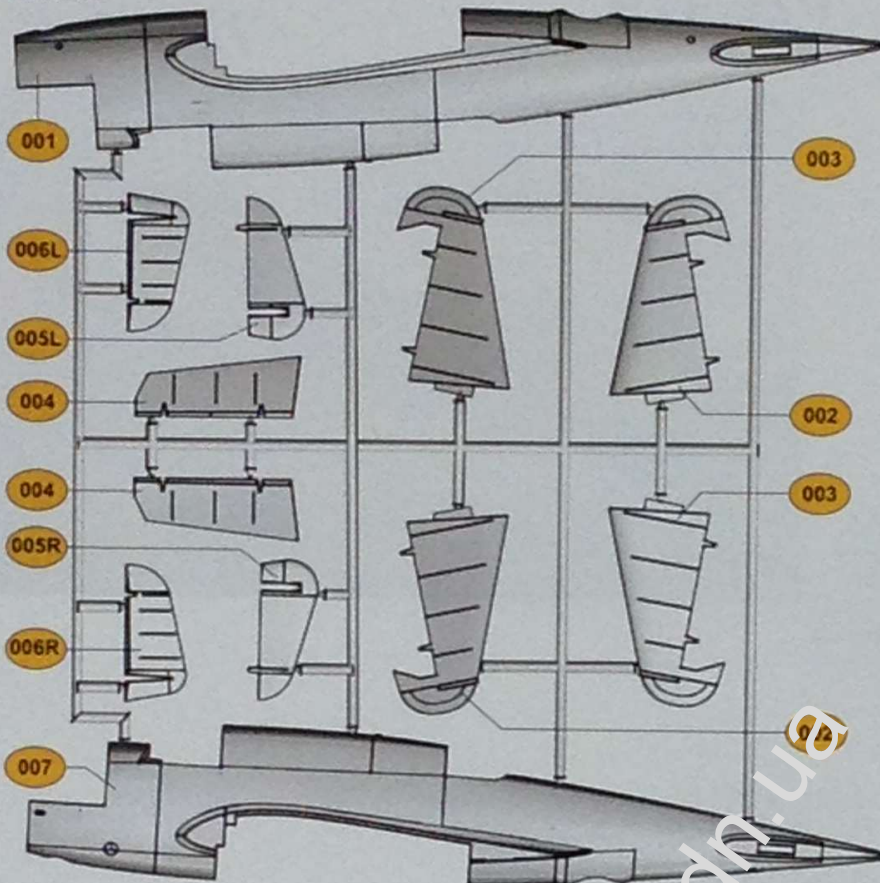

RESIN PARTS

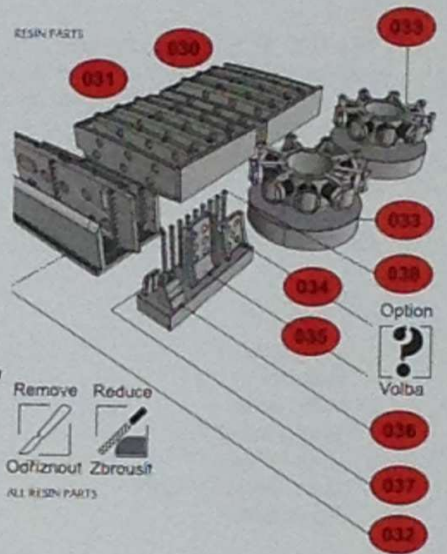

PLASTIC PARTS 2

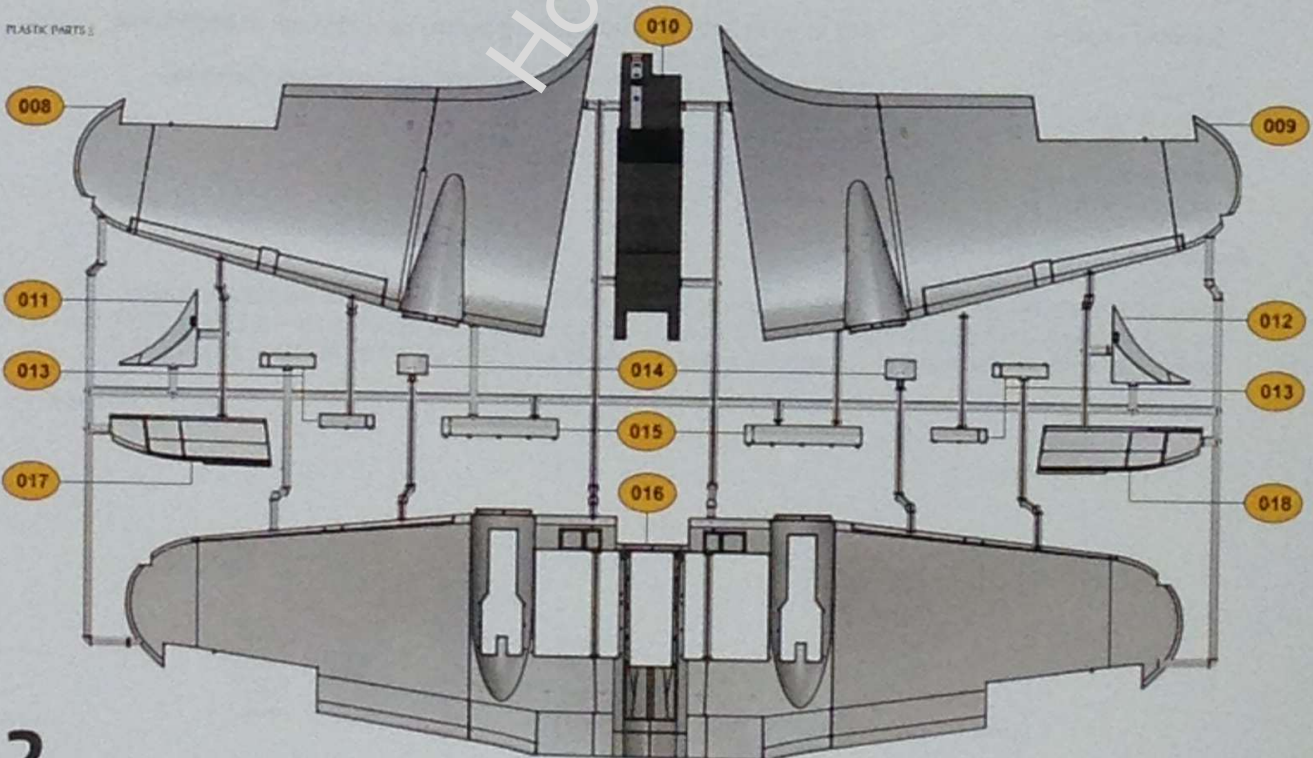

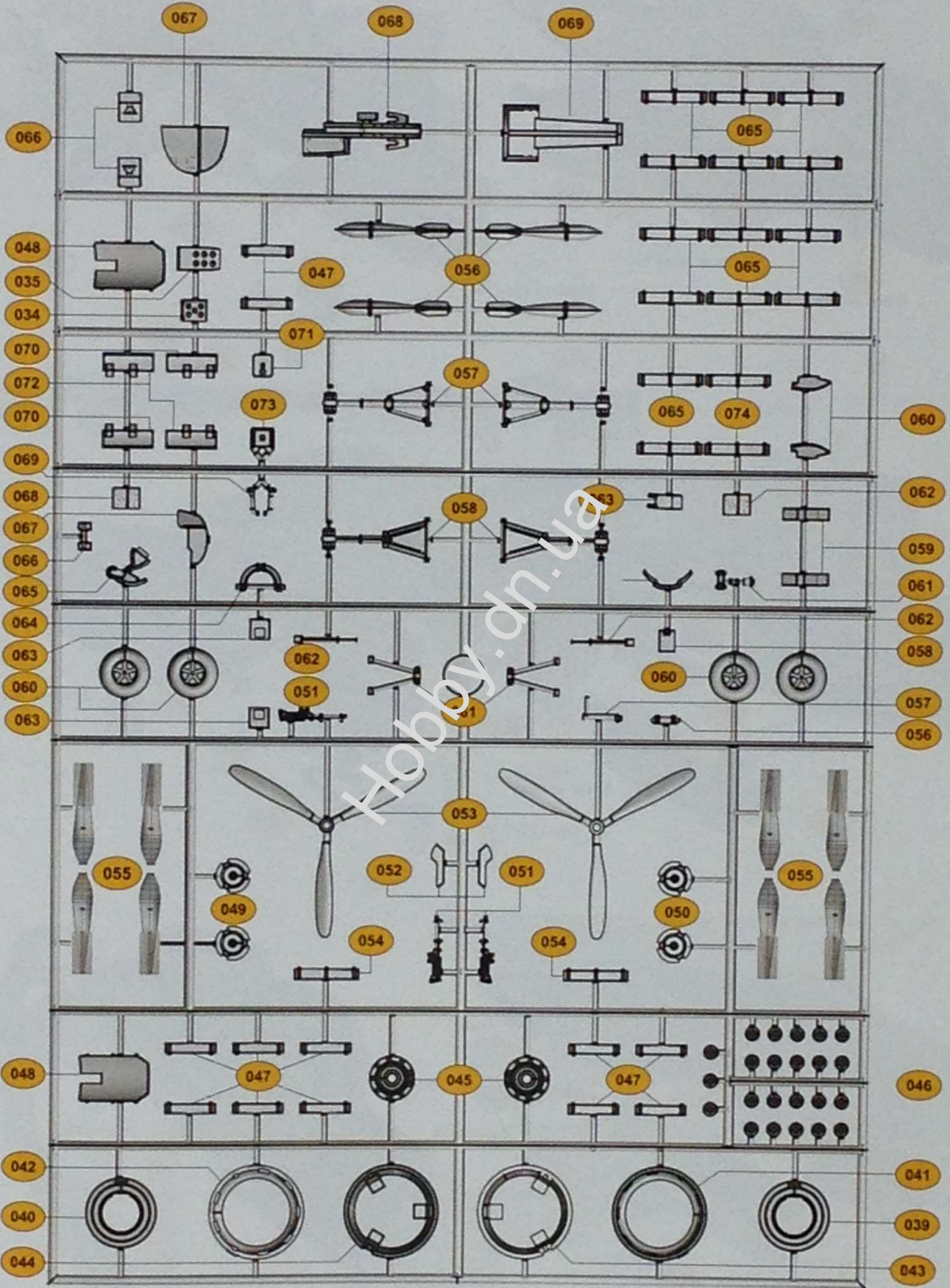

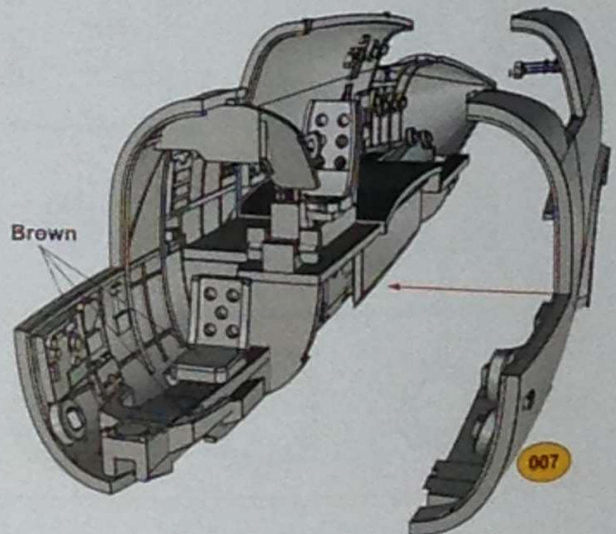
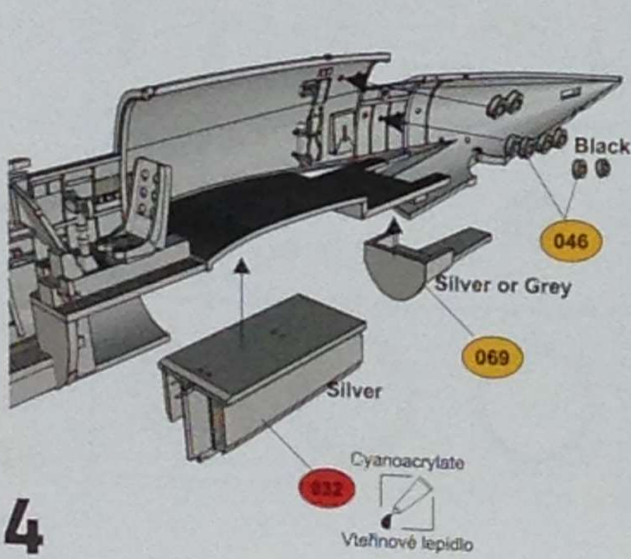
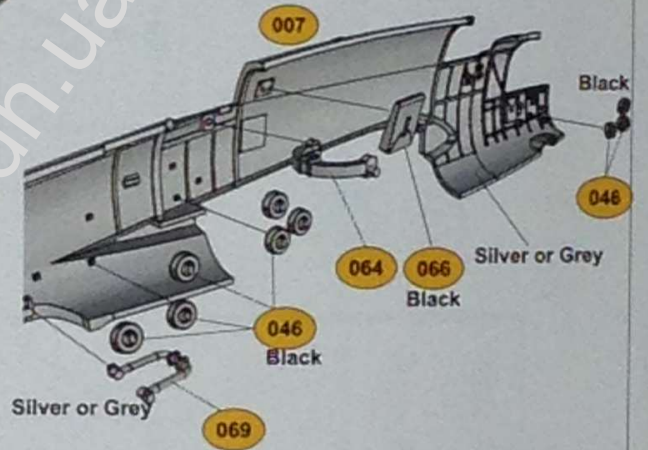
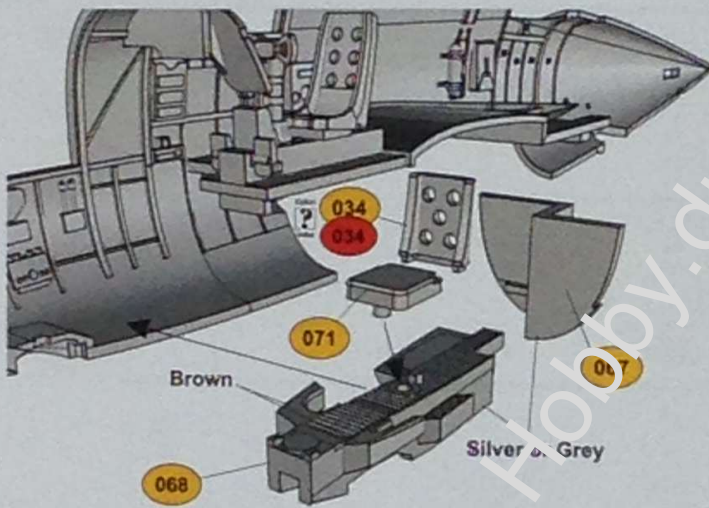
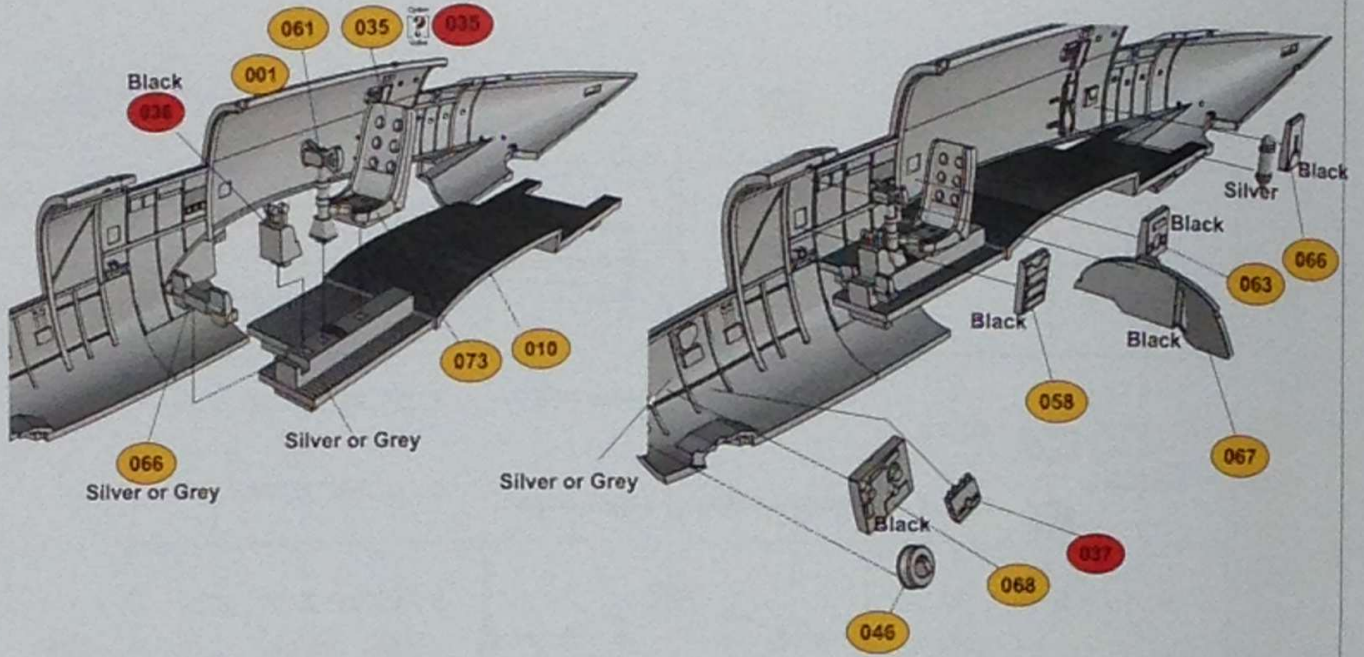

4

Cyanoacrylate
Vteřinové lepidlo

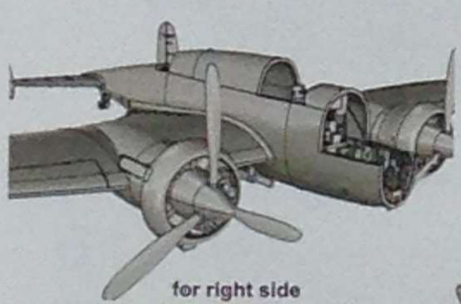
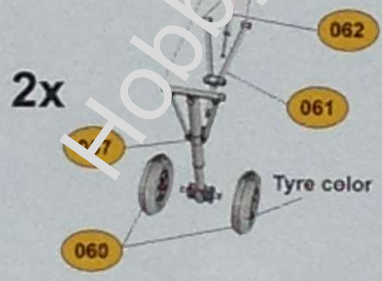
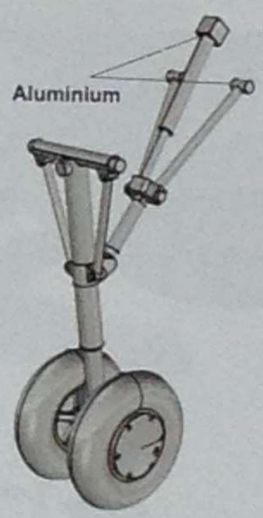
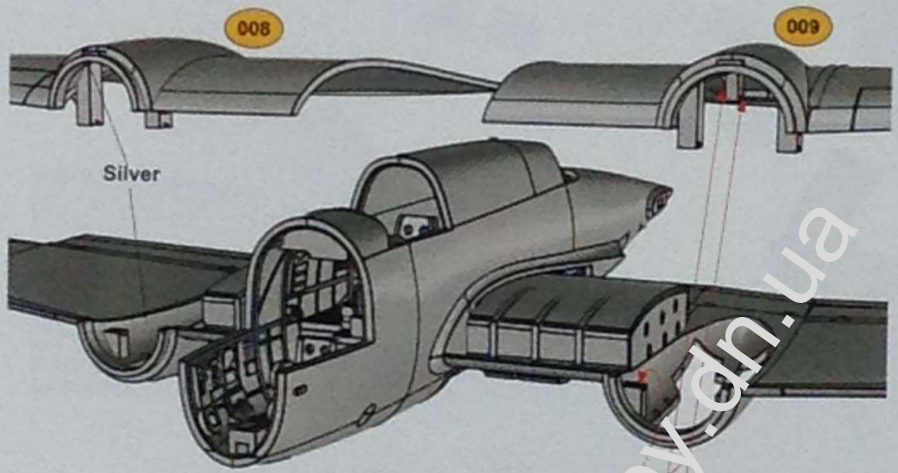
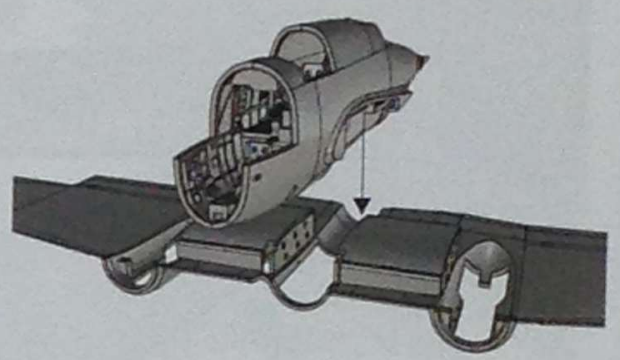
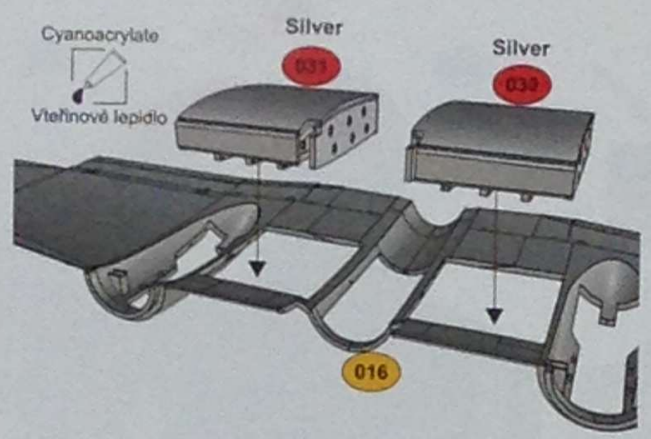

- for right side
- 041 050
 - 033 053
 - 039 059
 - 043 060

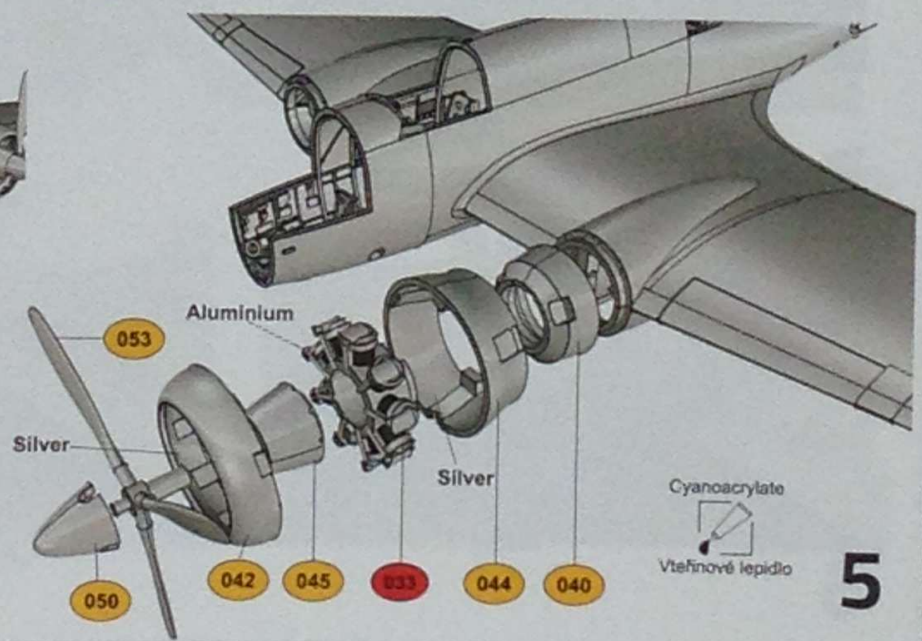

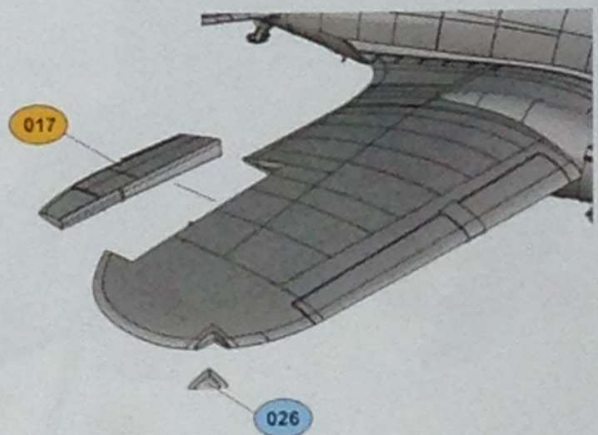
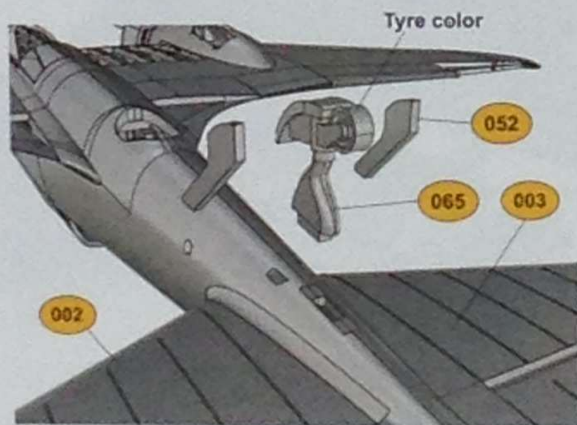
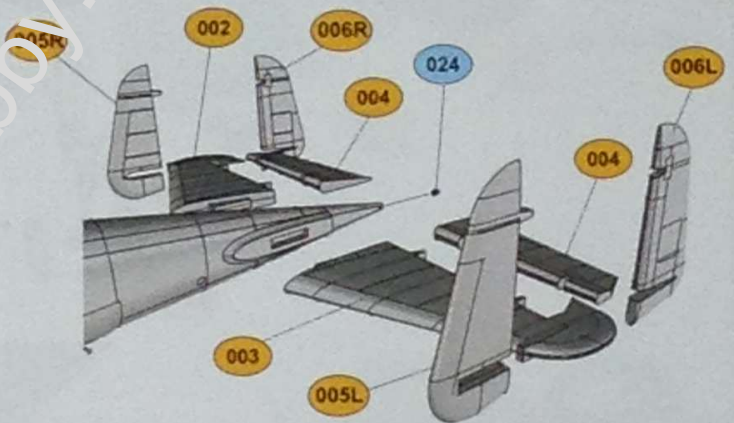
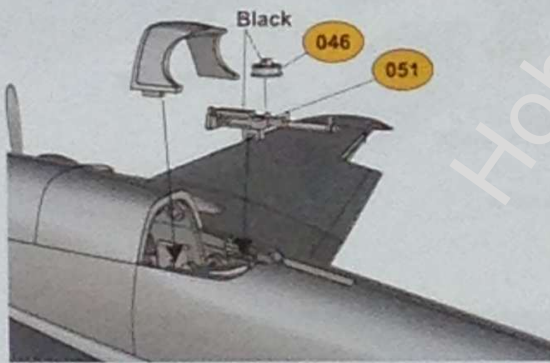
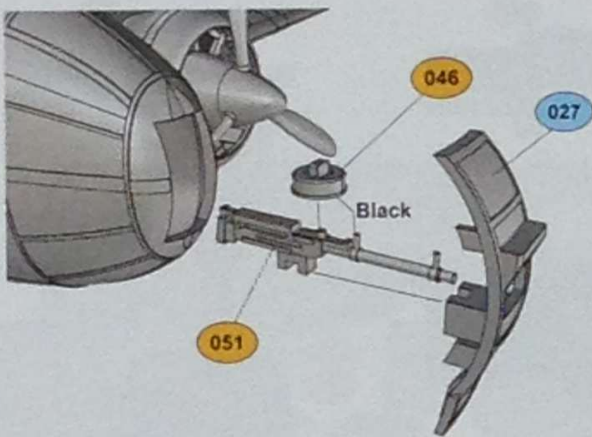
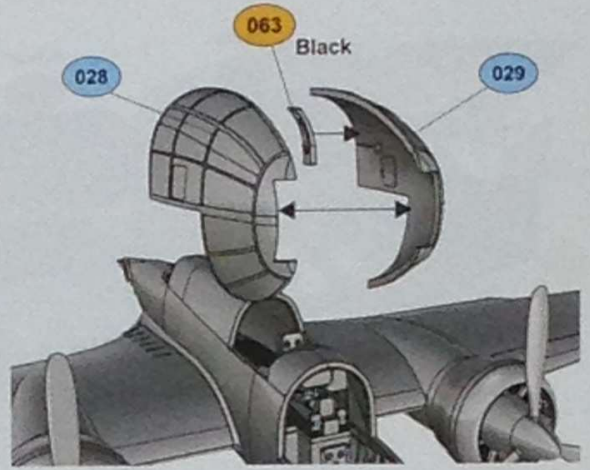
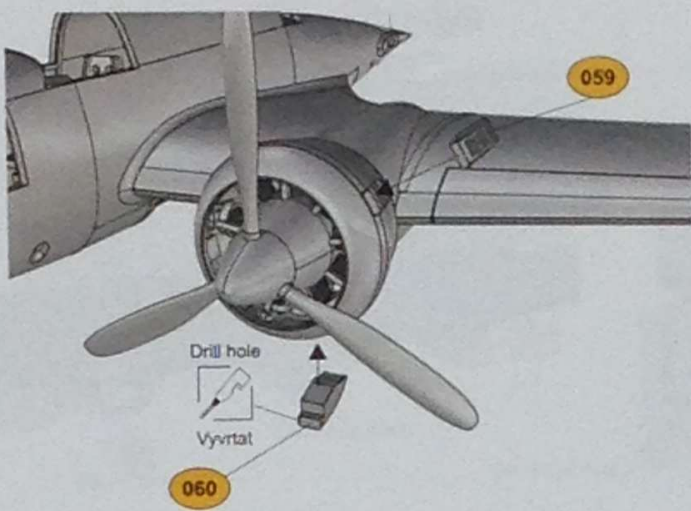

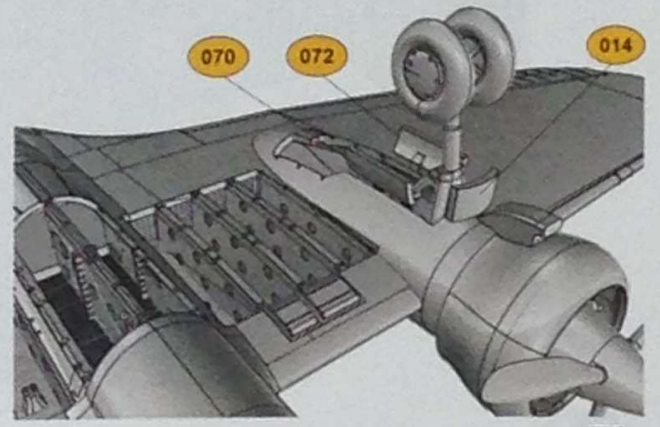
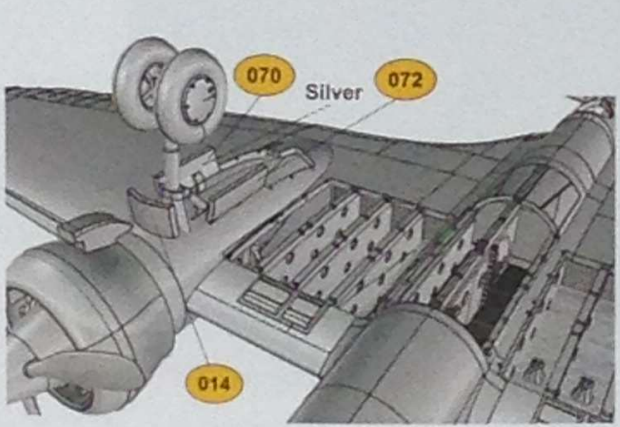
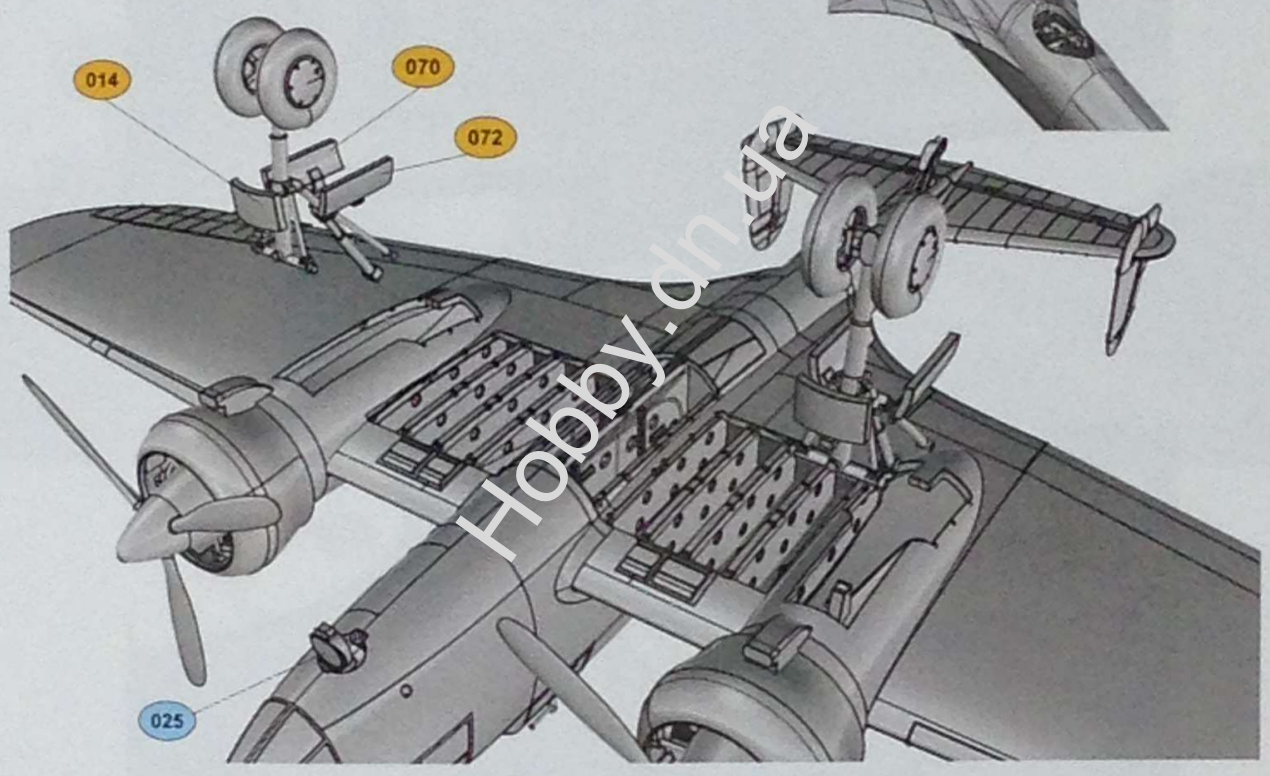
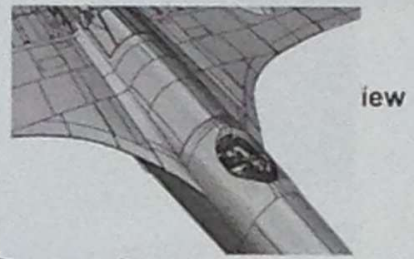
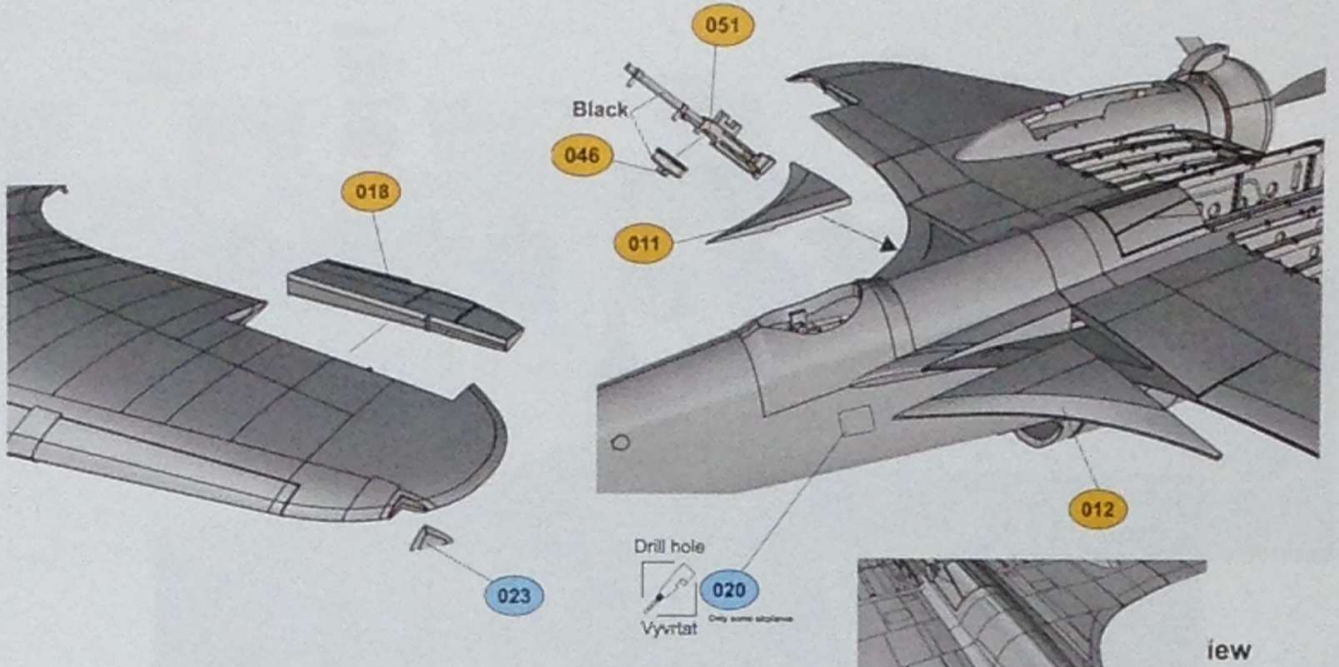

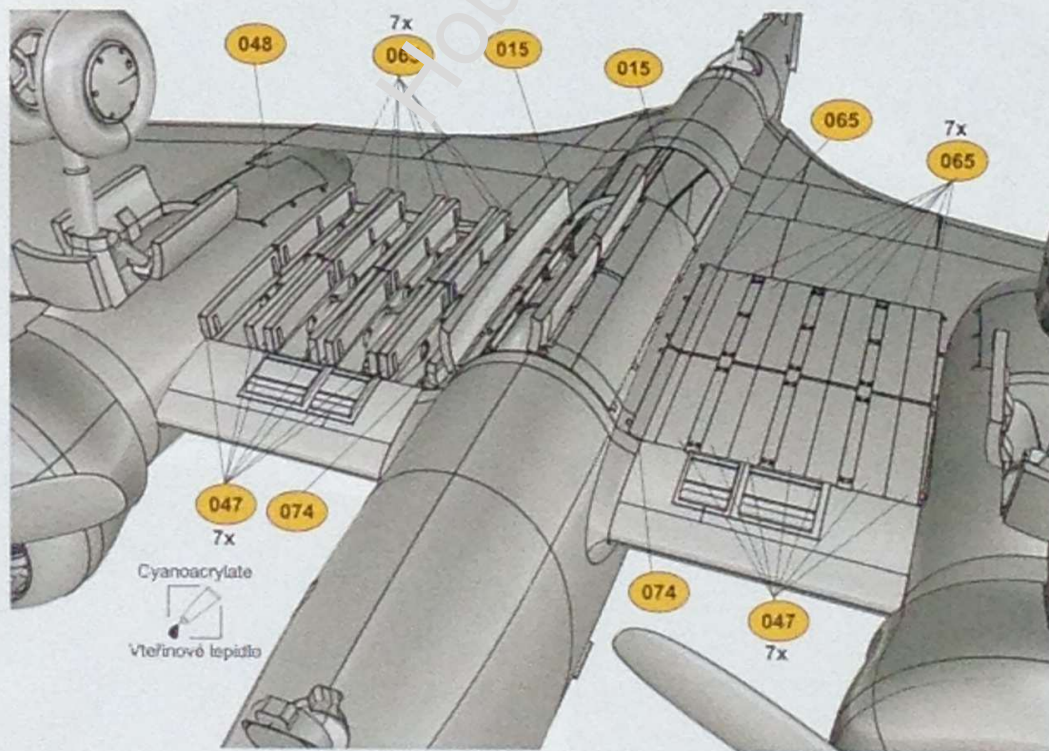
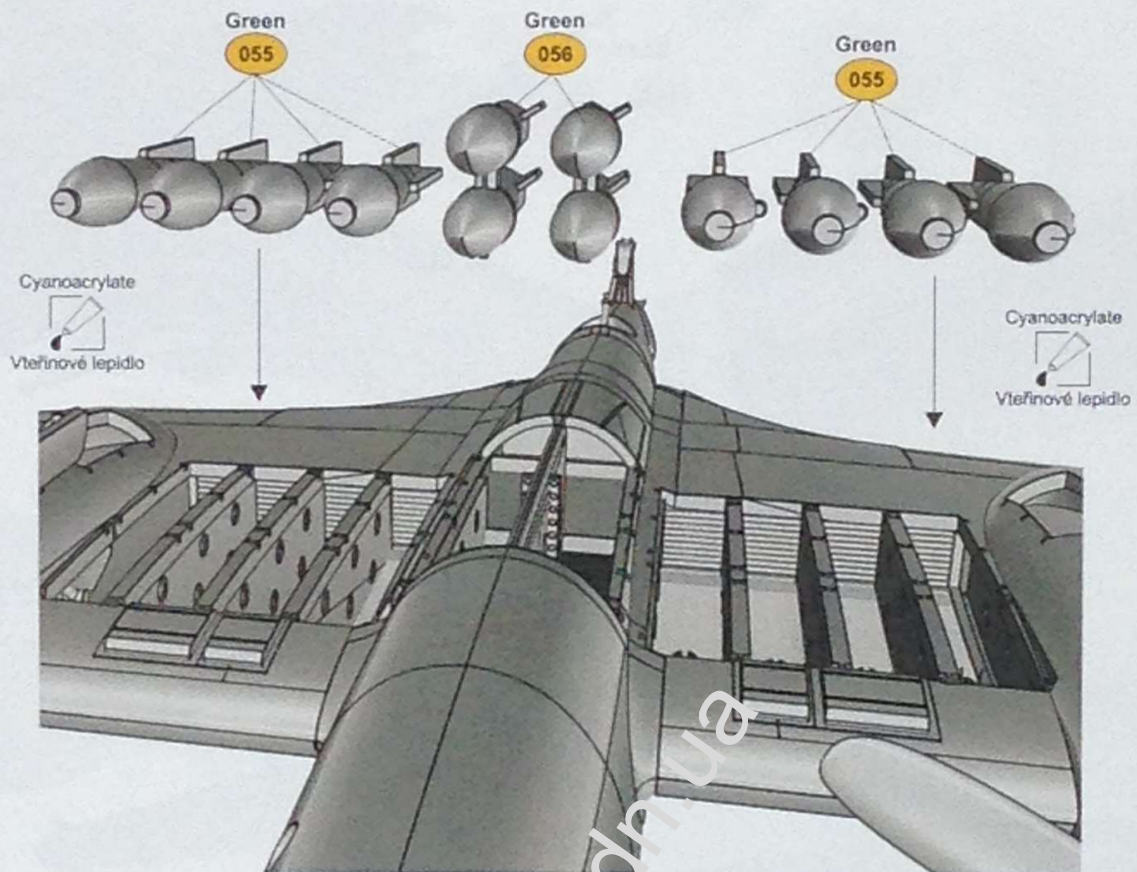

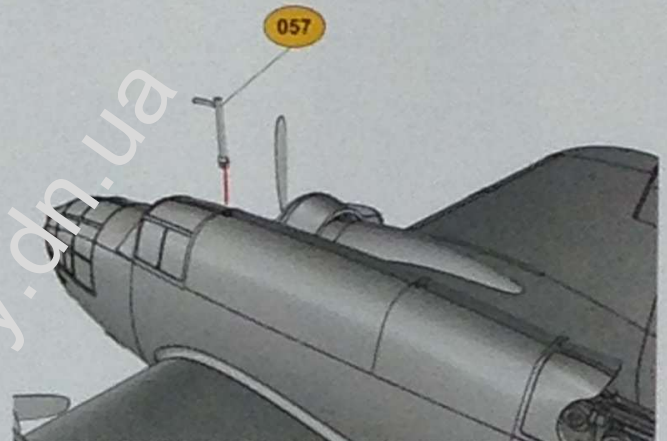
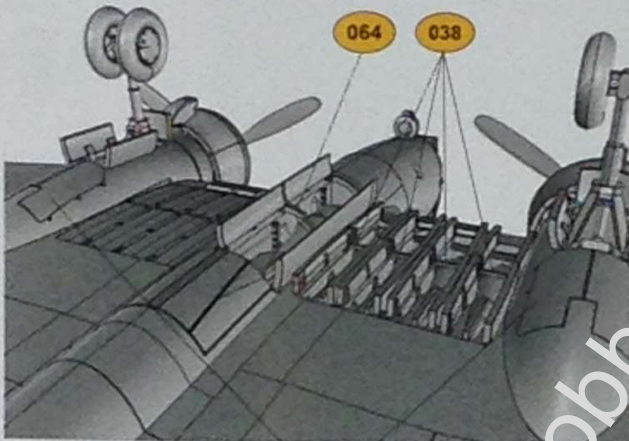
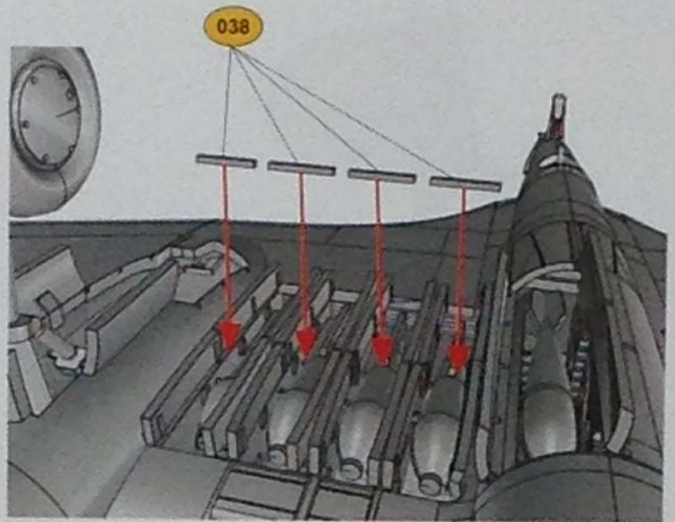
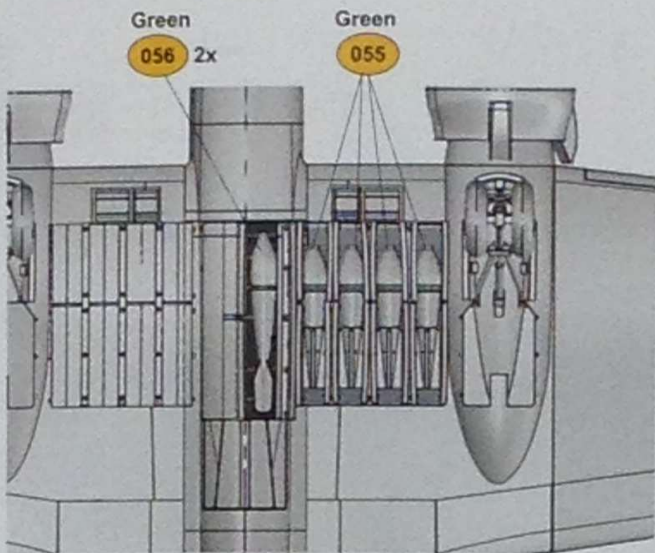

048

Make new



Vyrobít

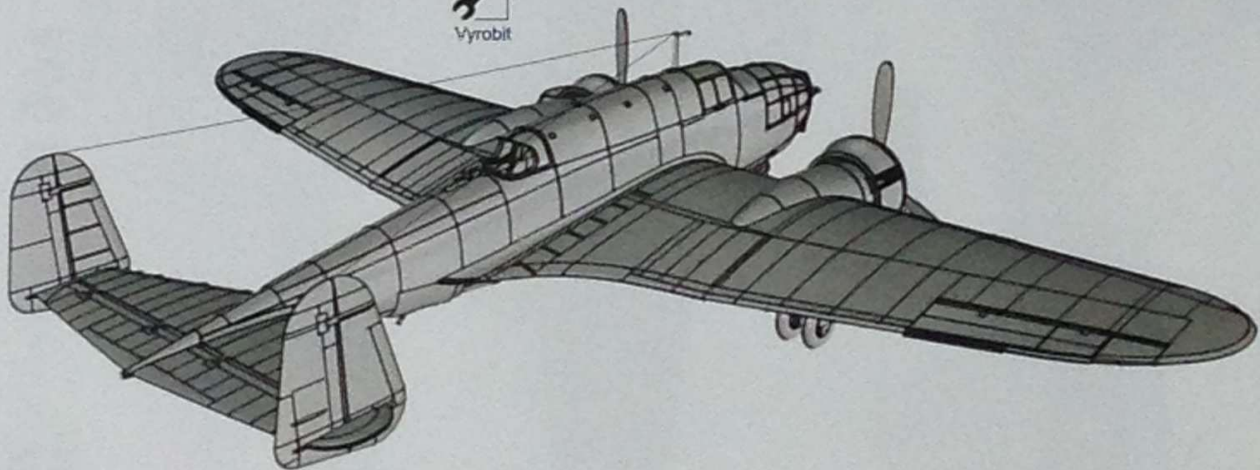

Humbrol	30	29	65	154	155	47	67
	2011	2012	2009	2065	736	4145	2004

PZL.37 B - ŁOŚ B

PH
72042

PZL.37 B ŁOŚ B

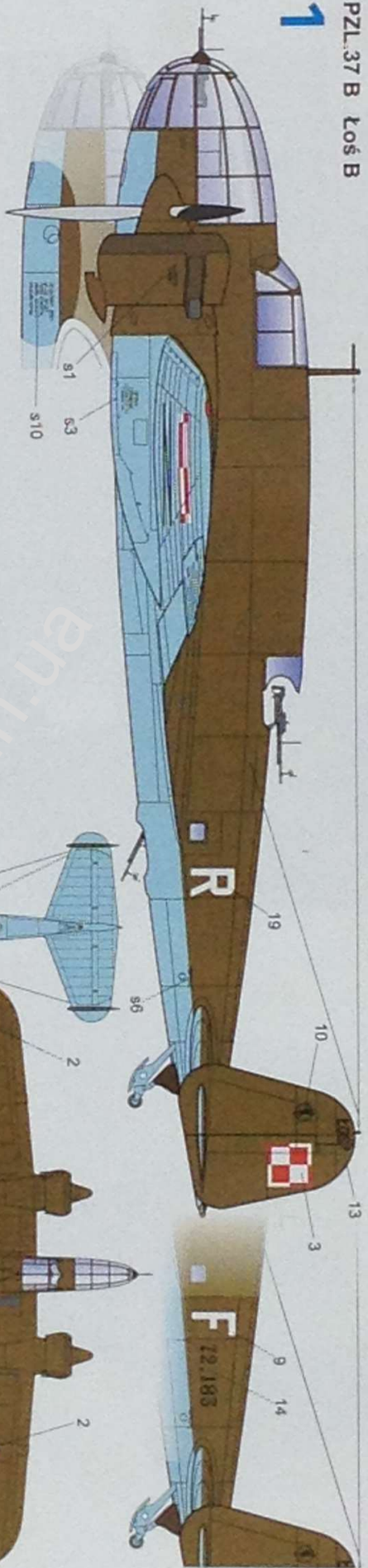

PZL.37 B Łoś, code „R” no. 701 N”, 1st Air Regiment, Warsaw - Okęcie Air, (el/),
 PZL.37 B Łoś, code „F” no. 72.183 of the 16th Bomber Flight.
 On 14 September 1939 the crew of Lt. Piotr Kowalski due
 to lack of fuel it was forced to land in field at Mukoszyn
 near Kamień Koszyrski.

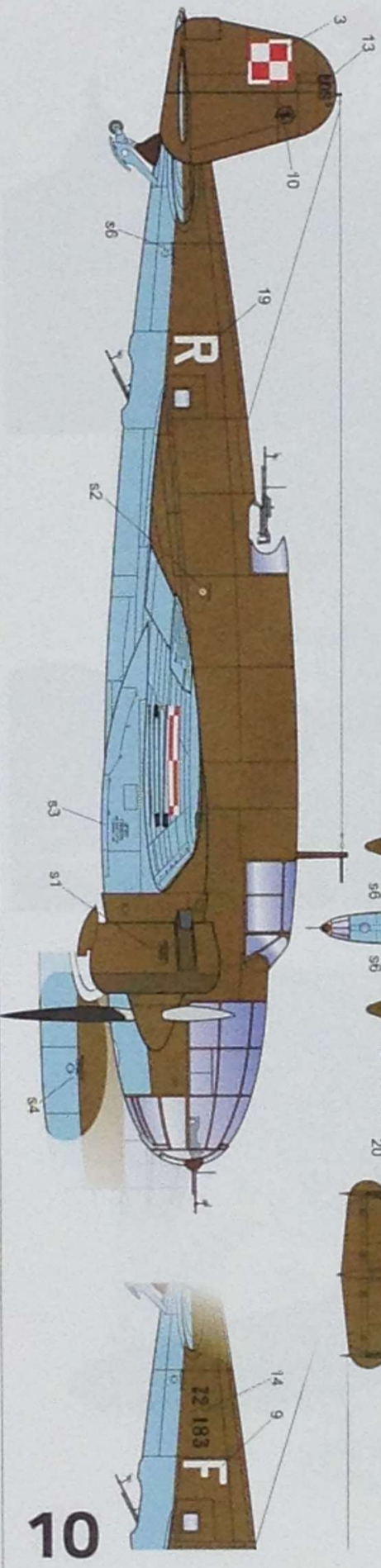
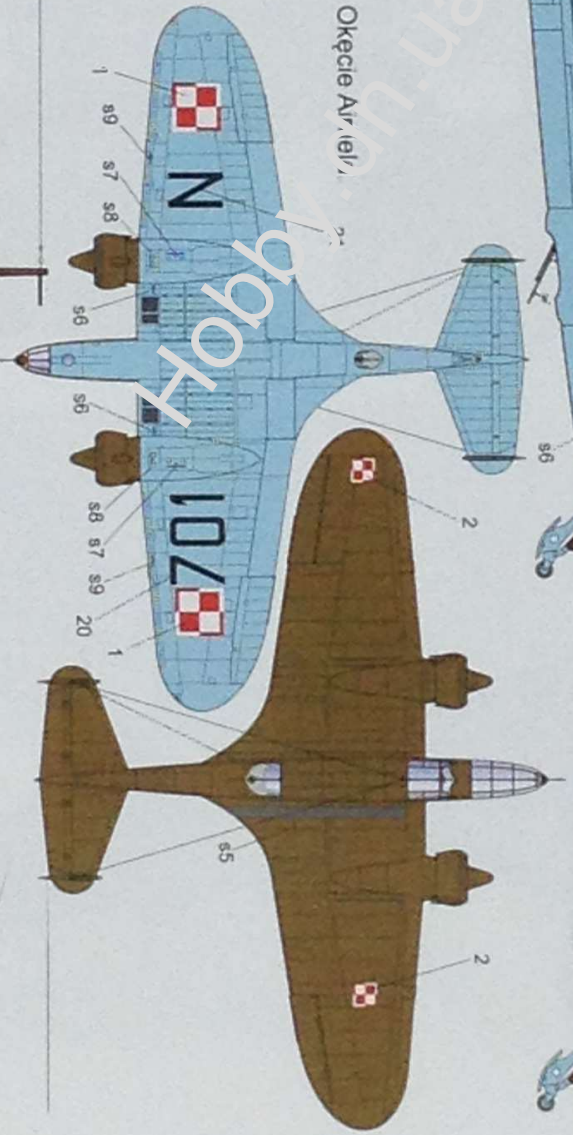

PZL 37 B Łoś B

2

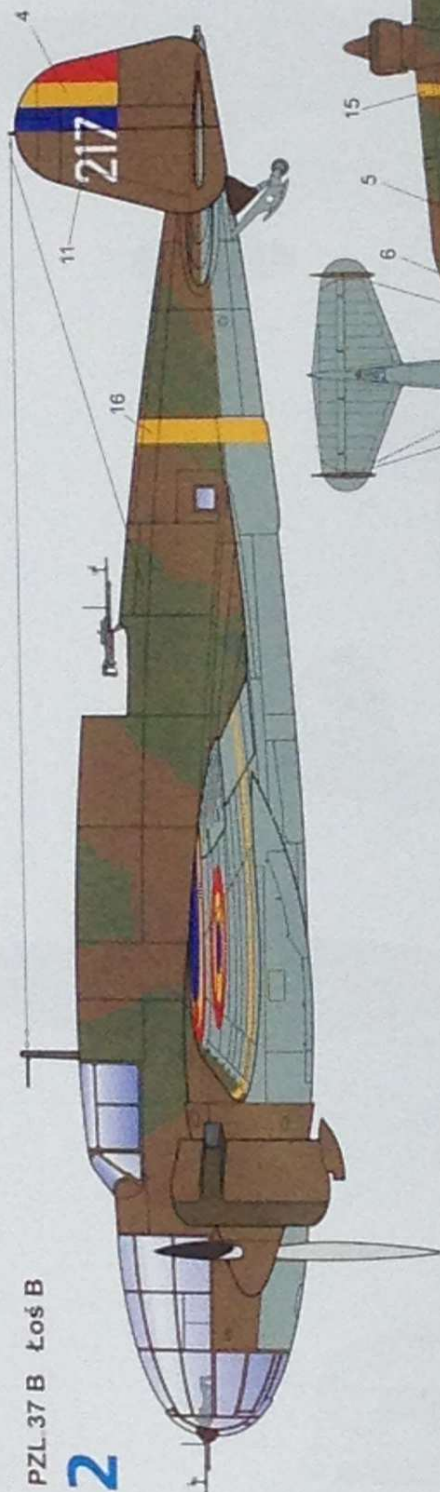

PZL 37 B Łoś B no 217 (ex-72.200) of the Grupul 4 Bombardament ARR based in early 1940 at Blaj (Balázsfalva). AEROPLANE in new, two-tone camouflage with Rumanian national markings and quick recognition markings on wing tips.

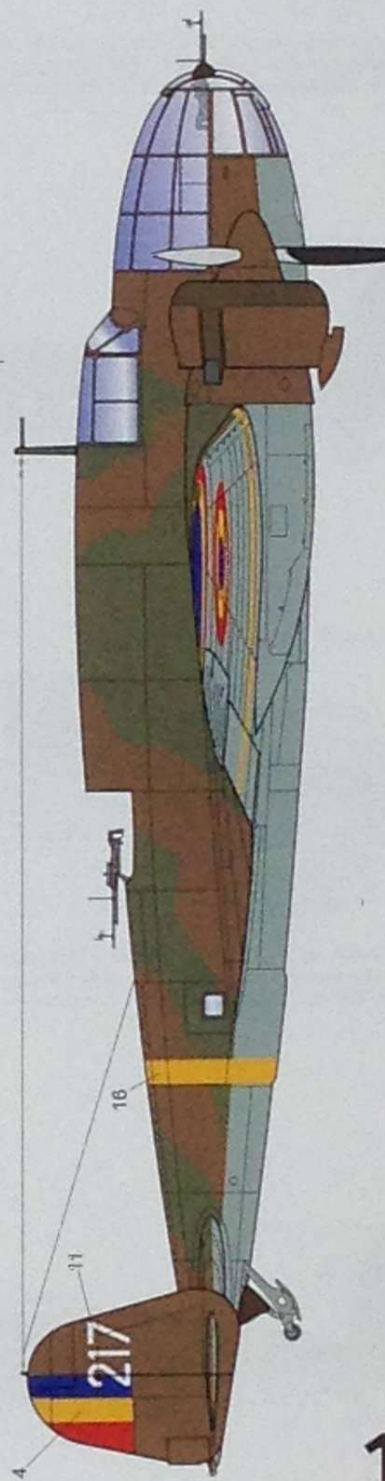

11

Humbrol	155	47	30	65	67
	736	4145	2005	2009	2094

PZL.37 B - łoś B

Flt
72042

PZL.37 B łoś B

3

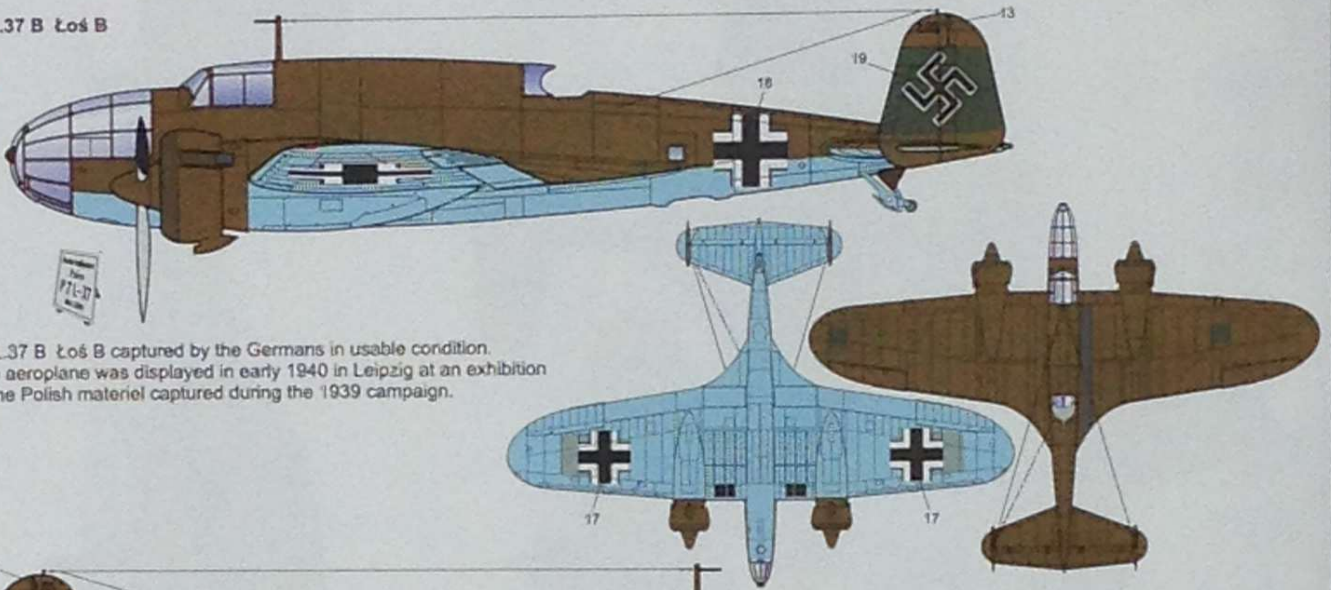

PZL.37 B łoś B captured by the Germans in usable condition. The aeroplane was displayed in early 1940 in Leipzig at an exhibition of the Polish material captured during the 1939 campaign.

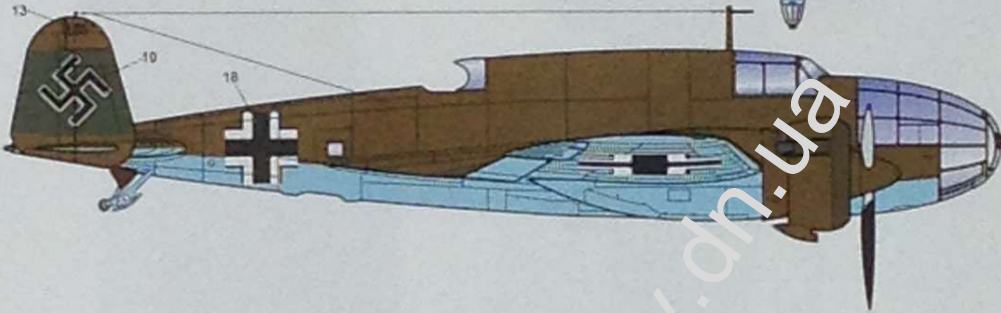

PZL.37 B łoś B

4

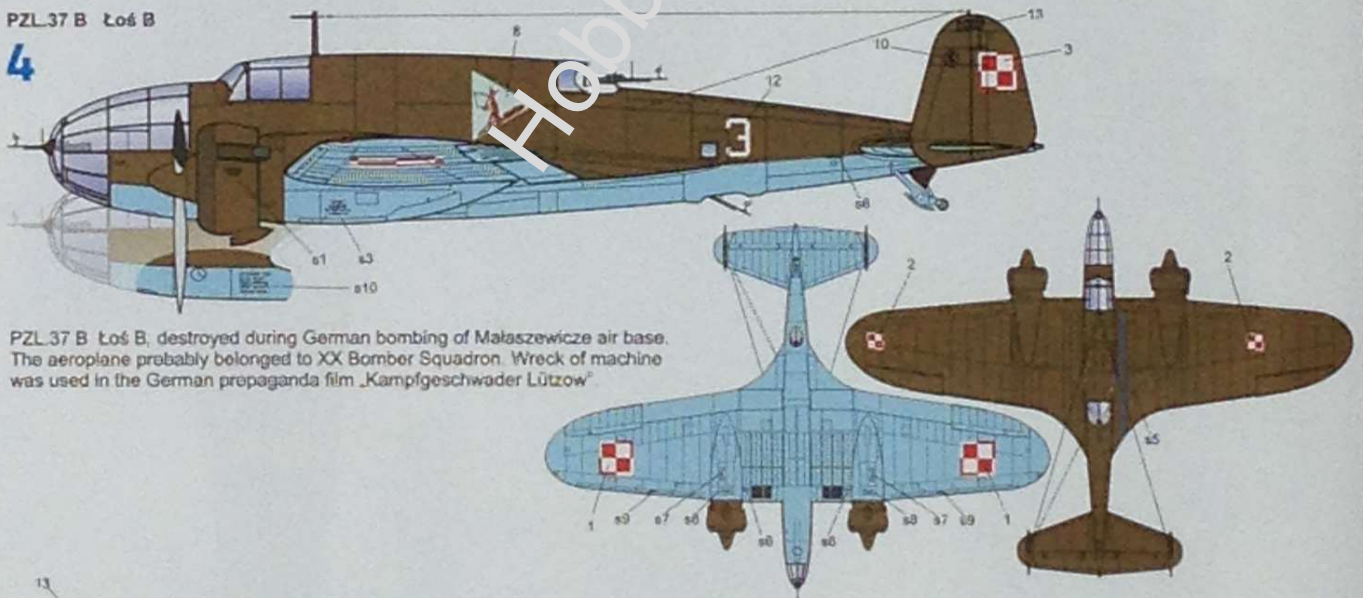

PZL.37 B łoś B, destroyed during German bombing of Małaszewicze air base. The aeroplane probably belonged to XX Bomber Squadron. Wreck of machine was used in the German propaganda film „Kampfgeschwader Lützow“.

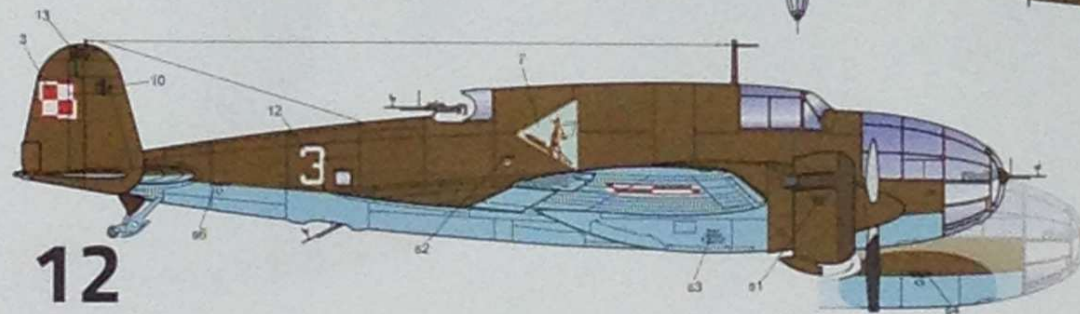

12