

Plastic model kit containing 657 parts.

Wing span: 989 mm Length: 709 mm

1/32
SCALE



0 1 E 0 2 9

B-17 F Flying Fortress

The Boeing B-17 'Flying Fortress' was one of the U.S.A.'s main four-engine heavy bombers, operating alongside the B-24 Liberator, and the later B-29 Superfortress, in all theatres of World War 2. It's a fact that the B-17 almost never saw its place in history and the defeat of Nazi Germany, as the prototype, known as Model 299, crashed due to pilot error during its evaluation in October 1935. Thankfully, the design had shown such promise during the testing phase, in fact exceeding the requirements of the original specification, that further prototypes were ordered despite Boeing losing the original contract with the United States Army Air Corps. It was this further evaluation that saw the type enter active service in 1938. The actual name 'Flying Fortress' was coined by a newspaper hack who witnessed a roll-out of the machine, bristling with guns and turrets, and Boeing realised that this was the sort of propaganda they needed, and trademarked the name. After the initial prototypes, serial production of the B-17 began with the B-17B variant, and underwent a major revision with the introduction of the 'E'. This type featured a substantially redesigned tail and fillet that featured throughout subsequent versions, giving the B-17 its iconic profile. An extra 10ft of length was added to the fuselage. Other refinements included the addition of a tail and dorsal turret, and

the addition of a Bendix turret to replace the fixed bathtub type that had graced previous versions. This was found to be disappointing, and was eventually replaced with the Sperry ball turret that became a permanent feature of all future marques.

Differences between the E & F versions were mostly changes in nose armament layout, with staggered cheek guns being implemented, and a change in the bombardier's glass nose, although this would vary occasionally between machines, with a number of sub-types and adaptations being fitted. Other changes included engine cowls with rounder forward radius, paddle-blade prop blades and strengthened undercarriage that allowed the internal bomb load to double from 4000lb to 8000lb.

The B-17 F was powered by 4 x Wright R-1820 "Cyclone" turbocharged radial engines that were constantly updated over the service life of the B-17, and also carried 11 x .50cal M2 Browning machine guns, with a twelfth being sometimes fitted in the glass nose. Wingspan was 103ft 9in, with a length of 74ft 4in. A crew of 10 was typically carried by the B-17.



BE CAREFUL



REMOVE



GLUE TOGETHER



PLEASE WAIT FOR A FEW MINUTES UNTIL DRY



MAKE 2 PIECES



DRILL HOLE



DO NOT GLUE



INSTANT GLUE FOR METAL



BEND



FILL HOLE



SEQUENCE OF WORK



OPTIONAL



USED COLOUR



APPLY DECAL



MARKING OPTION

CAUTION
When using both glue and paint, do not use these near an open flame, due to the flammable properties of these items.
The symbols provided, such as 'X', refer to the basic colours of parts, although a more comprehensive list is supplied for your use for Tamiya, Mr Hobby and AK-Interactive codes.
When removing parts from sprues, take extreme care. Consider correct tools such as Xuron Sprue Cutters
Please check the symbology on the left and familiarise yourself before building this model kit.

In cooperation with:



www.ak-interactive.com



HK MODELS 01E029

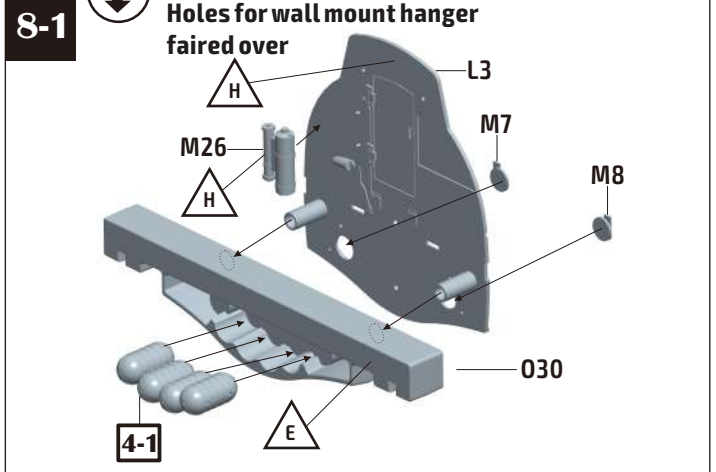
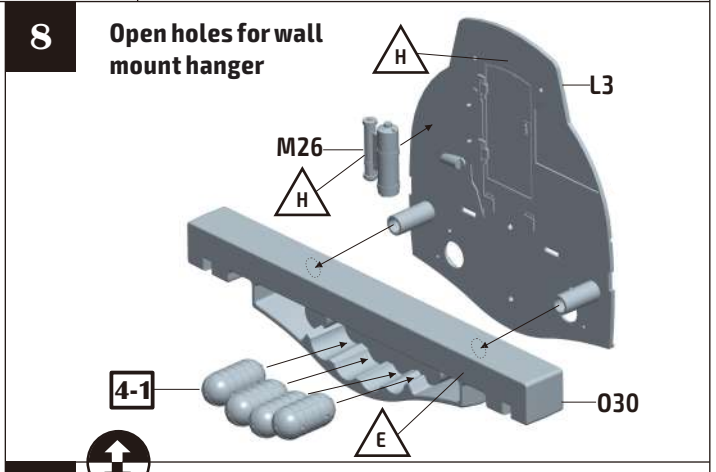
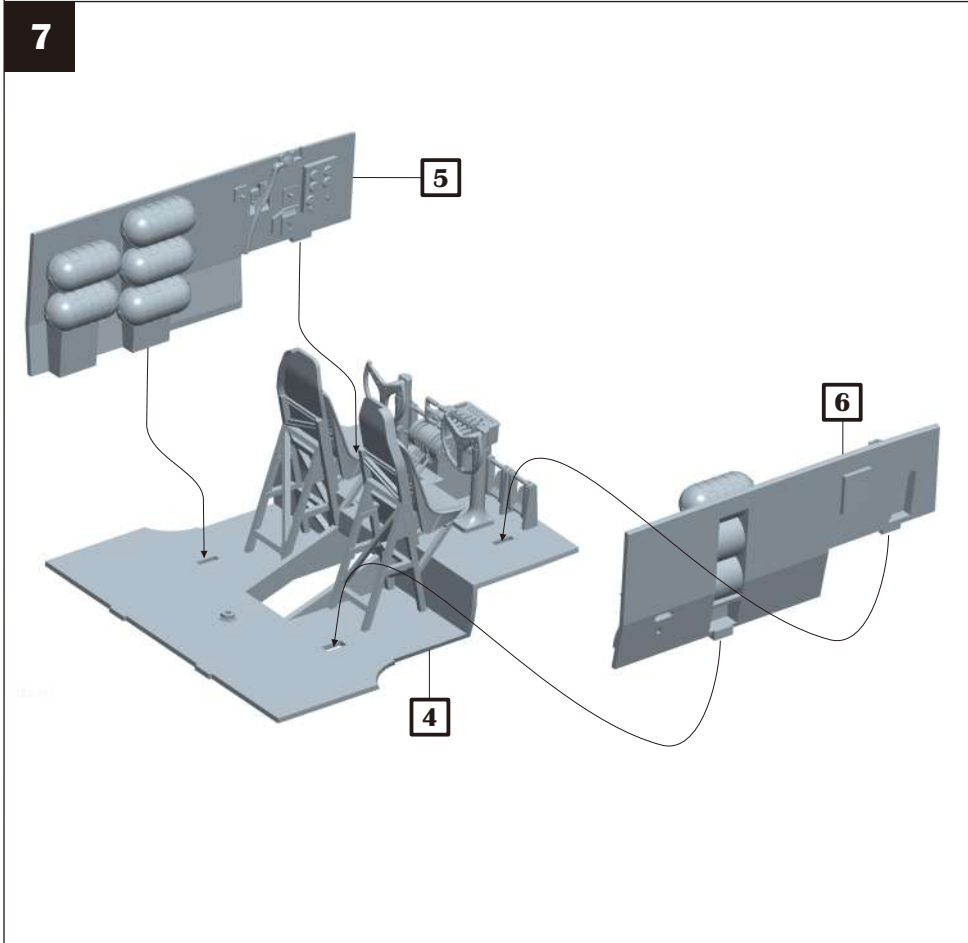
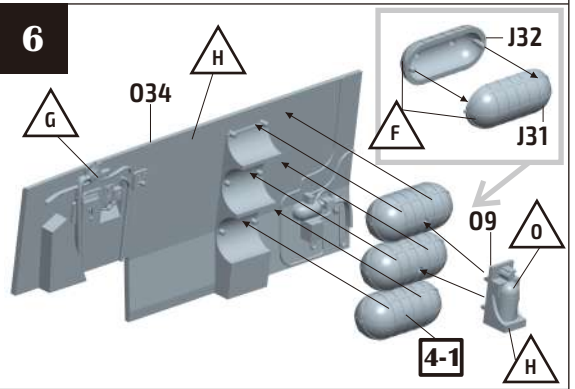
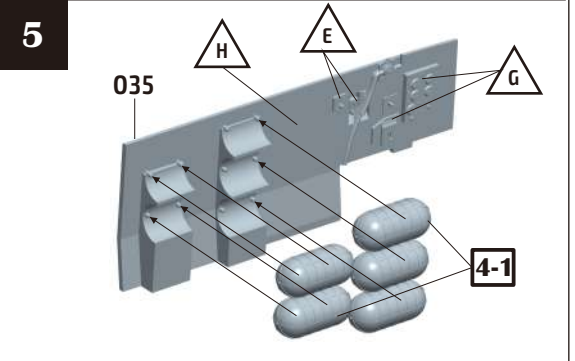
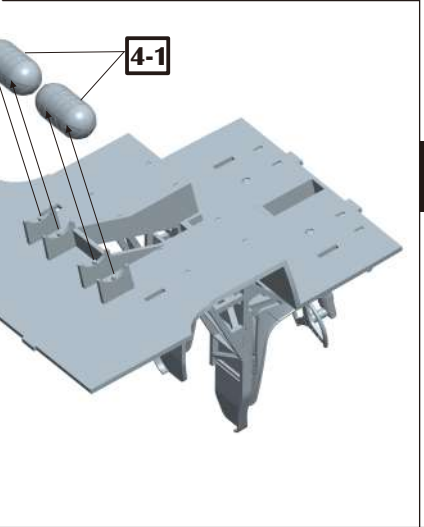
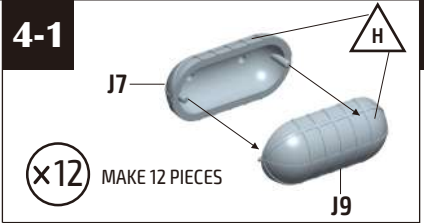
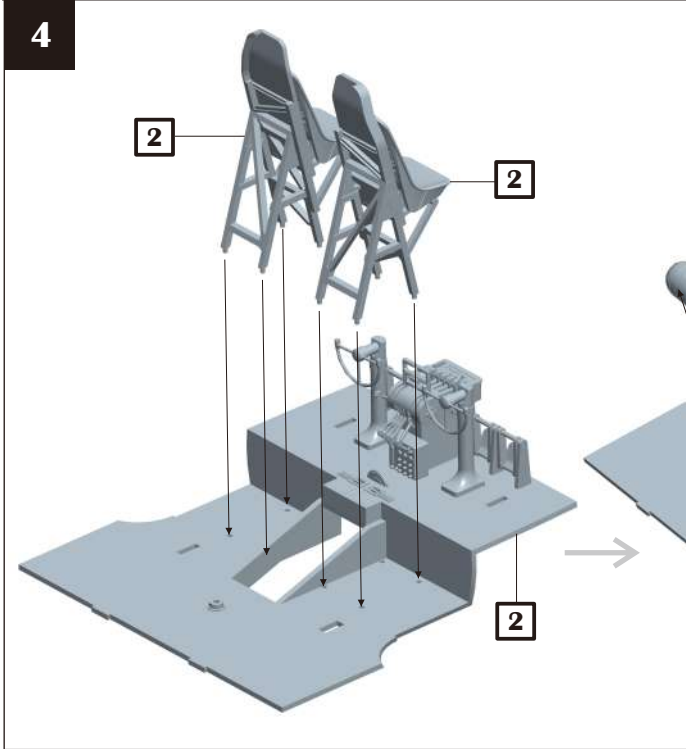
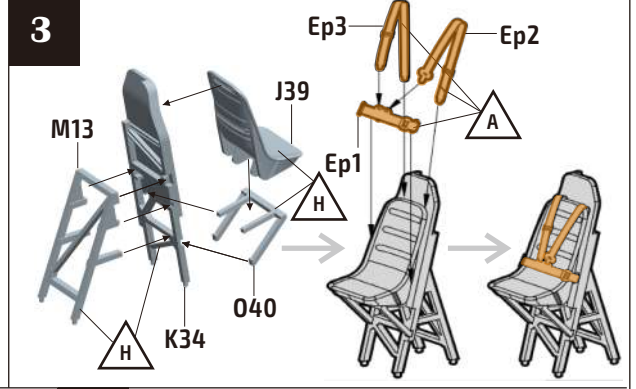
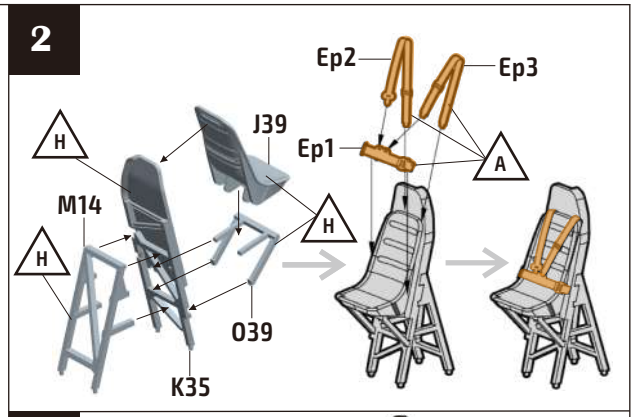
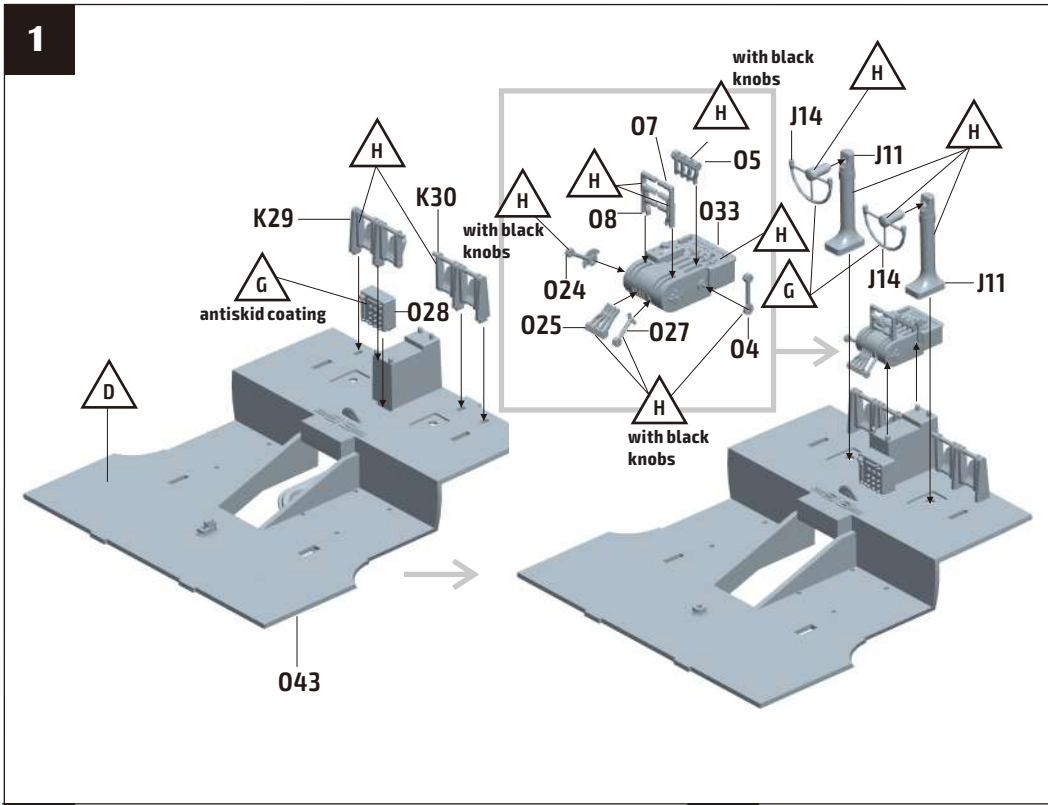

9

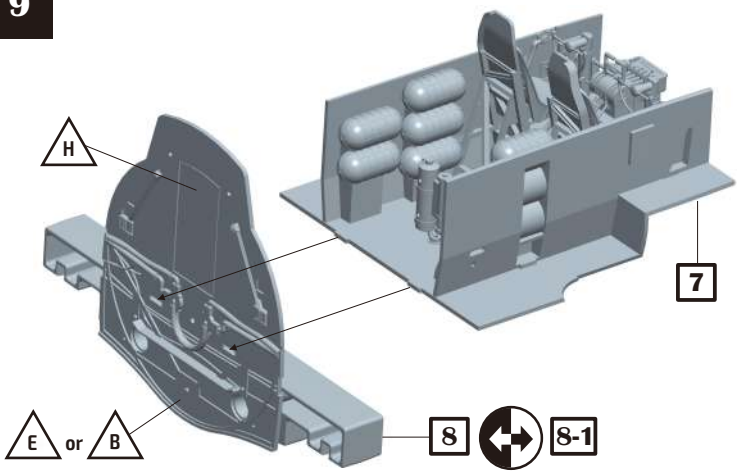

10

×10 MAKE 10 PIECES

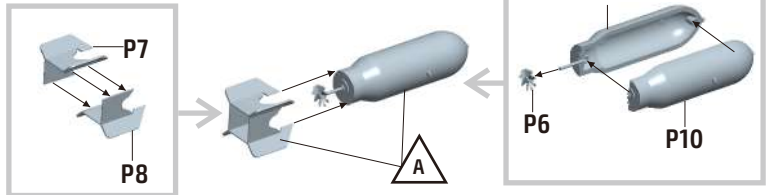

11

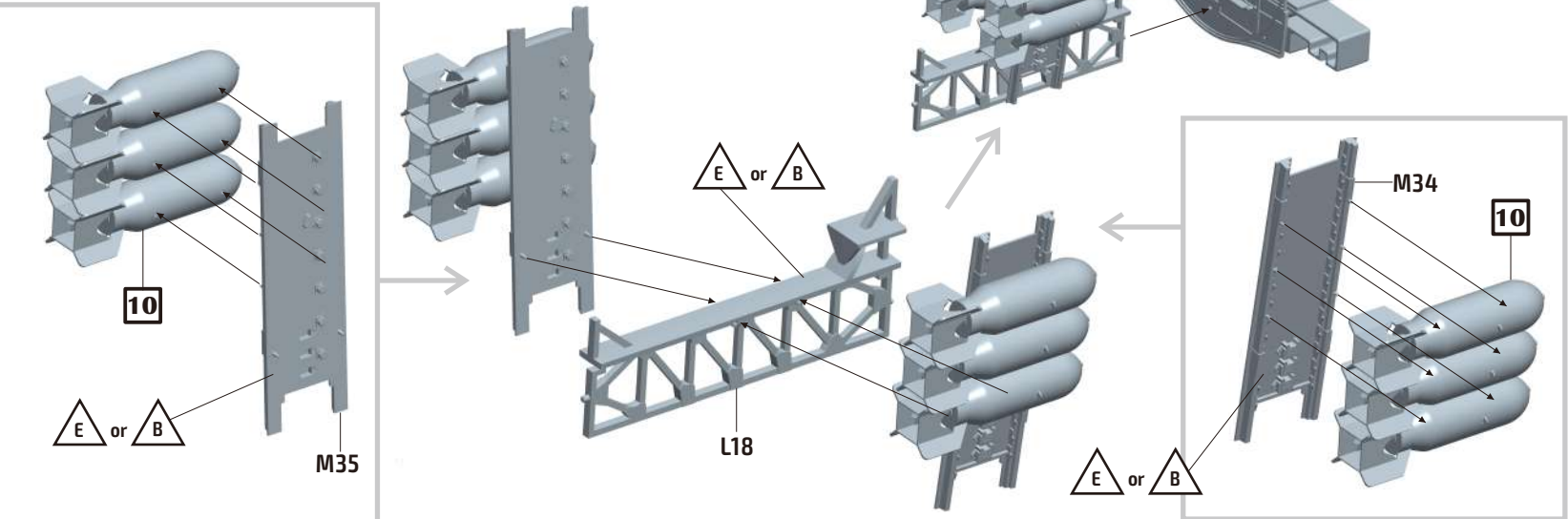
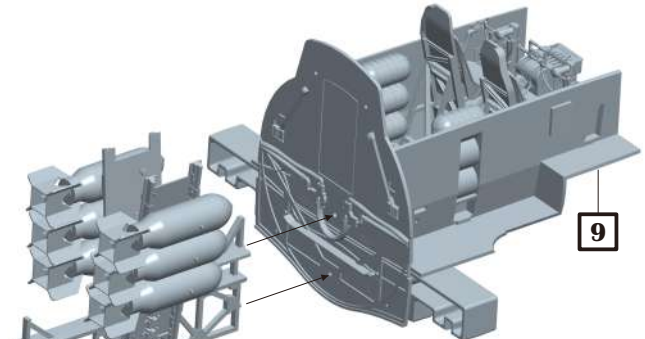

12

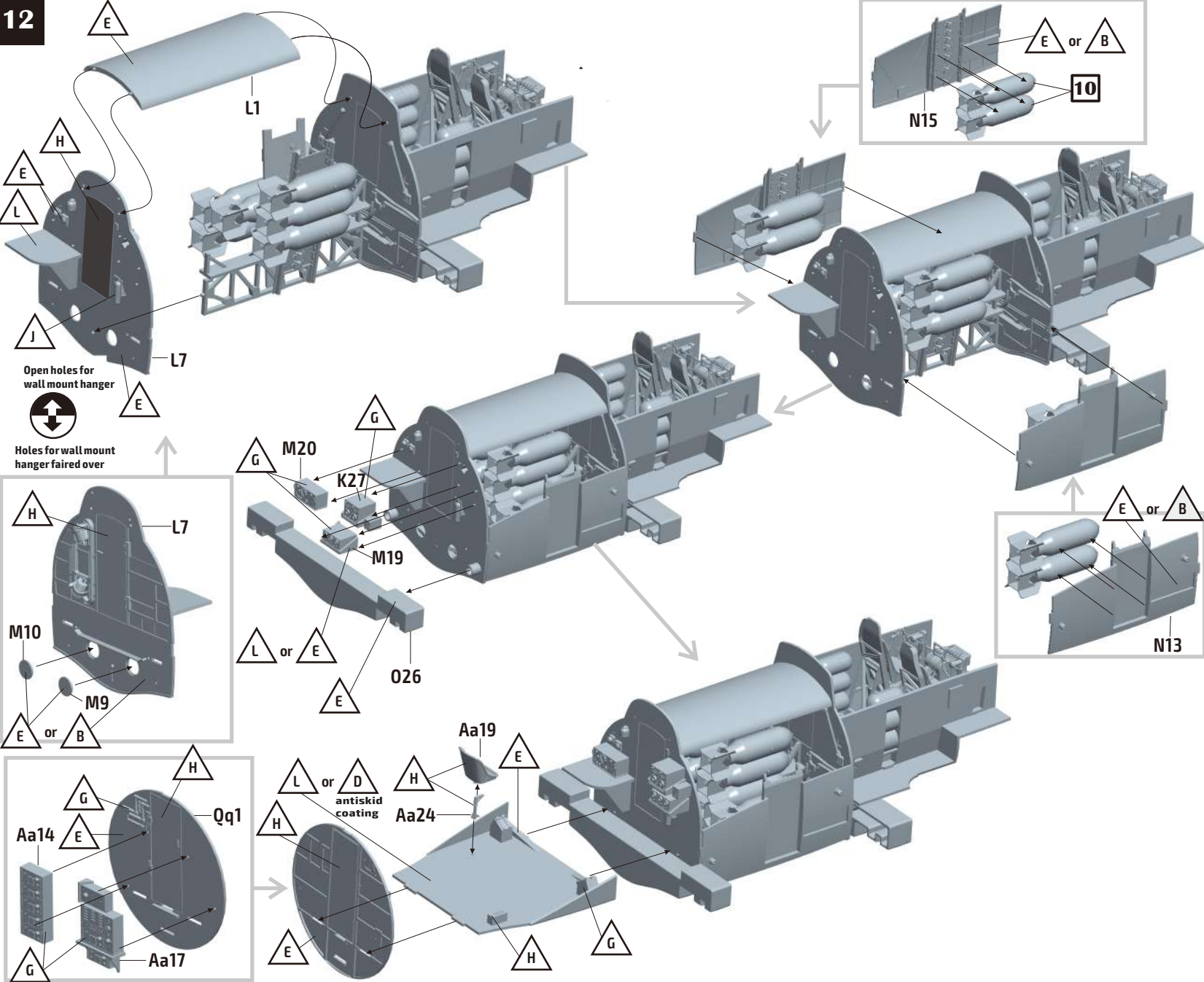

13

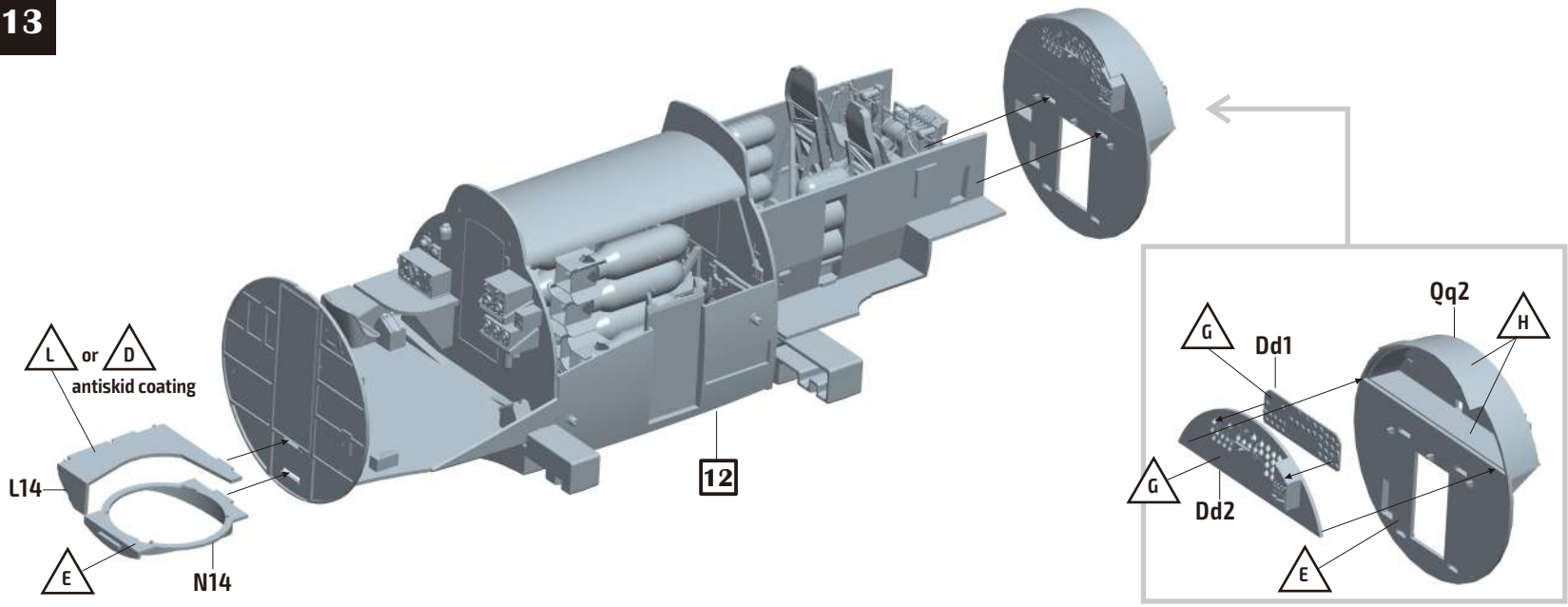

14

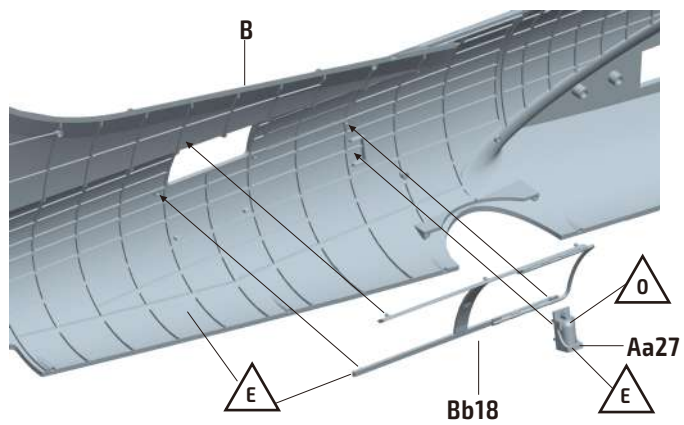

15

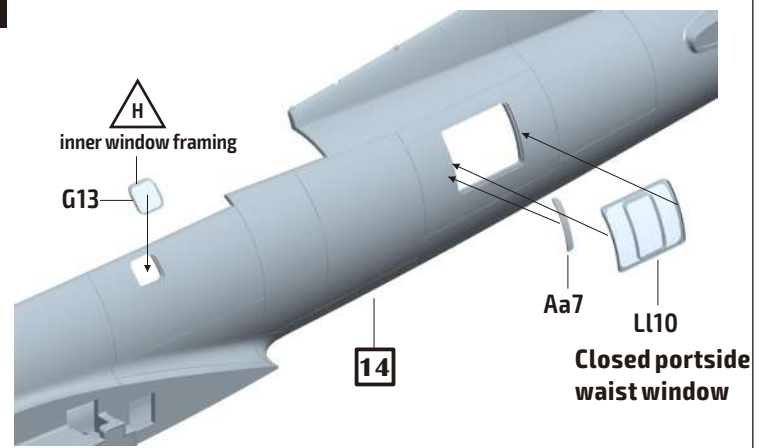

16

Portside waist gun in firing position (use in conjunction with open waist window)

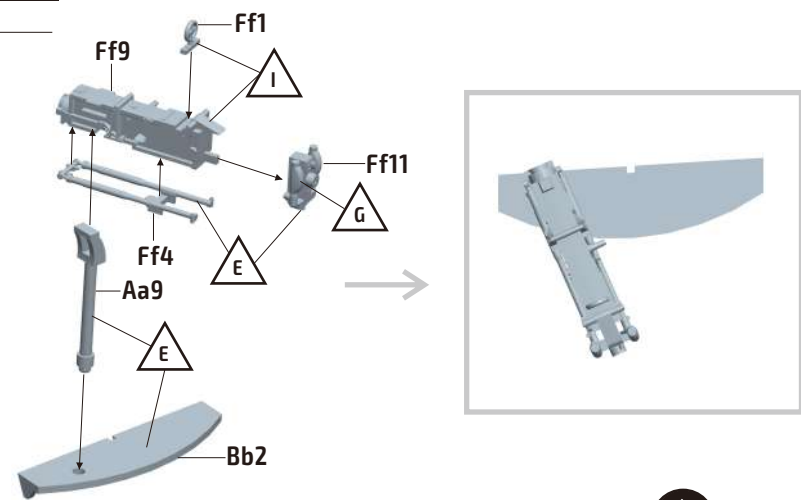

15-1



Open portside waist window

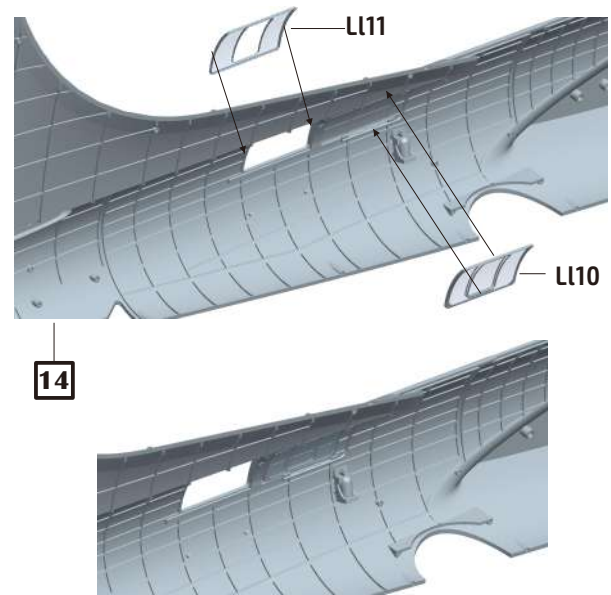

16-1

Portside waist gun in stowed position (use in conjunction with closed waist window)

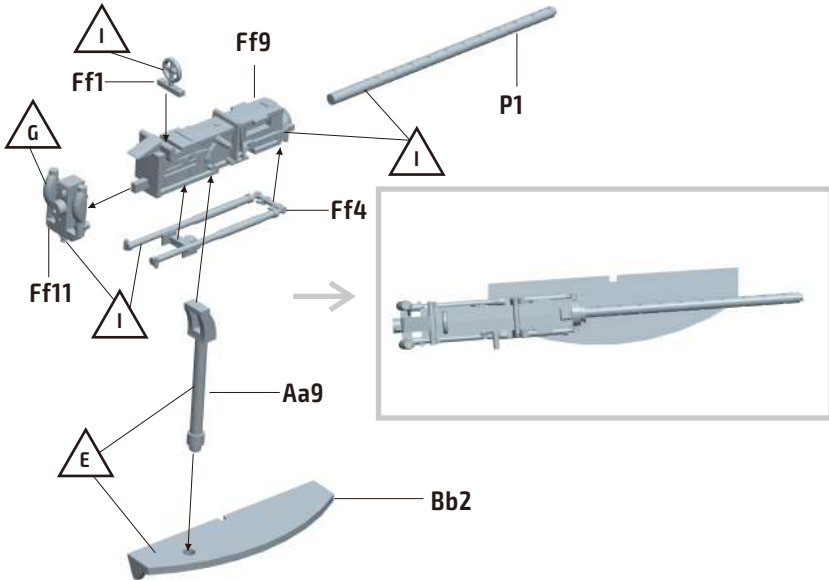

17

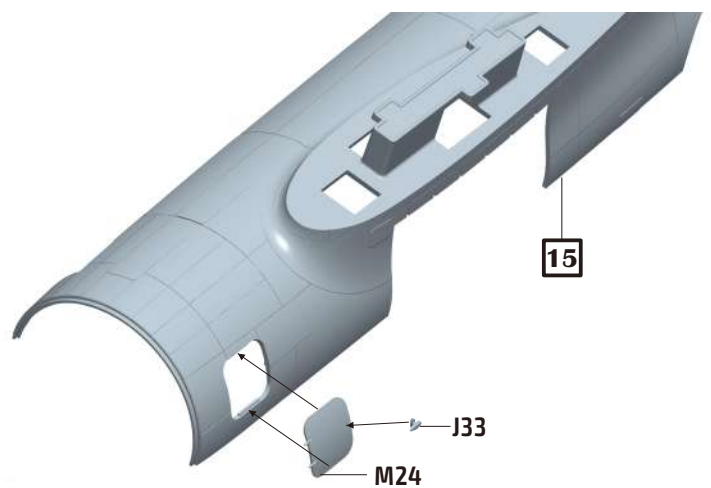

18

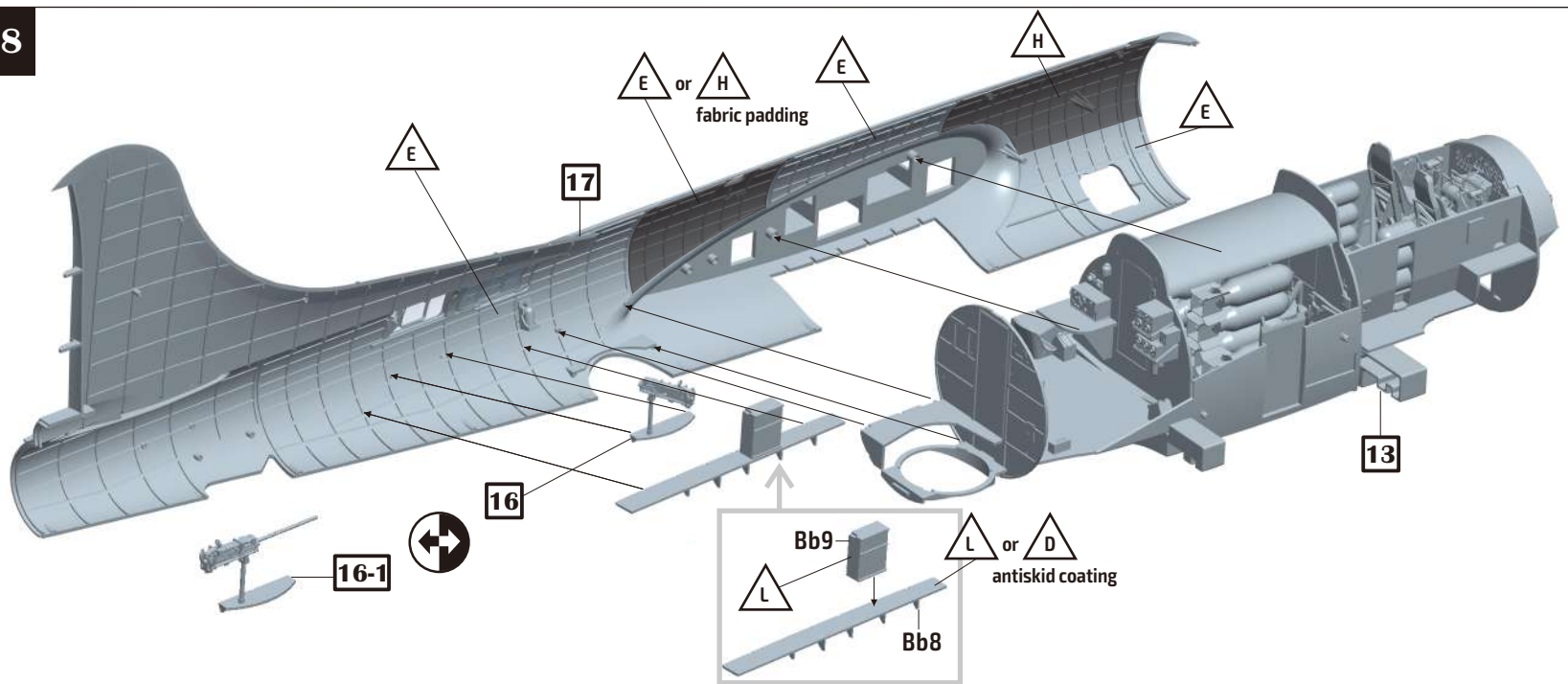

19

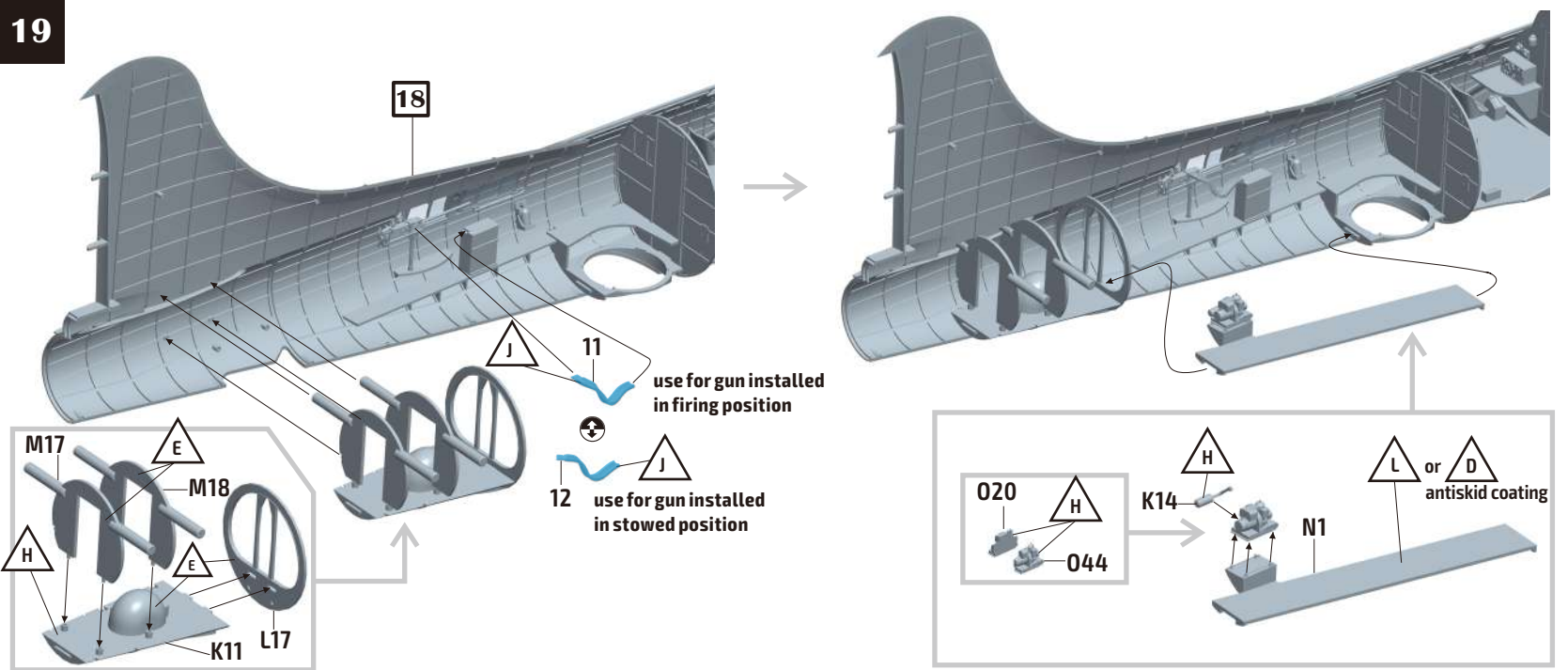

20-1

Portside waist gun in firing position (use in conjunction with open waist window)

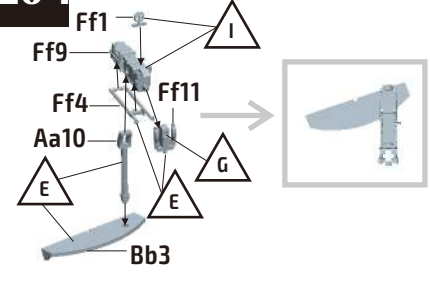

20

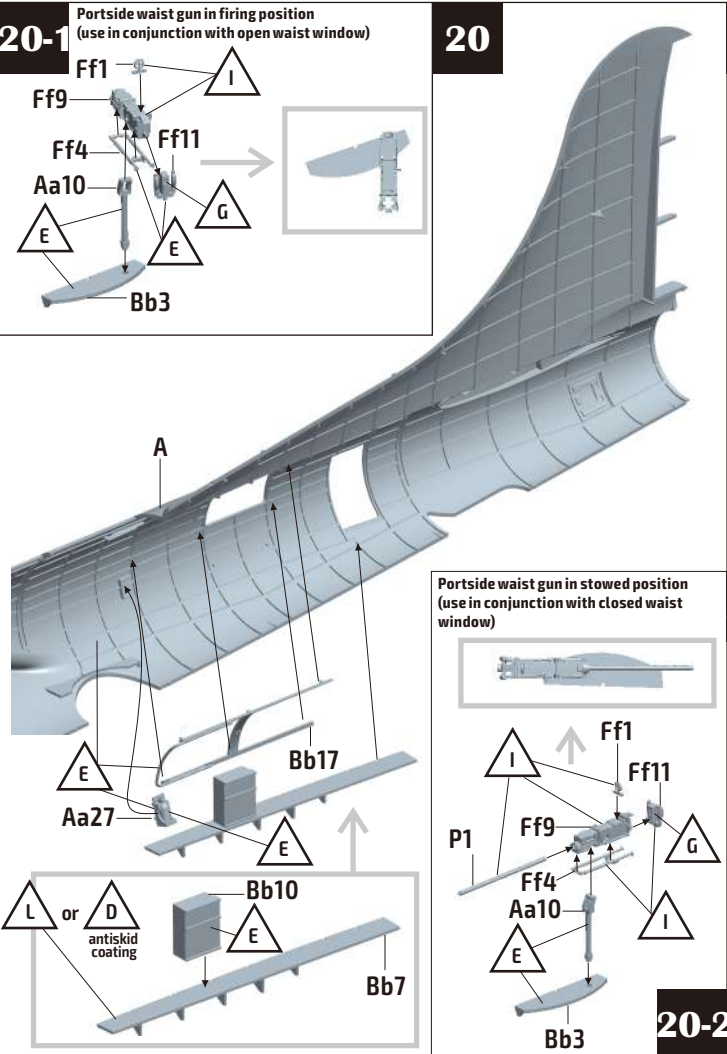

Portside waist gun in stowed position (use in conjunction with closed waist window)

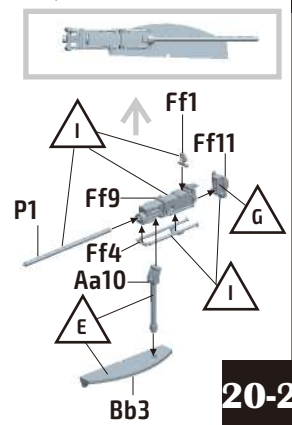

21

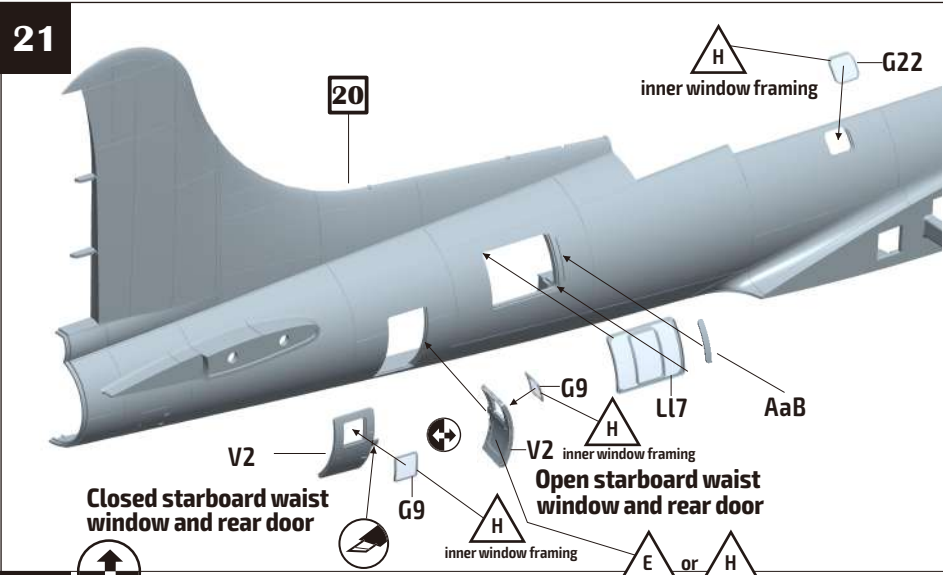

21-1

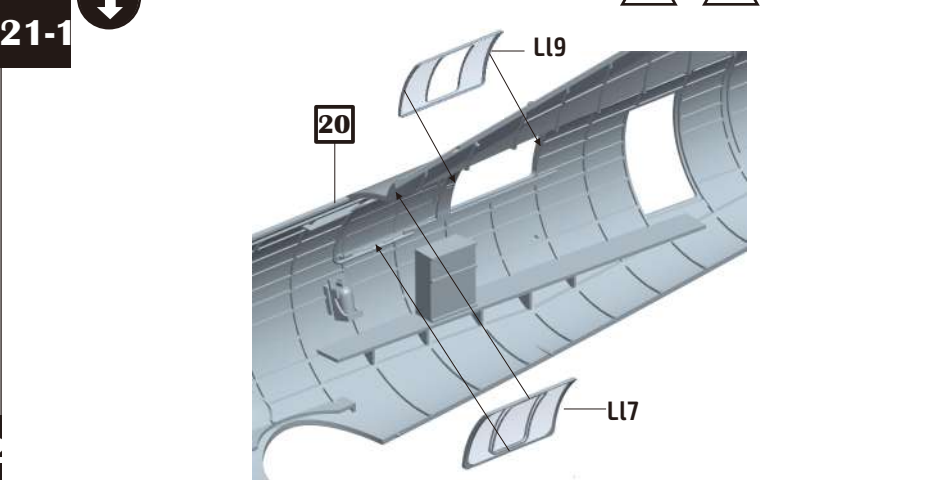

22

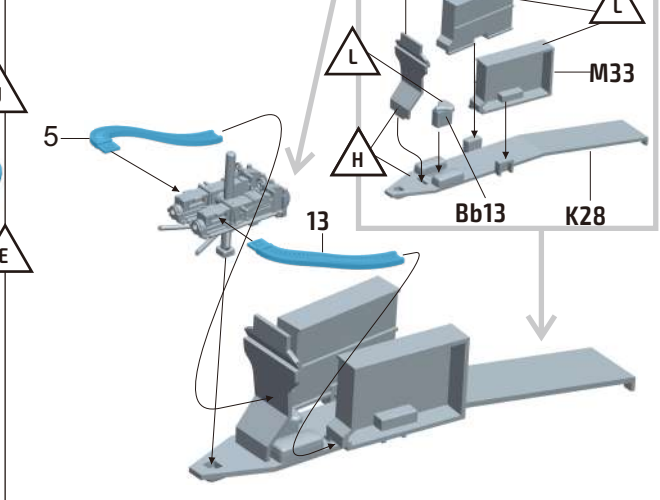
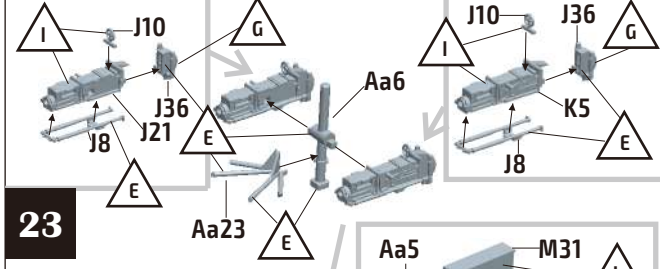
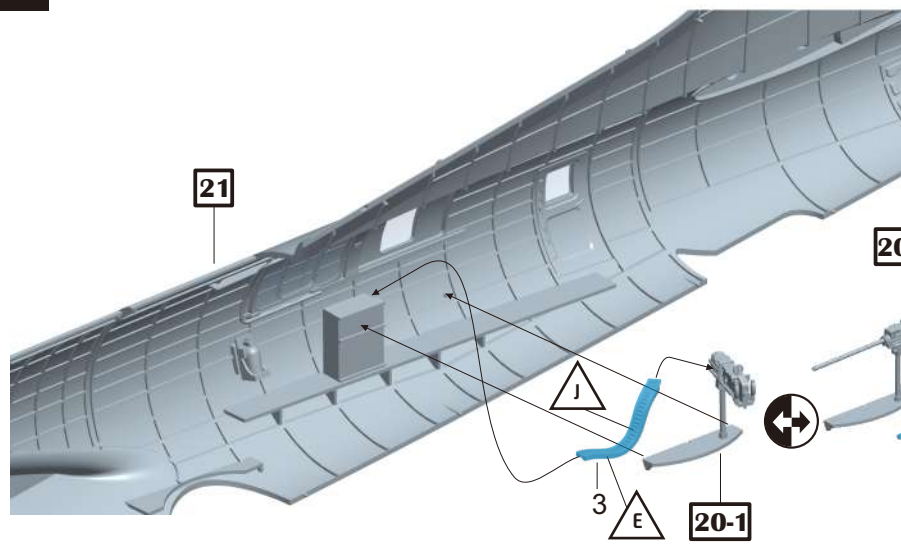

24

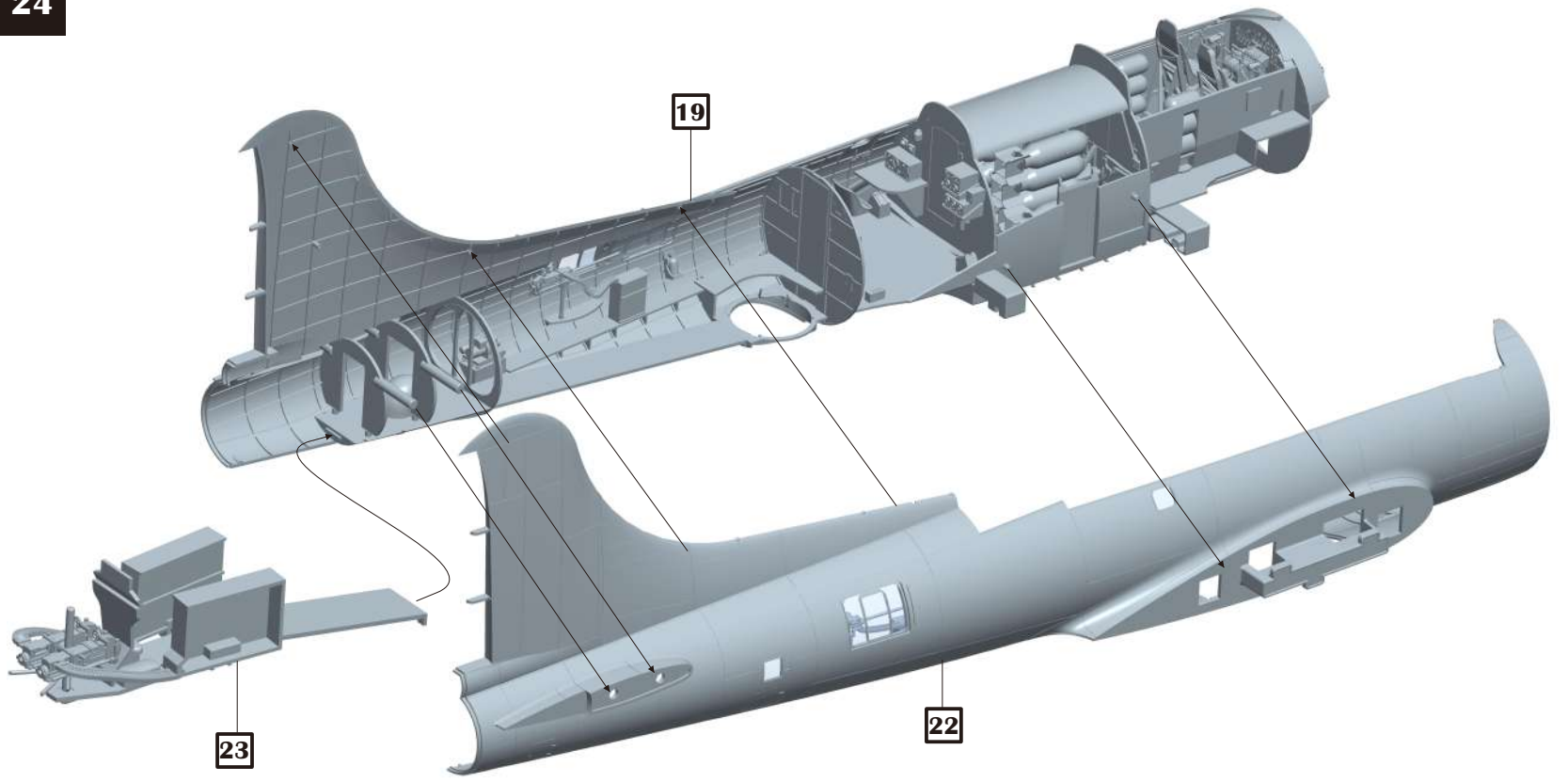

25

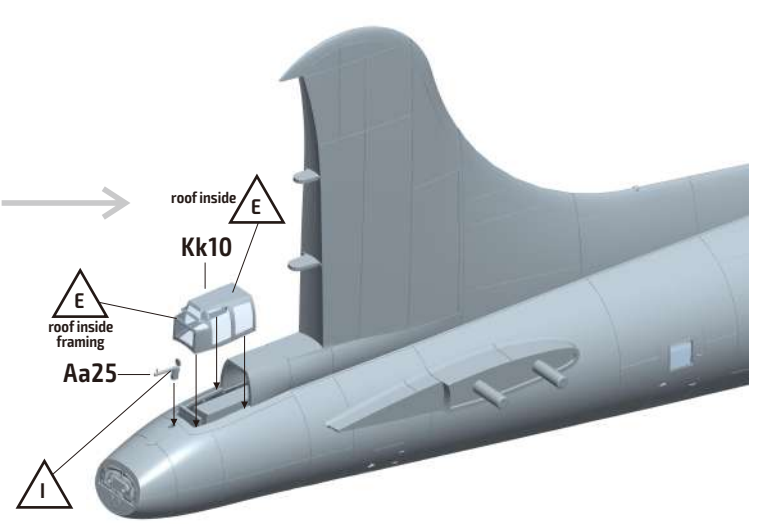
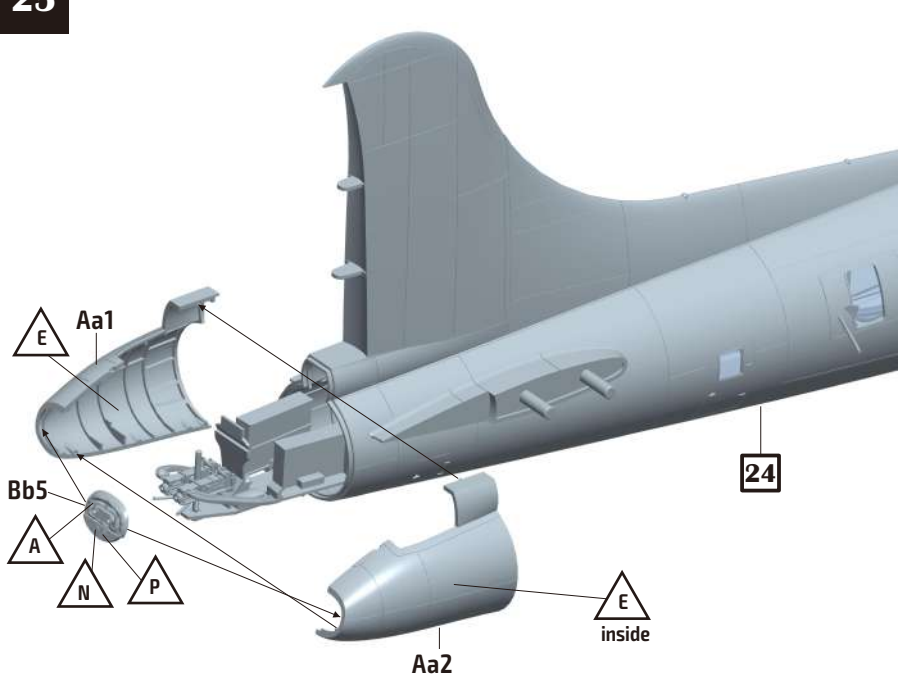

26

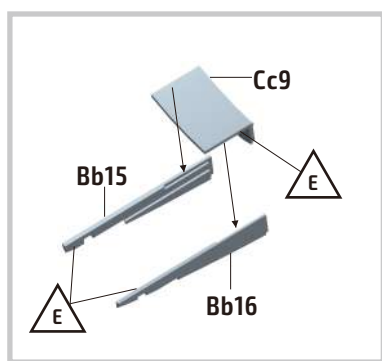

Radio operator's gun in firing position

Radio operator's gun in stowed position

26-1

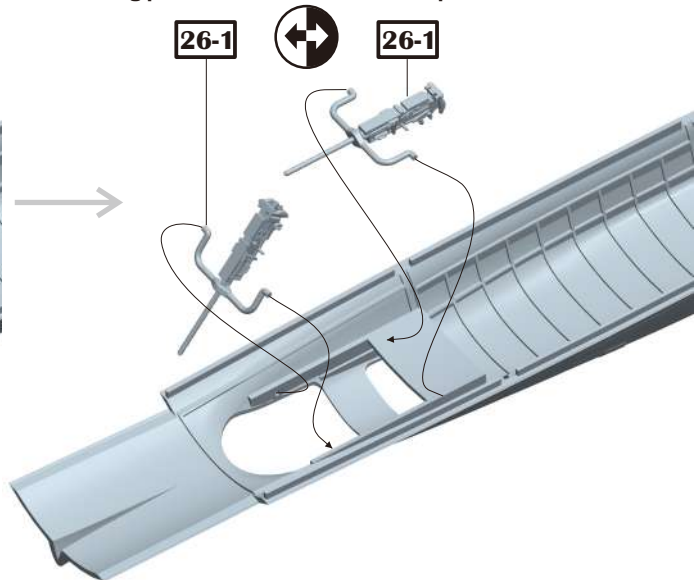
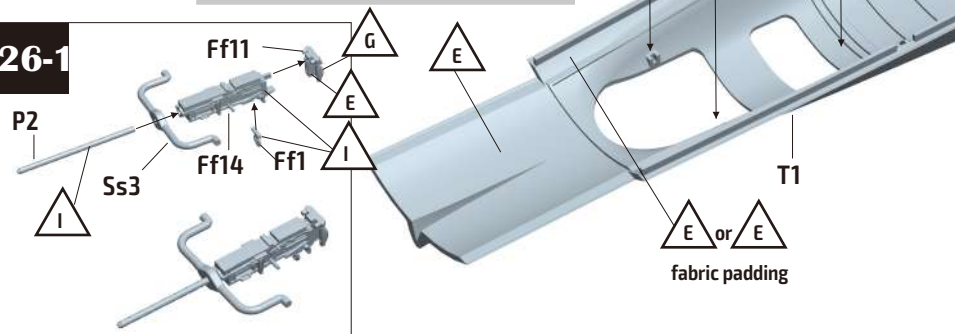

27

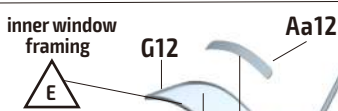
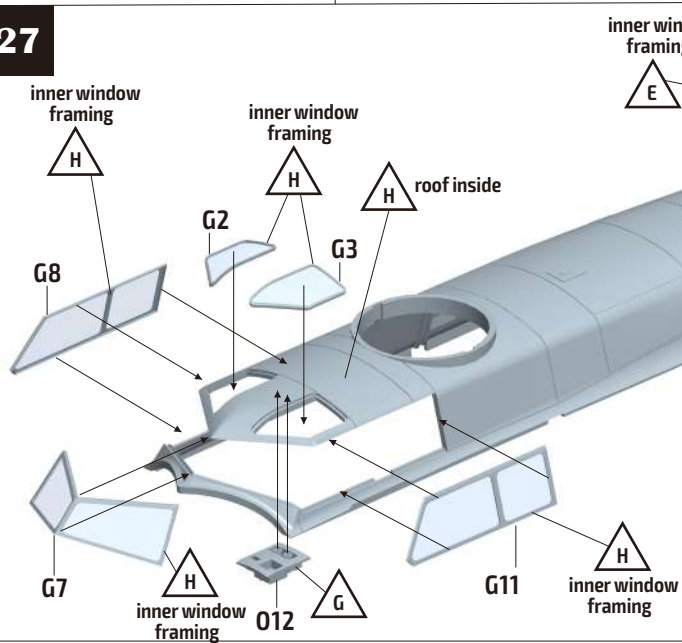

Closed radio operator's gun position window

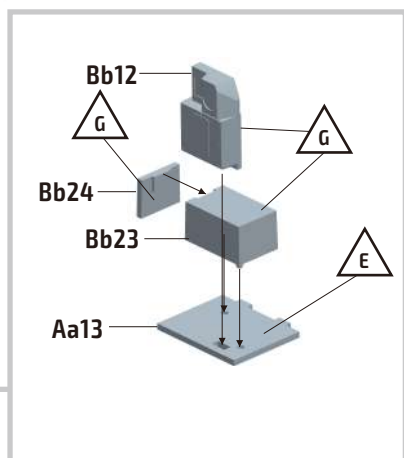
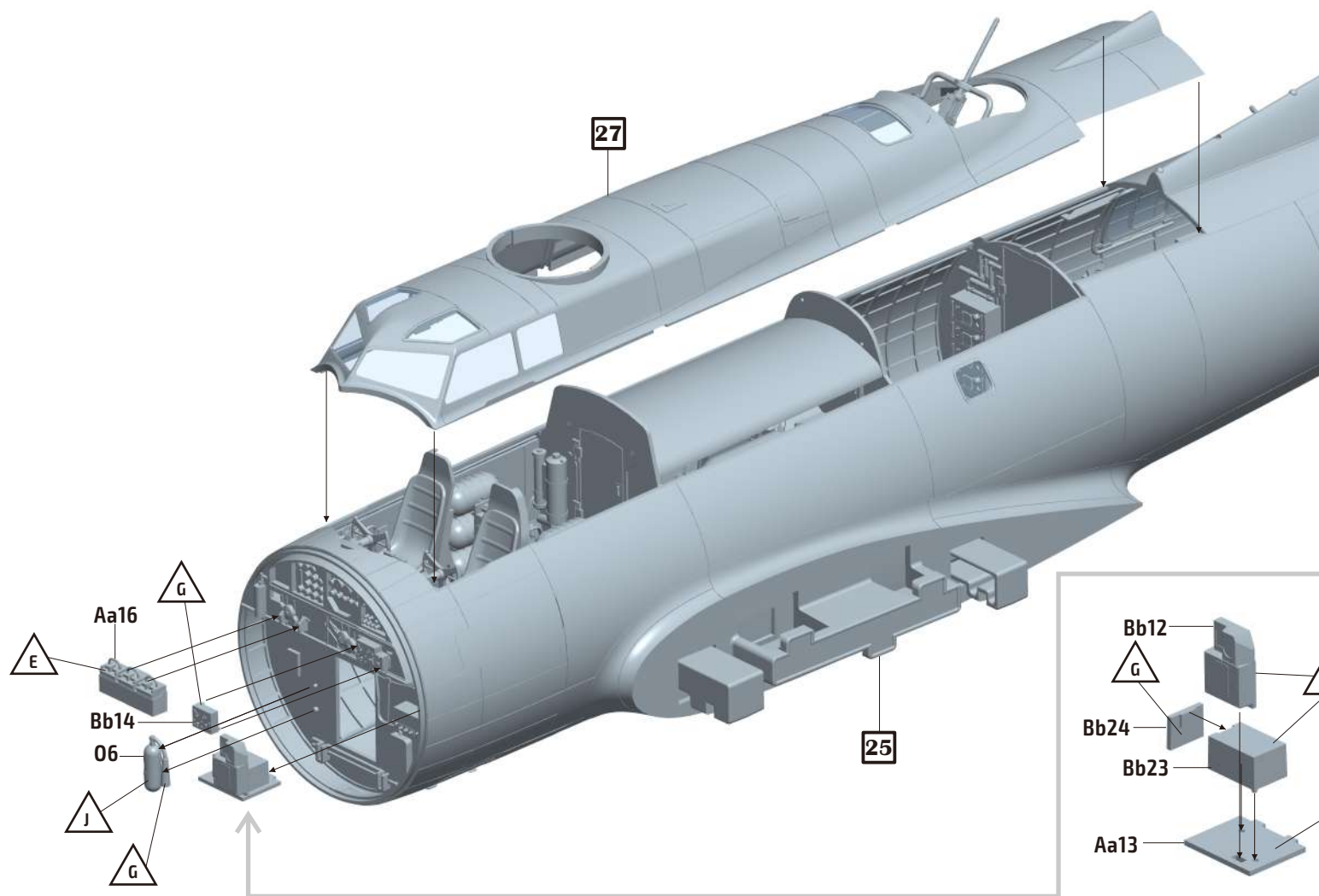
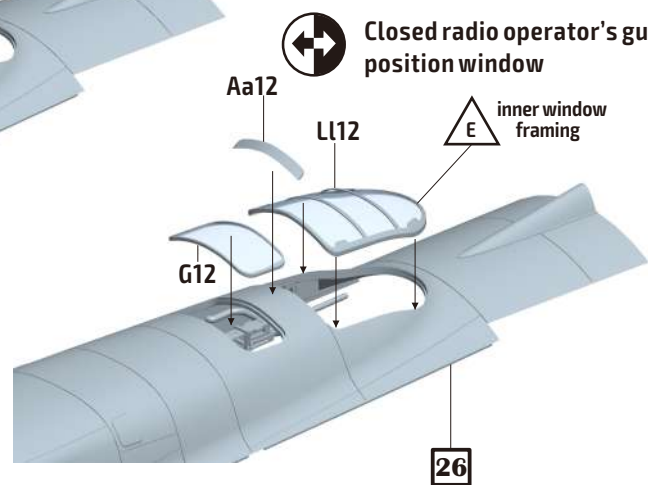

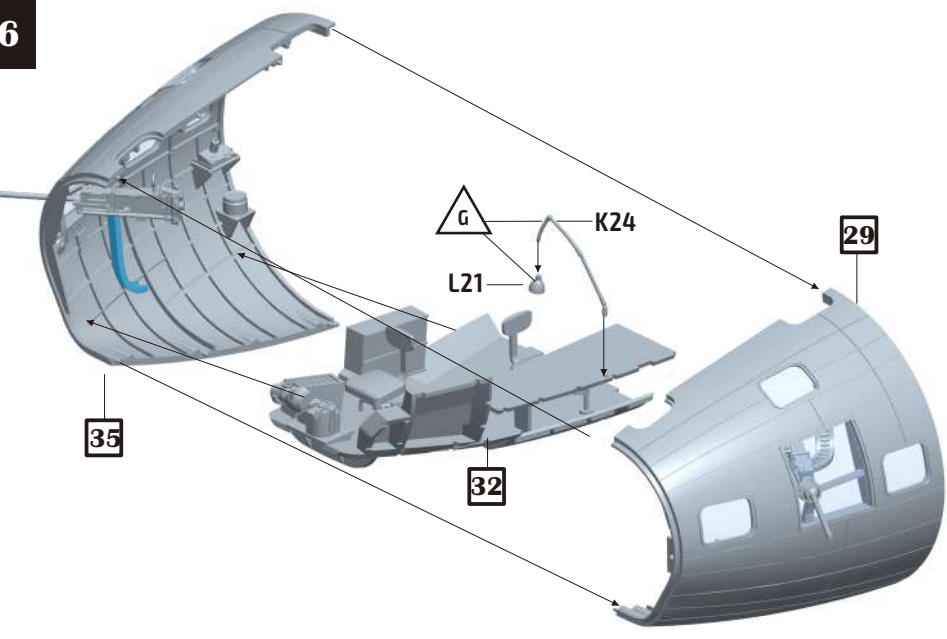
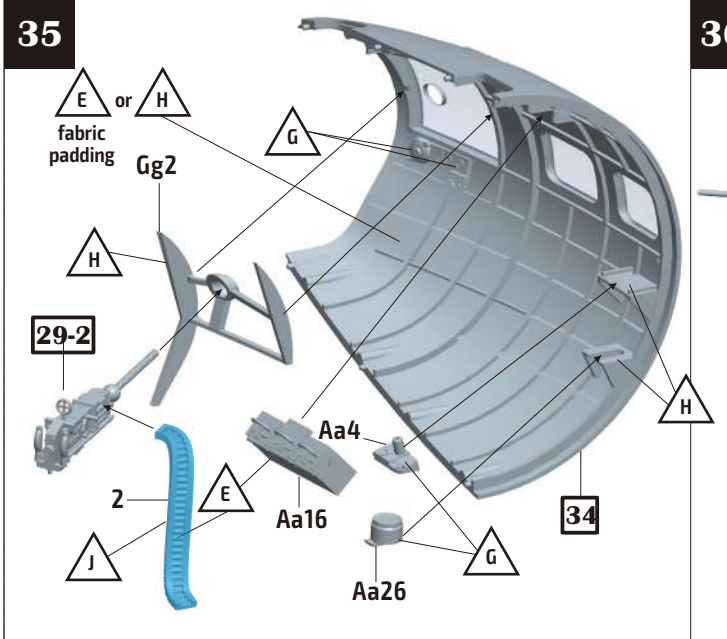
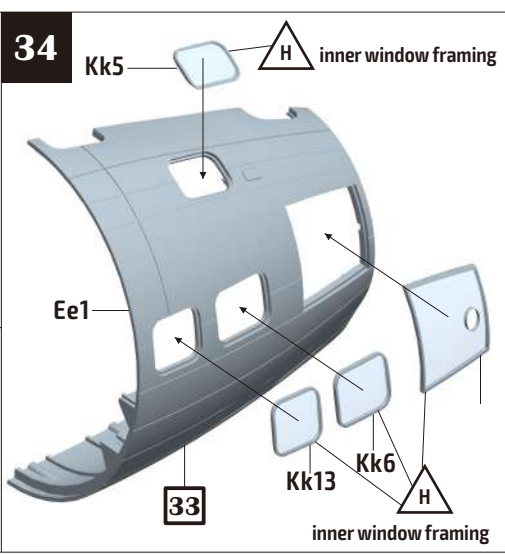
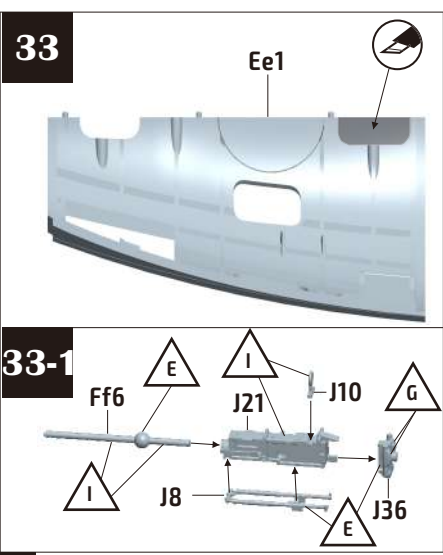
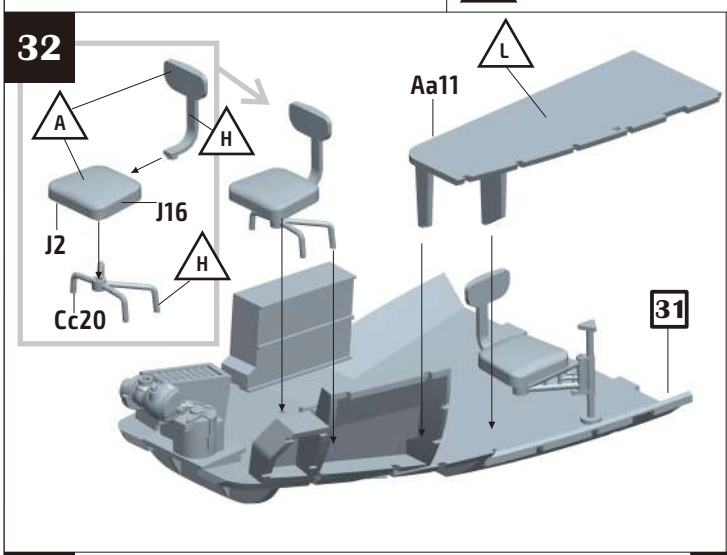
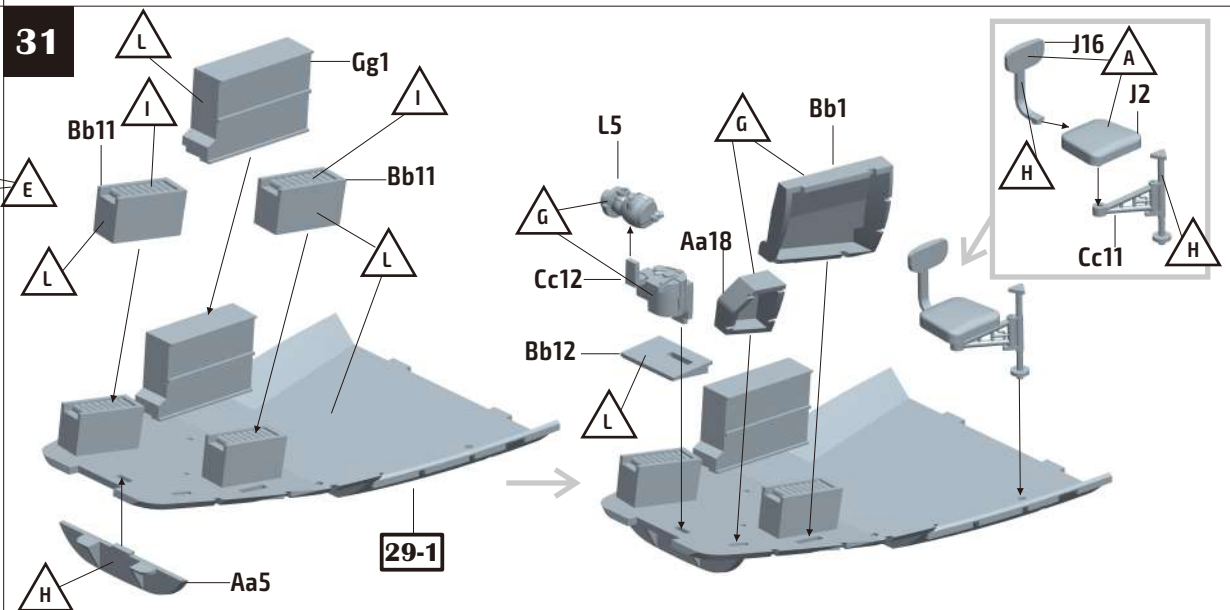
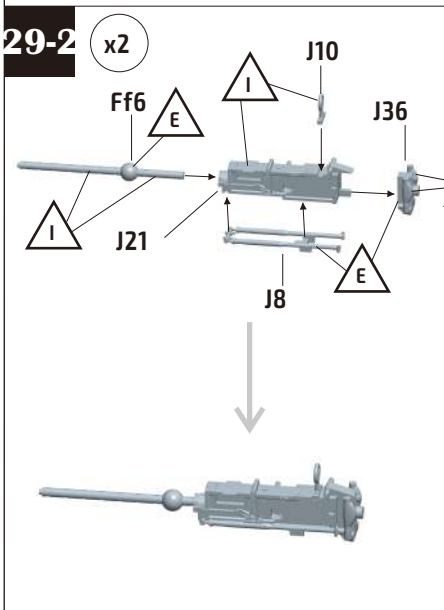
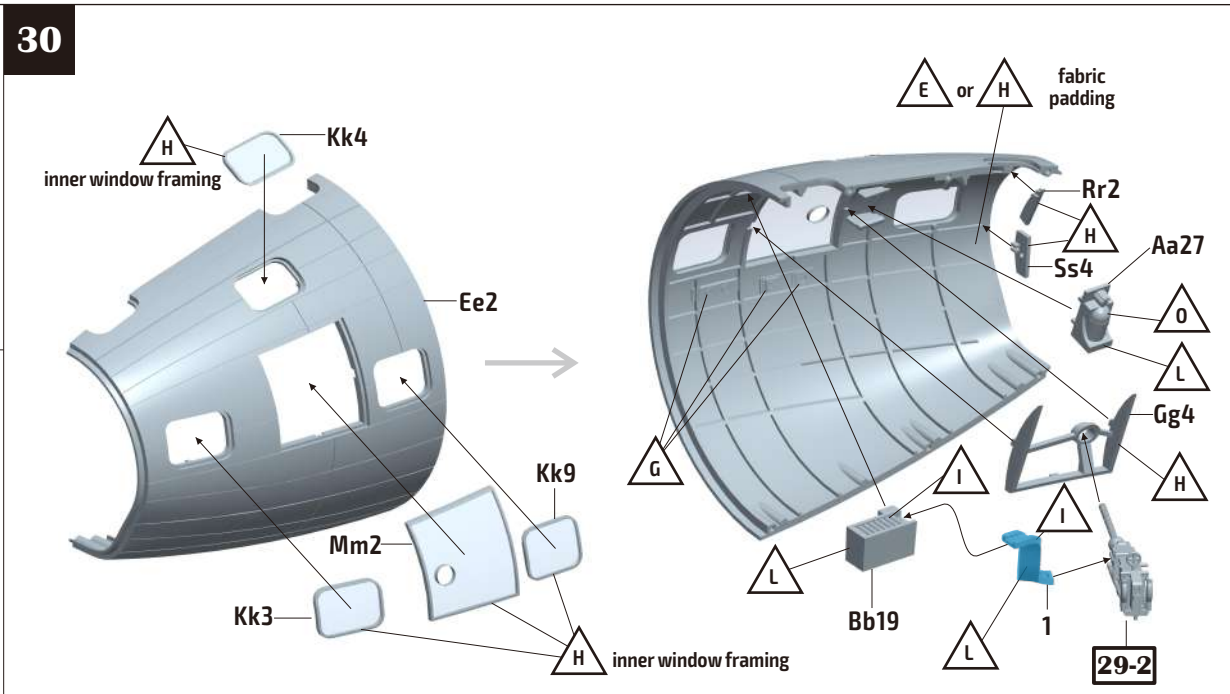
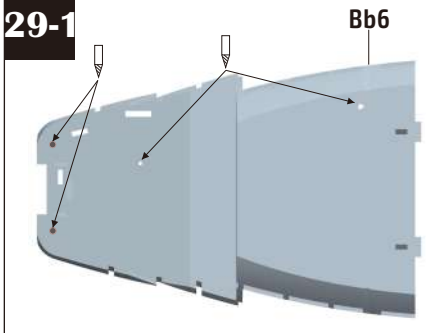
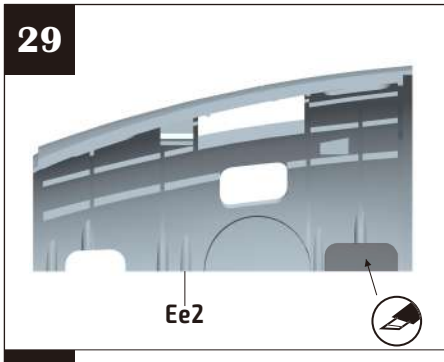

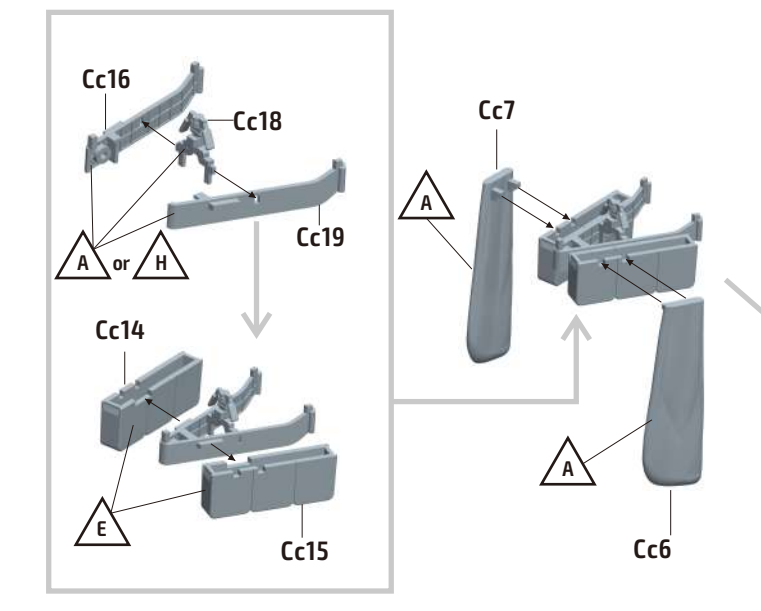
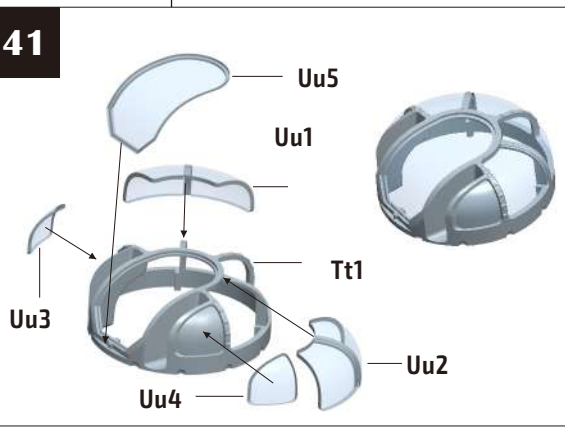
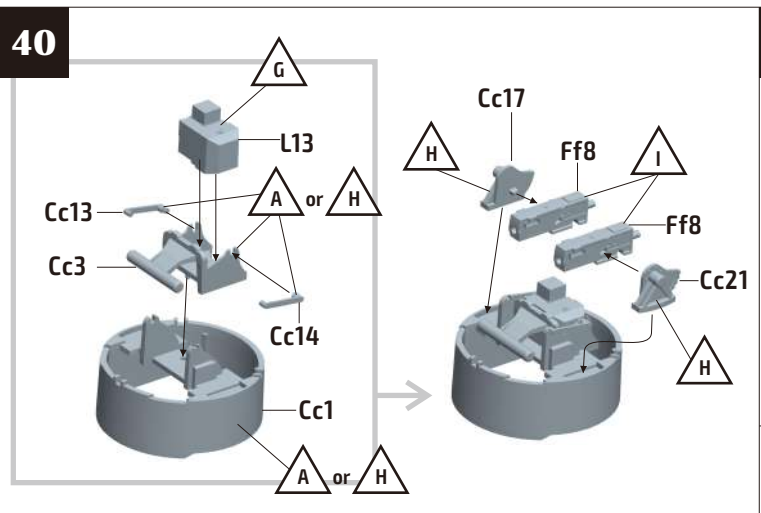
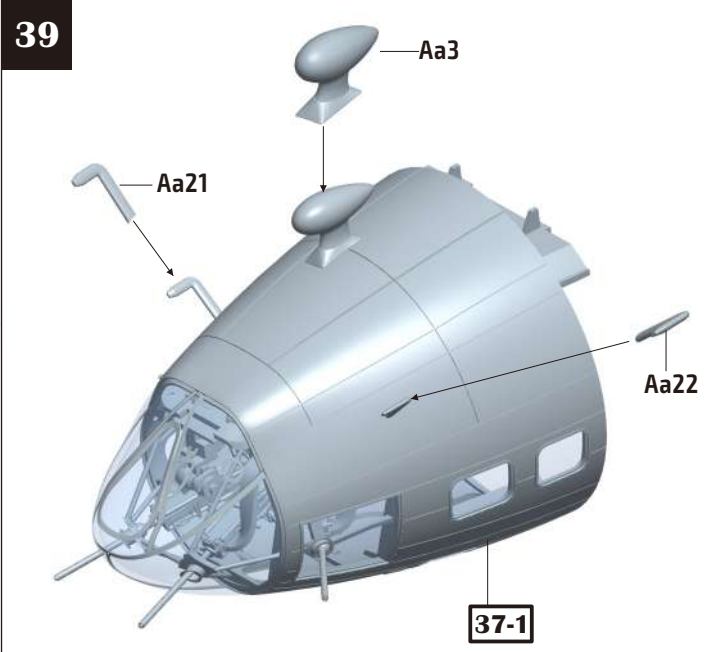
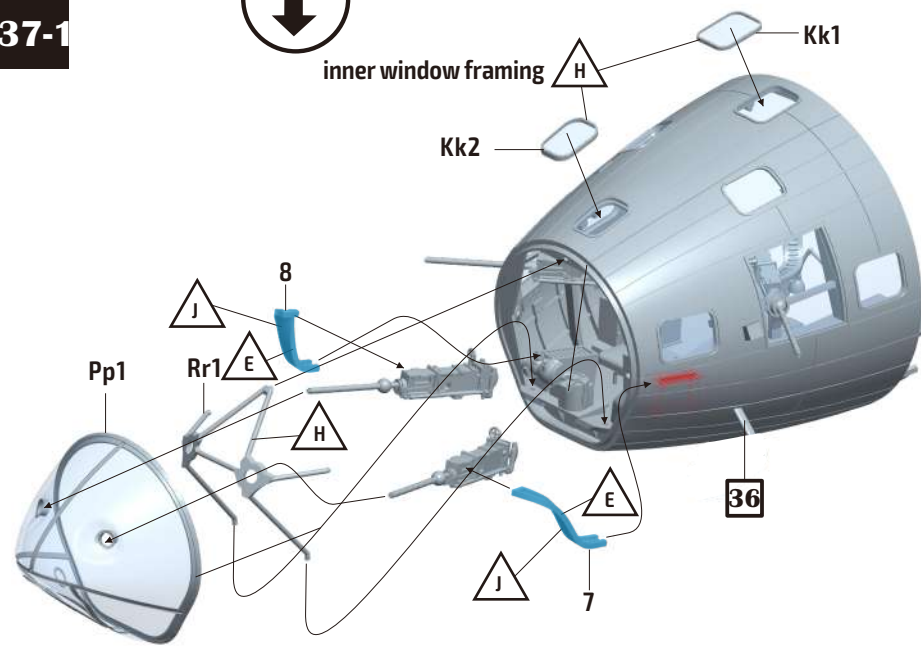
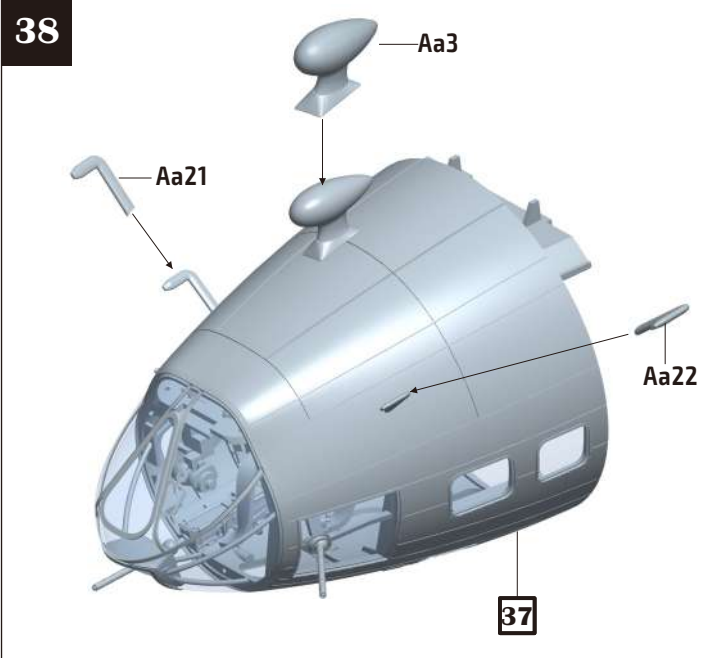
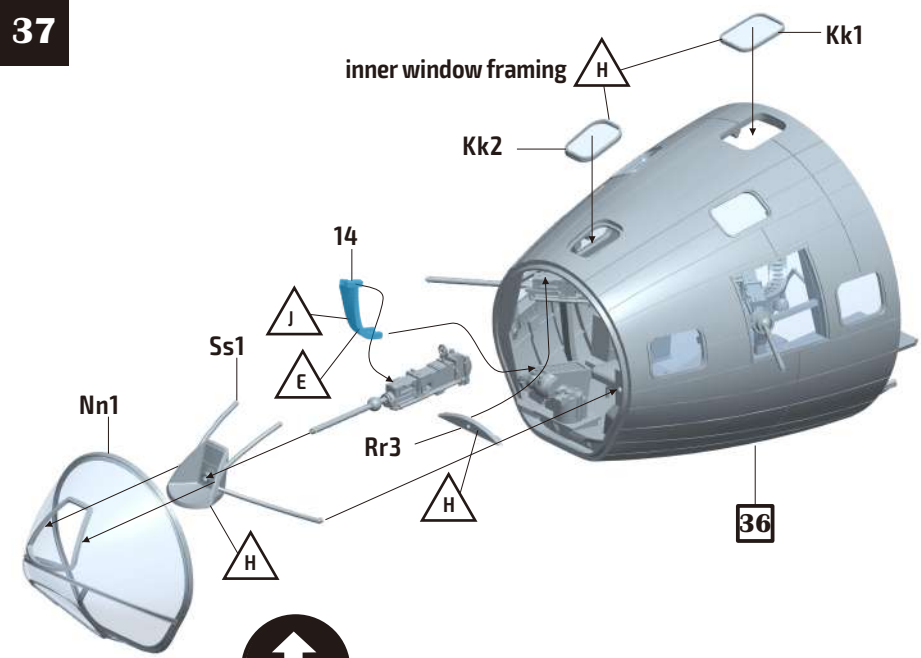

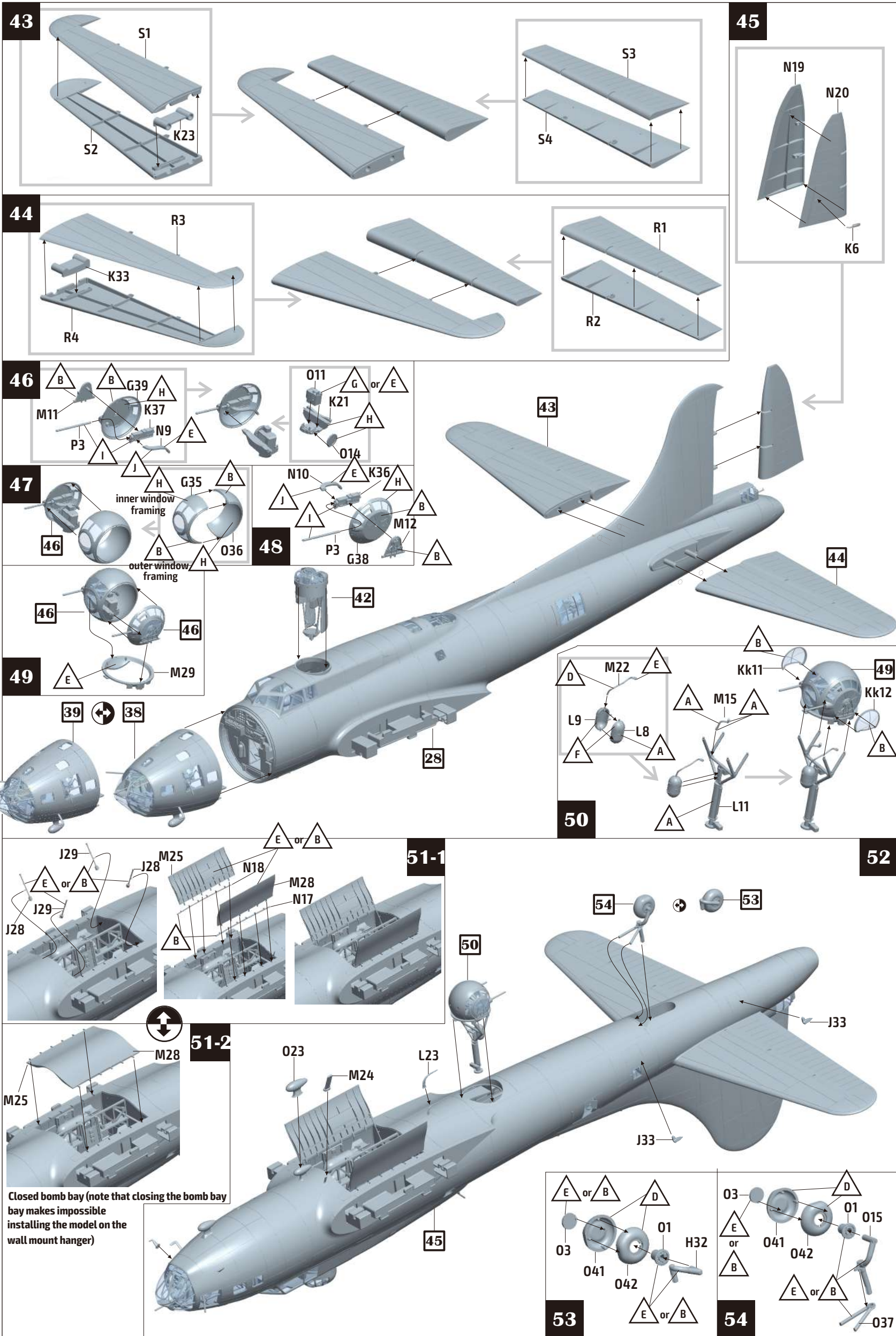

55-1

Main landing gear in retracted position

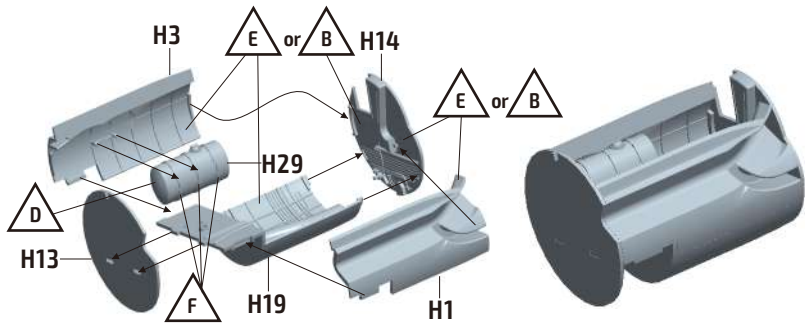

55-2

Main landing gear in extended position

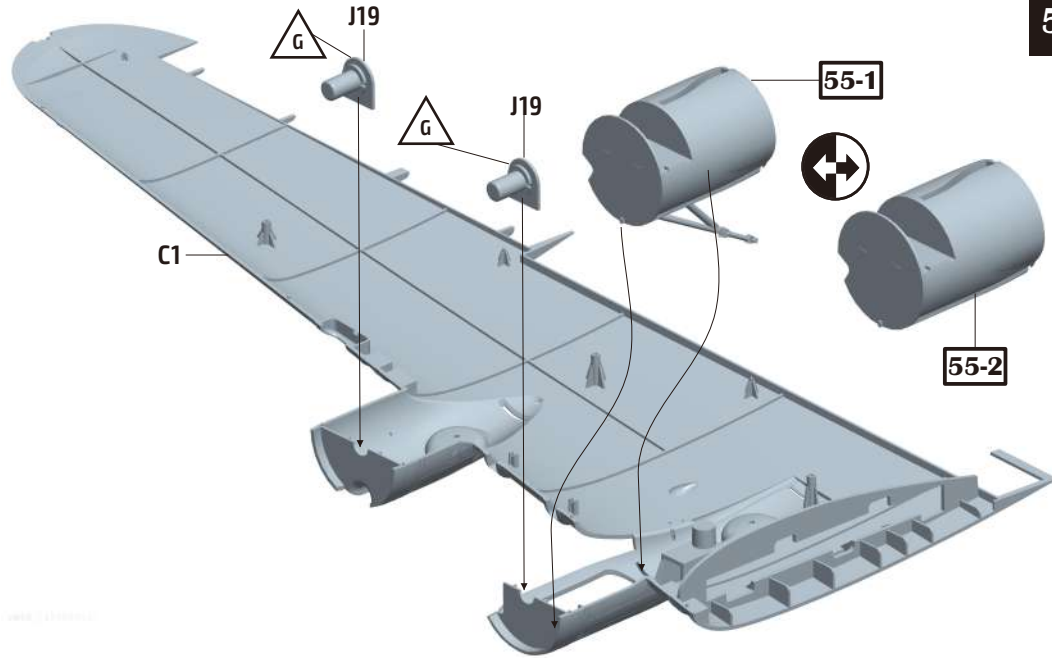
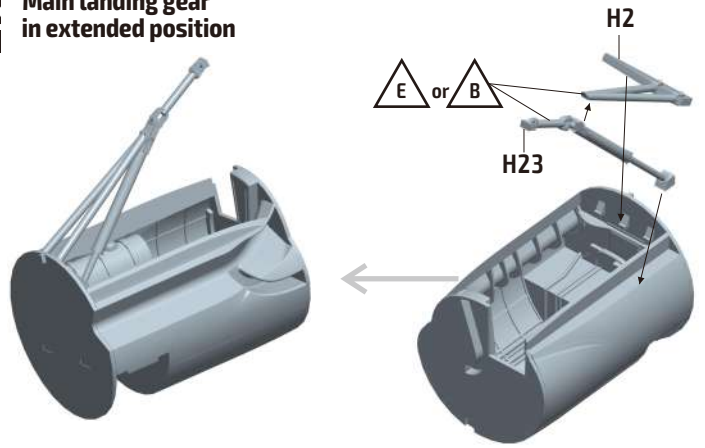

56

58

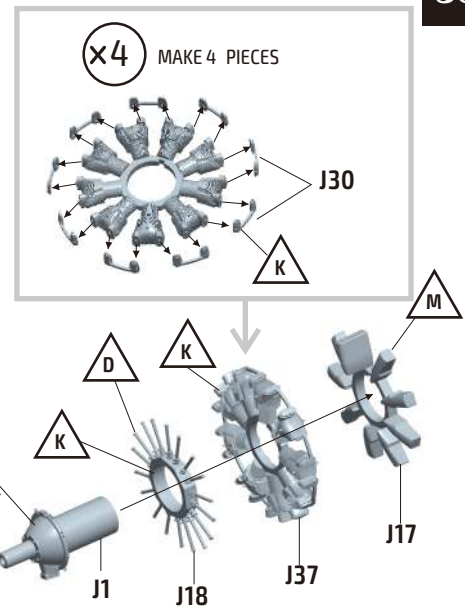

59

x4 MAKE 4 PIECES

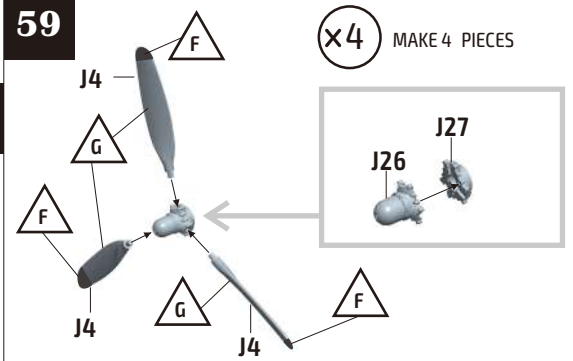

57

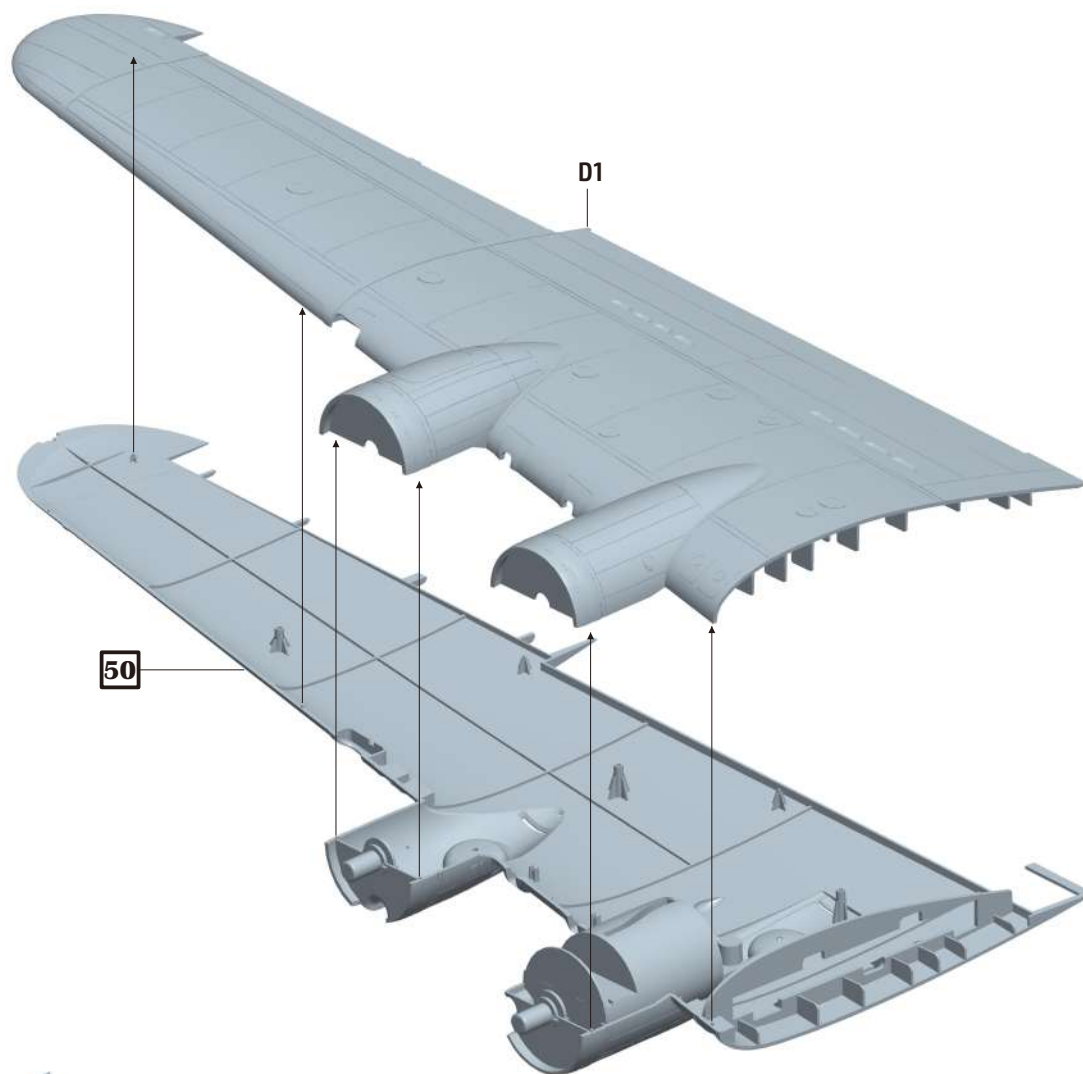

60

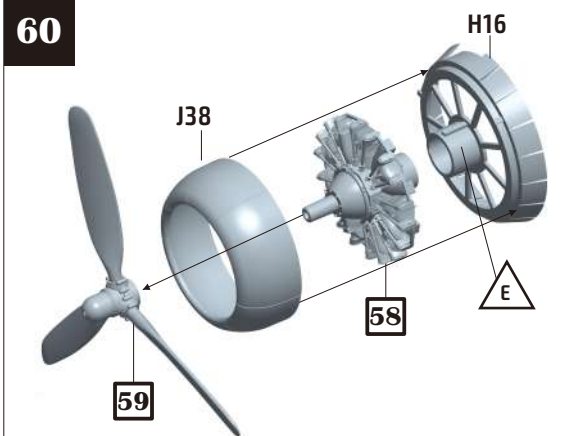

61

x2

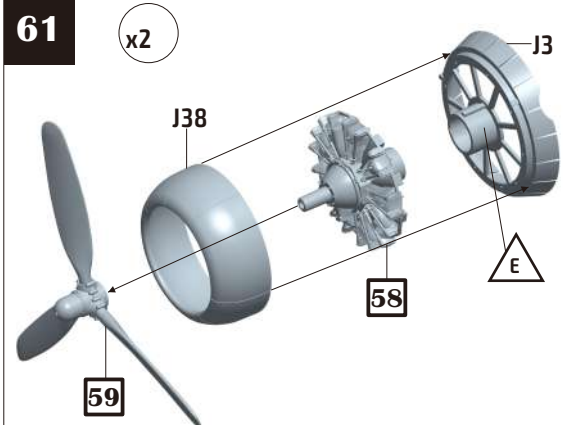

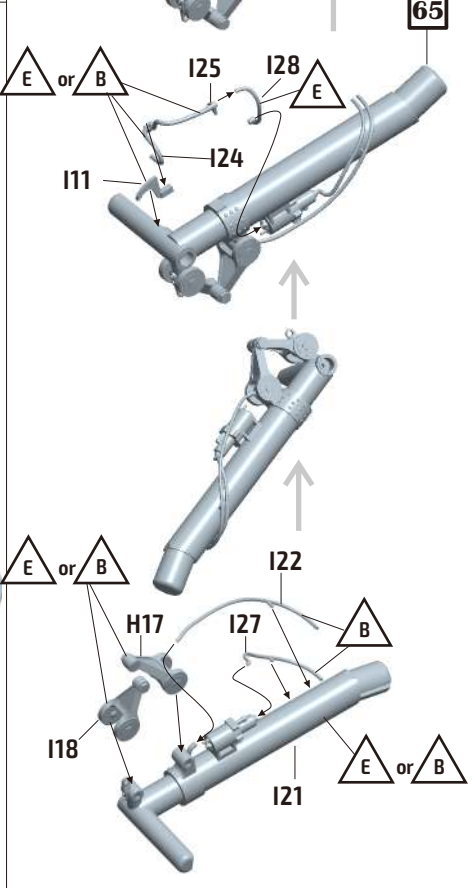
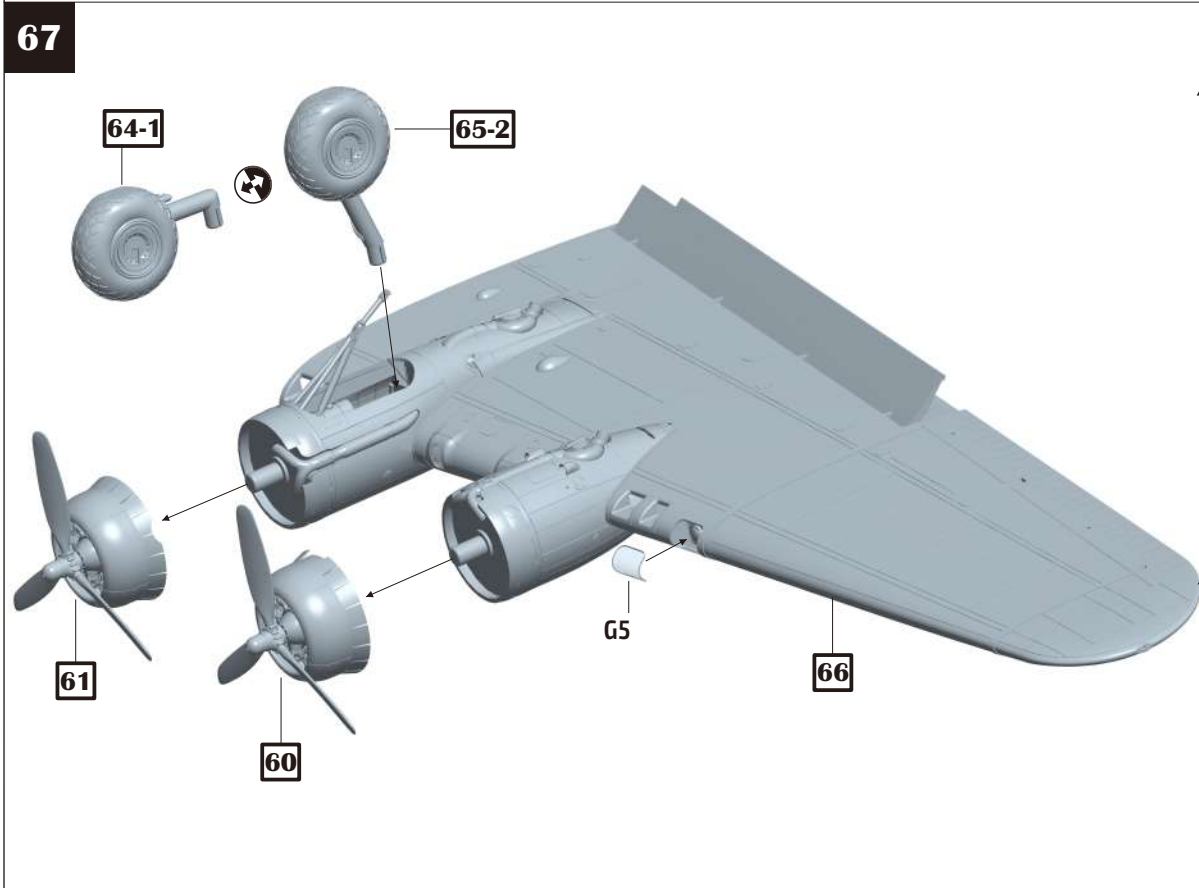
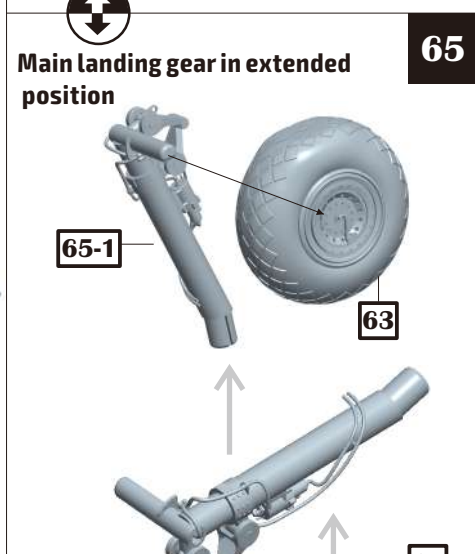
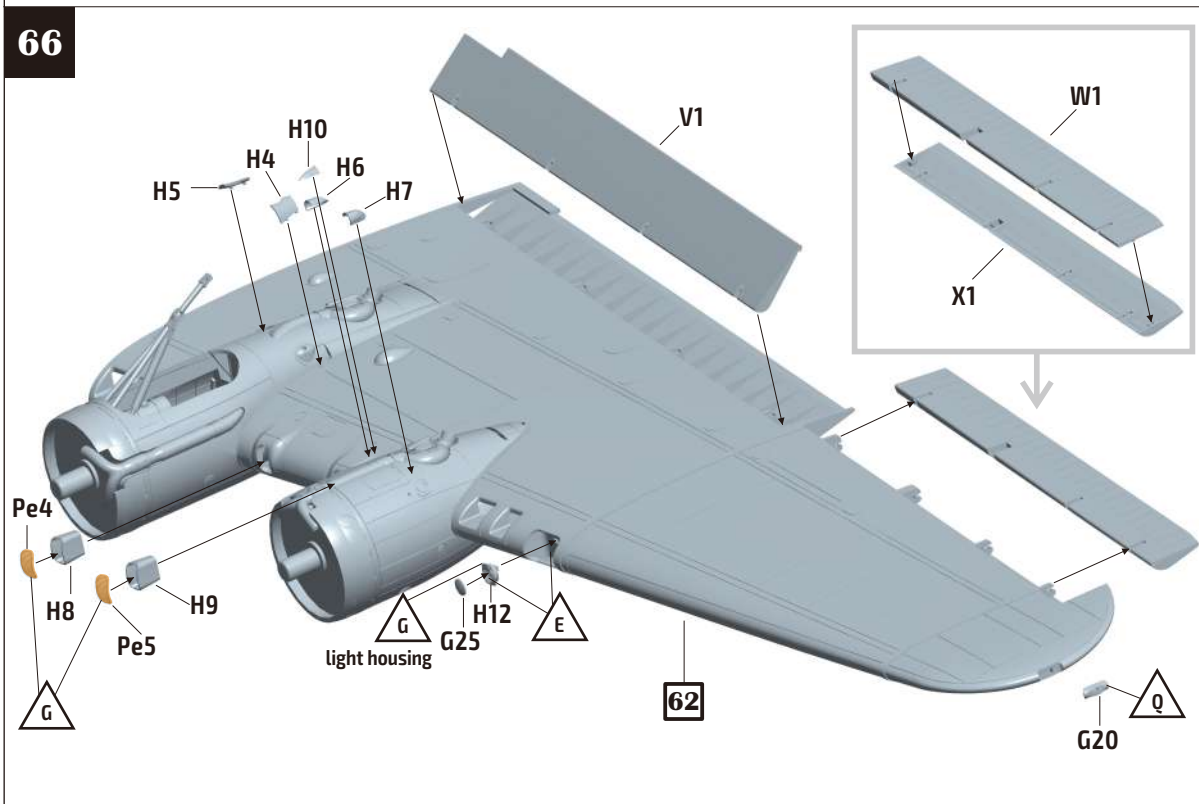
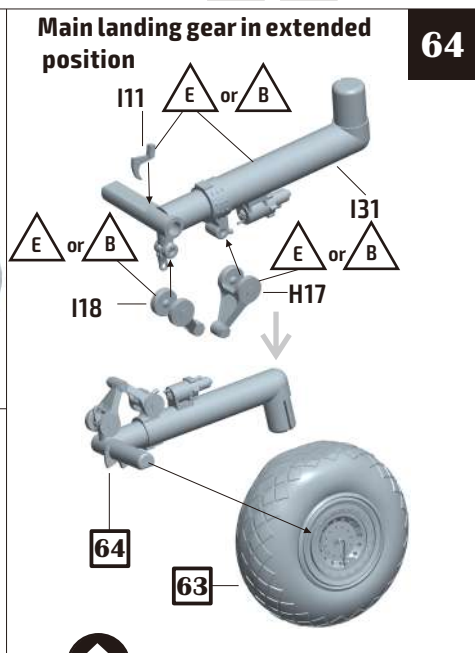
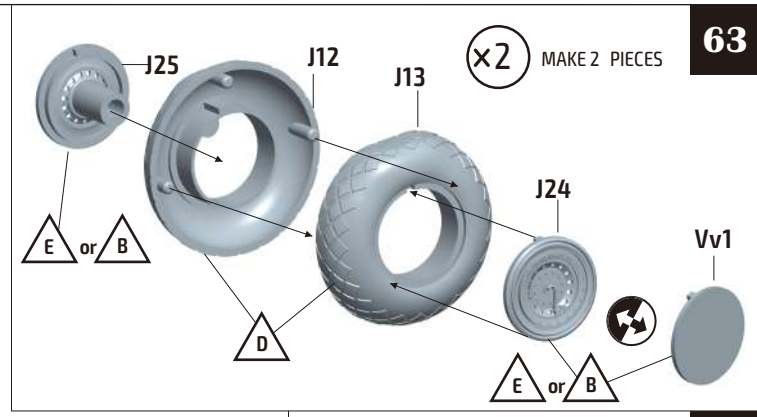
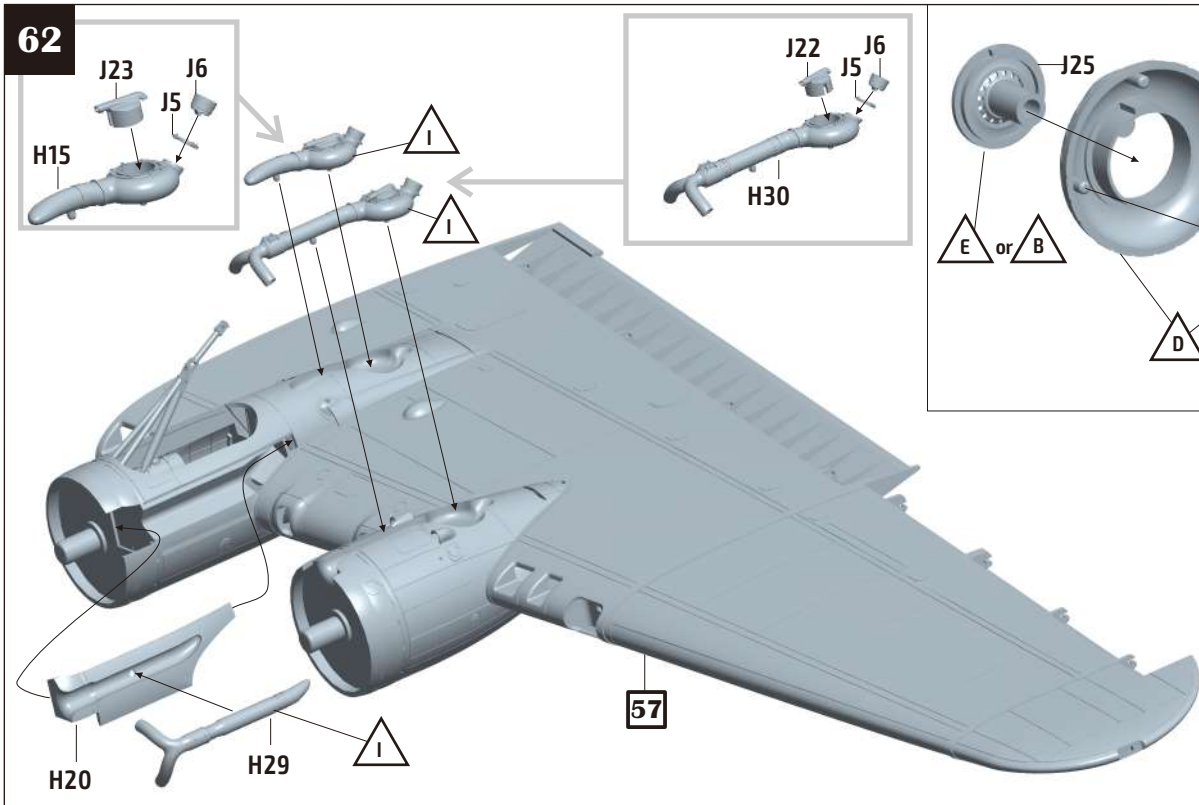

68 Main landing gear in retracted position

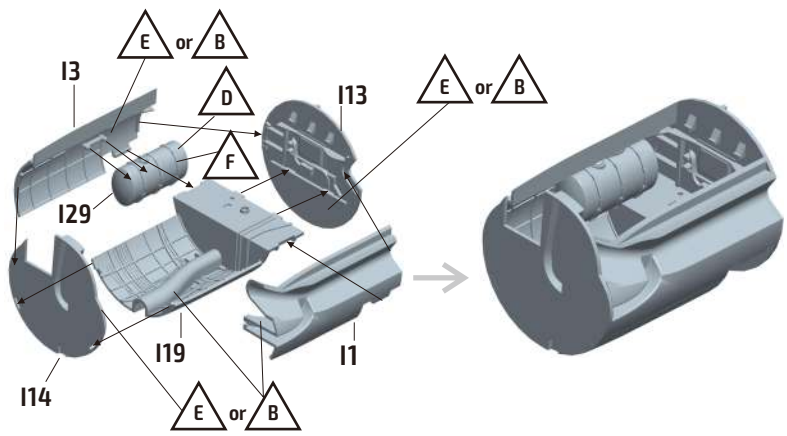

68-1

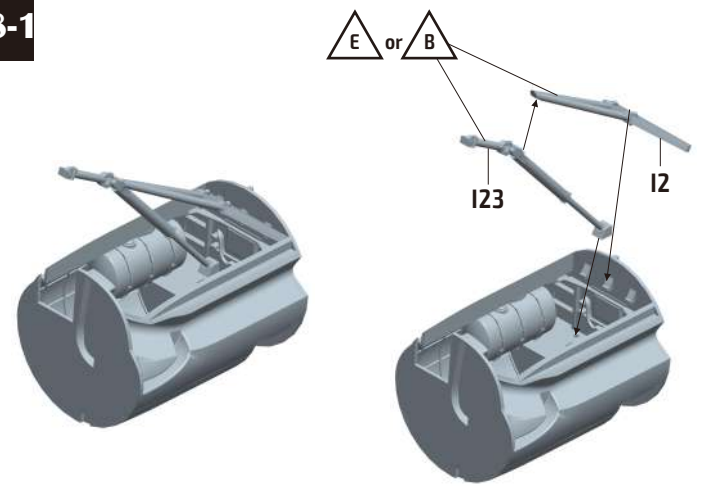

69

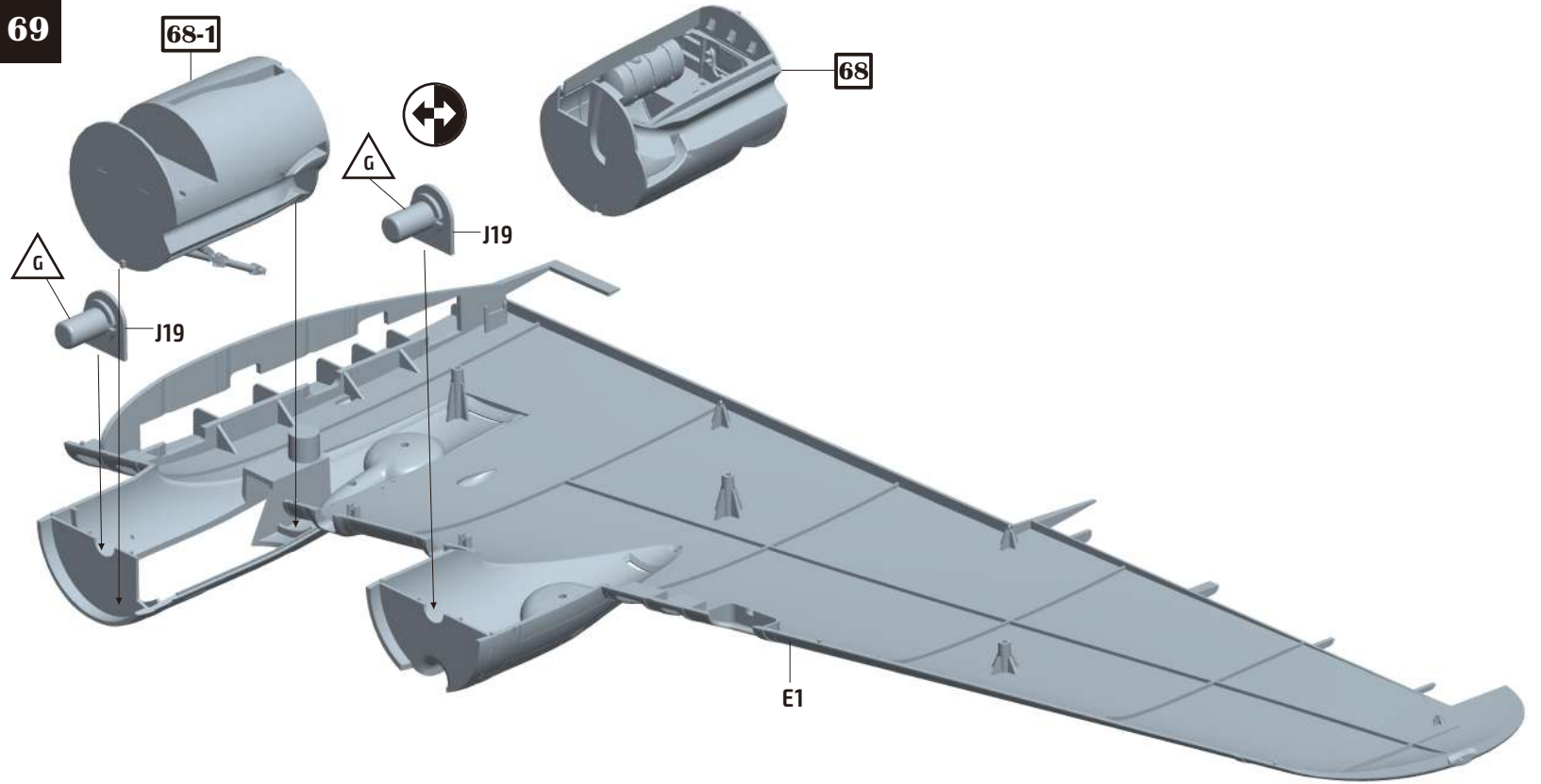

70

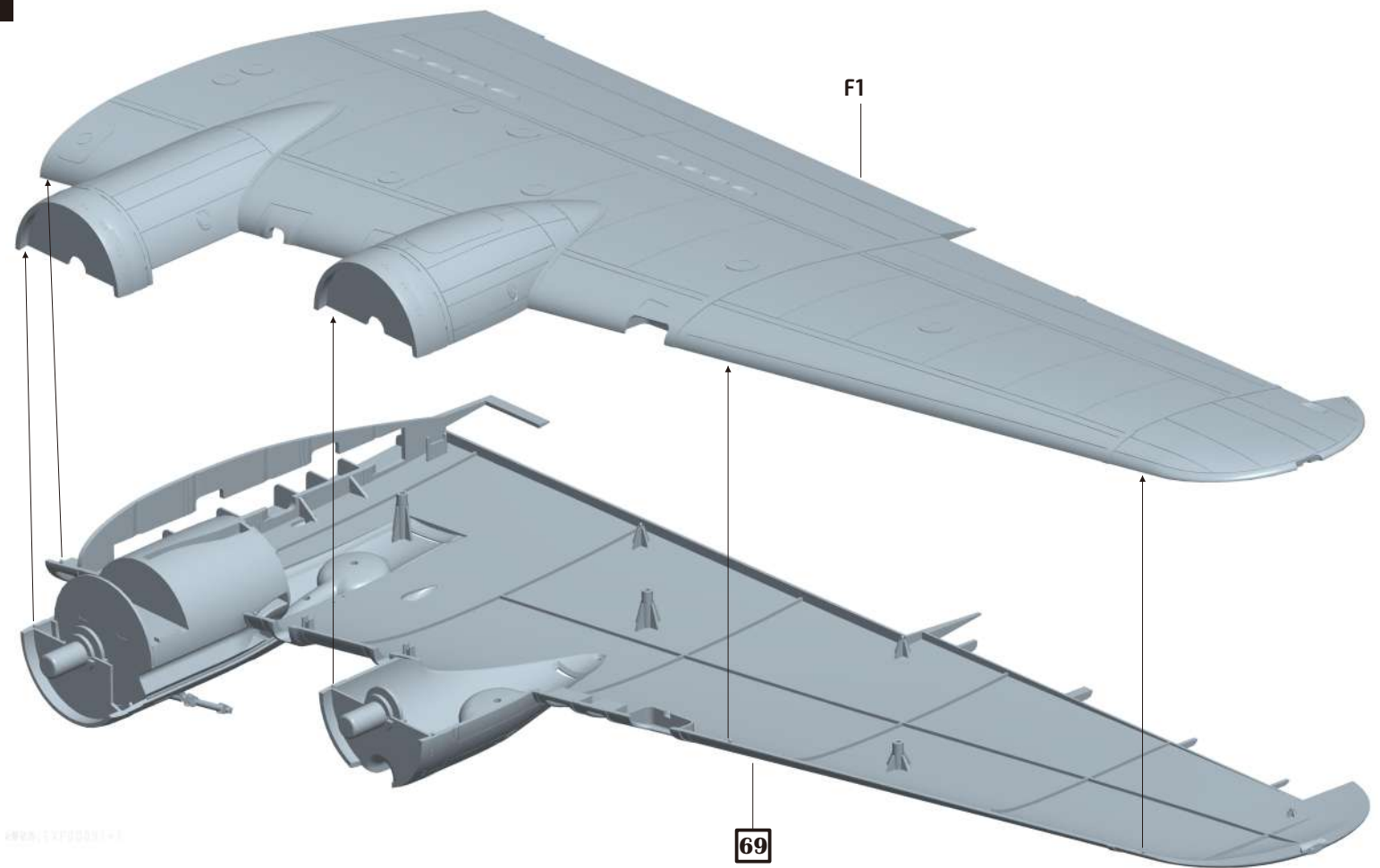

71

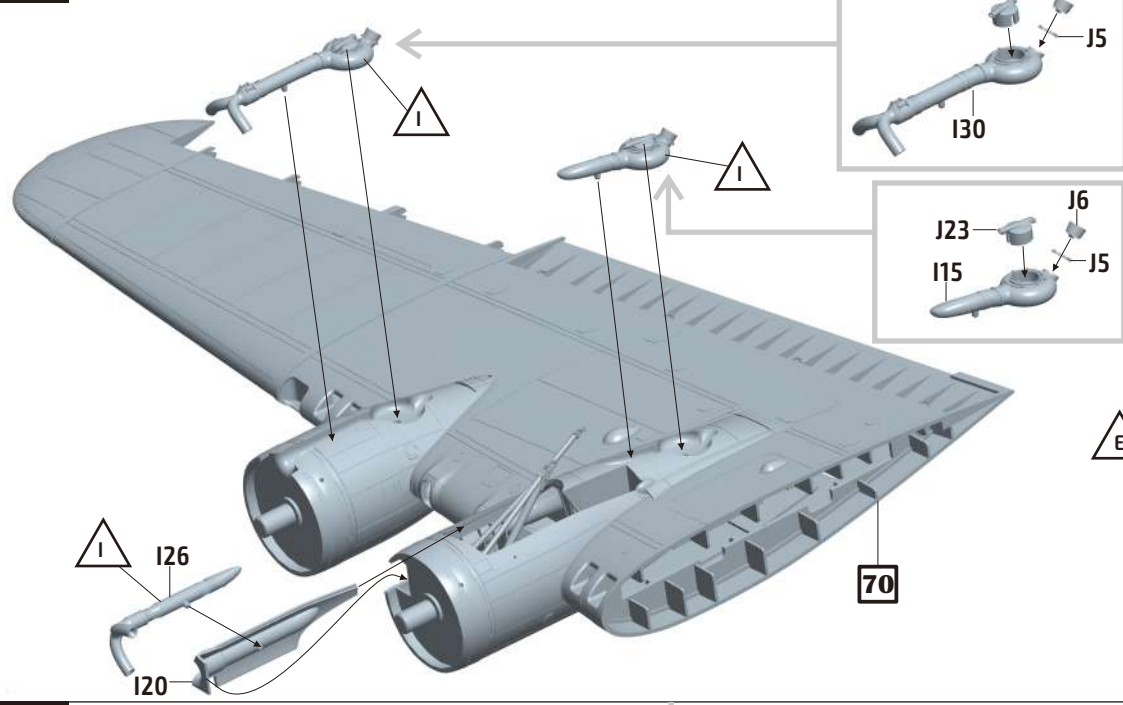

72

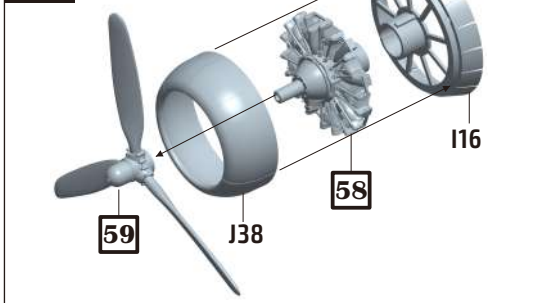

75

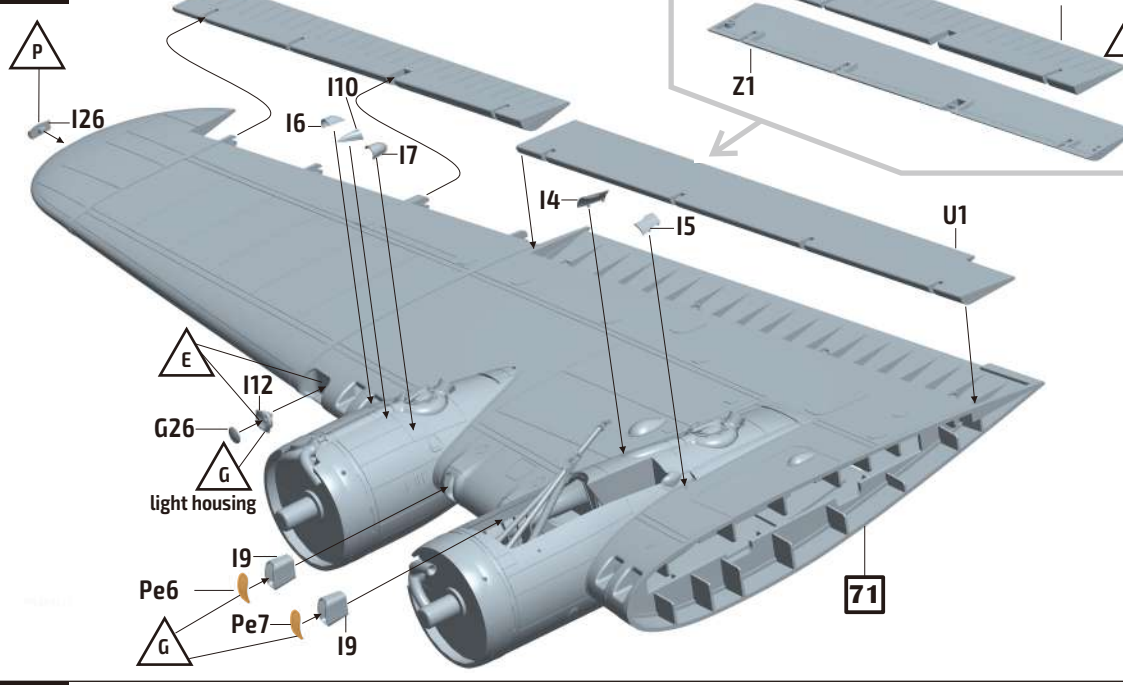

Main landing gear in extended position 73

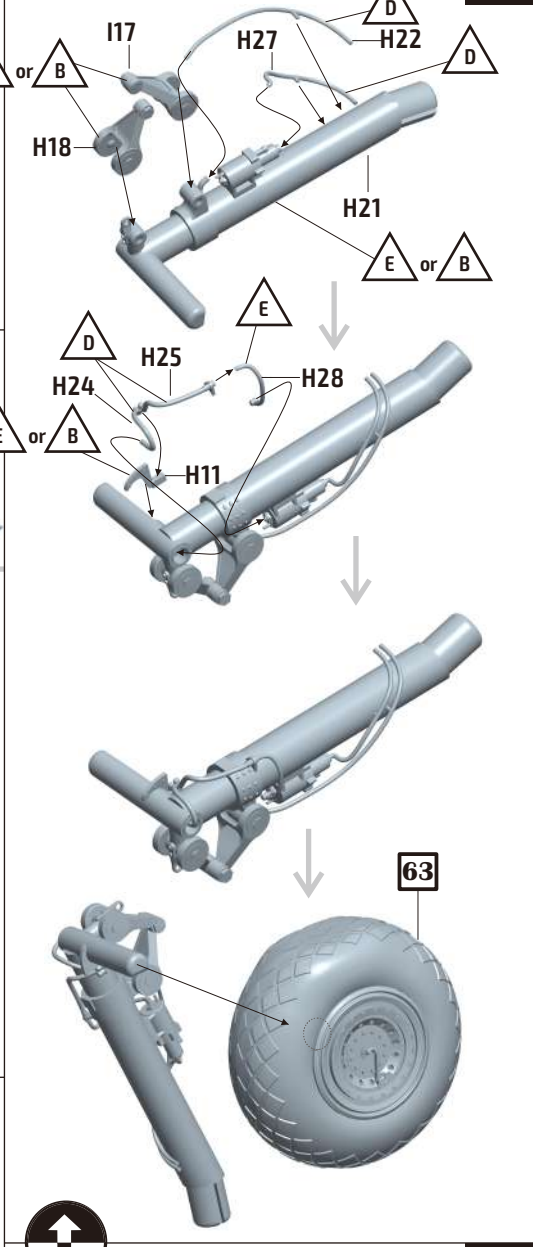

76

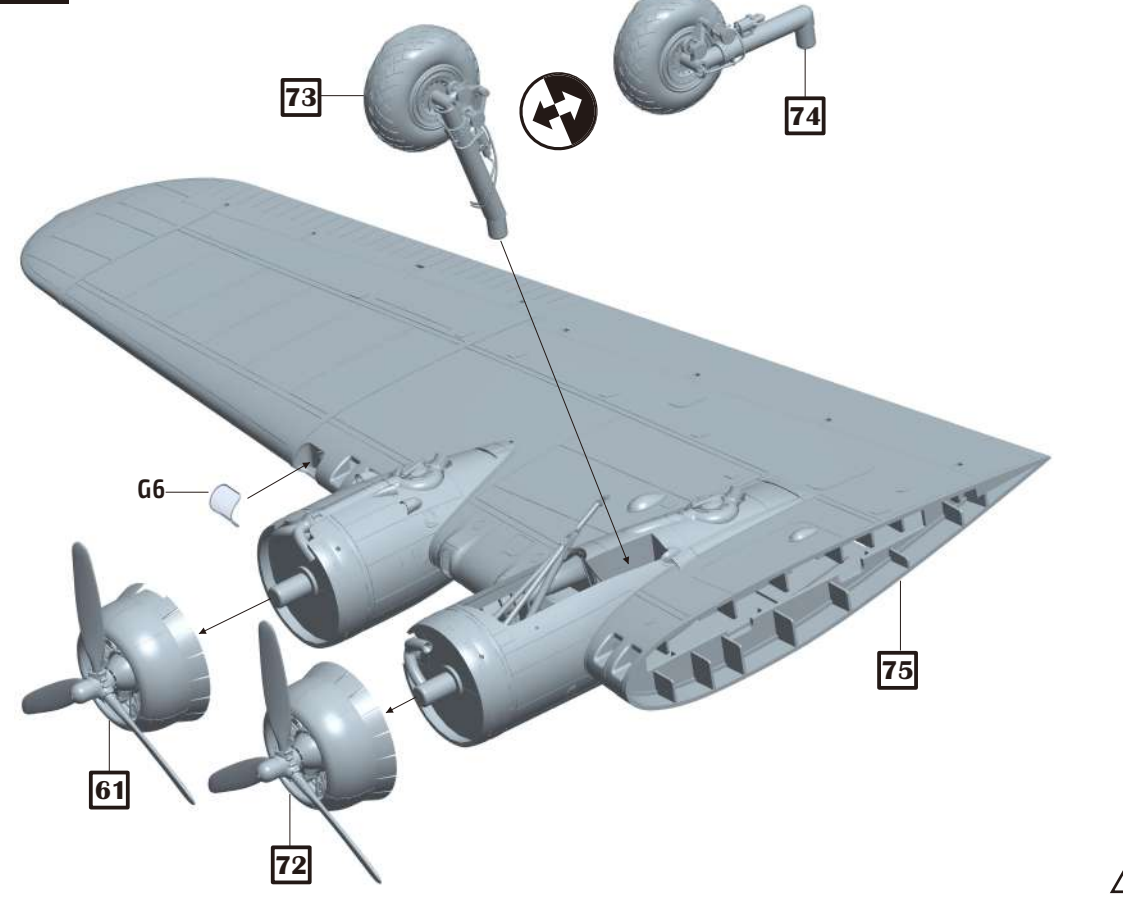

Main landing gear in retracted position 74

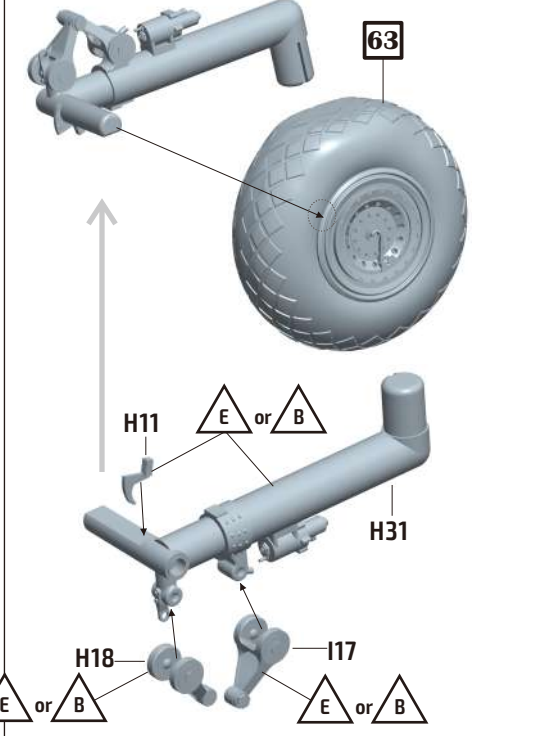

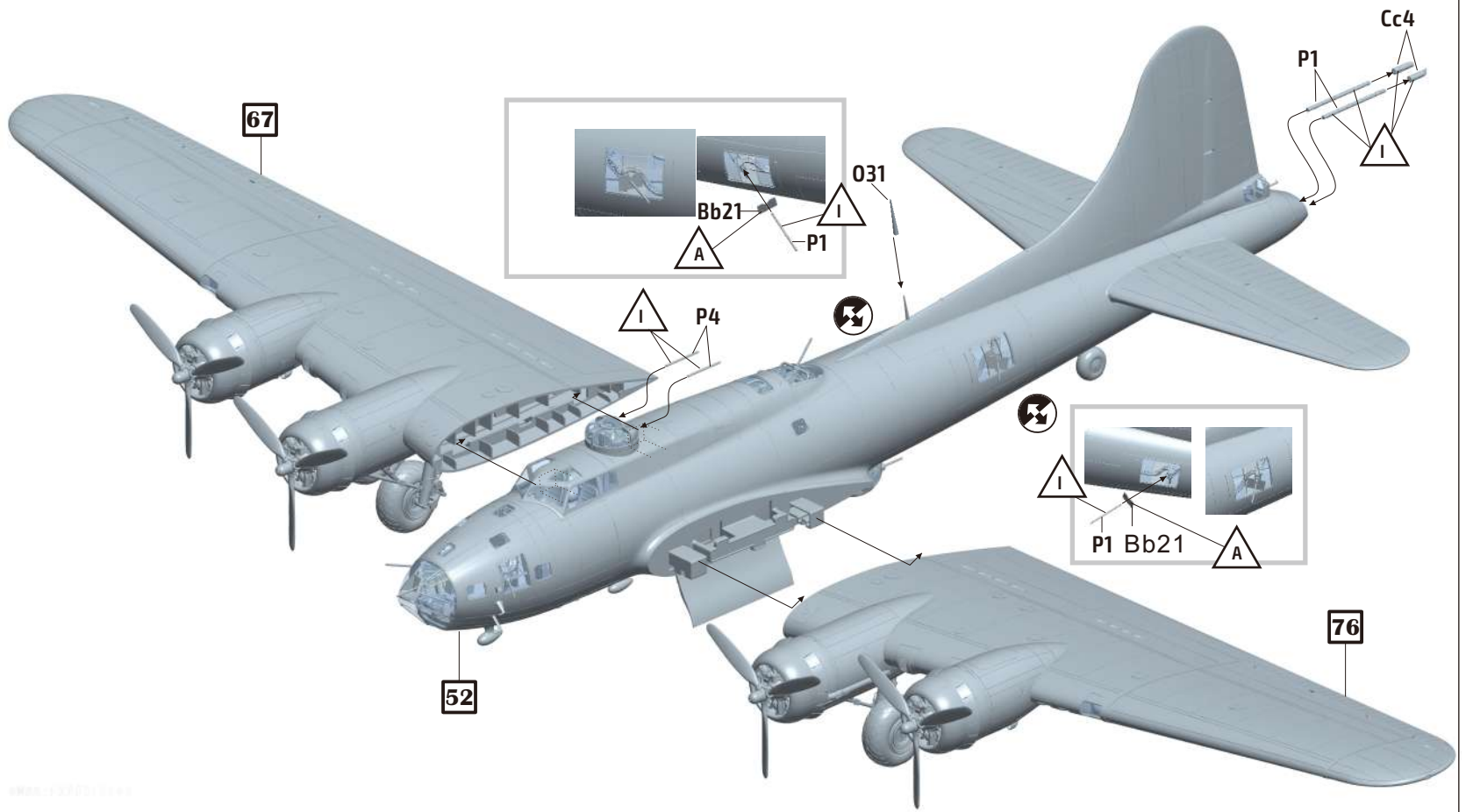

79

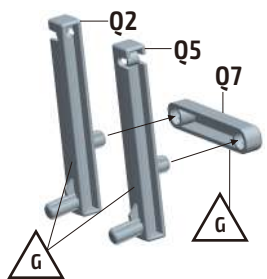

80

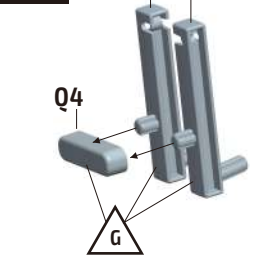

81

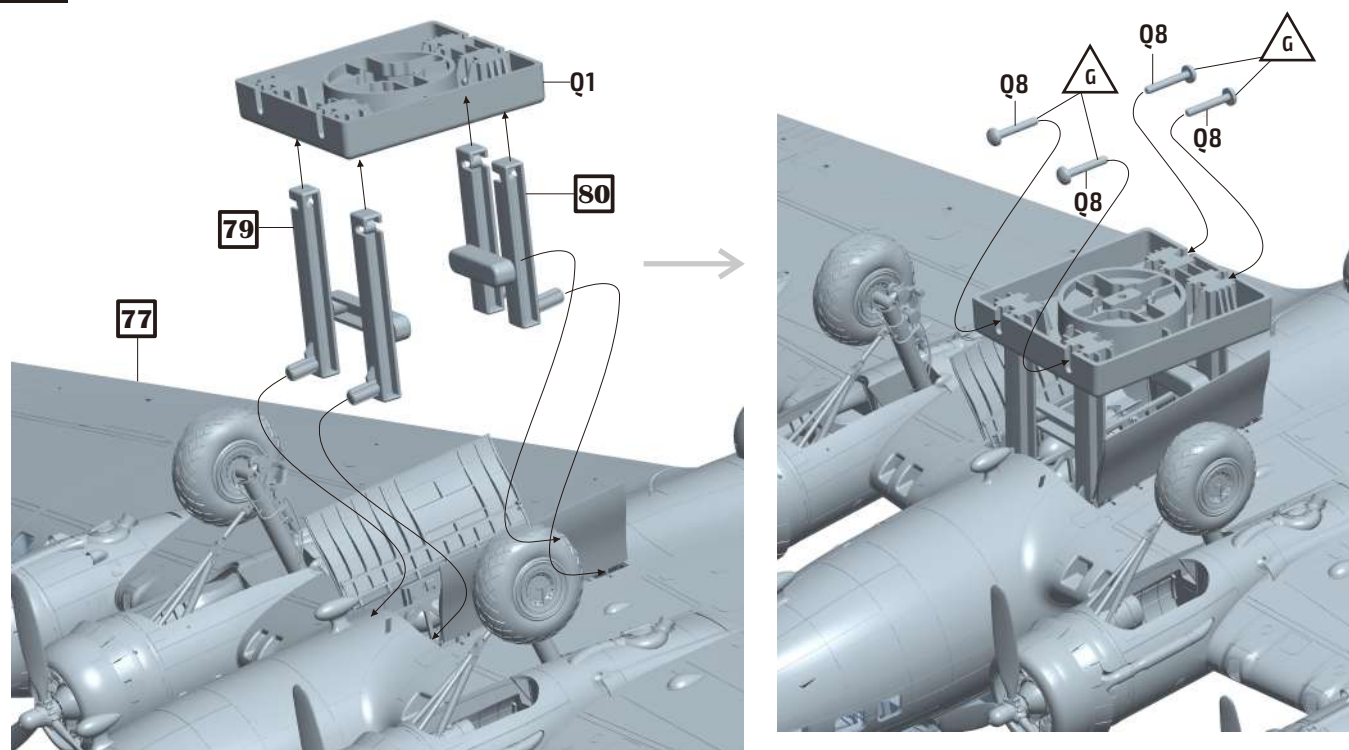

82

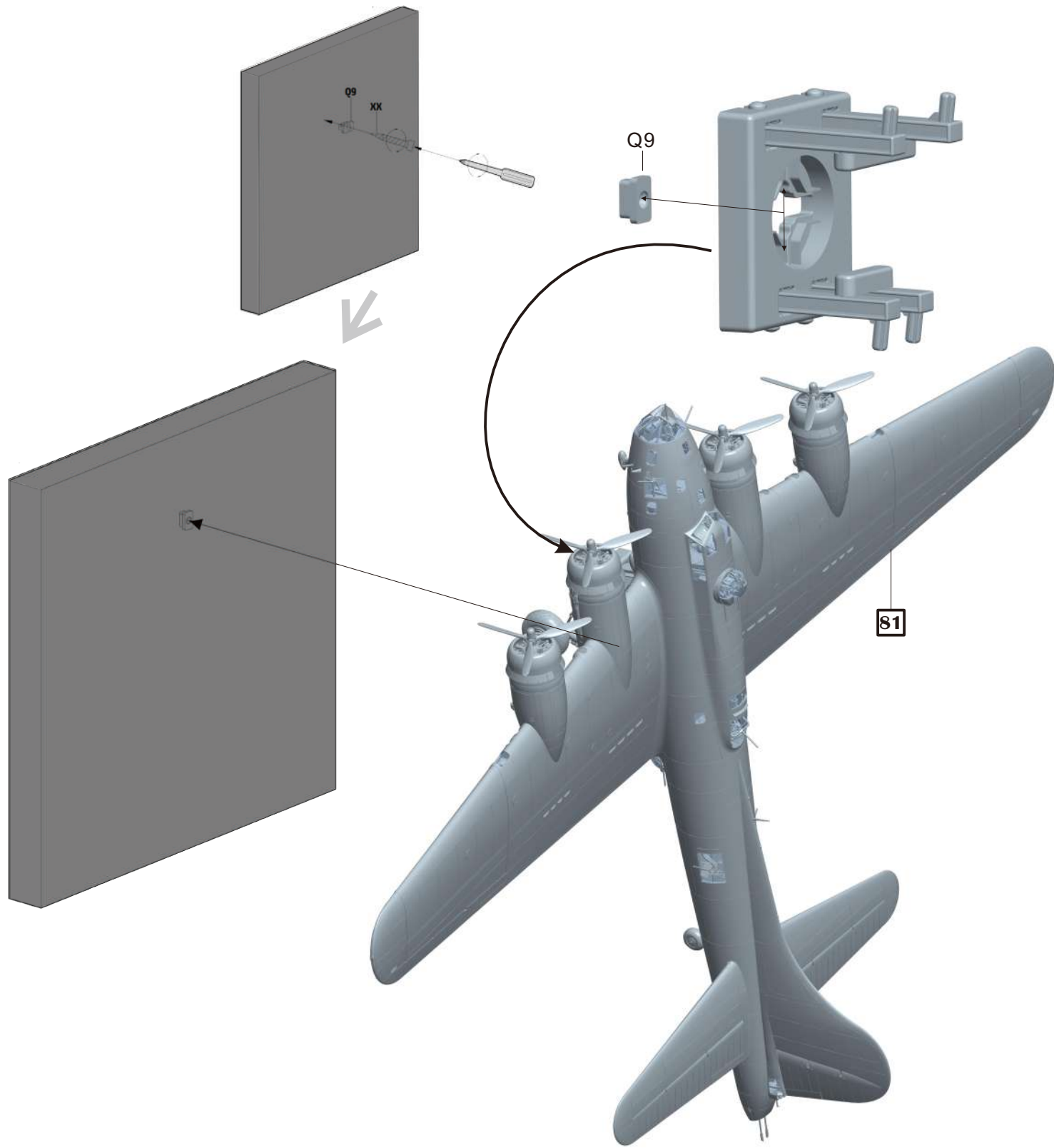

Parts

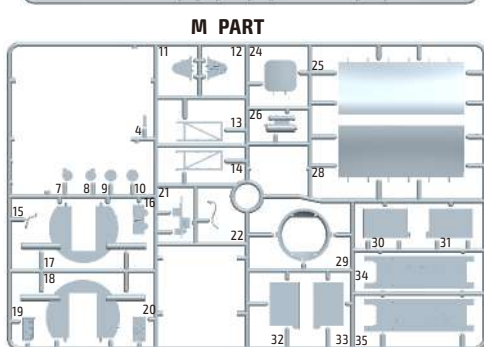
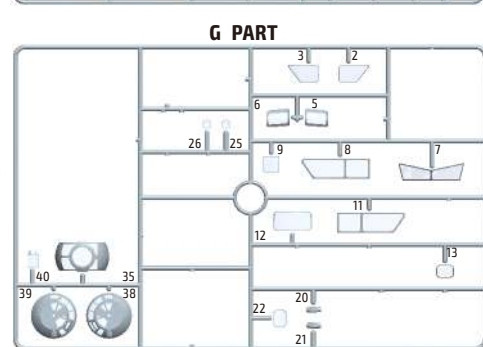
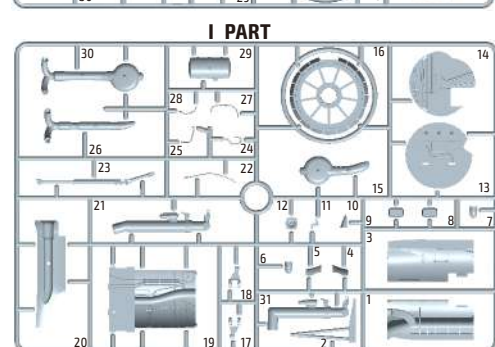
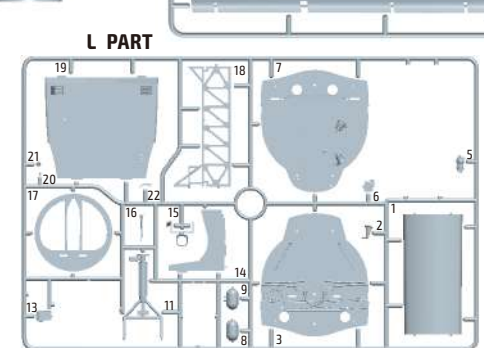
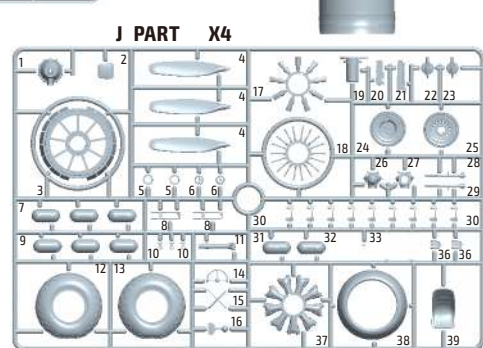
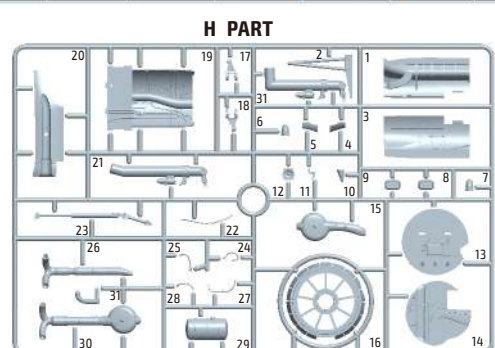
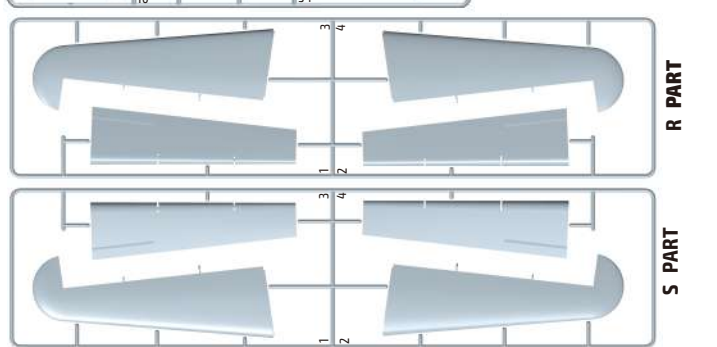
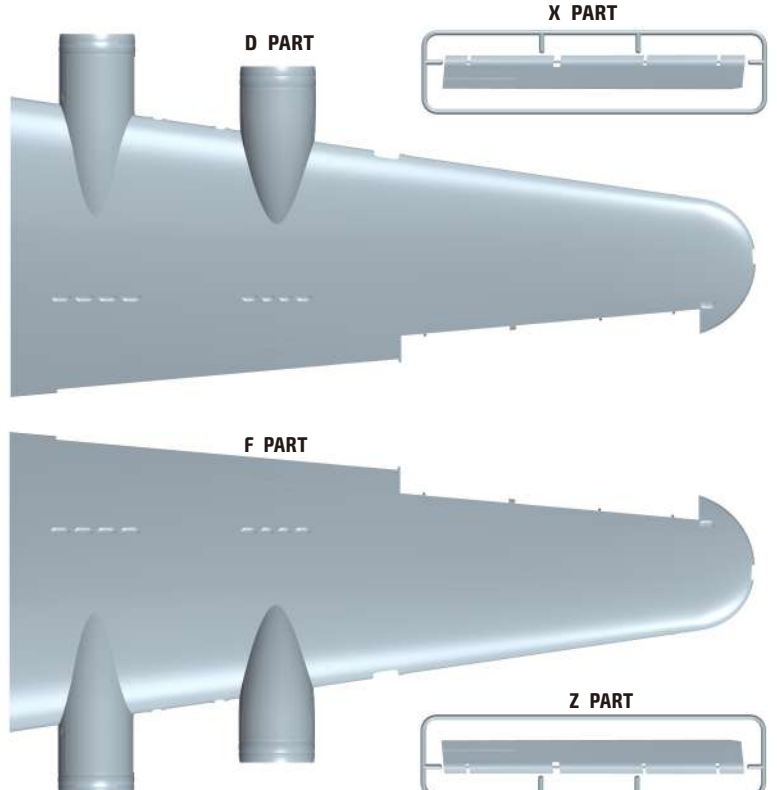
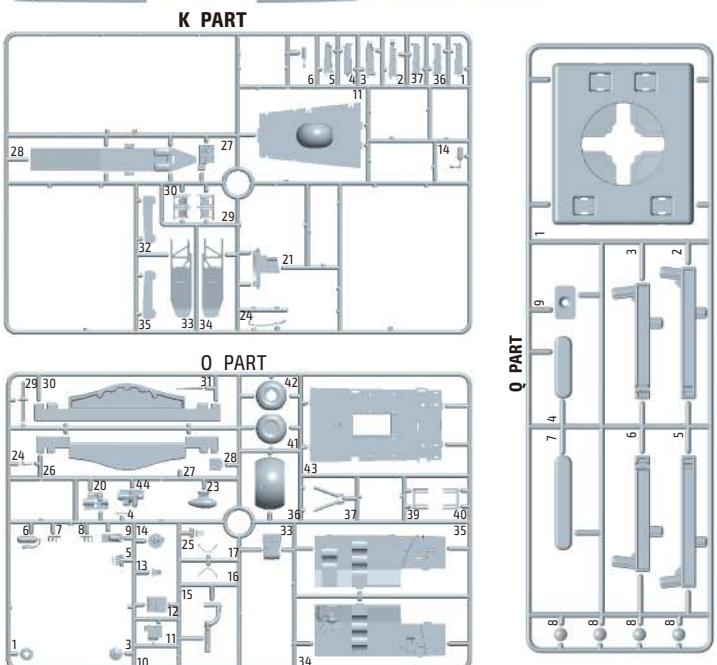
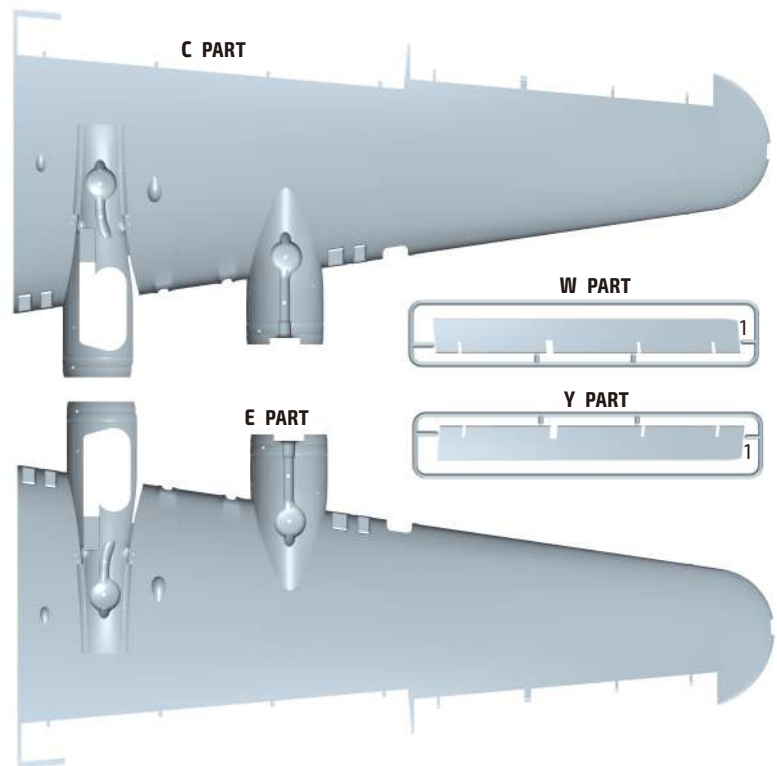
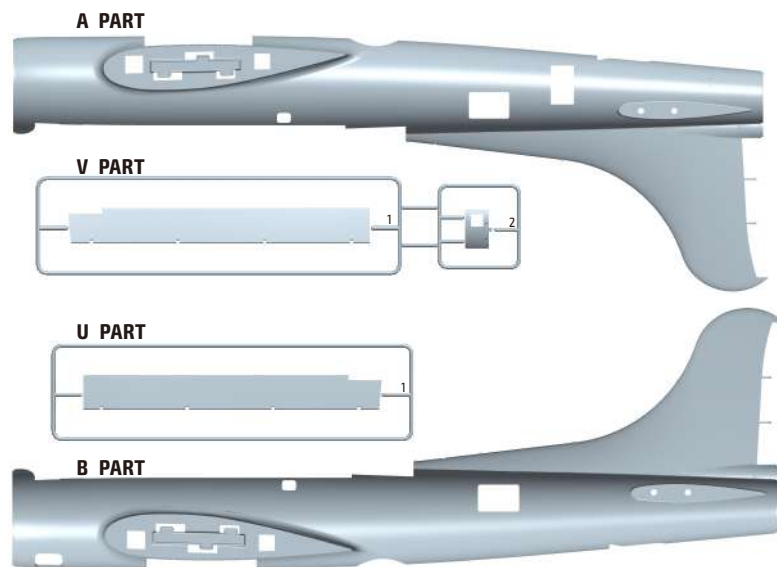

Parts

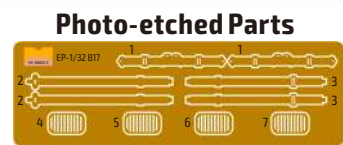
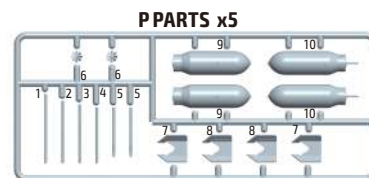
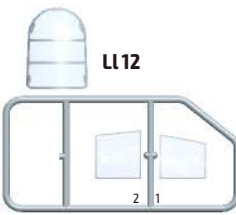
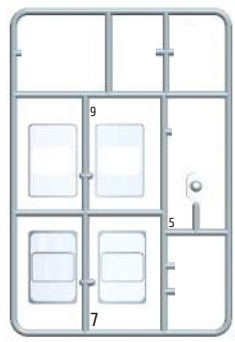
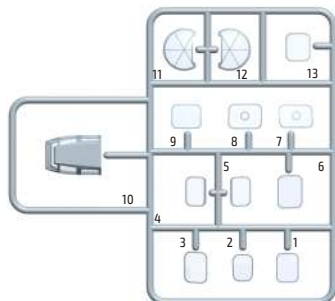
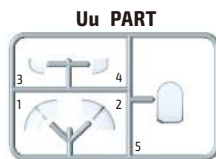
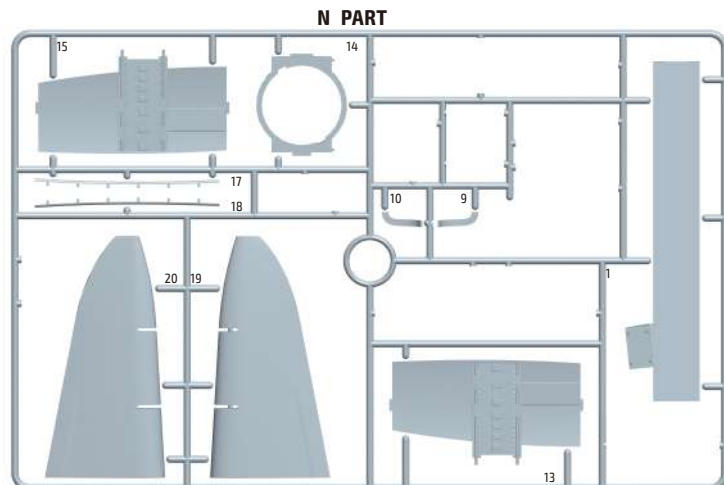
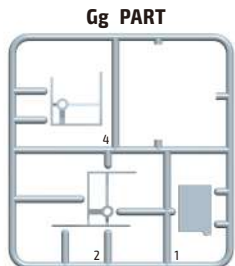
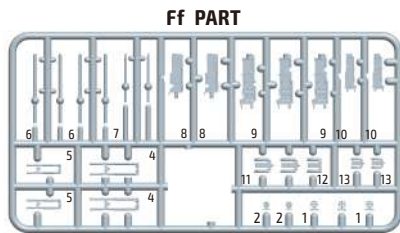
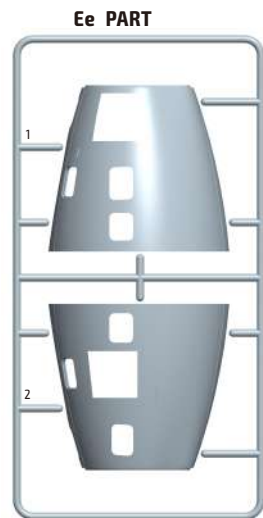
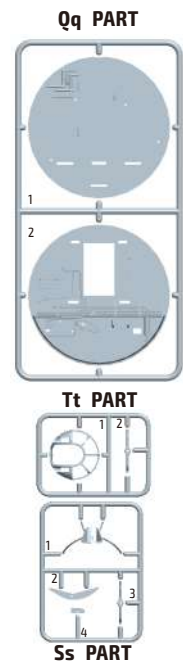
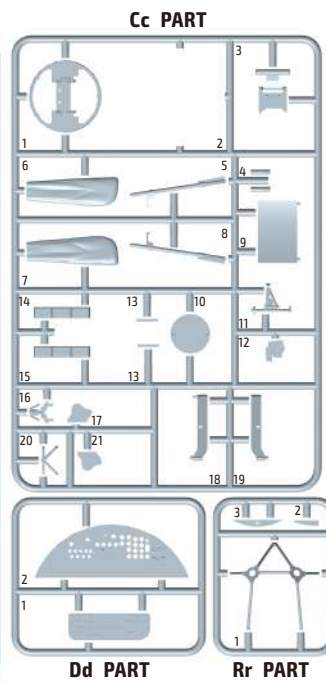
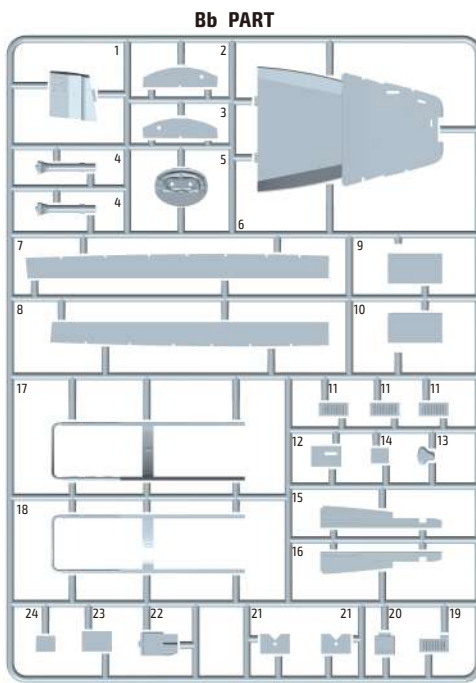
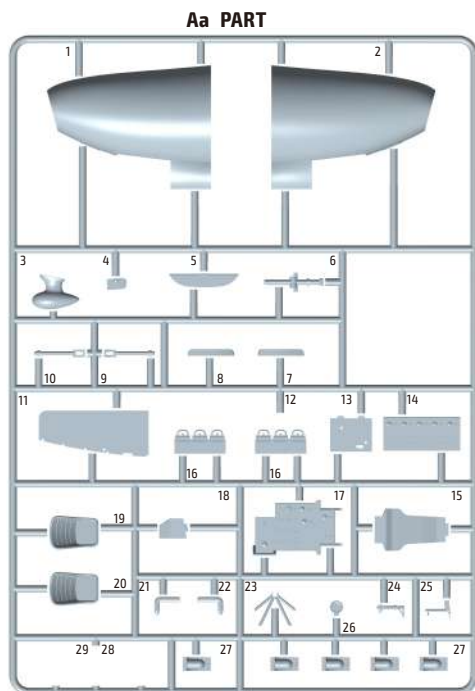

Resin Parts

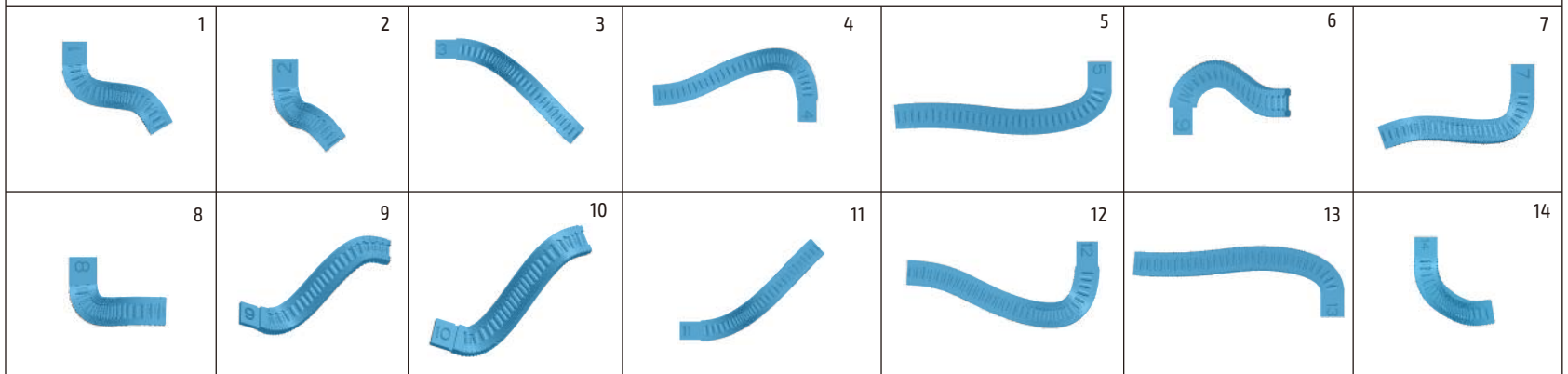

Decals

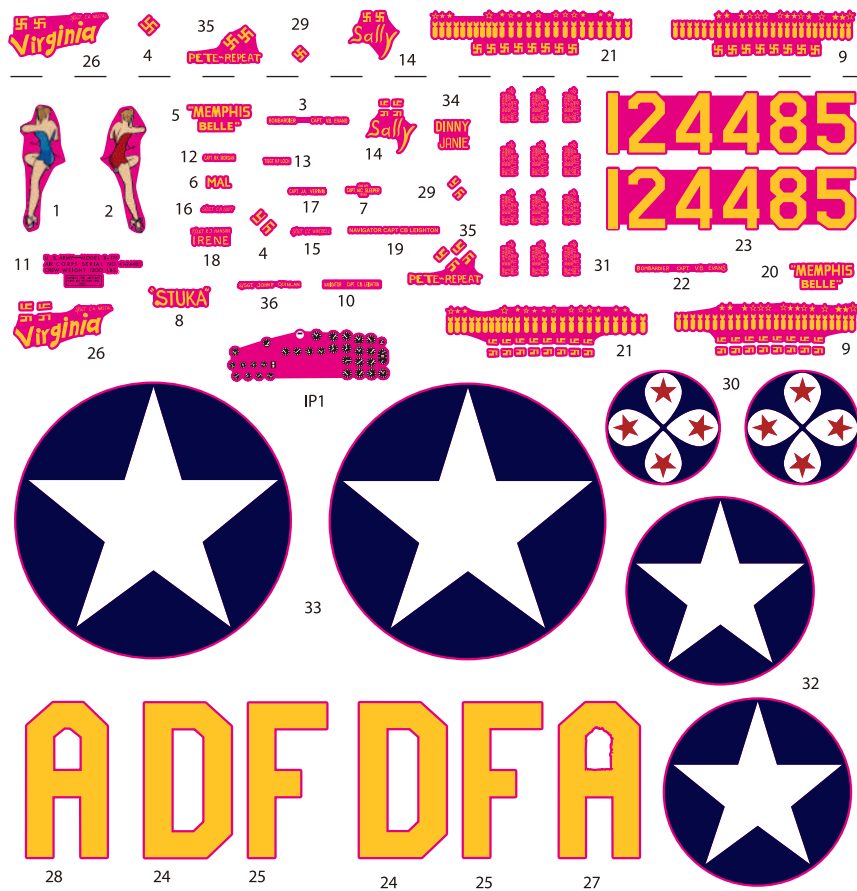

HK Models B-17F Flying Fortress 01E029 Part 1

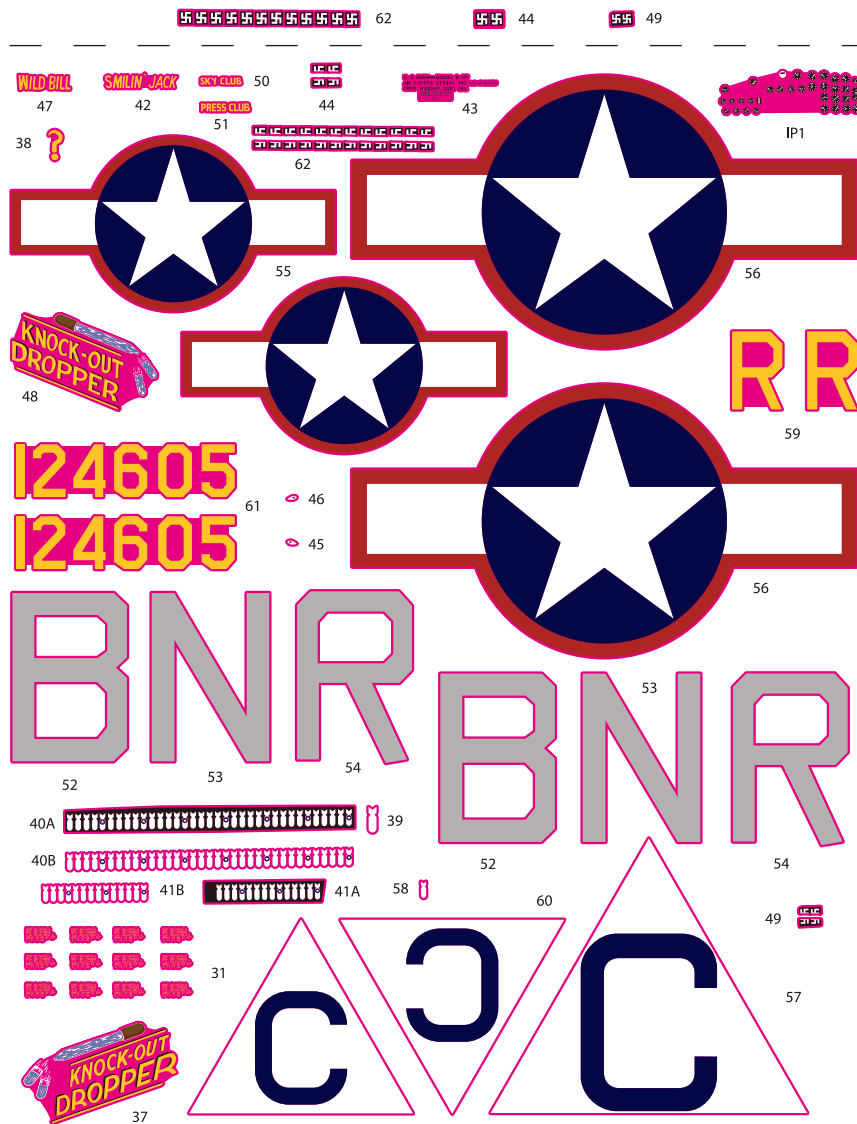

HK Models B-17F Flying Fortress 01E029 Part 2

MARKING

A

B-17F-10-B0, s/n 41-24485, DF-A, 324th BS / 91st BG, Bassingbourn, UK, May 1943

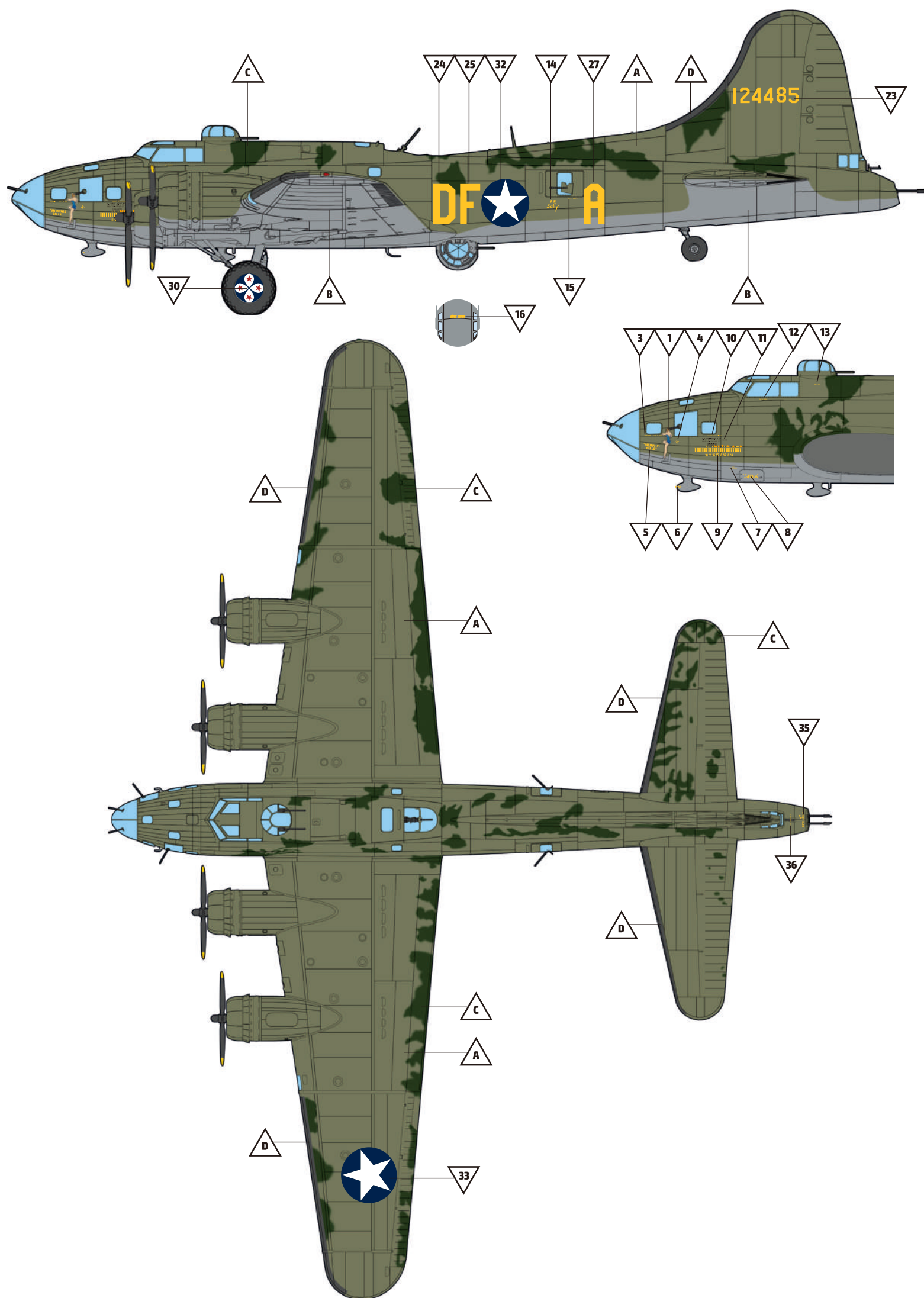

MARKING

A

B-17F-10-B0, s/n 41-24485, DF-A, 324th BS / 91st BG, Bassingbourn, UK, May 1943

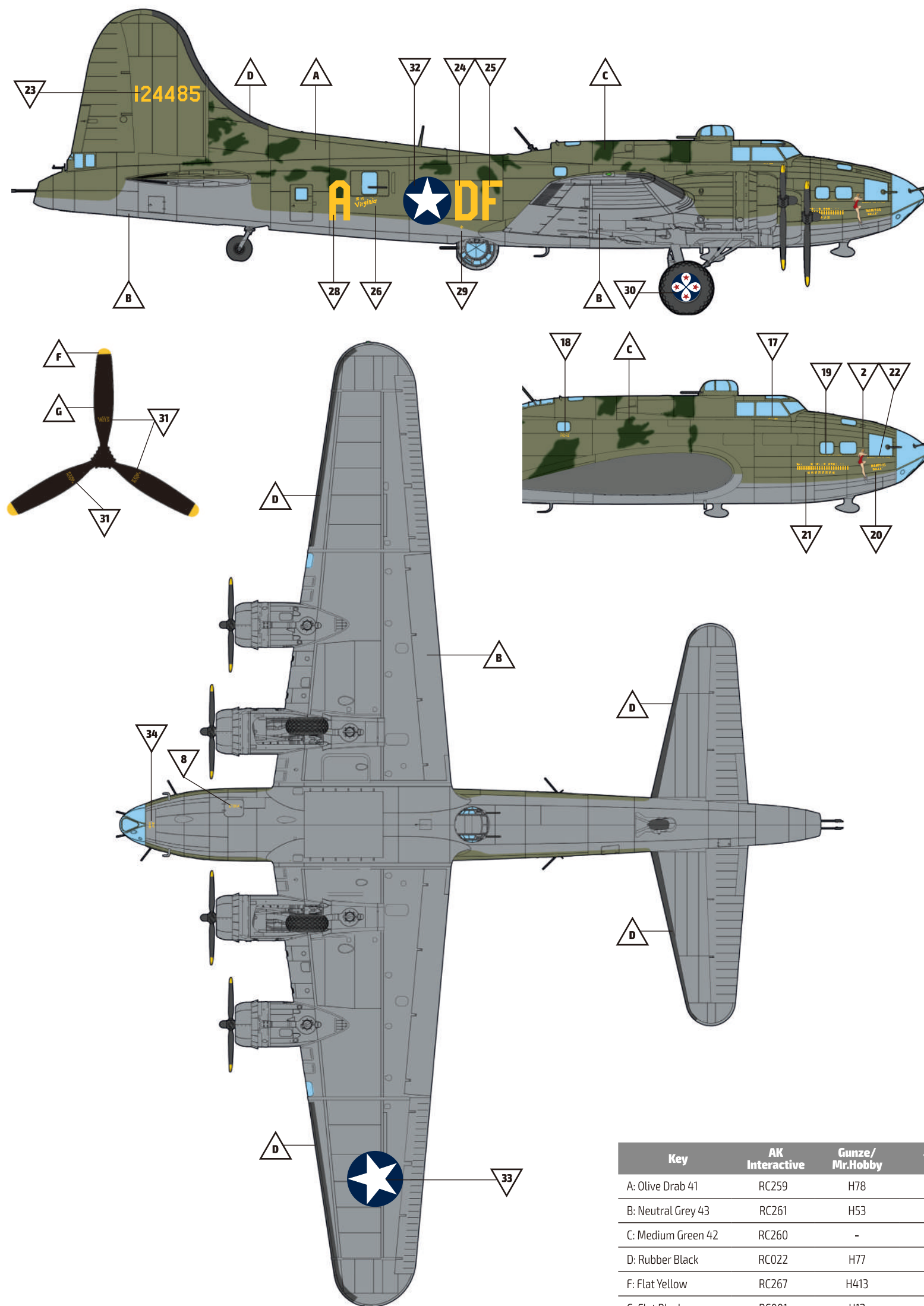

Key	AK Interactive	Gunze/ Mr.Hobby	Tamiya
A: Olive Drab 41	RC259	H78	XF-62
B: Neutral Grey 43	RC261	H53	XF-53
C: Medium Green 42	RC260	-	-
D: Rubber Black	RC022	H77	XF-85
F: Flat Yellow	RC267	H413	XF-3
G: Flat Black	RC001	H12	XF-1

MARKING

B

B-17F-27-B0, s/n 41-24605, BN-R, 359th BS / 303rd BG, Molesworth, UK, November 1943

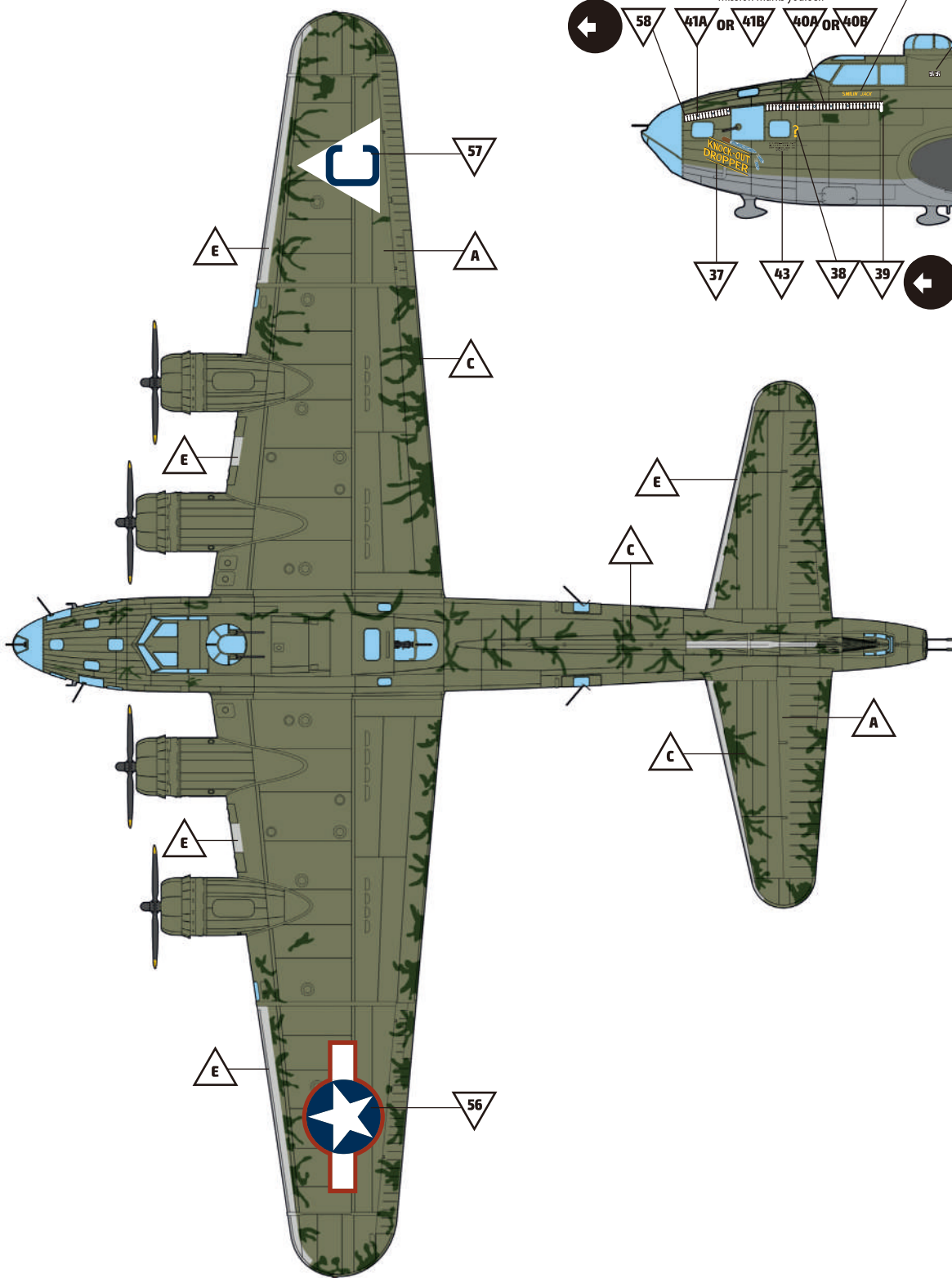
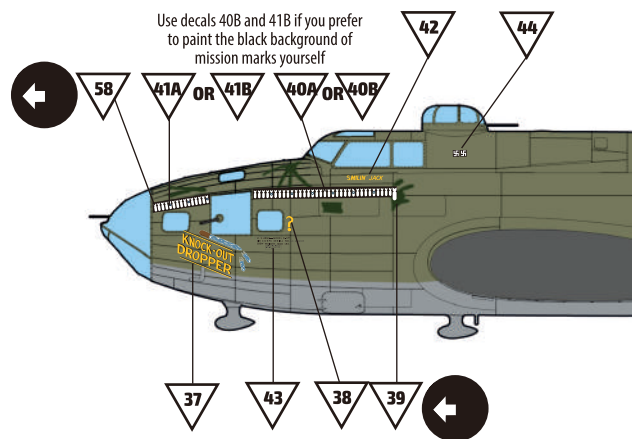
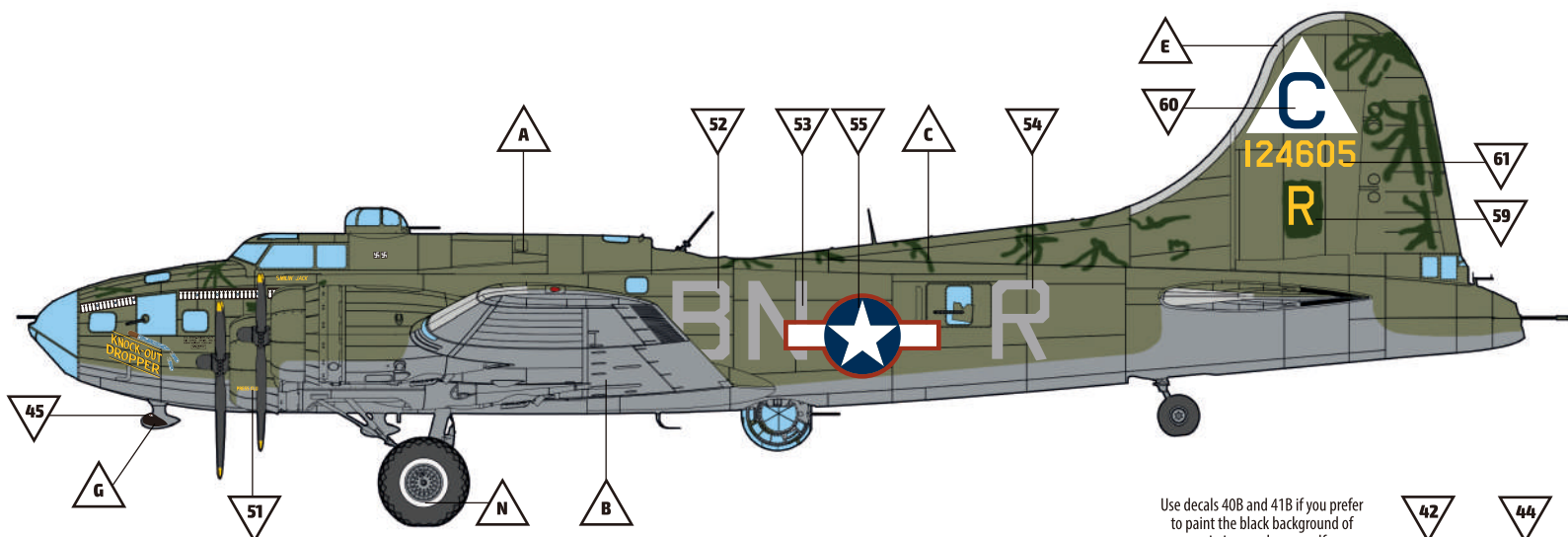

MARKING

B

B-17F-27-B0, s/n 41-24605, BN-R, 359th BS / 303rd BG, Molesworth, UK, November 1943

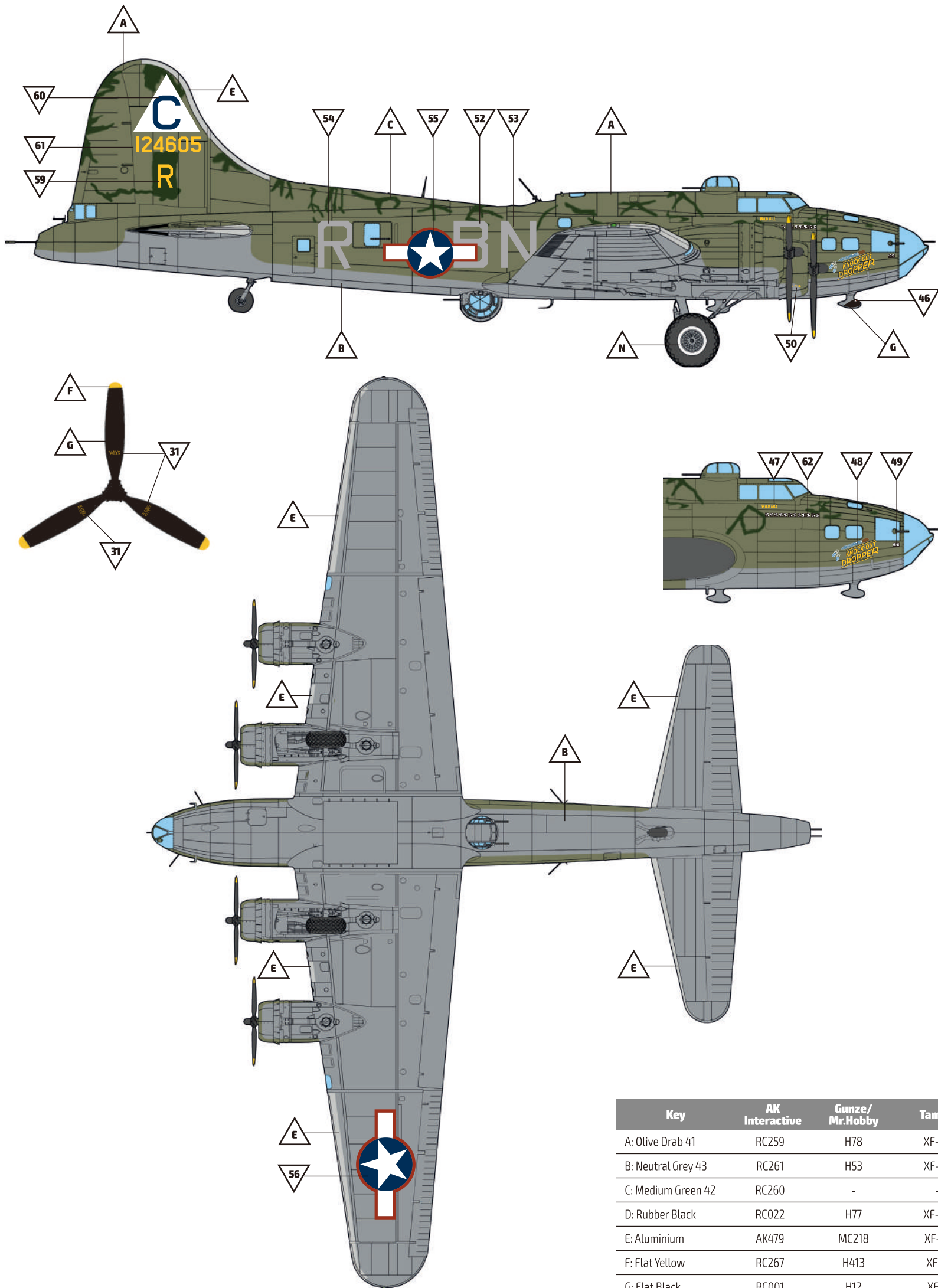

Key	AK Interactive	Gunze/ Mr.Hobby	Tamiya
A: Olive Drab 41	RC259	H78	XF-62
B: Neutral Grey 43	RC261	H53	XF-53
C: Medium Green 42	RC260	-	-
D: Rubber Black	RC022	H77	XF-85
E: Aluminium	AK479	MC218	XF-16
F: Flat Yellow	RC267	H413	XF-3
G: Flat Black	RC001	H12	XF-1
N: White	RC004	H11	XF-2

Colour Guide

Key	AK Interactive	Gunze/Mr.Hobby	Tamiya
A: Olive Drab 41	RC259	H78	XF-62
B: Neutral Grey 43	RC261	H53	XF-53
C: Medium Green 42	RC260	-	-
D: Rubber Black	RC022	H77	XF-85
E: Aluminium	AK479	MC218	XF-16
F: Flat Yellow	RC267	H413	XF-3
G: Flat Black	RC001	H12	XF-1
H: Dull Dark Green	RC230	H302	XF-26
I: Gunmetal	RC015	MC214	X-10
J: Brass	AK475	MC219	X-12
K: Steel	AK476	H18	XF-56
L: Light Wood	RC014	H79	XF-78
M: Grey	RC296	H331	XF-77
N: White	RC004	H11	XF-2
O: Light Green	AK11134	H50	XF-71:4 + XF-2:1
P: Clear Red	RC503	H90	X-27
Q: Clear Green	RC505	H94	X-25

In cooperation with:



Illustration, manual layout and format: **Tomek Wajnka & AK-Interactive**
Manual and assistance: **AK-Interactive**

