

Plastic model kit containing 625 parts. Photo-etched parts and Cartograf decals included.

Wing span: 989mm Length: 707mm

1/32
SCALE



B-17G Flying Fortress

Late Production

The Boeing B-17 'Flying Fortress' was one of the U.S.A.'s main four-engine heavy bombers, operating alongside the B-24 Liberator, and the later B-29 Superfortress, in all theatres of World War 2. It's a fact that the B-17 almost never saw its place in history and the defeat of Nazi Germany, as the prototype, known as Model 299, crashed due to pilot error during its evaluation in October 1935. Thankfully, the design had shown such promise during the testing phase, in fact, far exceeding the requirements of the original specification, that further prototypes were ordered despite Boeing losing the original contract with the United States Army Air Corps. It was this further evaluation that saw the type enter active service in 1938. The actual name 'Flying Fortress' was coined by a newspaper hack who witnessed a roll-out of the machine, bristling with guns and turrets, and Boeing realised that this was the sort of propaganda they needed, and trademarked the name. After the initial prototypes, serial production of the B-17 began with the B-17B variant, and underwent a major revision with the introduction of the 'E'. This type featured a substantially redesigned tail and fillet that featured throughout subsequent versions, giving the B-17 its iconic profile. An extra 10ft of length was added to the fuselage. Other refinements included the addition of a tail and dorsal turret, and the addition of a Bendix turret to replace the fixed bathtub type that had

graced previous versions. This was found to be disappointing, and was eventually replaced with the Sperry ball turret that became a permanent feature of all future marques.

Boeing's 'G' incarnation of the Fort, was perhaps the most significant of all types built, and of course, numerous 'F' version modifications were carried over, such as the remotely operated Bendix chin turret that was introduced in the late block series of the 'F'. Differences between the 'G' version and the previous main production 'F' type were the positions of the nose cheek guns to accommodate the remote yolk for the Bendix turret operation, and for late block production of the 'G', the introduction of the Cheyenne tail gunner position which offered a reflector gun sight and much improved field of fire. Unlike the early production blocks of the 'G', the later production blocks introduced staggered waist gun positions for the flexible-mount .50-cal machine guns.

The B-17G was powered by 4 x Wright R-1820-97 "Cyclone" 1200hp turbocharged radial engines that were constantly uprated over the service life of the B-17, and it also carried 13 x .50cal M2 Browning machine guns. A typical long-range mission would see the B-17G carry around 4,500lbs of bombs. Wingspan was 103ft 9in, with a length of 74ft 4in. A crew of 10 was typically carried by all variants of the B-17G.

-  BE CAREFUL
-  REMOVE
-  GLUE TOGETHER
-  PLEASE WAIT FOR A FEW MINUTES UNTIL DRY
-  MAKE 2 PIECES
-  DRILL HOLE
-  DO NOT GLUE
-  INSTANT GLUE FOR METAL
-  BEND
-  FILL HOLE
-  SEQUENCE OF WORK
-  OPTIONAL
-  USED COLOUR
-  APPLY DECAL
-  MARKING OPTION

CAUTION
When using both glue and paint, do not use these near an open flame, due to the flammable properties of these items.
The symbols provided, such as 'X', refer to the basic colours of parts, although a more comprehensive list is supplied for your use for Tamiya, Mr Hobby and AK-Interactive codes.
When removing parts from sprues, take extreme care. Consider correct tools such as Xuron Sprue Cutters
Please check the symbology on the left and familiarise yourself before building this model kit.

In cooperation with: 
www.ak-interactive.com

 Large Scale Modeller
www.largescalemodeller.com

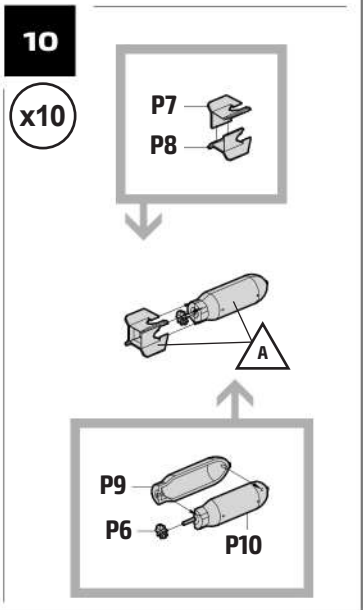
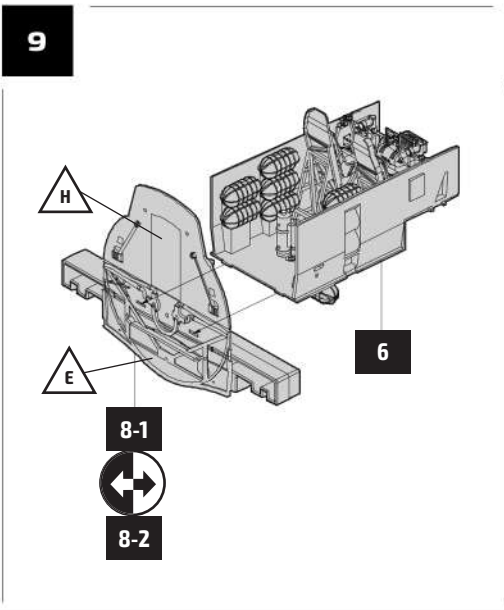
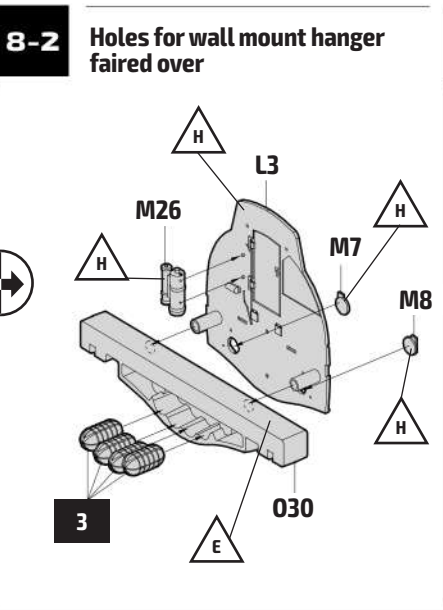
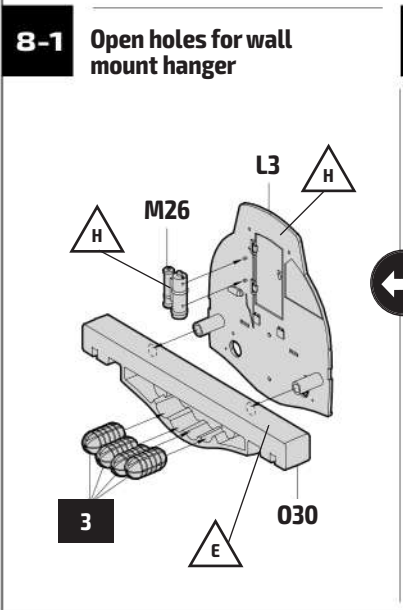
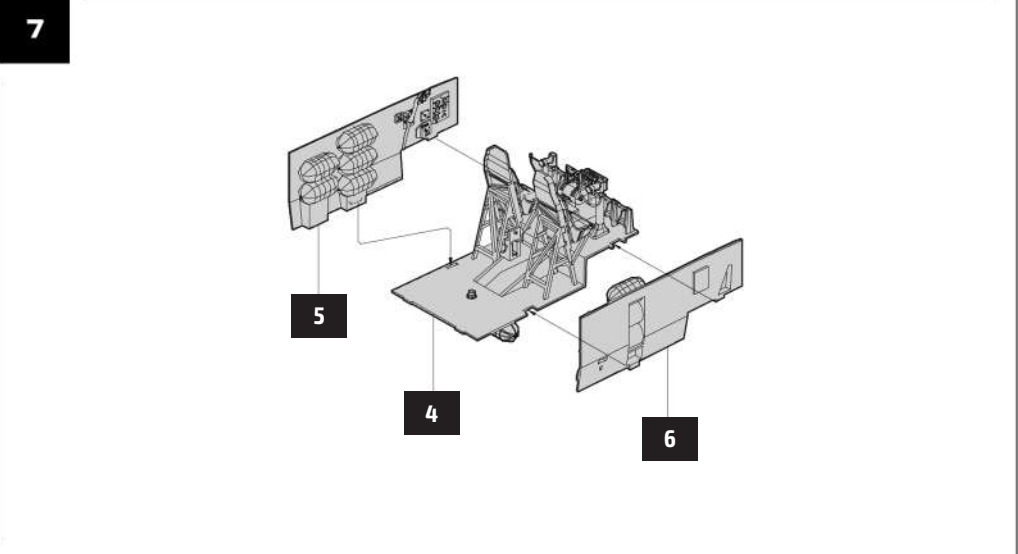
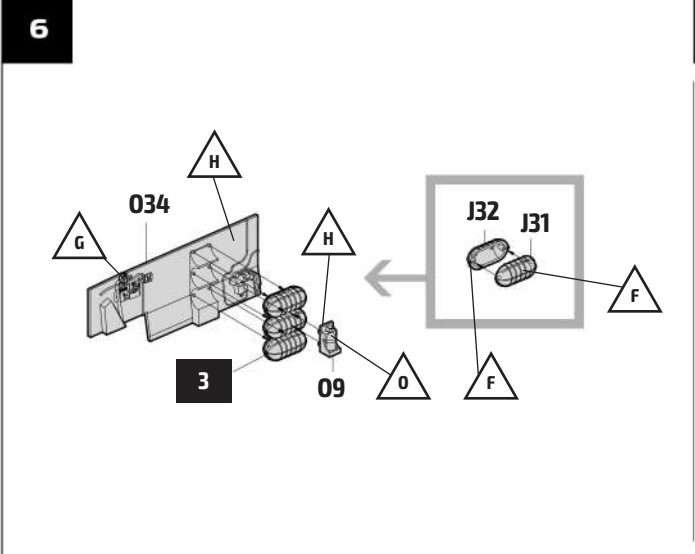
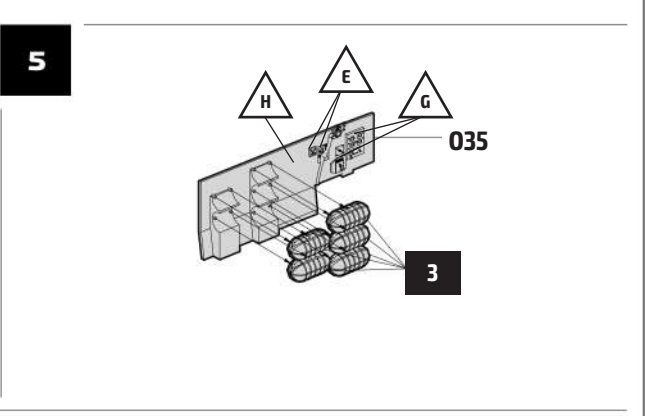
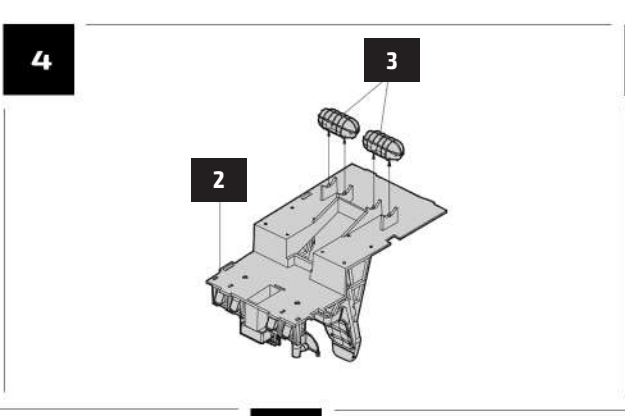
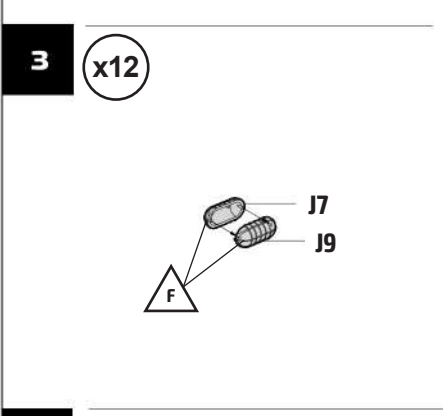
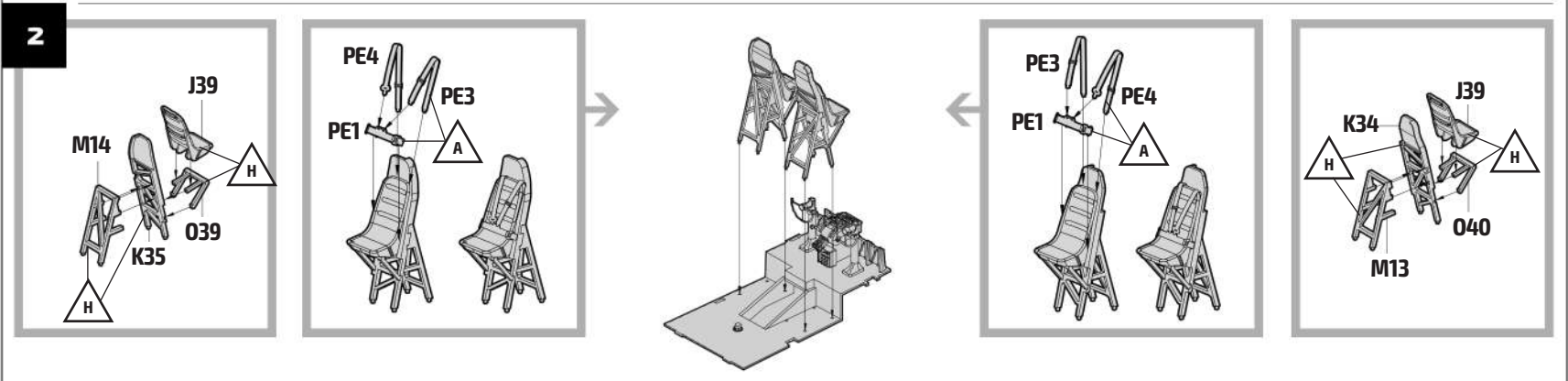
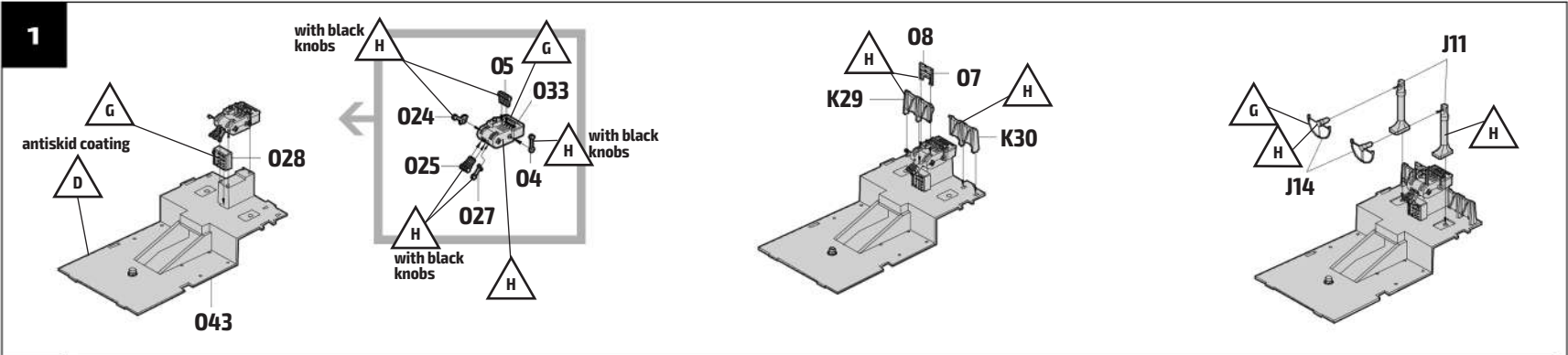

11

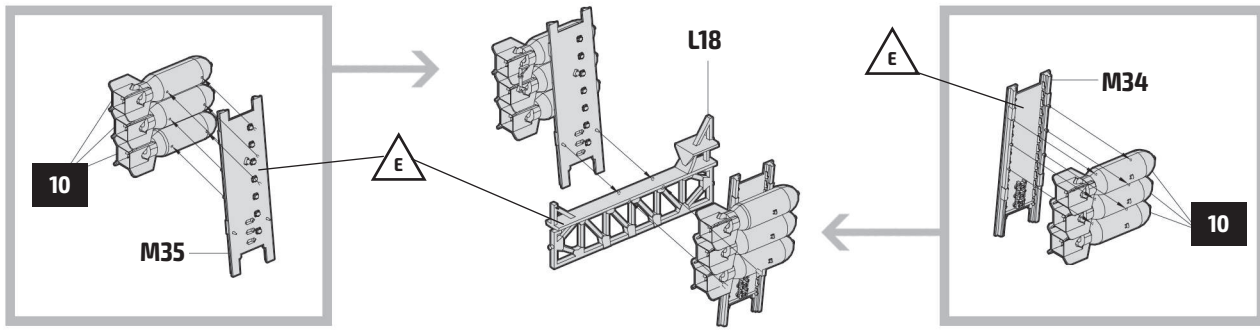

12

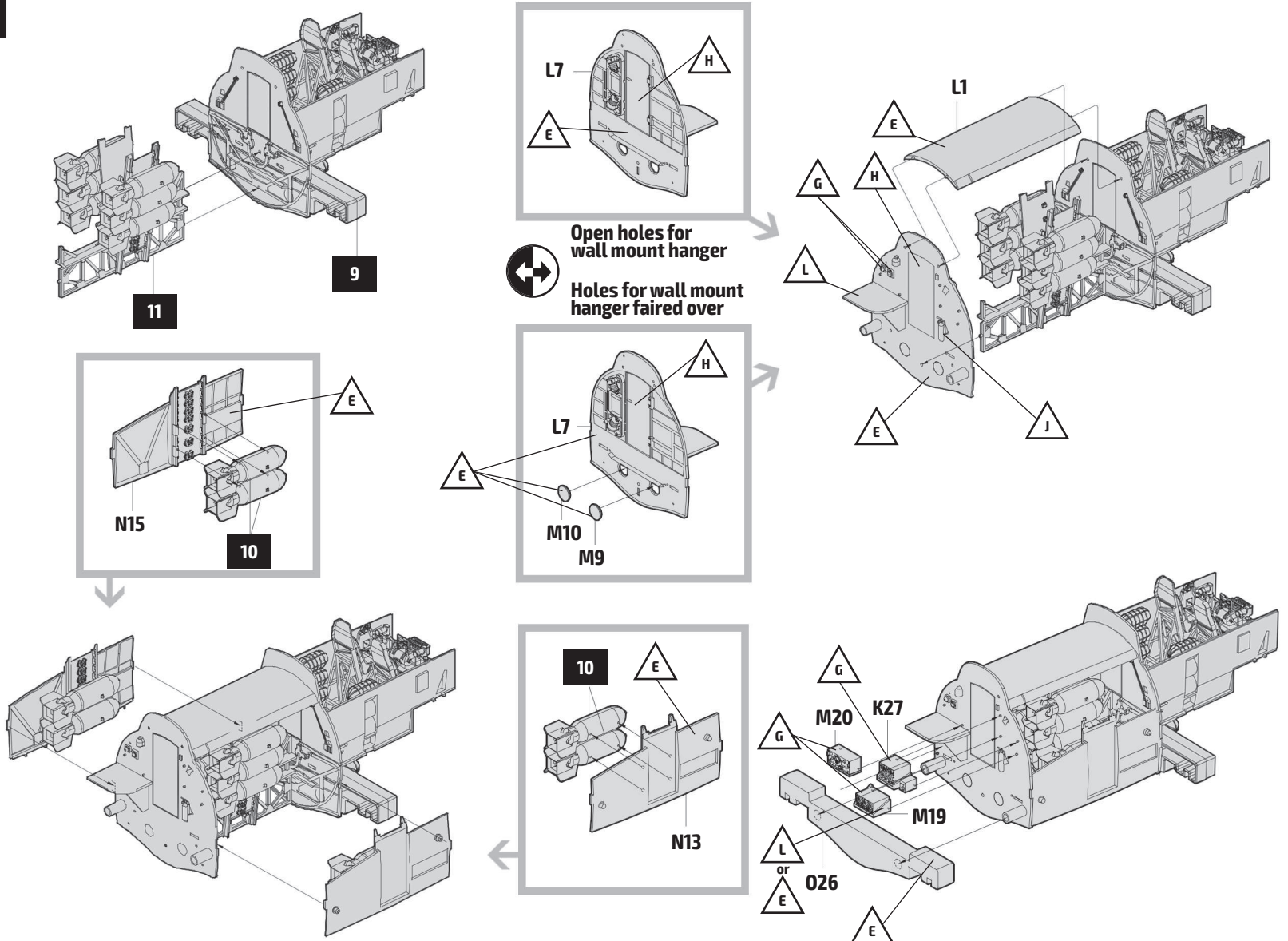

13

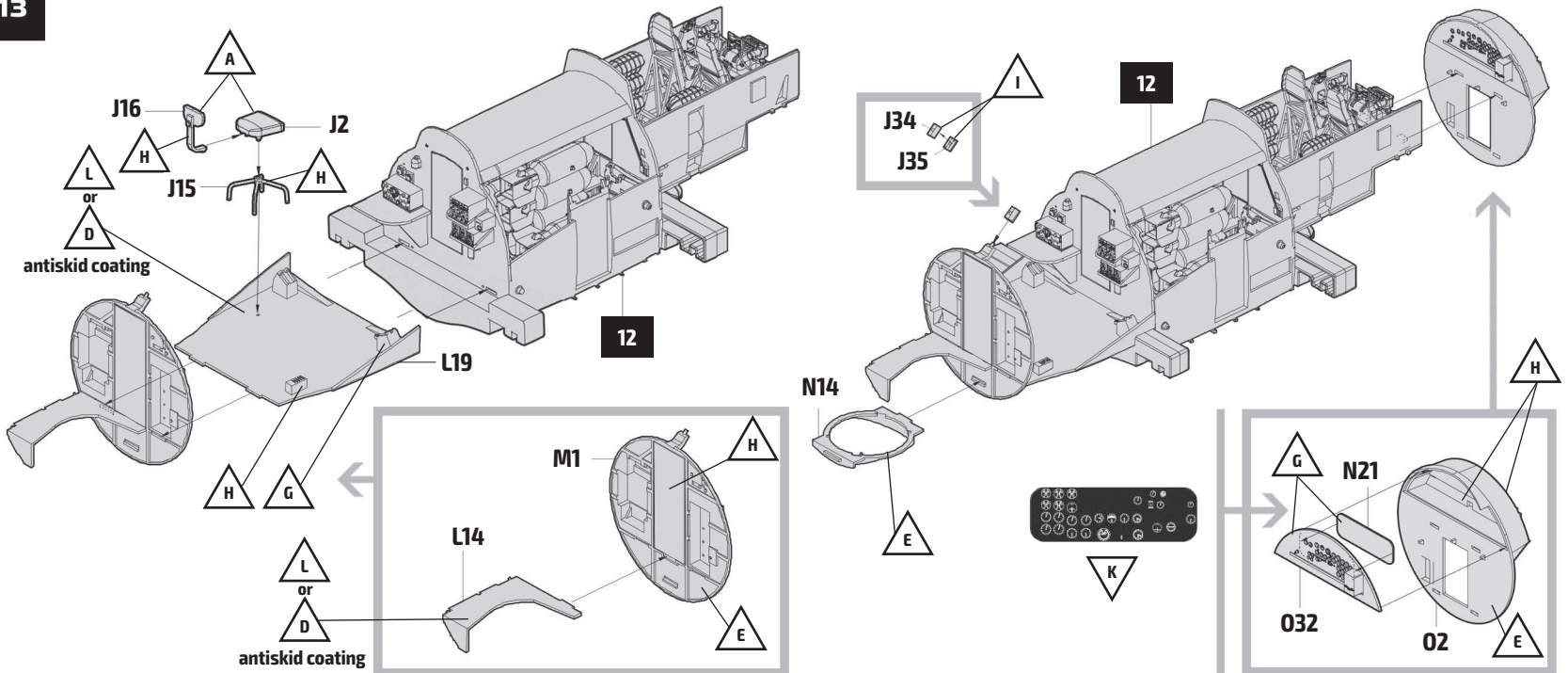

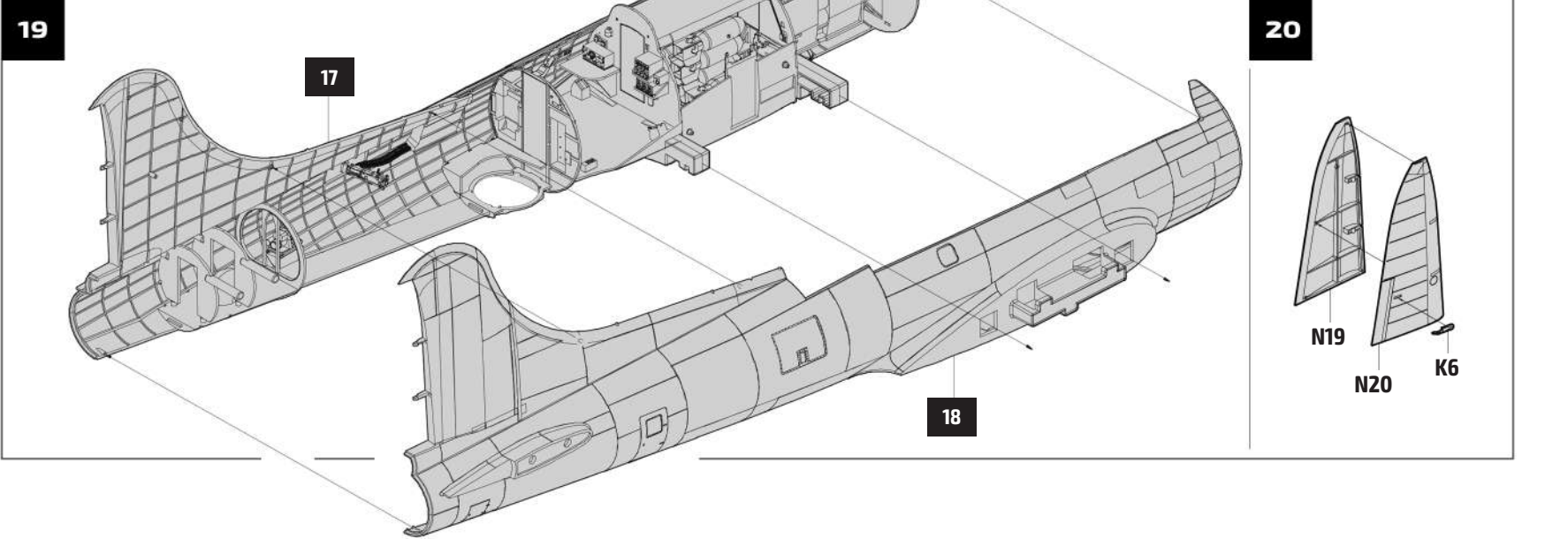
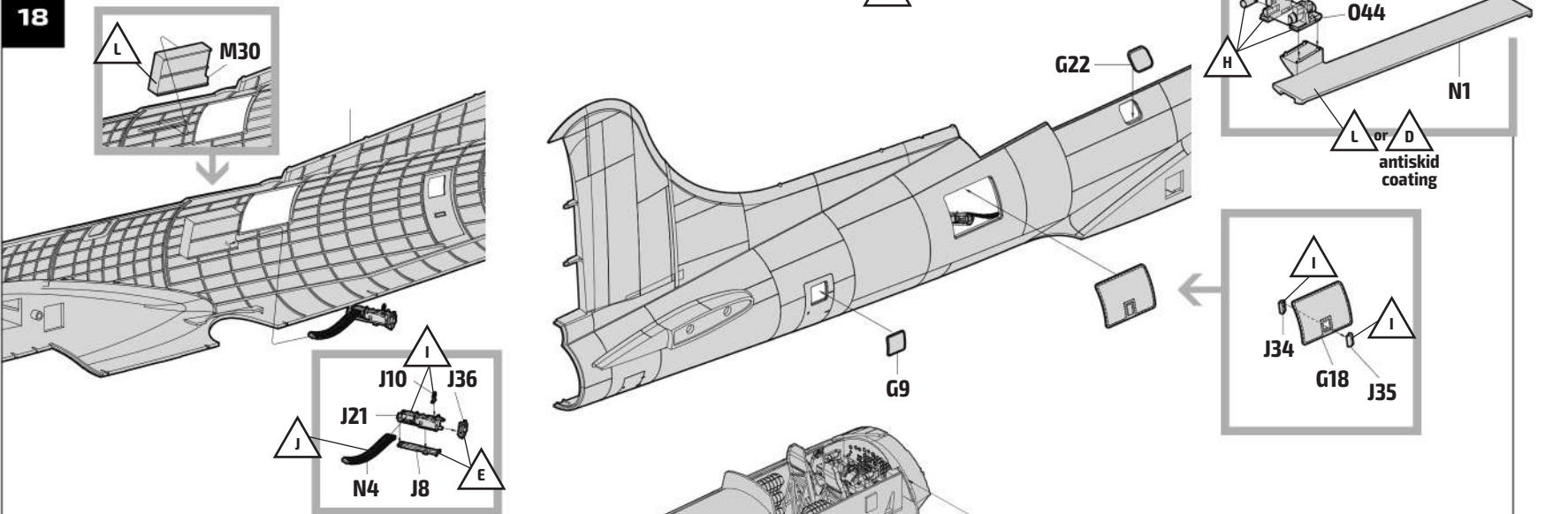
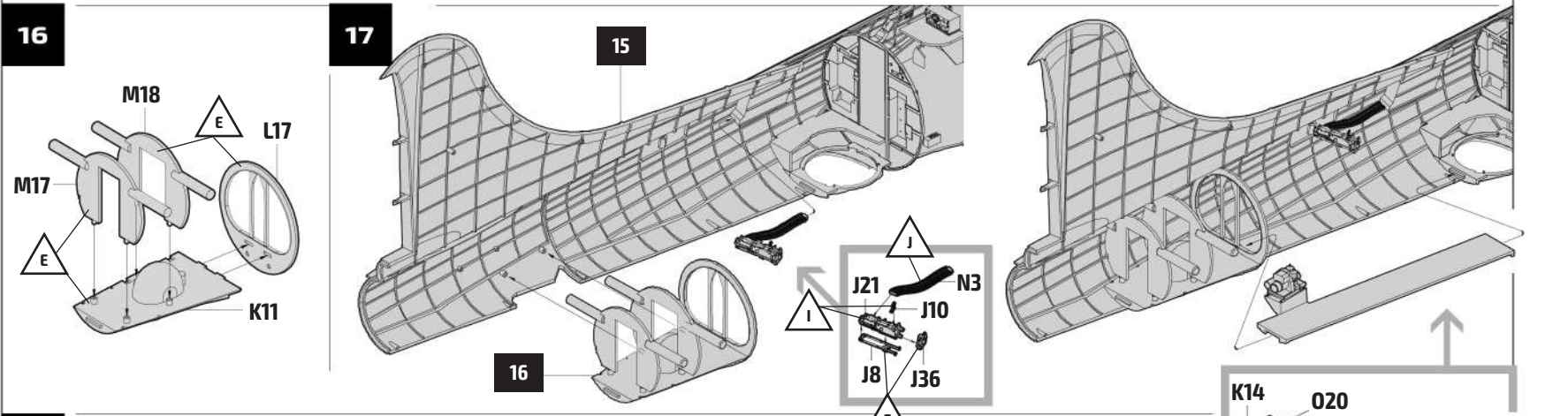
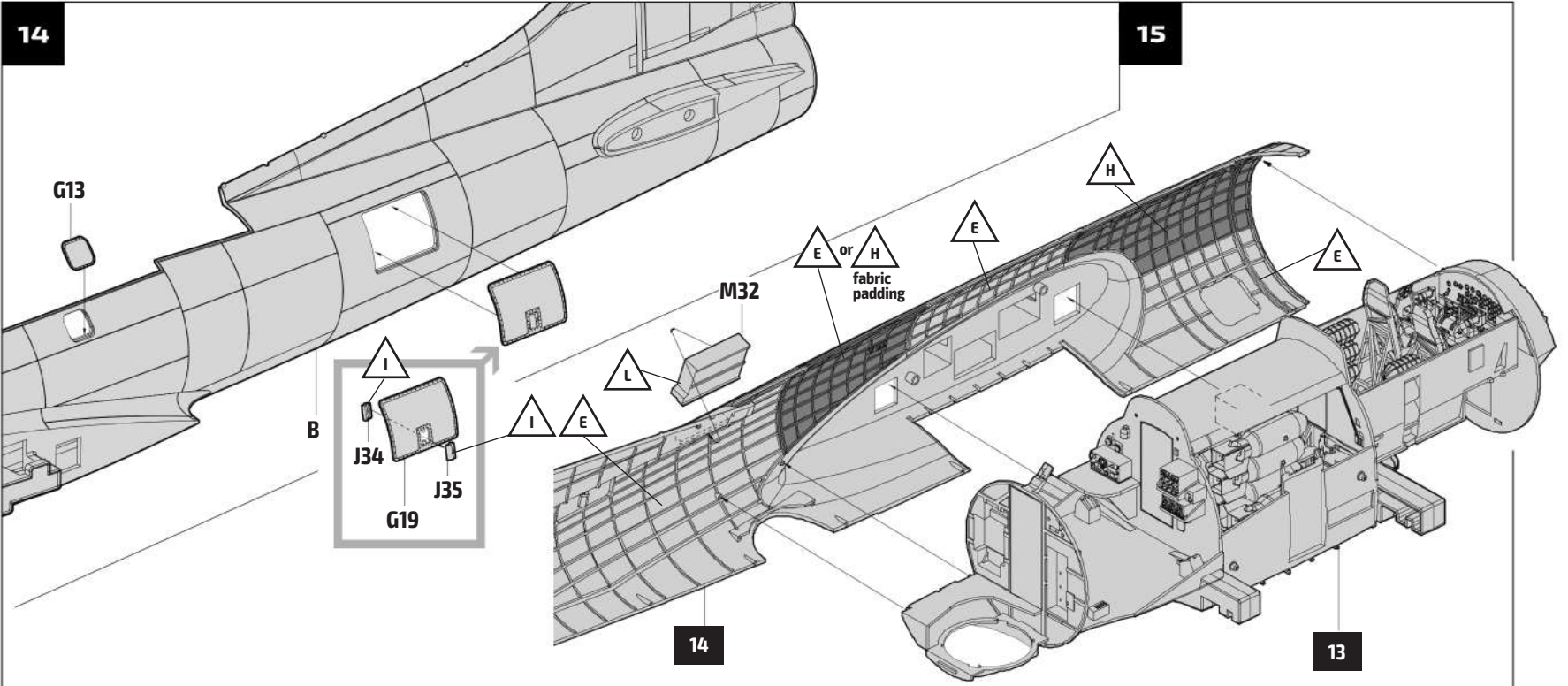

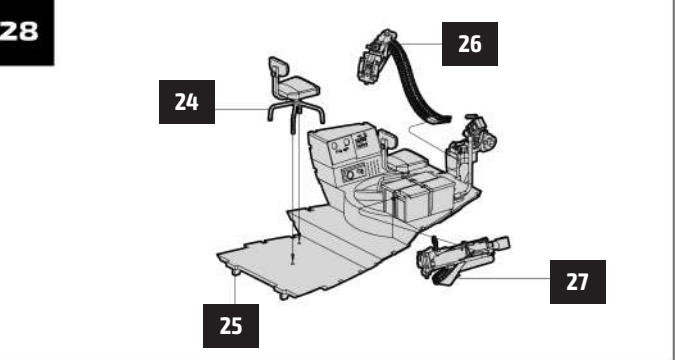
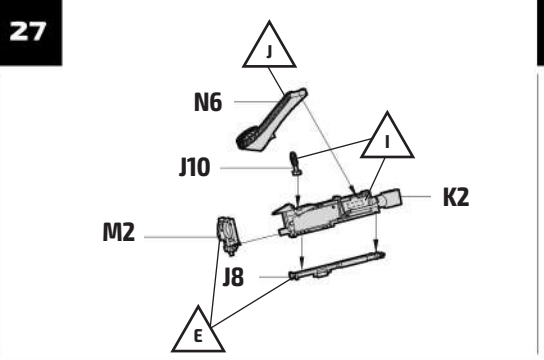
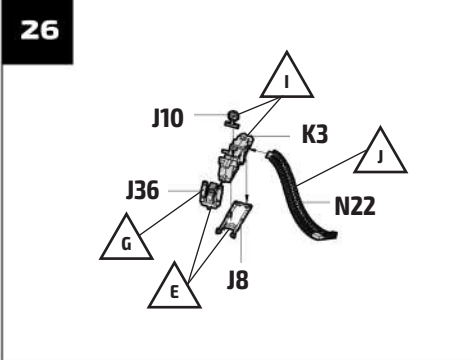
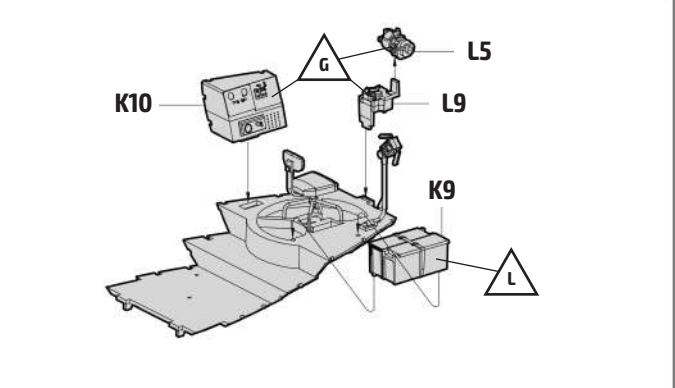
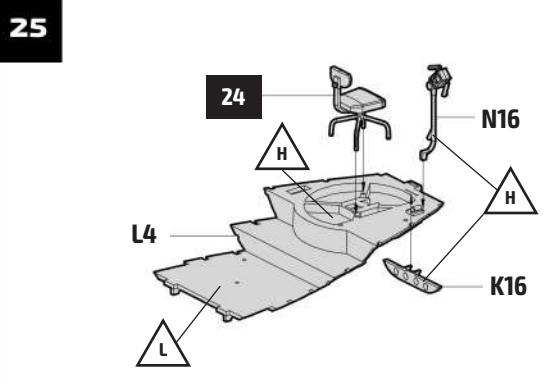
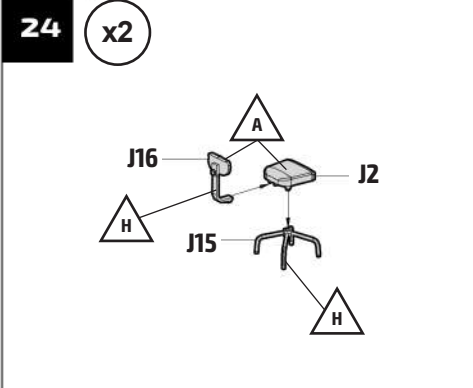
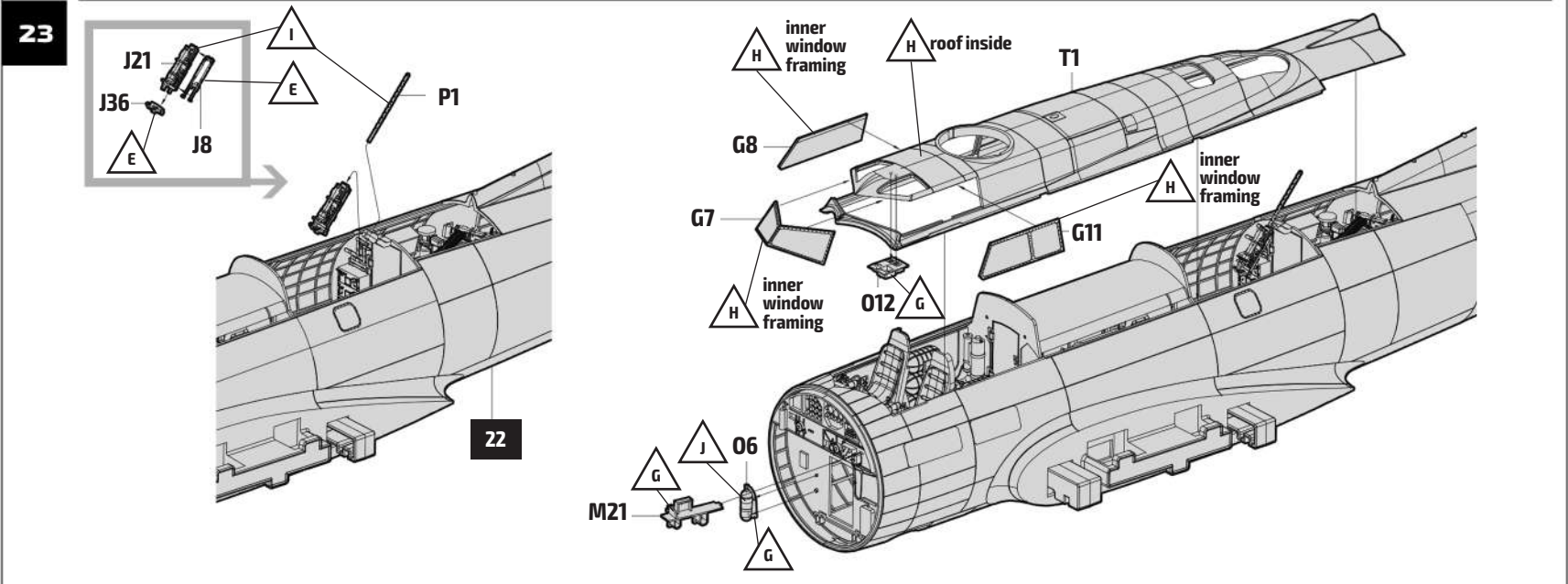
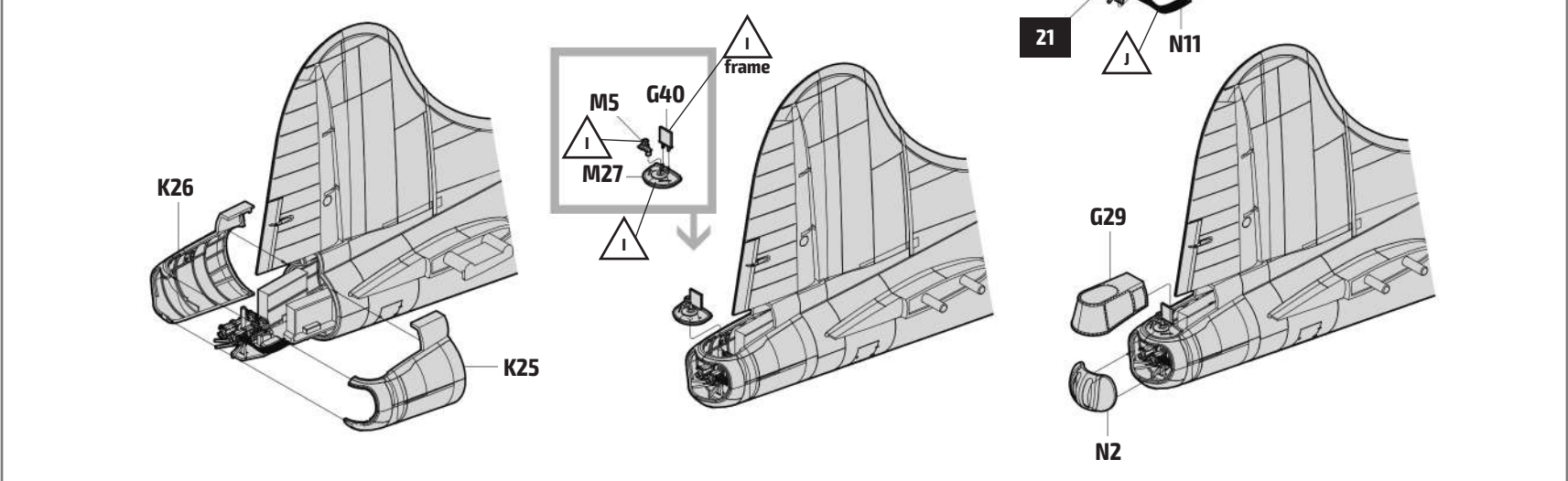
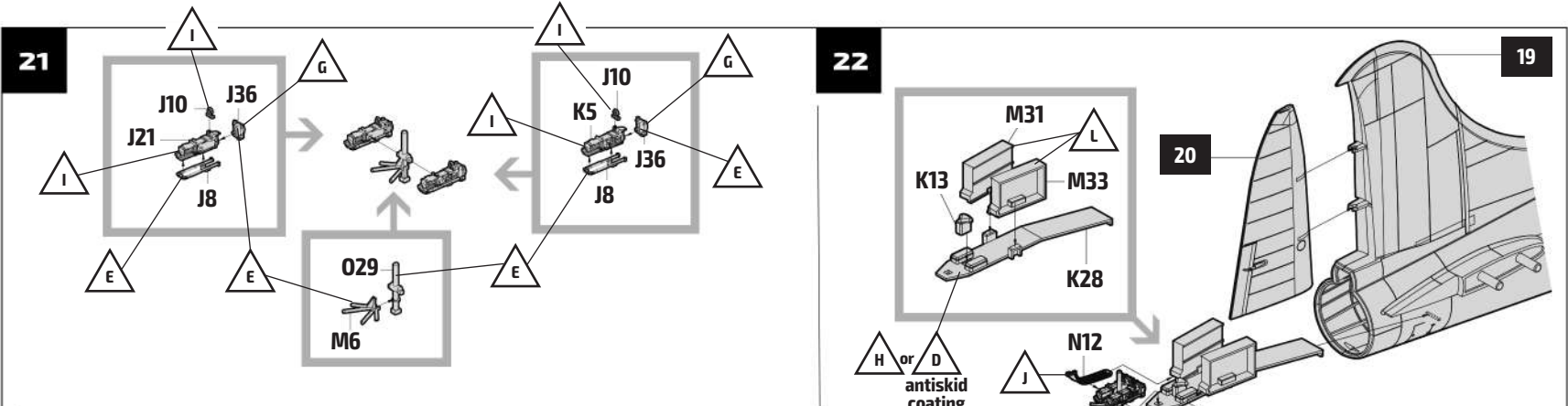

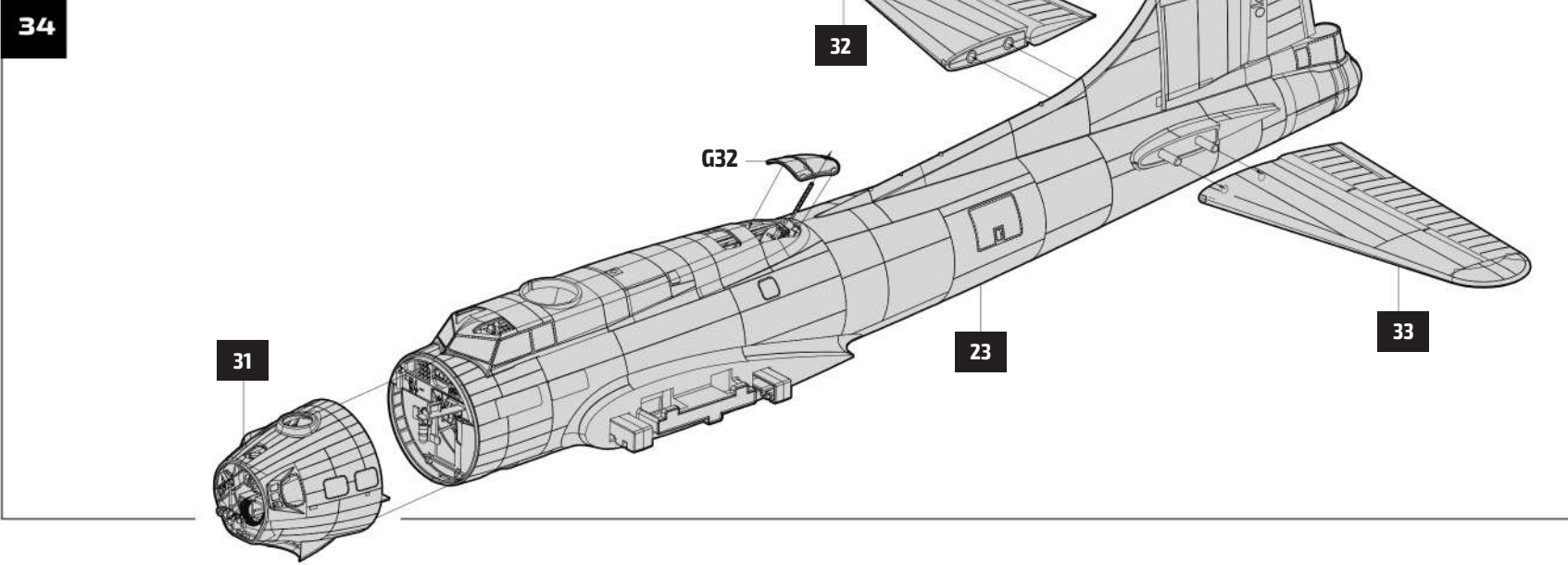
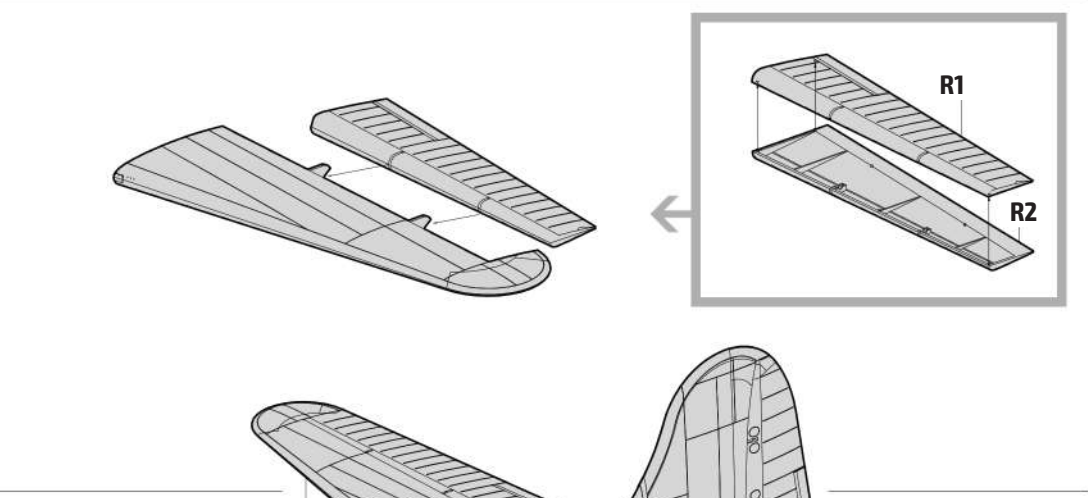
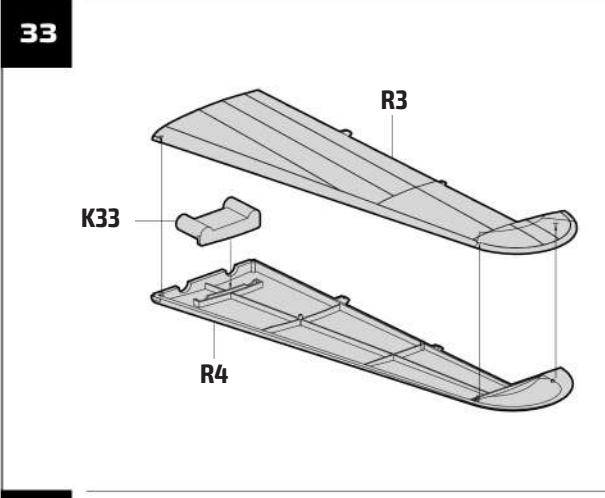
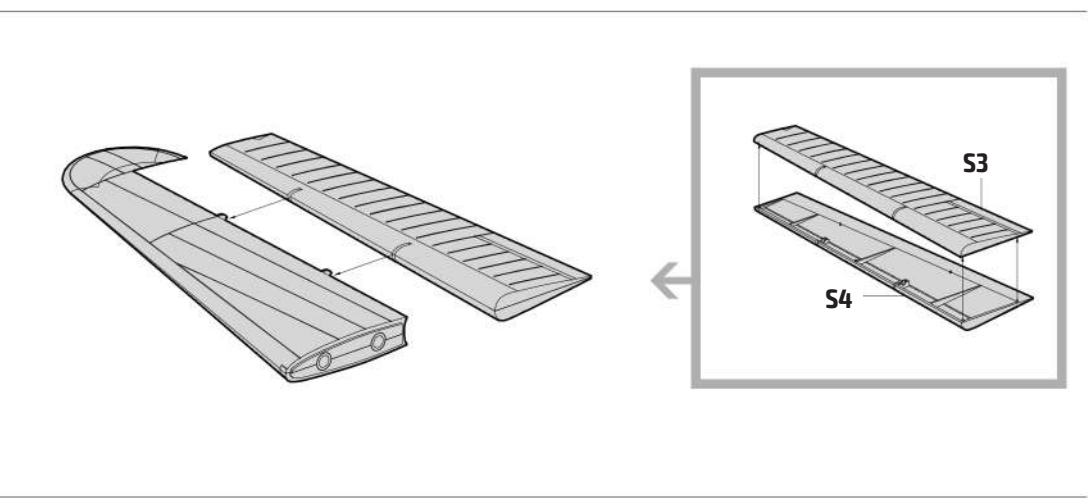
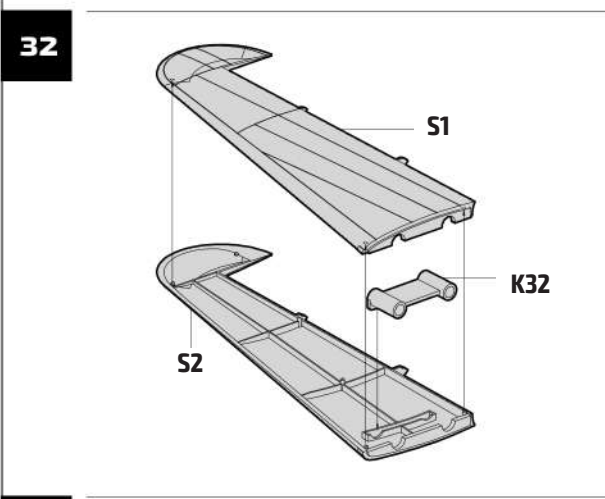
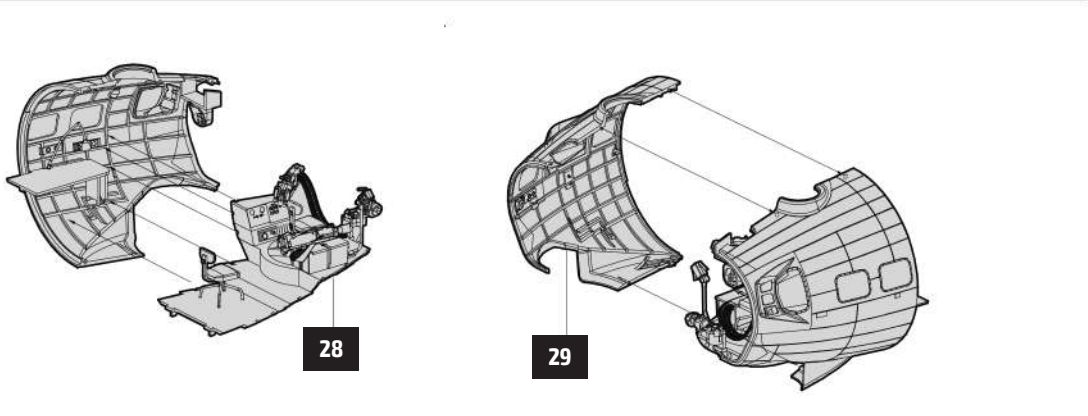
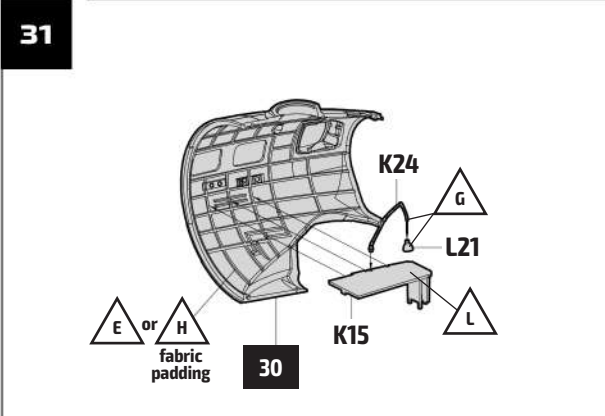
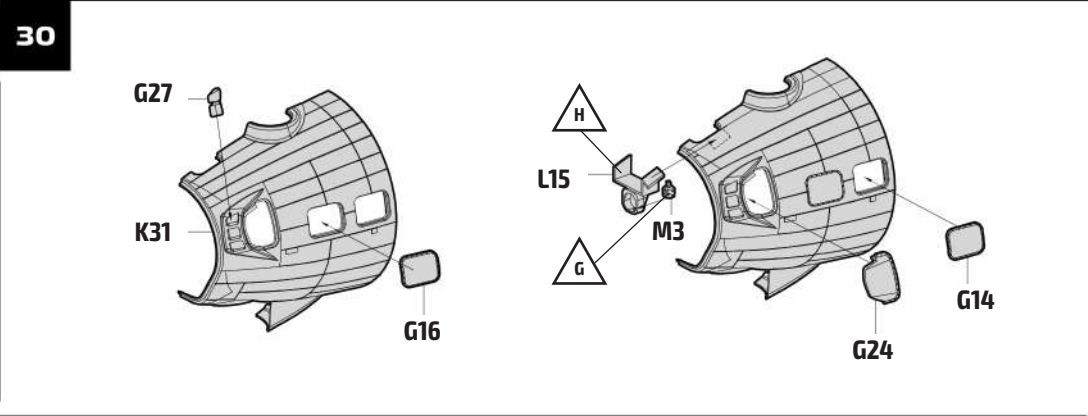
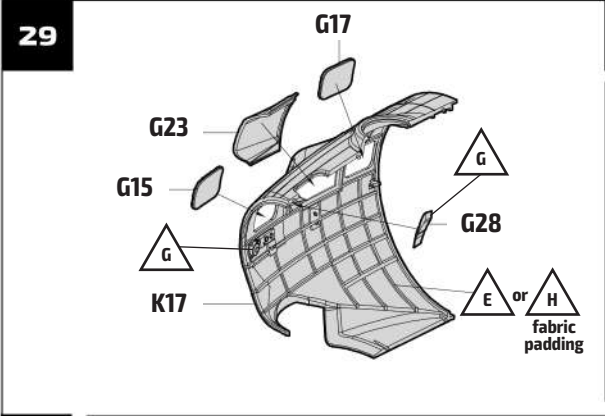

35

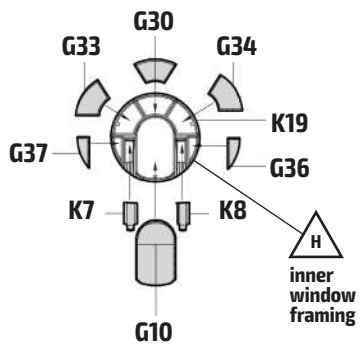

36

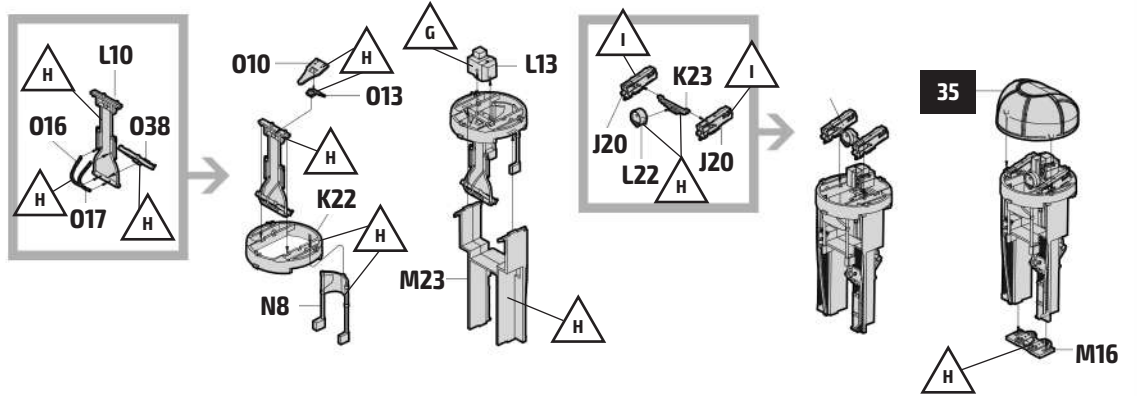

37

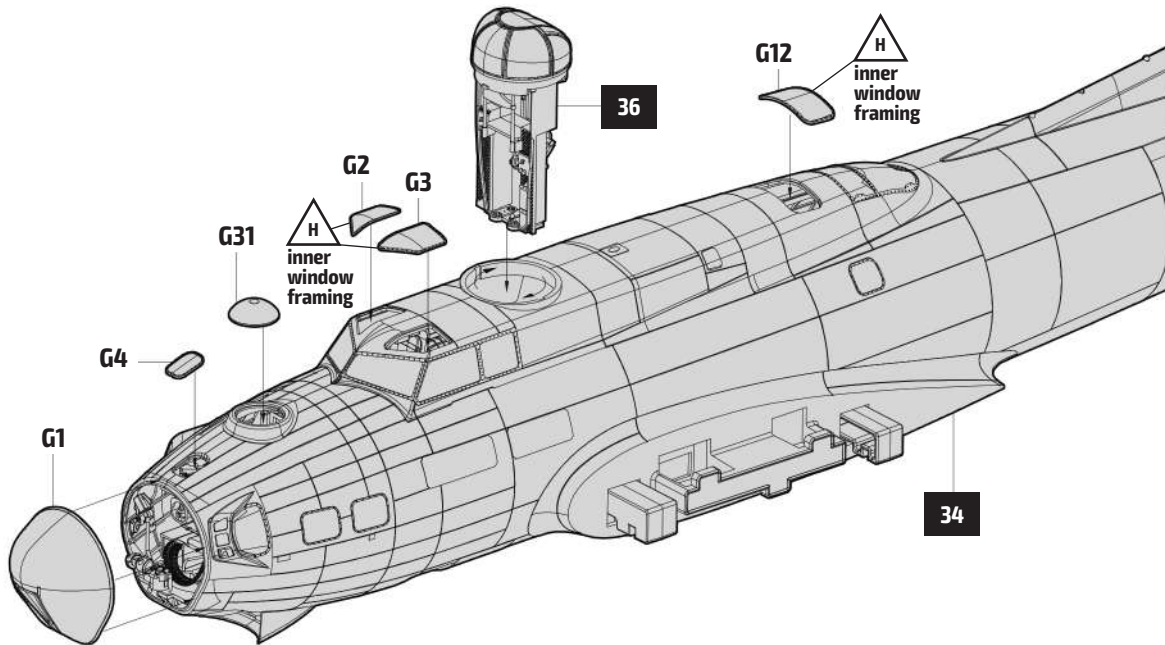

38

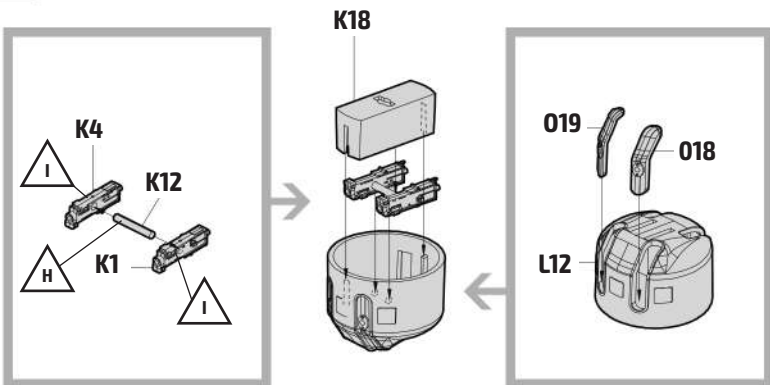

39-1

Tailwheel in extended position

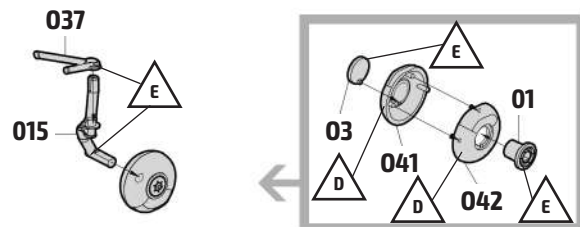

39-2

Tailwheel in retracted position

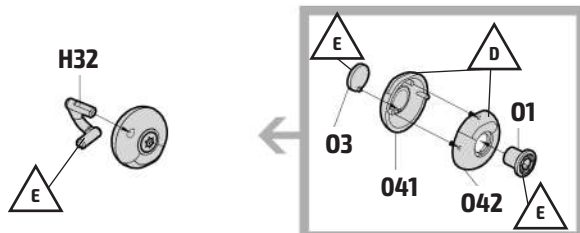

40

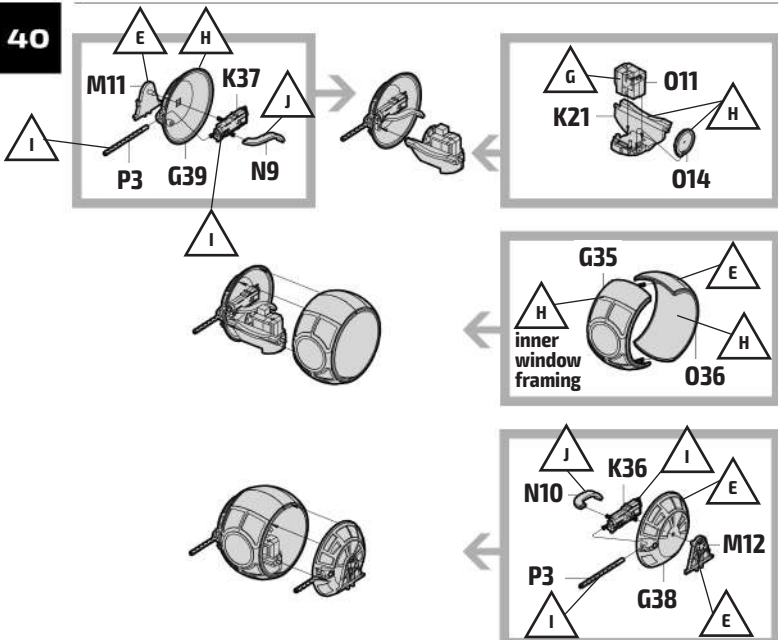

41

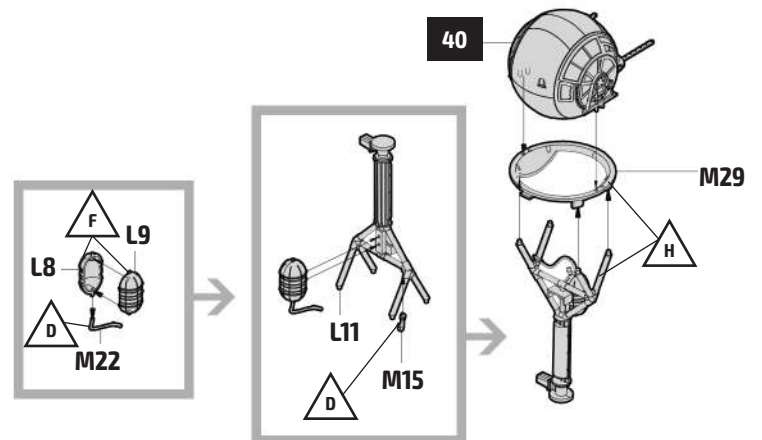

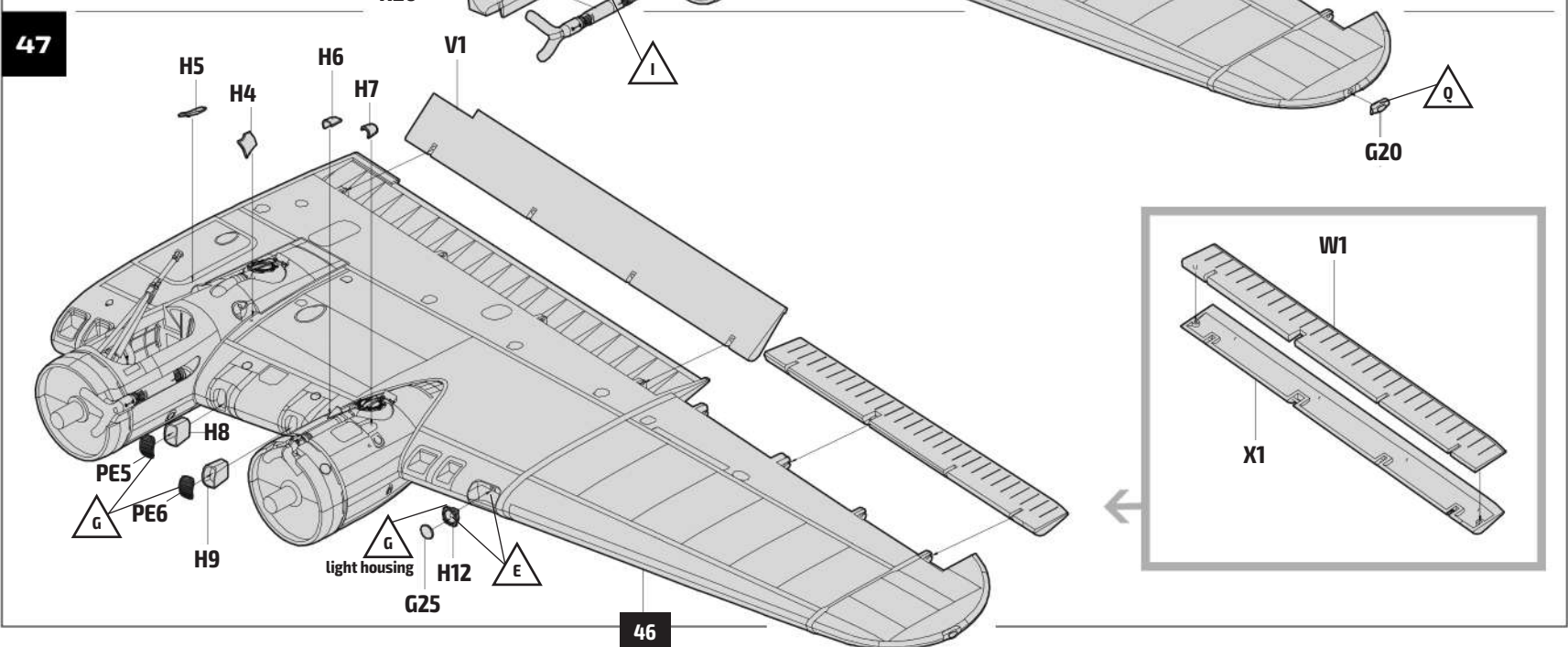
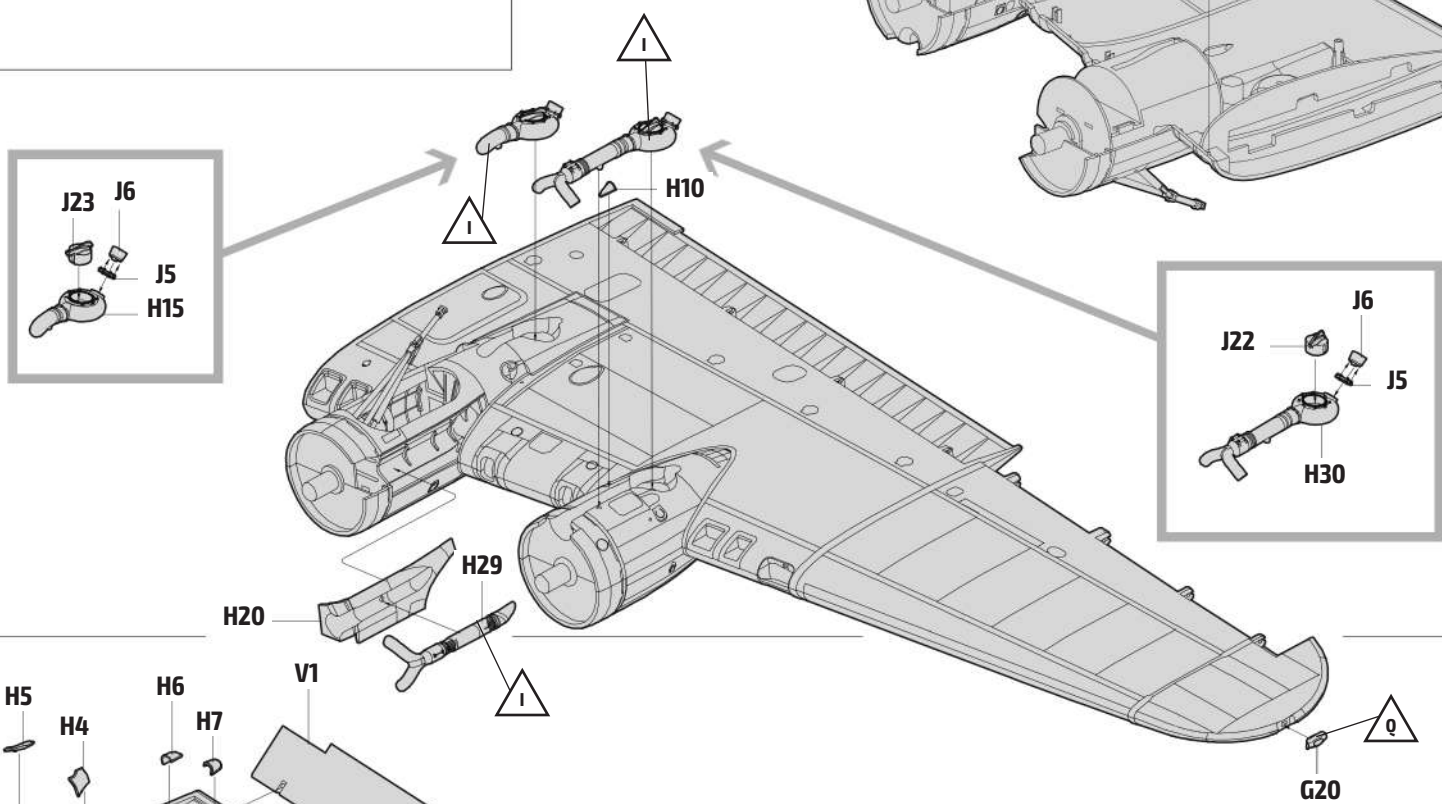
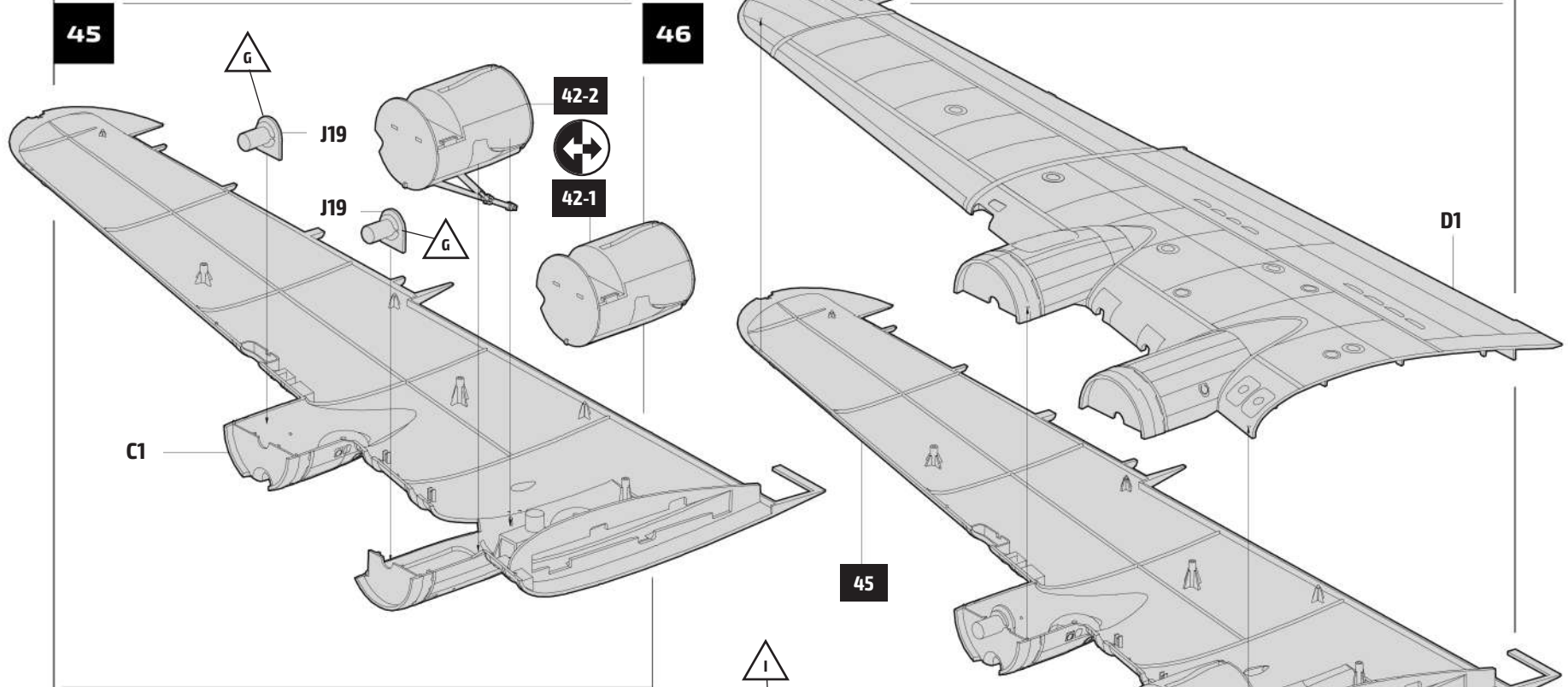
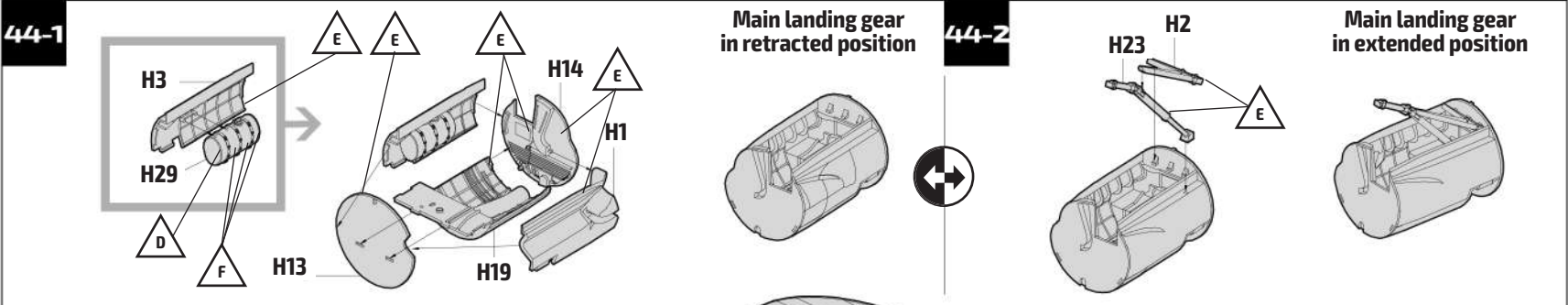

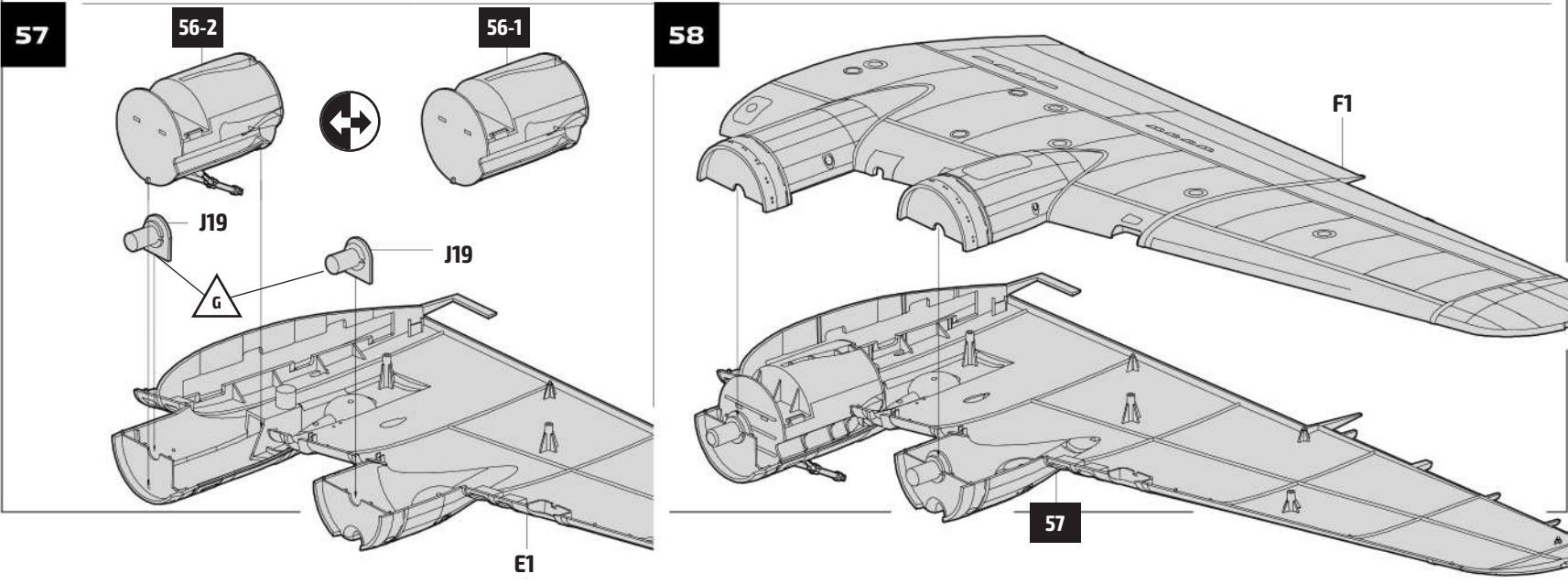
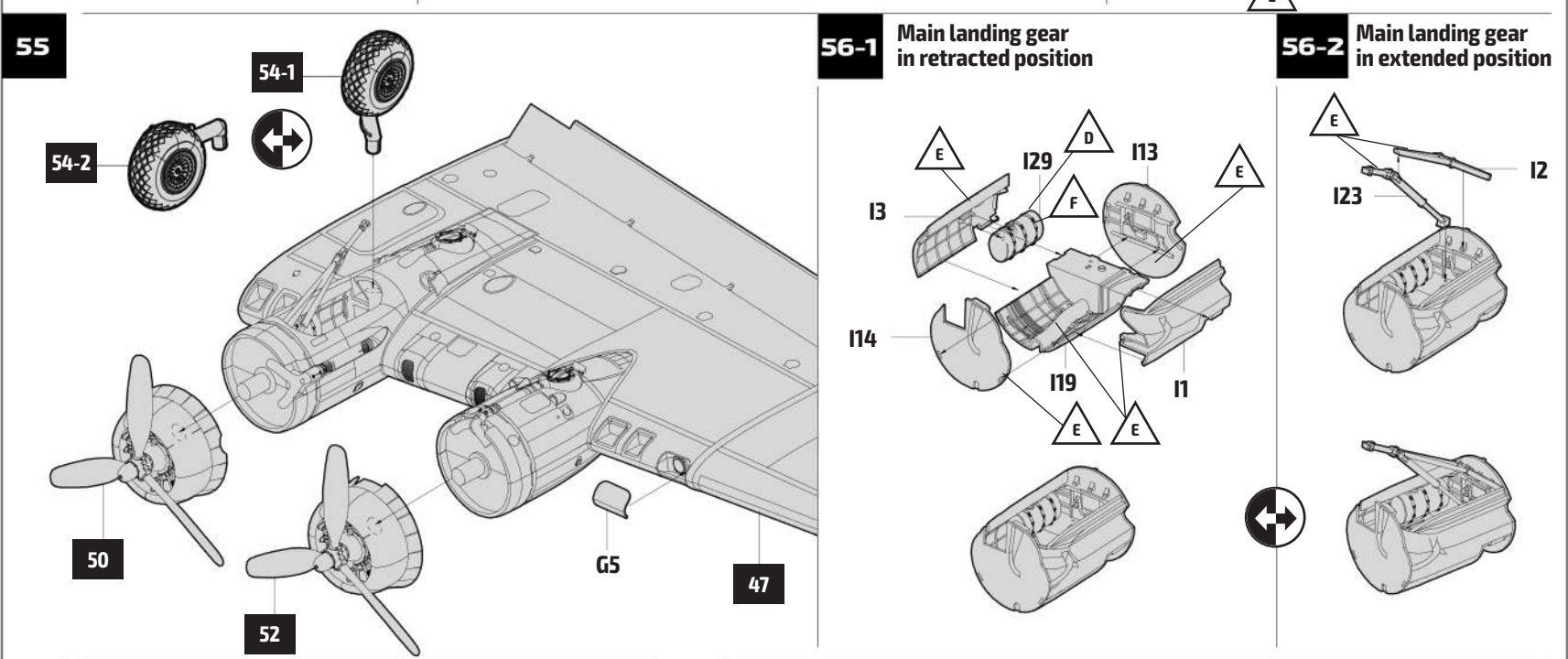
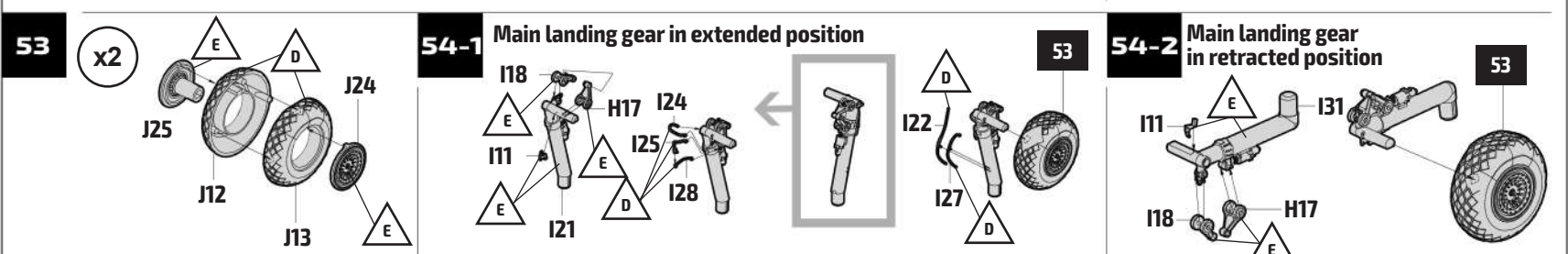
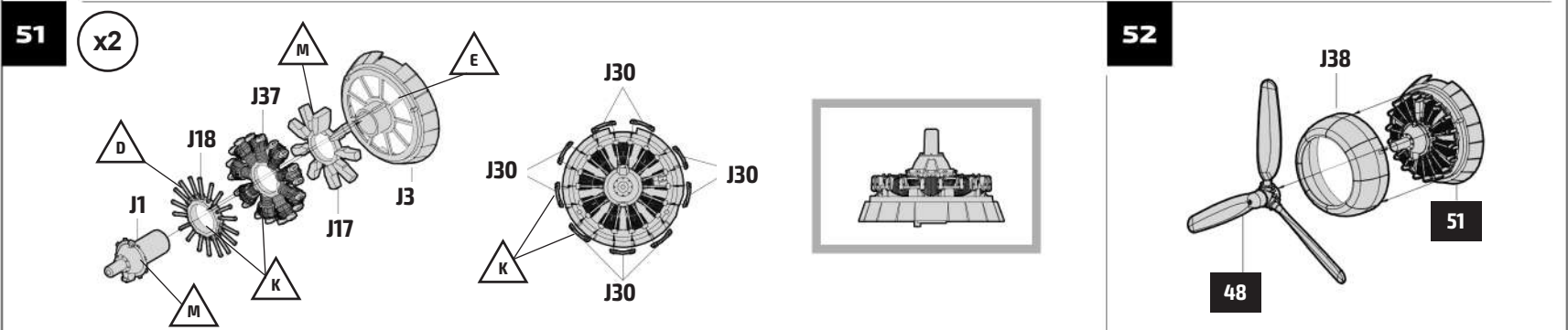
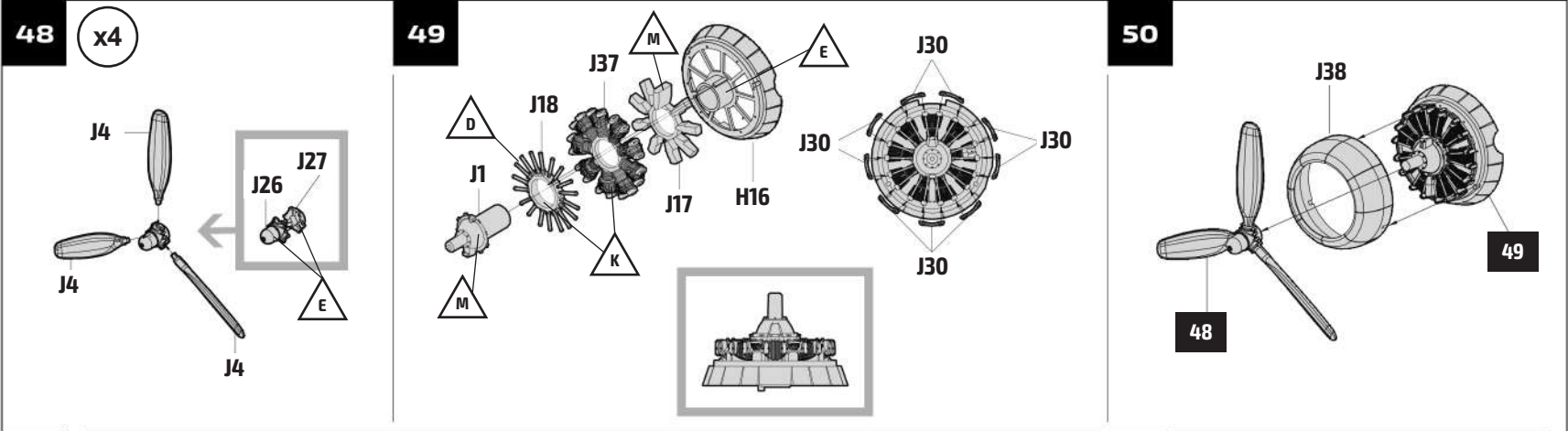

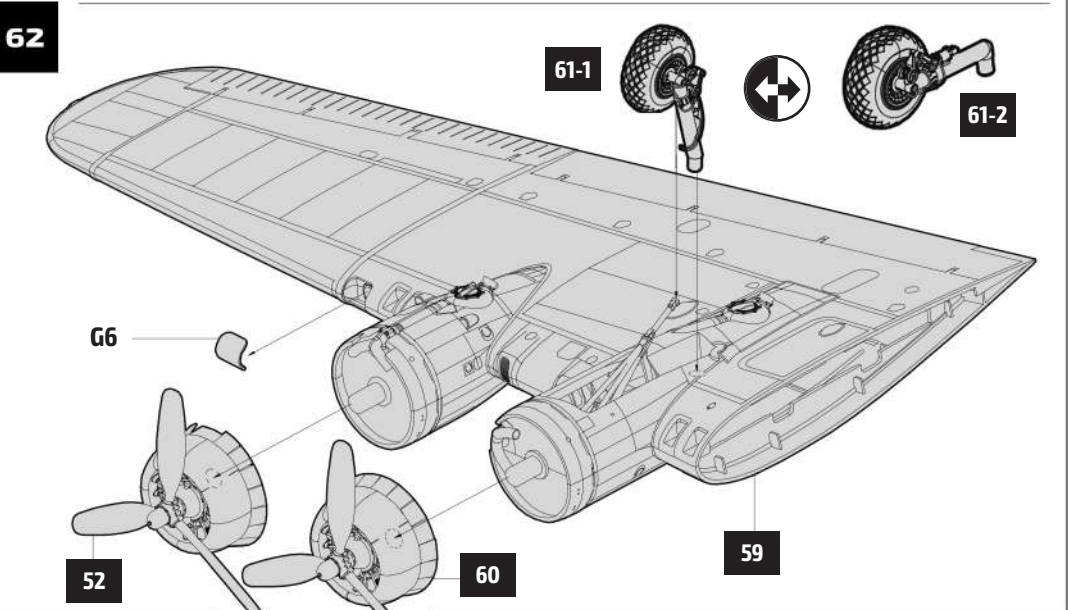
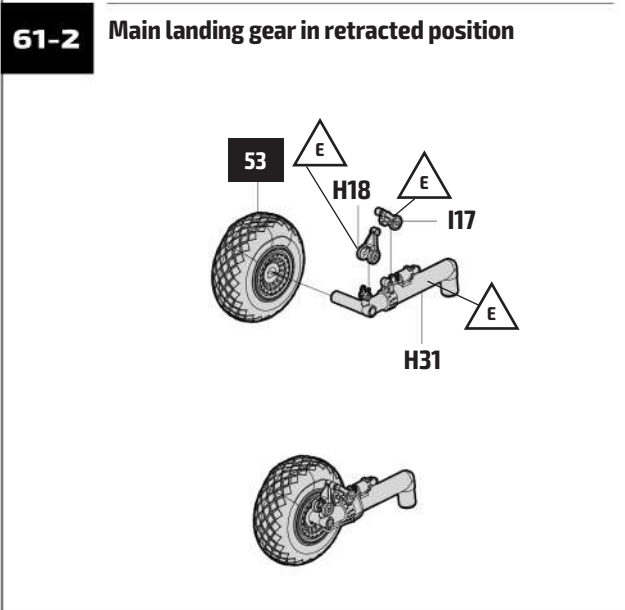
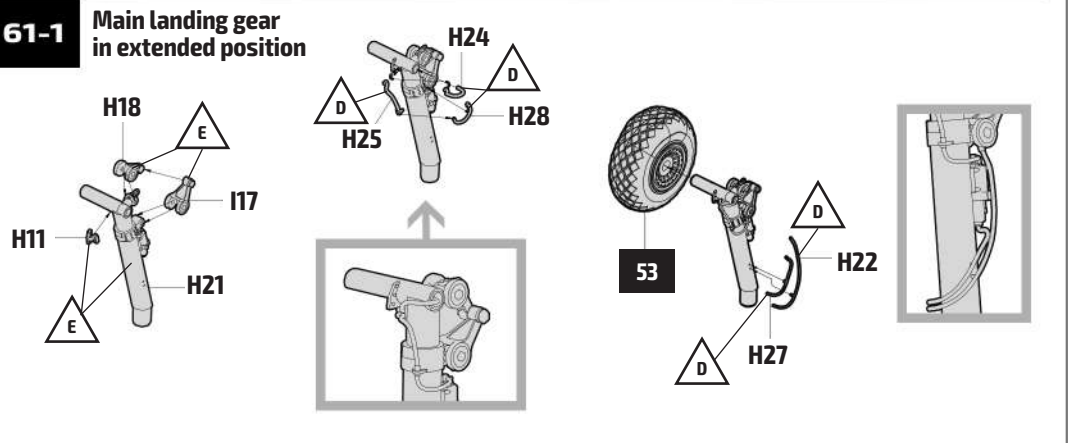
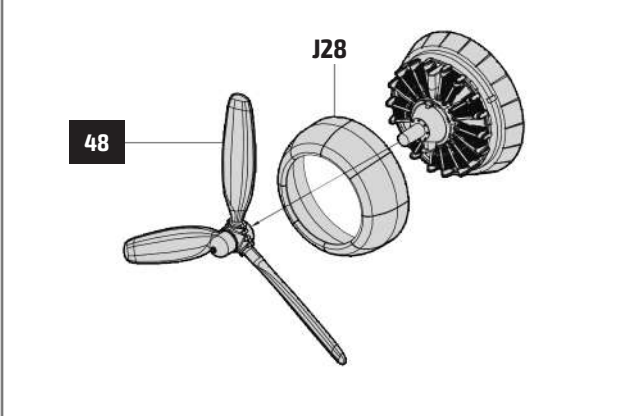
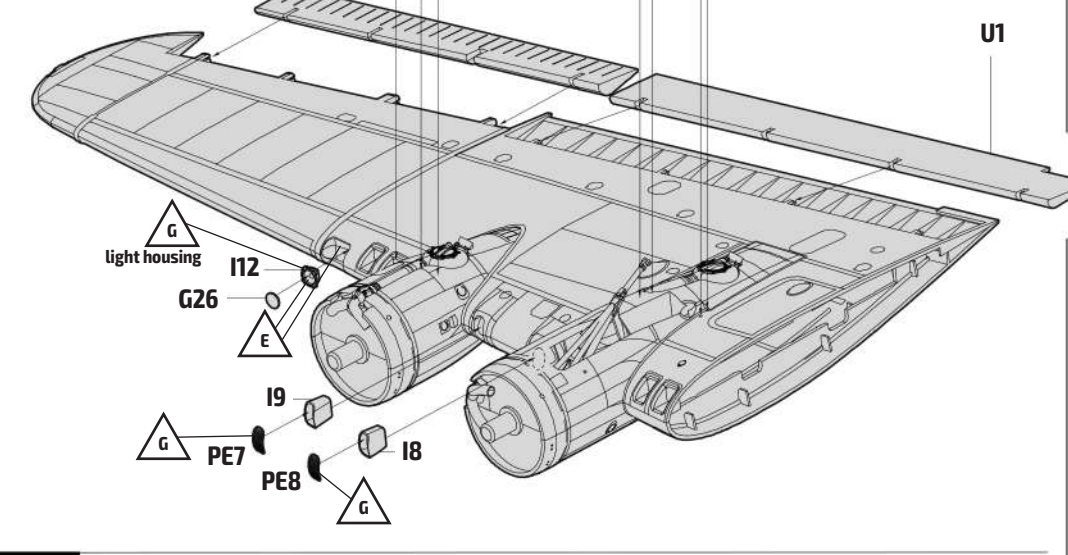
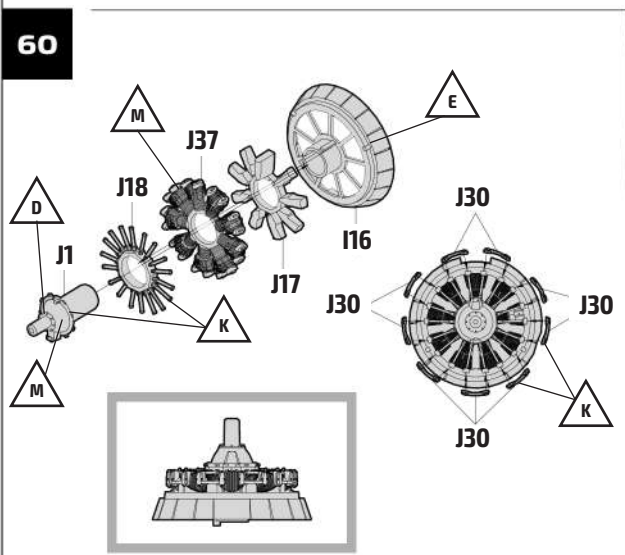
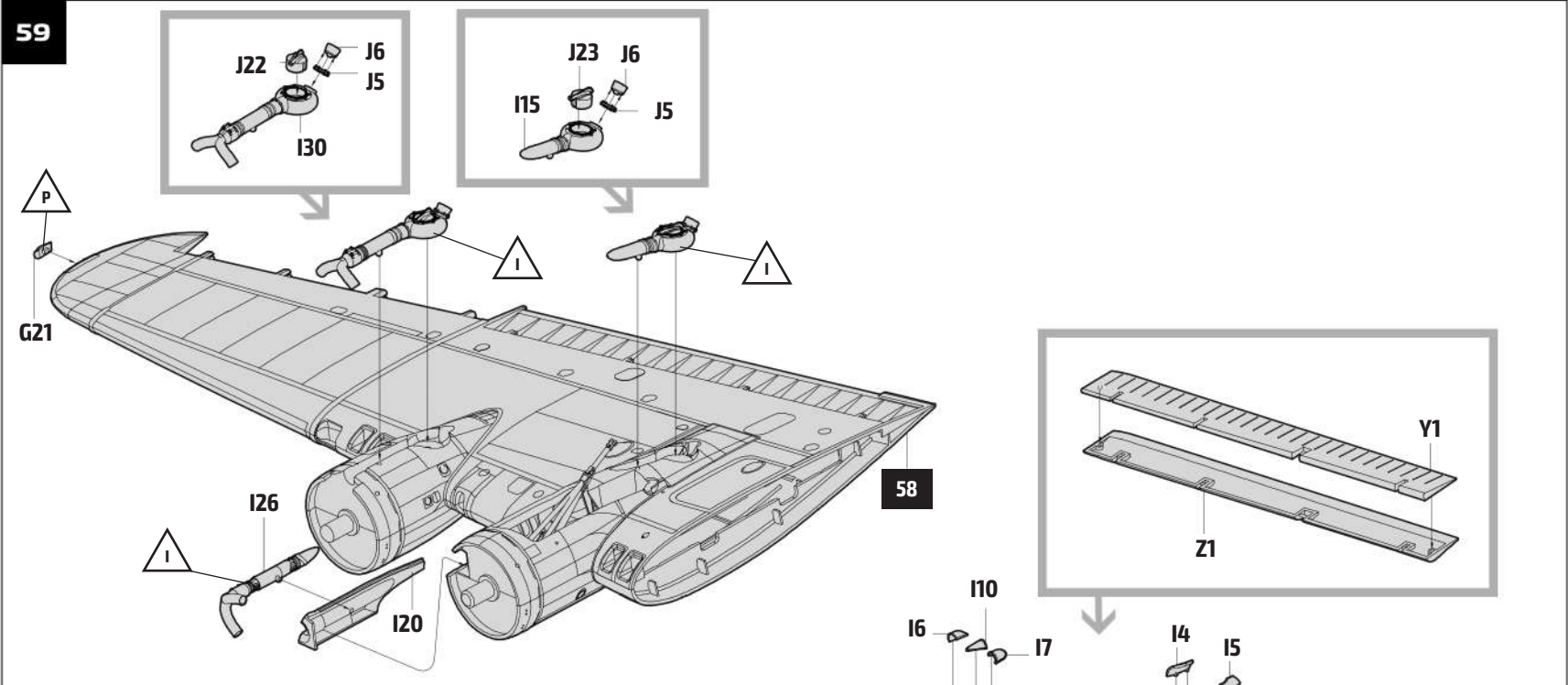

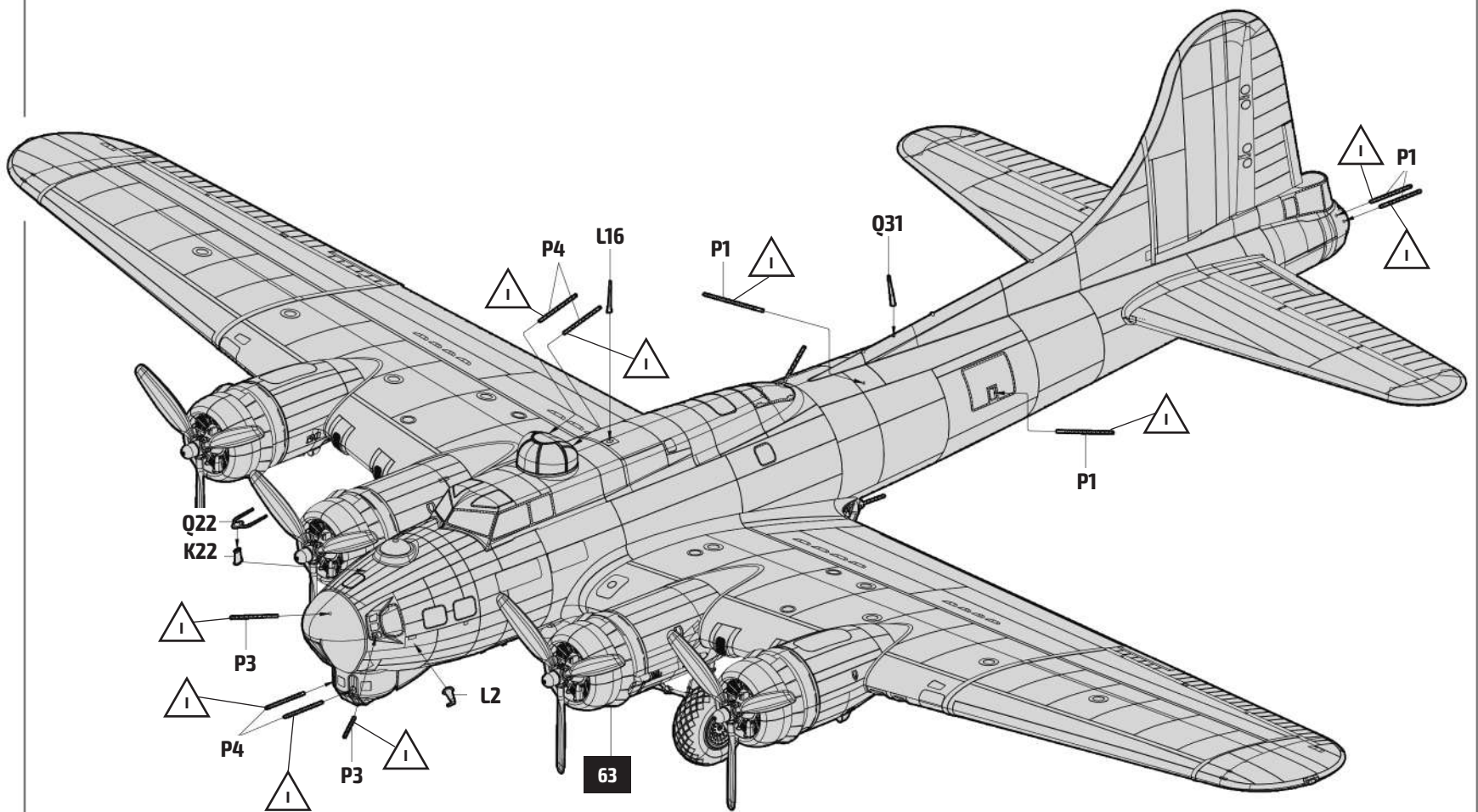
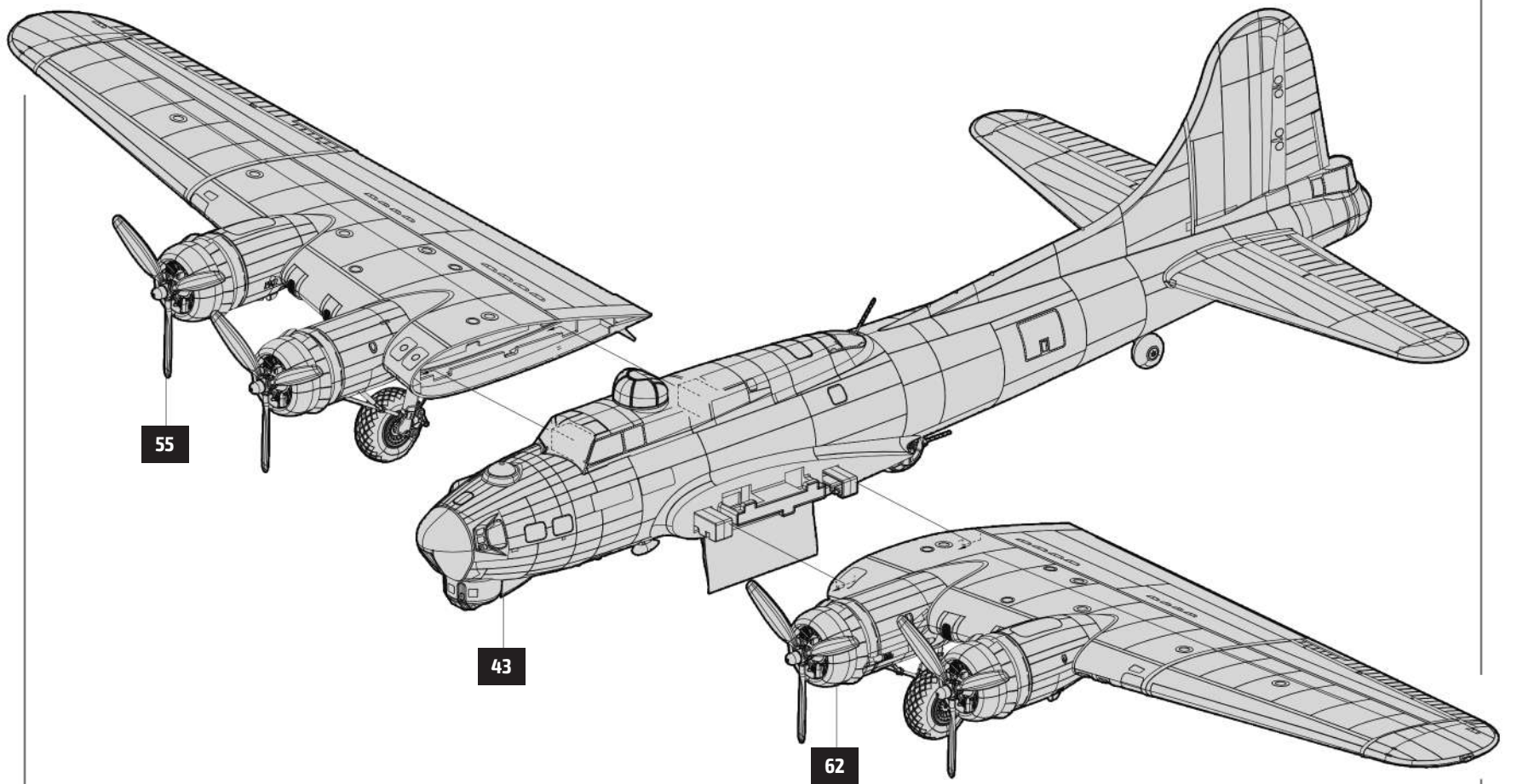

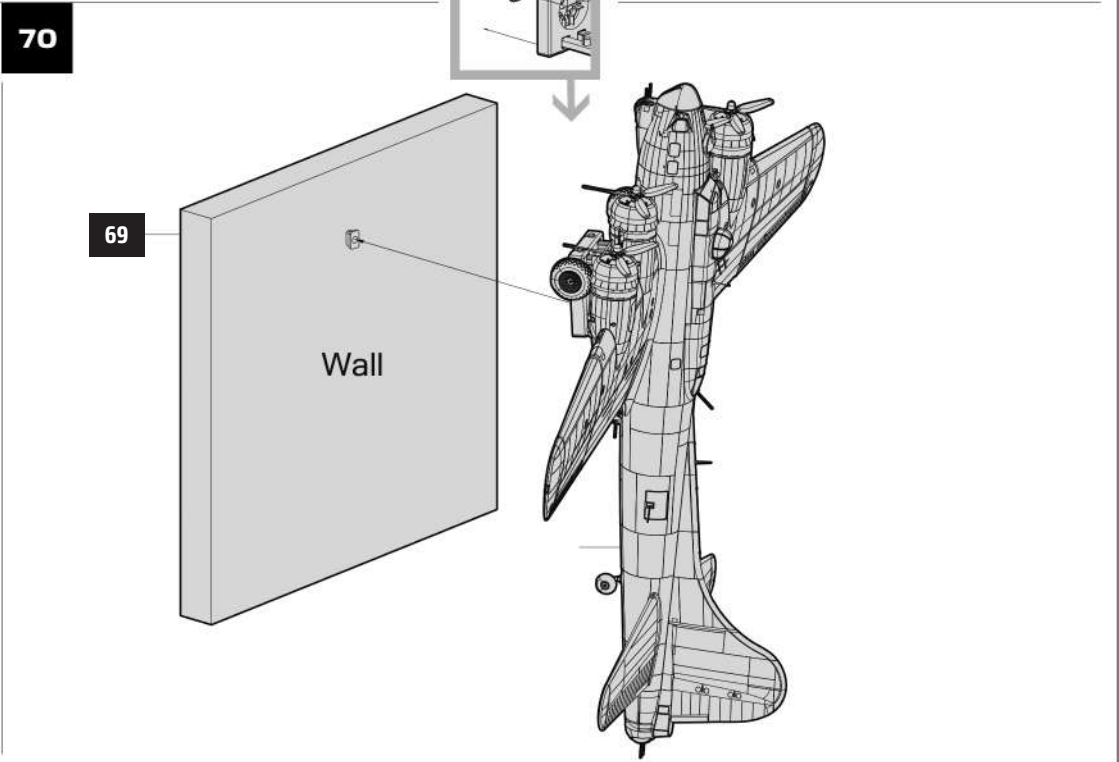
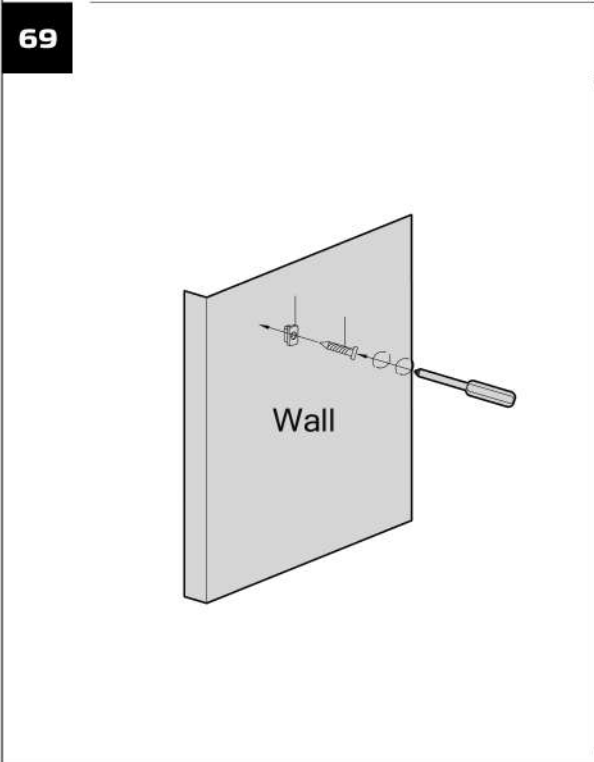
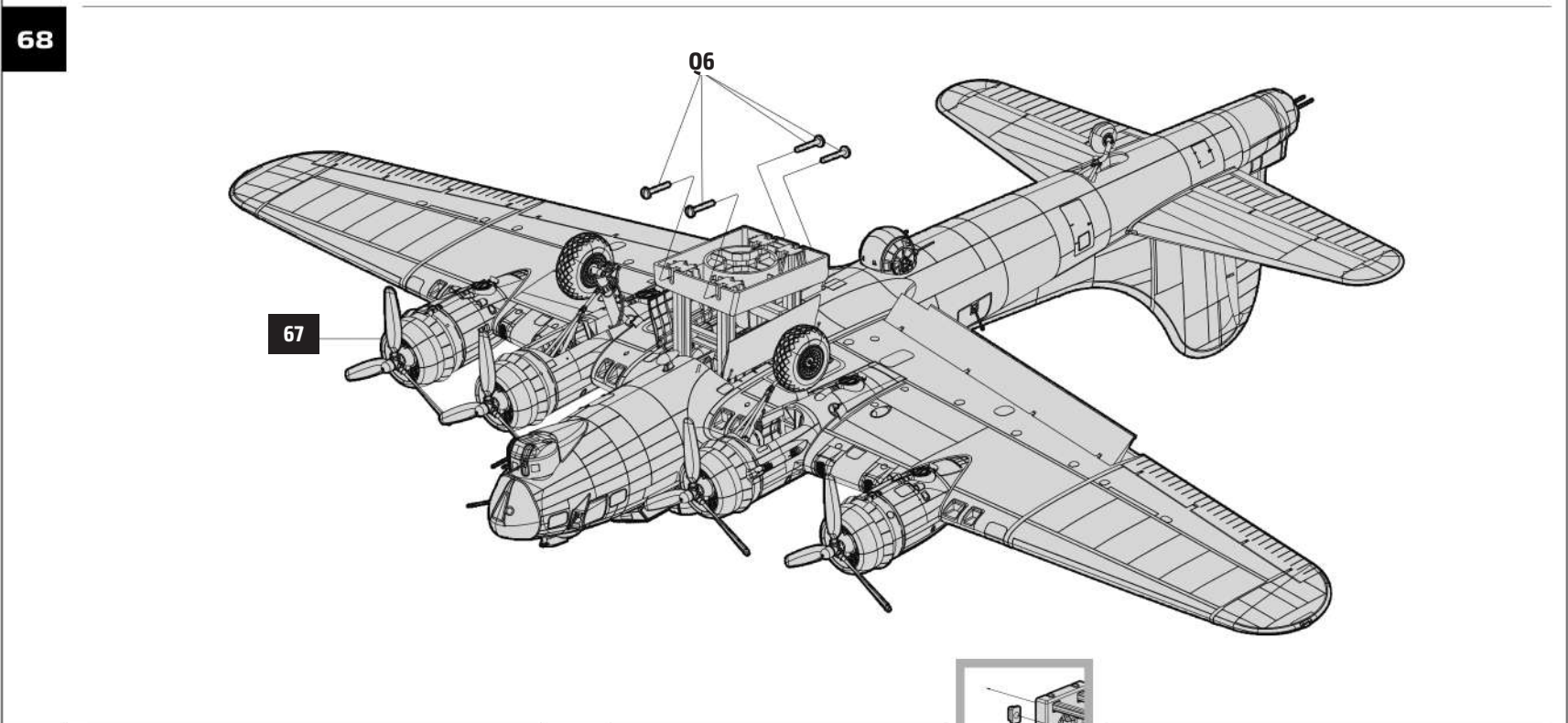
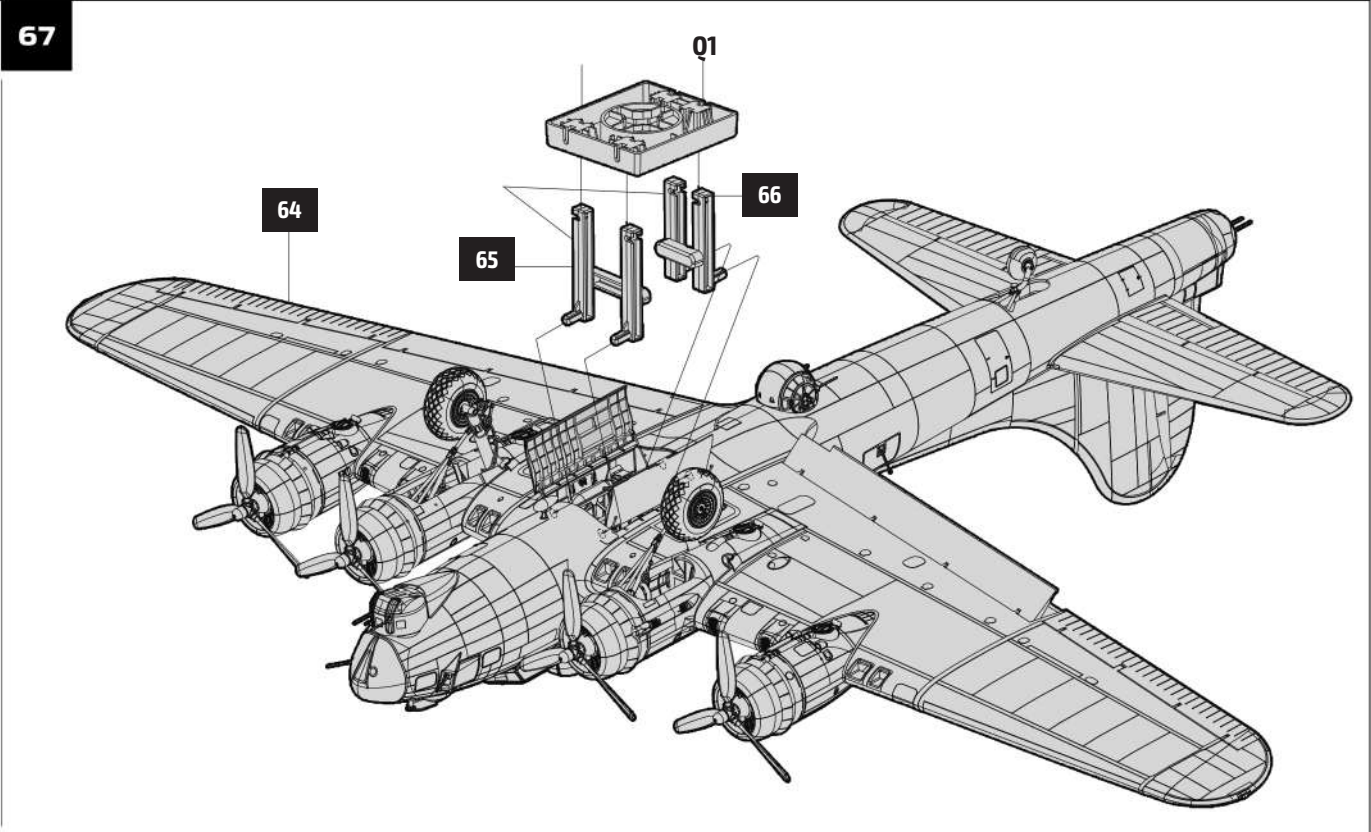
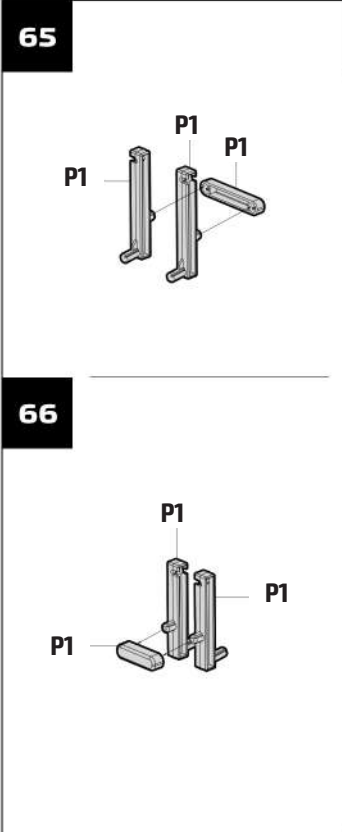

Parts

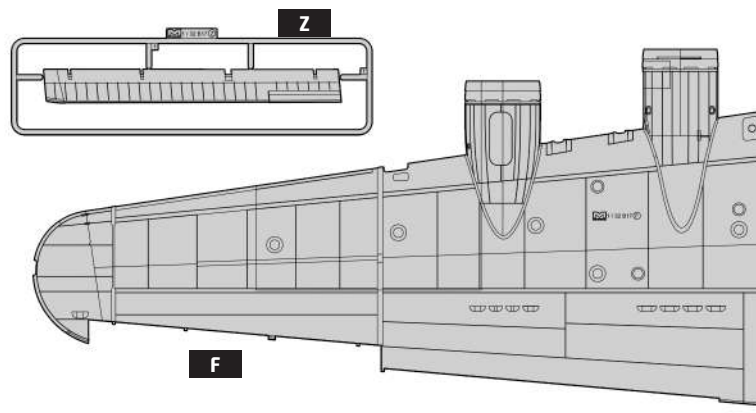
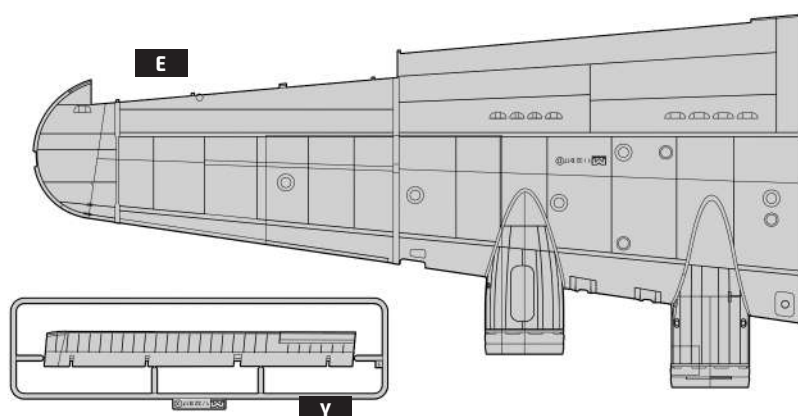
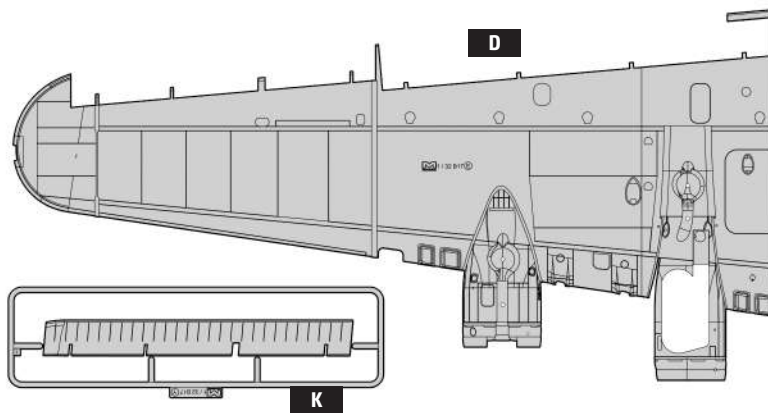
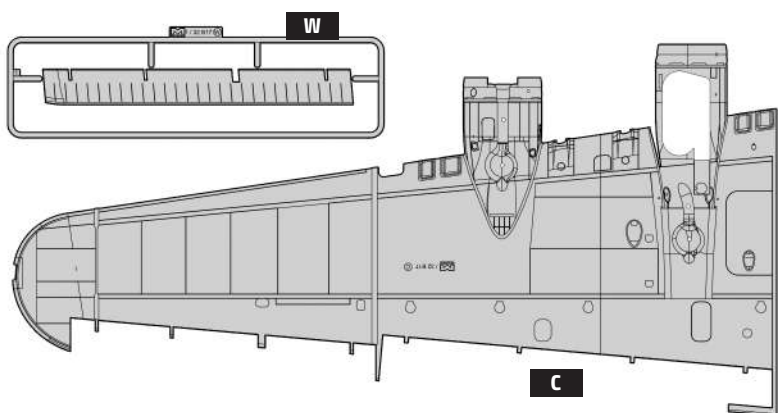
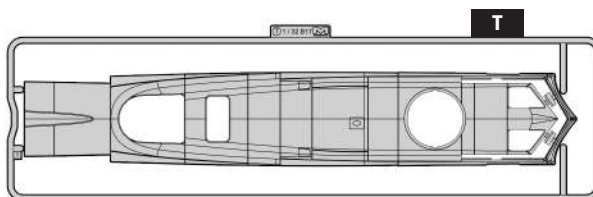
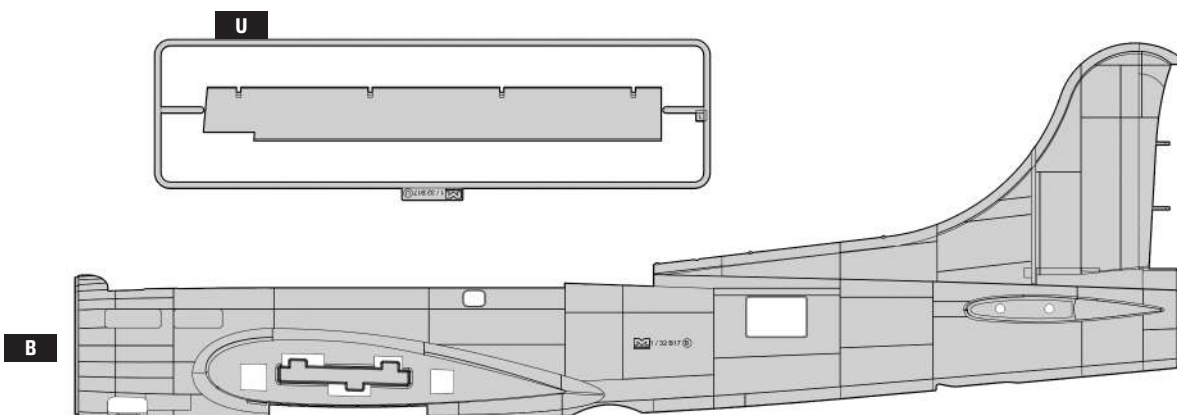
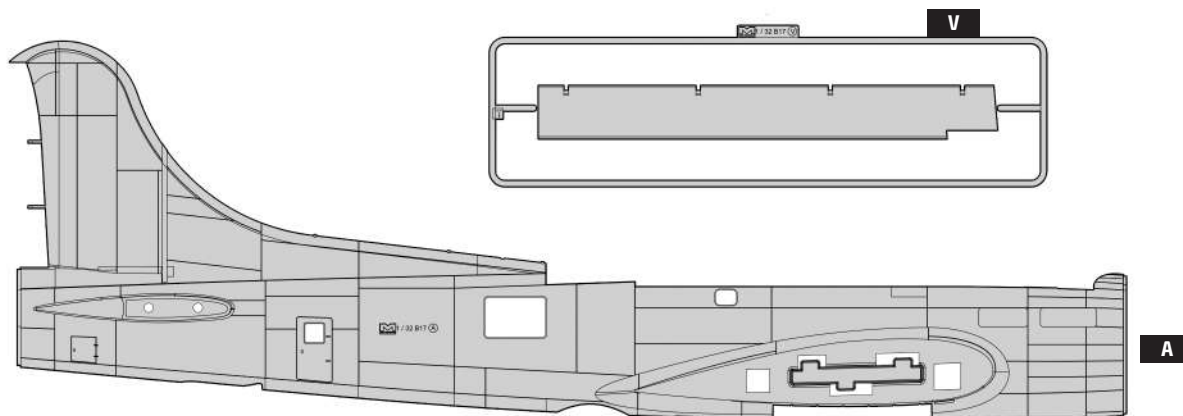

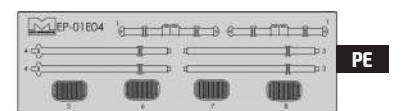
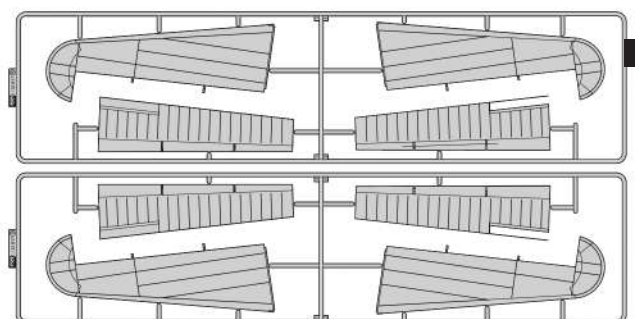
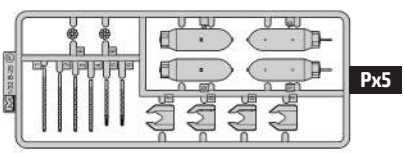
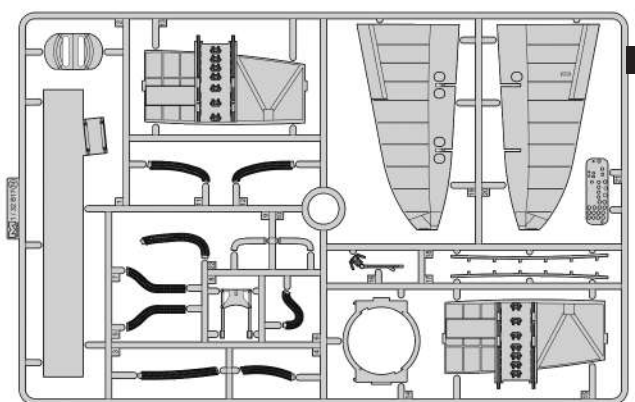
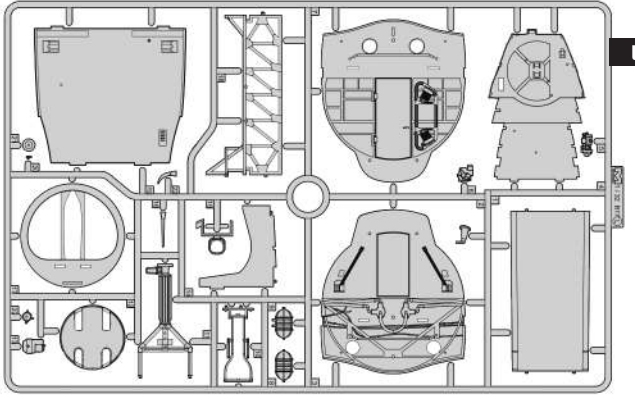
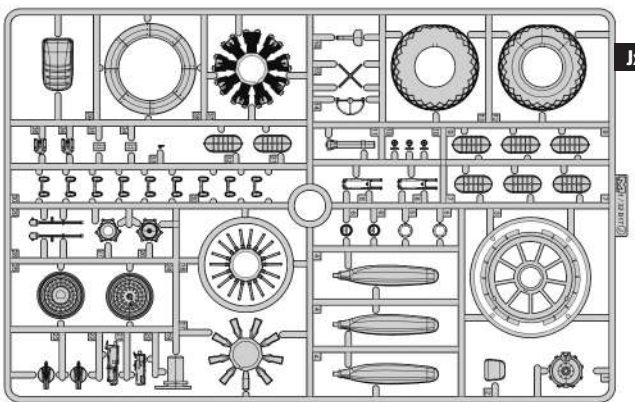
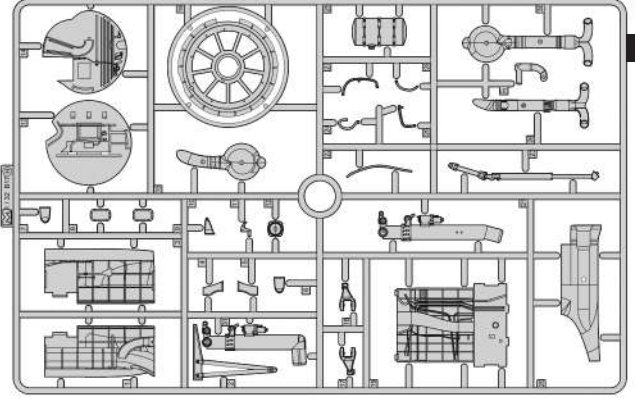
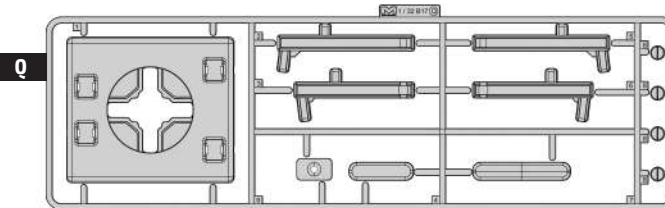
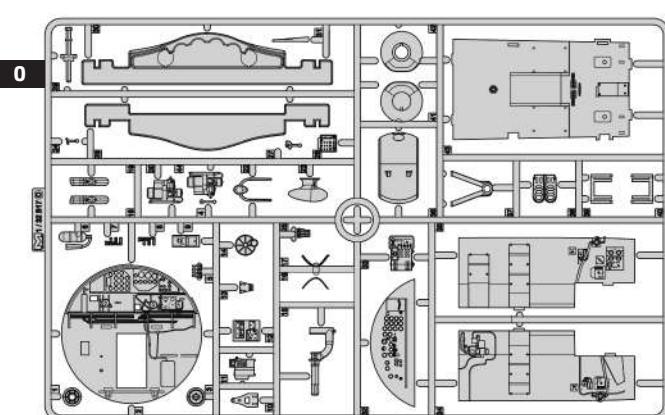
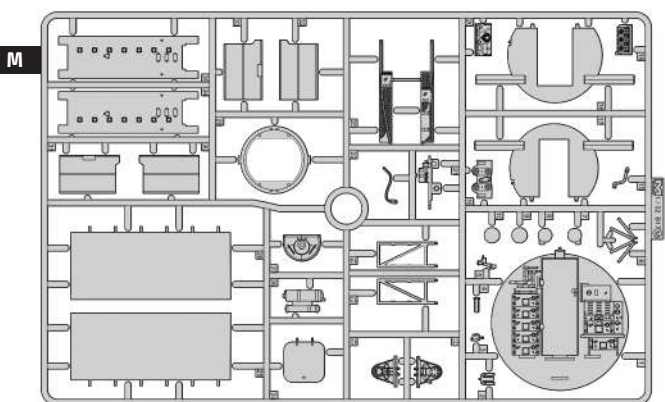
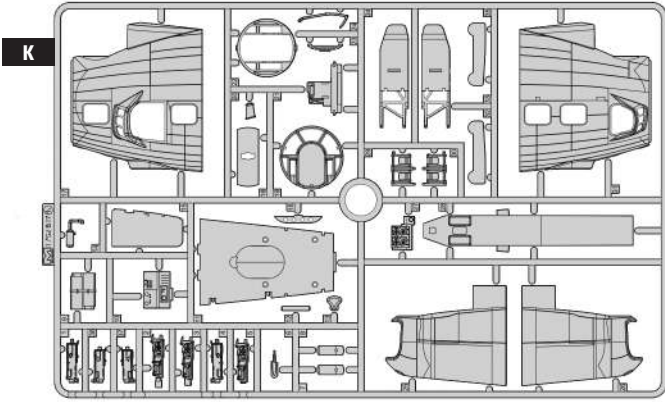
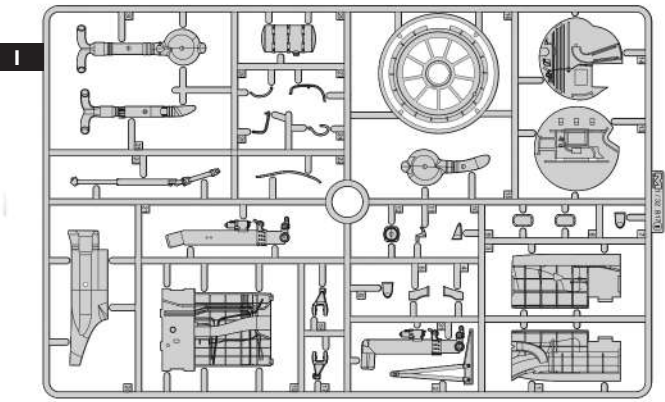
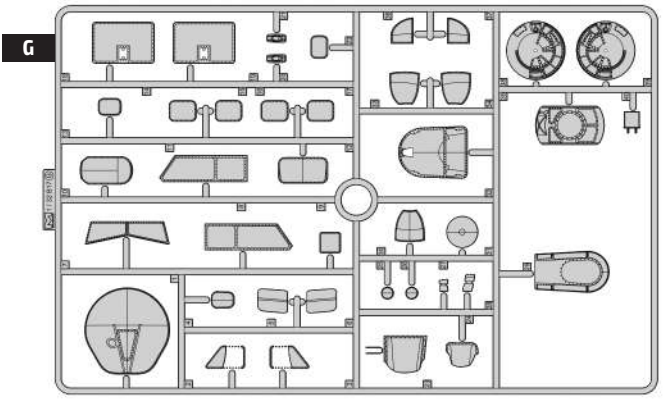

MARKING

A

B-17G-95-B0, s/n 43-38728, 851st BS / 490th BG, 8th AF, early 1945.

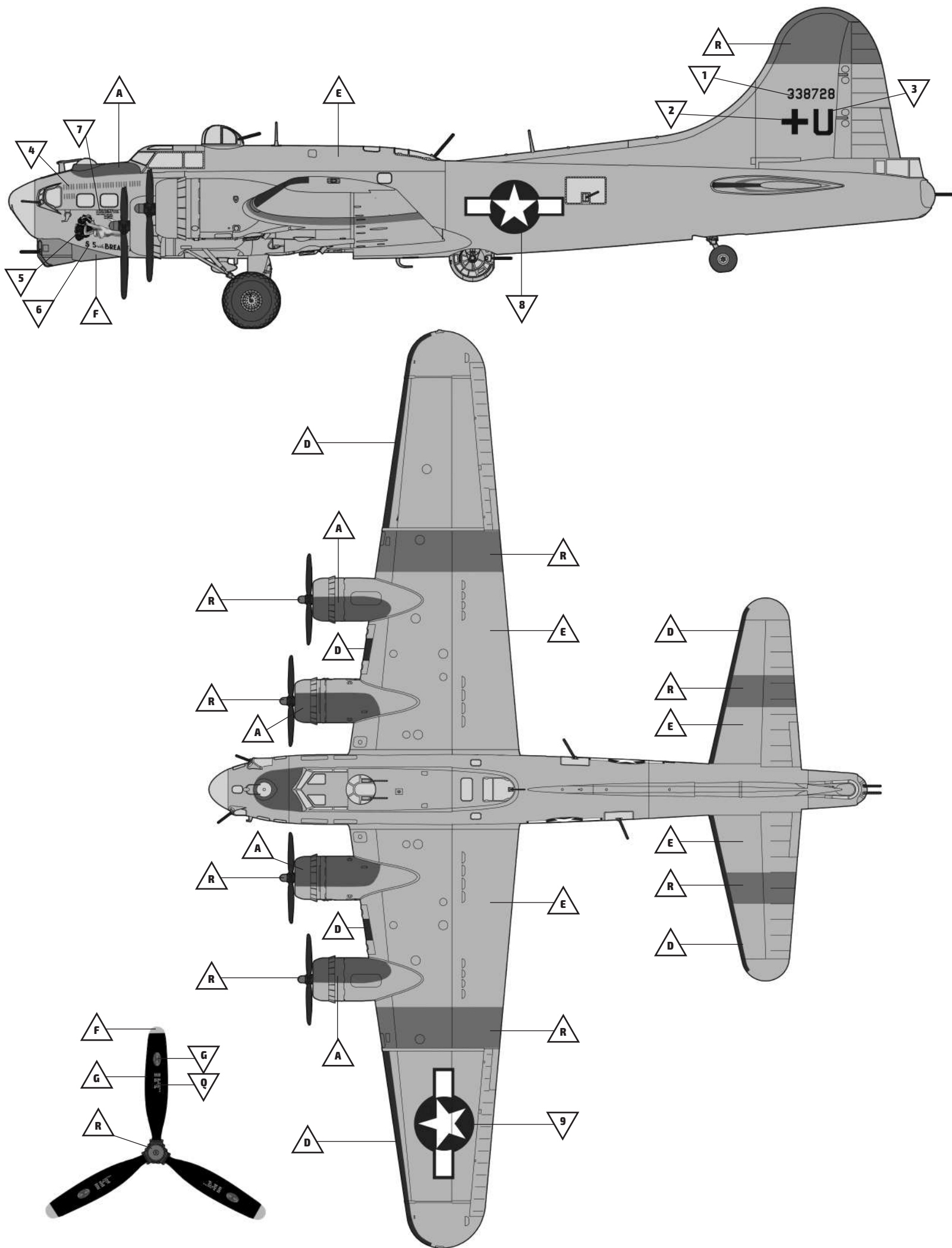

MARKING

A

B-17G-95-B0, s/n 43-38728, 851st BS / 490th BG, 8th AF, early 1945.

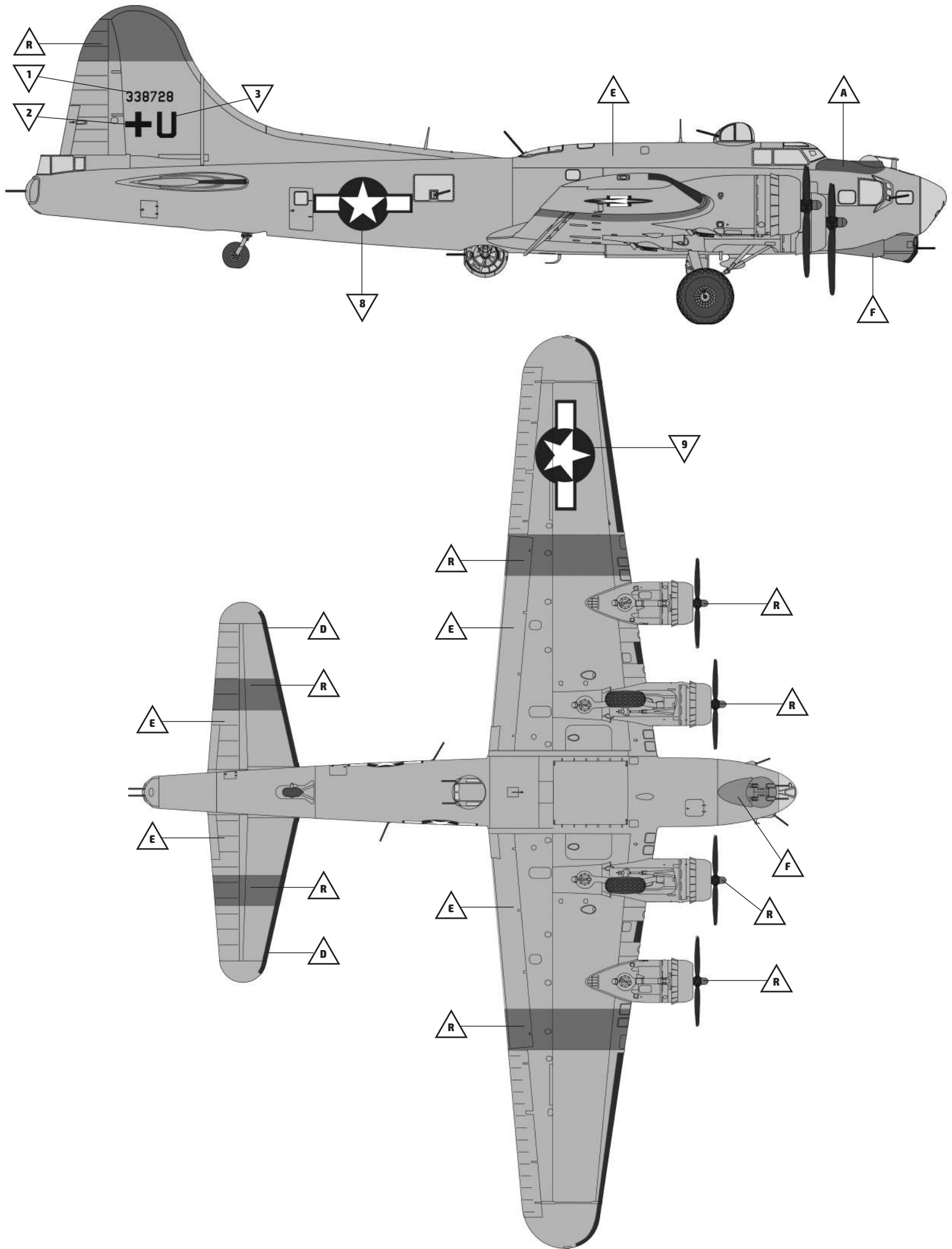

MARKING

B

B-17G-70-B0, s/n 43-37756, 708th BS / 447th BG, 8th AF, April 1945.

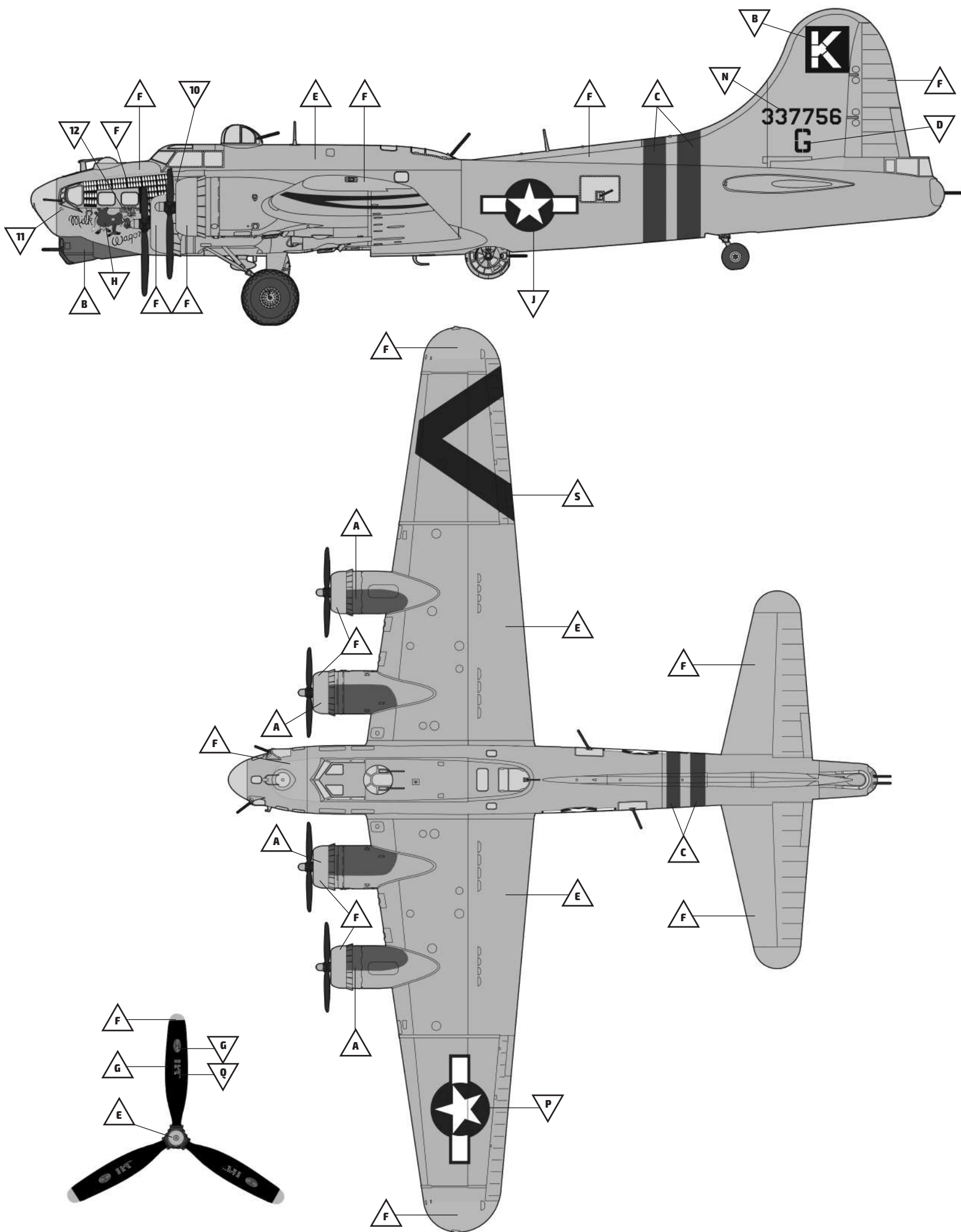

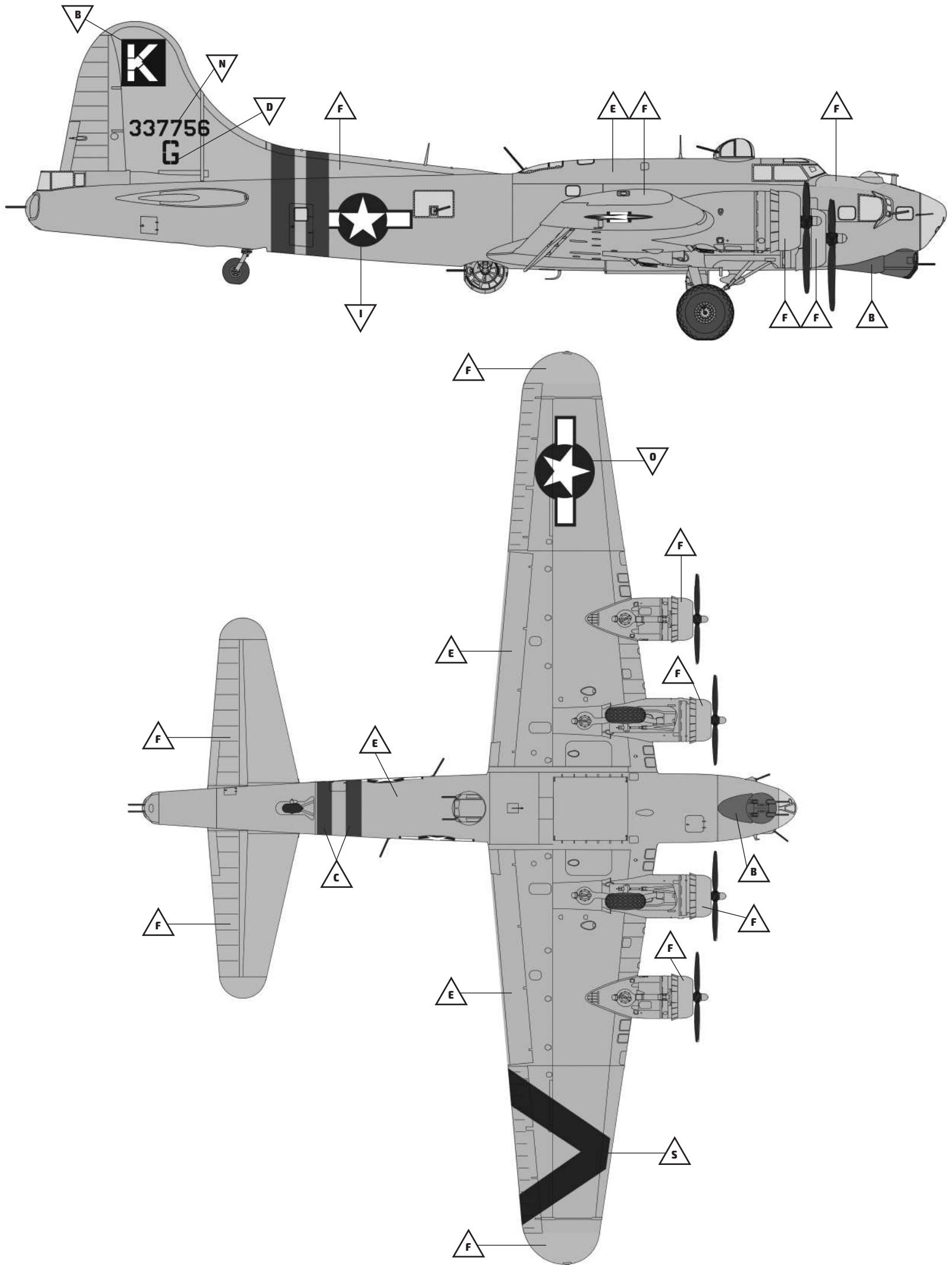

Colour Guide

Key	Gunze/Mr.Hobby	Tamiya	AK Interactive
A: Dark Olive Drab 41	H52	XF-62	AK2201
B: Neutral Grey 43	H53	XF-53	AK2203
C: Medium Green 42	H302	XF-26	AK2202
D: Rubber Black	H77	XF-85	RC022
E: Aluminium	MC218	XF-16	AK479
F: Yellow	H4	XF-3	AK2091
G: Flat Black	H12	XF-1	RC001
H: Dull Dark Green	H302:5 + H12:1	XF-26:5 + XF-1:1	AK2106
I: Gunmetal	MC214	X-10	AK483
J: Brass	MC219	X-12	AK4002
K: Steel	H18	XF-56	AK476
L: Wood	H37	XF-64	AK780
M: Grey	H75	XF-54	AK164
N: White	H11	XF-2	RC004
O: Light Green	H50	XF-71:4 + XF-2:1	AK173
P: Clear Red	H90	X-27	RC503
Q: Clear Green	H94	X-25	RC505
R: Red	H327	-	RC005
S: Insignia Blue	H326	-	-

In cooperation with:



www.ak-interactive.com



www.largescalemodeller.com

Illustration, manual layout and format: **Tomek Wajnkaim & AK-Interactive**
 Manual and assistance: **AK-Interactive**
 Introductory text: **James Hatch**