

Plastic model kit containing 332 parts.

Wing span: 431 mm Length: 433 mm

1/32  
SCALE

















01E09

# Dornier Do335 A-10 Trainer

**Was** there any aircraft as unorthodox and unconventional in appearance as the Dornier Do 335? Of course there was, but the Do 335 was to be a mass-produced fighter-bomber aircraft that would have entered regular service. What made this aircraft an interesting proposition was its configuration. This was indeed a two-engine design, but centred around an unusual push-pull design. That in itself might make the aircraft sound like a non-starter, but the Do 335 was arguably one of, or THE fastest piston-engine aircraft that ever saw service, as the design eliminated the traditional parasitic drag element that was typical for a standard two-engine design layout. It was also very versatile. Conceived from the outset as a multirole machine, this adaptable design could be used as a straight fighter aircraft, and also as a night-fighter, complete with a second, tandem crew position that gave that version of the Do 335 its distinctive humpback appearance. Bombs could also be carried in an internal bay, and if you required a heavy fighter, then this was possible by mounting two MK103 cannon in two wing-mounted pods that protruded from the wing leading edge (HK Models kit #01E07).

The Do 335 was also a robust and highly manoeuvrable machine, and one that could actually cope with a rear engine failure. It was also one of the few aircraft of the time

that was fitted with an ejection seat. Should this need to be used, the canopy, rear propeller and upper tail fin would be blasted away by the use of explosive bolts, preventing the pilot from striking them on his way out. Another unusual feature of this aircraft was the cruciform tail layout. A downward pointing fin was included, which would hopefully negate any possible rear propeller damage that could result from an awkward landing. First flown in 1943, the project wasn't without its problems. Whilst the aircraft was inherently stable on both ground and in the air, due to the rear engine resting behind the centre of gravity, it did suffer from some technical issues that were never overcome, such as a weak undercarriage. Despite the great hopes that the Nazis had for the Do 335, like many of their wonder designs, it simply came too late to make any difference, with only 37 being built by the war's end. Allies evaluation of this Do 335 'Pfeil' showed that it was an excellent performer and could have been a serious opponent, had it not been for Germany's lack of production capability and onerous bureaucratic and personal in-fighting. The subject of this kit release are the proposed A-10 25 seat trainer variant, and the prototype that had been completed under the US custody after the end of World War II.

-  BE CAREFUL
-  REMOVE
-  GLUE TOGETHER
-  PLEASE WAIT FOR A FEW MINUTES UNTIL DRY
-  x2 MAKE 2 PIECES
-  DRILL HOLE
-  DO NOT GLUE
-  INSTANT GLUE FOR METAL
-  BEND
-  FILL HOLE
-  3 SEQUENCE OF WORK
-  OPTIONAL
-  USED COLOUR
-  2 APPLY DECAL
-  A MARKING OPTION

#### CAUTION

When using both glue and paint, do not use these near an open flame, due to the flammable properties of these items.

The symbols provided, such as 'X', refer to the basic colours of parts, although a more comprehensive list is supplied for your use for Tamiya, Mr Hobby and AK-Interactive codes.

When removing parts from sprues, take extreme care. Consider correct tools such as Xuron Sprue Cutters

Please check the symbology on the left and familiarise yourself before building this model kit.

In cooperation with:



www.ak-interactive.com



www.largescalemodeller.com

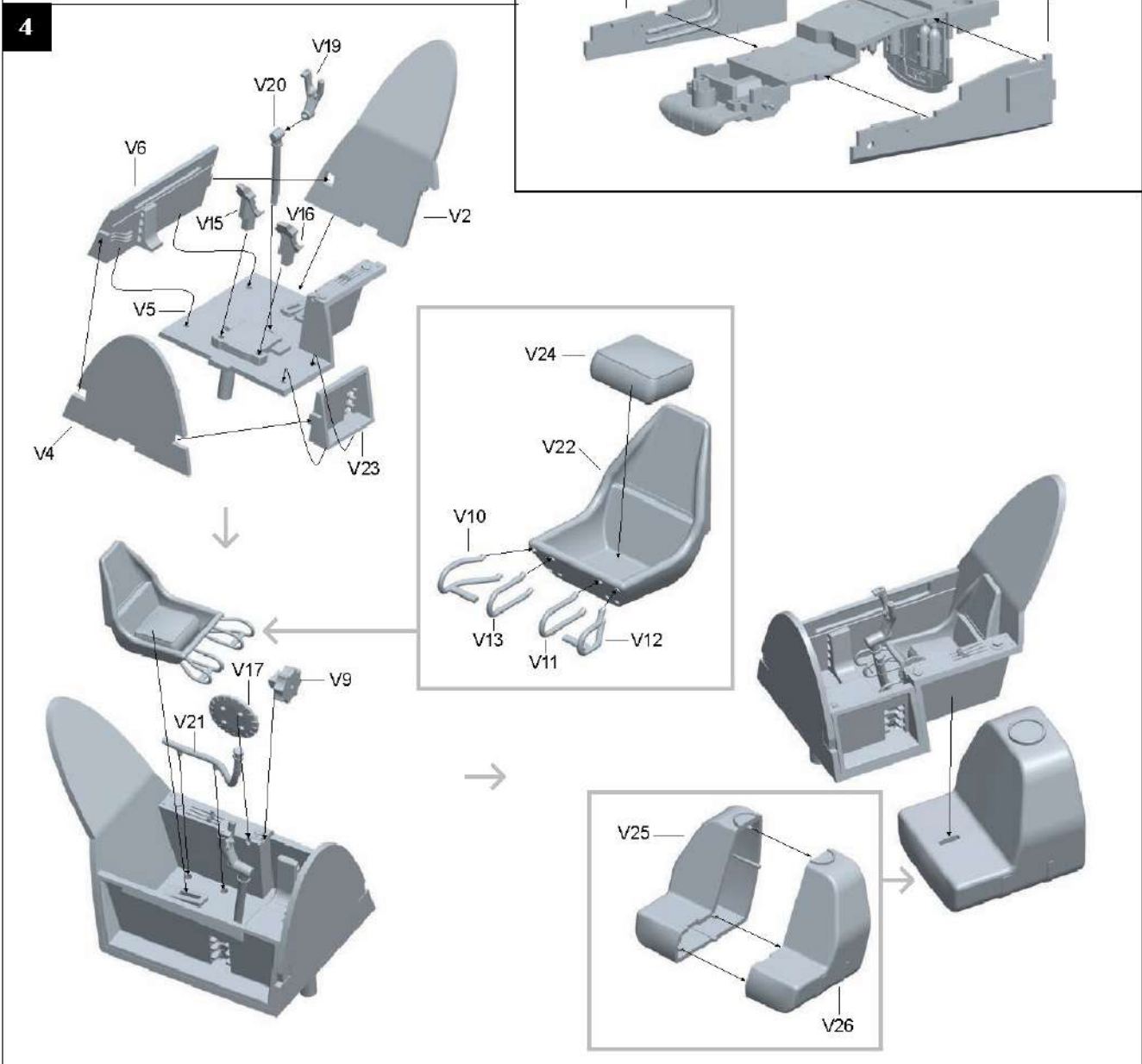
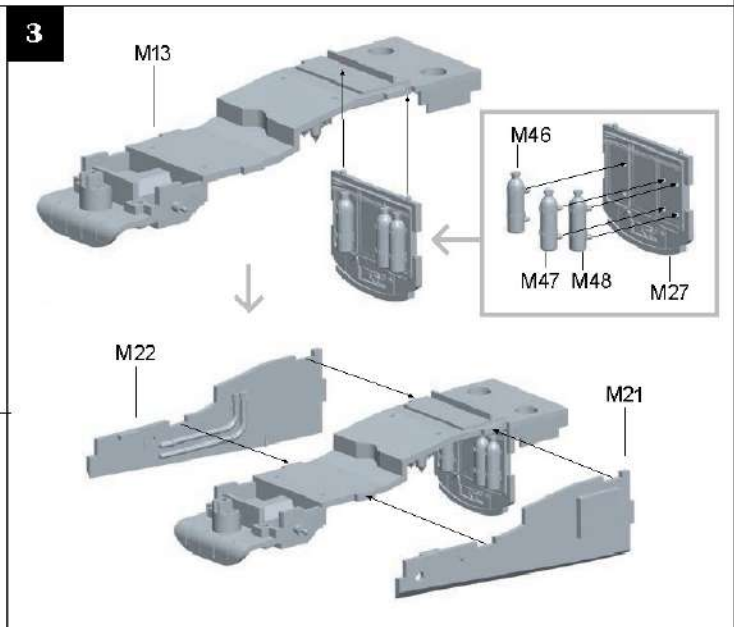
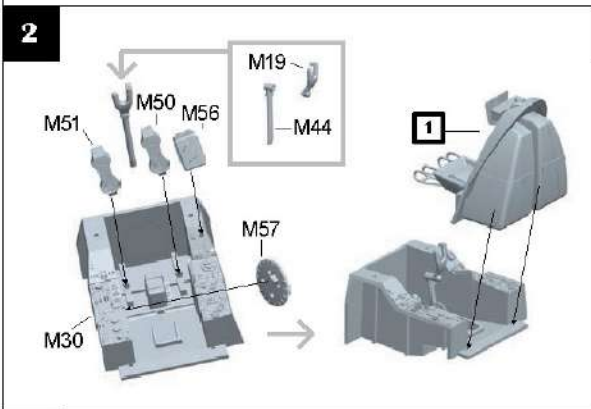
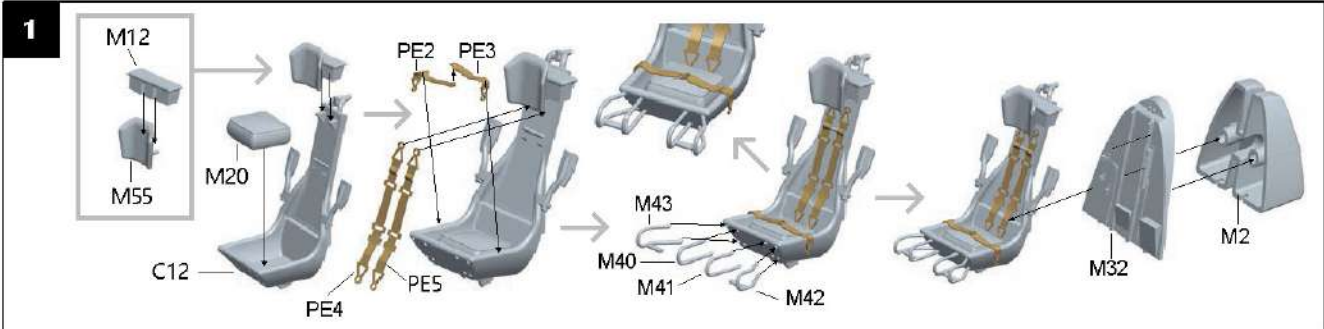

5

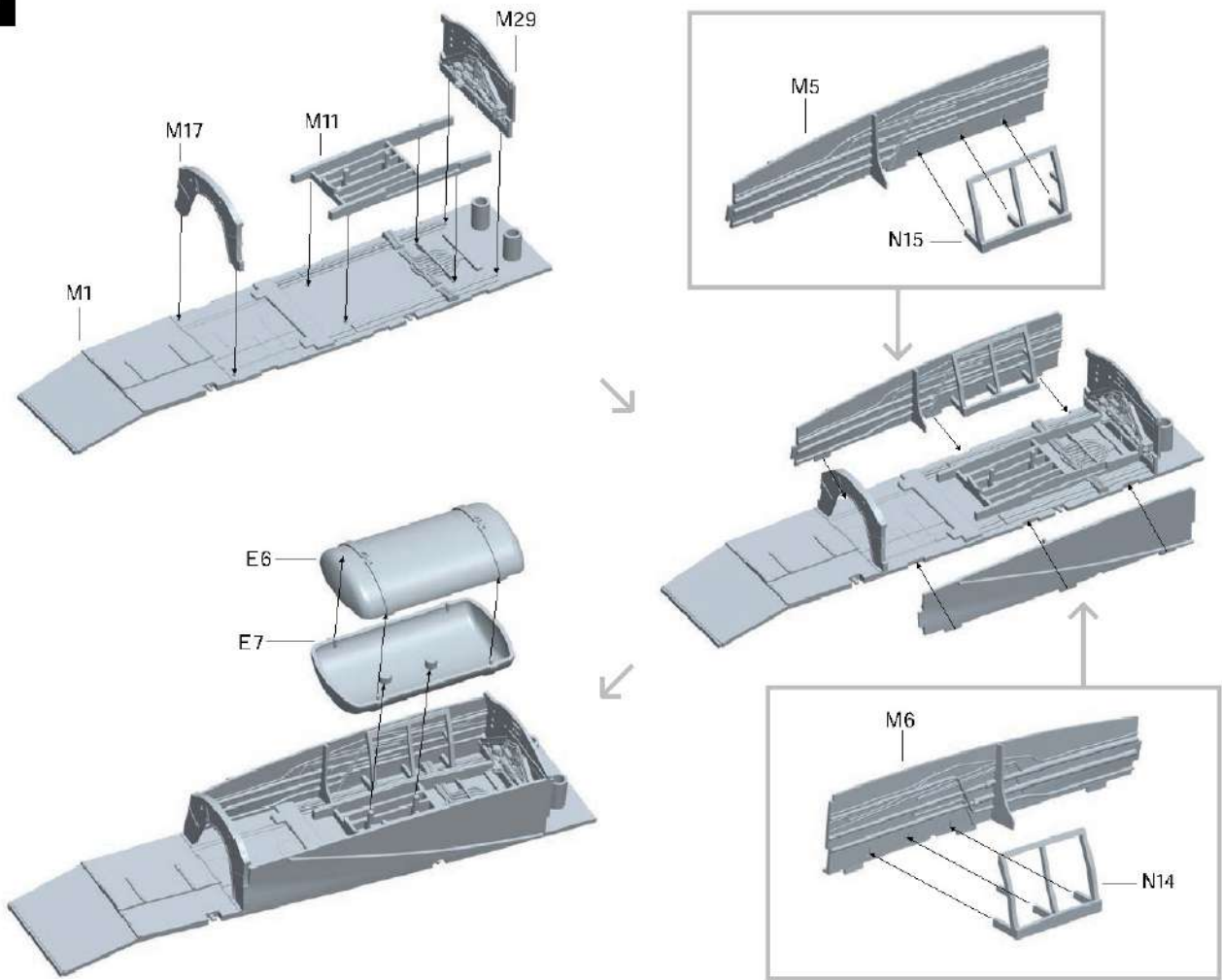

6

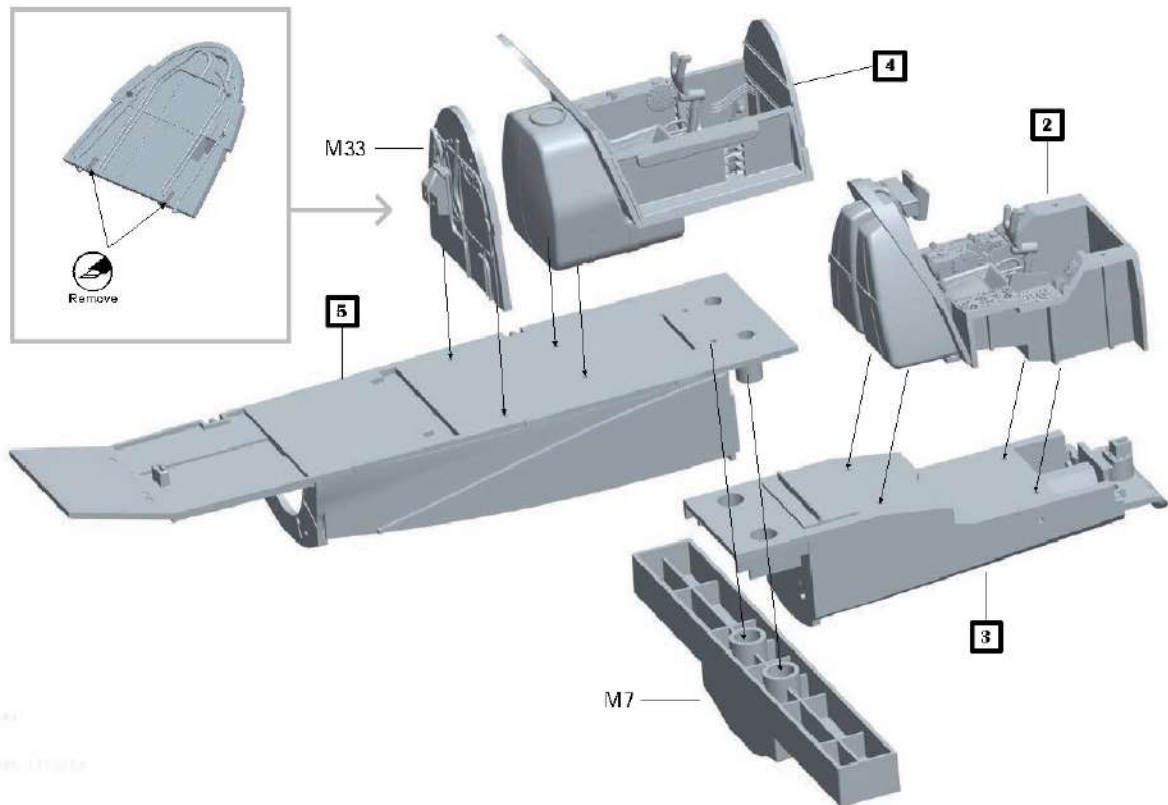

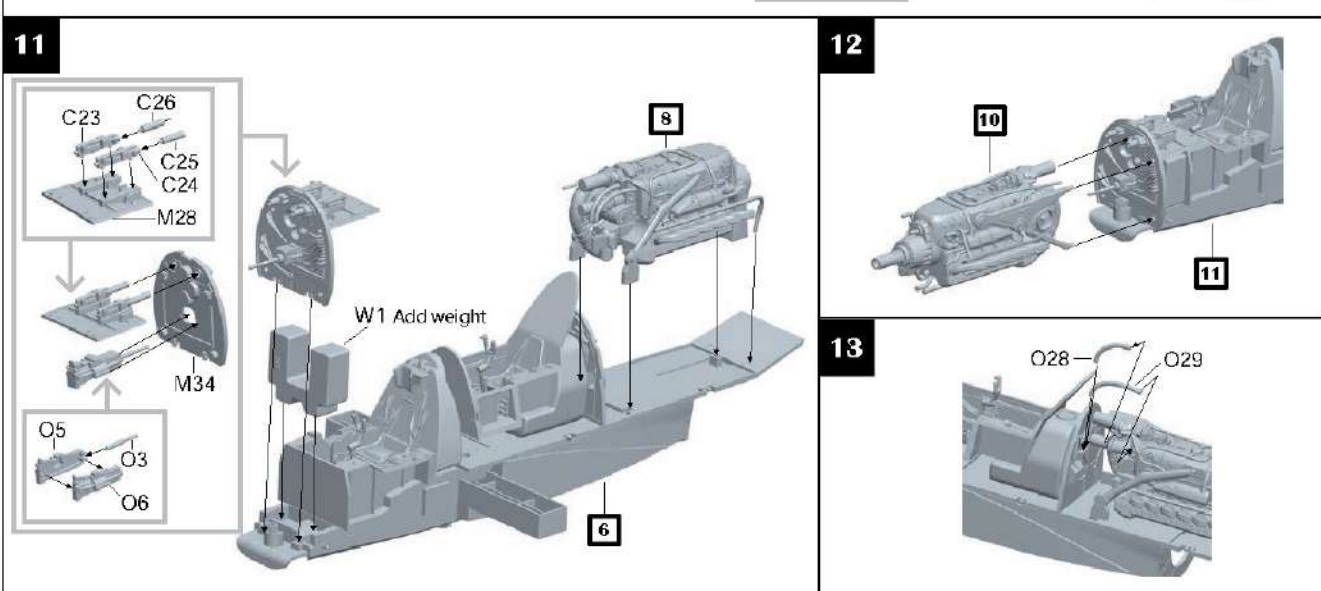
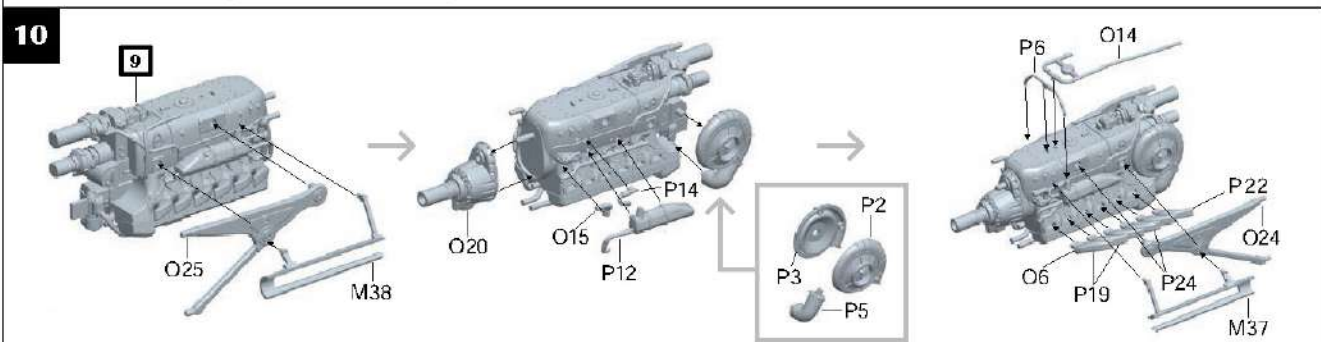
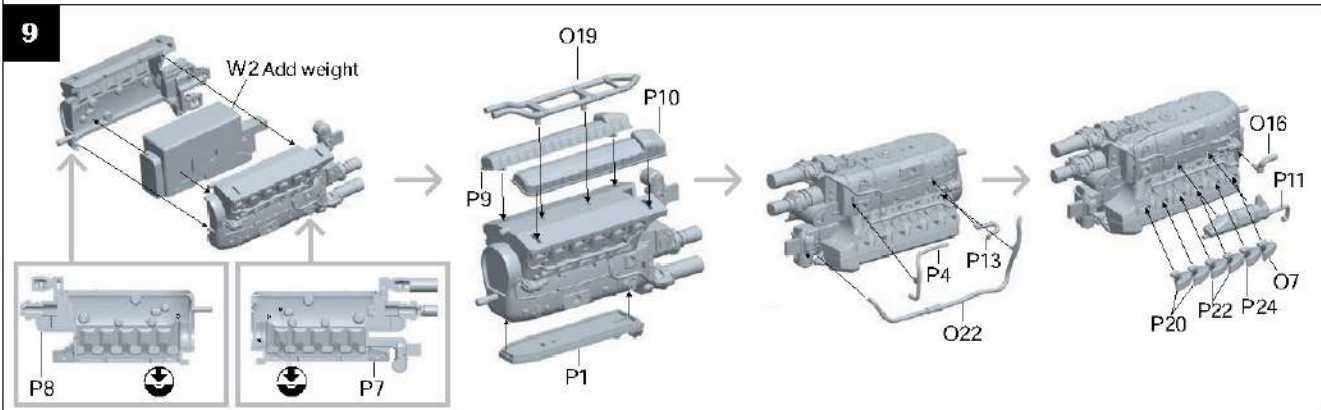
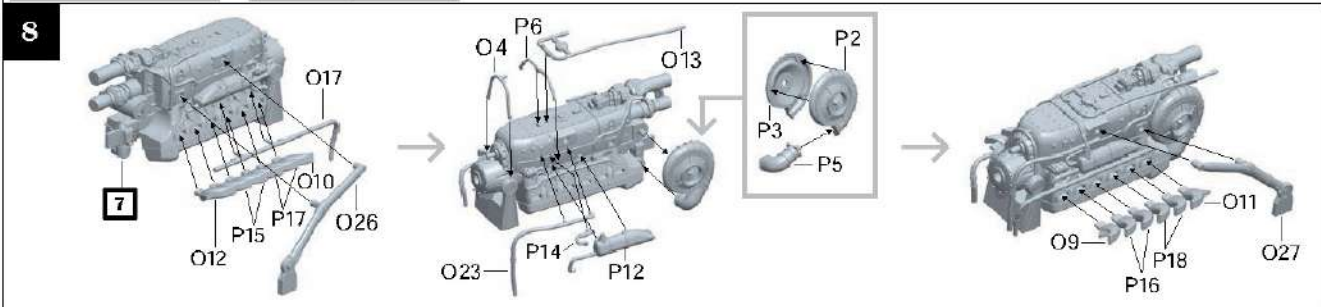
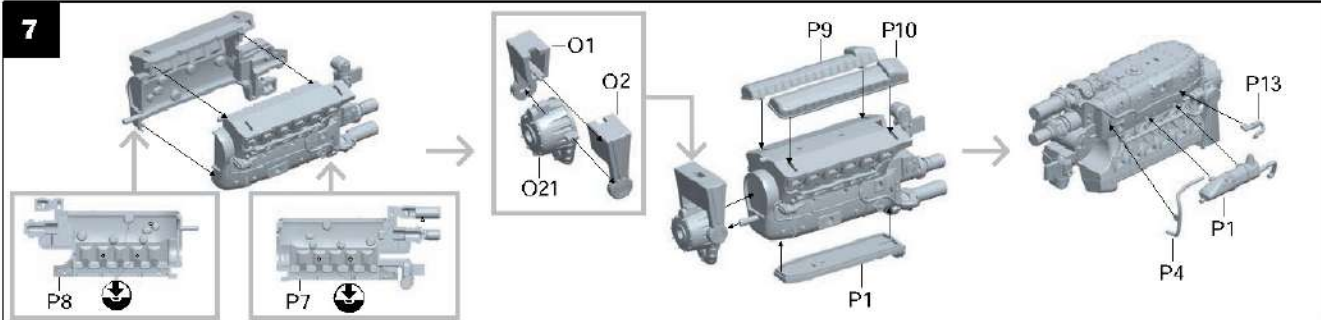

14

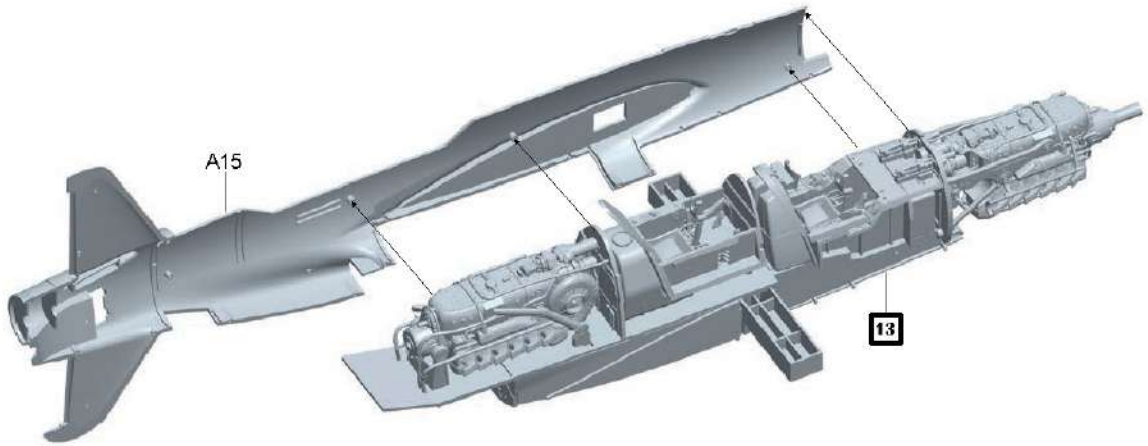

15

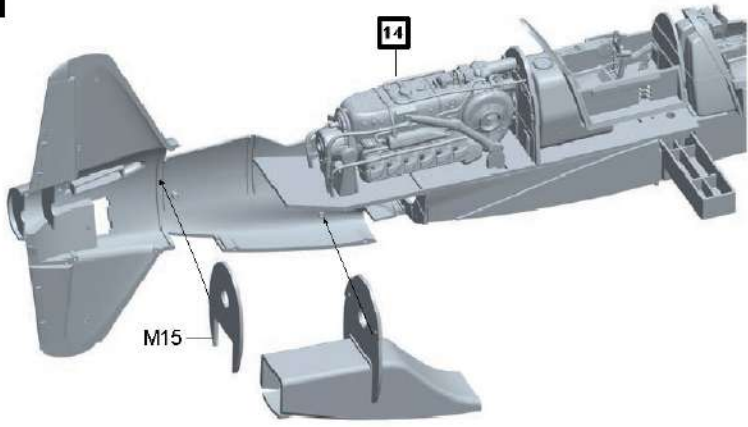

15-1

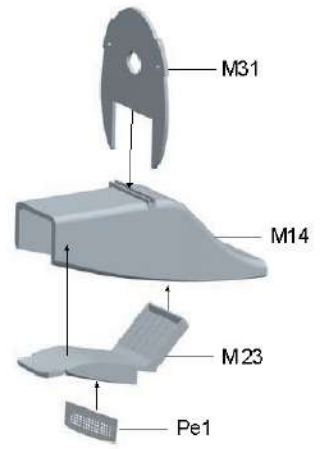

16

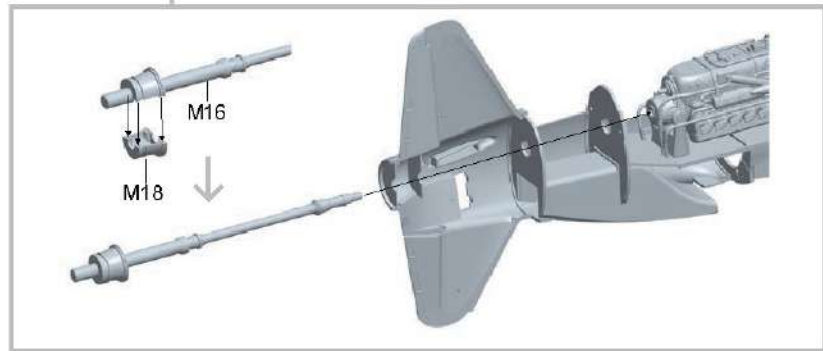
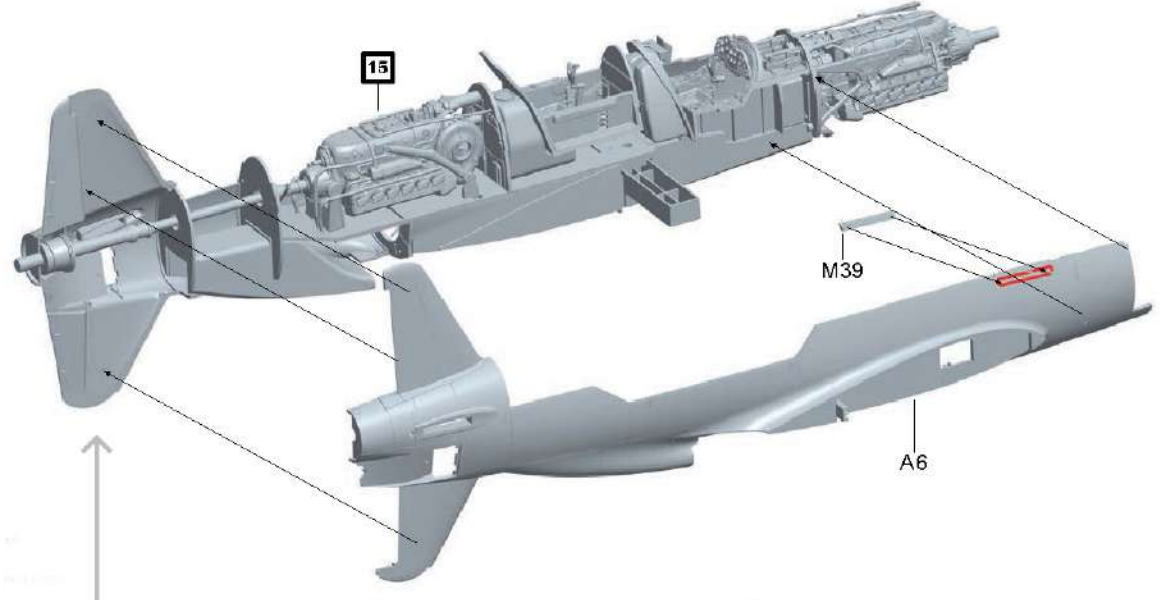

17

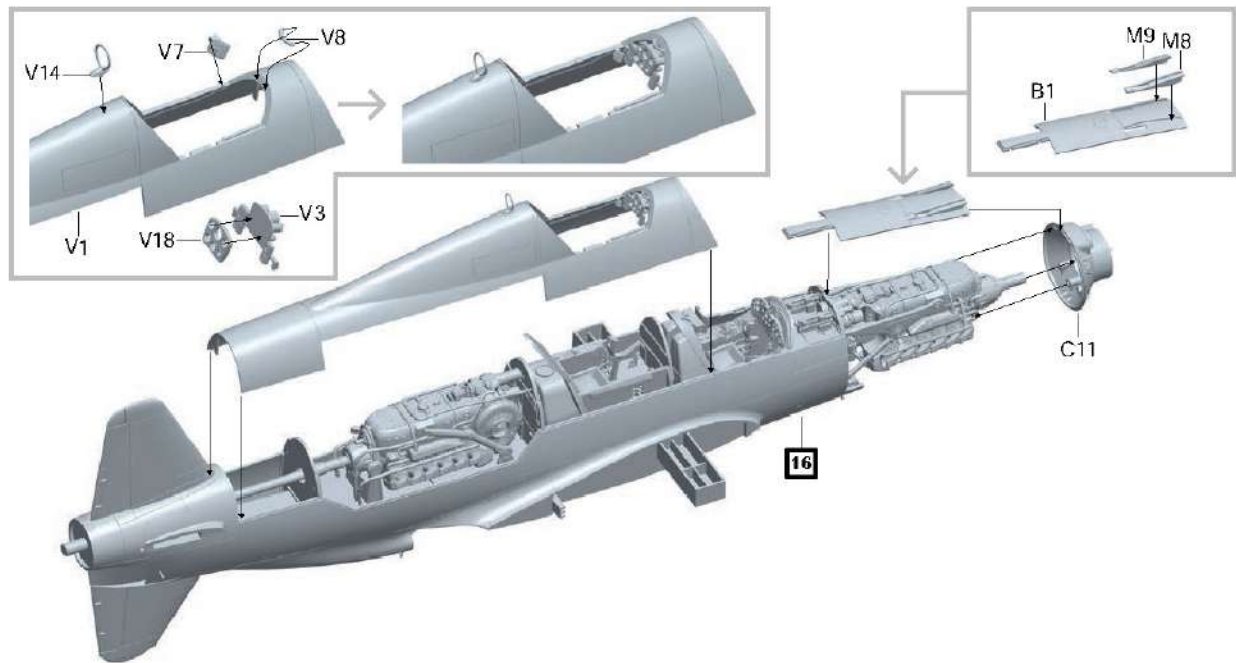

18

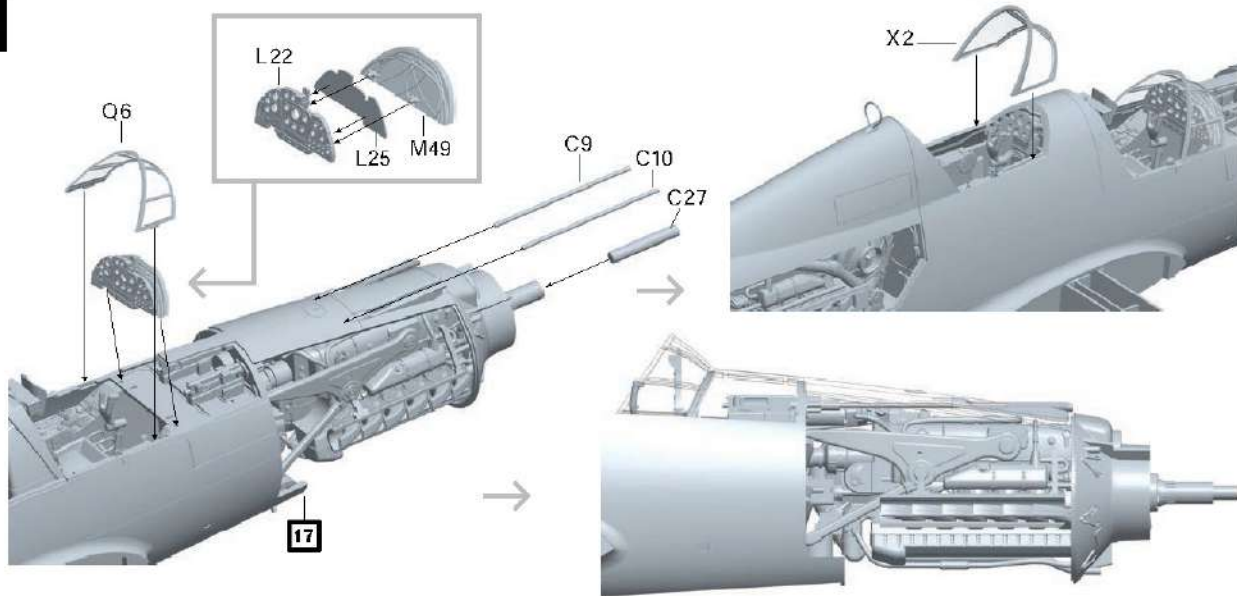

19

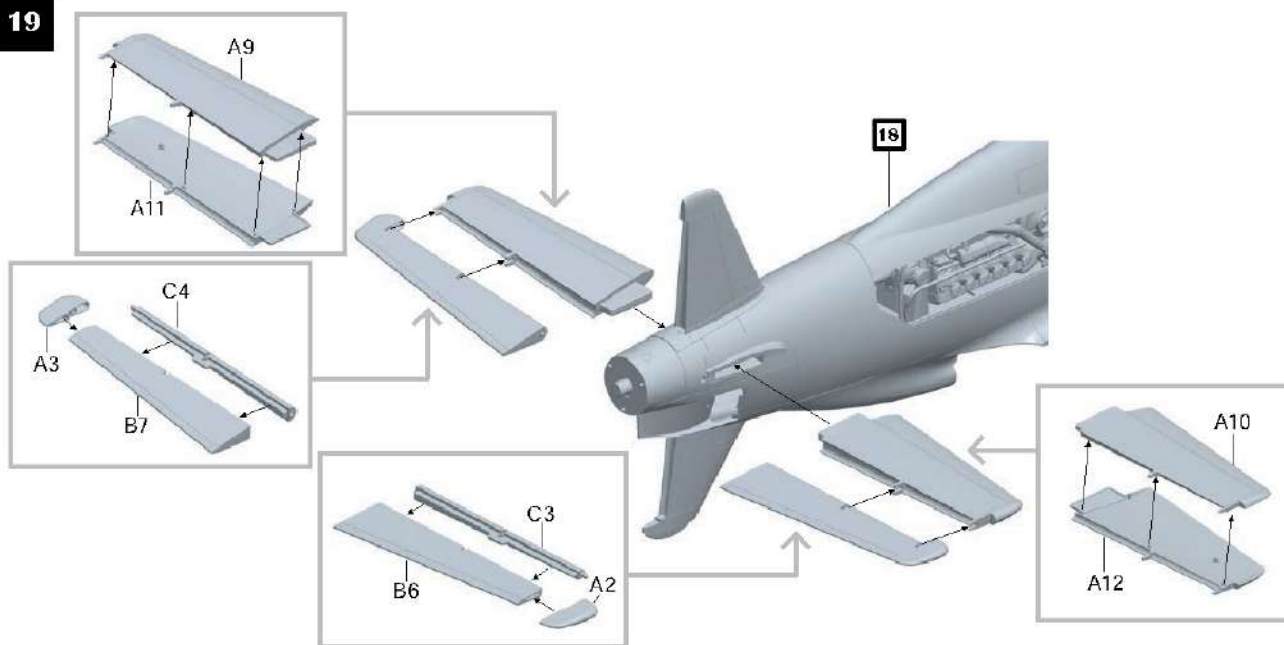

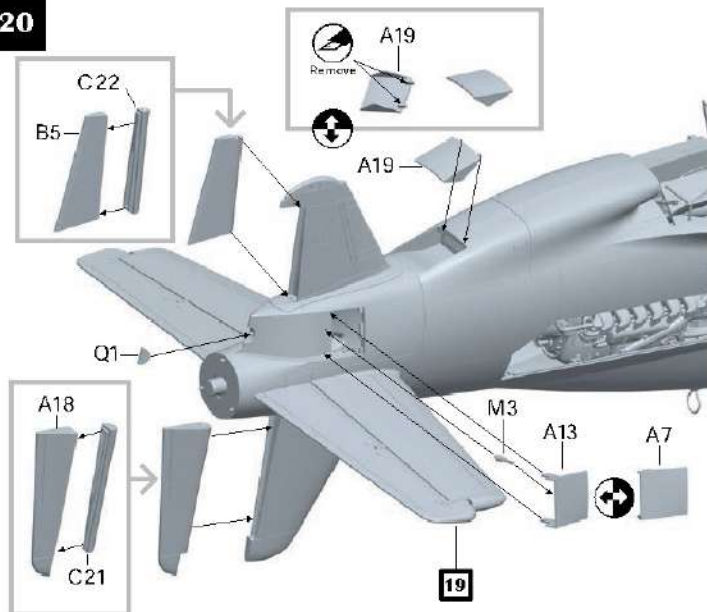
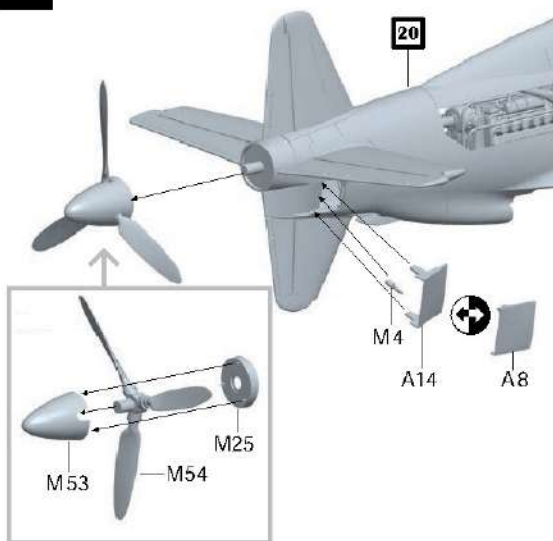
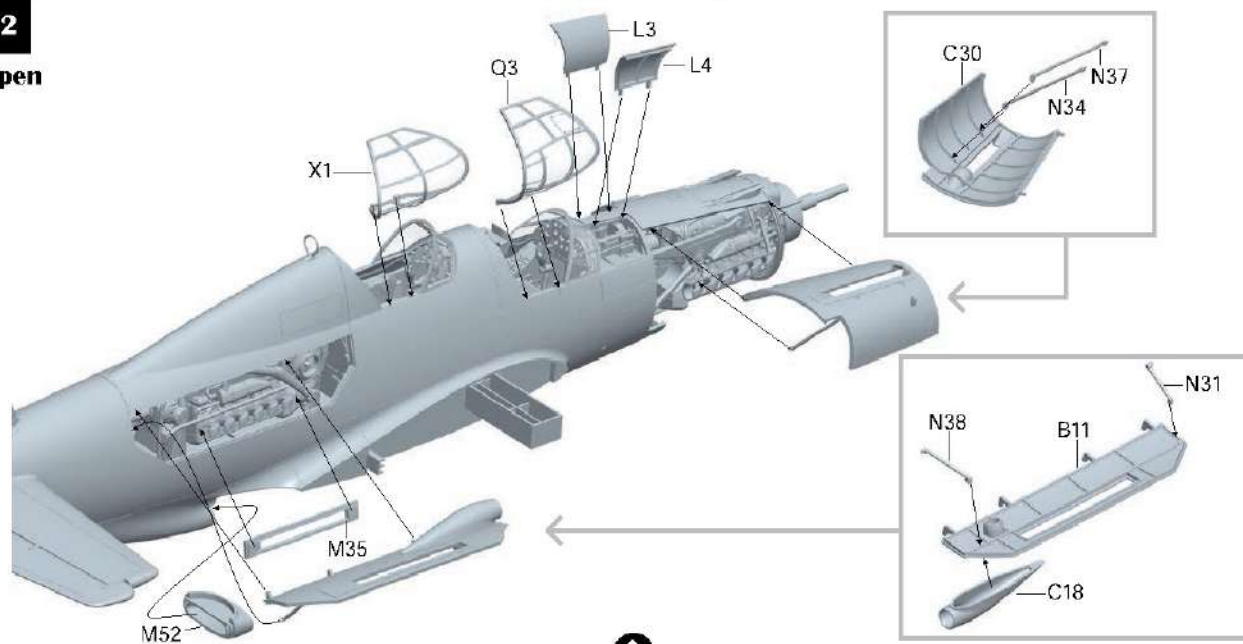
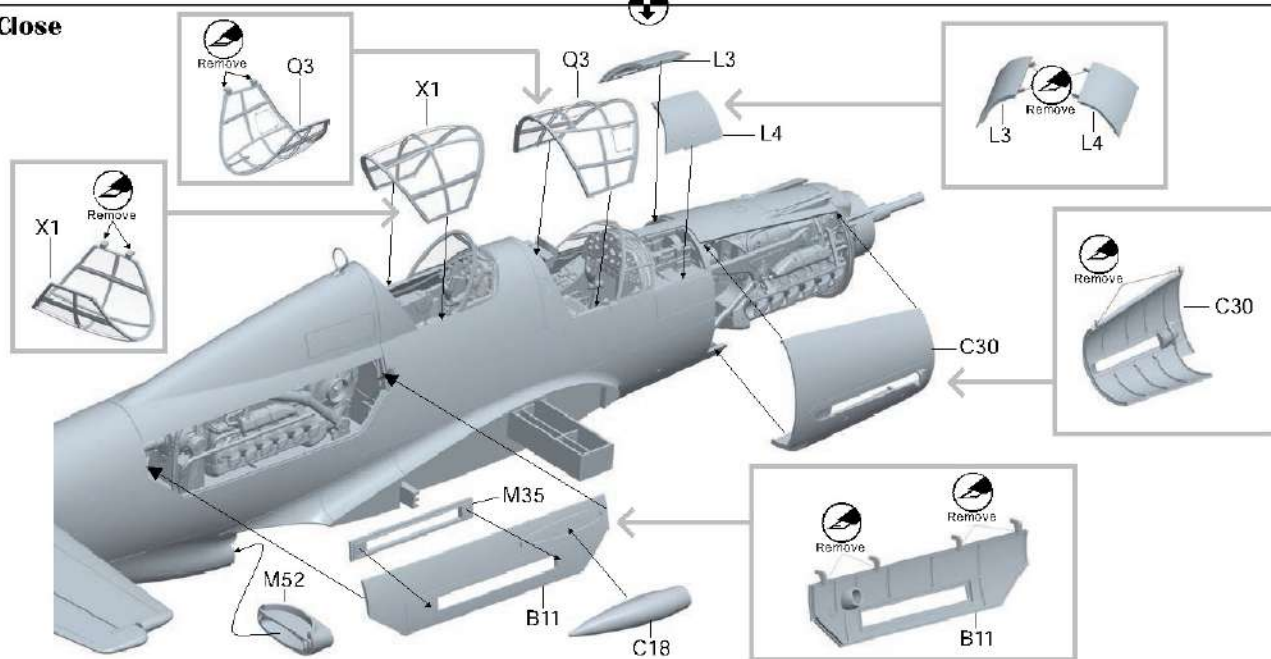
**20****21****22****Open****Close**

23

Open

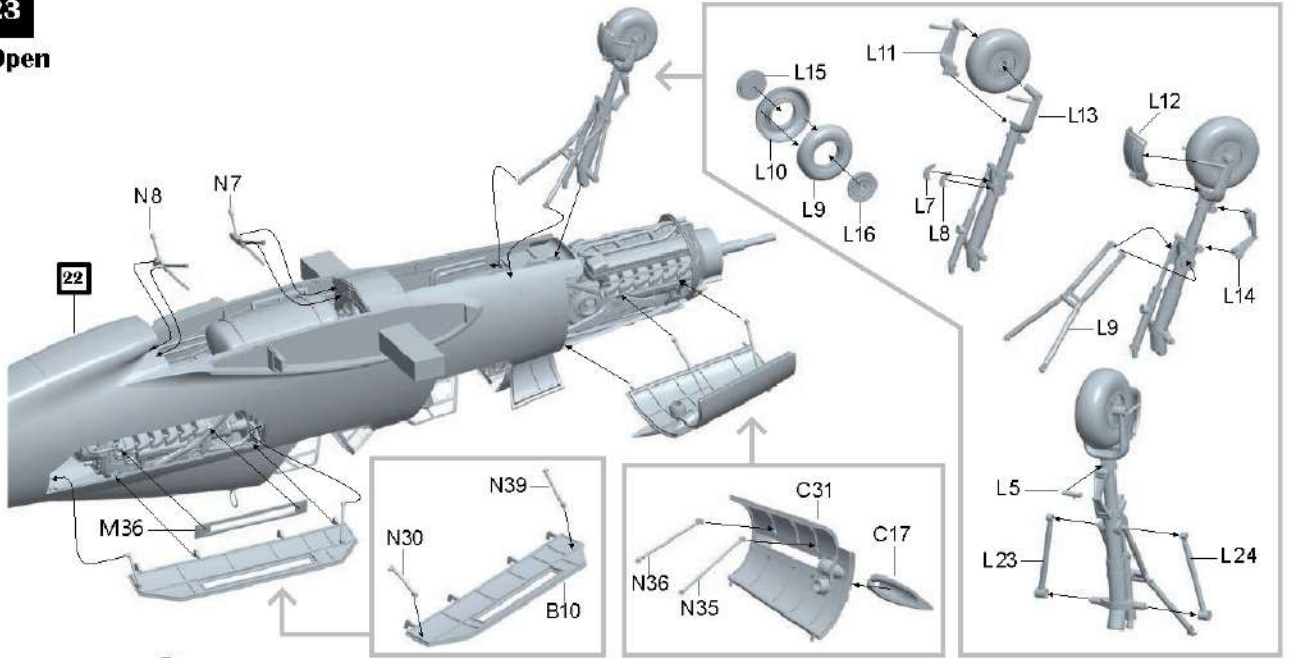

Close

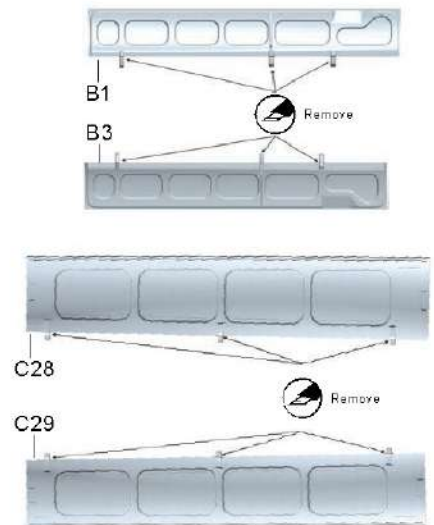
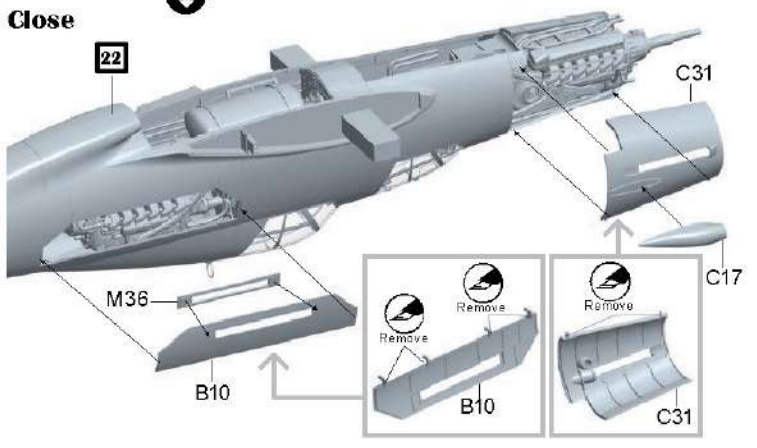

24

Open

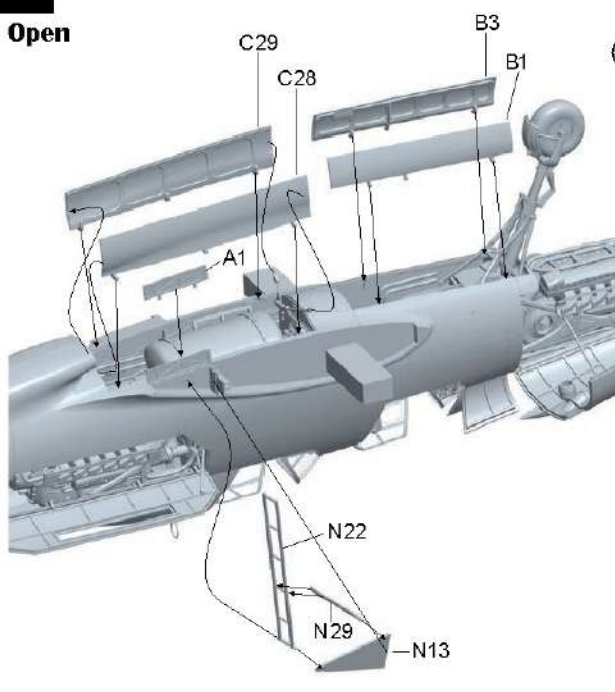

Close

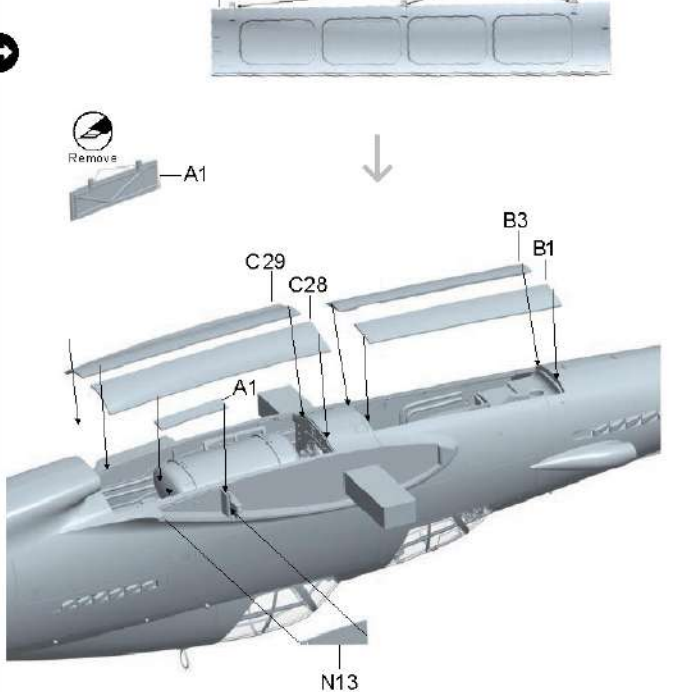



25

Open

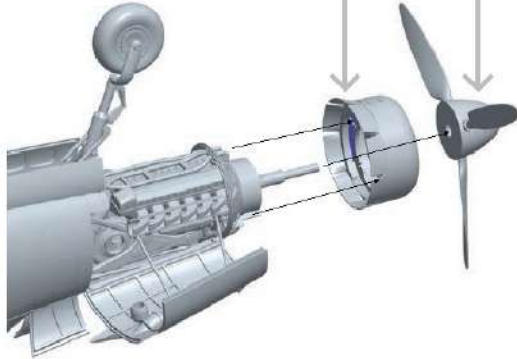

26

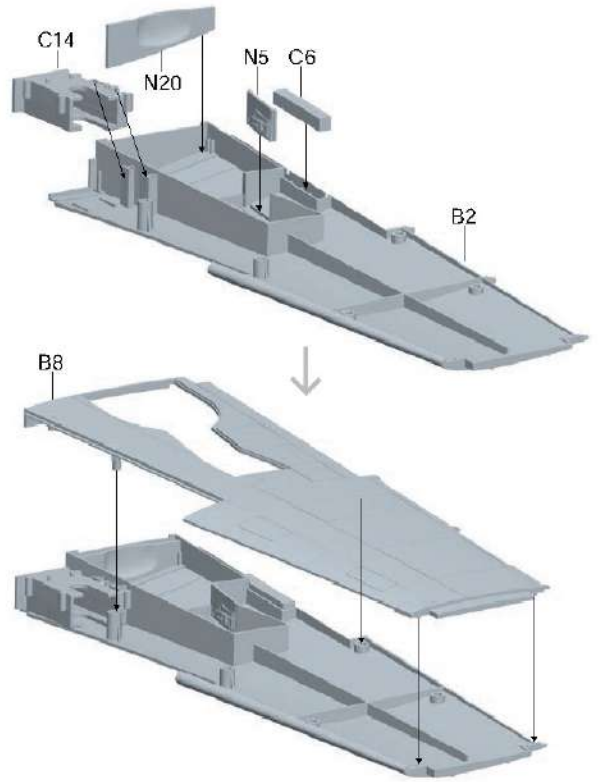

27

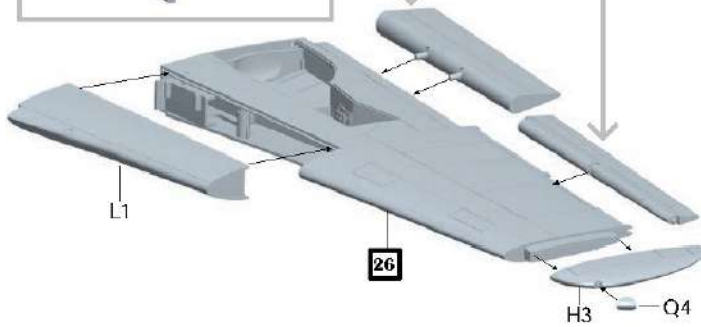
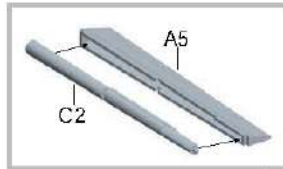
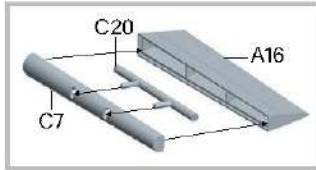

28

Close



Remove

J3

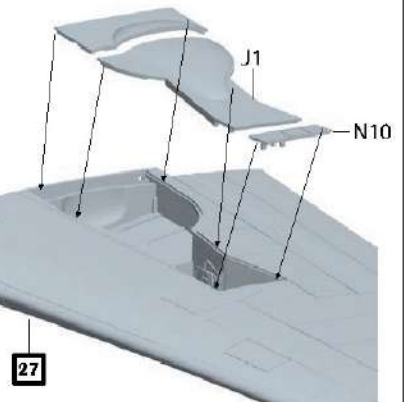

27



Open



27

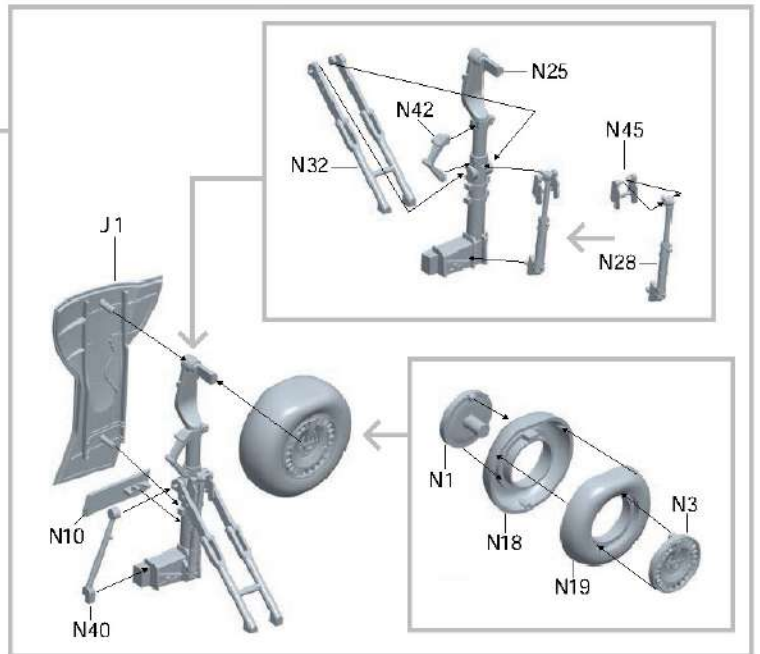

29

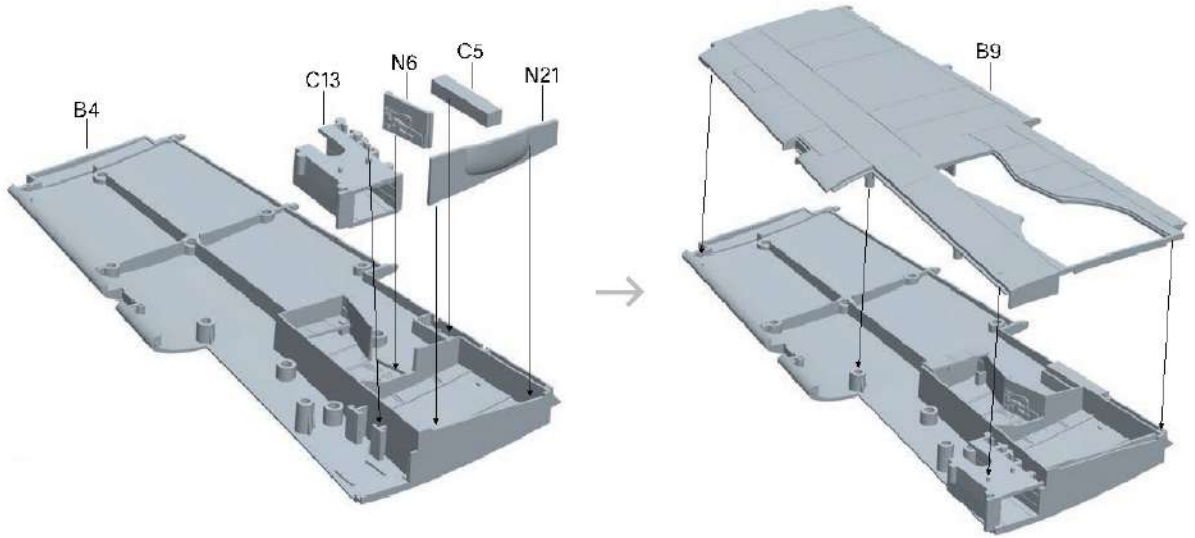

30

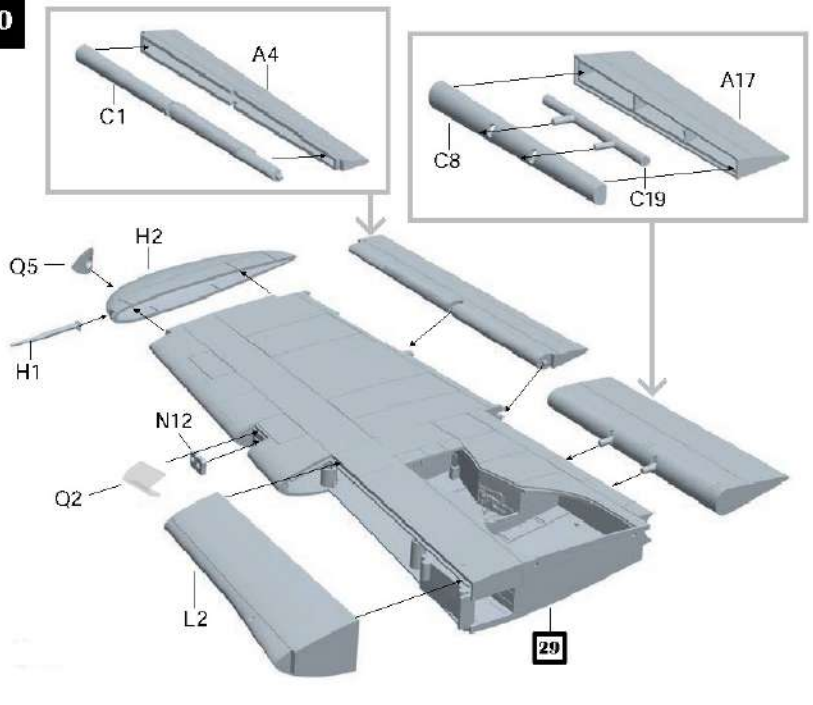

31

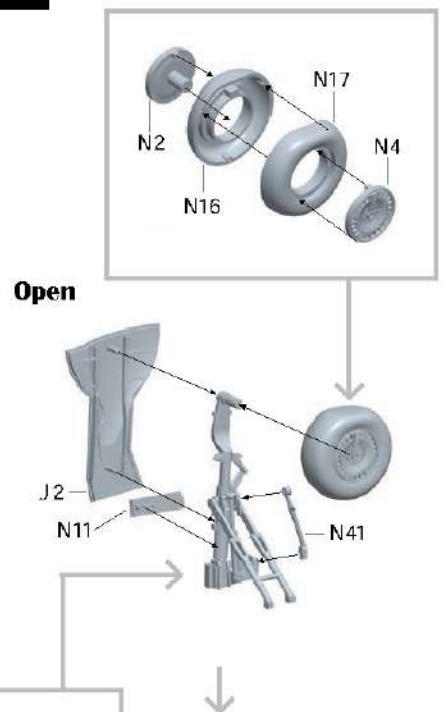

Open

Close

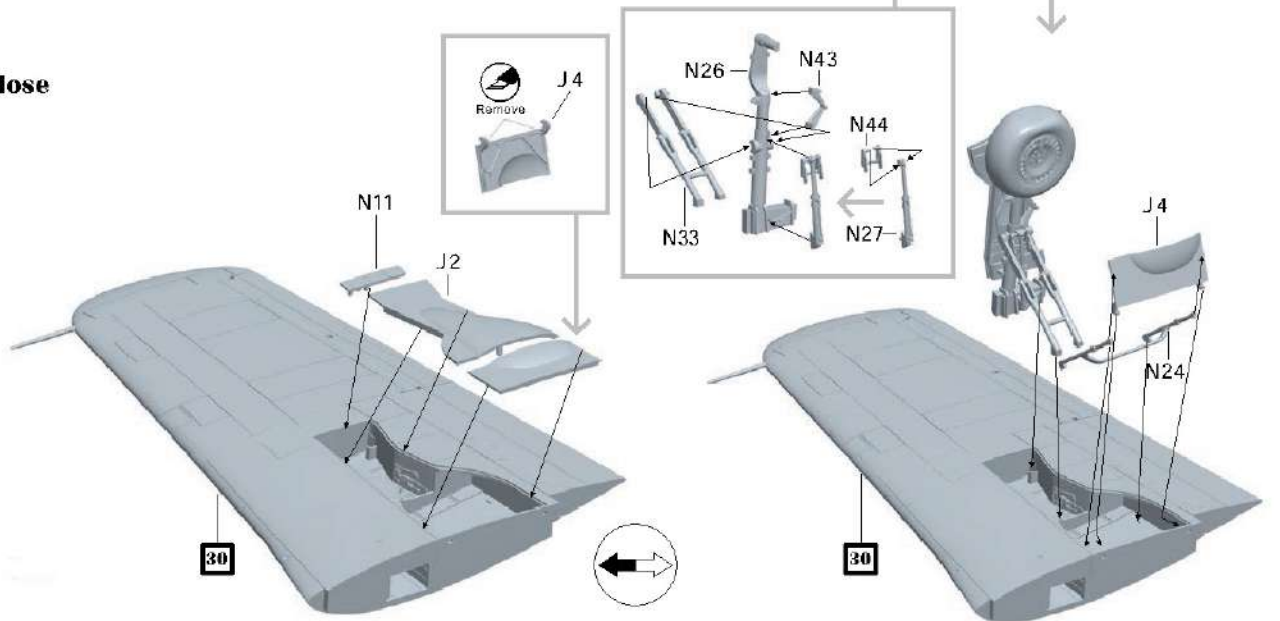

Open

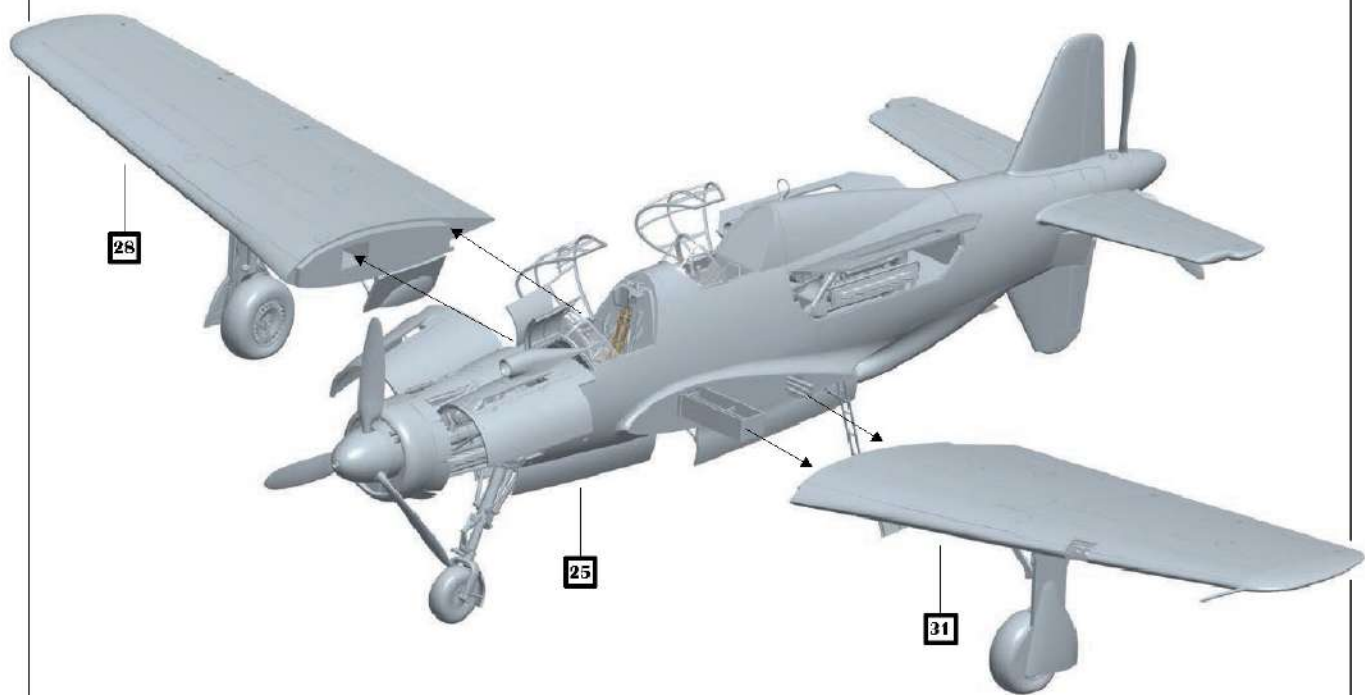

Close



33

Open



Close



# Parts

(A) PART

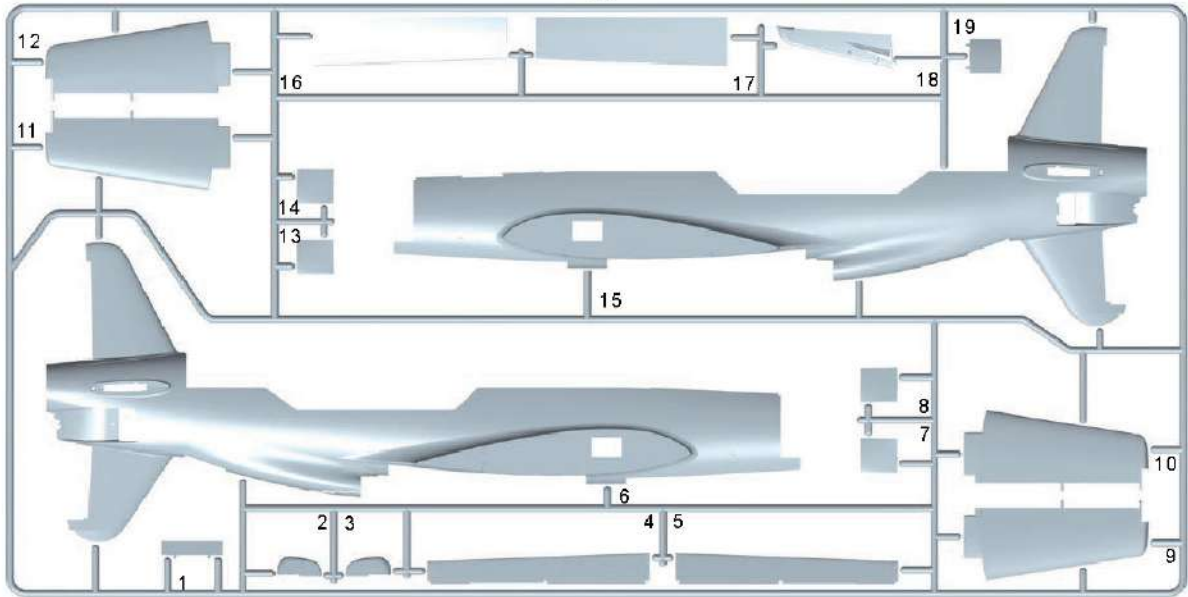

(B) PART

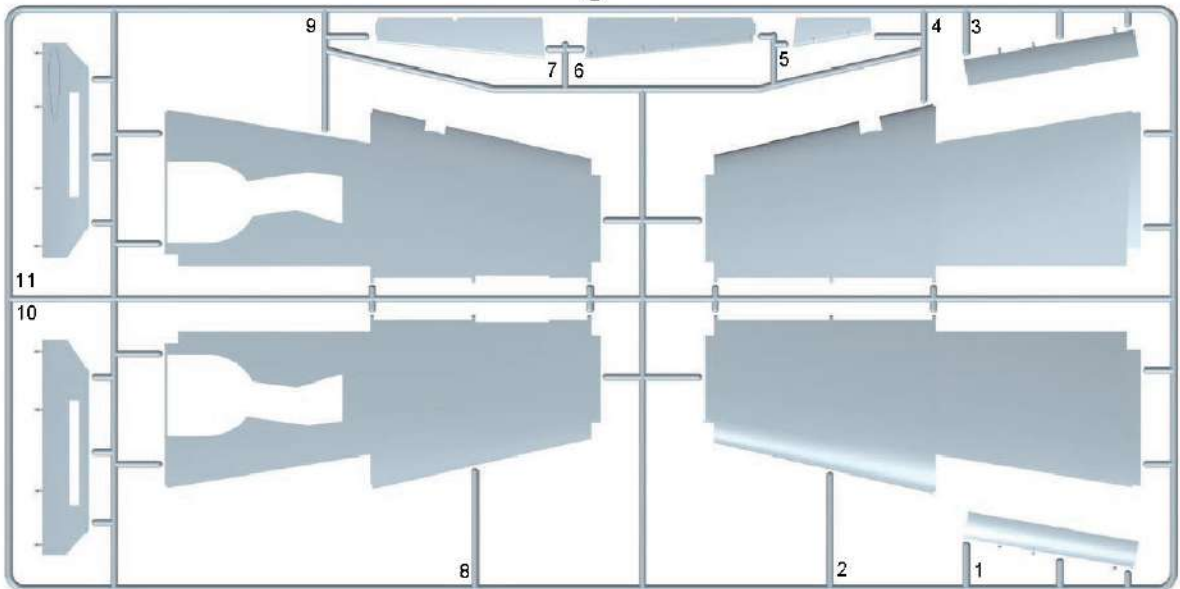

# Parts

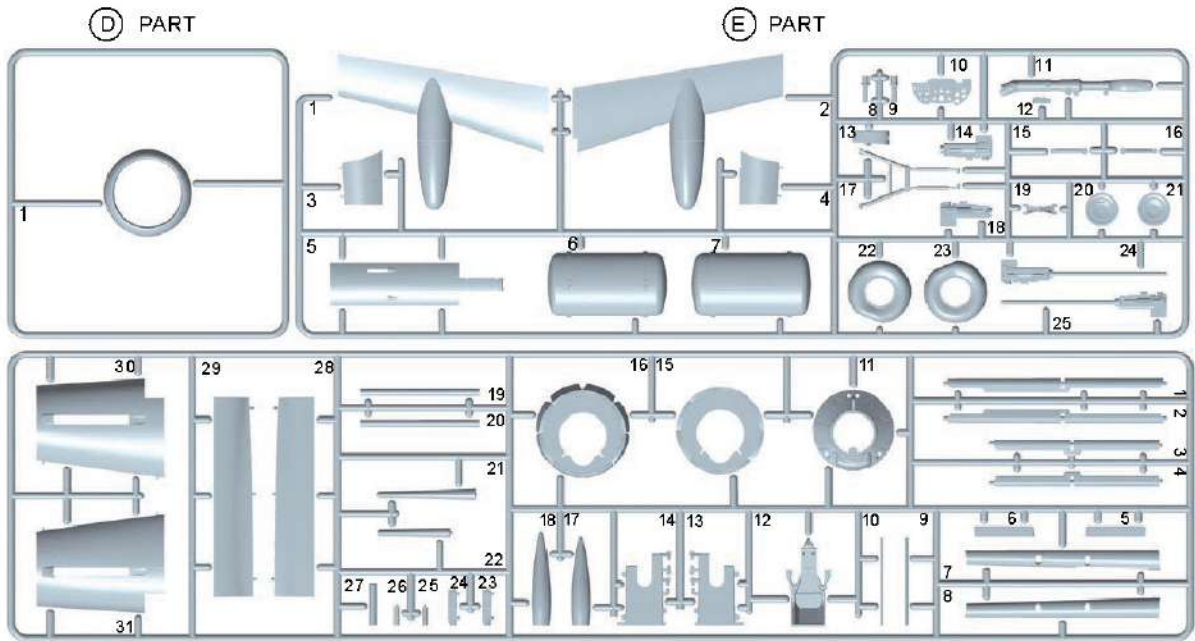

**(C) PART**

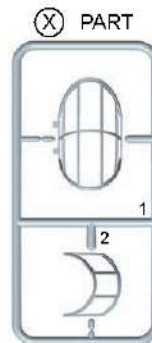
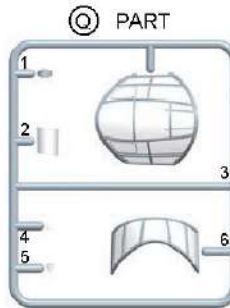
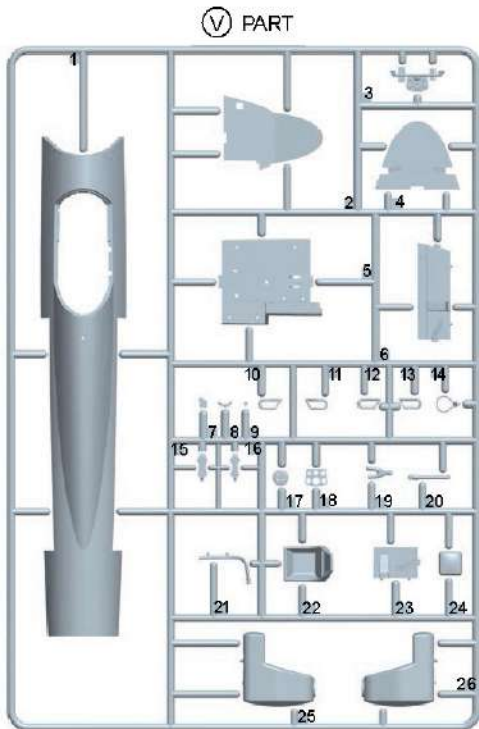

PE x 2

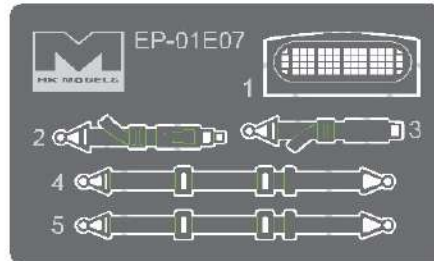

# Parts

(M) PART

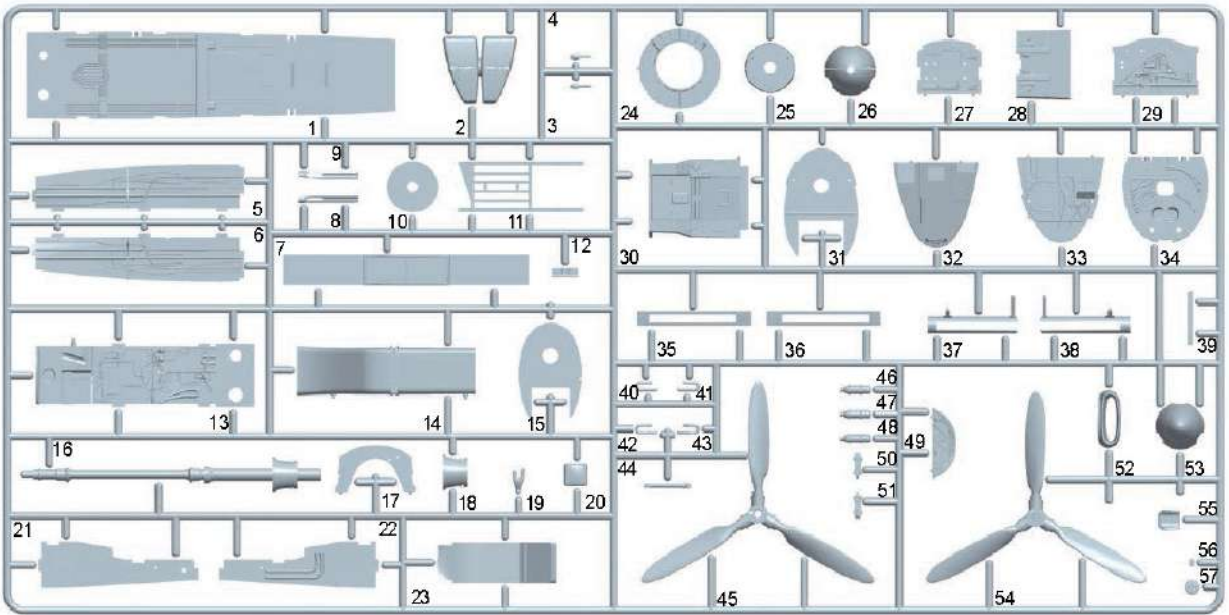

(P) PART X2

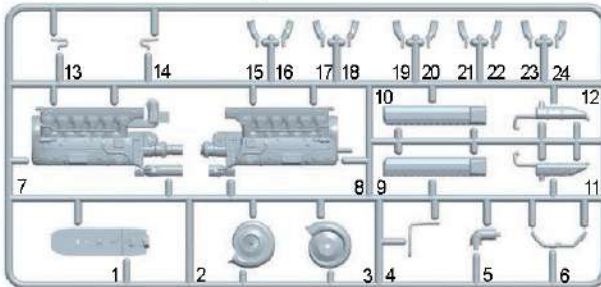

(N) PART

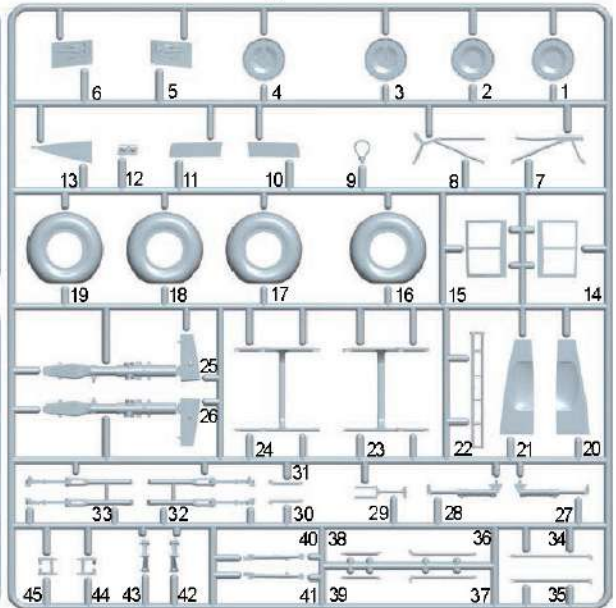

(O) PART

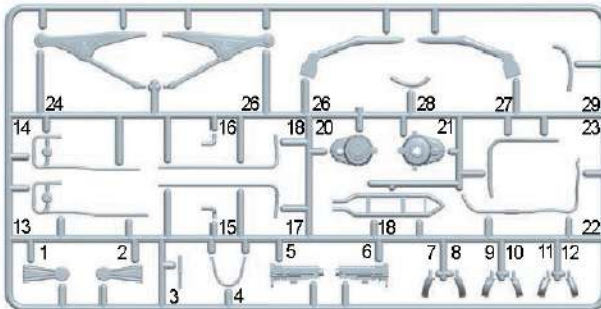

# Parts

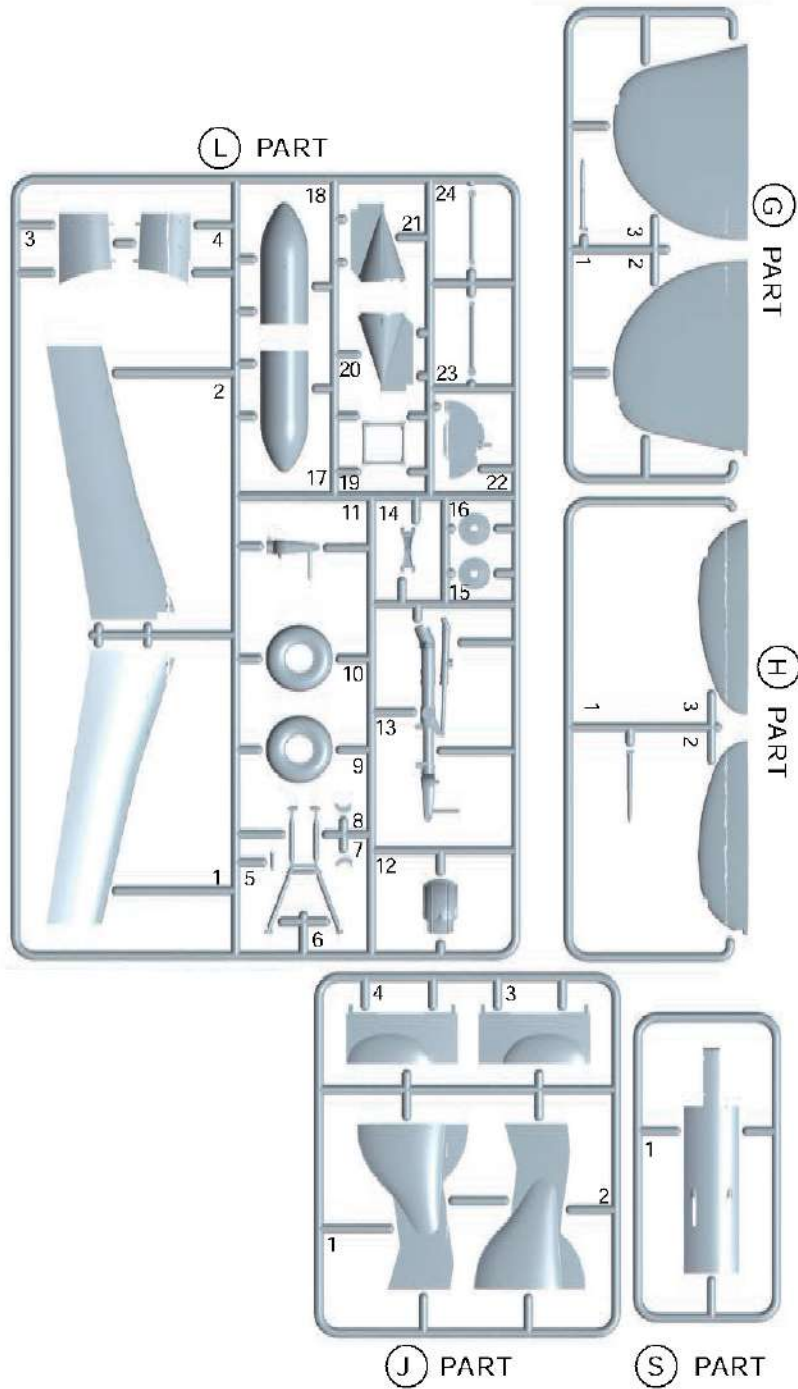



# Decals

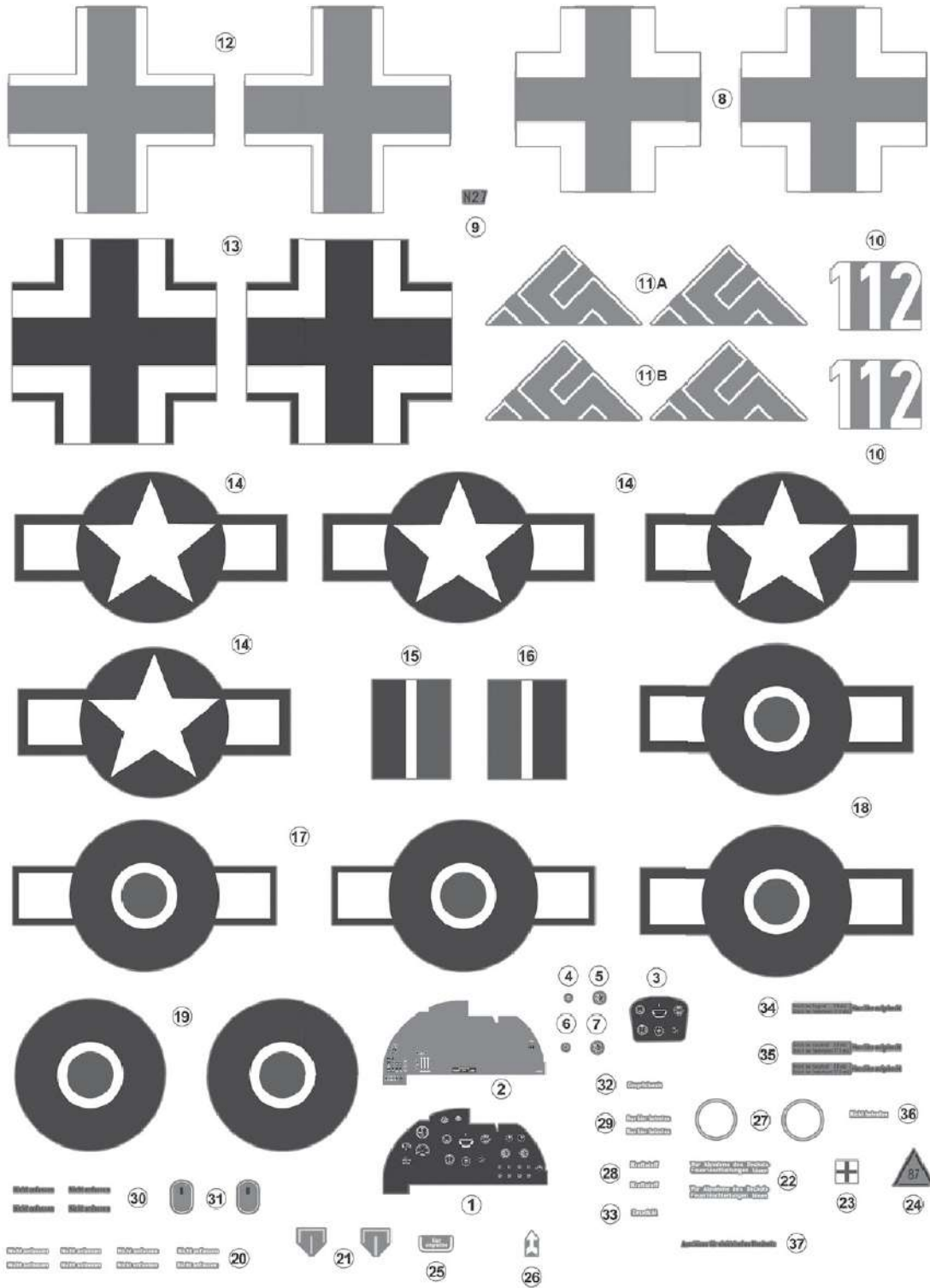

Dornier Do 335 A-10 Trainer HK Models 01E09

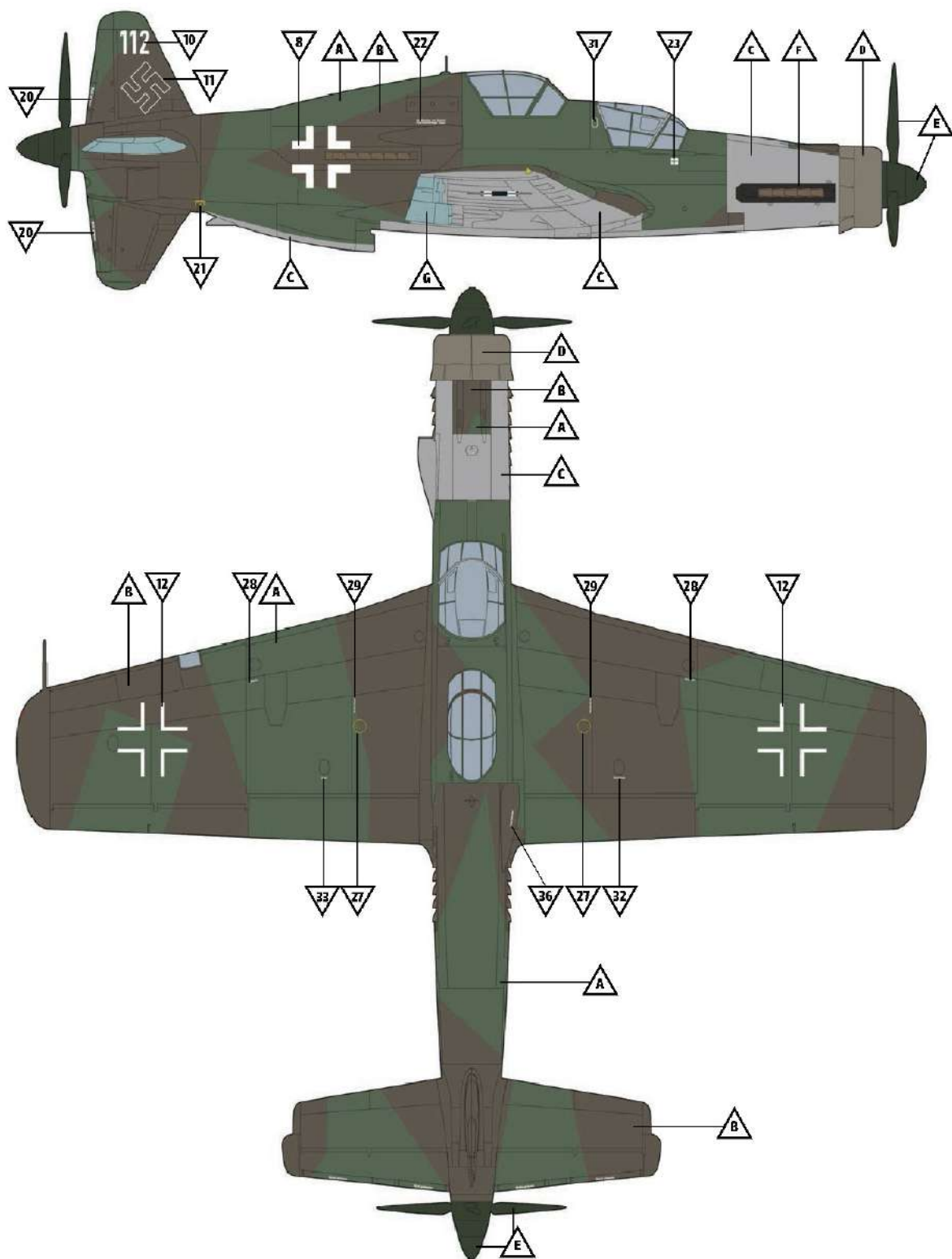

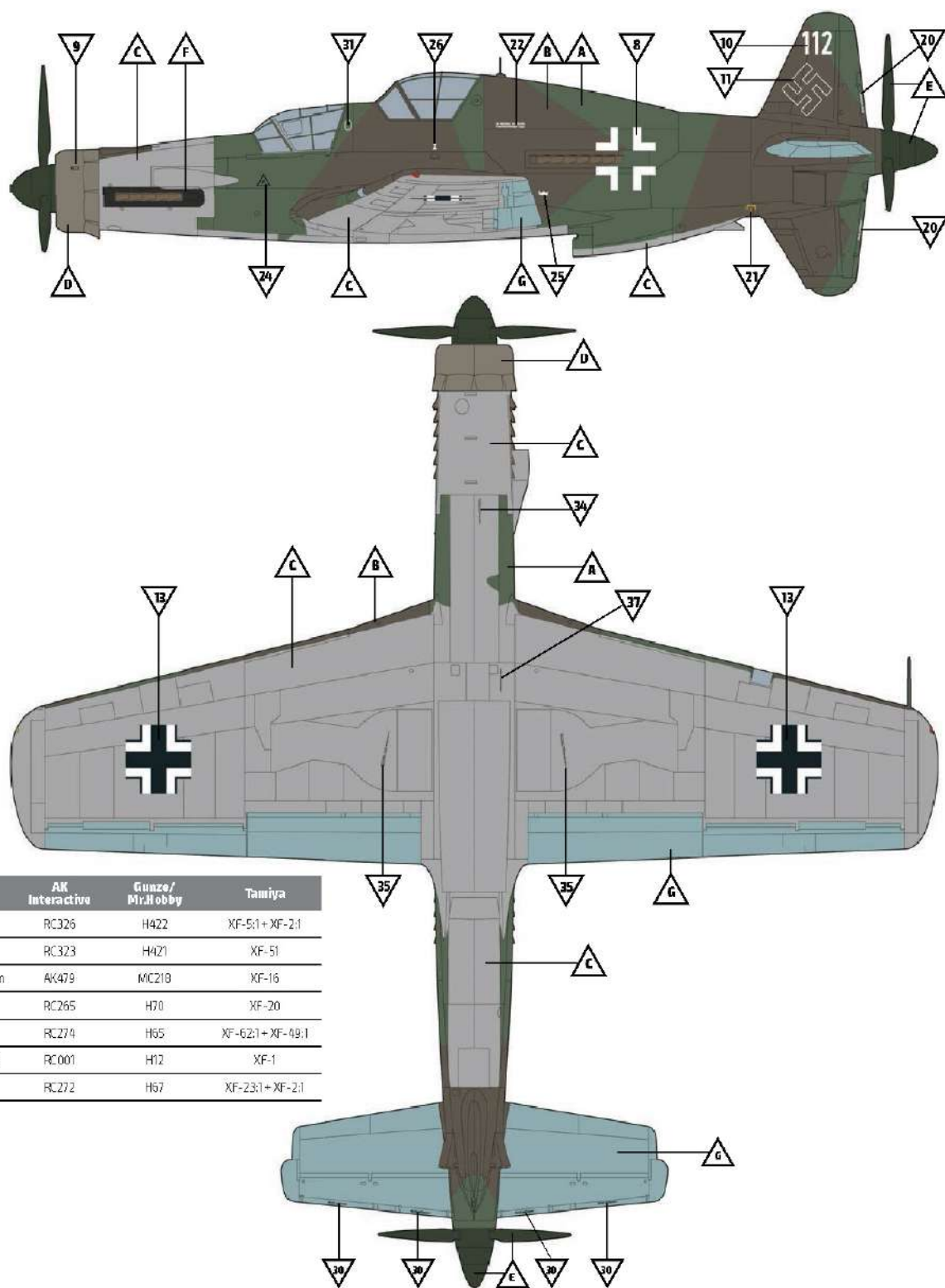

Key	AK Interactive	Gunze/Mr.Hobby	Tamiya
A: RLM 02	RC326	H422	XF-51 + XF-21
B: RLM 01	RC323	H421	XF-51
C: Aluminium	AK479	MC210	XF-16
D: RLM 02	RC265	H70	XF-20
E: RLM 70	RC274	H65	XF-621 + XF-09.1
F: Flat Black	RC001	H12	XF-1
G: RLM 65	RC272	H67	XF-231 + XF-21

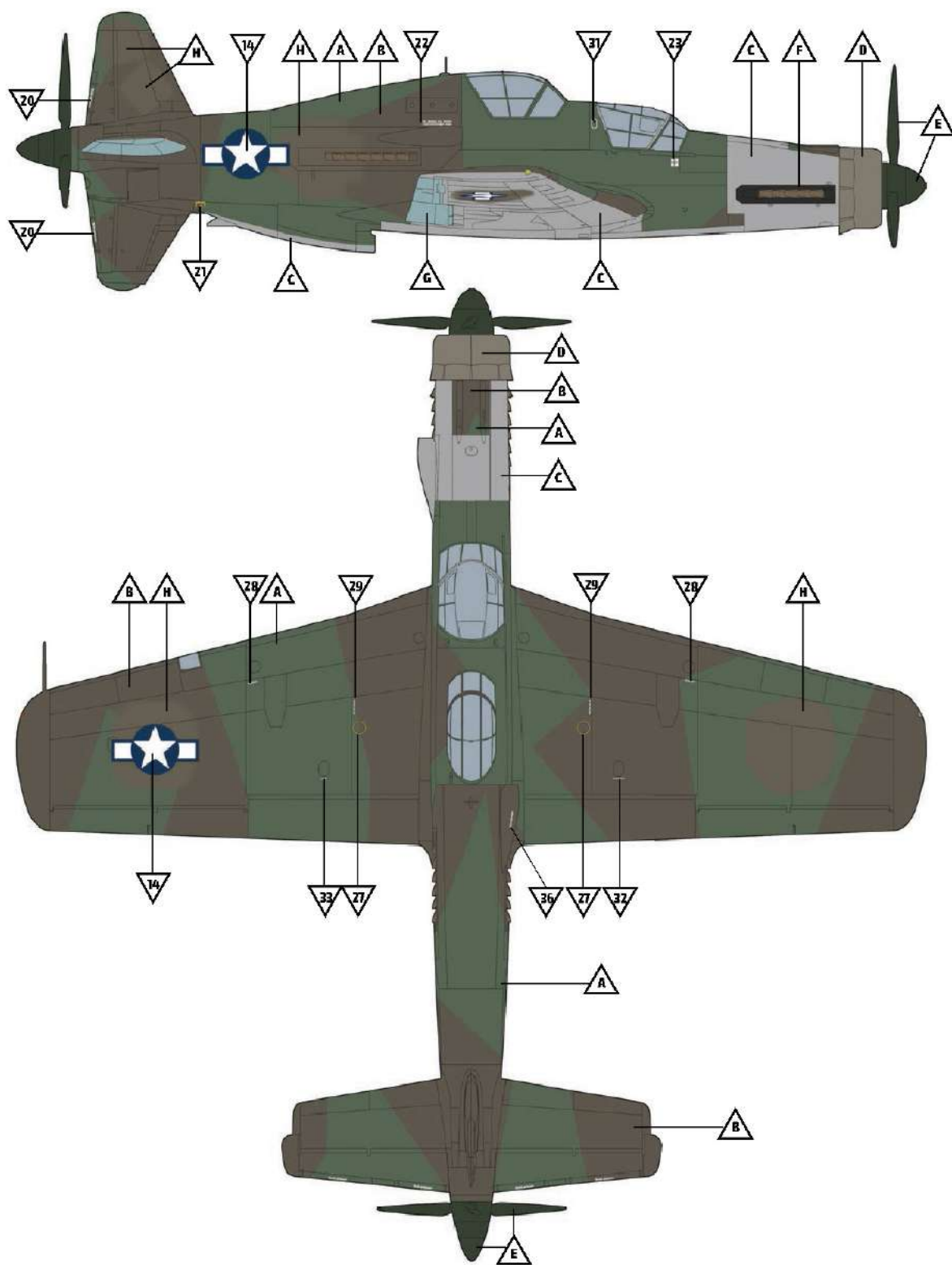

# MARKING

# B

## Dornier Do 335 A-10, WNr. 240112, captured by US, Neubiberg, Germany, April 1945

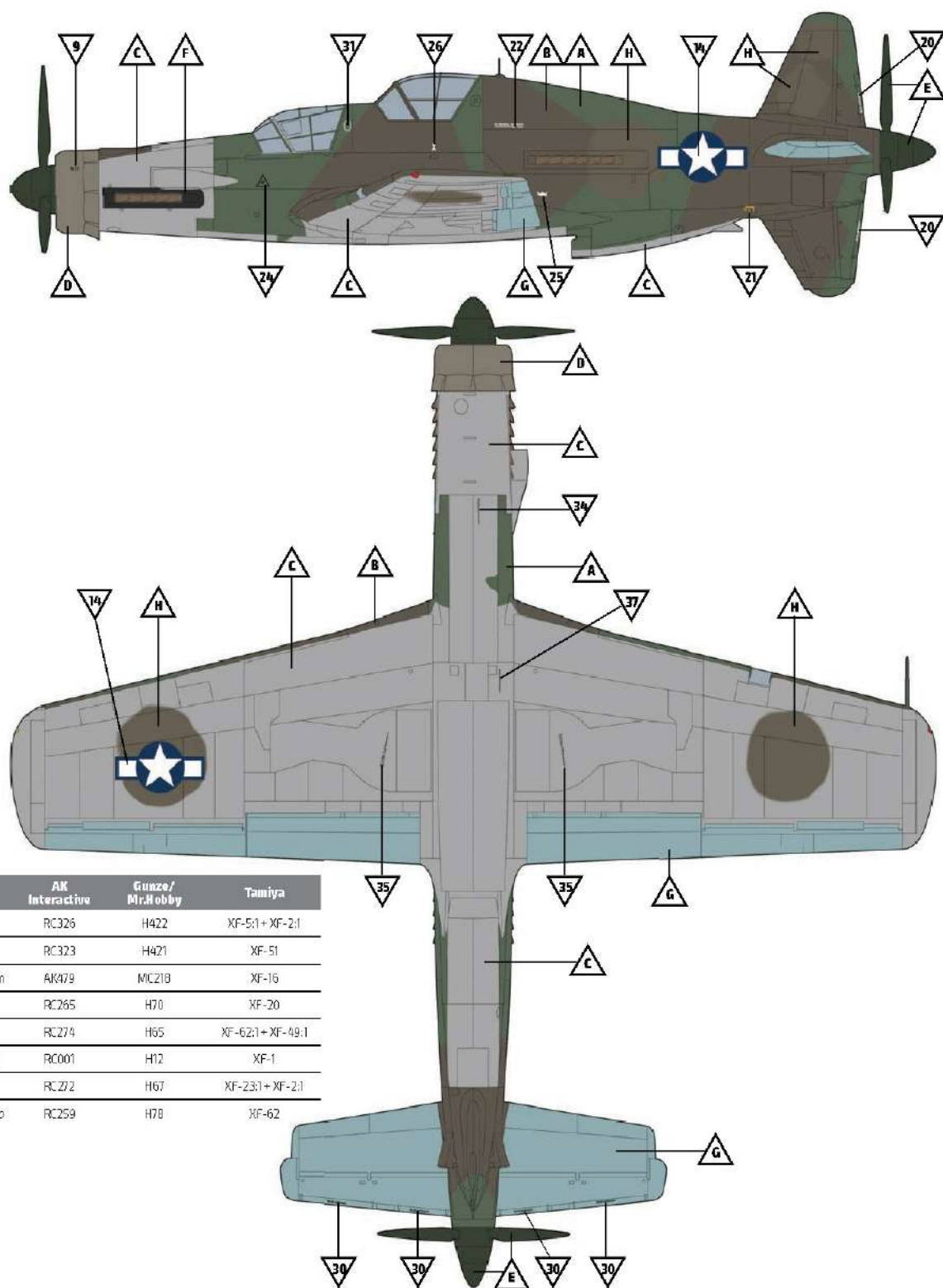

Key	AK Interactive	Gunze/Mr.Hobby	Tamiya
A: RLM 02	RC326	H422	XF-51 + XF-21
B: RLM 01	RC323	H421	XF-51
C: Aluminium	AK979	MC210	XF-16
D: RLM 02	RC265	H70	XF-20
E: RLM 70	RC274	H65	XF-621 + XF-49.1
F: Flat Black	RC001	H12	XF-1
G: RLM 65	RC272	H67	XF-231 + XF-21
H: Olive Drab	RC259	H78	XF-62

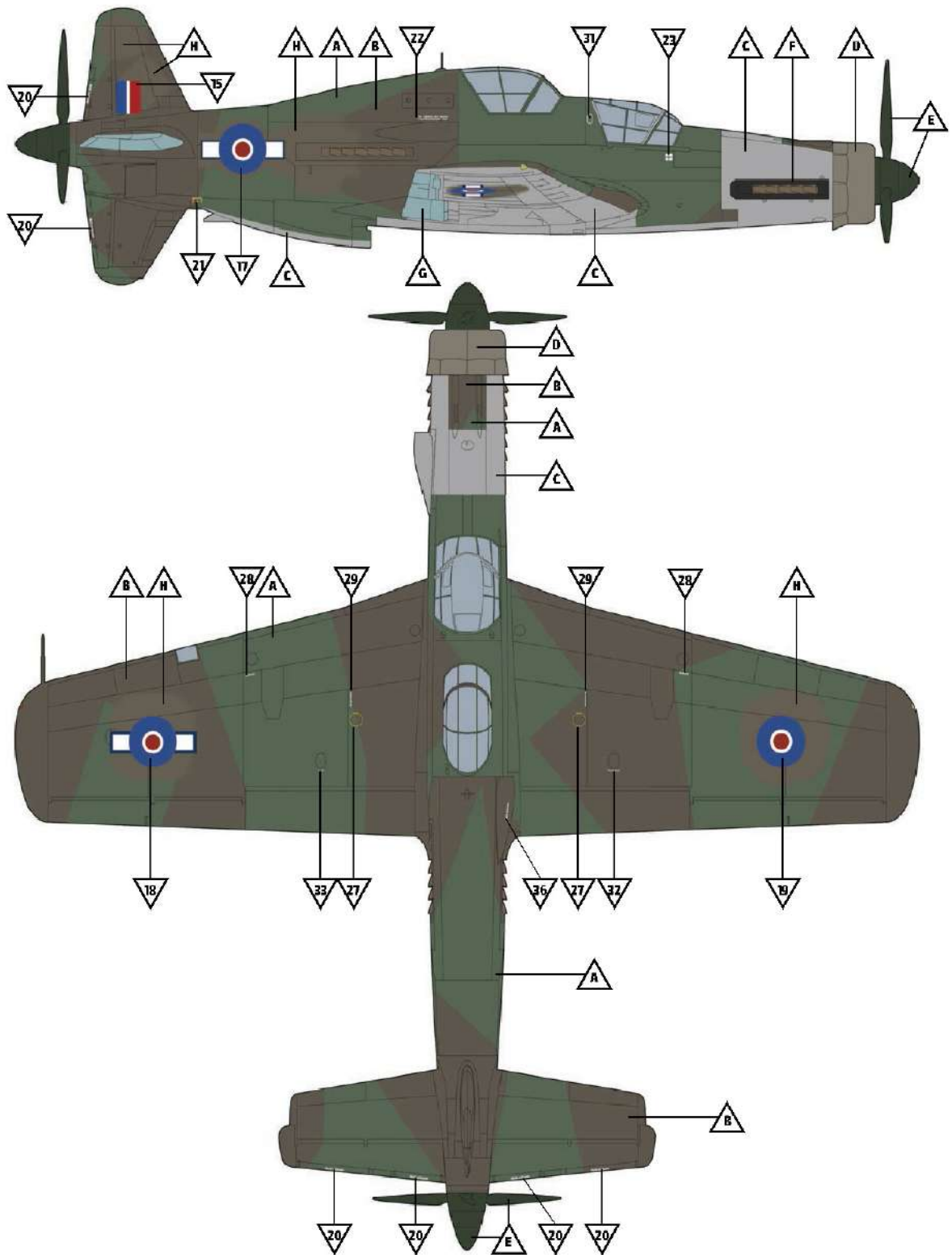

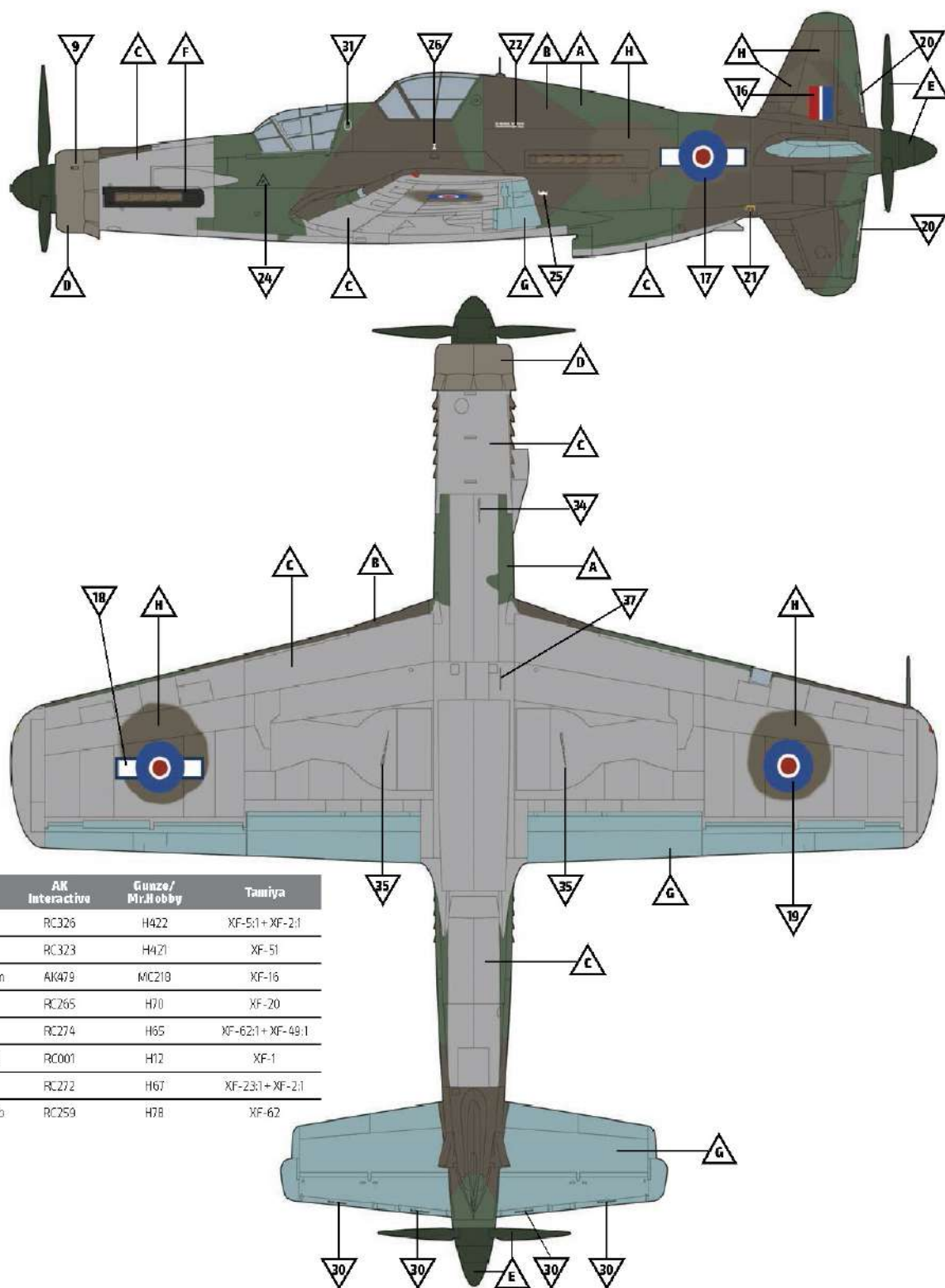

Key	AK Interactive	Gunze/Mr.Hobby	Tamiya
A: RLM 02	RC326	H422	XF-51 + XF-21
B: RLM 01	RC323	H421	XF-51
C: Aluminium	AK479	MC210	XF-16
D: RLM 02	RC265	H70	XF-20
E: RLM 70	RC274	H65	XF-62:1 + XF-49:1
F: Flat Black	RC001	H12	XF-1
G: RLM 65	RC272	H67	XF-23:1 + XF-2:1
H: Olive Drab	RC259	H78	XF-62

## Colour Guide

Key	Gunze/Mr.Hobby	Tamiya	AK Interactive
A: RLM 81 Brown Violet	H421	XF-51:1 + XF-64:2	AK2026
B: RLM 82 Light Green	H422	XF-5:1 + XF-2:1	AK2027
C: RLM 65 Light Blue	H67	XF-23:1 + XF-2:1	AK2003
D: RLM 70 Black Green	H65	XF-62:1 + XF-49:1	AK2005
E: RLM 66 Black Grey	H416	XF-63	AK2004
F: RLM 02 Gray	H70	XF-22:1 + XF-49:1	AK2002
G: Flat Black	H12	XF-1	AK735
H: Semi-Gloss Black	H2	X-18	AK719
I: Aluminium	MC218	XF-16	AK479
J: Gun Metal	H76	X-10	AK483
K: Metallic Grey	-	XF-56	AK485
L: Leather	H37	XF-10	AK710
M: Tire Black	H77	XF-69	AK720
N: Dark Grey	H305	XF-24	AK2008
O: Blue	H25	X-14	AK2017
P: Beige	H27	XF-57	AK724
Q: US Olive Drab	H52	XF-62	AK133

In cooperation with:



[www.ak-interactive.com](http://www.ak-interactive.com)



Large  
Scale  
Modeller

[www.largescalemodeller.com](http://www.largescalemodeller.com)

General kit help/reference: **Large Scale Modeller**  
Illustration, manual layout and format: **HK Models & AK-Interactive**  
Manual and assistance: **AK-Interactive**  
Introductory text: **Cees Broere**