



Supermarine Spitfire Mk.IIA w/Rotol Propeller

32002



-  OPEN HOLE
FORO APERTO
OFFEN
HACER AQUJERO
WYKONAĆ OTWÓR
FAIRE UN TROU
VYVRTAT OTVOR
-  DECAL
DECALCOMANIE
ABZIEHBILD
CALCOMANIA
KALKOMANIA
DECALCOMANIE
OBTISK
-  REMOVE
RETIRER
ENTFERNEN
CORTAR
WYCIĄC
SEPARARE
ODSTRANIT
-  OPTION
FACULTATIF
NACH BELIEBEN
HACER AQUJERO
DO WYBORU
FACULTATIVO
VOLBA
-  FILL HOLE
FORO PIENO
NE PAS COLLER
NICHT KLEBEN
NO PEGAR
NIE SKLEJAC
NON INCOLLARE
NELEPIT
-  DO NOT CEMENT
NE PAS COLLER
NICHT KLEBEN
NO PEGAR
NIE SKLEJAC
NON INCOLLARE
NELEPIT
-  CA GLUE
COLLA CA
CA KLEBER
PEGAMENTO CA
COLLE CA
COLLE CA
CA LEPIDLO
-  DRILL HOLE
TROU DE FORAGE
BOHRLOCH
TALADRO
WYWIERC OTWÓR
FORO
VYVRTAT DÍRU

Color Chart	AK Interactive	Alclad2	AMMO	FATSKA	Mr. COLOR	Revell	TAMIYA	
RAF Dark Green	A	RC286	E013	915	016	361	68	XF-81
RAF Dark Earth	B	RC287	E021	072	009	369	82	XF-52
RAF Sky	C	RC290	E011	242	022	368	59	XF-21
RAF Ocean Grey	D	RC288	E004	245	032	362	77	XF-82
RAF Medium Sea Gray	E	RC289	E003	246	141	335	43	XF-83
RAF Night FS37030	F	RC082	E620	907	041		09	XF-69
RAF Interior Green	G	RC293	E309	226	211	027		XF-71
Flat White	H	RC004	101	050	101	062	05	XF-2
Flat Black	I	RC001	2102	46	100	033	08	XF-1
Silver	J	RC020	112	195	189	008	90	X-11
Burnt Metal	K	RC015	121	187	016	061		XF-84
Leather	L	AK-203	302	133	186	044	37	XF-10
Aluminium	M	RC020	112	194	078	090	99	XF-16
Flat Yellow	N	RC007	E-06	048	107	004	15	XF-8
Tyre Black	O	RC012	1310	033		137	06	XF-69
Flat Red	P	RC006	F6/5	049	103	033	330	X-7
Clear Red	Q	RC 503	401	093	CC02	047	31	X-27
Clear Green	R	RC505	404	092		138		X-25

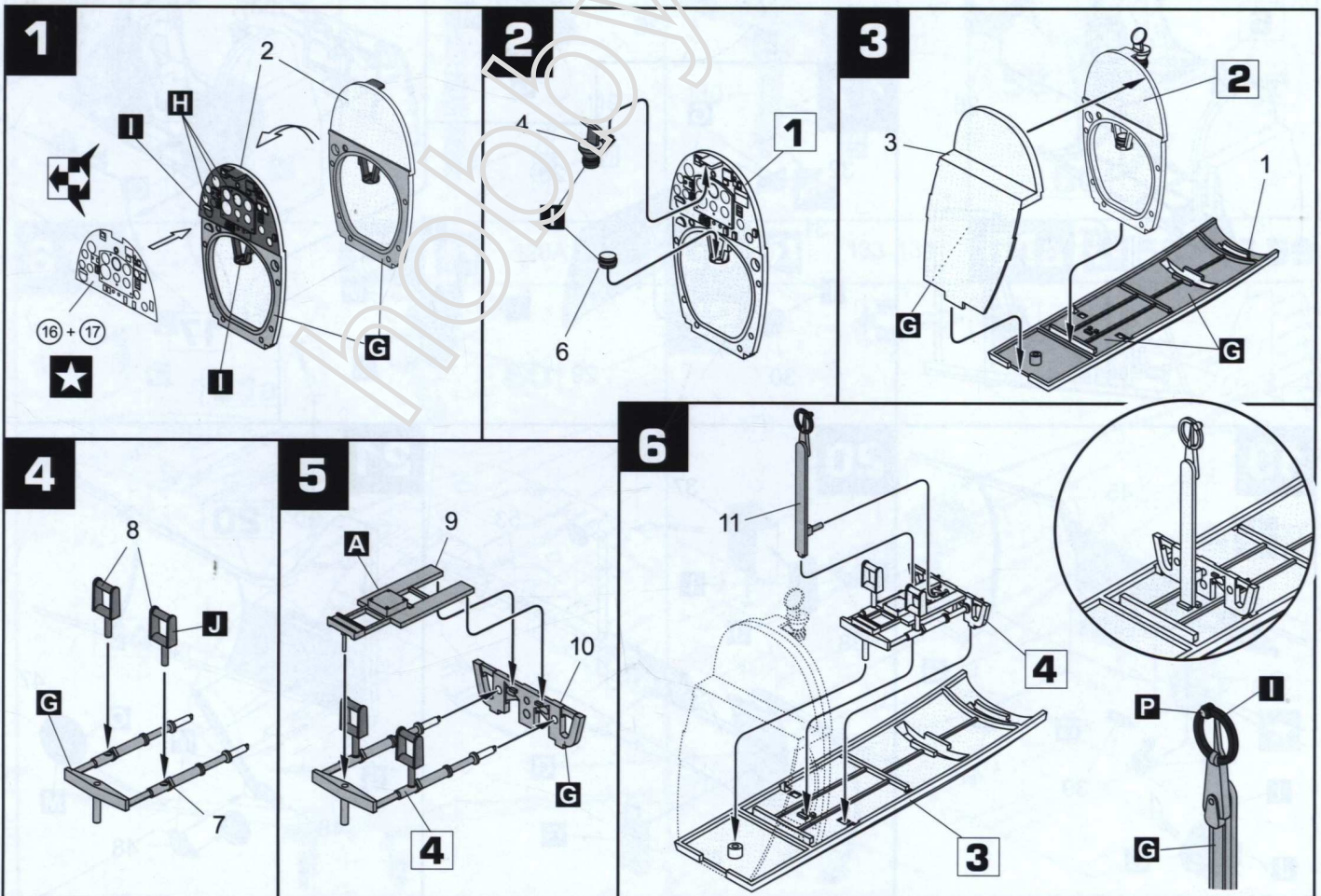

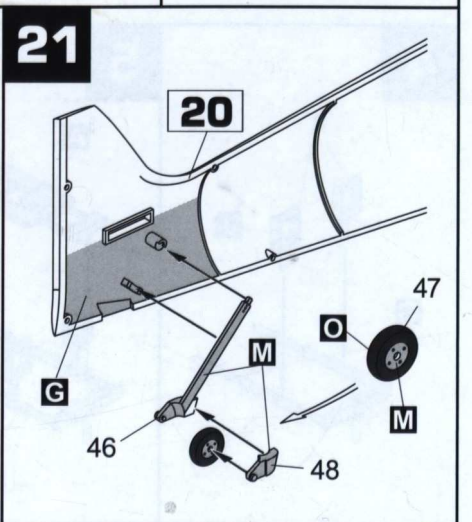
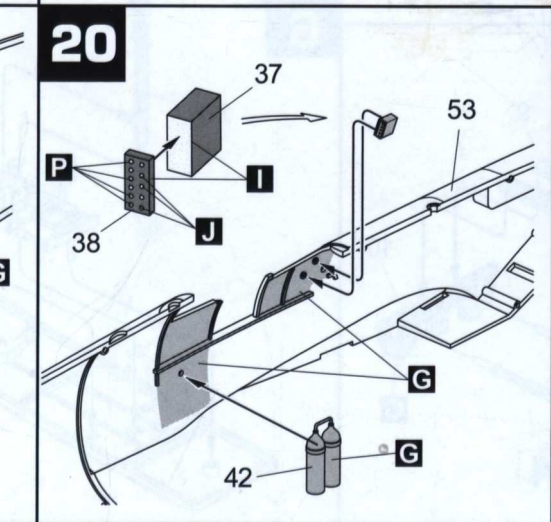
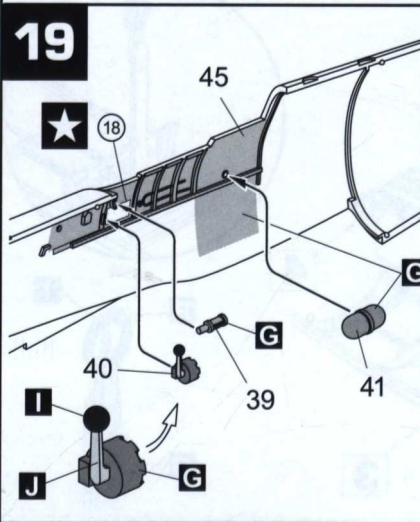
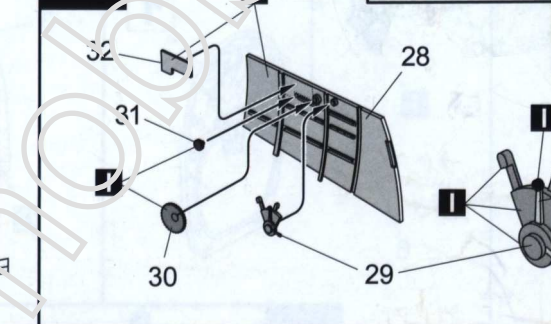
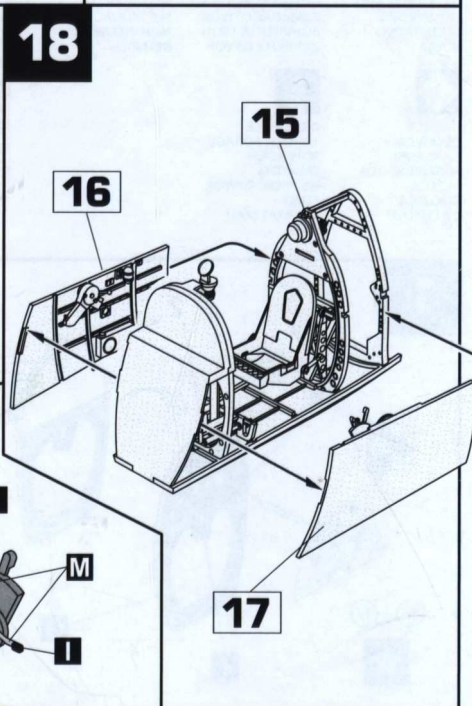
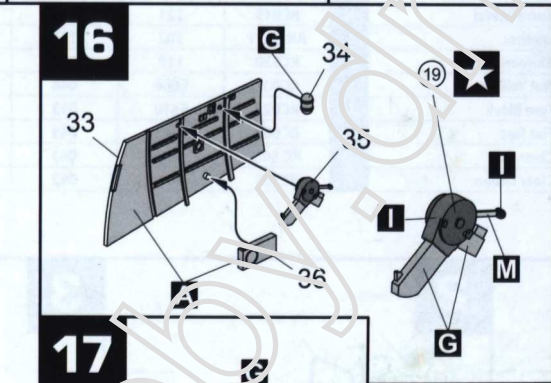
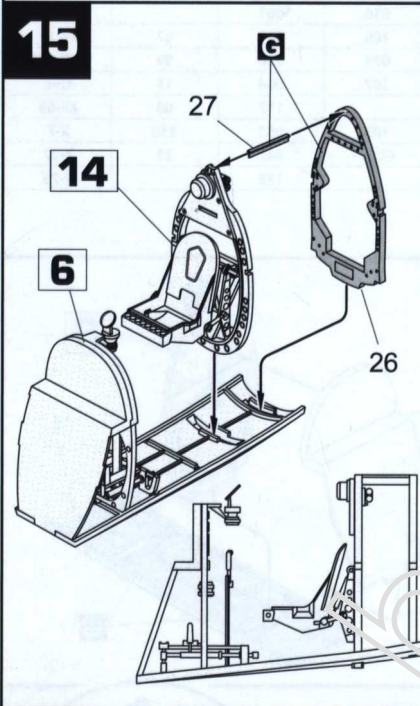
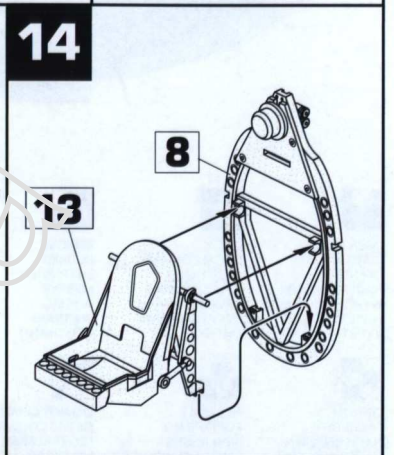
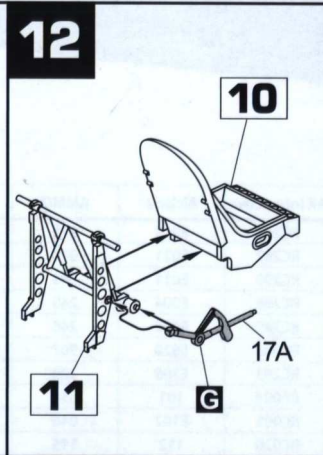
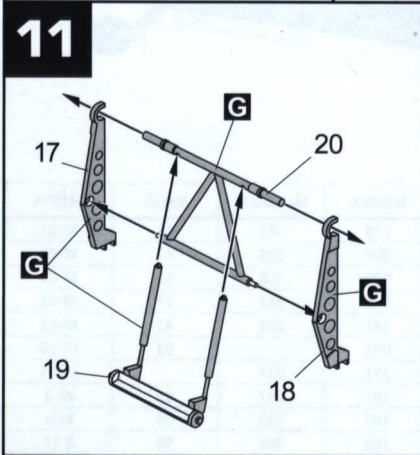
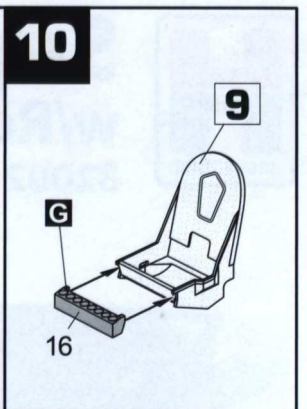
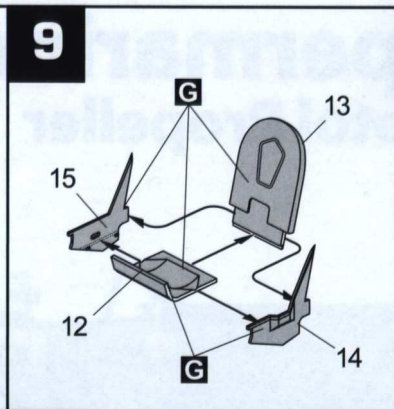
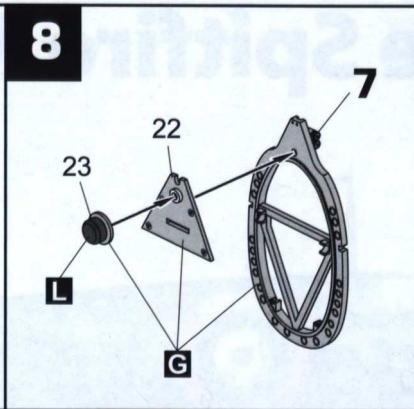
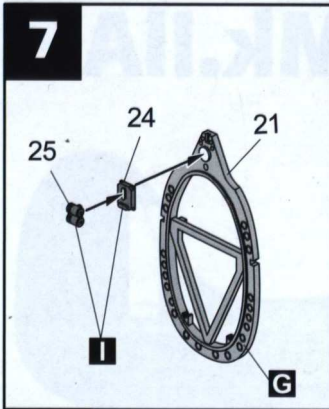

22

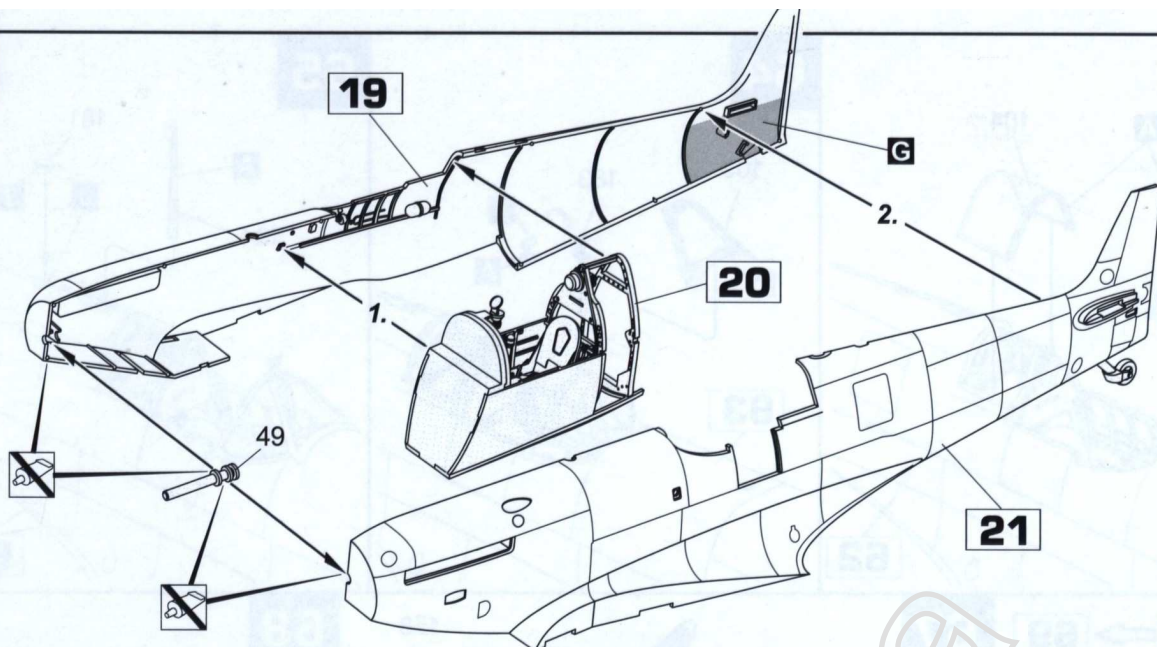

24

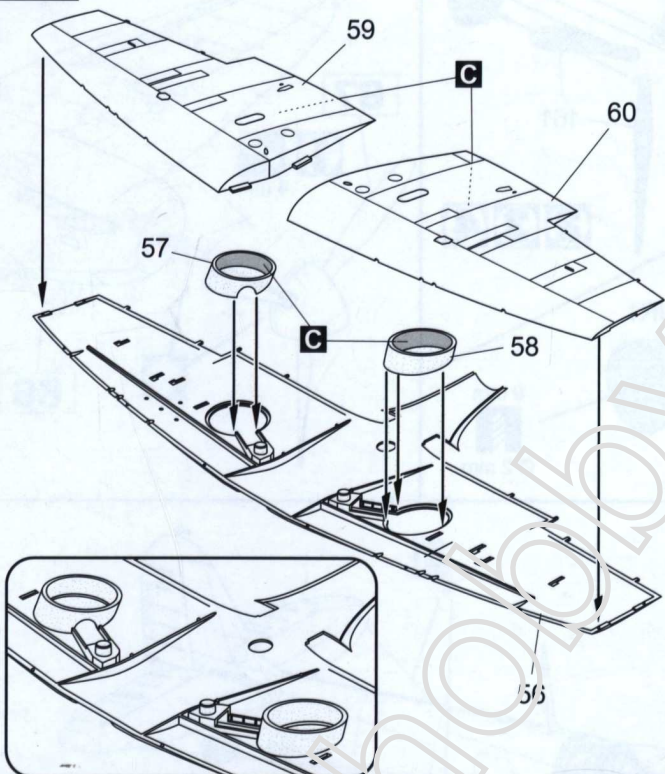

25

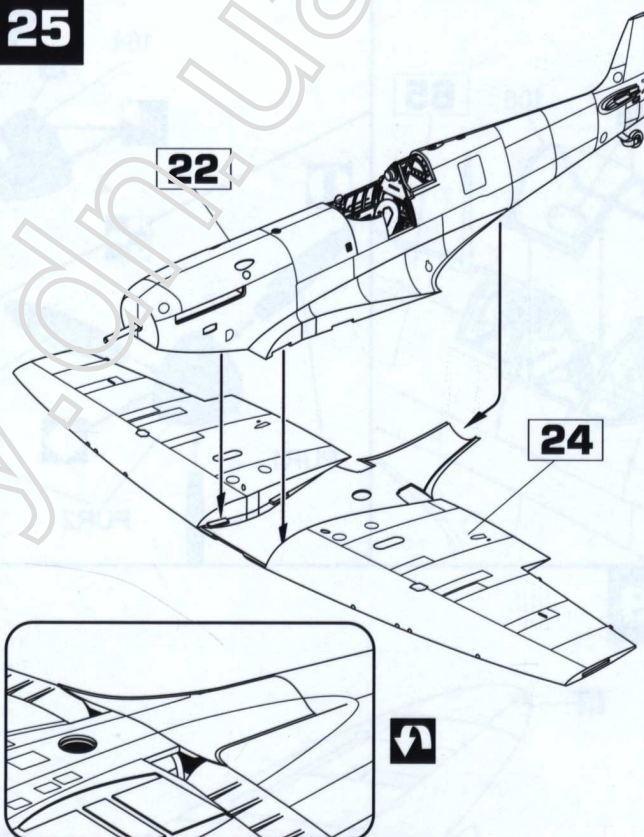

26

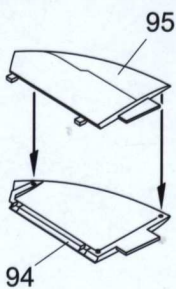

28

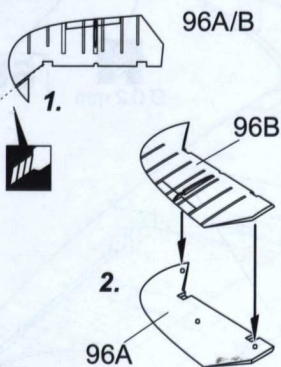

30

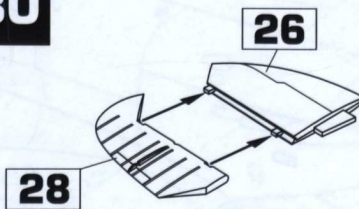

32

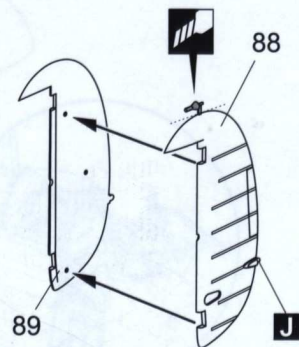

27

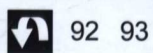

29

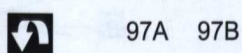

31

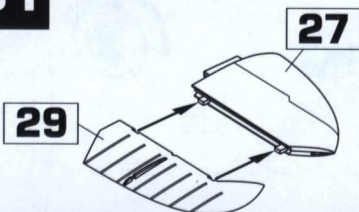

33

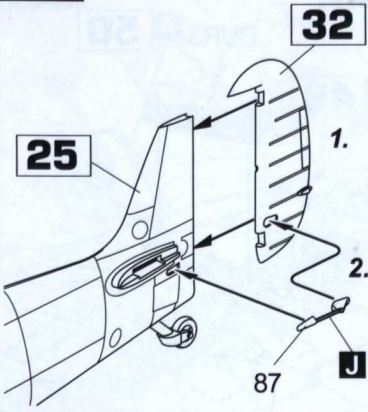

34

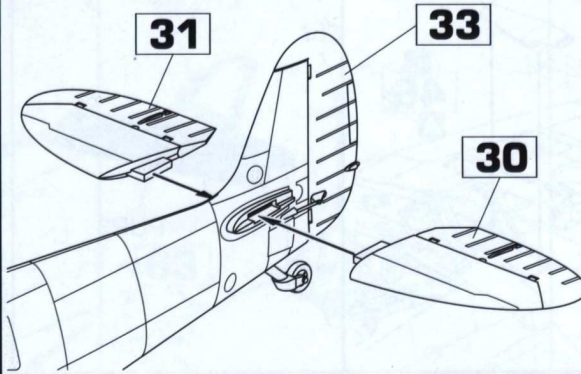

35



36

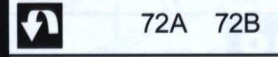

37

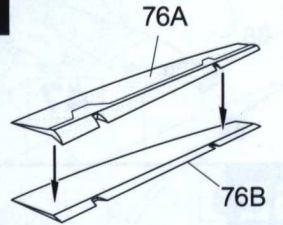

39

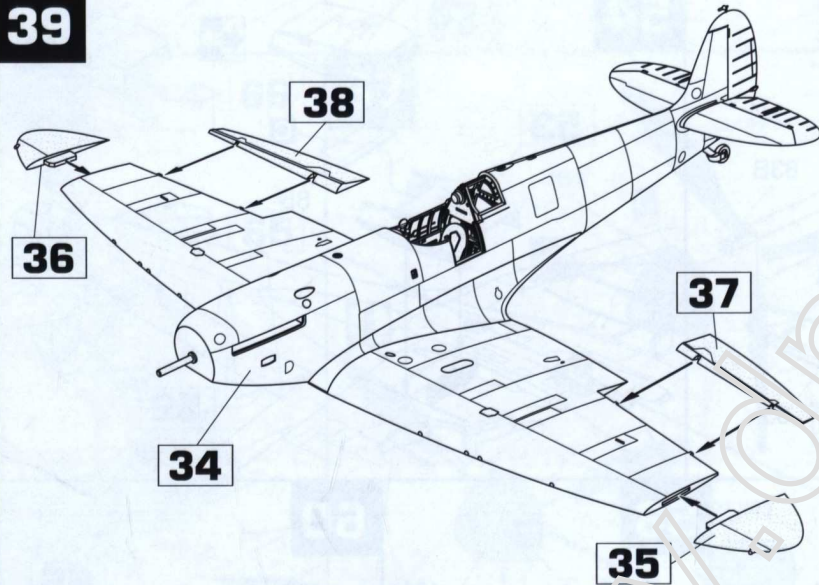

40

38

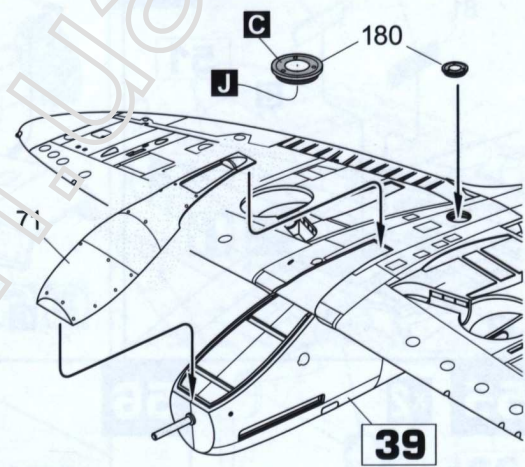
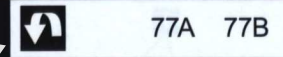

41

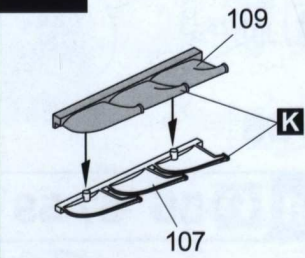

43

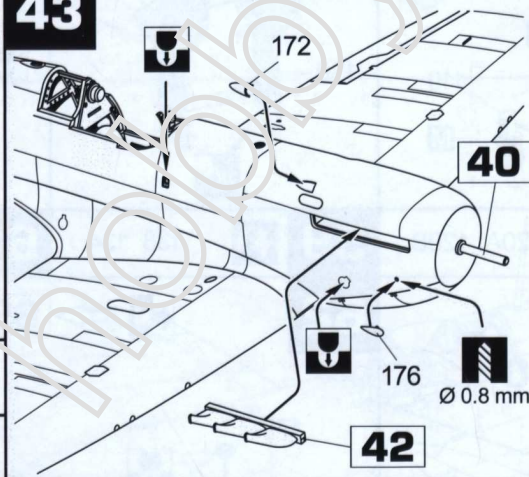

44

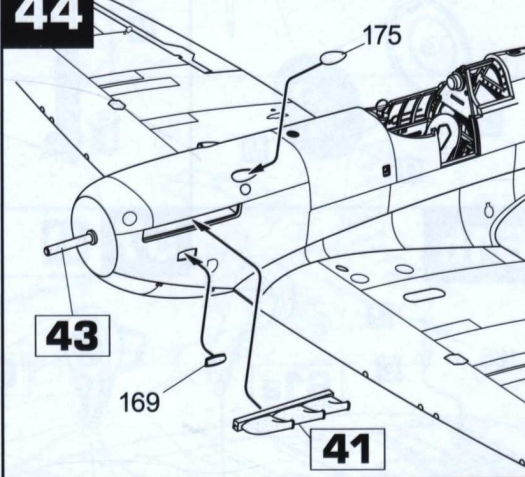

42

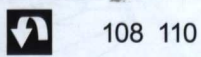

45

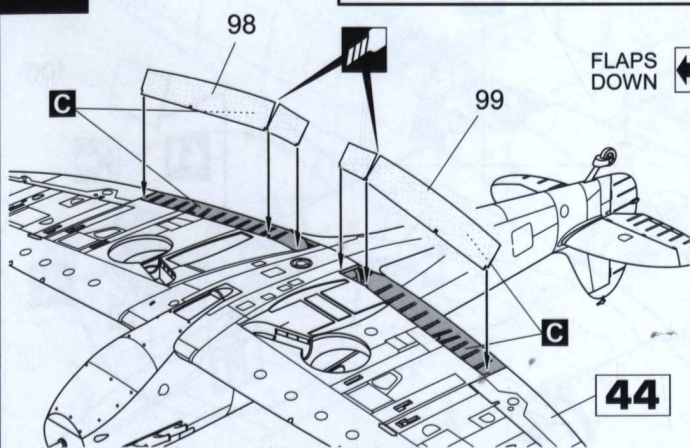

FLAPS DOWN FLAPS UP

46

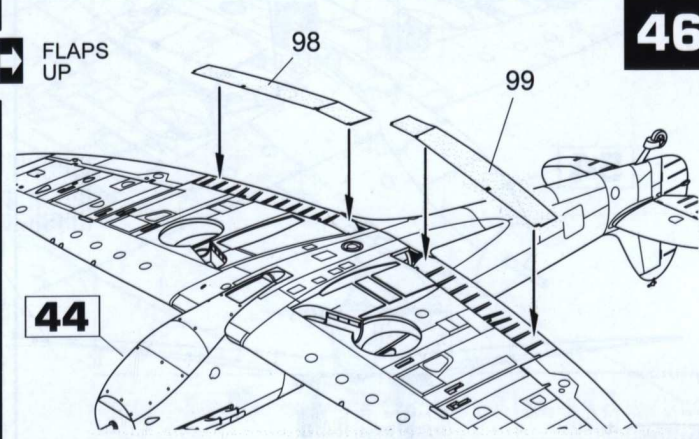

63

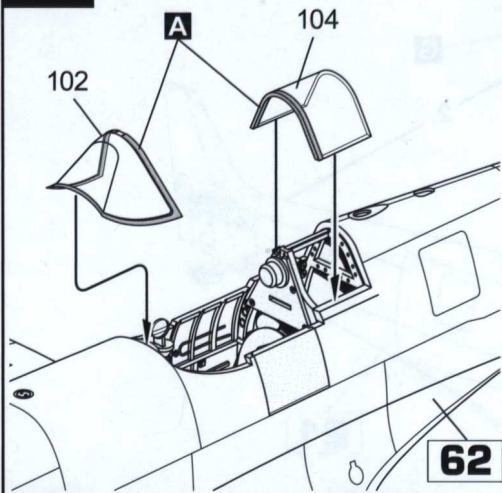

64

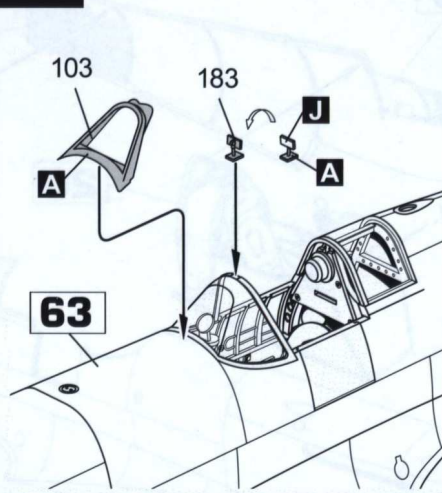

65

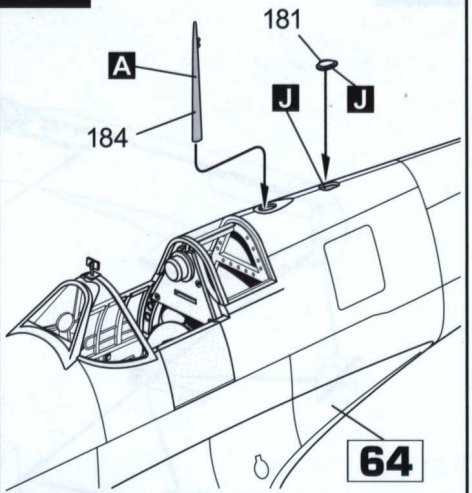

66

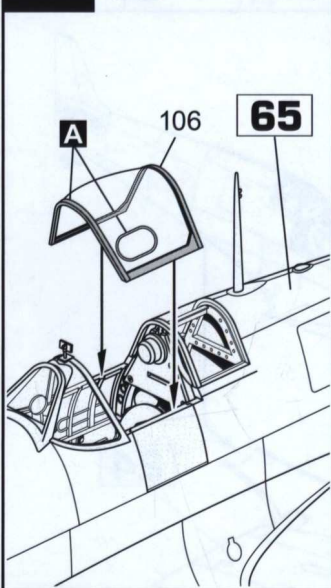
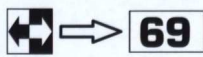

67

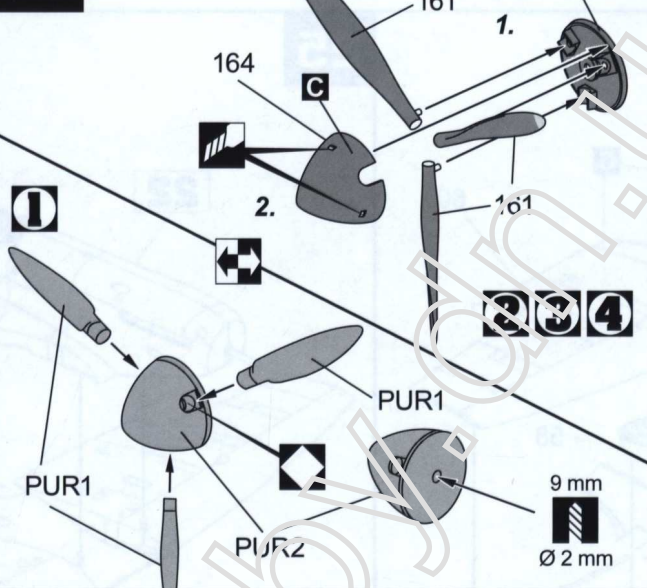

68

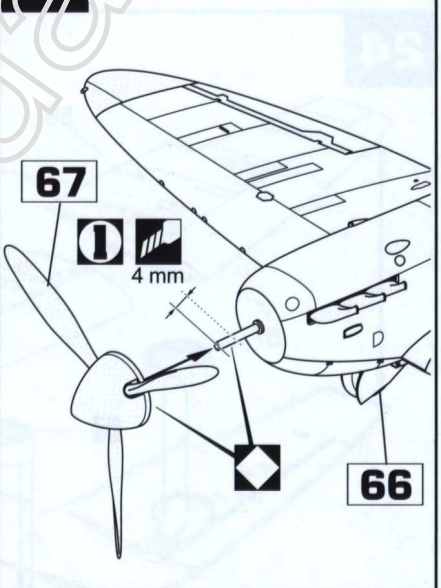

69

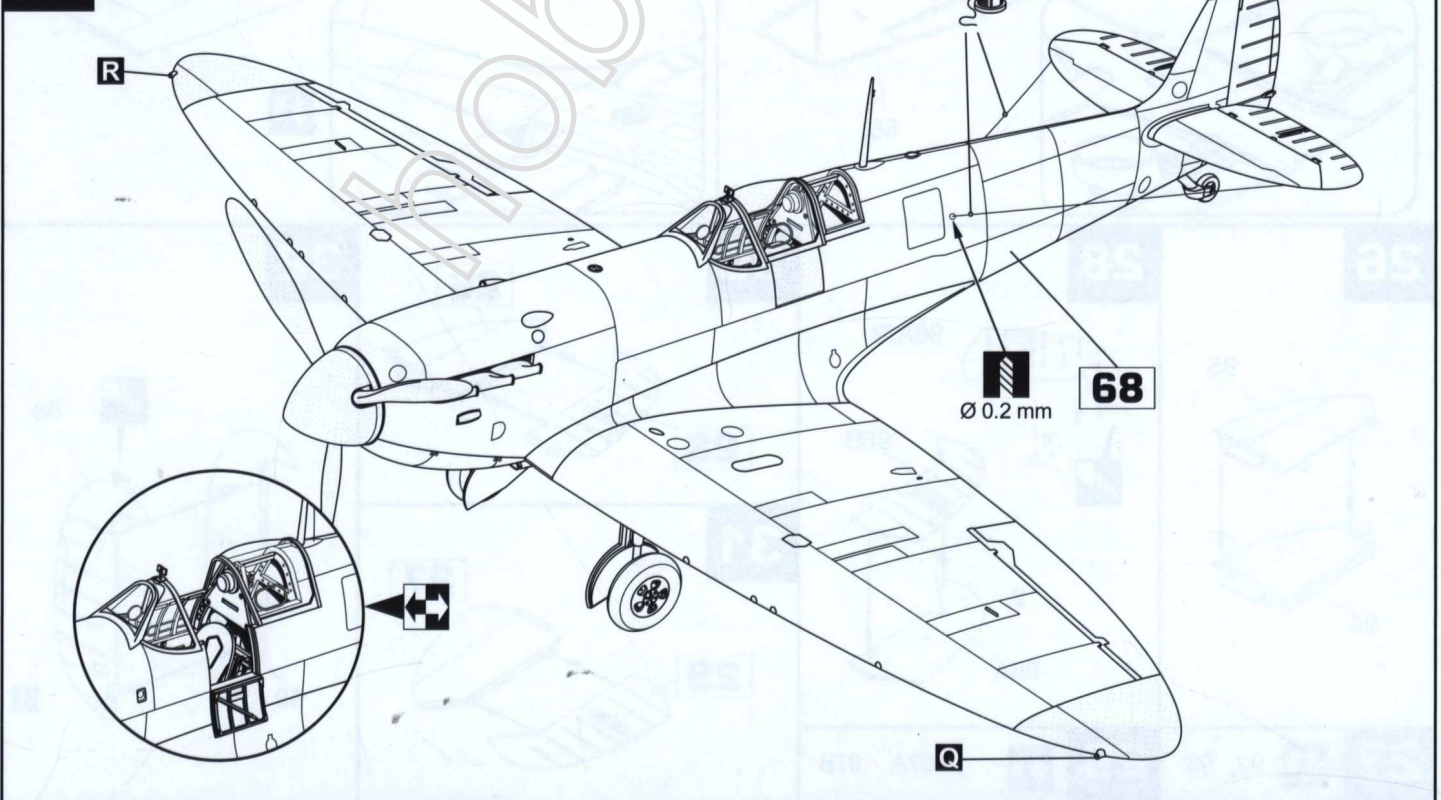

1:32 Supermarine Spitfire IA, IIA, VA parts list

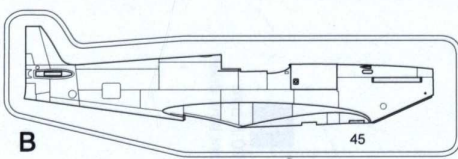

B

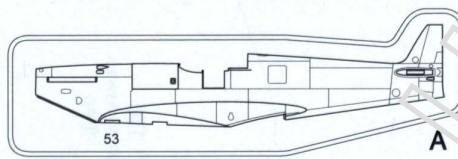

A

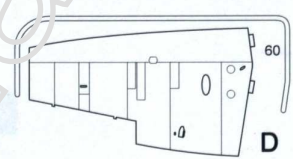

D

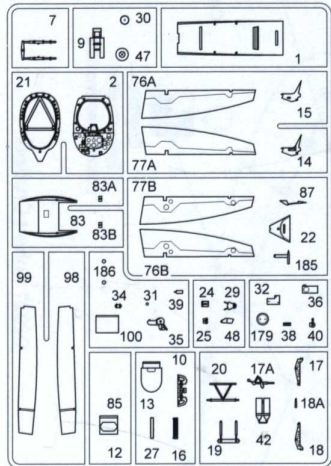

F

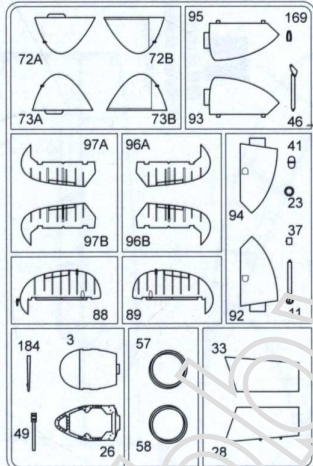

G

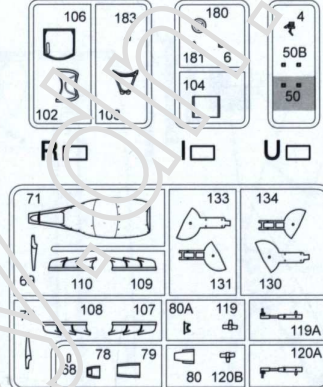

Q

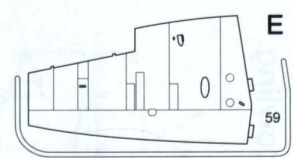

E

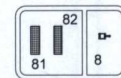

HX2

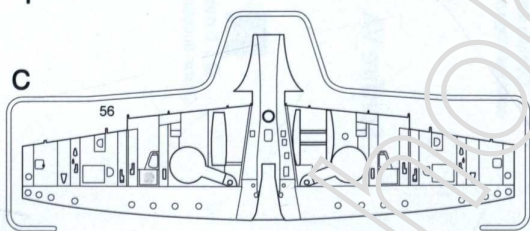

C



T

SX2

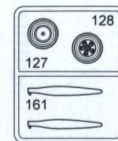

PUR1 PUR2 PUR3

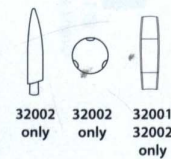

Painting Mask Set

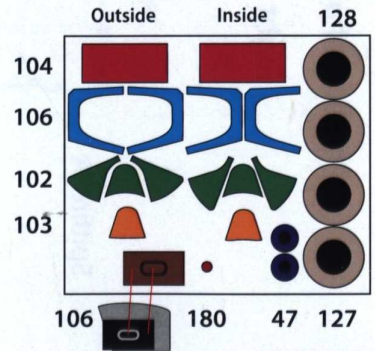

©2021 Hobby 2000

3

Spitfire IIA D-B, P7966, OC Tangmere Wing,
W/Cdr Douglas Bader,
March 1941

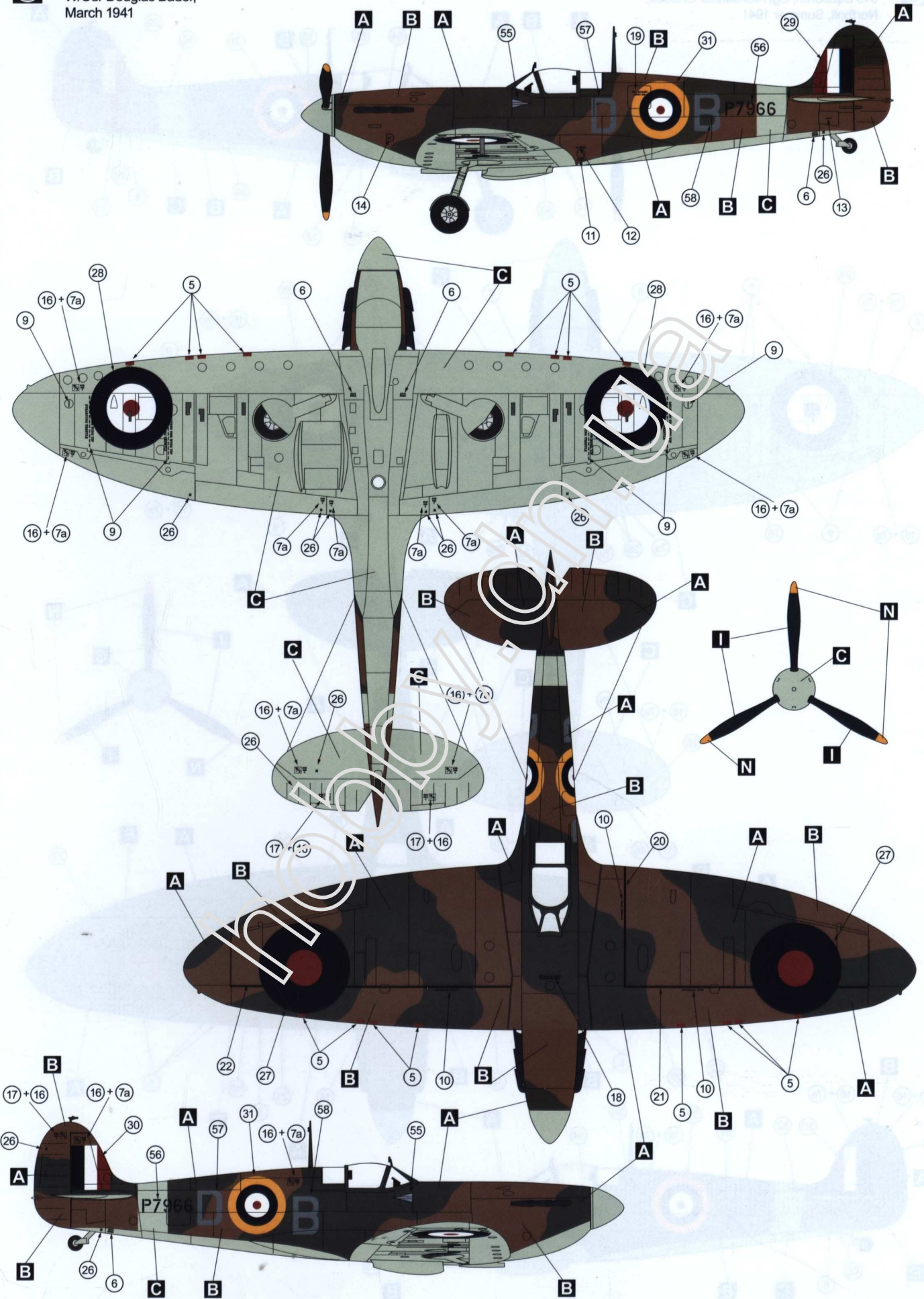

4

Spitfire IIA PK-K P7855, "Kryisia",
315 Squadron, Sgt Aleksander Chudek,
Northolt, Summer 1941

