



ЗИЛ-131 КШМ

Советский армейский автомобиль

Наиболее распространенным полноприводным грузовым автомобилем Советской Армии периода 70-х – 80-х годов был ЗИЛ-131. Его серийное производство началось в 1967 г. Автомобиль отличался высокой надежностью и проходимостью по бездорожью. Базовая модель предназначалась, в первую очередь, для перевозки личного состава или груза до 5 т.

Автомобиль поставлялся в страны-участницы Варшавского Договора, а также во многие страны Азии и Африки.

Всего с 1967 по 1990 г. было произведено почти 1000000 машин. С 1986г. производилась улучшенная модель ЗИЛ-131Н, затем производство было перенесено на Уральский автомобильный завод.

На базе шасси ЗИЛ-131 строились многочисленные модификации как для армии, так и для народного хозяйства СССР. Одной из них была командно-штабная машина (КШМ).

Тактико-технические характеристики автомобиля ЗИЛ-131 КШМ

Снаряженная масса, кг	7400
Длина с лебедкой, мм	7425
Ширина, мм	2500
Высота, мм.....	3255
База, мм.....	3350+1250
Колея передняя и задняя, мм	1820
Двигатель	ЗИЛ-131, 8-цил., 6,0 л, 150 л.с.
Максимальная скорость, км/ч	90
Запас хода по шоссе, км	850

ВНИМАНИЕ!

Перед сборкой внимательно прочитайте руководство по монтажу. Каждая деталь пронумерована. Соблюдать последовательность монтажа. Необходимые рабочие инструменты: нож и напильник для зачистки деталей; резиновая лента, клейкая лента и зажимы для сушки белья для прижатия склеиваемых деталей. Детали из пластика очистить в растворе мягкого моющего средства и высушить на воздухе для того, чтобы краска и переводные картинки лучше прилипали. Перед приклеиванием проверить, подходят ли детали; клей наносить экономно. Хром и краску удалить с поверхностей склеивания. Небольшие детали покрасить перед тем, как они будут удалены из рамок. Краску необходимо хорошо просушить, только после этого продолжать сборку. Каждую соответствующую переводную картинку отдельно вырезать и примерно на 20 секунд окунуть в теплую воду. На обозначенном месте картинку отделить от бумаги и прижать промокательной бумагой.

ИСПОЛЬЗУЕМЫЕ КРАСКИ / USED COLORS:

	Model Master		
A	1712	Хаки, полуматовый	Field Green
B	1597	Черный, полуматовый	Semigloss Black
C	1749	Черный, матовый	Flat Black
D	1781	Алюминий	Aluminum
E	1785	Ржавчина	Rust
F	1790	Серебристый	Chrome Silver

ZiL-131 KShM

Soviet Army Vehicle

ZiL-131 was the main all-road Soviet Army truck of 70's – 80's. It's serial production was launched in 1967. This truck featured high reliability and all-road abilities.

The basic model was used mainly as personnel transport or 5-t cargo truck.

Those trucks were supplied to Warsaw Pact countries and also to many countries of Asia and Africa.

There had been produced about 1000000 trucks since 1967 till 1990 in ZiL plant. Improved model ZiL-131N was being produced since 1986 and later production moved to Ural Automotive Plant.

There were many ZiL-131 modifications for Soviet Army and civilian use. One of them was the Command Vehicle (KShM).

Tactical and Technical Specifications of ZiL-131 KShM

Curb weight, kg	7400
Length with winch, mm	7425
Width, mm	2500
Height, mm	3255
Wheel base, mm	3350+1250
Track front & rear, mm.....	1820
Engine.....	ZiL-131, 8 cyl., 6,0 l, 150 hp
Max. Speed, km/h.....	90
Range, km	850

CAUTION!

Read the instructions thoroughly prior to assembly. Each component is numbered. Adhere to specified sequence of assembly. Tools required: knife and file for removal of components from frame; rubber bond, adhesive tape and clothes pegs for clamping components together after applying adhesive. Clean plastic components in a mild detergent solution and allow to air-dry so that paint and transfers adhere better. Prior to applying adhesive, check to see whether the components fit together; apply adhesive sparingly. Remove chrome and paint from the contact surfaces. Paint small components before removing them from the frame. Allow paint to dry well, and only then continue to assemble. Cut out each transfer individually and immerse in warm water for approx. 20 seconds. Slide transfer off paper and into designated position, then press on with blotting paper.

	Model Master		
G	2724	Красный, глянцевый	Turn Signal Red
H	2723	Янтарный, глянцевый	Turn Signal Amber
J	1736	Кожа	Leather
K	1596	Белый, полуматовый	Semigloss White
L	1721	Серый, матовый	Medium Gray
M	1701	Коричневый, матовый	Military Brown

01 СТАДИЯ СБОРКИ
ASSEMBLY STEP

03 СБОРОЧНАЯ ЕДИНИЦА
ASSEMBLY UNIT

■ ПРИ СБОРКЕ НЕ ИСПОЛЬЗУЕТСЯ
PARTS NOT FOR USE

? ПРОИЗВОЛЬНЫЙ ВЫБОР
OPTIONAL

x2 СДЕЛАТЬ ДВЕ ДЕТАЛИ
MAKE 2 PCS

A ИСПОЛЬЗУЕМАЯ КРАСКА
USED COLOR

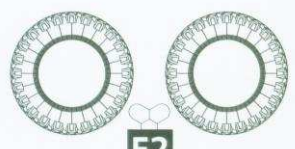
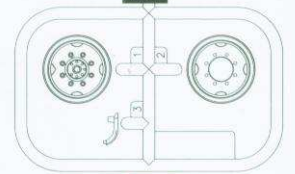
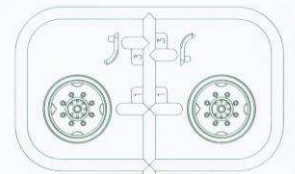
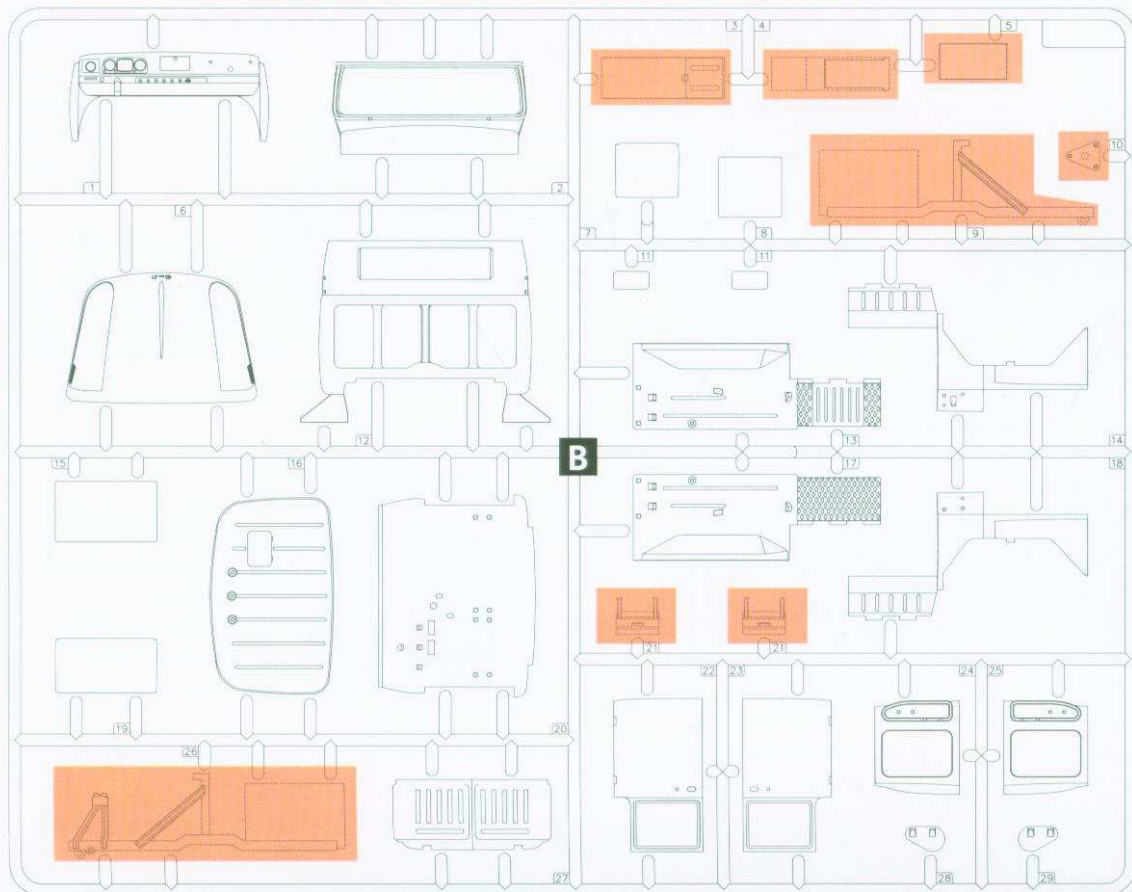
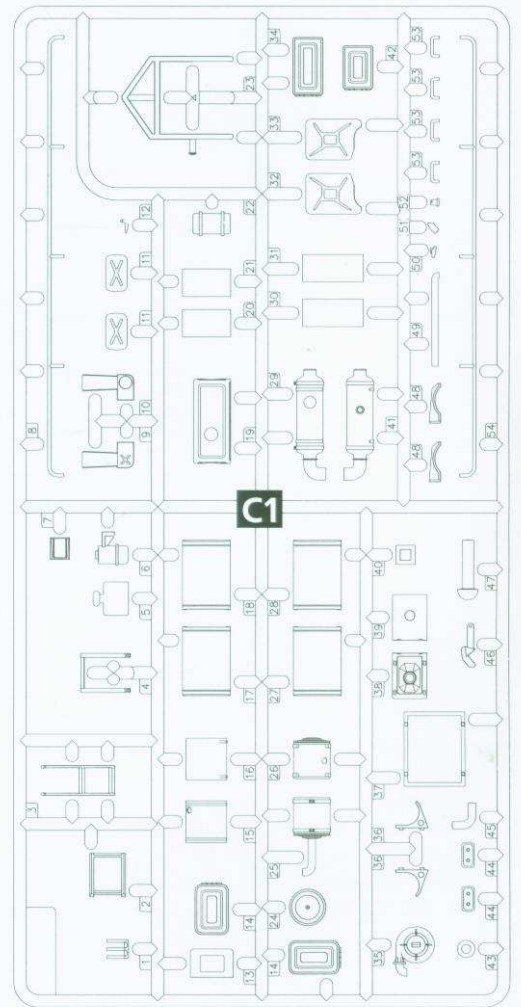
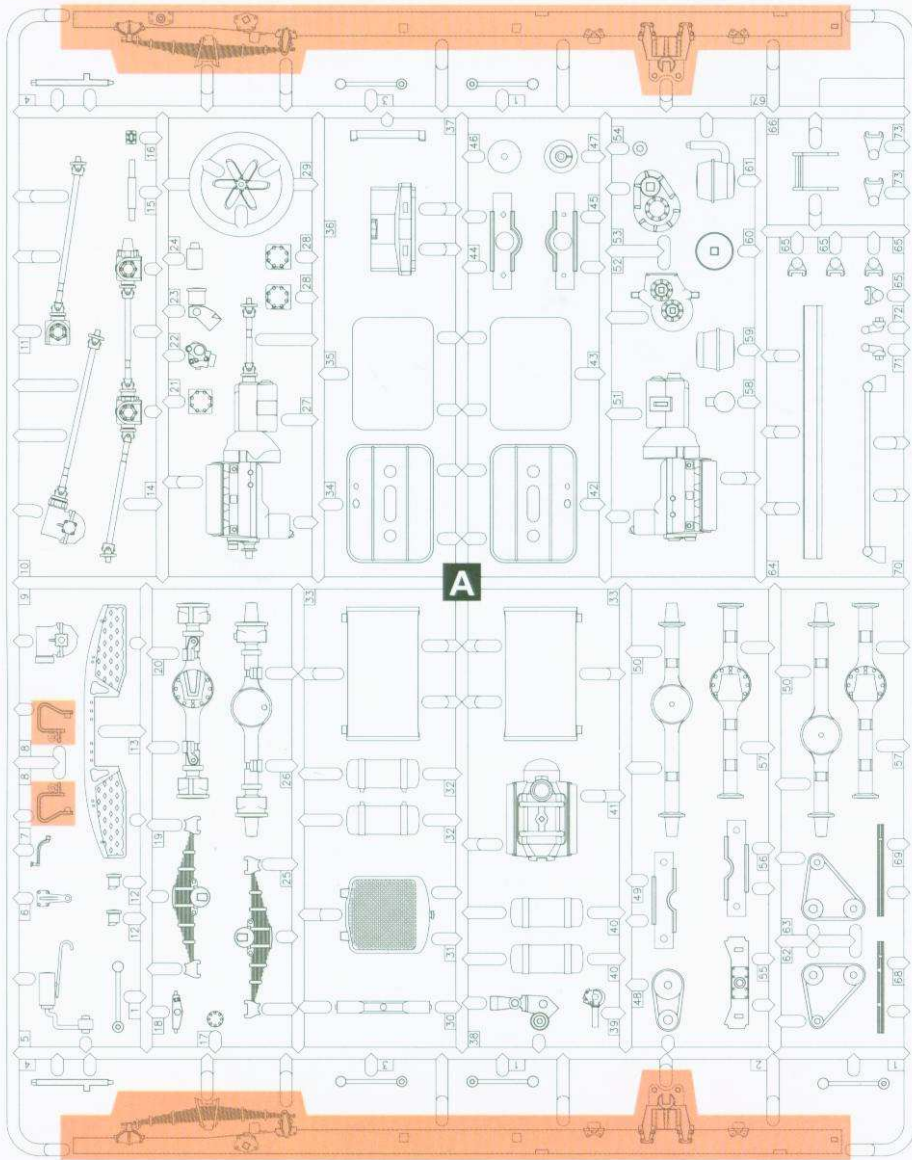

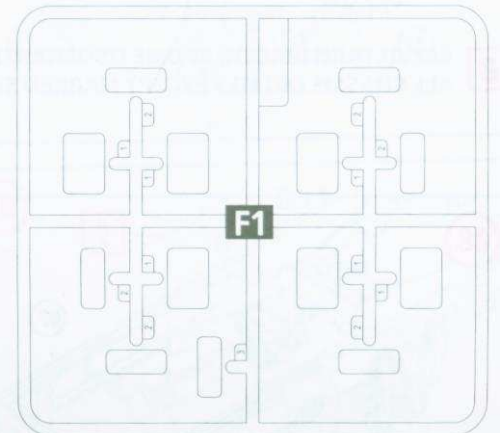
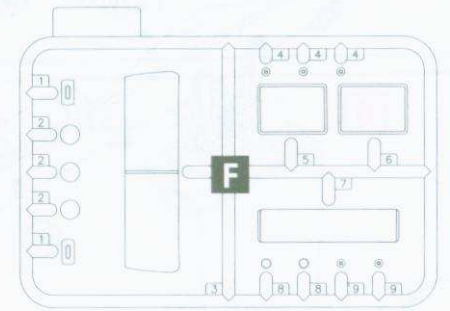
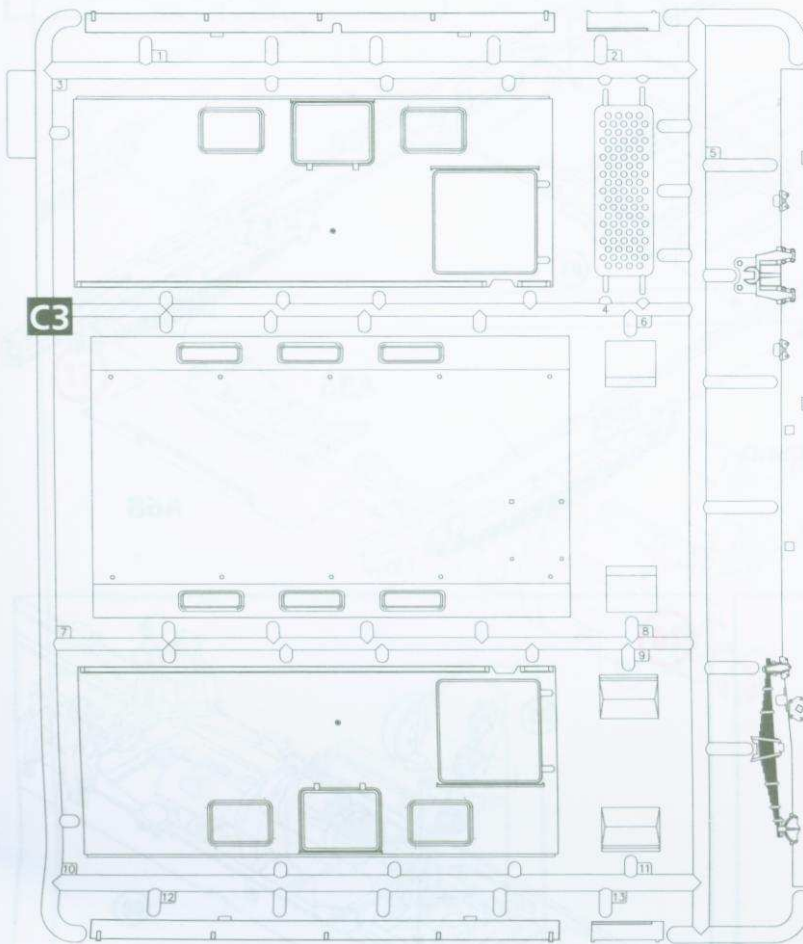
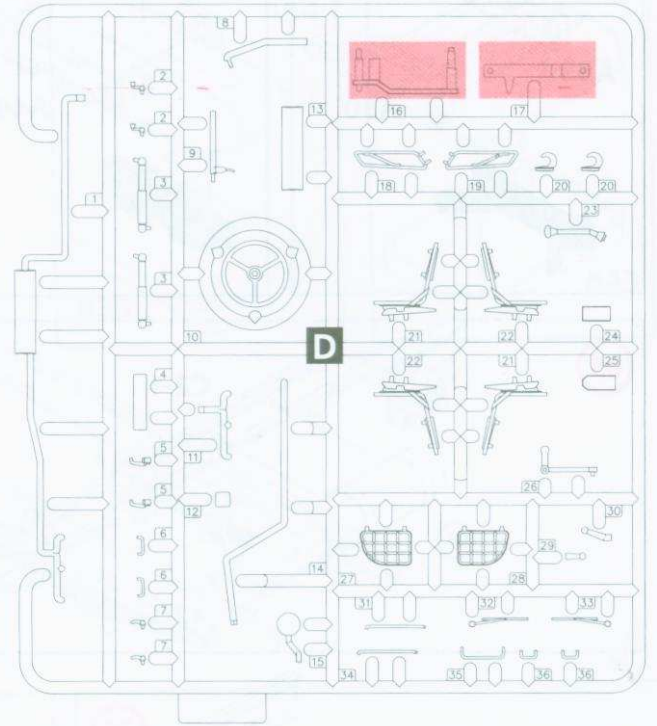
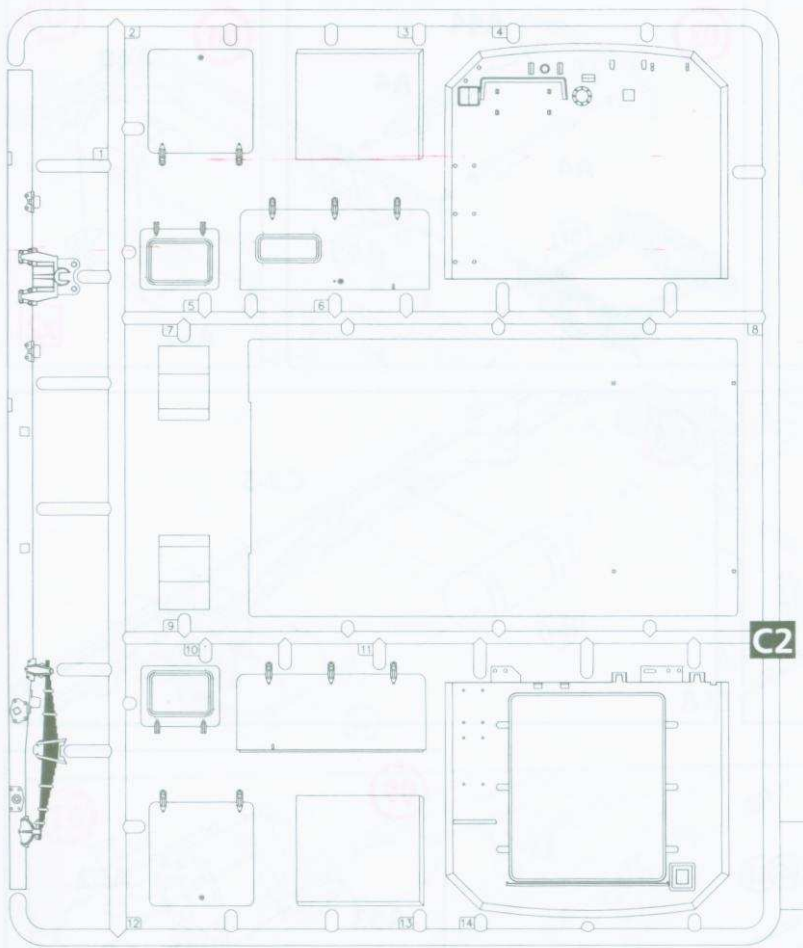

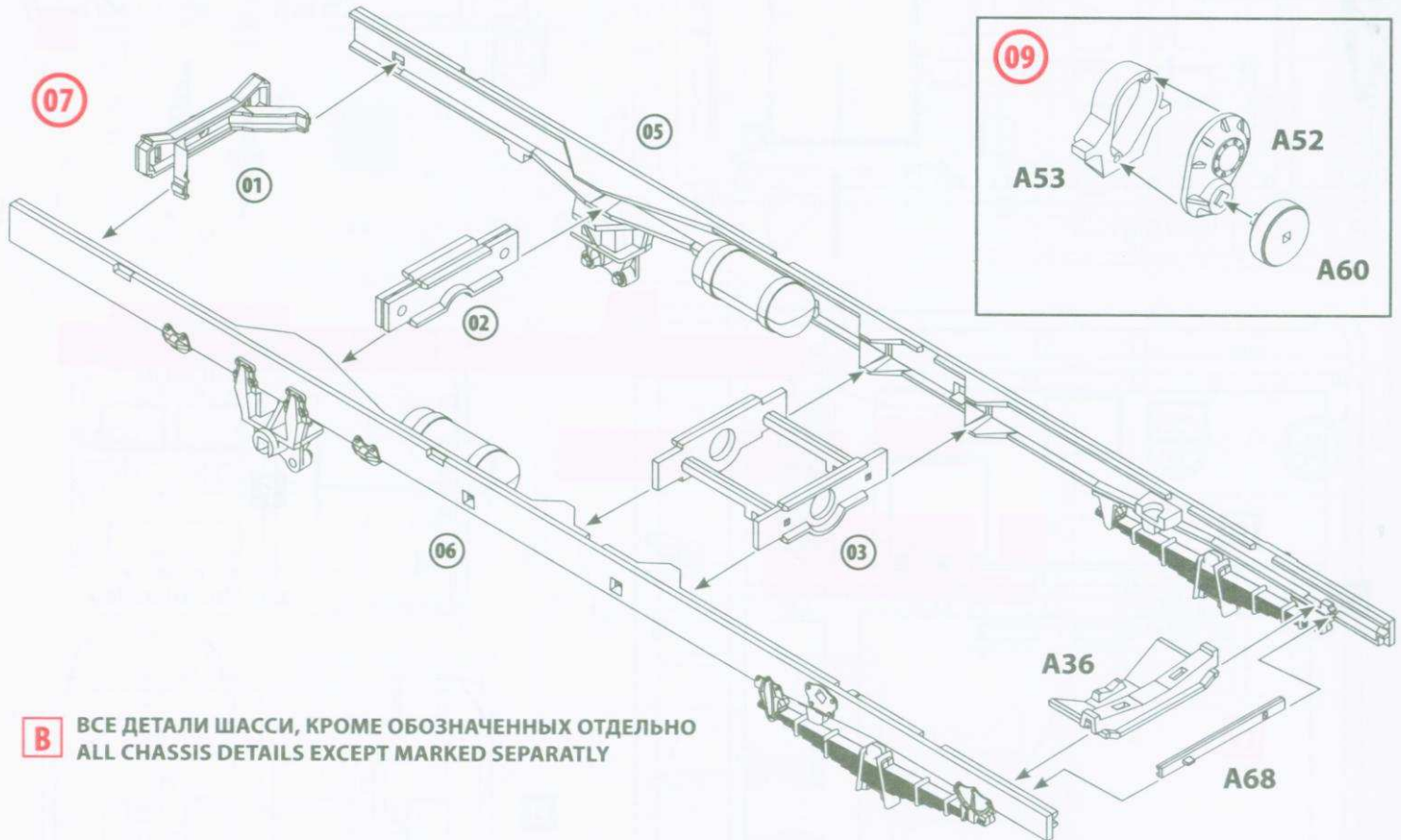
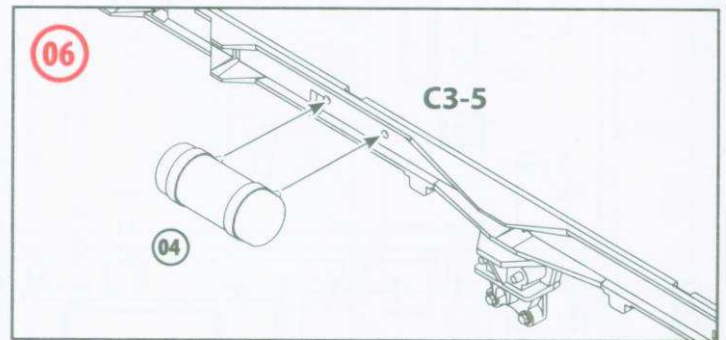
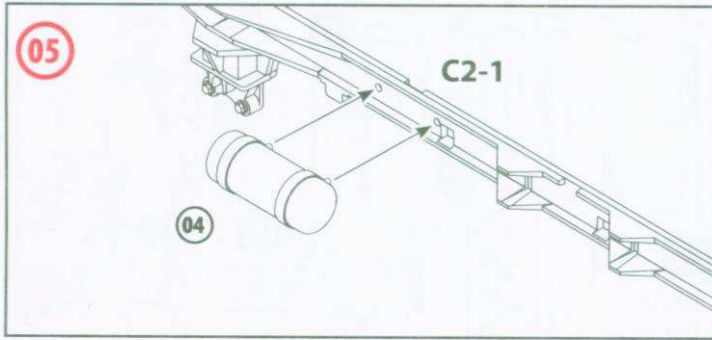
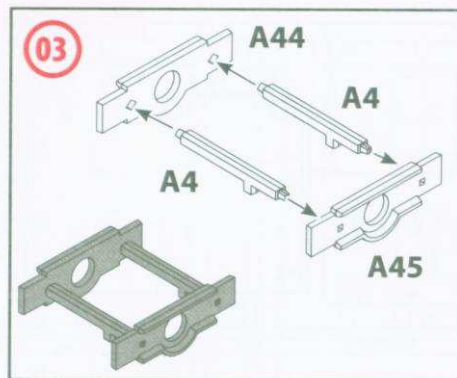
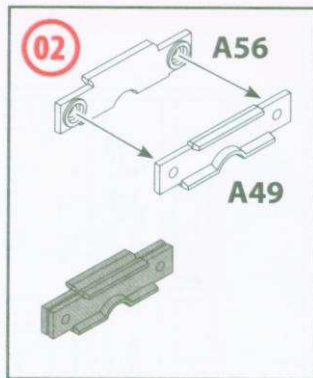
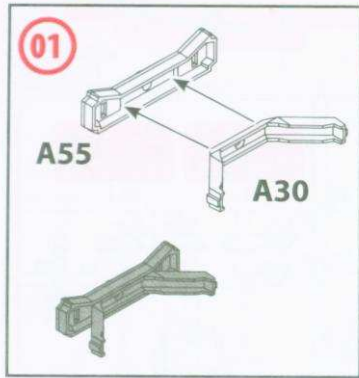

B ВСЕ ДЕТАЛИ ШАССИ, КРОМЕ ОБОЗНАЧЕННЫХ ОТДЕЛЬНО
 ALL CHASSIS DETAILS EXCEPT MARKED SEPARATLY

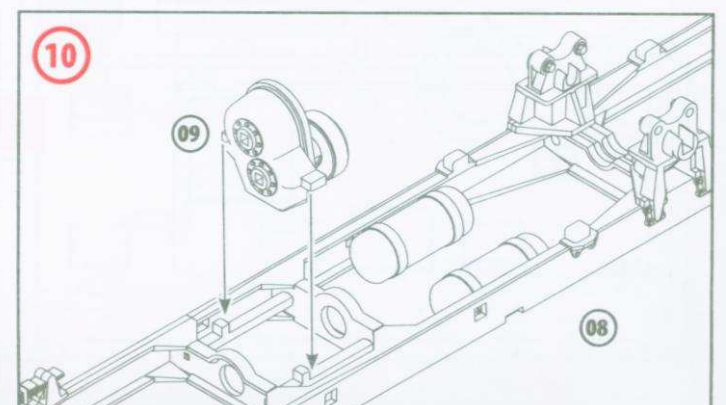
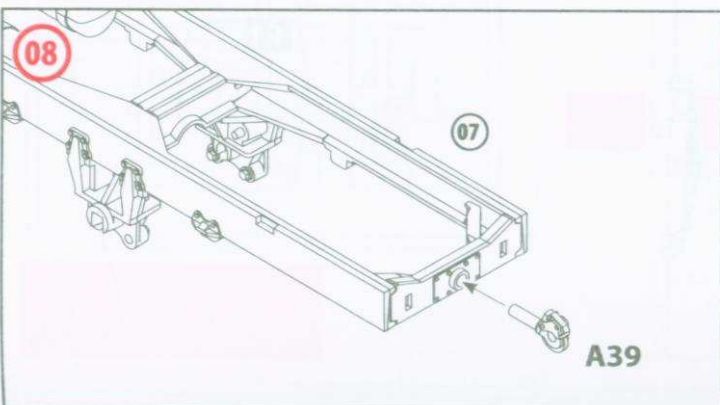

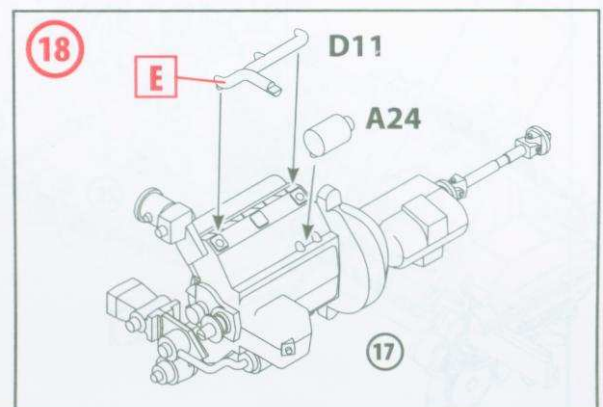
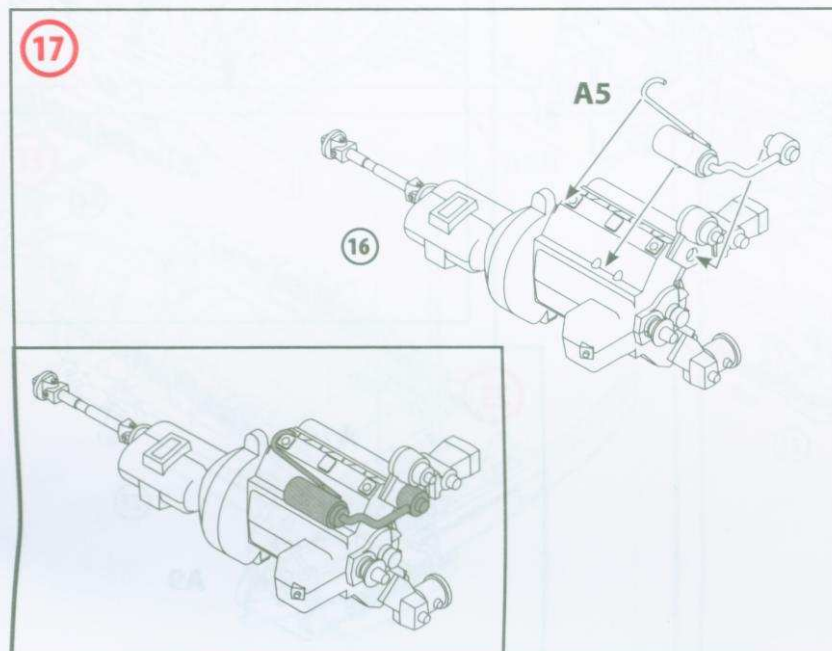
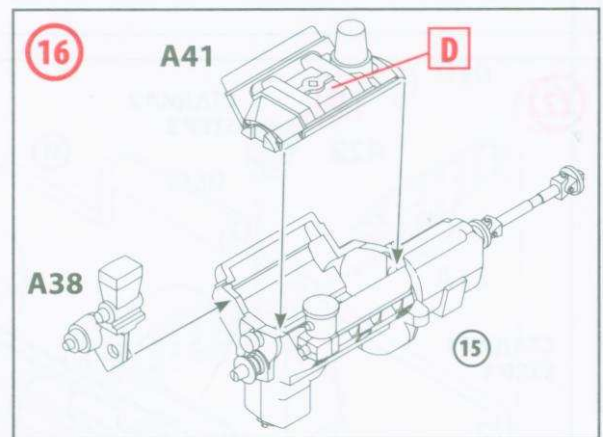
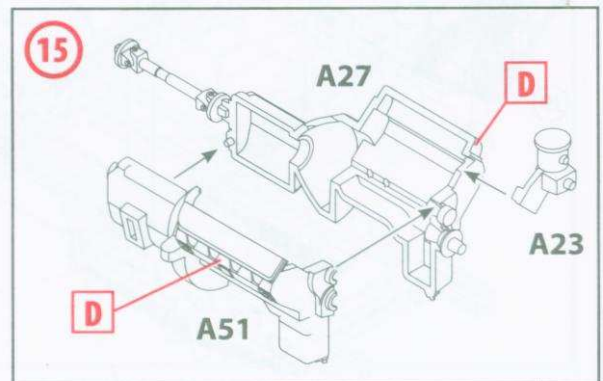
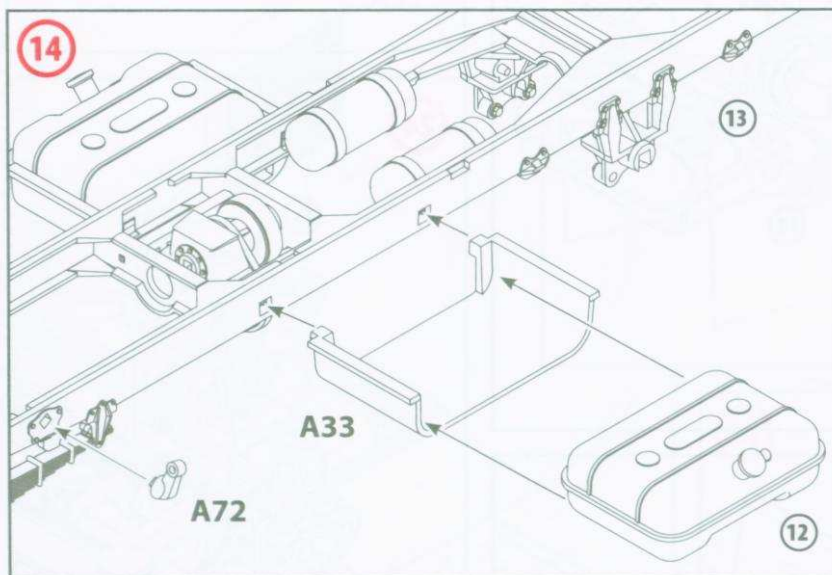
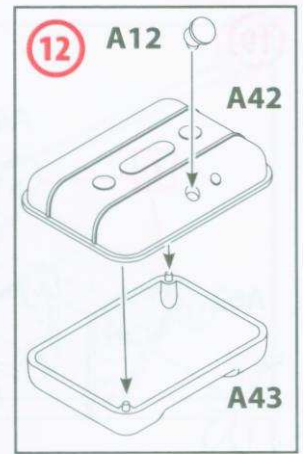
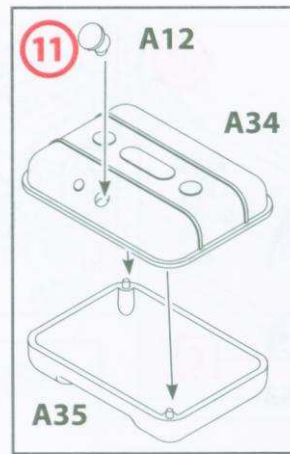
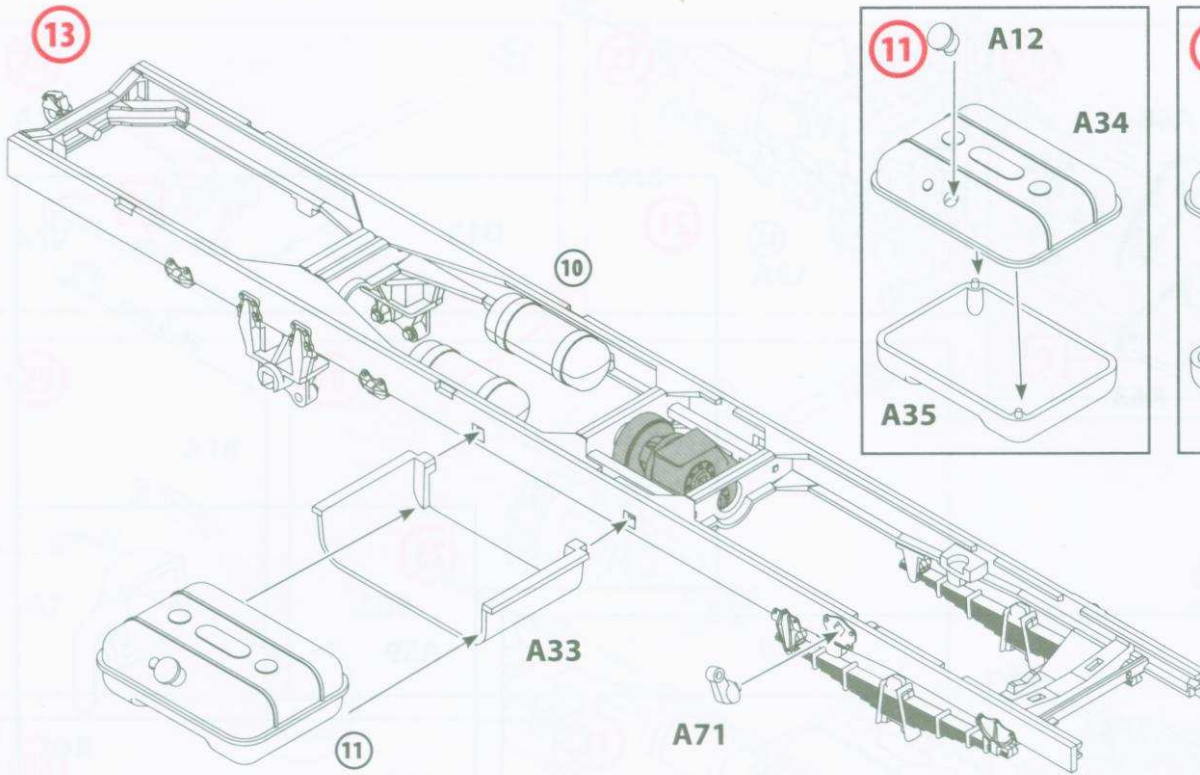

19

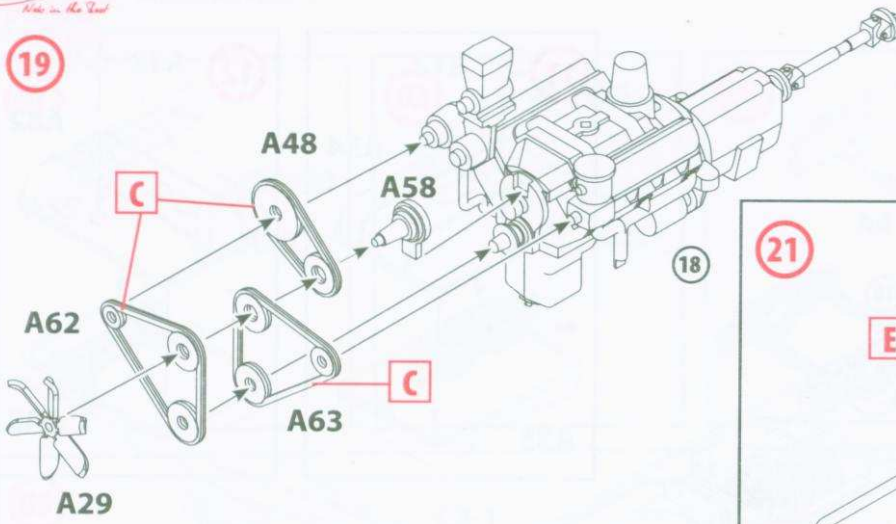

21

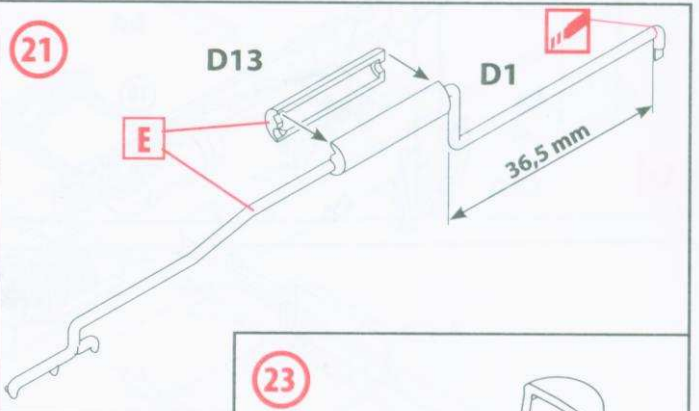

20

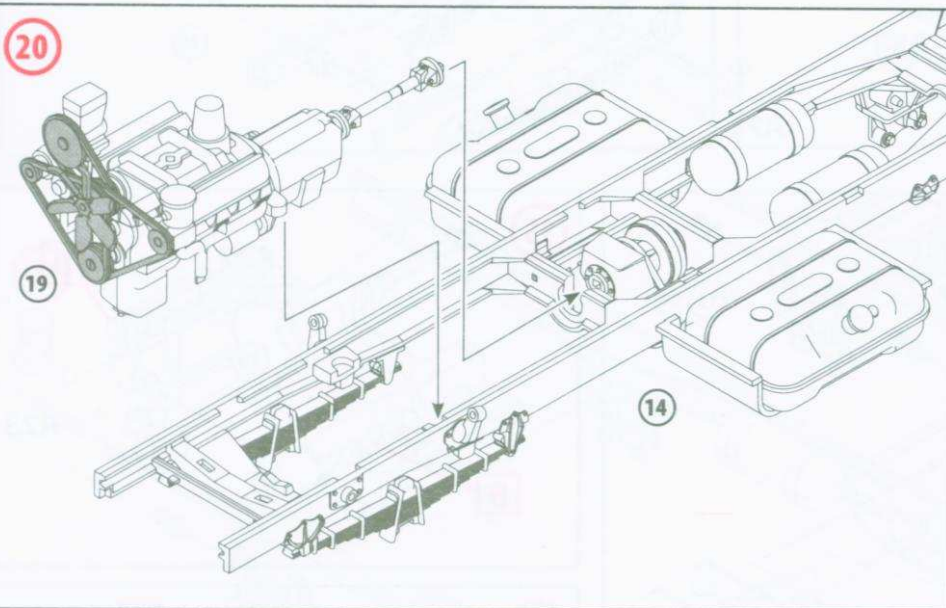

23

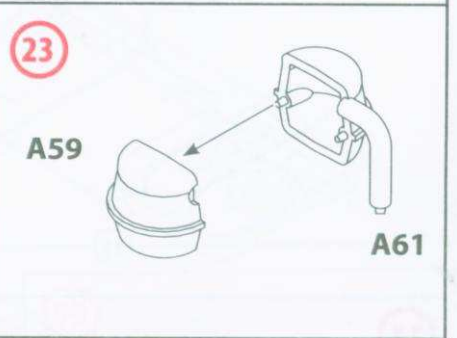

24

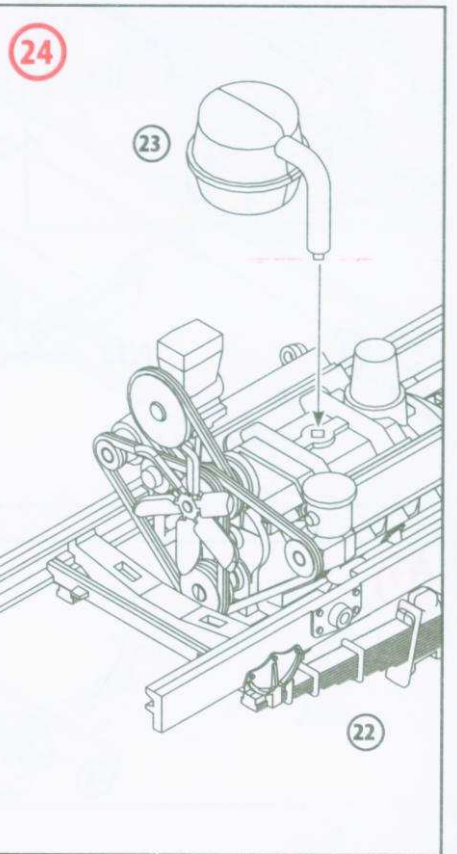

22

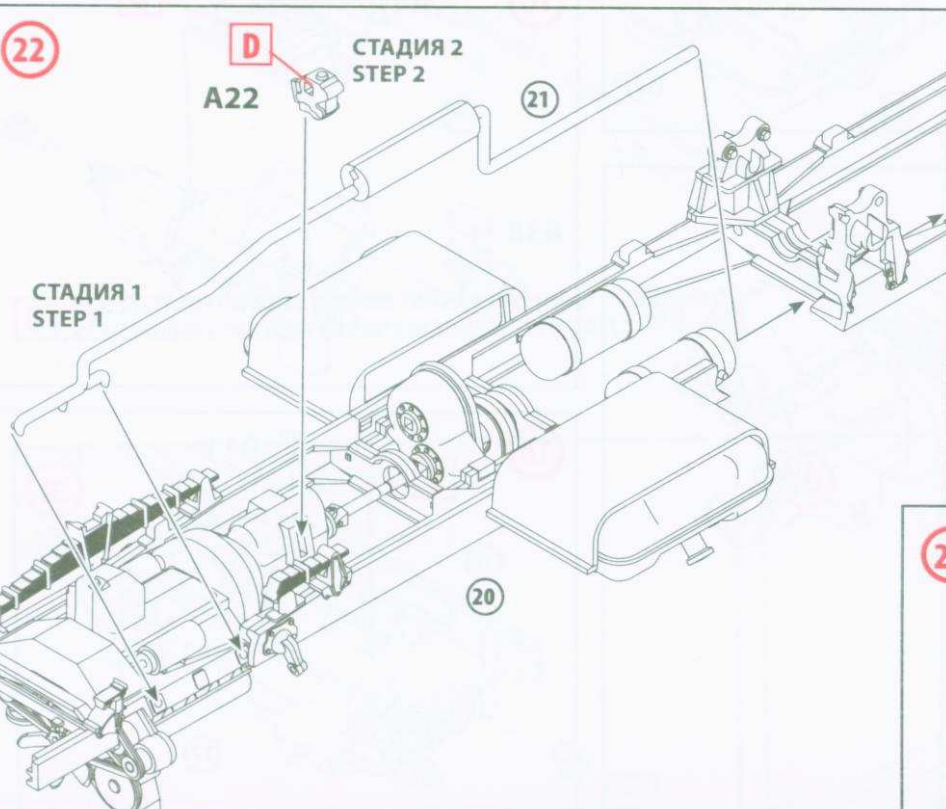

25

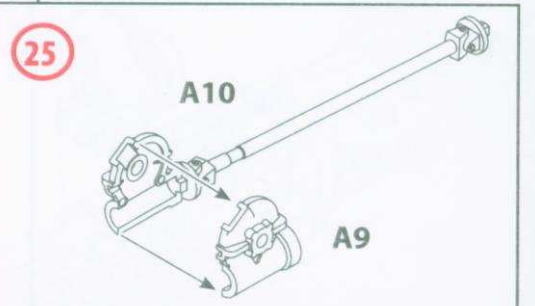

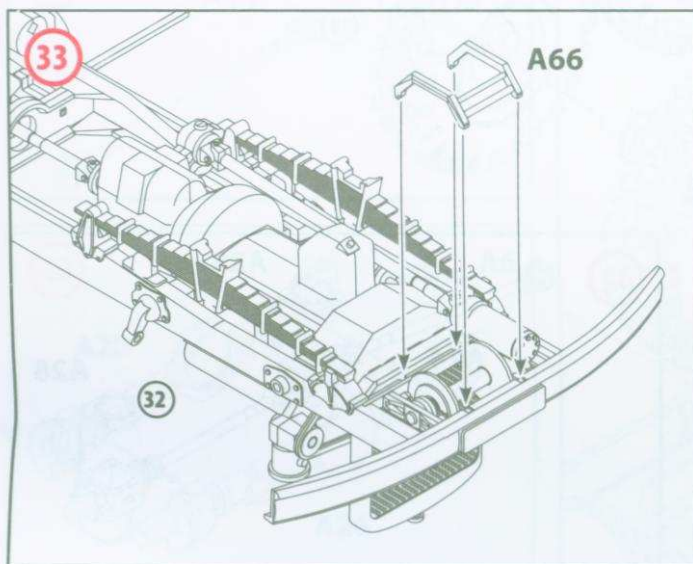
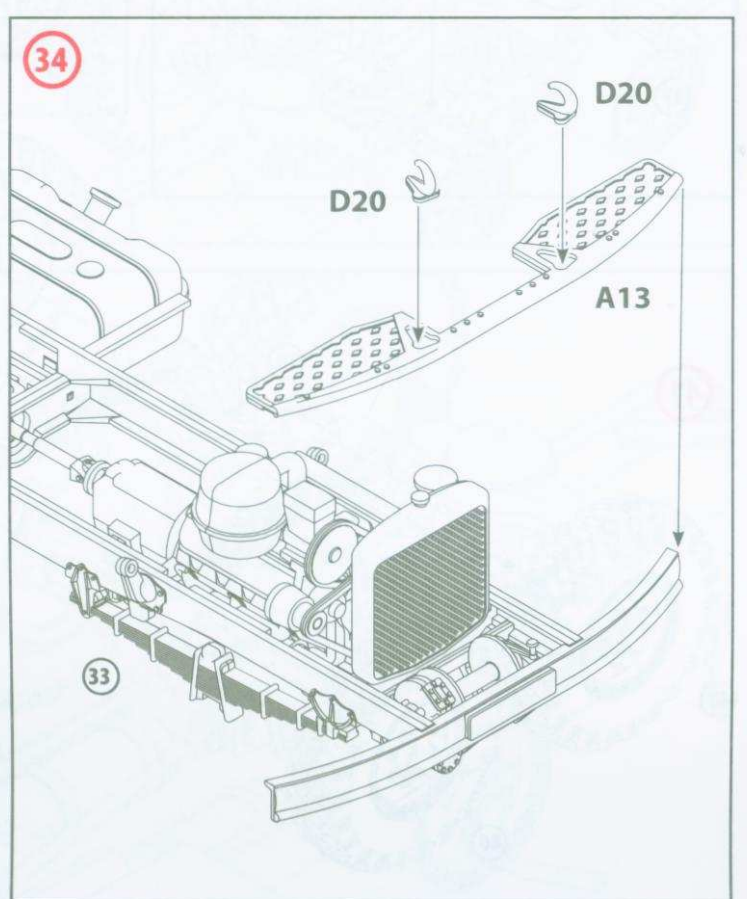
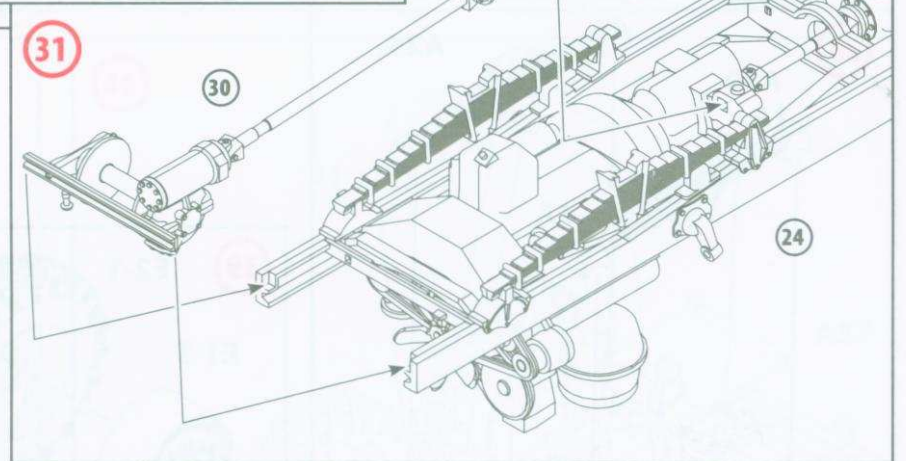
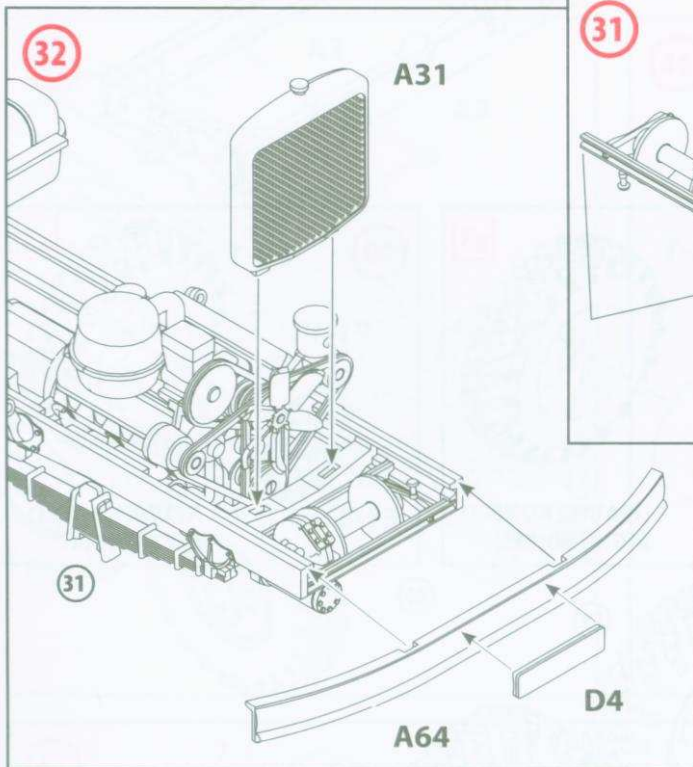
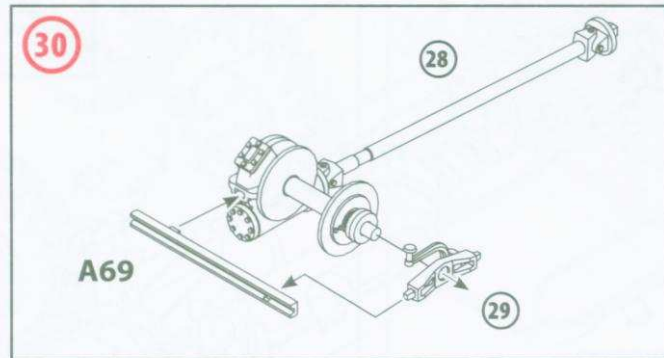
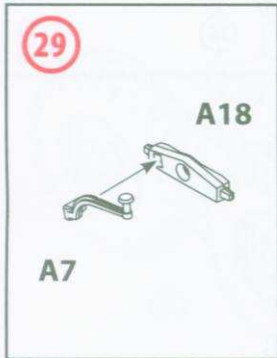
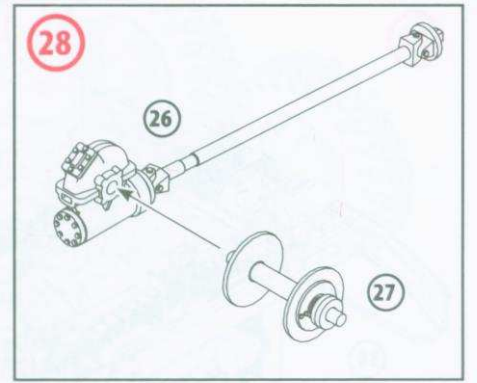
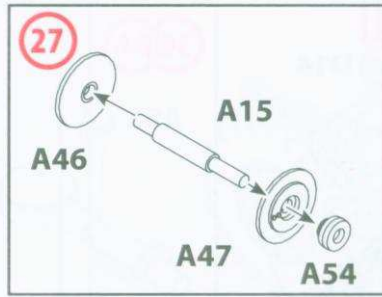
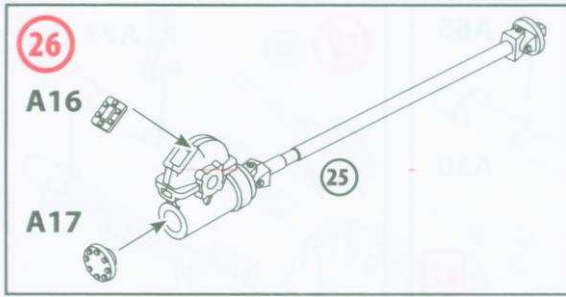

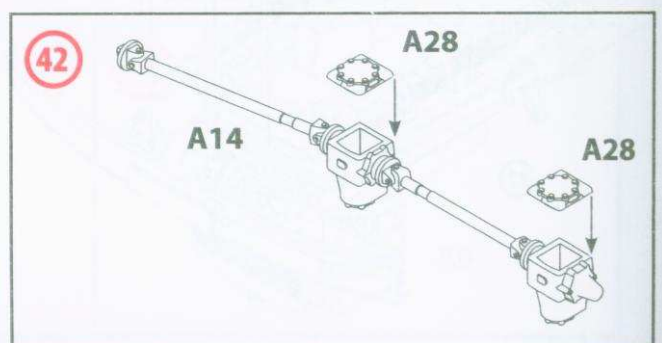
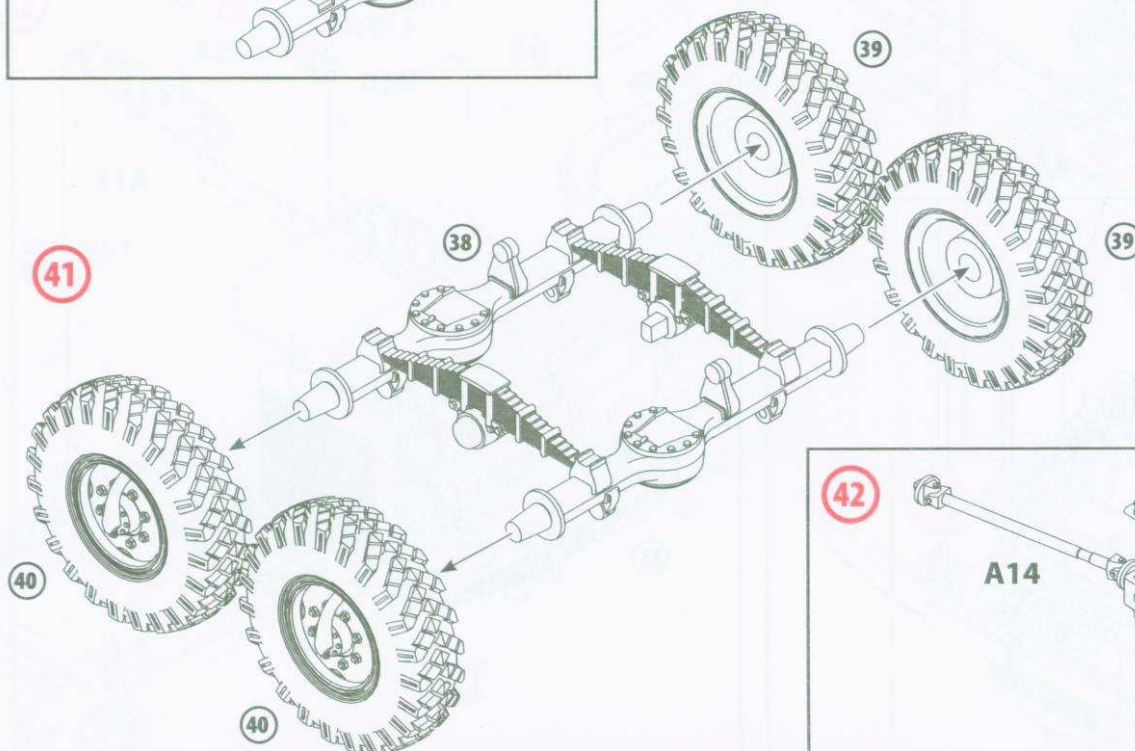
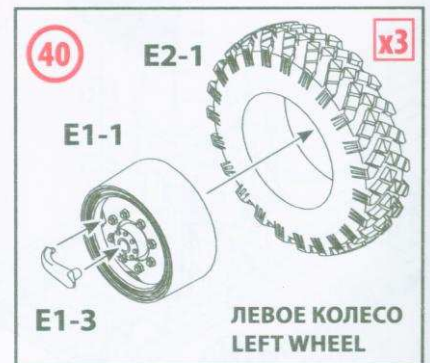
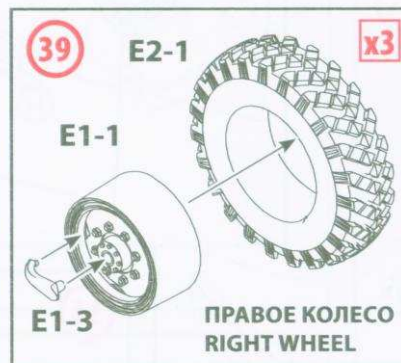
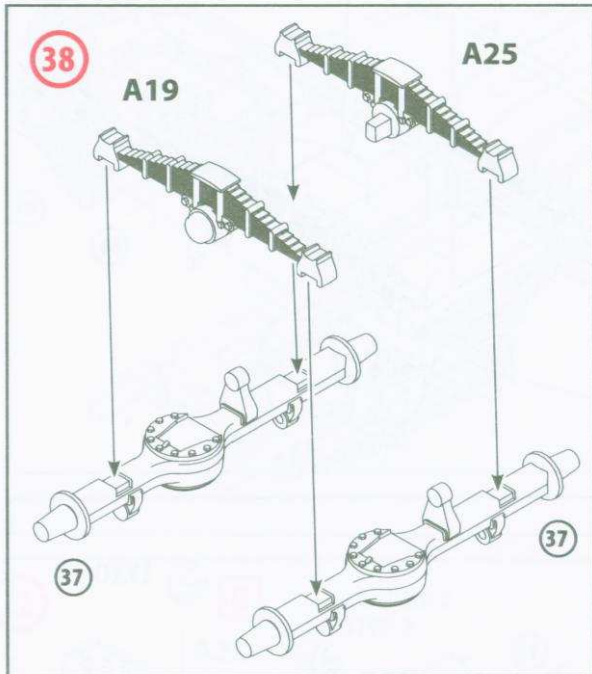
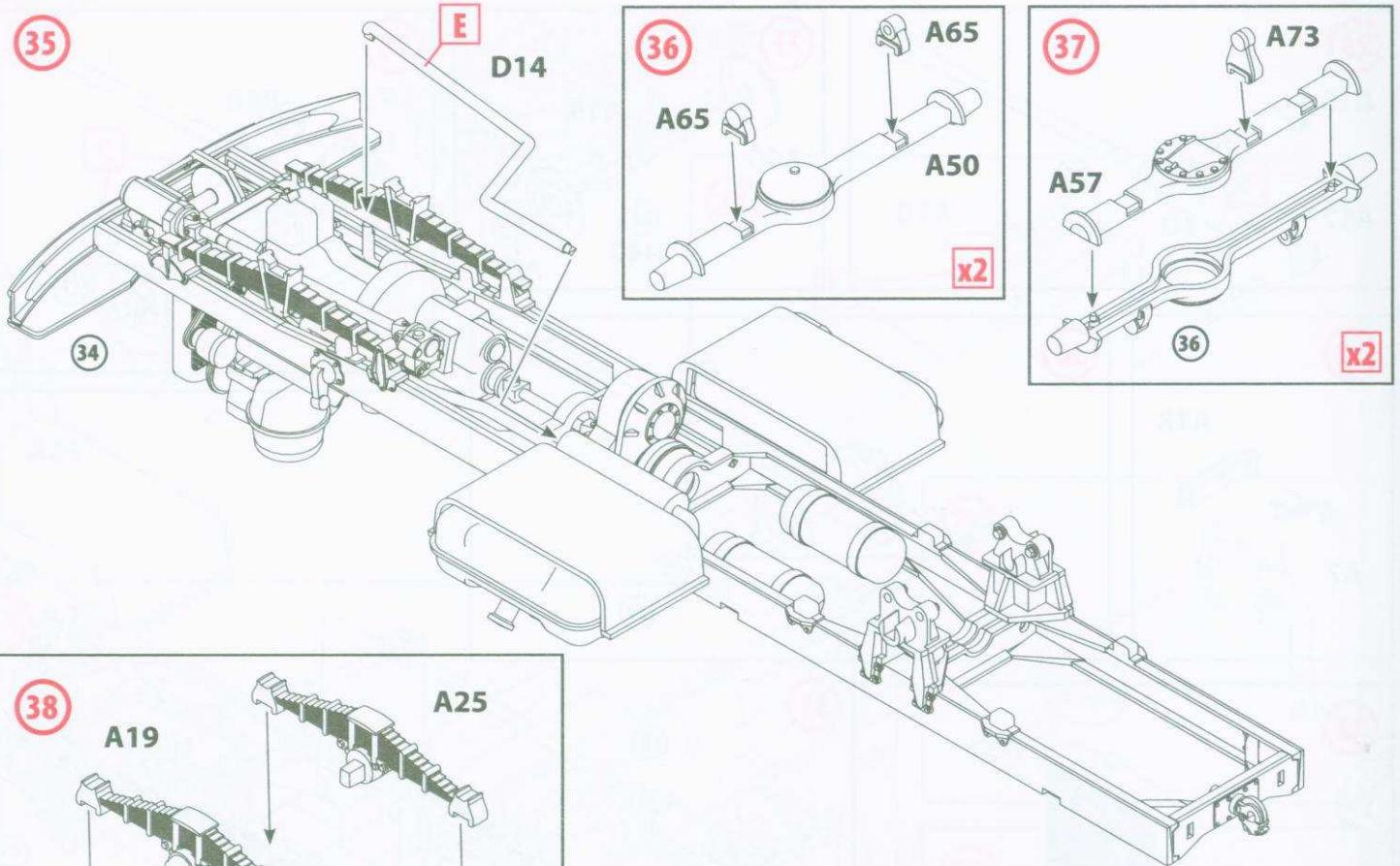

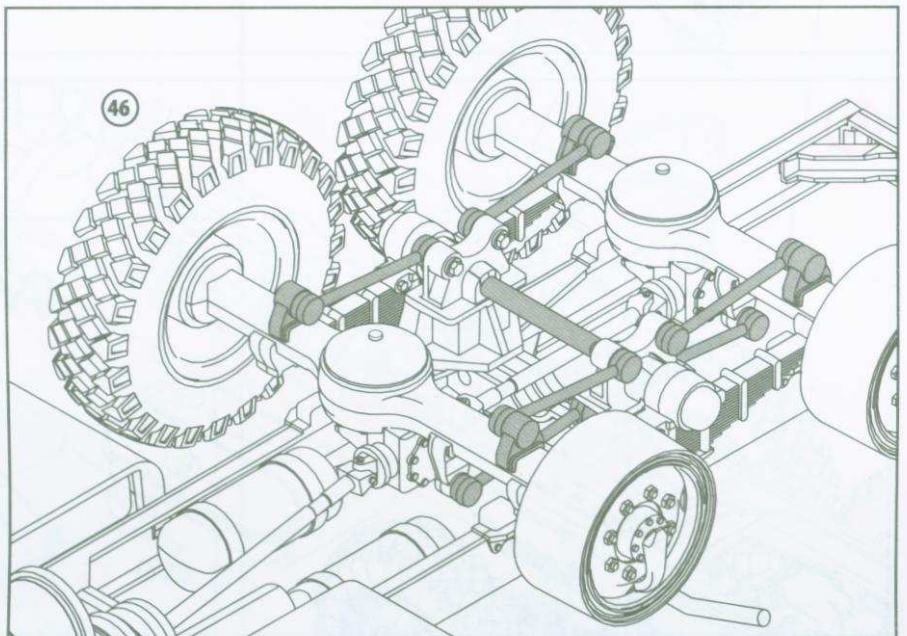
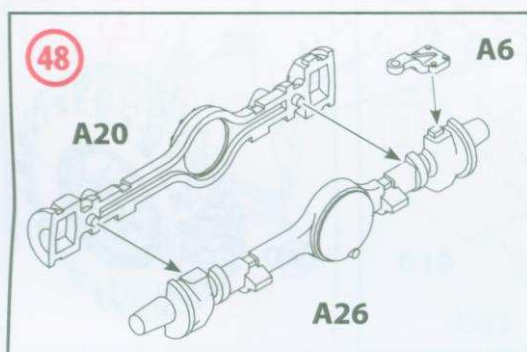
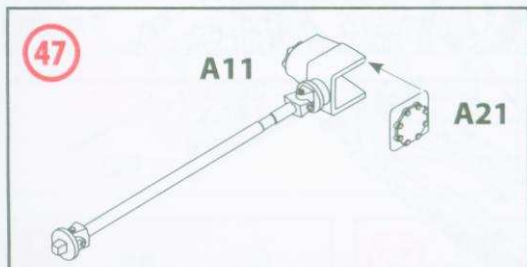
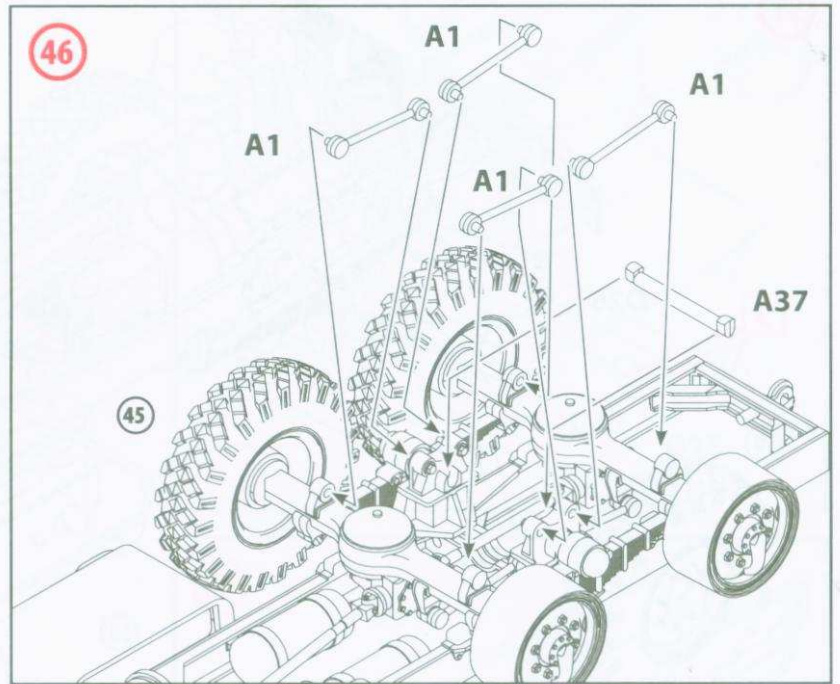
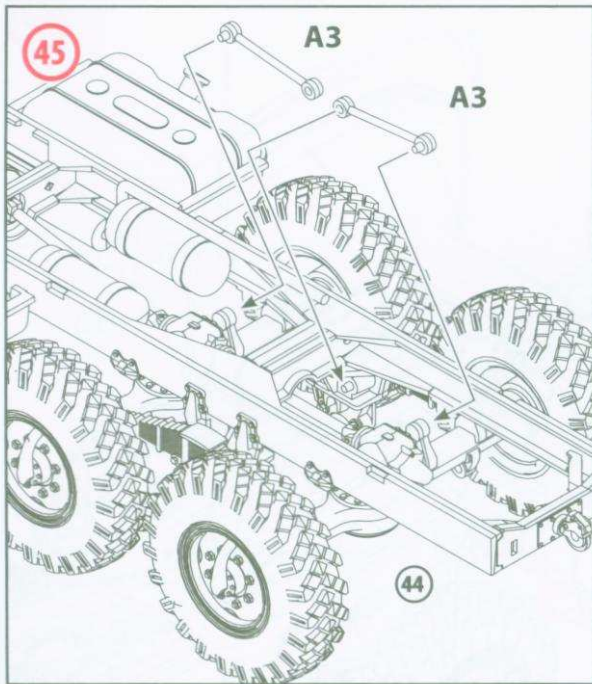
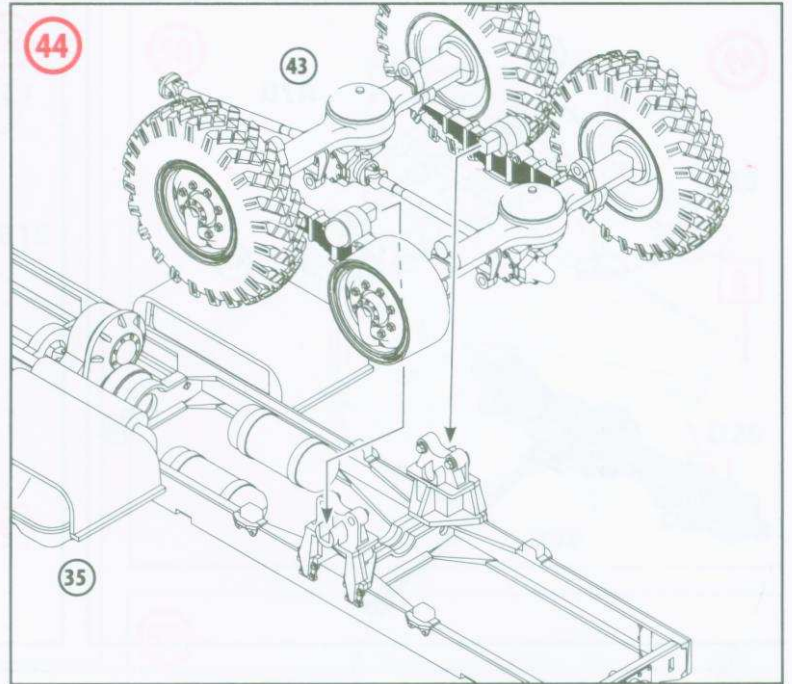
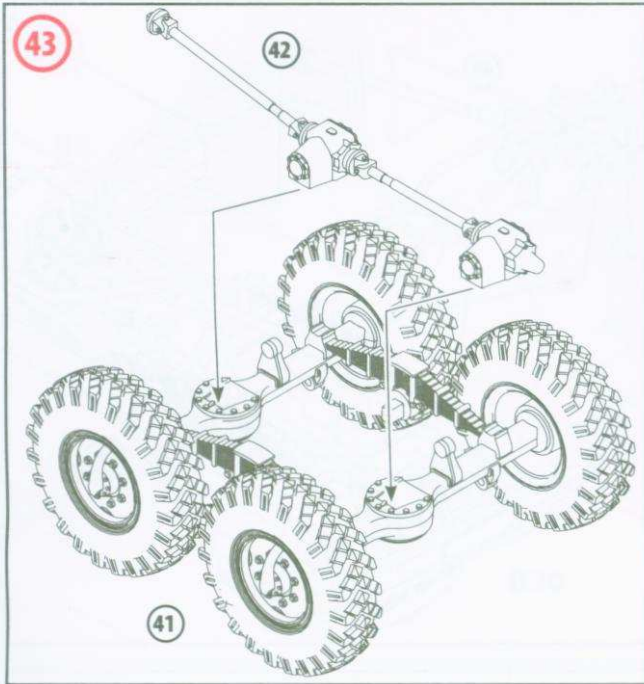

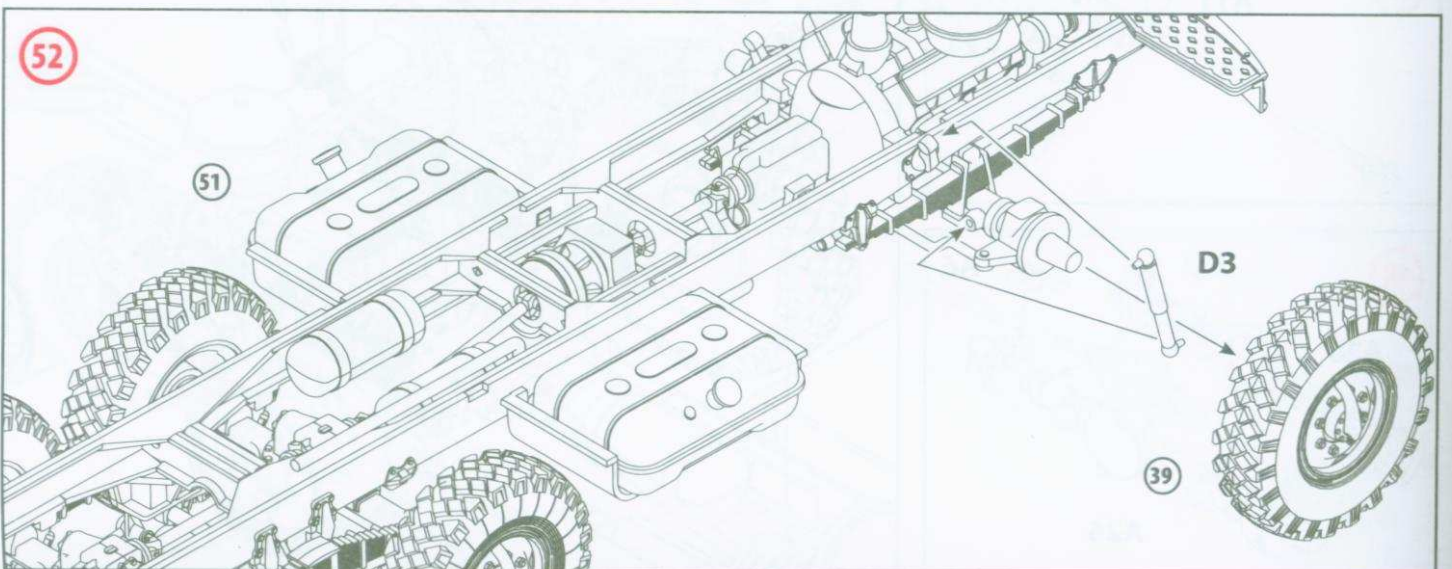
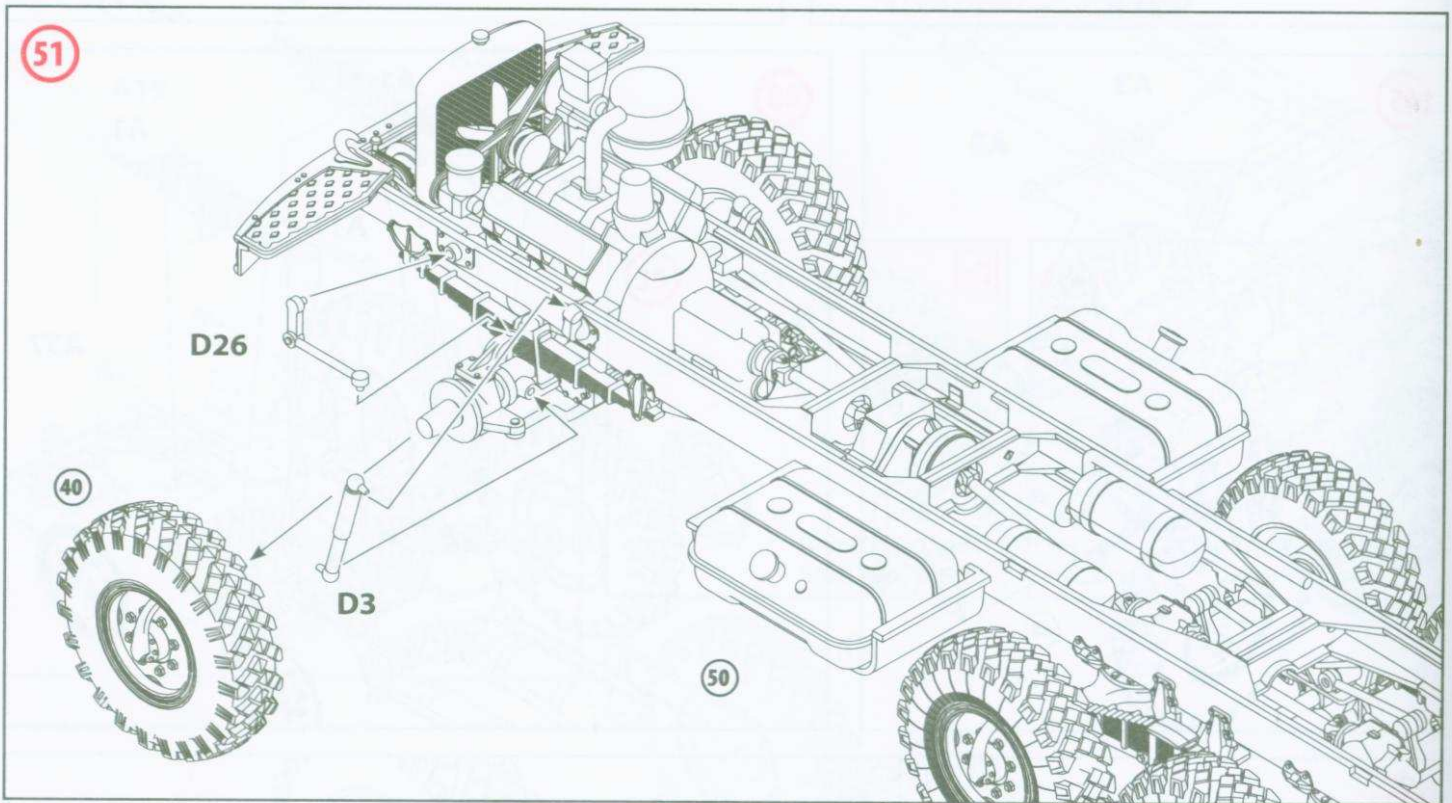
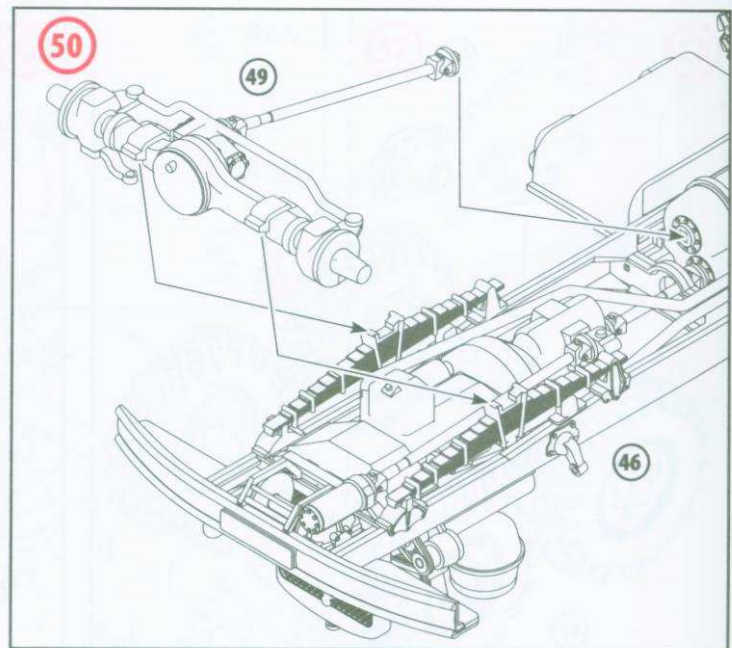
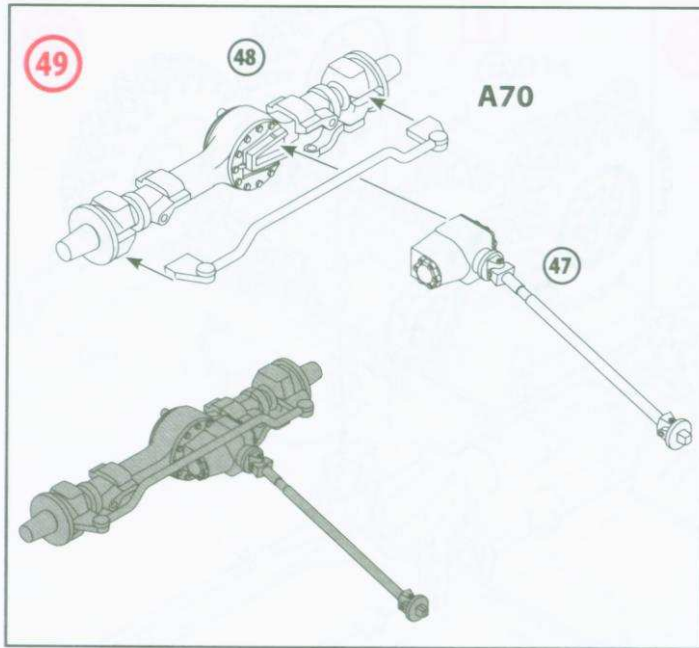

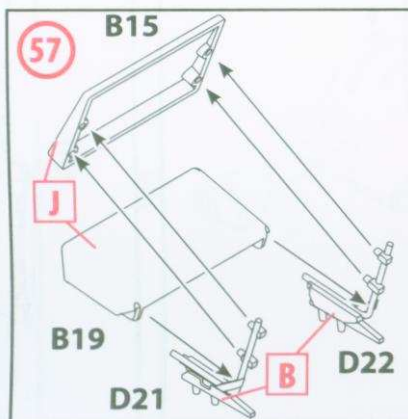
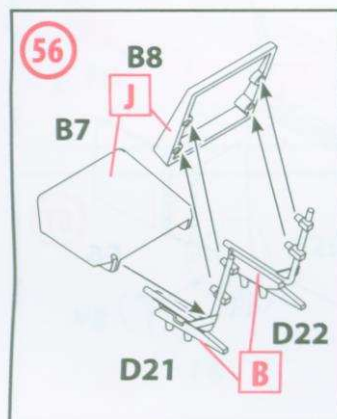
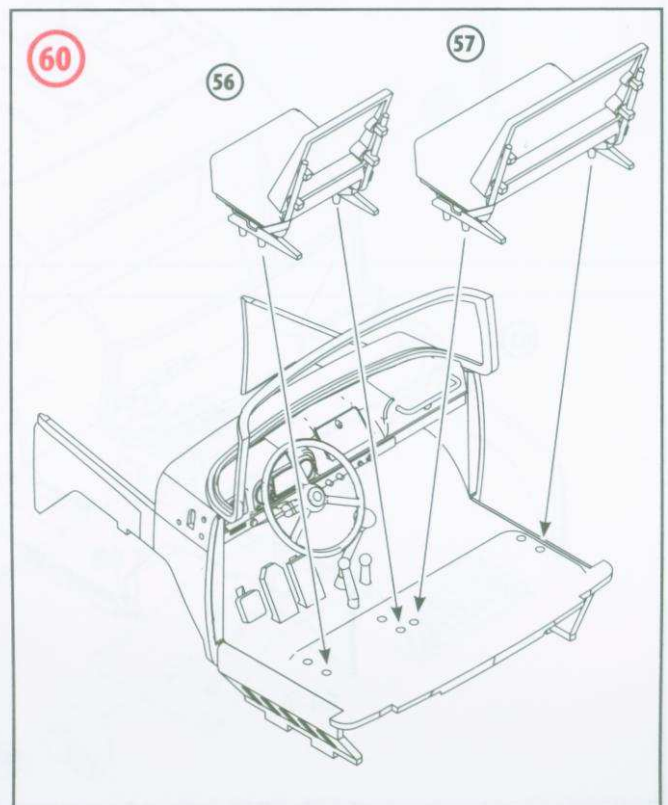
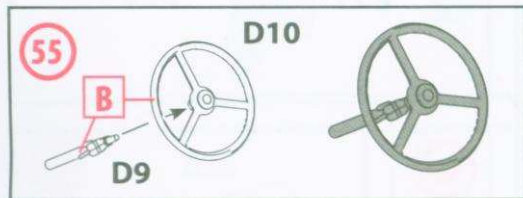
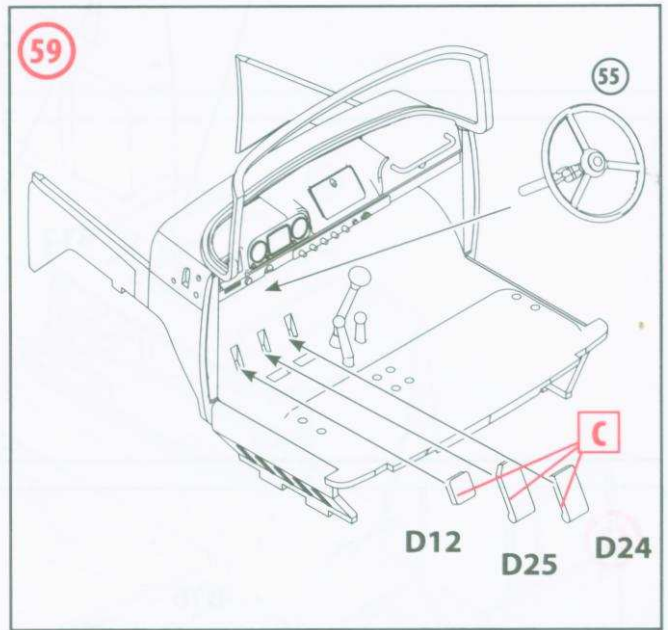
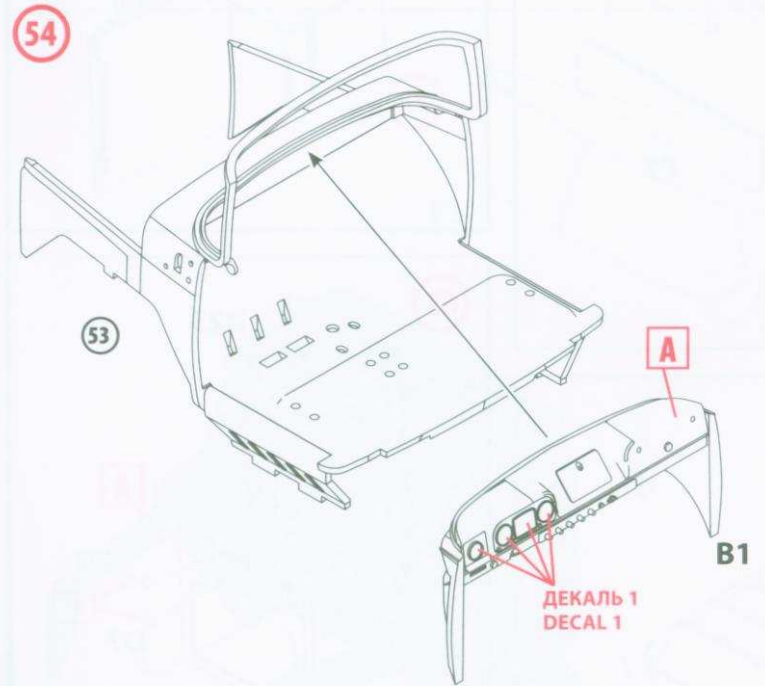
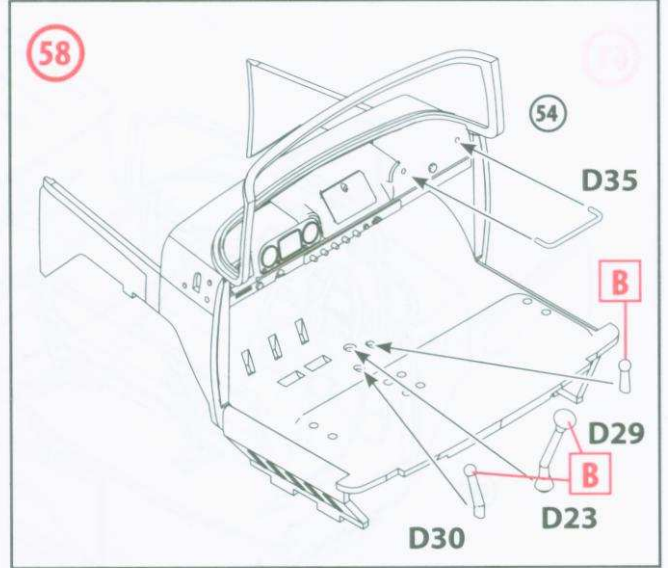
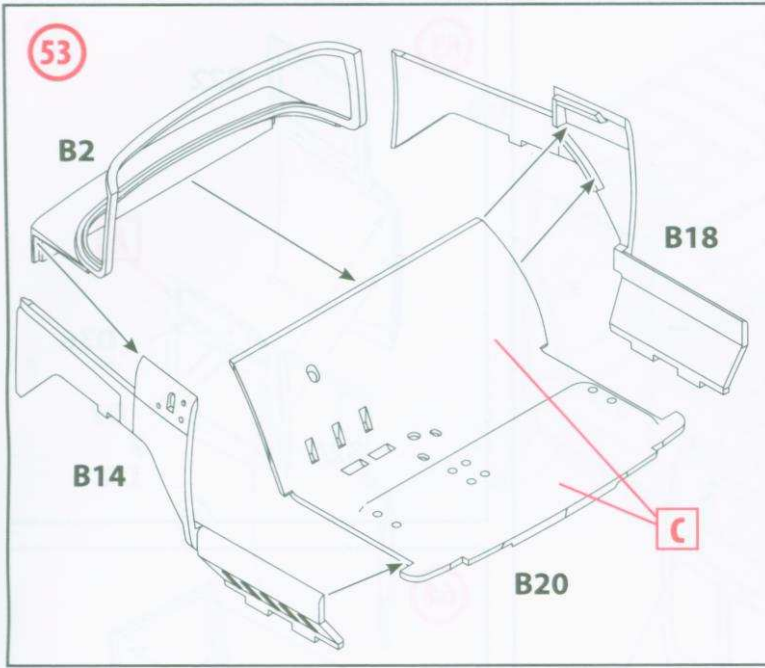

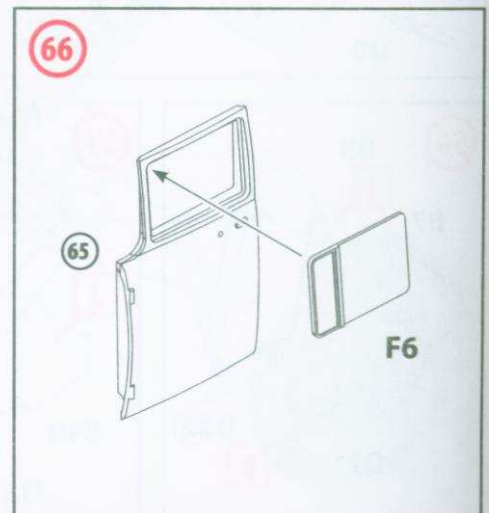
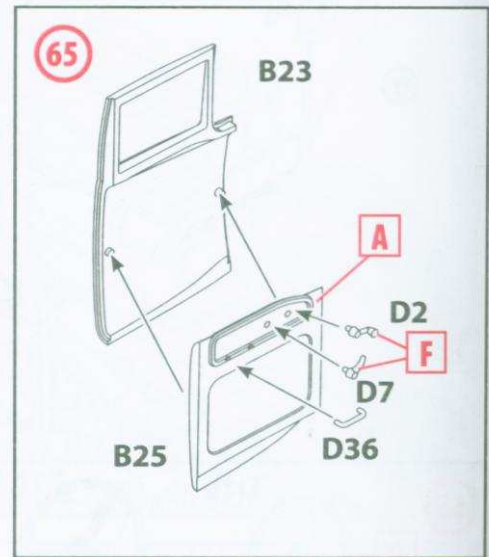
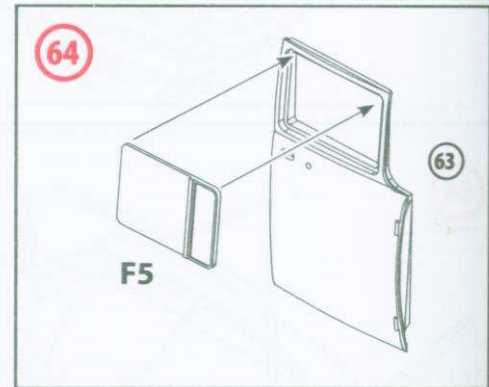
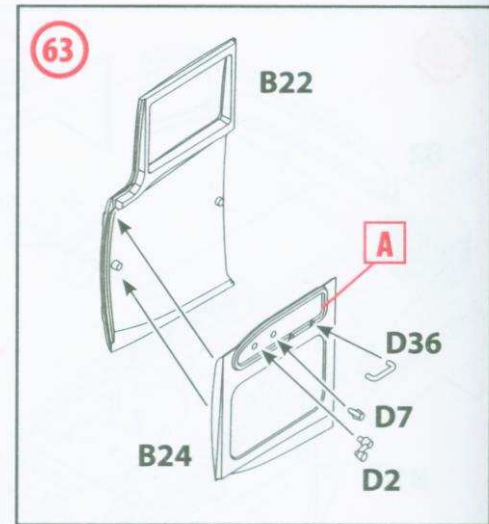
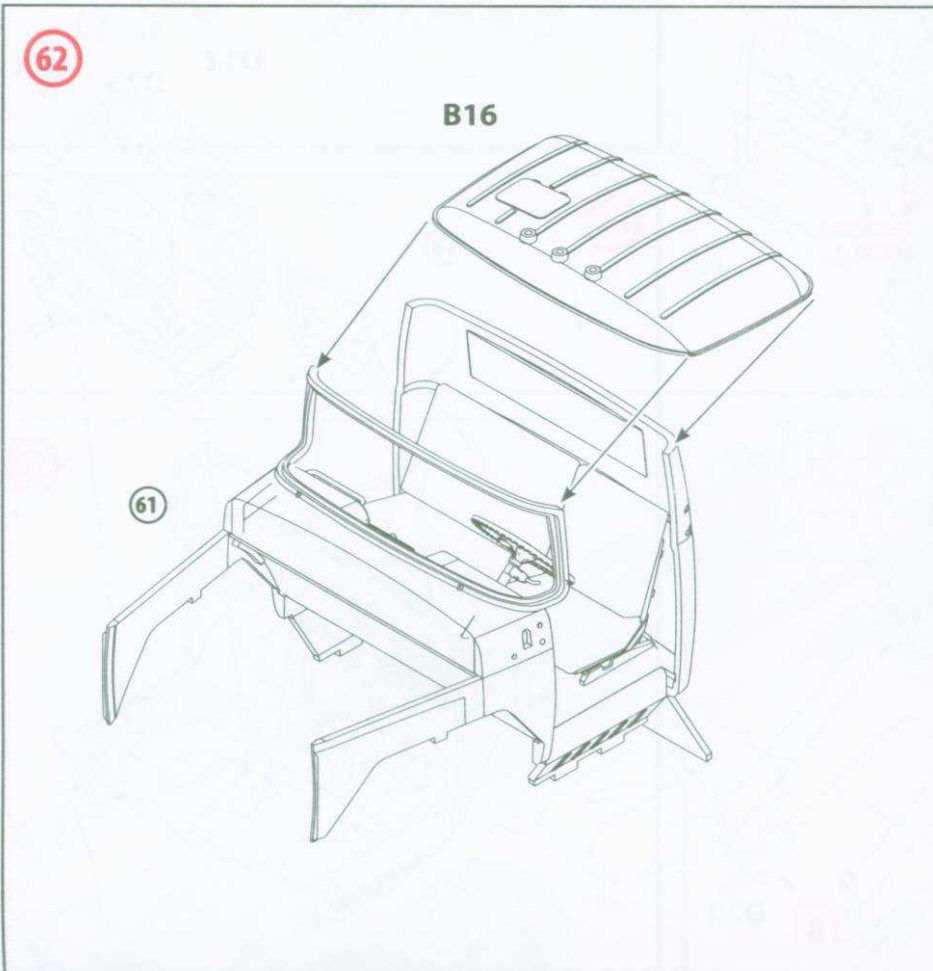
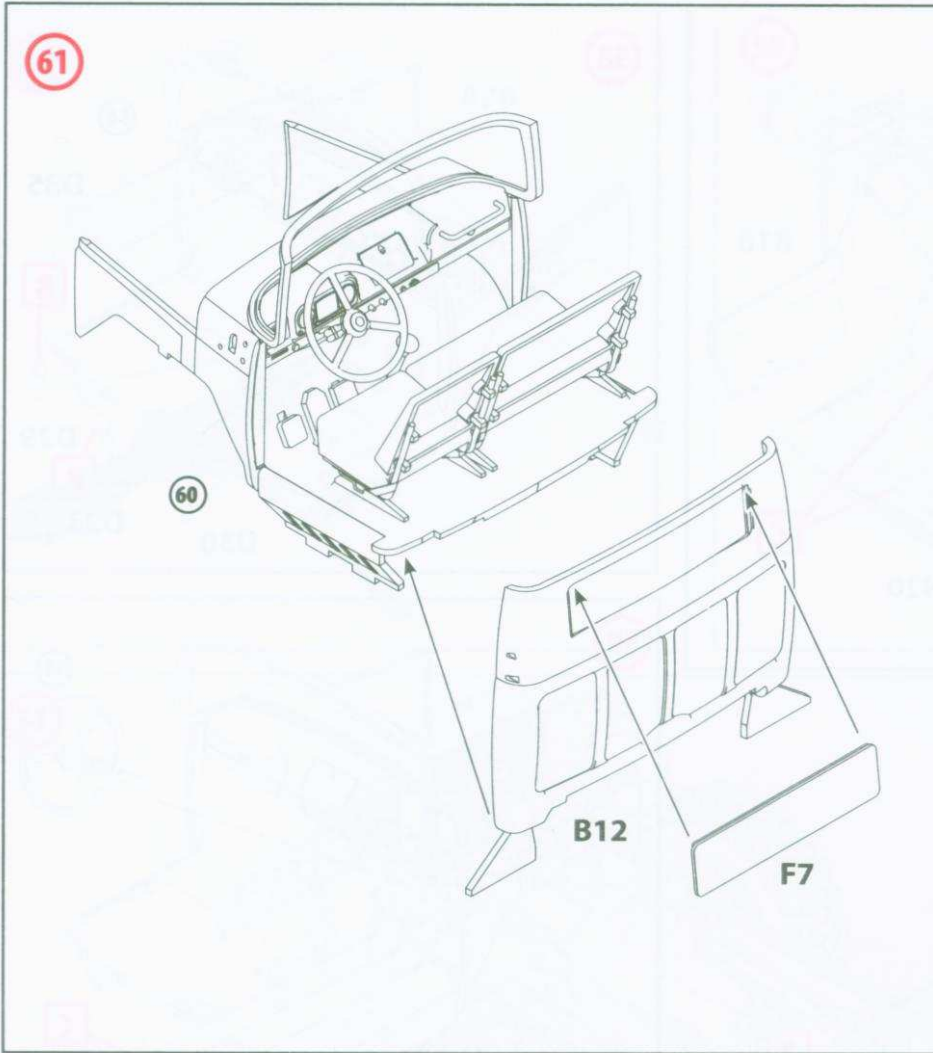

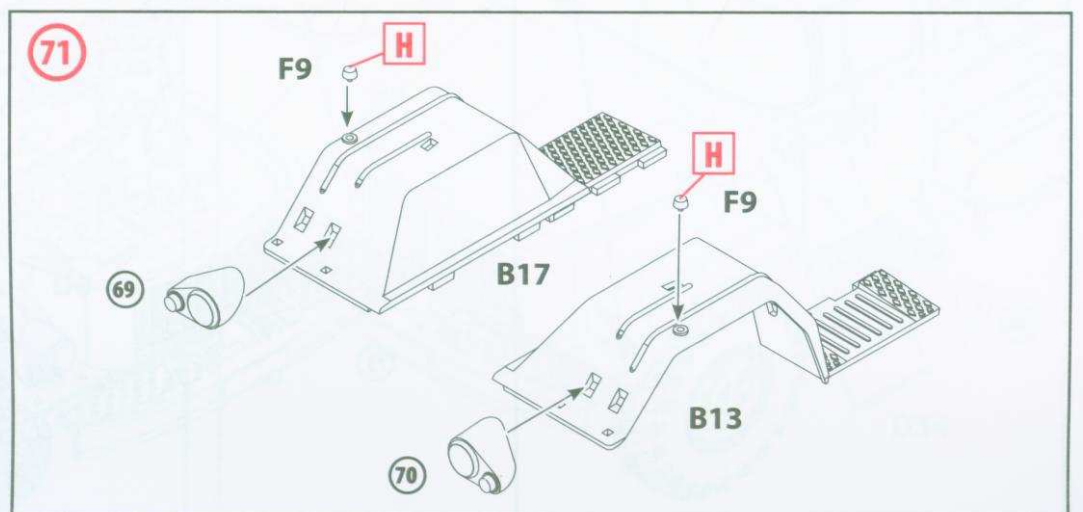
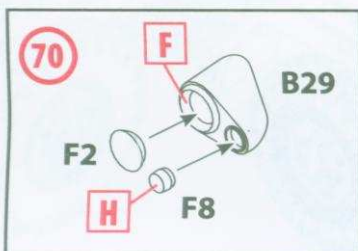
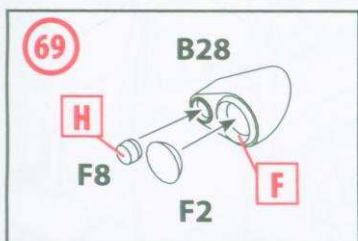
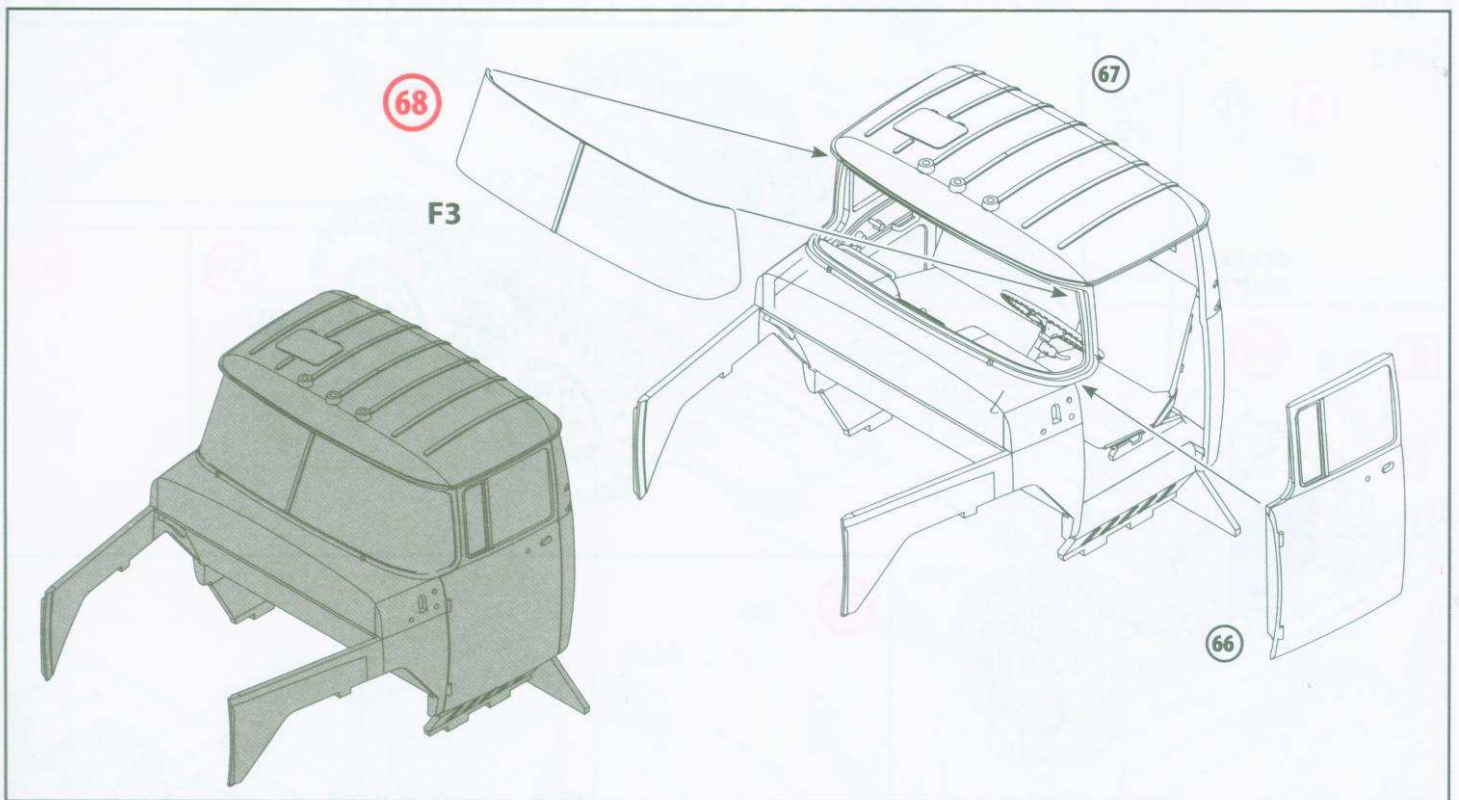
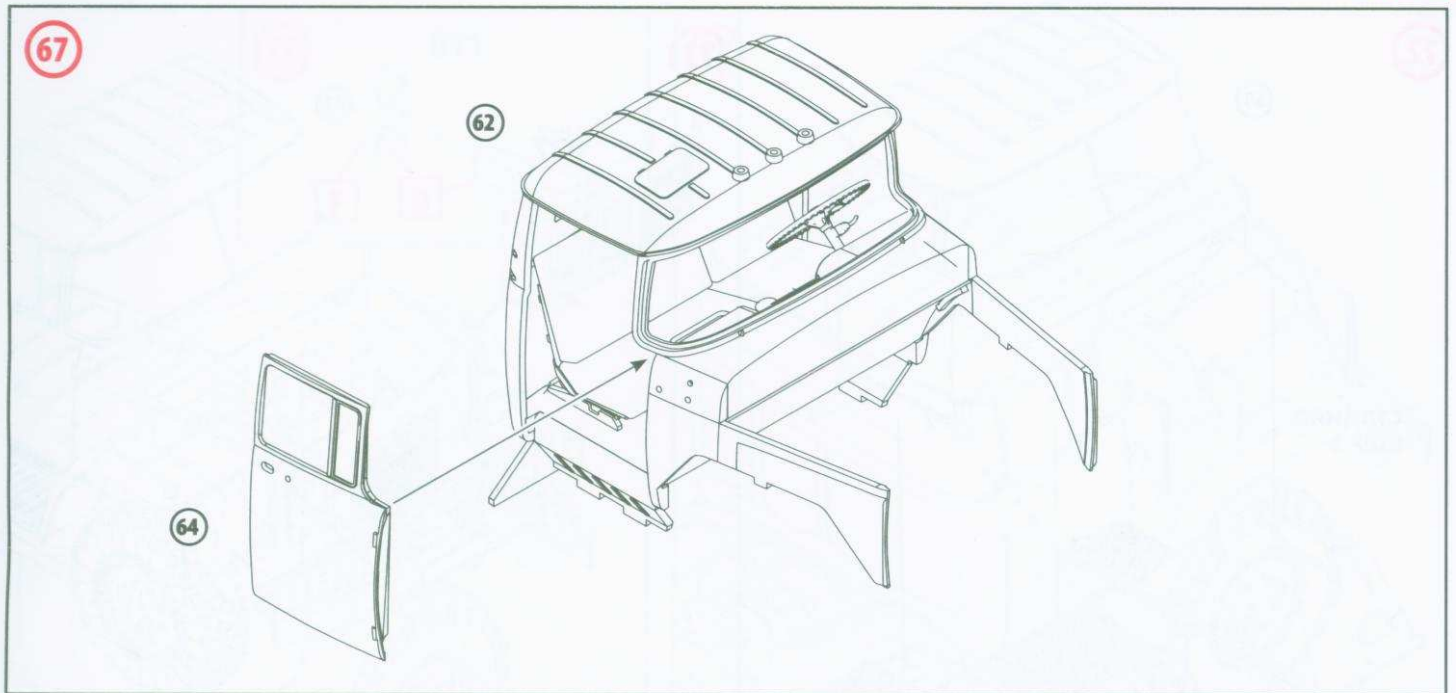

72

68

СТАДИЯ 2
STEP 2

71

71

СТАДИЯ 1
STEP 1

73

B27

72

52

74

B6

F4

H

73

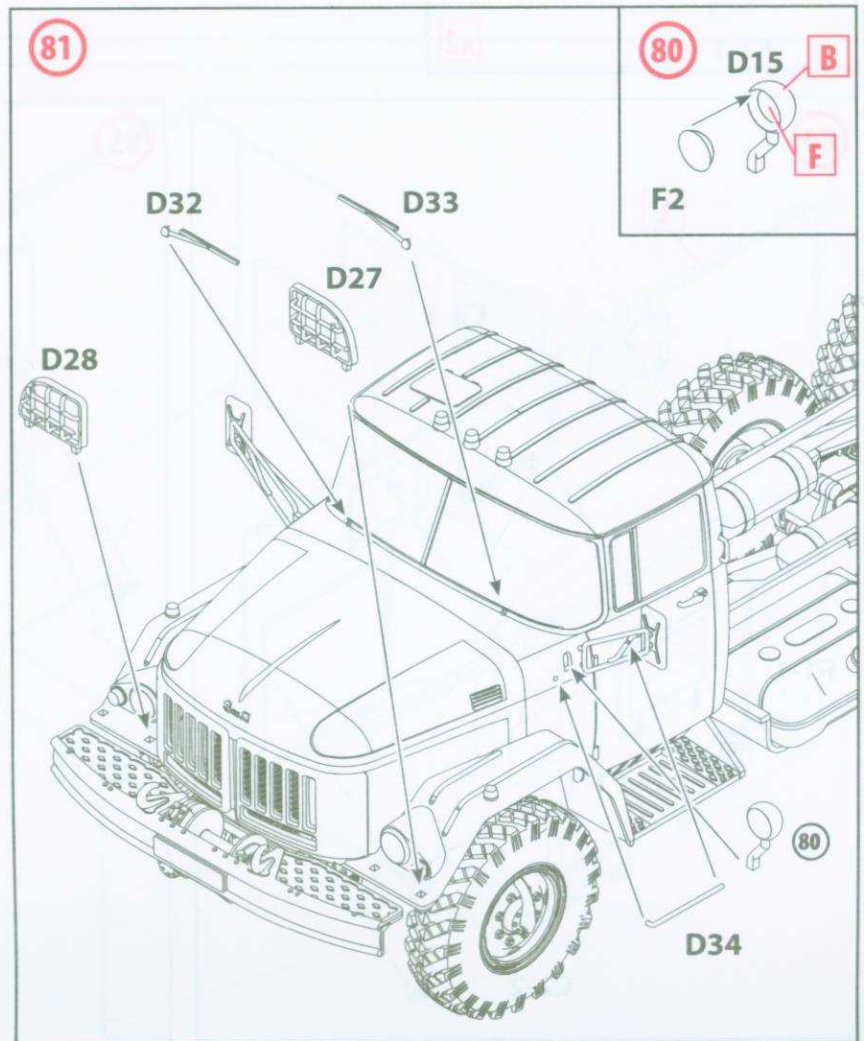
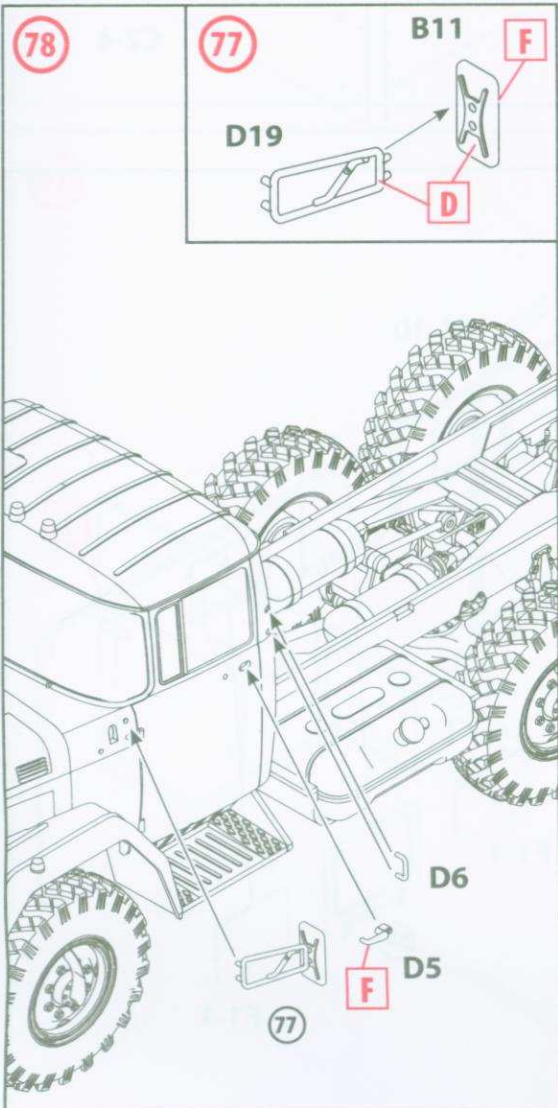
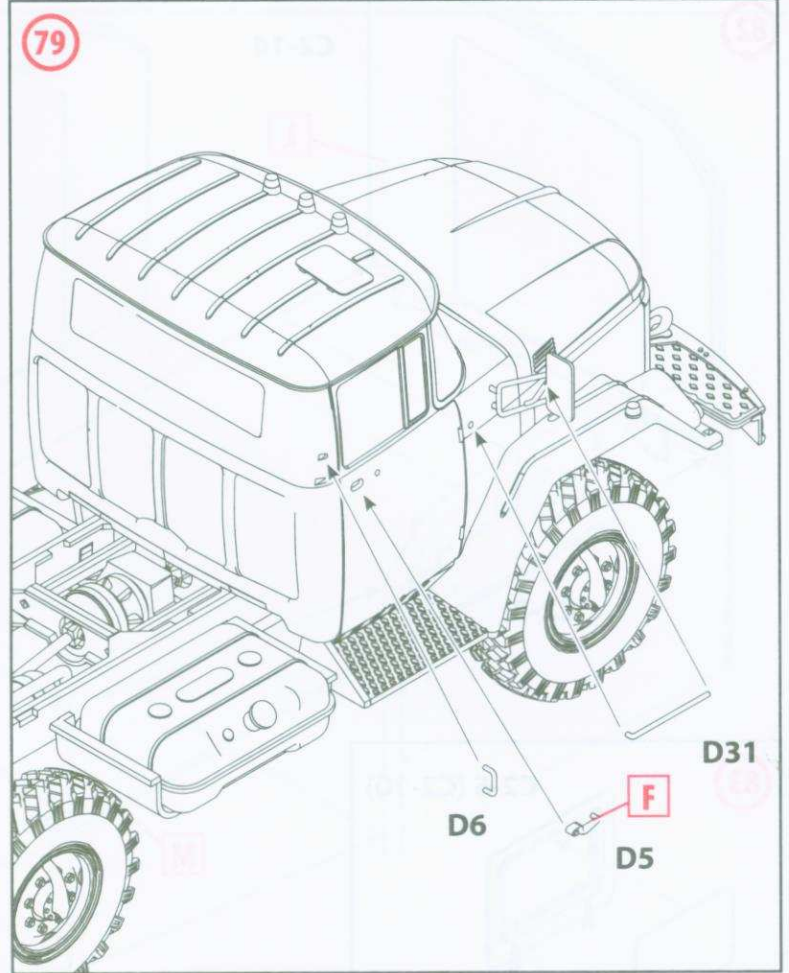
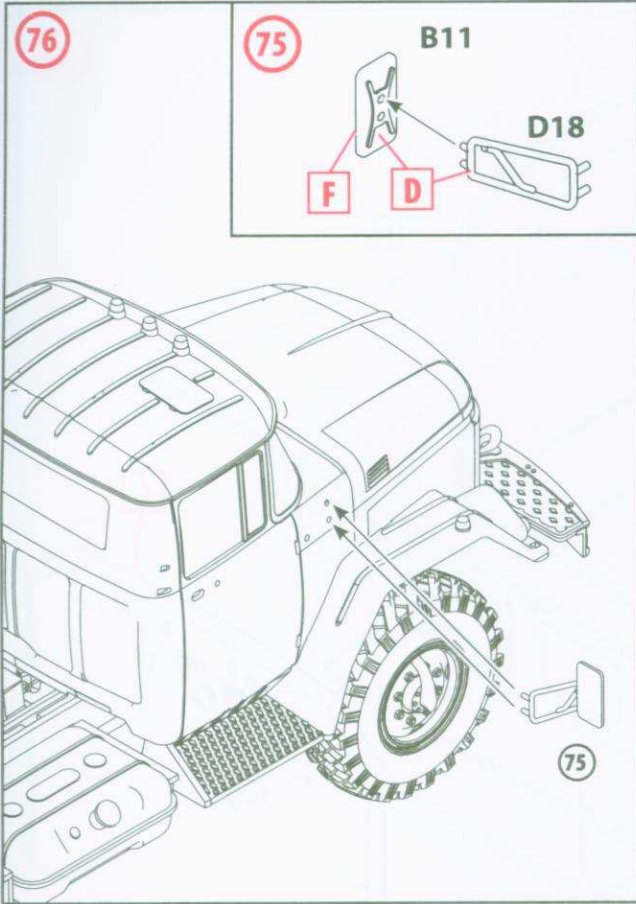

82

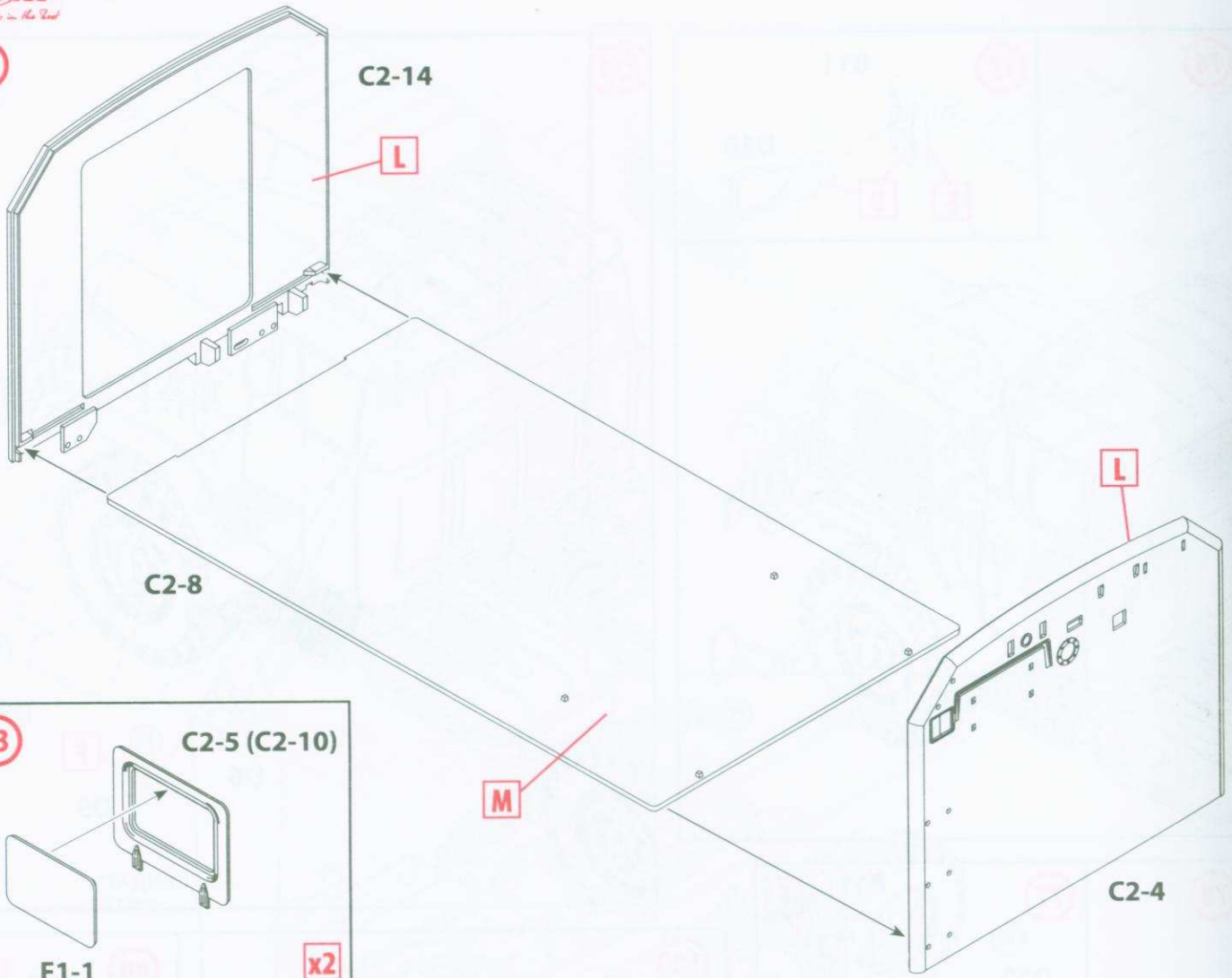

83

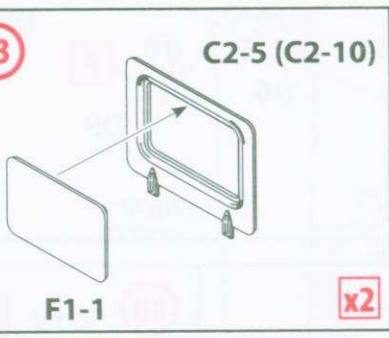

84

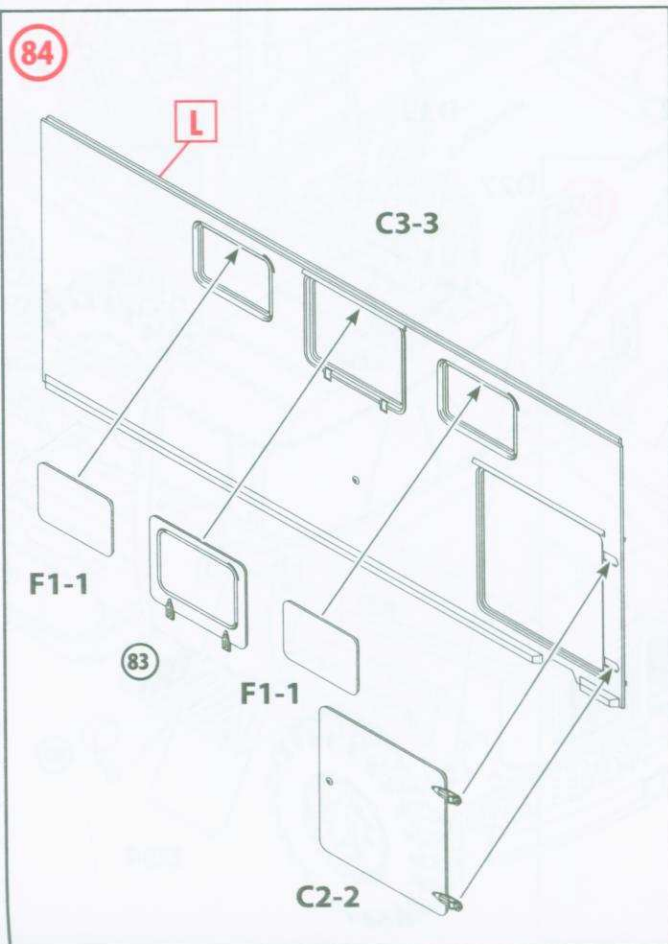

85

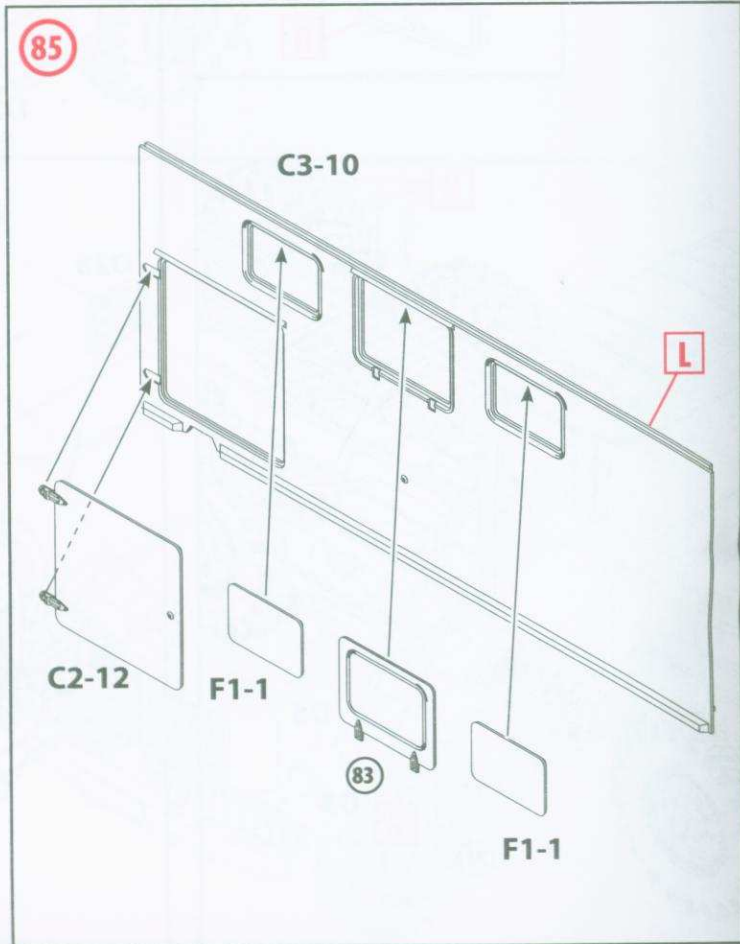

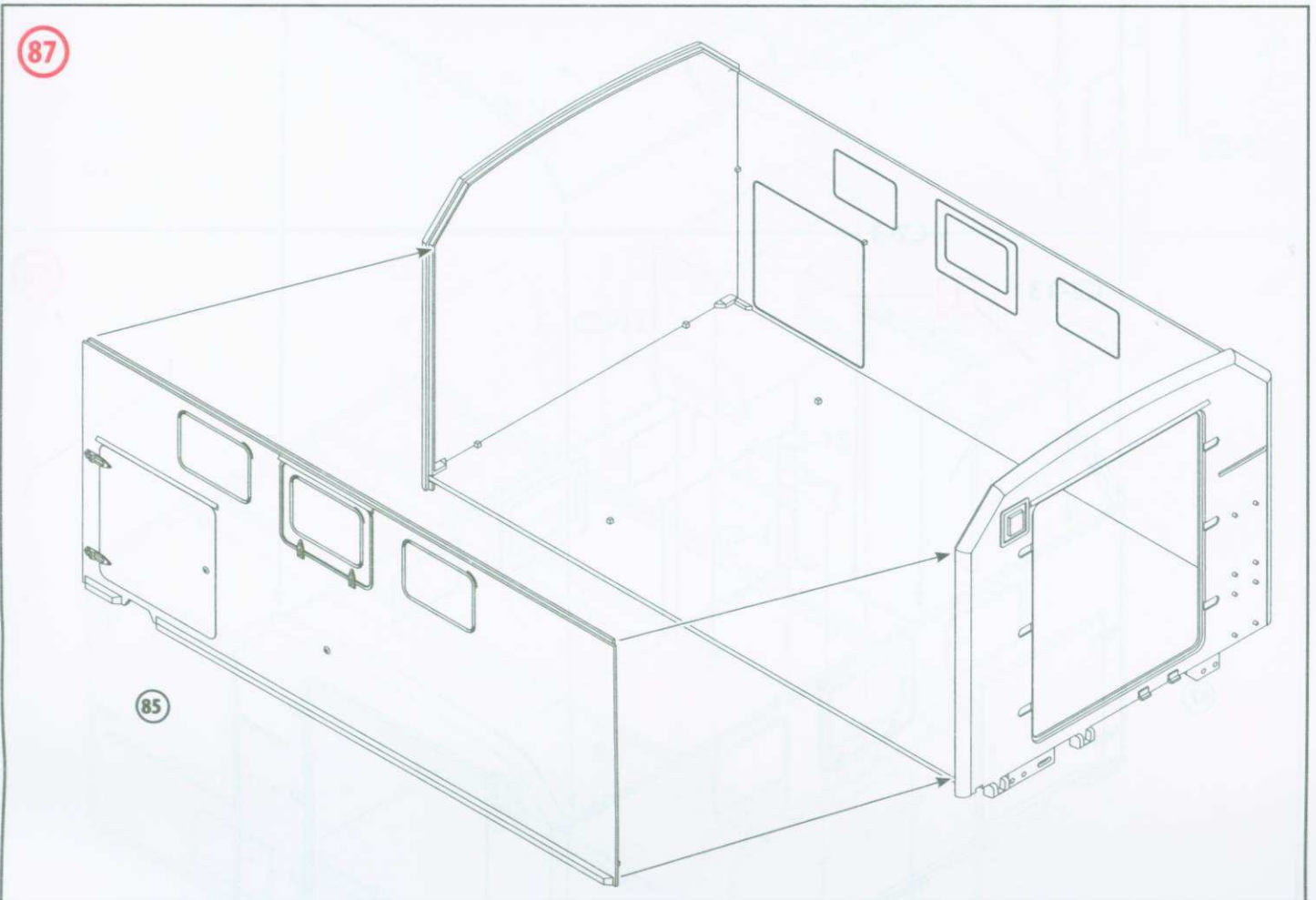
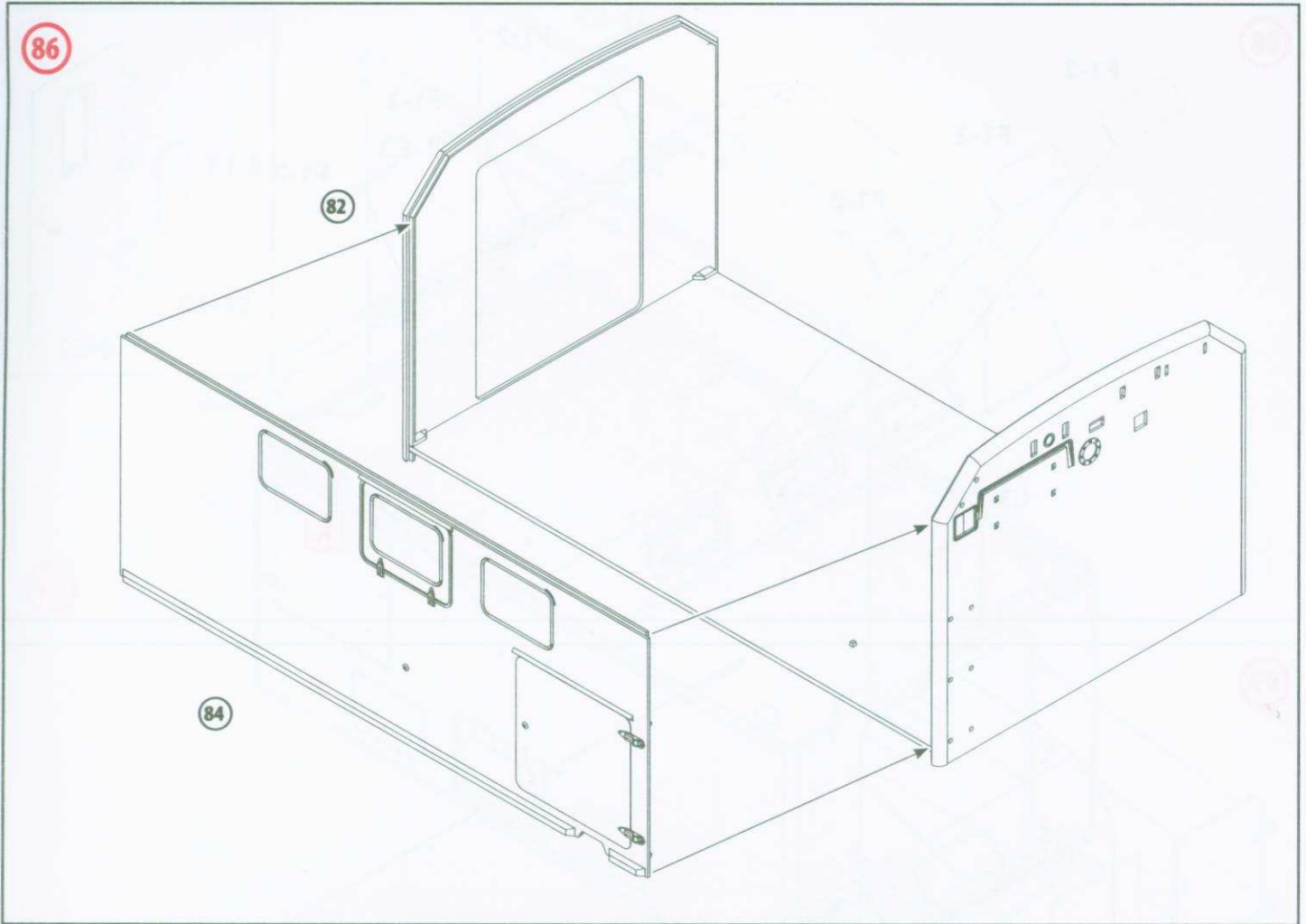

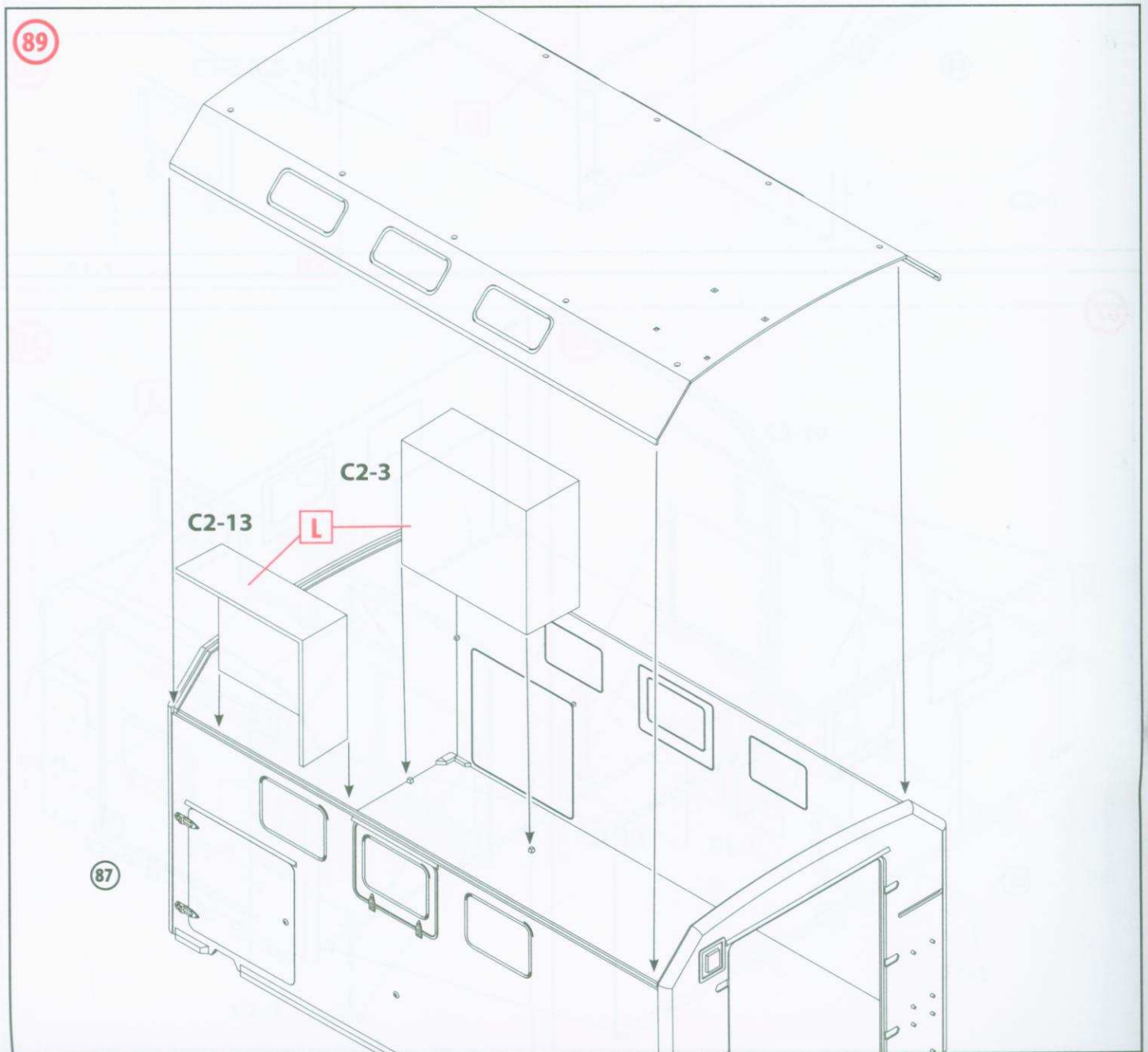
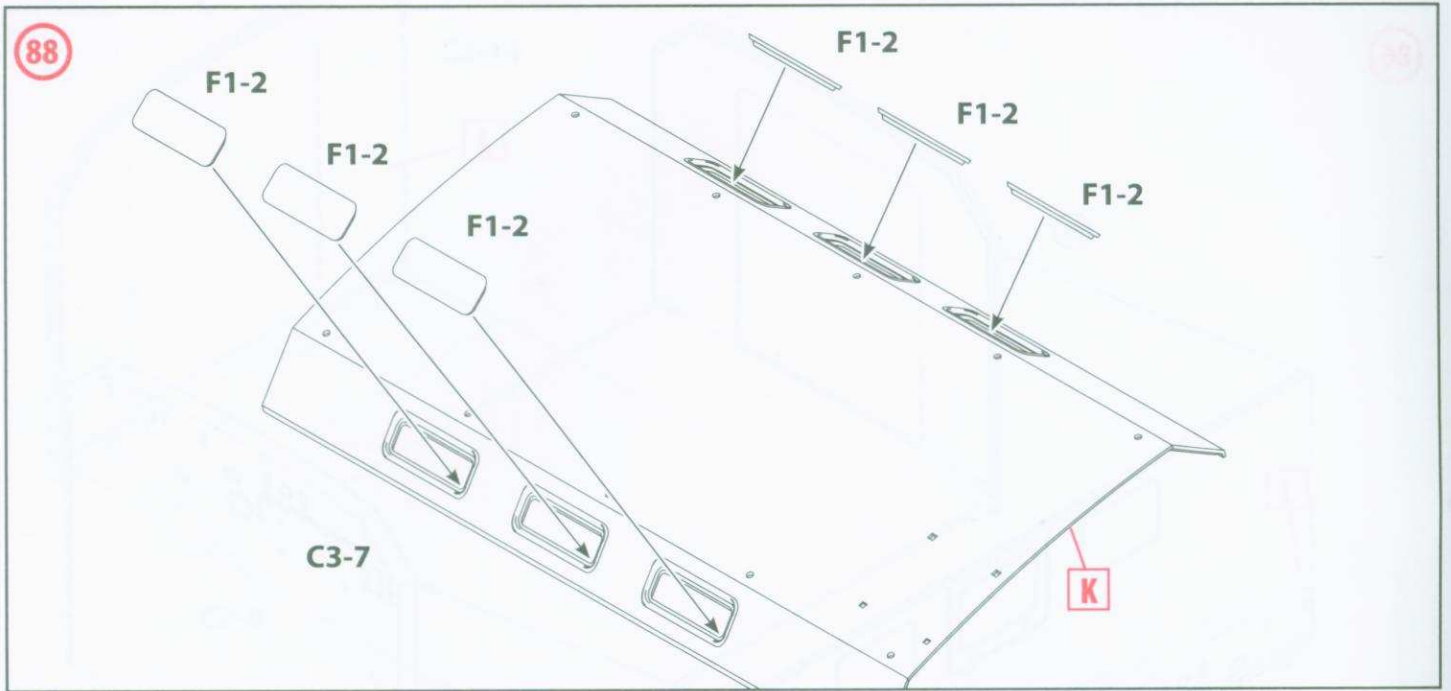

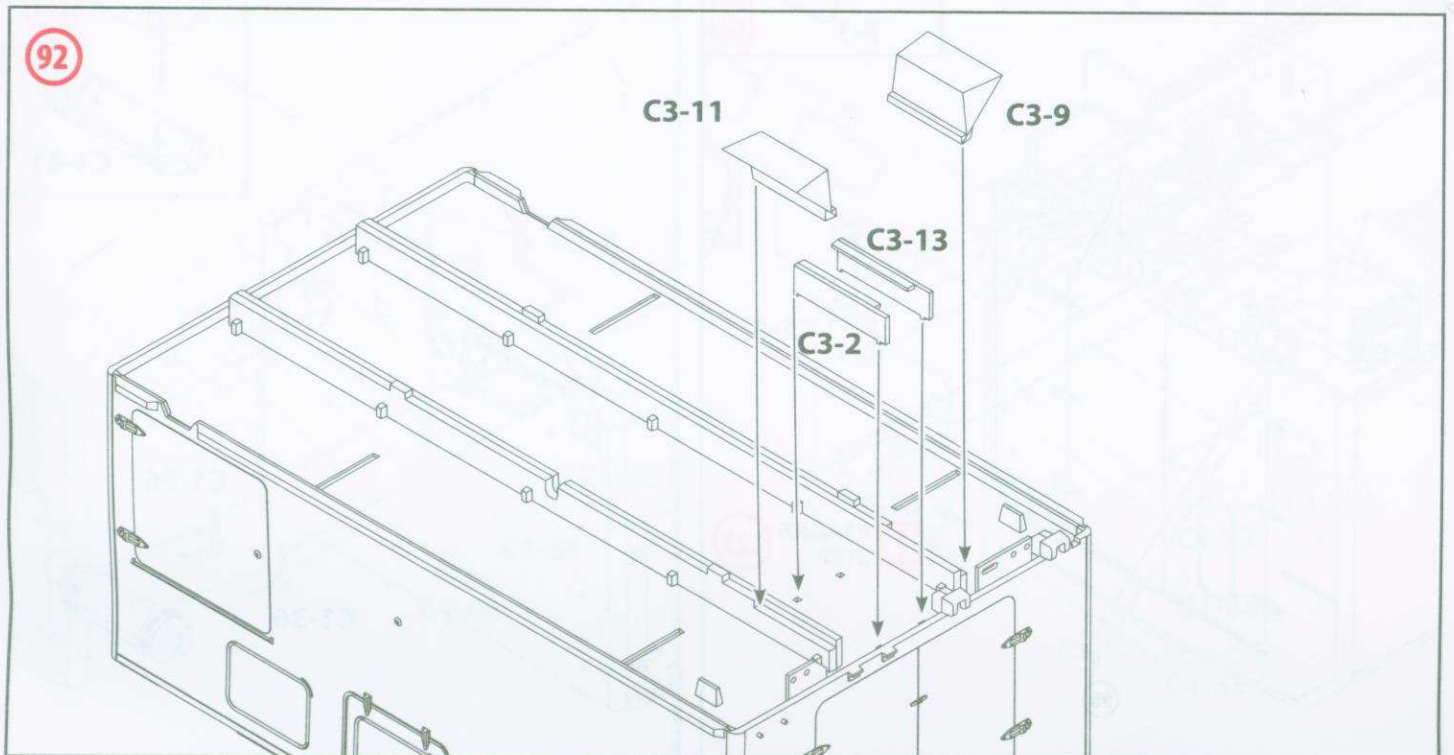
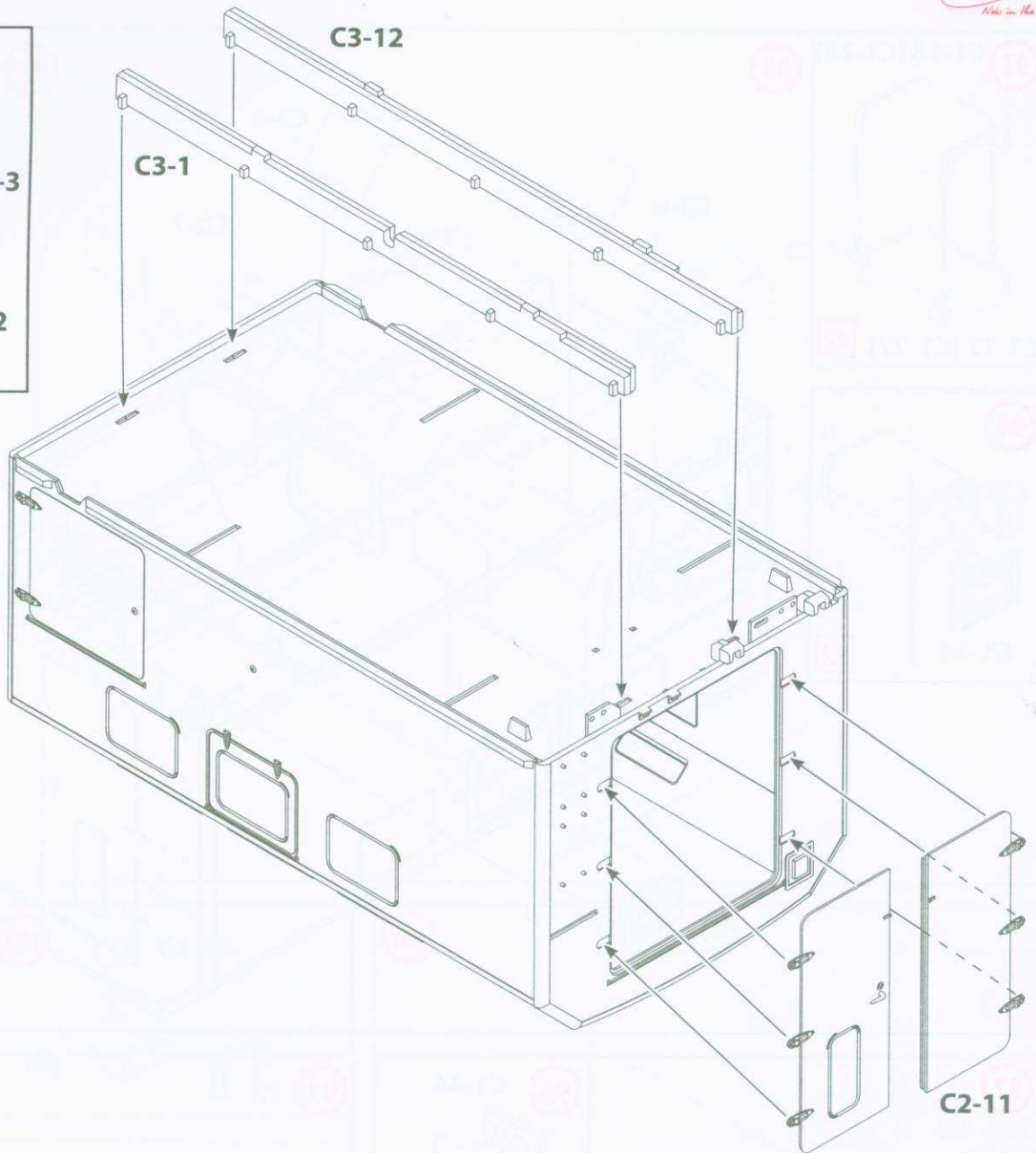
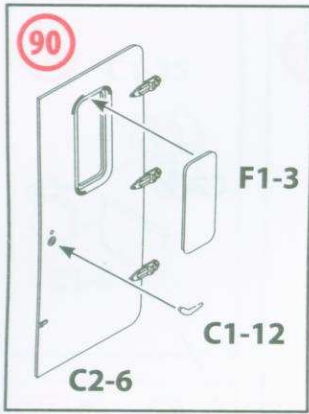

93 C1-18 (C1-28)

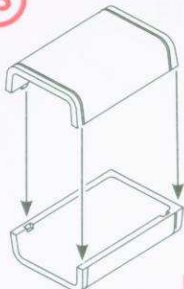

C1-17 (C1-27) **x2**

95

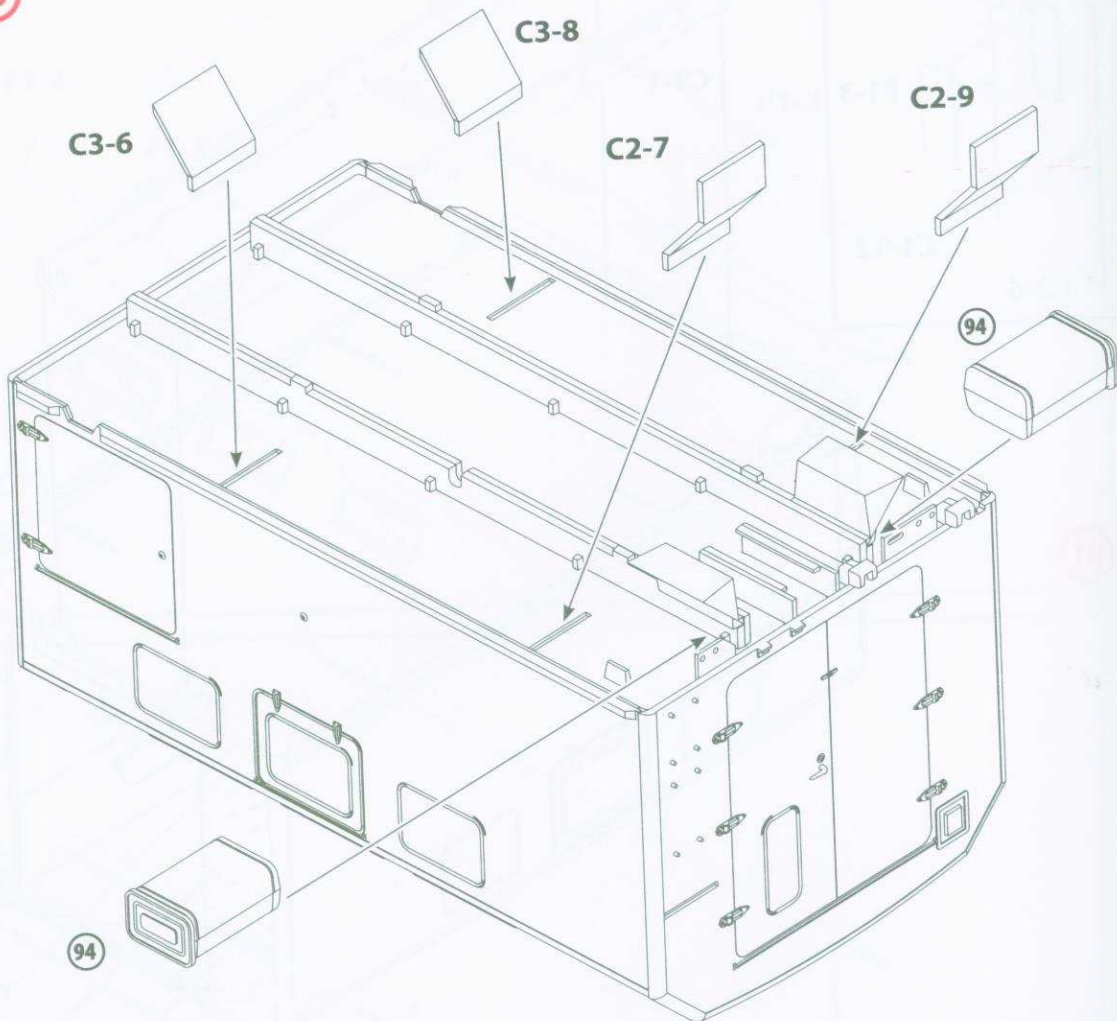

94

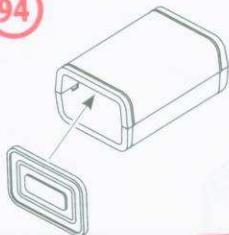

C1-14 **x2**

98 C1-29

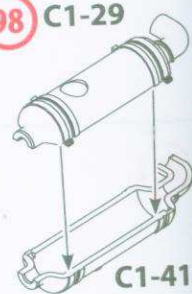

C1-41

97

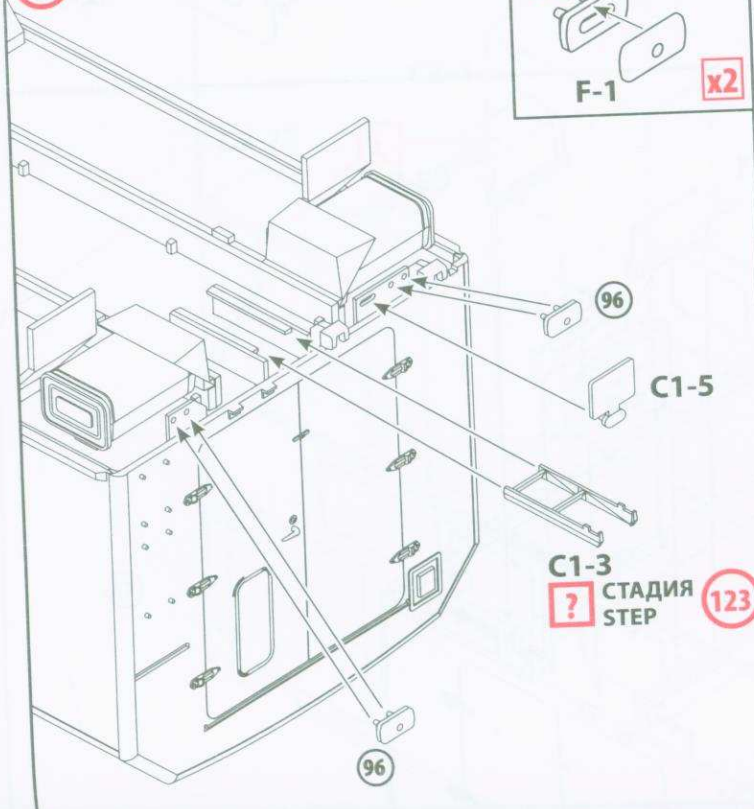

96 C1-44



F-1

x2

C1-5

C1-3 **?** СТАДИЯ STEP **123**

99

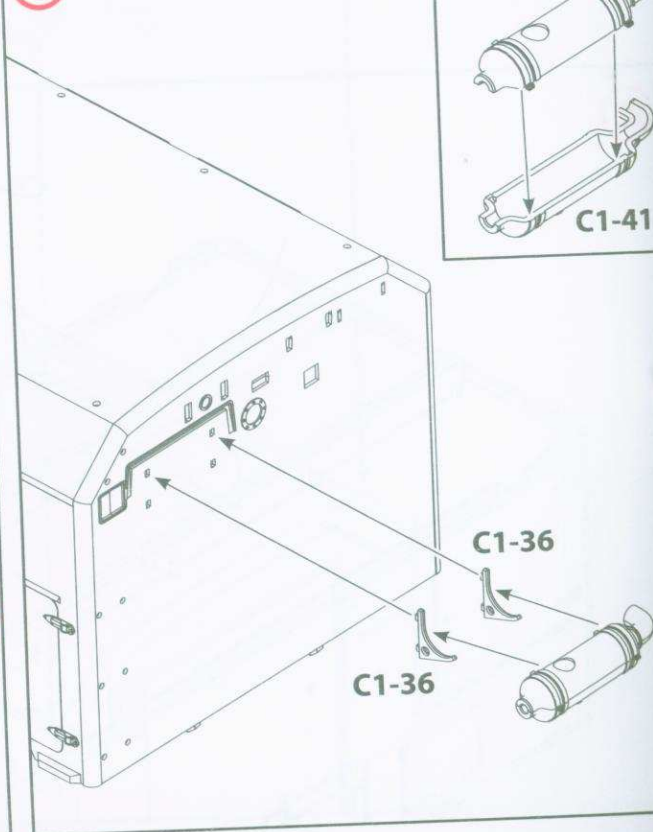

C1-36

C1-36

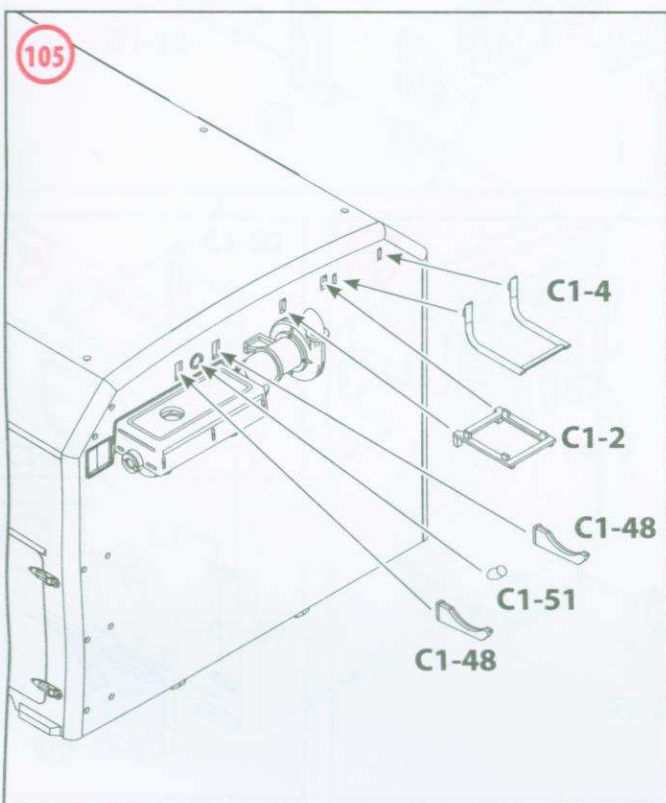
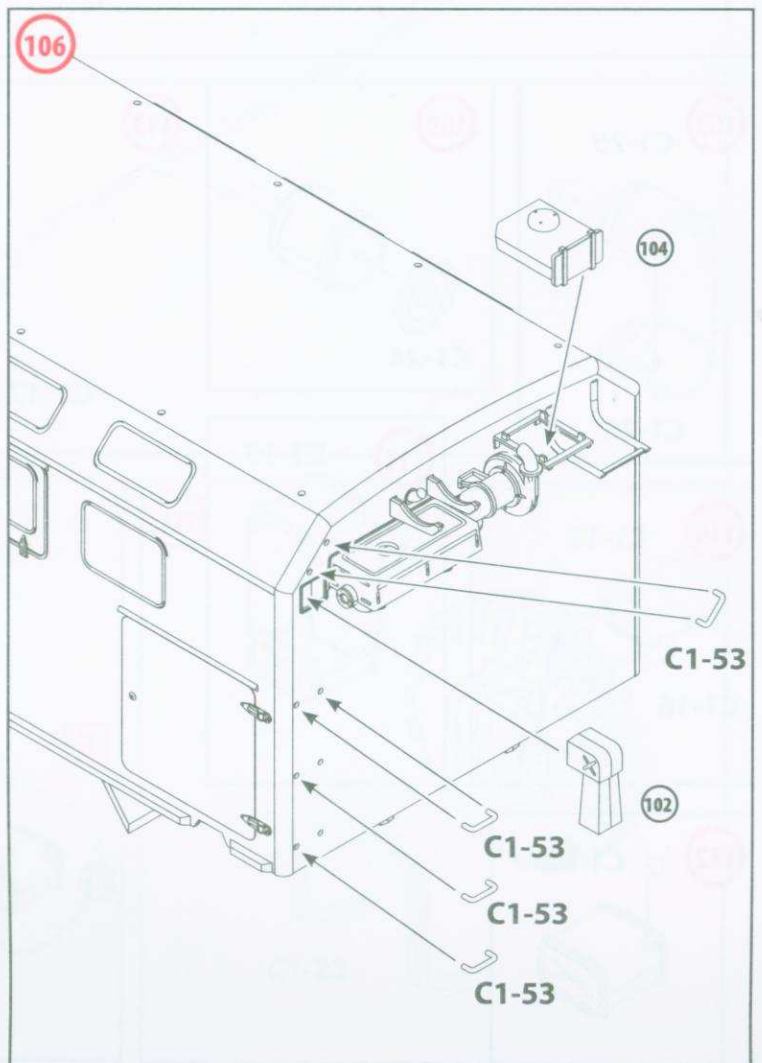
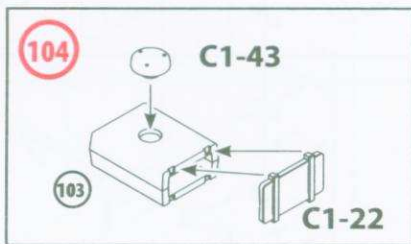
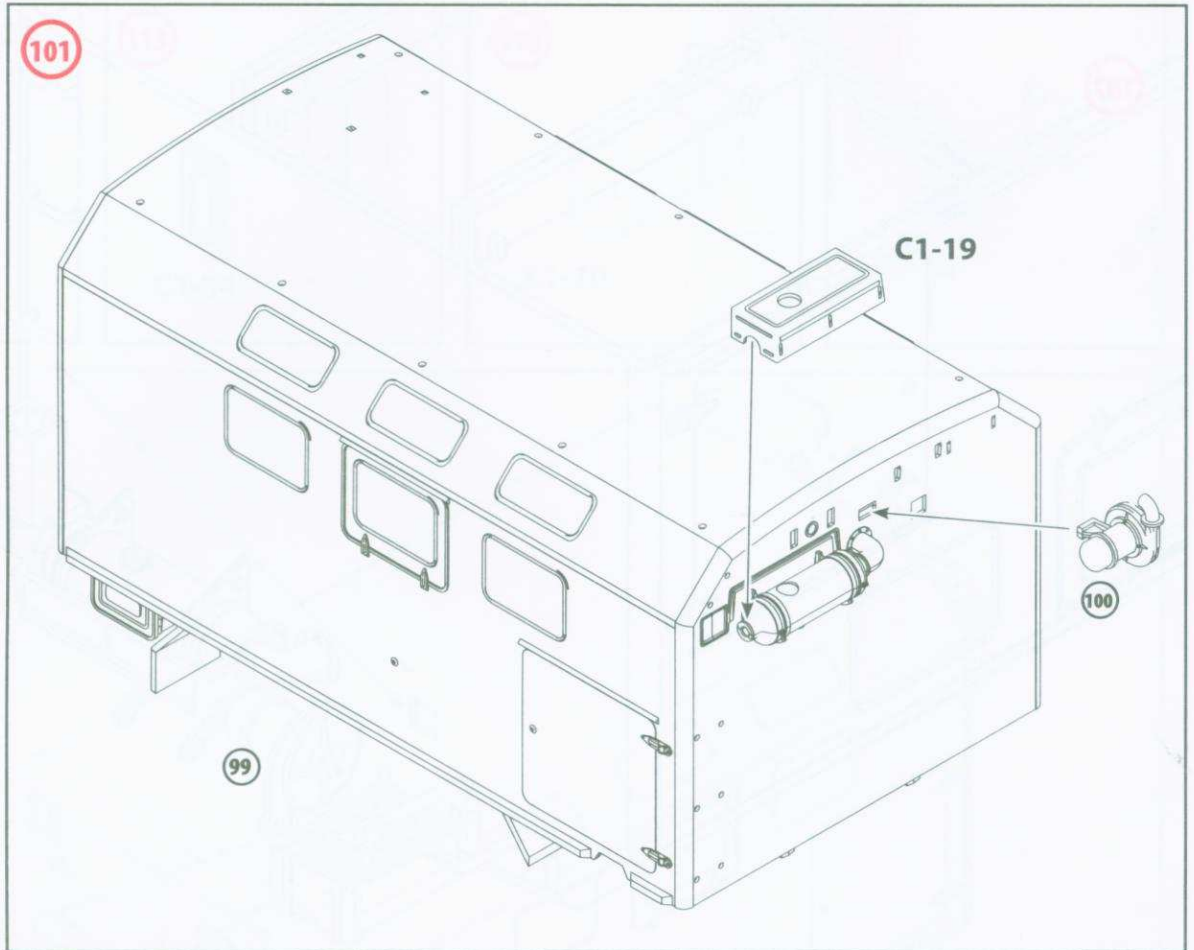
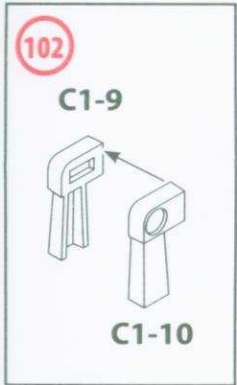

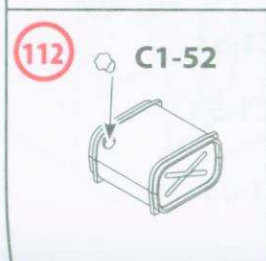
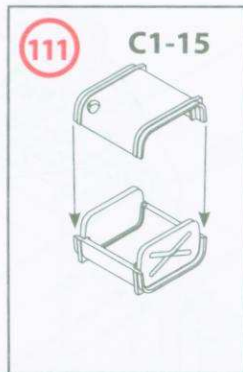
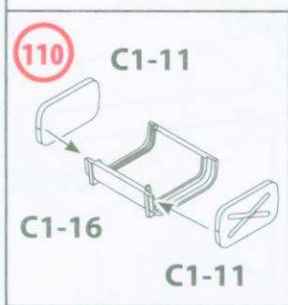
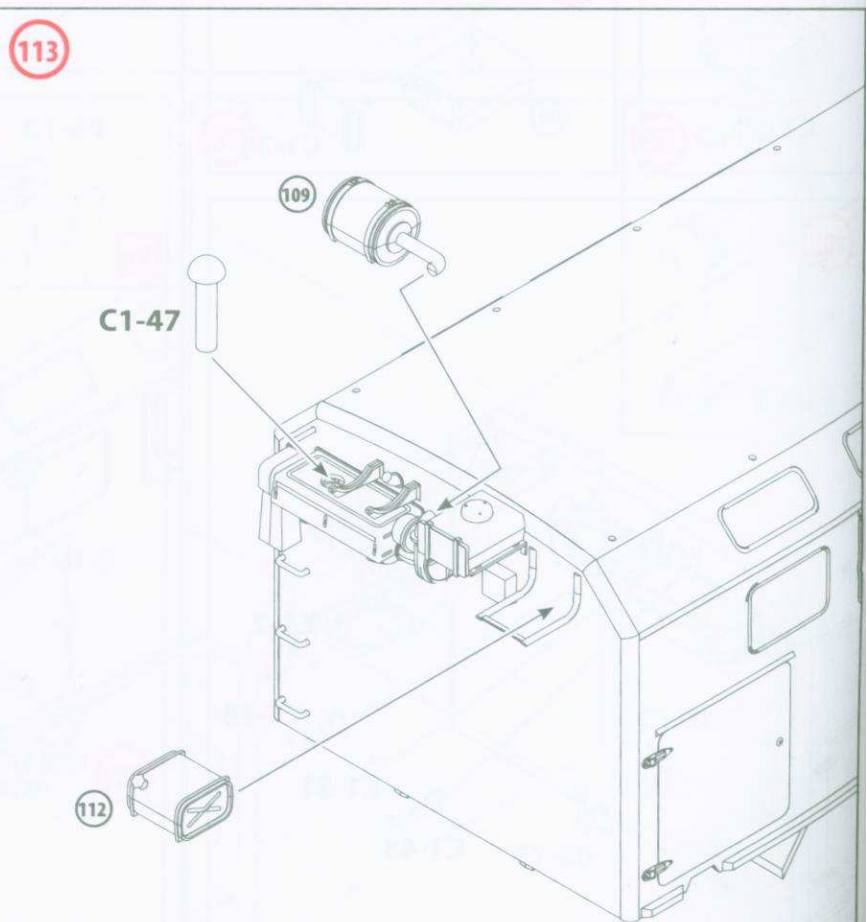
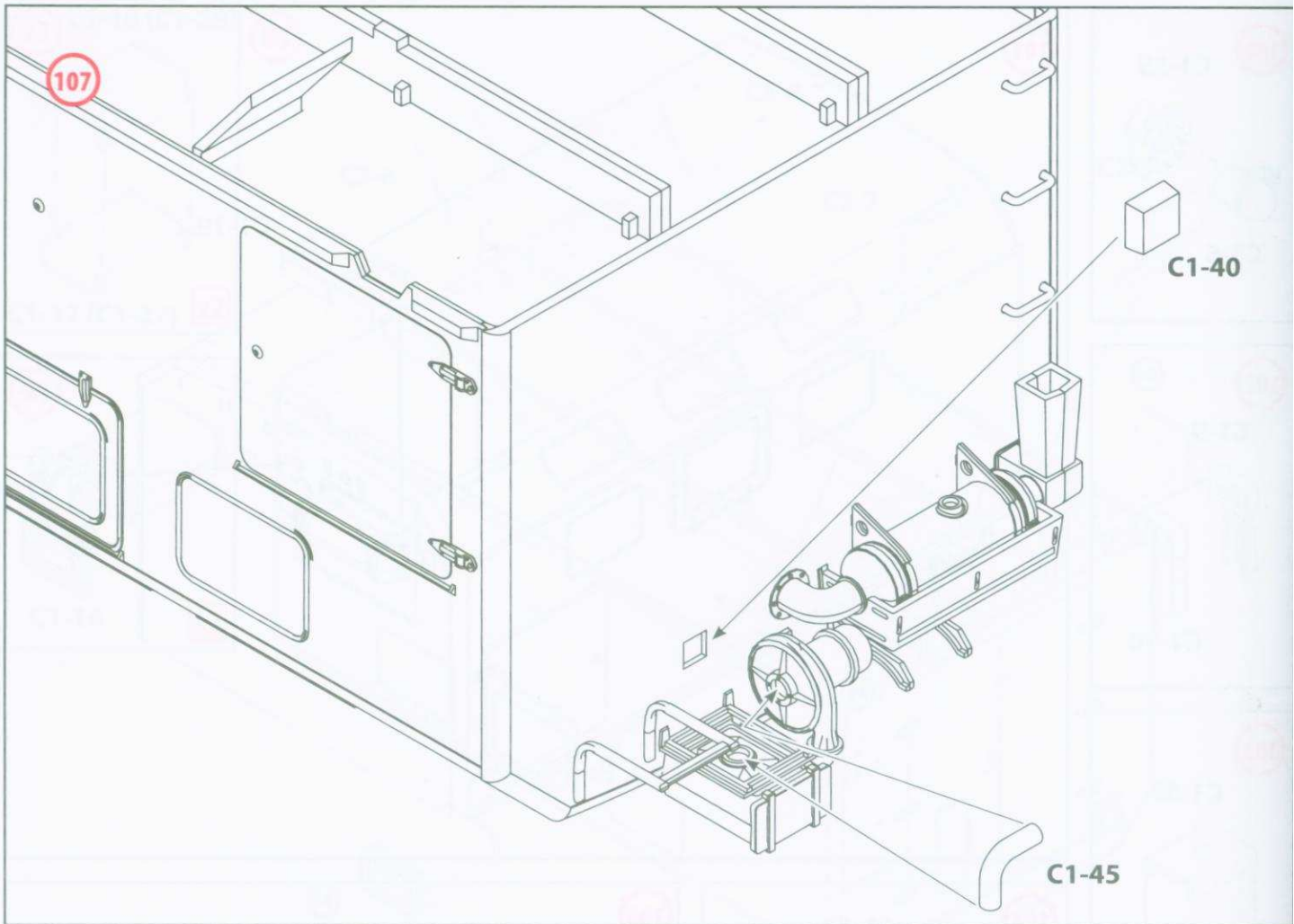

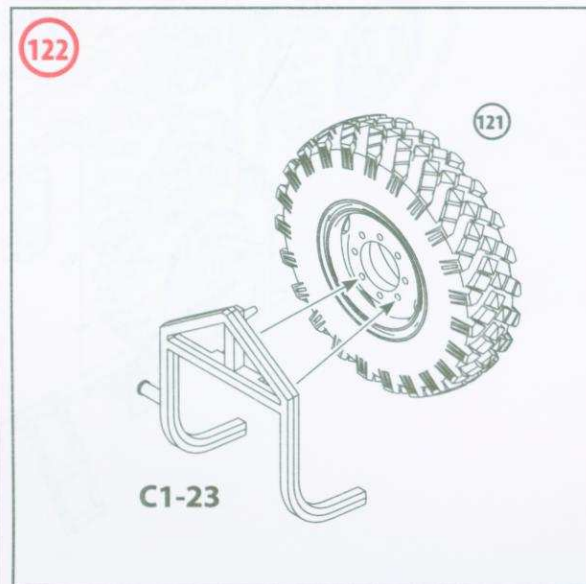
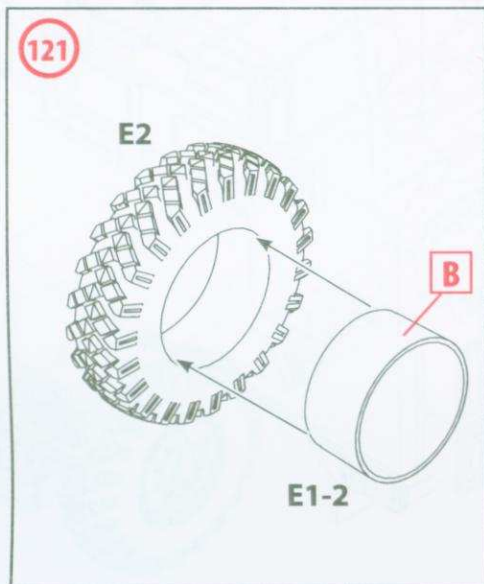
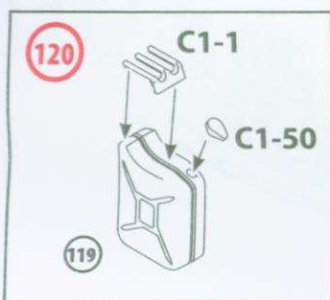
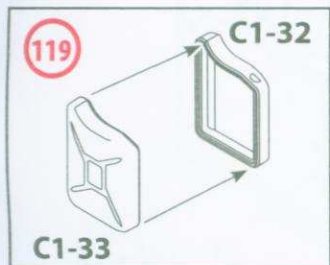
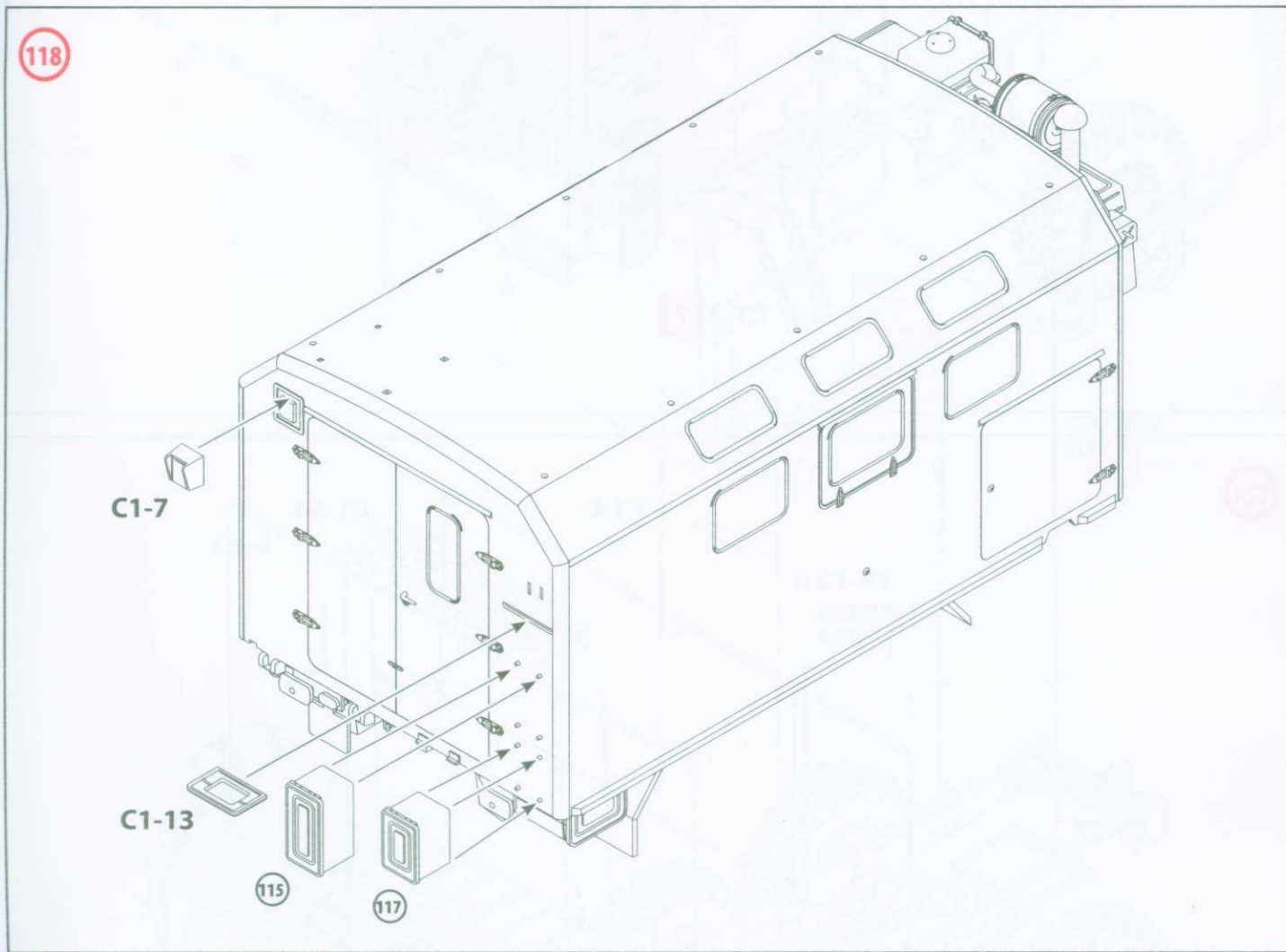
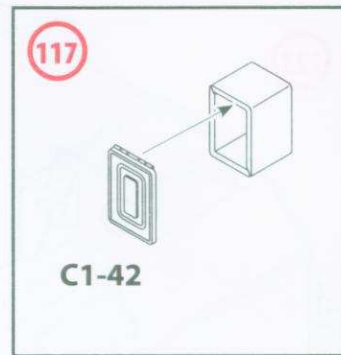
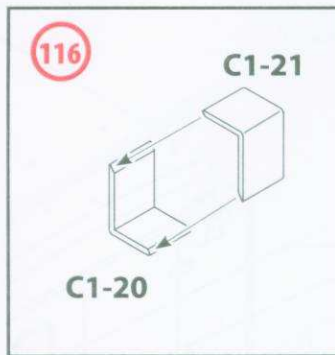
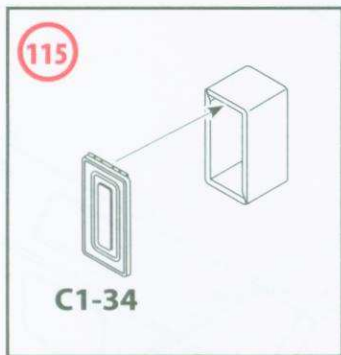
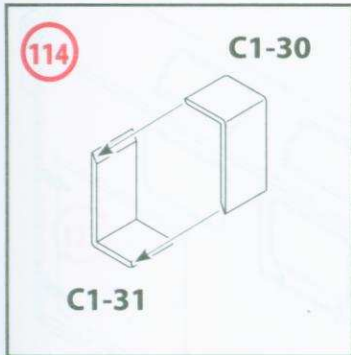

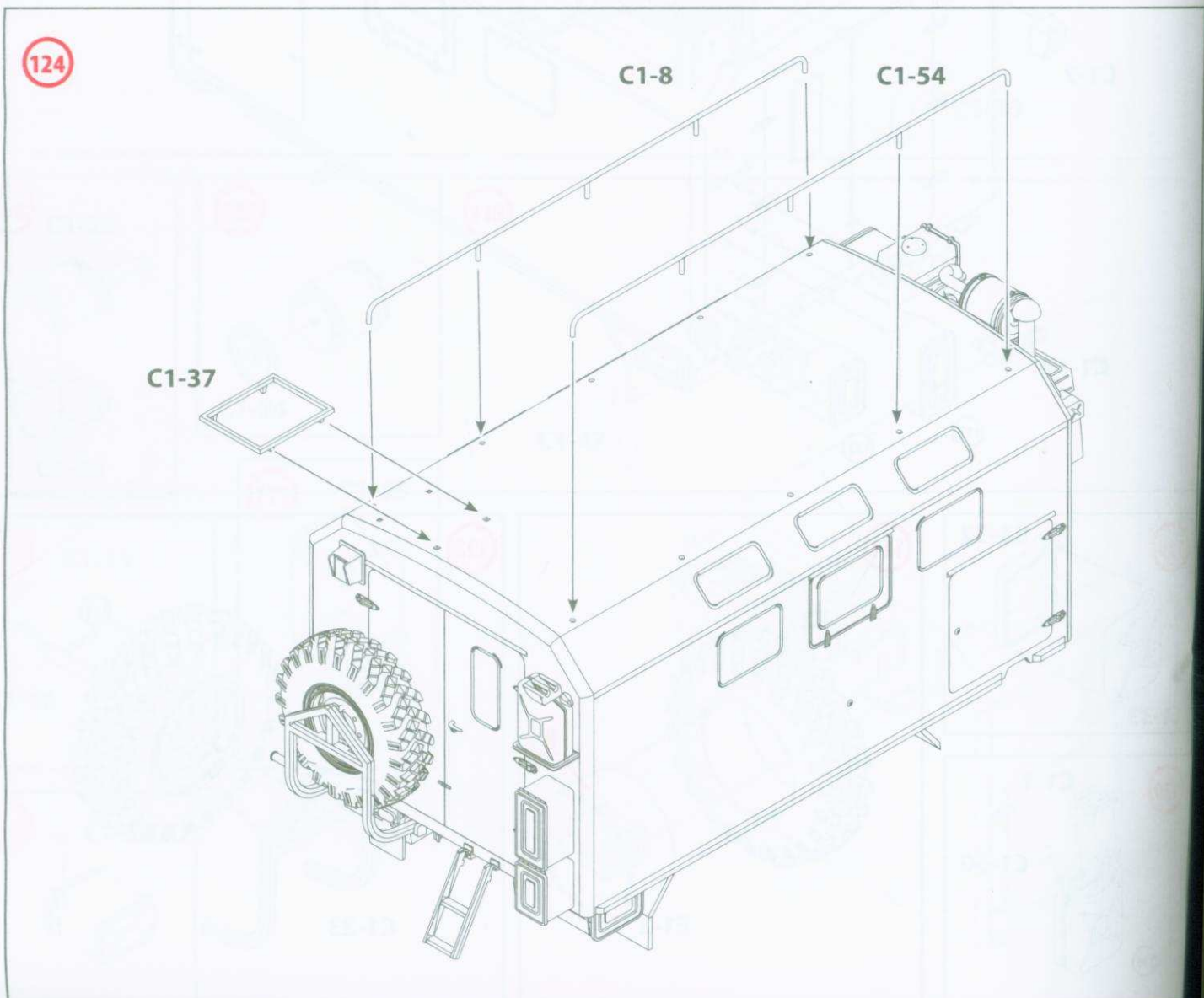
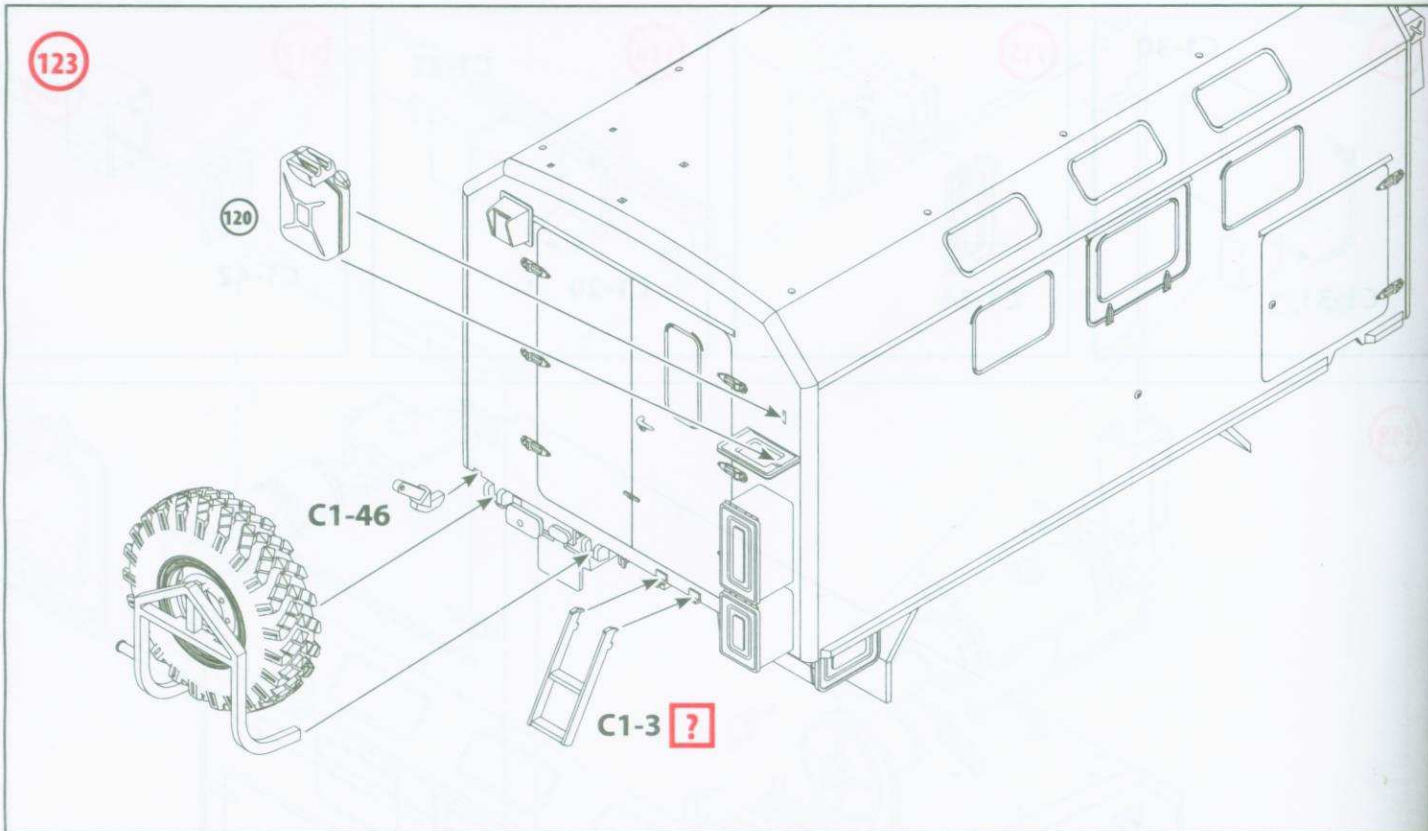

125

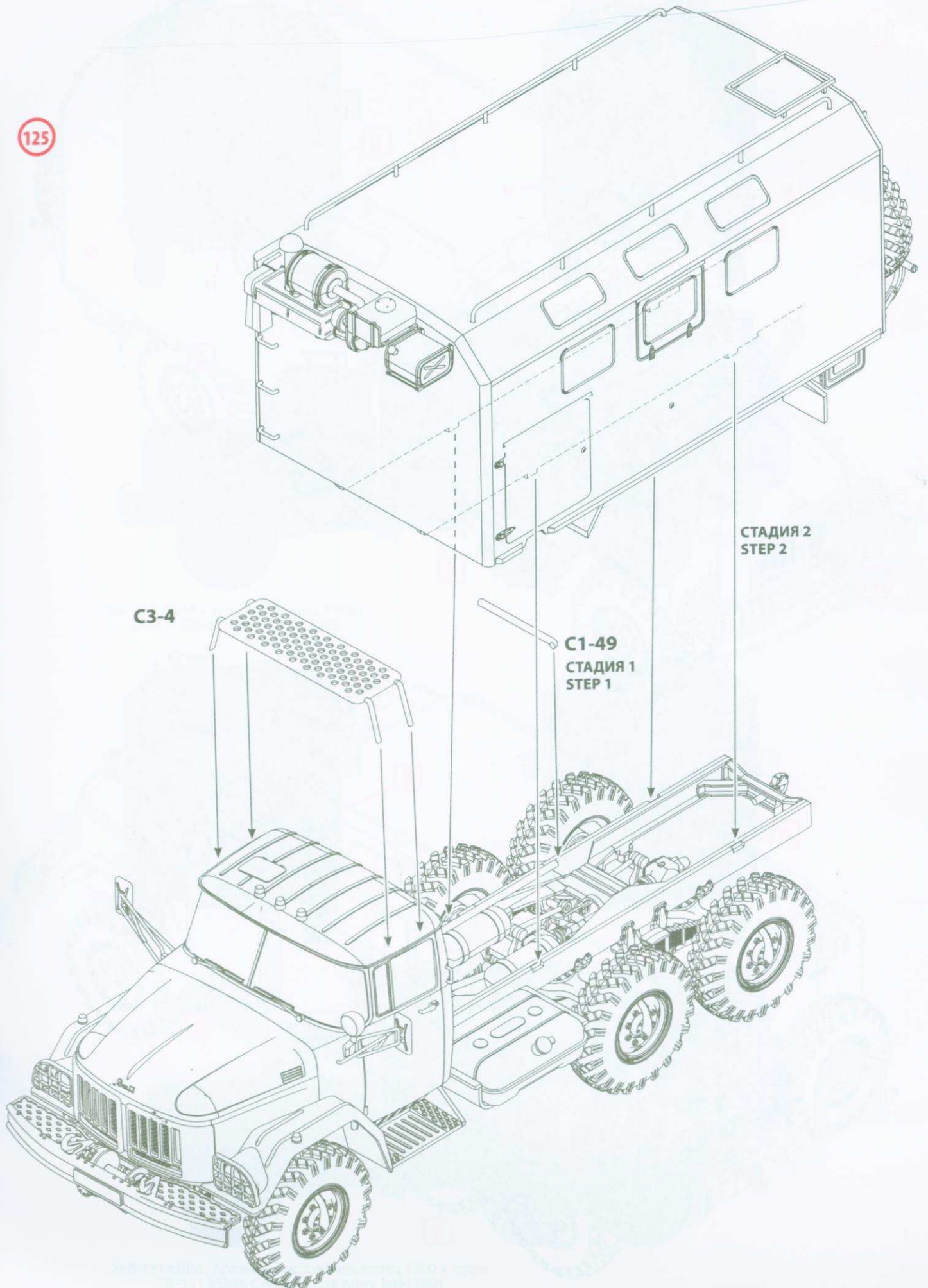

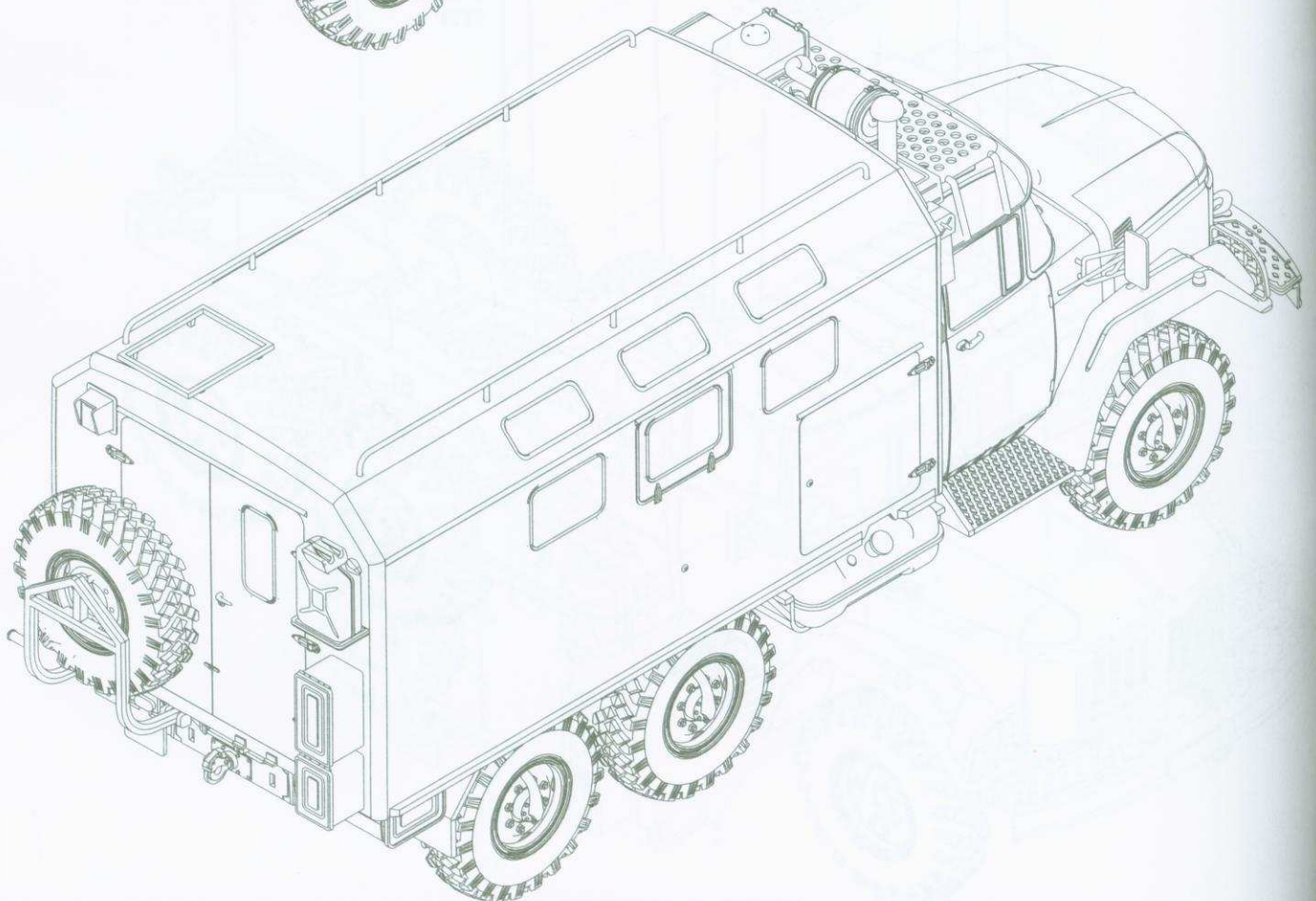
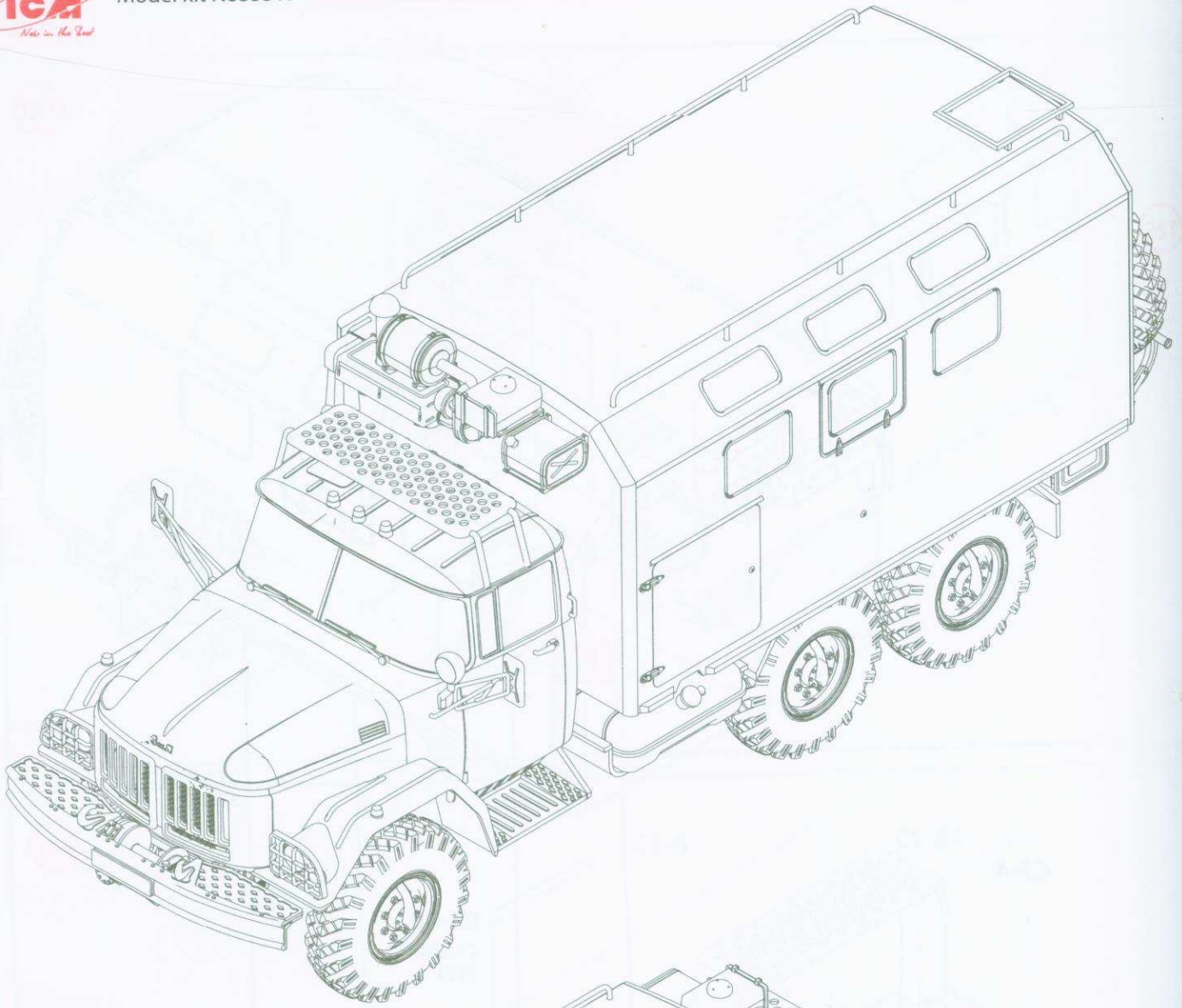

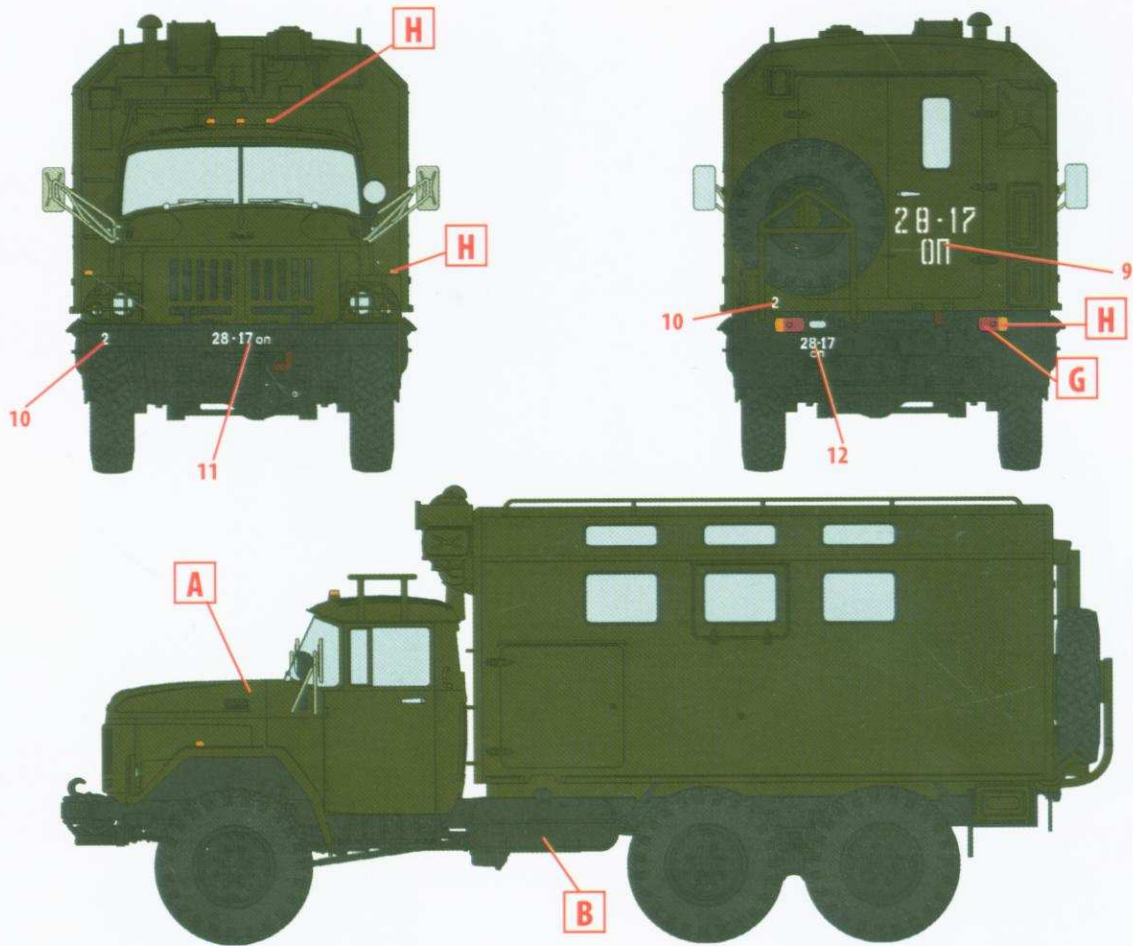

Зил-131 КШМ, Советская Армия, 1986 г.
 ZiL-131 KShM, Soviet Army, 1986

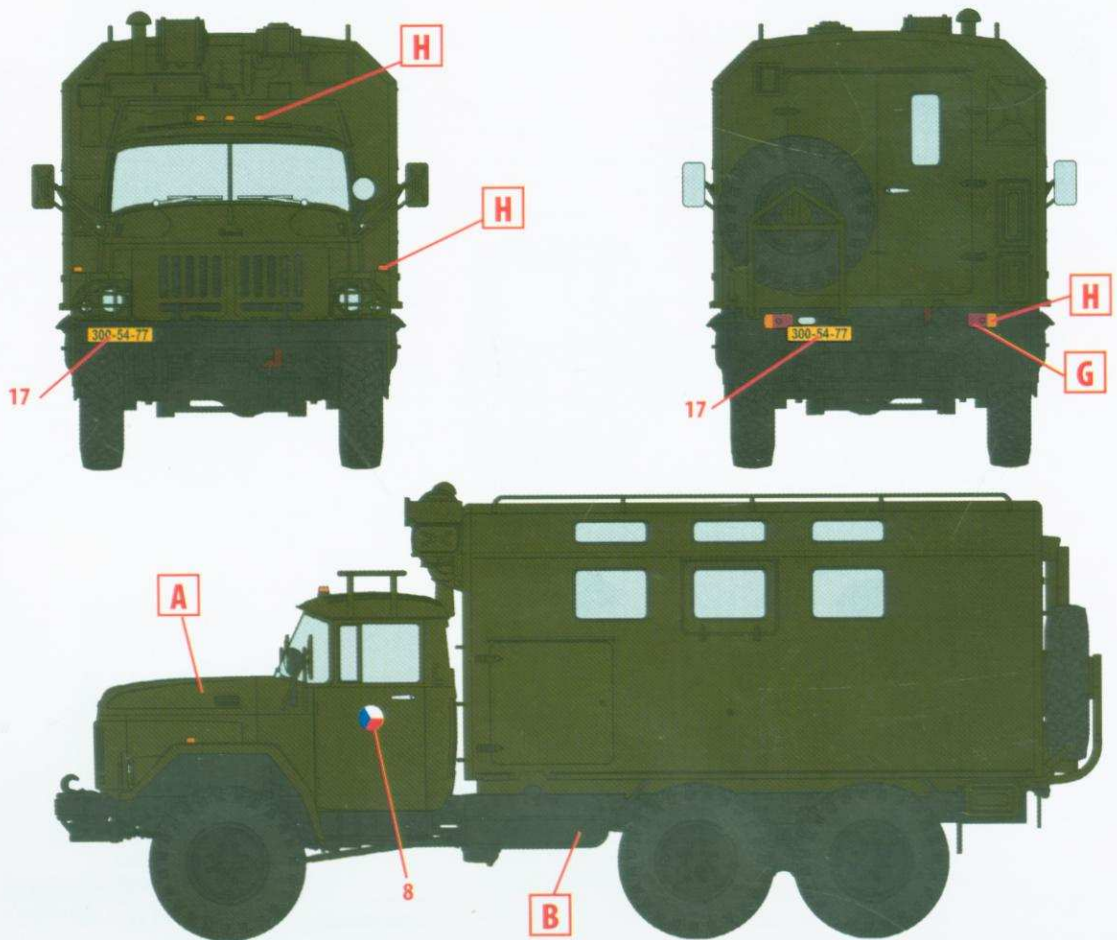

Зил-131 КШМ, Армия Чехословакии, конец 1980-х годов
 ZiL-131 KShM, Czechoslovak Army, late 1980s

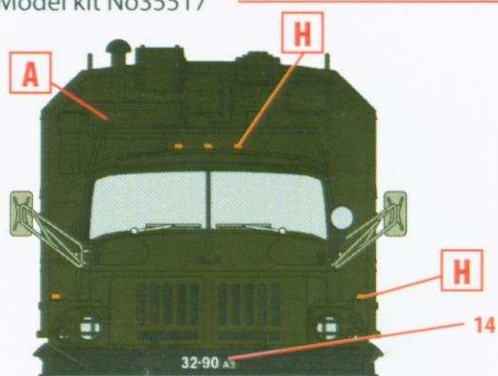

Зил-131 КШМ, Советская Армия, конец 1980-х годов
ZiL-131 KShM, Soviet Army, late 80s

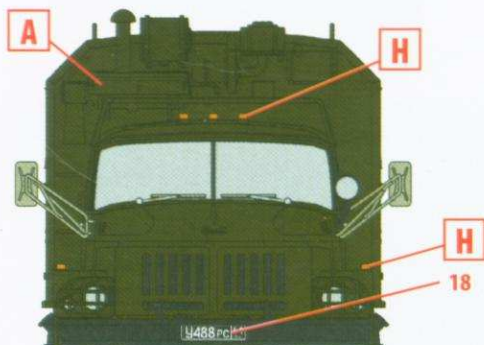
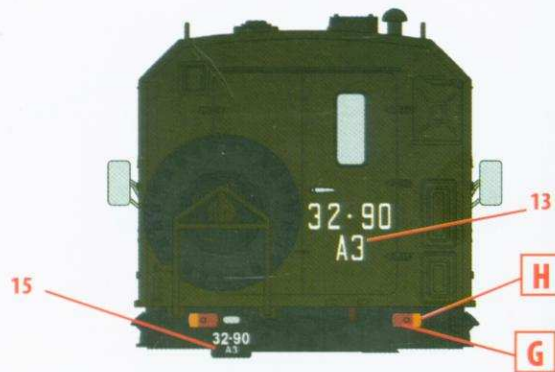

Зил-131 КШМ, армия России, конец 2000-х годов
ZiL-131 KShM, Russian Army, late 2000s

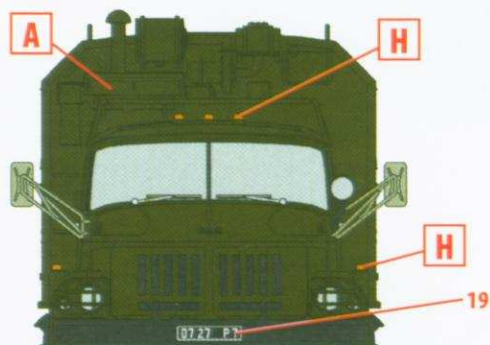
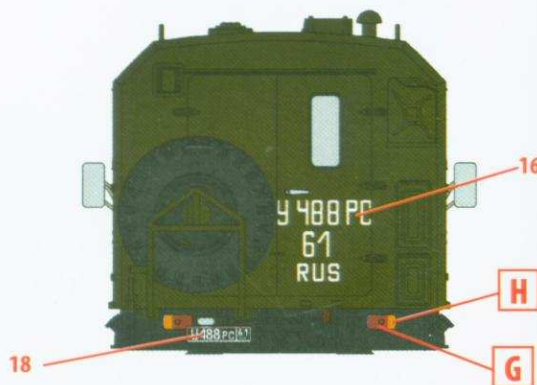

Зил-131 КШМ, армия Украины, конец 2000-х годов
ZiL-131 KShM, Ukrainian Army, late 2000s

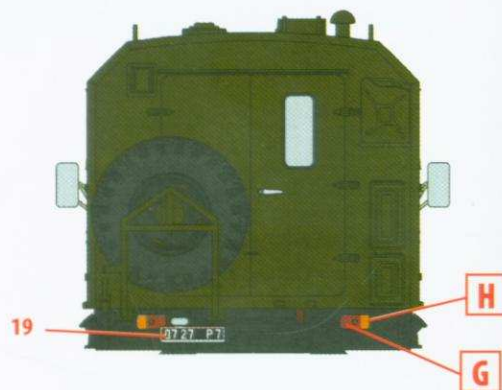

Гвардейская часть
Guard's unit



Группа советских войск в Германии
Group of Soviet Troops in Germany



Народная армия ГДР
GDR People's Army

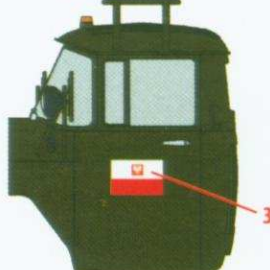

Армия Польши
Polish Army



Армия России
Russian Army



Армия Украины
Ukrainian Army